

for DMIC files

74301

NASA TECHNICAL NOTE

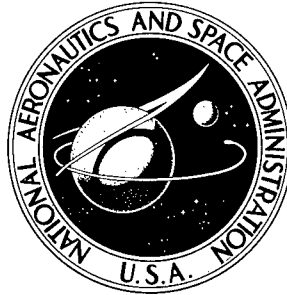

NASA TN D-5157

NASA TN D-5157

AMPTIAC

EXPLORATORY STUDY OF SILICIDE, ALUMINIDE, AND BORIDE COATINGS FOR NITRIDATION-OXIDATION PROTECTION OF CHROMIUM ALLOYS

by Joseph R. Stephens and William D. Klopp

Lewis Research Center

Cleveland, Ohio

20000711 151

NATIONAL AERONAUTICS AND SPACE ADMINISTRATION • WASHINGTON, D. C. • APRIL 1969

DISTRIBUTION STATEMENT A

Approved for Public Release
Distribution Unlimited

**Reproduced From
Best Available Copy**

FORM 1-64 (REV. 1-64) 4

NASA TN D-5157

EXPLORATORY STUDY OF SILICIDE, ALUMINIDE, AND BORIDE COATINGS
FOR NITRIDATION-OXIDATION PROTECTION OF CHROMIUM ALLOYS

By Joseph R. Stephens and William D. Klopp

Lewis Research Center
Cleveland, Ohio

NATIONAL AERONAUTICS AND SPACE ADMINISTRATION

For sale by the Clearinghouse for Federal Scientific and Technical Information
Springfield, Virginia 22151 - CFSTI-

ABSTRACT

Chromium alloys were coated with silicon, aluminum, and boron by pack cementation. None of these simple coatings provided adequate nitridation-oxidation protection for a chromium +0.17 wt % yttrium alloy substrate as shown by a substantial increase in the ductile-brittle transition temperature after air exposure for 100 hr at 2100° F (1420 K). Iron modified silicide coatings afforded good protection, holding the transition temperature of air exposed specimens to 350° F (450 K) compared to 200° F (370 K) for recrystallized uncoated specimens. Additional attractive modifying elements included iron-molybdenum, iron-molybdenum-tungsten, iron-molybdenum-tungsten-titanium and vanadium-molybdenum-tungsten-titanium.

EXPLORATORY STUDY OF SILICIDE, ALUMINIDE, AND BORIDE COATINGS FOR NITRIDATION-OXIDATION PROTECTION OF CHROMIUM ALLOYS

by Joseph R. Stephens and William D. Klopp

Lewis Research Center

SUMMARY

A study was conducted to investigate protective coatings for chromium alloys for use in advanced airbreathing engine applications. Pack cementation was used as the primary method of coating application. A standard air-exposure test selected to characterize the coatings consisted of heating in static air at 2100⁰ F (1420 K) for 100 hours. Primary evaluation was determination of the ductile-brittle bend transition temperature for specimens as coated and after air exposure since nitrogen embrittlement is considered to be the key problem area.

Results showed that simple coatings of silicon, aluminum, boron, and titanium applied by pack cementation do not provide adequate protection for the chromium + 0.17 weight percent yttrium alloy. Silicide coatings did not provide a protective coating as was shown by the formation of Cr₂O₃ on the surface. Embrittlement of the substrate by boron was apparently associated with the formation of the hard, brittle CrB₂ phase. The high solubility of aluminum in chromium and resultant embrittlement makes aluminide coatings unattractive for extended life at 2100⁰ to 2400⁰ F (1420 to 1590 K). Titanium coated specimens were embrittled due to interaction of oxygen and nitrogen with the substrate.

An iron modified silicide coating provided good protection for a chromium + 0.17 weight percent yttrium alloy at 2100⁰ F (1420 K). The ductile-brittle transition temperature of coated specimens after 100 hours in air at 2100⁰ F (1420 K) was 350⁰ F (450 K) compared to 200⁰ F (370 K) for recrystallized, uncoated specimens and 800⁰ F (700 K) for uncoated specimens after the same air exposure. The iron modified silicide coating also provided good protection for a more highly alloyed substrate, chromium + 5 weight percent tungsten + 0.18 weight percent yttrium. Several other complex modified silicide coatings appeared attractive, including iron-molybdenum, iron-molybdenum-tungsten, iron-molybdenum-tungsten-titanium, and vanadium-molybdenum-tungsten-titanium.

Results from cyclic air exposure tests showed that uncoated and simple silicide coated specimens after an initial weight gain lost weight due to volatilization of Cr₂O₃ and spalling of the silicide coating. Specimens protected with iron-modified silicide coatings or 15 weight percent vanadium - 35 weight percent molybdenum - 35 weight percent titanium-modified silicide coatings obeyed a cubic relation of weight gain with time.

INTRODUCTION

The desirability of increased operating temperatures as a means of improving the efficiency of advanced air breathing engines has resulted in emphasis on the development of materials with high operating temperature capabilities. Chromium, because of its relatively low density (7.19 g/cm^3), high melting point (3410° F (2150 K)) (ref. 1), and adequate strength upon alloying, is a candidate material for turbine buckets and stator vanes of advanced air breathing engines. However, chromium is not without severe limitations, the major one being susceptibility to nitrogen embrittlement upon exposure to air at high temperatures. For example, a 25-hour air exposure of a Cr + 5 percent W¹ alloy at 2100° F (1420 K) produces a 600° F (330 K) increase in the ductile-brittle transition temperature (ref. 2).

Although dilute alloying with such elements as Y, La, and Th (ref. 3) or nitride formers (ref. 4) has been shown capable of reducing nitrogen embrittlement, it is apparent that some additional form of surface protection, such as coatings or claddings, will be required for long time service in air breathing engines. Studies of aluminide (ref. 5) and silicide (ref. 6) coatings and of nickel-base claddings (ref. 2) on chromium alloys to date have suggested that these protection systems are inadequate. Of the aluminide systems studied (ref. 5), a simple aluminum and an iron-aluminum coating on a Cr + 5W + 0.1 Y alloys showed the lowest air exposure weight gains. However, the air exposures raised the ductile-brittle transition temperature of the coated specimens to above 1600° F (1140 K) from an initial level in unexposed specimens of about 500° F (530 K). A second investigation for protection of Cr + 5W + 0.1 Y using gas pressure bonded alloy foils resulted in air exposure lives based on appearance and weight gains of over 600 hours at 2100° F (1420 K), with an aluminized Ni + 2Cr + 20W alloy plus an unalloyed tungsten barrier layer giving the best performance (ref. 2). However, the bend ductile-brittle transition temperature was increased to at least 1000° F (810 K) after 100 hours at 2100° F (1420 K) in air compared to 500° F (530 K) for unexposed specimens.

Since better coatings for chromium alloys to be used in aircraft engines are still needed, the present program was undertaken to further investigate protective coatings for chromium alloys. A number of potential coating systems were explored. These included: (1) simple coatings of silicon, aluminum, boron, and titanium deposited on chromium alloy bend-test specimens by pack cementation; (2) multielement pack cementation coatings modified to increase nitridation-oxidation resistance; and (3) nickel or cobalt applied by electroplating. The prime criterion of protection system effectiveness was the ductile-brittle transition temperature in the as-coated and high temperature air-exposed conditions.

¹All compositions in weight percent.

EXPERIMENTAL PROCEDURE

Substrate Materials

Two chromium base alloys were used as a substrate for this study. Chromium + 0.17 Y was prepared by arc melting 80 gram buttons, drop casting into a square cross section water cooled copper mold and subsequently fabricating to approximately 0.035 inch (0.89 mm) sheet by rolling. Melting and fabrication procedures have been described previously (ref. 7). A limited number of tests were performed on Cr + 5W + 0.18 Y alloy which was obtained as approximately 0.025 inch (0.63 mm) sheet (ref. 8). This alloy was prepared by induction melting as a 100-pound ingot followed by fabrication by extruding and rolling to sheet. Details of melting and fabricating procedures can be found elsewhere (ref. 8). Chemical analysis of the two substrate alloys are listed in table I.

TABLE I. - CHEMICAL ANALYSES OF
CHROMIUM ALLOY SUBSTRATE

| Alloy, wt. % | W, wt. % | Y, wt. % | C | O | N | H | S | P |
|------------------|----------|----------|-----------------------|----|----|----|----|----|
| | | | Impurity content, ppm | | | | | |
| Cr + 0.17 Y | ---- | 0.17 | 60 | 51 | 6 | 5 | -- | -- |
| Cr + 5W + 0.18 Y | 5.02 | .18 | 12 | 95 | 24 | 12 | 20 | 20 |

Specimen Preparation

Bend test specimens measuring 0.25 inch (6.3 mm) by 0.75 inch (19 mm) or 0.3 inch (8 mm) by 0.9 inch (23 mm) were cut from sheet with the long dimension of the specimen parallel to the rolling direction. After cleaning in hydrochloric acid to remove surface contamination resulting from fabrication, bend specimens were recrystallized by heating at 2100^o F (1420 K) for 1 hour in high purity argon. The recrystallized specimens were tumbled for 120 hours in a ball mill containing 180 grit silicon carbide to produce rounded edges and corners for better coating application in these areas. The specimens were cleaned in hydrochloric acid, rinsed in water, and then in acetone prior to coating.

Coating Procedure

Pack cementation was used as the primary coating process to apply simple coatings

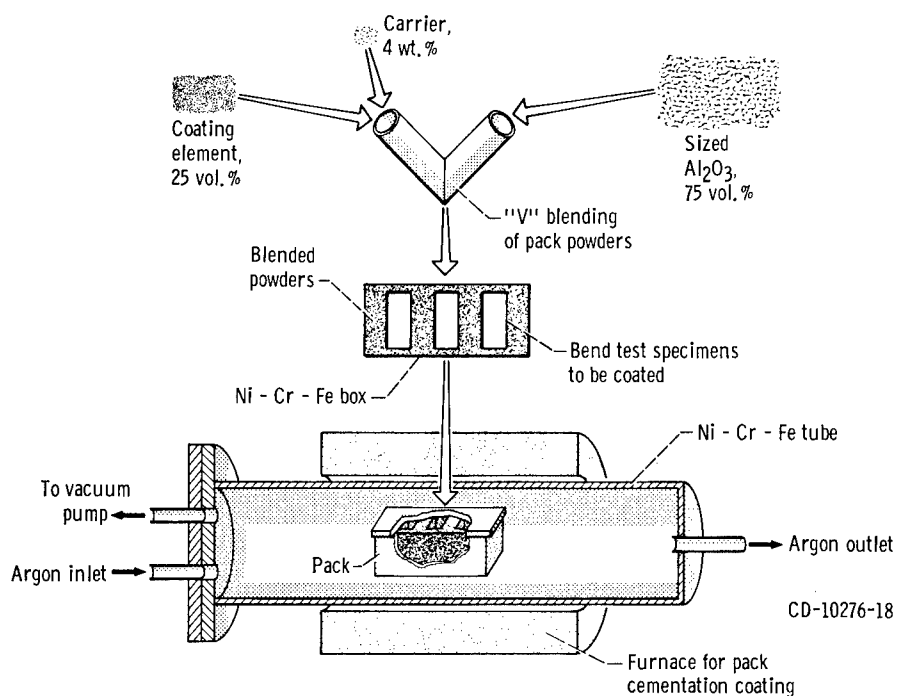

Figure 1. - Schematic of major steps involved in pack cementation process.

of silicon, aluminum, boron, and titanium. Figure 1 shows schematically the steps involved in the pack cementation process. The relative thermodynamic stabilities of the carrier, the coating-element halides, and the chromium halides were used as guides in selecting carriers for each of the coating-elements. Previous results have indicated (ref. 9) the relative stabilities of the halides to obtain adequate pack coating conditions should be as follows:

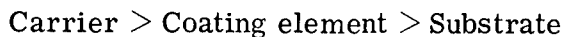

Table II lists the free energy of formation for the various halides of interest in this program. By proper selection of carrier-coating element halide combinations silicon, aluminum, boron, and titanium could be applied by the pack cementation process. However, iron, nickel, cobalt, and molybdenum cannot be applied to chromium by pack cementation. Hence, a Ni-Cr-Fe alloy was selected as the material for the reaction box and tube, as indicated in figure 1.

High purity alumina powder used as filler in the pack was sized to -100 + 140 mesh in order to remove from the powder the "fines," which could block passages to the chromium specimen and prevent uniform access of the coating element halide to the specimens. After loading the pack box, the tube was evacuated to approximately 20 micrometers and subsequently filled with high purity argon. Coating was performed under

TABLE II. - FREE ENERGY OF FORMATION OF INDICATED
 HALIDES (REFS. 10 AND 11)

[kcal/g-atom halide; T = 1880° F (1300 K).]

| Halide | Carrier | | | | | Coating Element | | | | | | | | | Substrate |
|--------|---------|-----|----|-----|-----|-----------------|----|----|----|----|----|----|----|----|-----------|
| | Ba | Ca | K | Na | Li | Al | Si | Ti | B | Fe | Ni | Co | Mo | Cr | |
| F | 116 | 118 | 98 | 103 | 115 | 83 | 82 | 79 | 85 | 63 | 55 | 58 | 50 | 69 | |
| Cl | 78 | 74 | 69 | 68 | 74 | 43 | 26 | 37 | 27 | 24 | 15 | 20 | 5 | 28 | |
| Br | 68 | 63 | 33 | 65 | 33 | 33 | -- | -- | 13 | 16 | 9 | 11 | 1 | 20 | |
| I | 55 | 48 | 29 | 50 | 31 | 25 | -- | 18 | -- | 4 | 0 | 0 | -- | 10 | |

flowing argon in two cycles to insure adequate coverage over the entire surface of the specimens. Specimens were removed from the pack and weighed prior to repacking in a new mix for the second cycle.

Since nickel and cobalt could not be applied by the pack cementation process, electroplating was chosen as the method to deposit these elements on chromium. A Watt's Bath technique was used for electroplating Ni and a sulfate bath for Co electroplating (ref. 12).

Modified silicide coatings were investigated in order to improve the protection afforded by the simple silicide coatings. Modifying elements in powder form were mixed with cellulose nitrate to form a slurry which was painted on the test specimens, a technique used previously for Ta alloys (ref. 13). After drying in air the specimens were slowly heated in vacuum to 1000° F (810 K) and held for 10 minutes to drive off the cellulose nitrate and then heated to 1700° F (1200 K) and held for 3 hours to sinter the modifying powder. Siliciding was then accomplished by pack cementation. A glass frit was applied subsequent to siliciding on several simple and modified silicide coatings. This was accomplished by a technique previously described (ref. 13) which consists of dipping coated specimens in a slurry of glass frit in water, allowing to air dry, and then brushing off the excess glass prior to air exposure.

A coating of SiB₆ was applied by brushing on a slurry of SiB₆ + polyisobutylene (viscosity of 10 000 cP) + toluene followed by heating in air at 800° F (700 K) for 30 minutes to drive off the binder and then heated at 1900° F (1310 K) for 2 hours to form a vitreous coating.

Air Exposure Tests

A static air exposure test of 100 hours at 2100° F (1420 K) was selected for this

exploratory investigation based on the proposed use of chromium alloys at temperatures of 2000^o to 2400^o F (1370 to 1590 K) for air breathing engine applications. Temperature was held within $\pm 10^{\circ}$ F (± 5 K) of the control temperature. Tests were conducted in a horizontal alumina tube furnace using alumina supports for the specimens.

Bend Tests

Bend tests were conducted at a crosshead speed of 1 inch (25 mm) per minute over a bend radius approximately four times the specimen thickness (4 T). Steel rollers were used for the plunger and support pins. Tests were conducted in air in a quartz tube radiation furnace. Temperature was measured by a thermocouple in contact with the loading fixture adjacent to the test specimen. The ductile-brittle bend transition temperature (DBTT) is defined as the lowest temperature at which a specimen could be bent 100^o, the limit of the bend fixture.

Hardness and Metallographic Examination

Hardness profiles from the outer surface of the coating to the center of the specimen were determined for specimens in the as-coated and air-exposed conditions. A microhardness tester (50 gram load) with a Knoop indenter was used for all hardness tests.

Specimens were examined metallographically to determine the extent of coating-substrate reaction during coating and air exposure and the extent of nitride formation after air exposure.

X-ray Diffraction and Electron Microprobe Examination

Selected specimens were examined by X-ray diffraction and by electron microprobe to identify compounds and to determine element concentrations in the coating before and after air exposure.

RESULTS AND DISCUSSION

Simple Coatings

Coating process. - Table III summarizes typical coating conditions and thicknesses

TABLE III. - COATING CONDITIONS AND THICKNESSES FOR SIMPLE
COATINGS ON CHROMIUM + 0.17 YTTRIUM ALLOY SUBSTRATE

| Coating element | Carrier | Reaction temperature | | Reaction time, hr | Calculated coating thickness ^a | | Compound assumed |
|-----------------|---------|----------------------|------|-------------------|---|----------------------|---------------------------------|
| | | °F | K | | in. | mm | |
| Si | LiF | 1950 | 1340 | 2 | 1.9×10^{-3} | 4.8×10^{-2} | CrSi ₂ |
| | LiF | 1950 | 1340 | 6 | 2.0 | 5.1 | CrSi ₂ |
| Al | NaI | 1900 | 1310 | 2 | 1.8×10^{-3} | 4.6×10^{-2} | Cr ₅ Al ₈ |
| | NaI | 1900 | 1310 | 6 | 1.9 | 4.8 | Cr ₅ Al ₈ |
| B | LiF | 1900 | 1310 | 2 | 0.5×10^{-3} | 1.0×10^{-2} | CrB ₂ |
| | LiF | 2100 | 1420 | 6 | .7 | 2.0 | CrB ₂ |
| Ti | NaCl | 1900 | 1310 | 3 | 0.3×10^{-3} | 1.0×10^{-2} | Cr ₂ Ti |
| | NaCl | 2000 | 1370 | 3 | .6 | 2.0 | Cr ₂ Ti |

^aComputed from weight gain.

for silicon, aluminum, boron, and titanium applied by pack cementation. Based on the weight gain data for the silicide and aluminide coatings, coating thicknesses after 2 hours and 6 hours were calculated assuming that CrSi₂ and Cr₅Al₈ were formed. The calculated thicknesses indicated that the growth rate of the silicide and aluminide coatings were approximately parabolic and hence controlled by interdiffusion of substrate and coating element. The growth rates of the boron and titanium coatings were not established as clearly as for the preceding coatings; however, by proper choice of the carrier halide, coatings of boron and titanium were successfully applied.

Ductile-brittle transition temperature. - The effects of the four simple coatings applied by pack cementation and of a nickel coating applied by electroplating on the DBTT of Cr + 0.17 Y are shown in figure 2. The nickel coating produced a 50° F (18 K) decrease in DBTT of the chromium alloy substrate. This effect may be analogous to tungsten clad with copper where it has been observed that copper cladding produces a reduction in the DBTT of tungsten (ref. 14). All of the coatings applied by pack cementation produced an increase in the DBTT of the chromium substrates. The silicide coating was the least detrimental, increasing the DBTT only to 225° F (380 K) compared to 200° F (370 K) for the uncoated substrate in the recrystallized condition.

Air exposure at 2100° F (1420 K) for 100 hours produced a substantial increase in DBTT of both the uncoated and coated chromium alloy specimens as shown in figure 3. After this exposure, the uncoated specimen had a DBTT of 800° F (700 K). The aluminide coated specimens had the lowest DBTT, about 500° F (530 K) compared to 400° F (480 K)

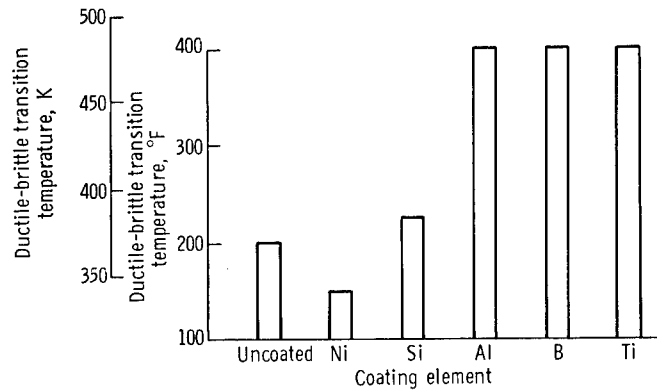

Figure 2. - Effects of simple coatings on ductile-brittle transition temperature of Cr + 0.17Y in the as-coated condition.

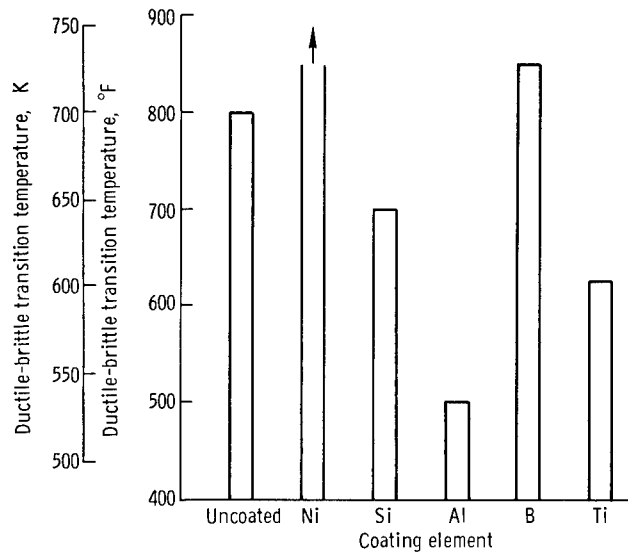

Figure 3. - Effects of air exposure for 100 hours at 2100° F (1420 K) on ductile-brittle transition temperature of uncoated and simple coated Cr + 0.17Y.

for specimens in the as-coated condition. Titanium and silicide coatings also were moderately effective in protecting the substrate as indicated by their DBTT's of 625° F (600 K) and 700° F (640 K), respectively. The nickel plated and boron coated specimens were not resistant to embrittlement their DBTT's being higher than those of uncoated and exposed specimens.

Silicide coated and aluminide coated specimens were also exposed in air at 2400° F (1590 K) for 100 hours. At this temperature silicide coated specimens exhibited somewhat less embrittlement than aluminide coated specimens. The DBTT for silicide coated specimens after the exposure was 850° F (730 K) compared to 900° F (755 K) for the aluminide coated specimens.

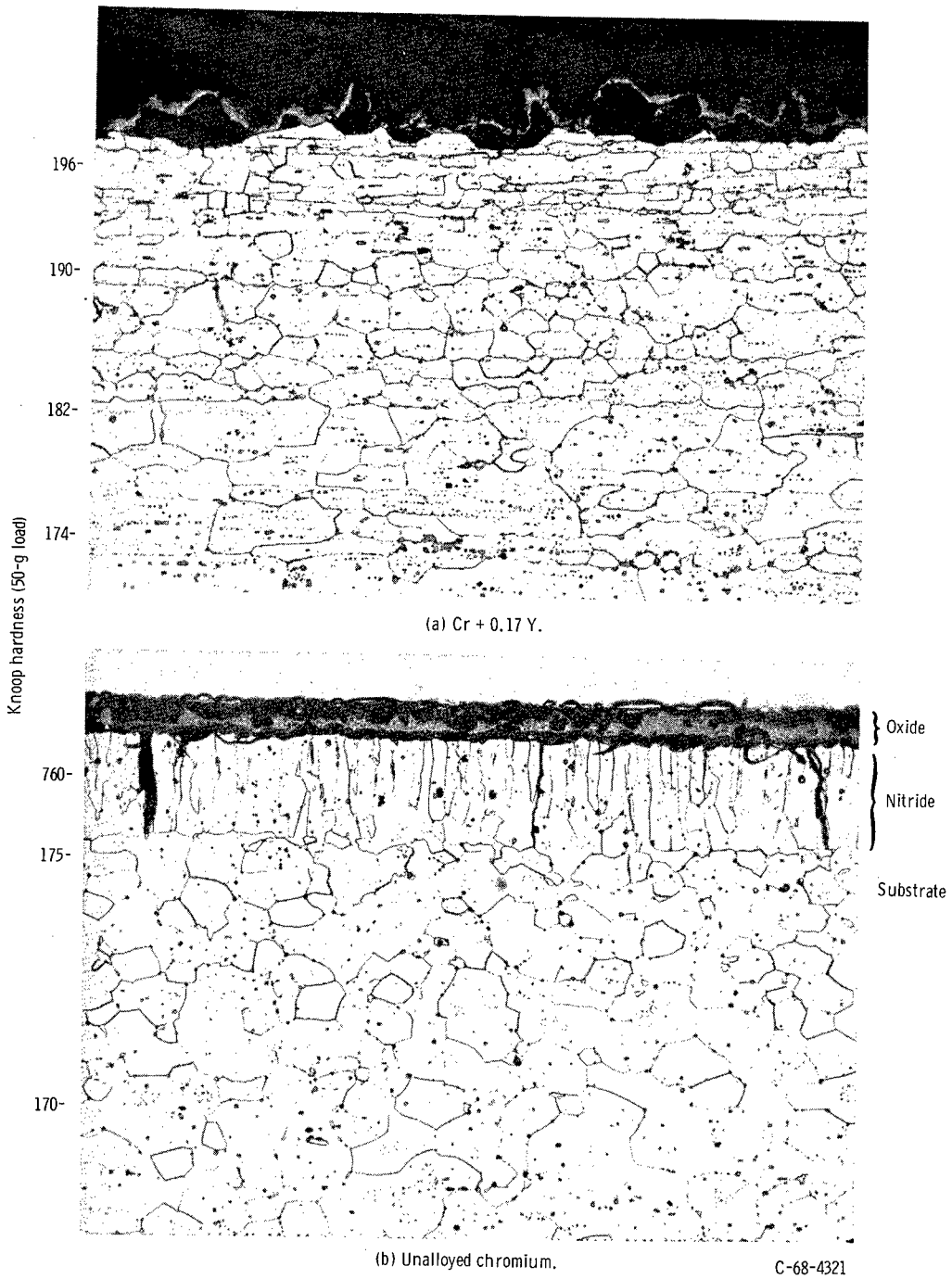

Figure 4. - Microstructure and hardness of uncoated Cr + 0.17 Y and unalloyed chromium after 100 hours at 2100° F (1420° K) air exposure. 250X.

Complementary evaluation. - Metallographic examination of the uncoated Cr + 0.17 Y alloy after 2100^o F (1420 K) air exposure, figure 4(a) revealed the absence of nitride formation. In contrast, unalloyed Cr forms columnar grains of Cr₂N near the surface after a similar treatment as shown in figure 4(b). The microstructures illustrate the beneficial effect of the dilute addition of Y to Cr. Table IV lists the results of visual

TABLE IV. - COATING DATA AND AIR EXPOSURE DATA FOR UNCOATED AND COATED SPECIMENS

| Coating type | Weight ratio of modifying element to coating element | Weight gain ^a during air exposure, mg/cm ² | As coated | | Air exposed | | Surface appearance and X-ray diffraction results after air exposure |
|-----------------------------|--|--|--|------|----------------|------|---|
| | | | Ductile-brittle transition temperature | | | | |
| | | | ^o F | K | ^o F | K | |
| Uncoated | | | | | | | |
| Substrate Cr + 0.17 Y | ---- | 2.0 | ^b 200 | 370 | 800 | 700 | Green Cr ₂ O ₃ |
| Substrate Cr + 5W + 0.18 Y | ---- | 1.6 | ^b 450 | 510 | >1280 | >970 | Gray-green oxide |
| Simple coatings | | | | | | | |
| Silicide | ---- | 0.5 | 225 | 380 | 700 | 640 | Coating spalled, green Cr ₂ O ₃ |
| Aluminide | ---- | 3.0 | 400 | 480 | 500 | 530 | Gray Al ₂ O ₃ |
| Boride | ---- | 2.5 | 400 | 480 | 850 | 730 | Green Cr ₂ O ₃ |
| Ti | ---- | -2.0 | 400 | 480 | 625 | 600 | Green Cr ₂ O ₃ |
| Ni | ---- | .5 | 150 | 340 | >850 | >730 | Coating spalled, green Cr ₂ O ₃ |
| Modified aluminide coatings | | | | | | | |
| Ni modified | 2.0 | 2.1 | 425 | 490 | 550 | 560 | Gray Al ₂ O ₃ |
| Co modified | 1.0 | 1.5 | 400 | 480 | 750 | 670 | Gray Al ₂ O ₃ |
| Modified silicide coatings | | | | | | | |
| B modified | 0.08 | -48.0 | 225 | 380 | 550 | 560 | Coating spalled, green Cr ₂ O ₃ |
| Y modified | 2.2 | 1.9 | 225 | 380 | 500 | 530 | Green Cr ₂ O ₃ |
| Ti modified | 1.5 | 21.0 | 225 | 380 | 450 | 510 | Green Cr ₂ O ₃ |
| Re modified | .5 | 18.0 | >250 | >390 | >400 | >480 | Green Cr ₂ O ₃ |
| Fe modified | .4 | 6.0 | 275 | 410 | 350 | 450 | Brown oxide |
| Ru modified | 1.2 | -31.0 | >250 | >340 | >400 | >480 | Coatings spalled, green oxide |
| Co modified | 2.2 | 10.5 | >250 | >390 | >400 | >480 | Blue-green Cr ₂ O ₃ |
| Rh modified | 2.9 | 7.0 | >250 | >390 | >400 | >480 | Green Cr ₂ O ₃ |
| Ir modified | 1.1 | 1.8 | 300 | 420 | 400 | 480 | Green Cr ₂ O ₃ |
| Ni modified | .01 | 3.9 | 300 | 420 | 450 | 510 | Dark green, vitreous oxide |
| 75 Fe-25 Mo modified | .3 | 4.5 | ---- | ---- | 350 | 450 | Brown oxide |
| 50 Fe-50 Mo modified | .03 | 1.9 | ---- | ---- | 350 | 450 | Green-blue oxide |
| 25 Fe-75 Mo modified | .06 | 1.4 | ---- | ---- | 350 | 450 | Green Cr ₂ O ₃ |
| 50 Fe-50 Ti modified | .56 | -4.1 | ---- | ---- | 400 | 480 | Yellow-blue oxide |
| 35 Fe-30 W | | | | | | | |
| 35 Ti modified | .67 | 9.0 | ---- | ---- | 450 | 510 | Brown oxide |
| 35 Fe-30 Mo | | | | | | | |
| 35 Ti modified | .63 | 39.6 | ---- | ---- | 475 | 520 | Brown-yellow oxide |
| 50 Fe-25 Mo | | | | | | | |
| 25 W modified | .09 | 2.2 | ---- | ---- | 350 | 450 | Blue-green oxide |
| 15 Fe-35 W | | | | | | | |
| 35 Mo, 15 Ti modified | .18 | 6.8 | ---- | ---- | 350 | 450 | Green-blue oxide |
| 15 V-35W | | | | | | | |
| 35 Mo, 15 Ti modified | .15 | 5.4 | ---- | ---- | 350 | 450 | Gray oxide |
| Fe modified ^c | .6 | 4.3 | 550 | 560 | 700 | 640 | Brown oxide |

^aAn air exposure test of 100 hours at 2100^o F (1420 K) in static air was used.

^bUncoated specimens were tested in the recrystallized condition, 1 hour at 2100^o F (1420 K) in argon.

^cCr + 5 W + 0.18 Y substrate.

examination and X-ray diffraction of selected specimens. Results showed the green oxide on air exposed Cr + 0.17 Y alloy specimens to be Cr_2O_3 . Weight gain data are also listed in table IV. However, because of spalling of coatings and volatilization of oxides weight gain data are of limited value in determining coating effectiveness.

Figure 5(a) shows the microstructure of a silicide coated specimen after air exposure at 2100°F (1420K). The thin outer layer was identified by X-ray diffraction (table IV) as Cr_2O_3 . The columnar structure was identified as CrSi_2 and the inner layer is a subsilicide, assumed to be Cr_5Si_3 . The hardnesses of the substrate and coating for this specimen are also shown in figure 5(a). They indicate that the substrate adjacent to the coating was not hardened as a result of air exposure. However, the subsilicide layer was very hard and may act as a crack initiation site and thus produce the high DBTT of silicide coated specimens after air exposure.

The time required for conversion of the disilicide into a lower silicide is a partial indication of the coating protectiveness since it is generally assumed that the lower silicides are less oxidation resistant. From the thickness of the subsilicide shown in figure 5(a) and assuming it to be Cr_5Si_3 , the time required for a 4 mil (0.01 cm) coating of CrSi_2 to convert to Cr_5Si_3 can be calculated using the following equation (ref. 15):

$$K^1 = -\frac{3}{2} \left[\left(\frac{M}{\rho} \right)_{\text{CrSi}_2} \left(\frac{\rho}{M} \right)_{\text{Cr}_5\text{Si}_3} \right] K$$

K^1 disilicide depletion rate, cm^2/sec

M molecular weight

ρ density, g/cm^3 ($4.91\text{ g}/\text{cm}^3$ for CrSi_2 and $5.9\text{ g}/\text{cm}^3$ for Cr_5Si_3 (ref. 16))

K Cr_5Si_3 growth rate, cm^2/sec

The thickness of the subsilicide in figure 5(a) is 0.7 mil (0.0018 cm) after 100 hours at 2100°F (1420K). Therefore, for complete conversion of a 4 mil (0.01 cm) coating of CrSi_2 to Cr_5Si_3 , approximately 5400 hours at 2100°F (1420K) would be required.

Figure 5(b) is a photomicrograph of a silicide coated specimen after air exposure at 2400°F (1590K) for 100 hours. Nitride needles have formed in the substrate near the coating. In addition the hardness has increased substantially in this area. Based on the thickness of the subsilicide it was calculated that approximately 900 hours would be required at 2400°F (1590K) to convert the CrSi_2 coating to a lower silicide. The stability of the CrSi_2 is encouraging for potential use at 2400°F (1590K) for times up to several hundred hours. However, the observed formation of nitride needles after only 100 hours suggests that CrSi_2 is not protective against nitrogen penetration.

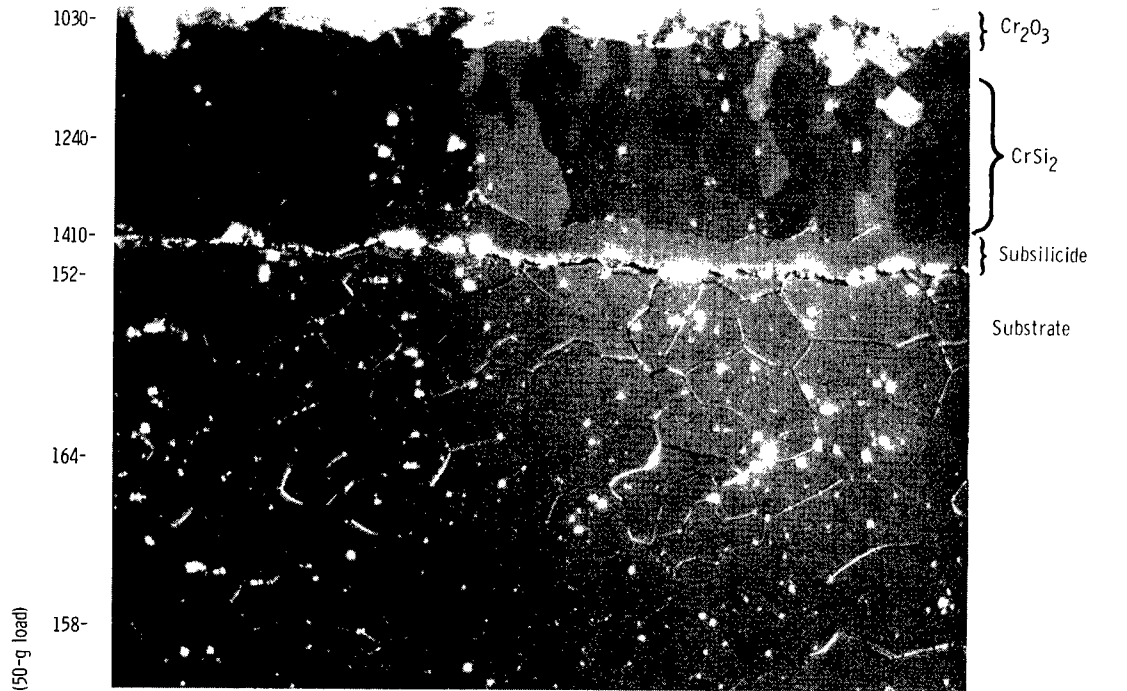

(a) Temperature, 2100° F (1420° K). Polarized light reveals columnar structure of CrSi₂.



(b) Temperature, 2400° F (1590° K).

C-68-4322

Figure 5. - Simple silicide coating on Cr + 0.17 Y substrate after air exposure for 100 hours at 2100° F (1420° K) and 2400° F (1590° K). 250X.

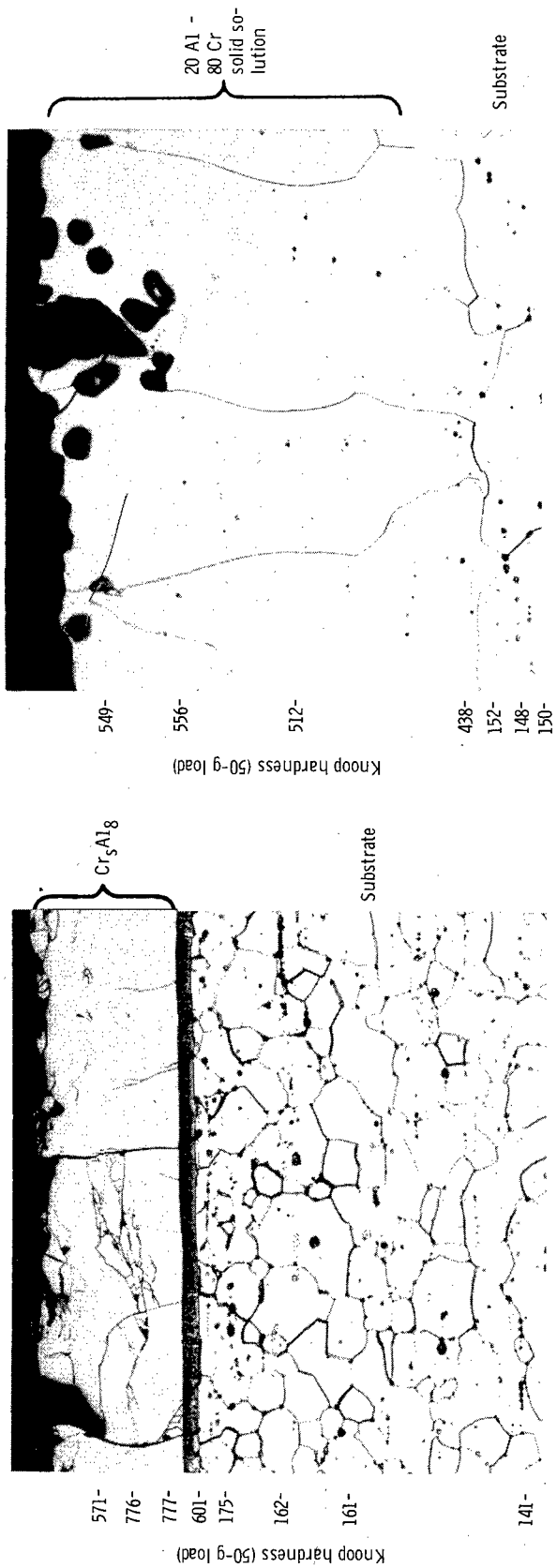

(b) Air exposed, 100 hours at 2100° F (11420° K).

(a) As coated.



C-68-4323

Figure 6. - Simple aluminide coating on Cr + 0.17 Y substrate showing diffusion of coating into substrate during air exposure. 250X.

Aluminide coated specimens are shown in figure 6. X-ray diffraction results of an as-coated specimen indicated that the coating contains approximately 33 atomic percent chromium, close to Cr_5Al_8 (38 at. % chromium). As shown by the hardness measurements, this coating has a lower hardness than the silicide coatings. In addition, very little hardening of the substrate under the coating occurred after air exposure, figures 6(b) and (c). X-ray diffraction results, table IV, confirmed that Al_2O_3 had formed on the surface. This was confirmed by electron microprobe results which also showed that a 20Al-80Cr solid solution had formed at the expense of the Cr_5Al_8 compound. The biggest disadvantage of an aluminide coating on chromium is the rapid growth of the coating into the substrate and the resulting embrittlement. After 100 hours at 2400°F (1590 K) Al had diffused to almost the center of the specimen, figure 6(c), raising the DBTT to greater than 900°F (760 K).

Boride coated chromium is shown in figure 7 after a 2100°F (1420 K) air exposure. Slight hardening of the substrate apparently has occurred, although no nitrides were observed. The hardness of the coating (identified as CrB_2 by X-ray diffraction) is extremely high and may contribute to embrittlement of the substrate in as-coated and high temperature air-exposed specimens.

Air exposure tests at 2100°F (1420 K) of titanium coated specimens led to volatilization of the coating and hardening of the substrate apparently due to nitrogen.

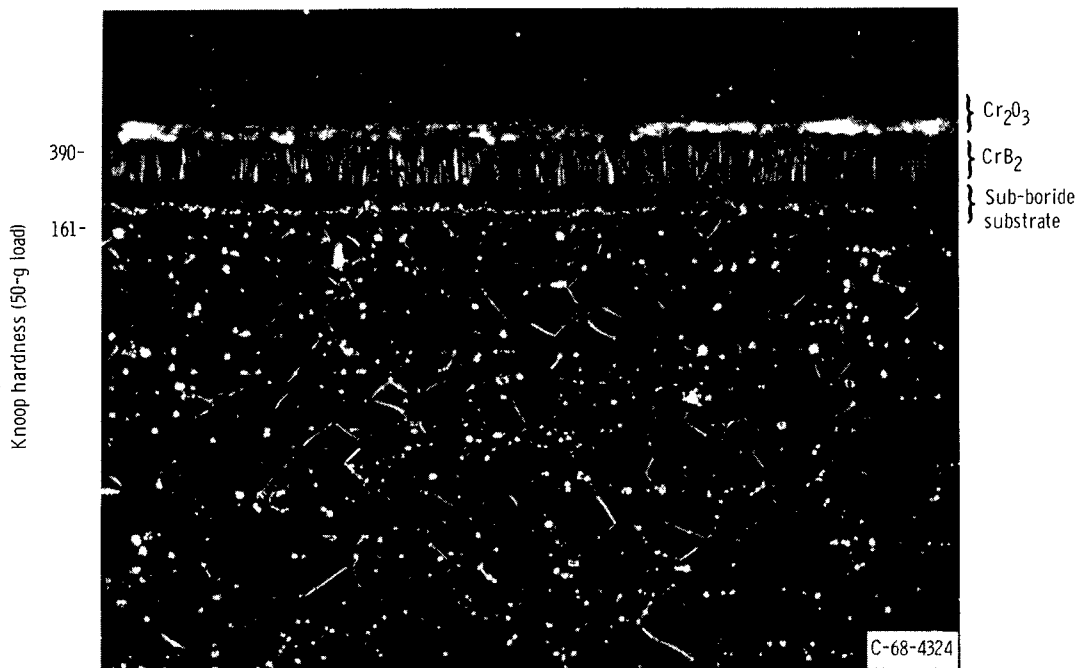

Figure 7. - Simple boride coating on Cr + 0.17 Y substrate after air exposure for 100 hours at 2100°F (1420° K). Polarized light reveals columnar structure of CrB_2 . 250X.

Based on the ductile-brittle transition temperature results, hardness measurements and metallography, it is concluded that embrittlement during air exposure tests occurs primarily because of lack of protection by the silicide and titanium coatings and because of coating-substrate interaction for the aluminide and boride coatings.

Modified Aluminide Coatings

Nickel and cobalt were used as modifying elements for aluminide coatings. Table IV lists weight ratios of modifying elements to coating elements. Electroplating was used to apply a 1 mil (0.003 cm) layer of Ni or Co on specimens which were subsequently aluminided by pack cementation. Figure 8 shows bend test results for both simple and modi-

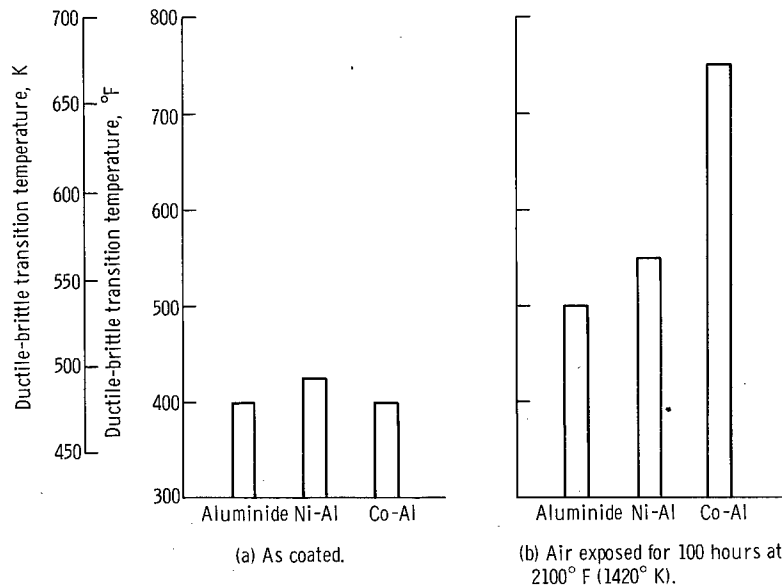

Figure 8. - Effects of coating modifying elements on ductile-brittle transition temperature of silicide-coated Cr + 0.17 y.

fied aluminide coated specimens as-coated and after air exposure for 100 hours at 2100° F (1420 K). It is apparent from these results that the modifying elements chosen were not beneficial in terms of lowering the DBTT of the chromium alloy substrate after air exposure. Metallographic examination of the modified aluminide coatings revealed considerable growth of the coating into the substrate, similar to observations on the simple aluminide coating. In addition, interaction of the substrate with Ni and Co was apparent. Based on these results aluminide coatings are not considered attractive for chromium.

Modified Silicide Coatings

Ductile-brittle transition temperature. - In order to modify the silicide coating, elements from Groups IIIa and IVa of the periodic table were applied to the chromium alloy substrate as a slurry followed by sintering and subsequent siliciding. Modifying elements included B, Y, and Ti. In addition SiB_6 was applied as a slurry.

Bend test results are shown in figure 9 for the modified silicide coatings. Except for the SiB_6 coating, the modified coatings had DBTT's comparable to the simple silicide coating in the as-coated condition and lower DBTT's after air exposure.

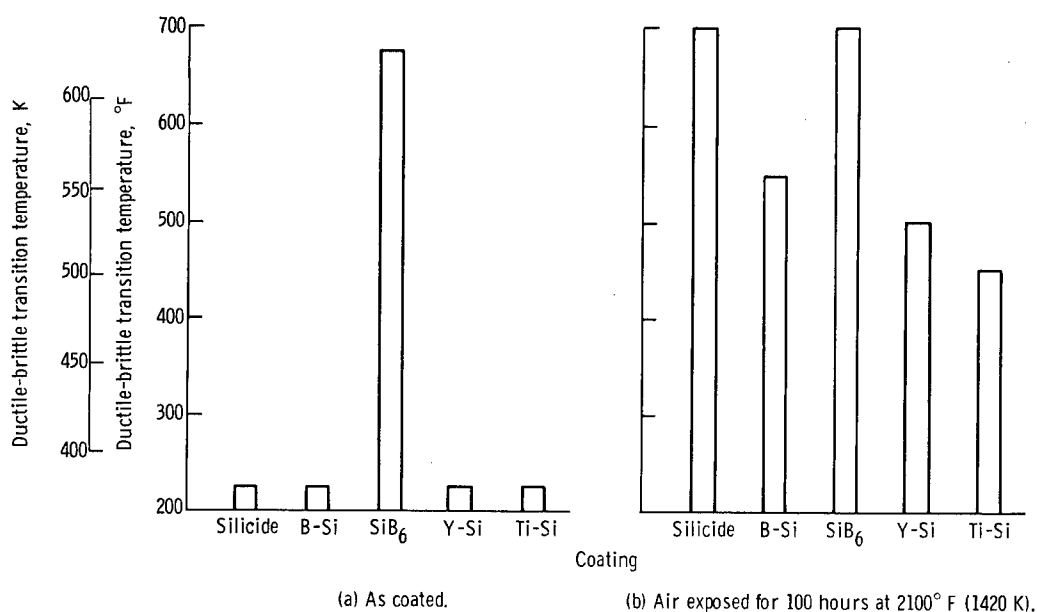

Figure 9. - Effects of Groups III and IV modifying elements on ductile-brittle transition temperature of silicide-coated Cr + 0.17Y.

Effects of modifying elements from Groups VIIa and VIIIa of the periodic table applied by a slurry technique and then silicided are shown in figure 10(a) and (b). At this point in the investigation, a screening test was employed to identify promising modified silicide coatings. The screening test consisted of bend testing as-coated specimens at 250°F (390 K) and air-exposed specimens at 400°F (480 K). If no ductility was observed under either of these test conditions, no further studies were made on the coating in question. However, if bending was noted in either of the two tests the DBTT was then determined for that coating in the as-coated and air-exposed conditions. Figure 10(a) shows that Re, iridium, and Ni modified coatings had DBTT's less than 100°F (55 K) above that of the simple silicide coating in the as-coated condition. After air exposure (fig. 10(b)),

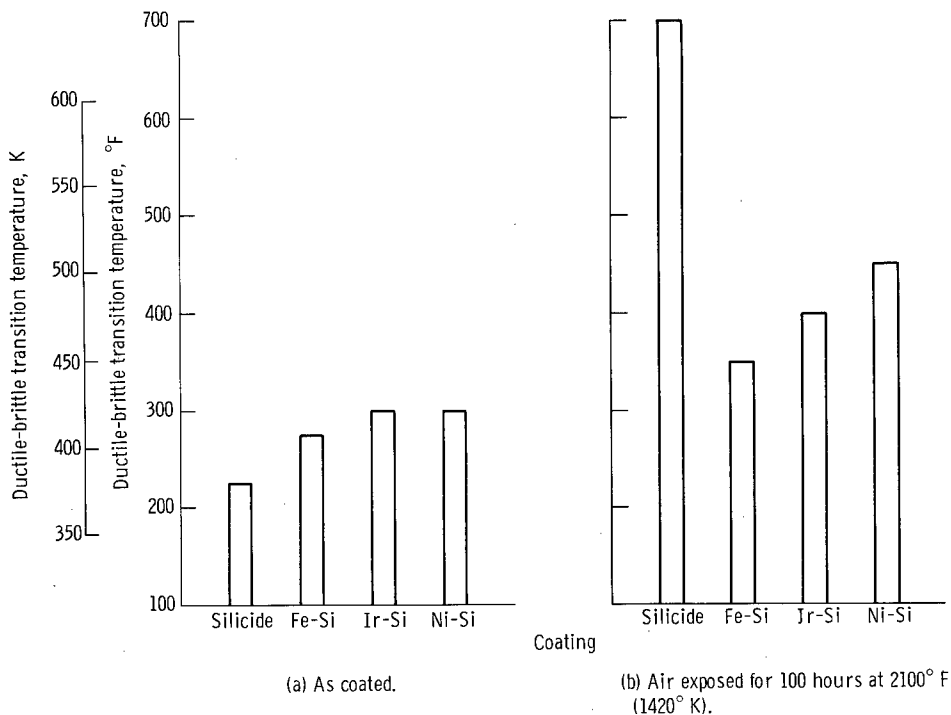

Figure 10. - Effects of Groups VII and VIII modifying elements on ductile-brittle transition temperature of silicate-coated Cr + 0.17Y.

the Fe modified silicide coating had a DBTT of 350°F (450 K) or only 75°F (40 K) above the DBTT for the as-coated condition. Based on the screening bend tests, the modifying elements Re, Ru, Co, and Rh did not prevent embrittlement of the substrate and hence were not investigated further.

Effects of multiple modifying additions to the silicide coating were investigated and results of bend tests for air-exposed specimens are summarized in figure 11. All of these complex modified coatings were superior to the simple silicide coating and six out of the nine coatings had DBTT's comparable to the Fe-modified silicide coating.

Table IV shows that the weight ratio of modifying element to coating element was less than unity for all of these coatings. For the iron modified coating, a silicide of $\text{Cr}_{0.6}\text{Fe}_{0.4}\text{Si}_2$ would be expected upon the Cr + 0.17 Y substrate.

Although the beneficial effects gained from the modified coatings is not completely understood, it is postulated that oxides of the modifying elements lower the melting point of SiO_2 and cause a vitreous, more protective oxide to form on high temperature exposure. The green Cr_2O_3 scale which formed on the simple silicide coated specimens (indicating a nonvitreous scale) was not present on the modified silicide coatings. X-ray diffraction revealed the presence of SiO_2 on the surface of these specimens after air exposure.

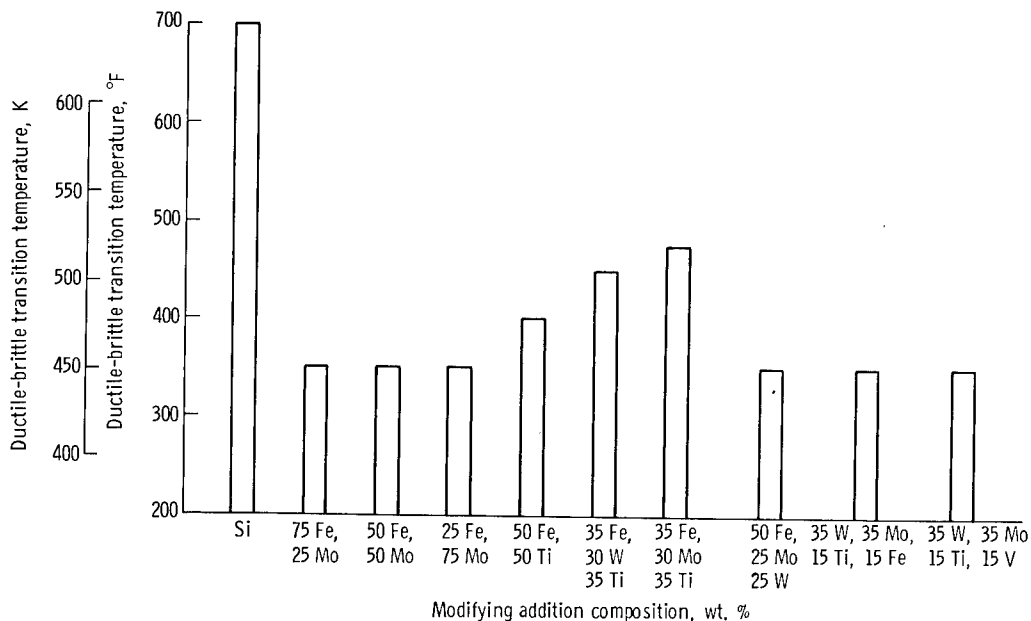
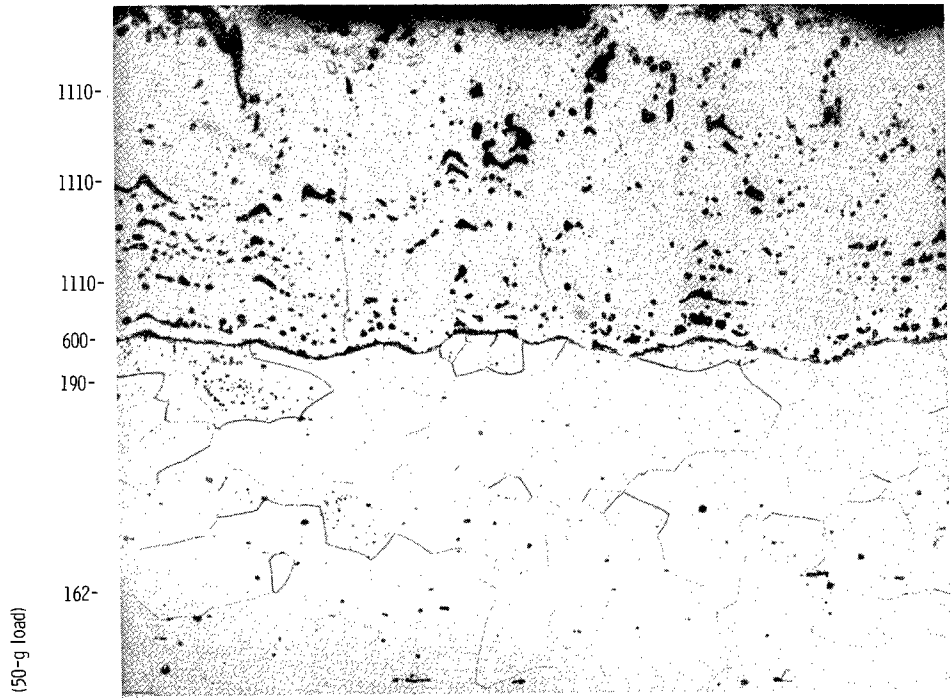

Figure 11. - Effects of multiple modifying additions on ductile-brittle transition temperature of silicided Cr + 0.17Y after air exposure for 100 hours at 2100° F (1420 K).

Metallurgy and hardness. - The Fe-modified silicide coating and the 15V-35Mo-35W-15Ti modified silicide coating were studied in more detail than the other modified coatings. Photomicrographs of air-exposed specimens protected by the two modified coatings are shown in figure 12. Both coatings exhibit growth voids. Slight hardening of the substrate adjacent to the coating also occurred during air exposure. Of particular interest is the narrow width and low hardness of the subsilicide adjacent to the substrate of the Fe modified coating, indicating that Fe may decrease the growth rate of the subsilicide.

Rhenium was investigated as a modifying element because of the low melting point of Re_2O_7 which might lower the vitrification temperature of SiO_2 . Photomicrographs of specimens as-coated and after air exposure are shown in figure 13. Although the coating was applied uniformly as shown in figure 13(a), localized regions of extensive coating-substrate reactions occurred during exposure as shown in figure 13(b). The reason for this localized reaction is not understood; however, it is possible that these areas act as stress concentrators which promote crack initiation and lead to the high DBTT of the air-exposed specimens (fig. 10(b)).

Glass frit. - An attempt to improve the protection afforded by simple and modified silicide coatings was made by applying a layer of glass frit on the surface of silicide coated specimens. Bend tests results showed that the DBTT of simple silicide coated specimens after 2100° F (1420 K) air exposure was reduced from 700° to 500° F (640 to 530 K) as a result of the addition of a glass coating. The DBTT of modified silicide coatings, Fe or W-Mo-Ti-V, was unchanged as a result of an additional coating of glass.



(a) Silicide coating modified with Fe.

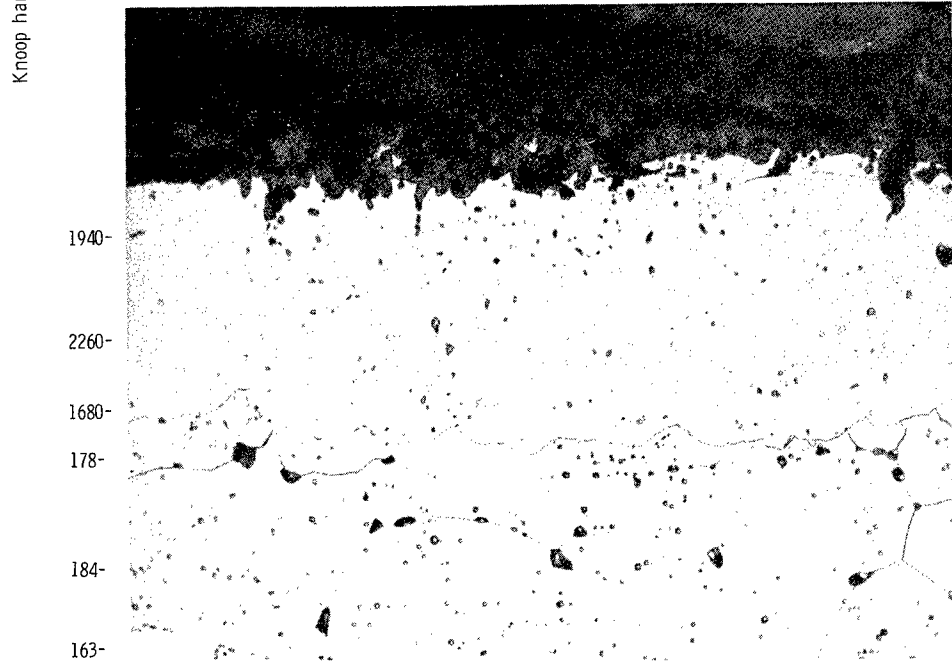

(b) Silicide coating modified with 15V - 35Mo - 35W - 15Ti, C-68-4325

Figure 12. - Microstructures and hardnesses of modified silicide coatings on Cr + 0.17 Y after 100 hours at 2100° F (11420° K), 250X.

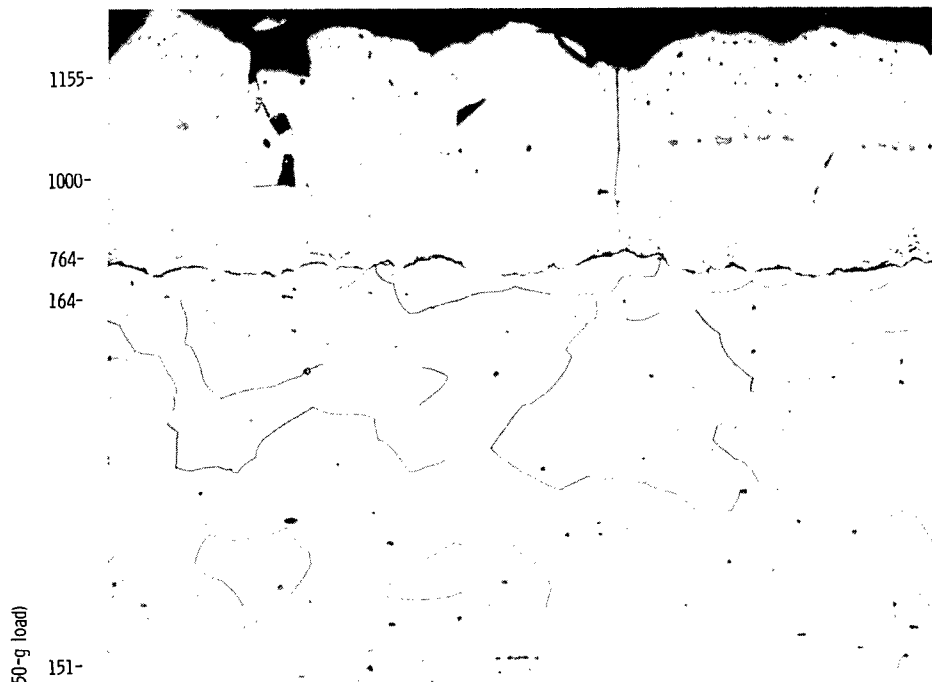

(a) As coated.

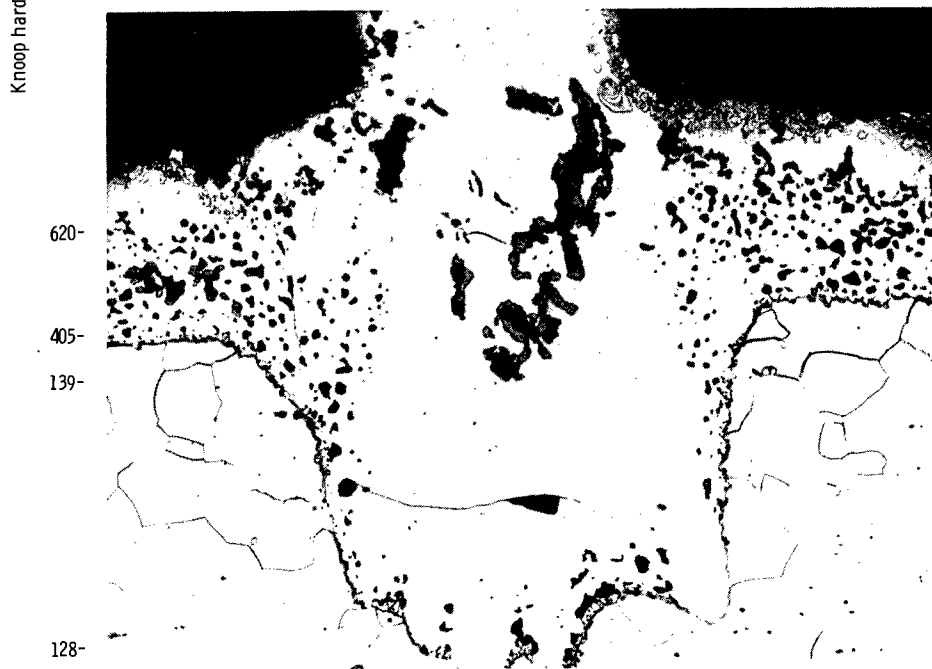

(b) Air exposed for 100 hours at 2100° F (1420° K).

C-68-4326

Figure 13. - Microstructures of Fe-modified silicide coating. 250X.

It is postulated that the beneficial result obtained on simple silicide coated specimens resulted from formation of a vitreous, more protective coating. However, on the modified silicide coatings, the modifying elements served this function and hence the addition of a glass frit gave no further improvement.

Cyclic Air Exposure Tests

Uncoated, silicide coated, Fe-modified silicide coated and 15V-35Mo-35W-15Ti modified silicide coated specimens were heated in static air under cyclic conditions. Table V summarizes weight gain data as a function of total exposure time. Volatilization of the chromium oxide and spalling occurred on the uncoated and simple silicide coated specimens, resulting in the erratic weight gain data shown in figure 14. In contrast, the modified coatings showed a continuous increase in weight with time throughout the entire

TABLE V - WEIGHT GAIN RESULTS FOR CYCLIC AIR EXPOSURE
OF UNCOATED, SILICIDE-COATED, AND MODIFIED-
SILICIDE-COATED CR + 0.17Y

[Air exposure, 100 hr at 2100° F (1420 K).]

| Elapsed time, hr | Uncoated | Silicide | Fe modified | 15V-35Mo-35W-15Ti modified |
|------------------|---------------------------------|----------|-------------|----------------------------|
| | Weight gain, mg/cm ² | | | |
| 0.2 | 0.94 | 0.43 | 1.75 | 1.32 |
| 1 | 1.24 | .14 | 2.19 | 1.31 |
| 2 | 1.38 | .08 | 2.41 | 1.49 |
| 4 | 1.64 | .33 | 2.94 | 2.02 |
| 6 | .94 | .22 | 2.96 | 2.10 |
| 8 | .95 | .46 | 3.23 | 2.50 |
| 10 | .74 | .22 | 3.28 | 2.51 |
| 12 | .90 | .49 | 3.56 | 2.84 |
| 14 | .90 | .50 | 3.69 | 2.92 |
| 16 | .79 | .36 | 3.67 | 2.91 |
| 18 | .81 | .44 | 3.76 | 3.04 |
| 20 | .82 | .48 | 3.85 | 3.11 |
| 40 | 1.03 | .89 | 4.43 | 3.73 |
| 60 | 1.16 | 1.28 | 5.10 | 4.55 |
| 80 | 1.29 | 1.67 | 5.36 | 5.12 |
| 100 | 1.38 | 2.06 | 5.70 | 5.41 |

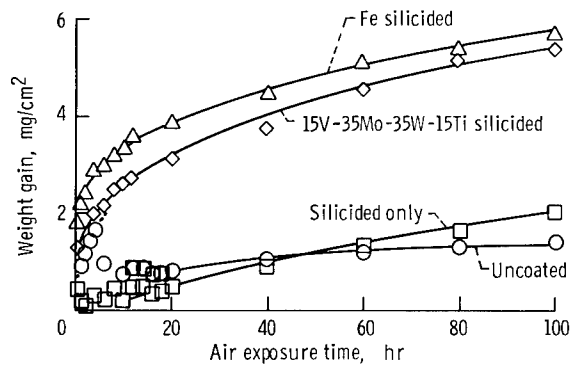

Figure 14. - Weight gains of uncoated, silicide-coated, and modified-silicide-coated Cr + 0.17Y after air exposure for 100 hours at 2100° F (1420 K); cyclic weighing.

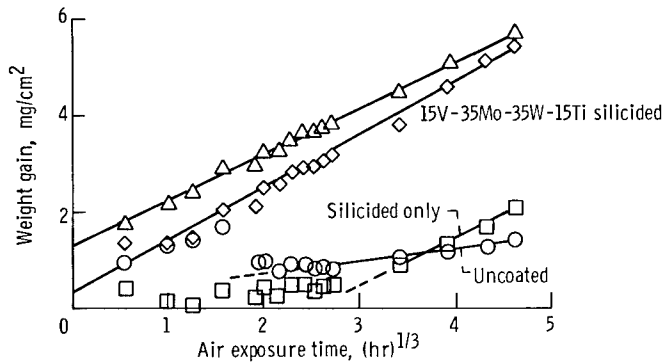

Figure 15. - Weight gain - (time)^{1/3} plots for uncoated, silicide-coated, and modified-silicide-coated Cr + 0.17Y alloy after air exposure for 100 hours at 2100° F (1420 K).

test.] Figure 15 is a replot of the data in figure 14 showing that the weight gain for the Fe-modified and 15V-35Mo-35W-15Ti modified silicide coatings obey a cubic relation with air-exposure time.

Effectiveness of Fe-Modified Silicide Coating on Cr+5W+0.18Y Substrate]

NASA contractors (refs. 2, 5, and 6) investigating protective coatings for chromium have used a Cr+5W+0.18Y alloy as a substrate material. In order to compare the effectiveness of the modified silicide coatings with the protection systems investigated previously (refs. 2 and 5) and also to evaluate the potential use of modified silicide coatings on higher strength chromium alloys, a series of tests were conducted with an Fe-modified silicide coating on the Cr+5W+0.18Y alloy substrate. From table IV, the

include the following

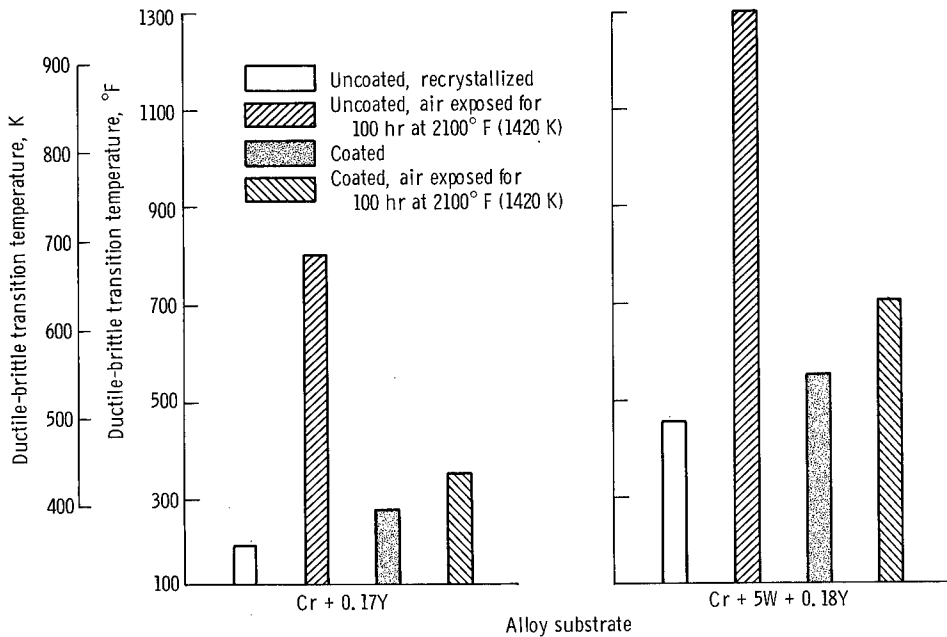
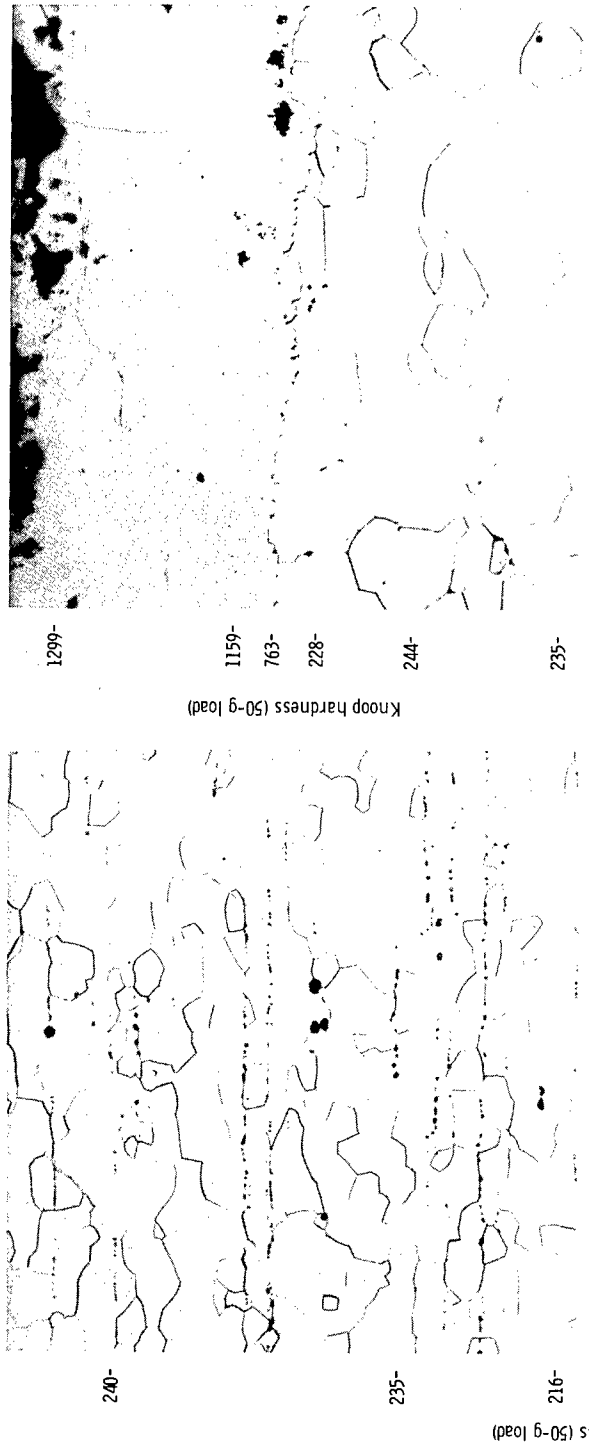

Figure 16. - Effects of Fe-modified silicide coating on ductile-brittle transition temperature of Cr + 0.17Y and Cr + 5W + 0.18Y substrate.

weight ratio of Fe to Si indicates that $\text{Cr}_{0.4}\text{Fe}_{0.6}\text{Si}_2$ was formed during coating. [Figure 16 summarizes bend test results for this series of tests and compares the results with DBTT data for similar tests conducted on a Cr+0.17Y alloy substrate.] The DBTT of the coated, air-exposed Cr+5W+0.18Y specimens is 250° F (140 K) above the DBTT of the recrystallized substrate. This is indicative of substantially better protection (or less embrittlement) than afforded the Cr+5W+0.18Y substrate by previous coatings. By comparison, only a 150° F (80 K) increase in DBTT occurred for the Cr+0.17Y alloy specimens tested under similar conditions. Air exposure of the uncoated Cr+0.17Y alloy specimens resulted in a 600° F (330 K) increase in DBTT while a similar treatment for the uncoated Cr+5W+0.18Y alloy resulted in an increase in DBTT of over 830° F (460 K). Apparently the more complex alloy is more susceptible to embrittlement by nitrogen or oxygen than the binary alloy. Photomicrographs of the Cr+5W+0.18Y specimens from this series of tests are shown in figure 17. Slight hardening of the substrate occurred during air exposure, but no nitride needles were observed.



(a) Cr + 5W + 0.18Y substrate.

(b) As coated.



(c) After air exposure for 100 hours at 2100° F (1420 K). 250X. C-68-4327

Figure 17. - Microstructures and hardness of Cr + 5W + 0.18 Y substrate with an Fe-modified silicide coating. 250X.

CONCLUSIONS

An exploratory study of silicide, aluminide, and boride coatings for chromium alloys led to the following conclusions:

1. An Fe-modified silicide coating affords good nitridation/oxidation protection on Cr+0.17Y and Cr+5W+0.18Y alloy substrates for 100 hours at 2100°F (1420 K).

2. Several more highly alloyed silicide coatings were also effective as nitridation/oxidation barriers on the Cr+0.17Y substrate. The modifiers include Fe-Mo, Fe-Mo-W, Fe-Mo-W-Ti, and V-Mo-W-Ti.

3. A simple silicide coating is not promising as a coating for chromium alloys due to the high ductile-brittle transition temperature, 700°F (640 K) of the coated Cr+0.17Y alloy after air exposure.

4. Aluminide coatings on chromium alloys are not considered desirable due to embrittlement of the substrate resulting from rapid diffusion of the coating into the substrate.

5. Boride coatings are not suitable for chromium alloys because of a hard CrB_2 phase formed during coating and also because of poor nitridation/oxidation resistance.

Lewis Research Center,
National Aeronautics and Space Administration,
Cleveland, Ohio, December 19, 1968,
129-03-06-03-22.

end

REFERENCES

1. Lyman, Taylor, ed.: Properties and Selection of Metals. Vol. 1 of Metals Handbook. 8th ed., ASM, 1961, pp. 44-46.
2. Williams, D. N.; Ernst, R. H.; MacMillan, C. A.; English, J. J.; and Bartlett, E. S.: Development of Protective Coatings for Chromium-Base Alloys. Battelle Memorial Inst. (NASA CR-54619), March 5, 1968.
3. Clark, J. W.: Development of High-Temperature Chromium Alloys. General Electric Co. (NASA CR-92691), June 30, 1967.
4. Henderson, F.; Johnstone, S. T. M.; and Wain, H. L.: The Effect of Nitride-Formers Upon the Ductile-Brittle Transition in Chromium. J. Inst. Metals, vol. 92, 1963-64, pp. 111-117.
5. Negrin, Marvin; and Block, Allan: Protective Coatings for Chromium Alloys. Chromalloy American Corp. (NASA CR-54538), July 13, 1967.

6. Brentnall, W. D.; Shoemaker, H. E.; and Stetson, A. R.: Protective Coatings for Chromium Alloys. Rep. RDR-1398-2, Solar Div., International Harvester (NASA CR-54535), Aug. 20, 1966.
7. Stephens, Joseph R.; and Klopp, William D.: Ductility Mechanisms and Superplasticity in Chromium Alloys. NASA TN D-4346, 1968.
8. Goetz, L. J.; Hughes, J. R.; and Moore, W. F.: The Pilot Production and Evaluation of Chromium Alloy Sheet and Plate. General Electric Co. (NASA CR-72184), Mar. 15, 1967.
9. Klopp, William D.; Powell, Carroll F.; Maykuth, D. J.; and Ogden, Horace R.: Development of Protective Coatings for Tantalum-Base Alloys. Battelle Memorial Inst. (ASD TR 61-676), Jan. 4, 1962.
10. Wicks, C. E.; and Block, F. E.: Thermodynamic Properties of 65 Elements - Their Oxides, Halides, Carbides, and Nitrides. Bulletin 605, Bureau of Mines, Dept. of Interior, 1963.
11. Glassner, Alvin: The Thermochemical Properties of the Oxides, Fluorides, and Chlorides to 2500^o K. Rep. ANL-5750, Argonne National Lab., 1957.
12. Blum, William; and Hogaboom, George B.: Principles of Electroplating and Electroforming. Third ed., McGraw-Hill Book Co., Inc., 1949.
13. Wimber, R. T.; and Stetson, A. R.: Development of Coatings for Tantalum Alloy Nozzle Vanes. Rep. RDR-1396-3, Solar Div., International Harvester Co. (NASA CR-54529), July 1967.
14. Watson, Gordon K.: Effect of Ductile Cladding on the Bend Transition Temperature of Wrought Tungsten. NASA TN D-4184, 1967.
15. Bartlett, R. W.: Investigation of Mechanisms for Oxidation Protection and Failure of Intermetallic Coatings for Refractory Metals. Rep. U-3267, Aeronutronic (ASD-TDR-63-753, pt. III, DDC No. AD-472919), Oct. 14, 1965.
16. Lynch, James F.; Ruderer, Clifford G.; and Duckworth, Winston H.: Engineering Properties of Ceramics, Databook to Guide Materials Selection for Structural Application. Battelle Memorial Inst. (AFML-TR-66-52, DDC No. AD-803765), July 13, 1966.

NATIONAL AERONAUTICS AND SPACE ADMINISTRATION
WASHINGTON, D. C. 20546
OFFICIAL BUSINESS

POSTAGE AND FEES PAID
NATIONAL AERONAUTICS AND
SPACE ADMINISTRATION

FIRST CLASS MAIL

POSTMASTER: If Undeliverable (Section 158
Postal Manual) Do Not Return

"The aeronautical and space activities of the United States shall be conducted so as to contribute . . . to the expansion of human knowledge of phenomena in the atmosphere and space. The Administration shall provide for the widest practicable and appropriate dissemination of information concerning its activities and the results thereof."

— NATIONAL AERONAUTICS AND SPACE ACT OF 1958

NASA SCIENTIFIC AND TECHNICAL PUBLICATIONS

TECHNICAL REPORTS: Scientific and technical information considered important, complete, and a lasting contribution to existing knowledge.

TECHNICAL NOTES: Information less broad in scope but nevertheless of importance as a contribution to existing knowledge.

TECHNICAL MEMORANDUMS: Information receiving limited distribution because of preliminary data, security classification, or other reasons.

CONTRACTOR REPORTS: Scientific and technical information generated under a NASA contract or grant and considered an important contribution to existing knowledge.

TECHNICAL TRANSLATIONS: Information published in a foreign language considered to merit NASA distribution in English.

SPECIAL PUBLICATIONS: Information derived from or of value to NASA activities. Publications include conference proceedings, monographs, data compilations, handbooks, sourcebooks, and special bibliographies.

TECHNOLOGY UTILIZATION PUBLICATIONS: Information on technology used by NASA that may be of particular interest in commercial and other non-aerospace applications. Publications include Tech Briefs, Technology Utilization Reports and Notes, and Technology Surveys.

Details on the availability of these publications may be obtained from:

SCIENTIFIC AND TECHNICAL INFORMATION DIVISION
NATIONAL AERONAUTICS AND SPACE ADMINISTRATION
Washington, D.C. 20546