

**Design Philosophy and
Material Choice for a Tuner
in an Electromagnetic
Reverberation Chamber**

Frank Weeks and
Kevin Goldsmith

DSTO-TN-0257

DISTRIBUTION STATEMENT A
Approved for Public Release
Distribution Unlimited

20000727 287

Design Philosophy and Material Choice for a Tuner in an Electromagnetic Reverberation Chamber

Frank Weeks and Kevin Goldsmith

**Air Operations Division
Aeronautical and Maritime Research Laboratory**

DSTO-TN-0257

ABSTRACT

This note addresses the design philosophy and material choice for the tuner in the Defence Science and Technology Organisation (DSTO) electromagnetic combined-mode reverberation chamber. Restricting factors on the material choice are discussed, in addition to tuner and gearbox design requirements.

Approved for Public Release

Published by

*DSTO Aeronautical and Maritime Research Laboratory
PO Box 4331
Melbourne Victoria 3001 Australia*

*Telephone: (03) 9626 7000
Fax: (03) 9626 7999
© Commonwealth of Australia 2000
AR-011-234
February 2000*

APPROVED FOR PUBLIC RELEASE

Design Philosophy and Material Choice for a Tuner in an Electromagnetic Reverberation Chamber

Executive Summary

The materials used for the tuner in the DSTO combined-mode chamber were selected from readily available commercial materials. This was in keeping with the philosophy of the research chamber being used as a model for a larger test chamber suitable for the testing of large aircraft.

As the electromagnetic reverberation chamber was intended to be used for Transverse Electromagnetic (TEM) cell research as well as mode stirred research, there was a requirement to have a change-over frequency range when swapping from one test mode to the other. This required the chamber's mode stirrer to operate at low frequencies (A chamber operation frequency of <25MHz if possible.). As lower frequencies can be stirred more efficiently with a single large tuner rather than with several small tuners, a large tuner was selected. Rigidity and lightweight characteristics were desirable to minimise paddle oscillation when stopping and to keep inertia forces low. This was achieved by using rectangular steel tubing to support laminated foam panels. Commercial James Hardie Bondor™ panels were found to give the required rigidity, while being lightweight, and possessing suitable radio frequency reflectivity qualities.

The tuner drive was achieved by the combination of a commercial motor and gearbox assembly combined, with two toothed-belt drives, giving a total reduction of 1419:1. Toothed-belt gears and tensioning pulleys reduced the inherent gearbox backlash to an acceptable level, resulting in a stepping resolution of less than 0.1°.

Contents

1. INTRODUCTION.....	1
2. TUNER PARAMETERS	2
2.1 Modes of operation.....	2
2.1.1 Continuous rotation.....	2
2.1.2 Stepping mode	2
3. TUNERS	2
3.1 Large tuners versus small tuners.....	2
3.2 Tuner mounts	3
3.3 Paddle angles.....	3
4. MATERIALS	4
4.1 Material selection criteria.....	4
4.2 Paddle material RF reflectivity.....	5
5. TUNER CONSTRUCTION	6
6. GEARBOX.....	7
6.1 Gearbox requirements.....	7
6.2 Motor gearbox and motor controller.....	8
6.3 Alignment of gearbox and paddle bearings	8
6.4 Electromagnetic seal	9
7. TUNER PERFORMANCE.....	10
8. SUMMARY.....	10
9. REFERENCES.....	11

1. Introduction

The tuner is a major part of the combined-mode reverberation chamber, stirring the electromagnetic standing-wave pattern so that the nodes and anti-nodes are moved to all parts of the chamber.

World opinion on the characteristics of an optimum tuner is divided. Since no chamber the size of the one proposed by Defence Science and Technology Organisation (DSTO) has ever been built therefore no recognised guidelines as to the size and shape of the tuner's paddles (paddles shown in Photograph 1) exist. Various design philosophies were considered but many assumptions had to be made. As with all new designs, the resultant product evolved using the initial parameters as a guide but specific limitations throughout the process necessitated a balance between "must have", "can do" and "not possible".

A dominant feature for the materials selected and design philosophy was, "where possible, use commercially available materials". Even though the reverberation chamber is a research tool, the design philosophies may later be used as a model for the building of a larger chamber, suitable for the testing of large aircraft.

This note addresses the overall design philosophy of the tuner, and why the various construction materials and techniques were chosen. Photograph 1 shows the tuner after installation.

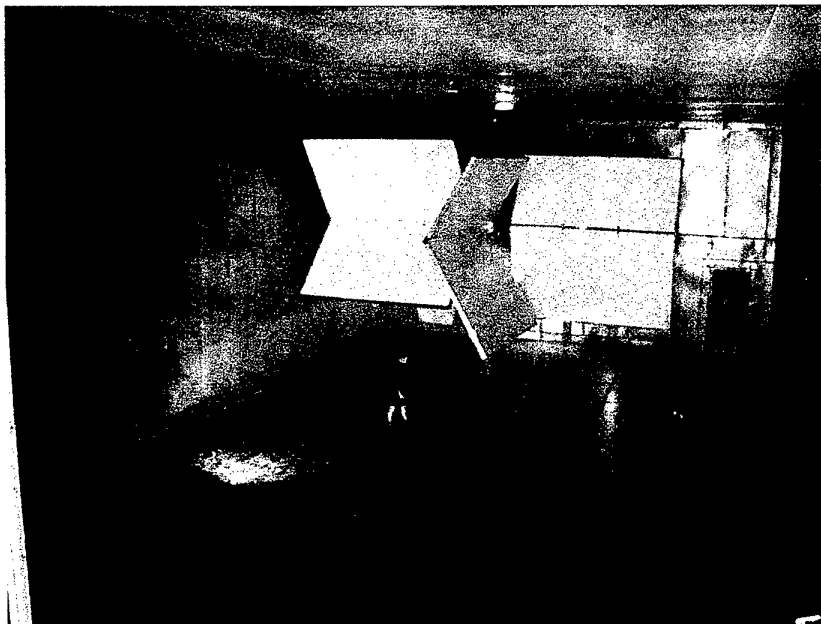

*Photograph 1: Energy Stirrer in Mode Stirred chamber
showing stirrer paddles*

2. Tuner parameters

2.1 Modes of operation

The tuner was required to operate in two modes, continuous rotation, and stepping.

2.1.1 Continuous rotation

The tuner was required to rotate at a maximum speed of 1rpm.

For simplicity of control, starting and stopping accelerations were required to be the same for both the continuous rotation and stepping modes.

Acceleration curves were calculated to ensure that the stress on the tuner structure did not exceed its material limits [1].

2.1.2 Stepping mode

The tuner was required to be capable of stepping in variable increments from 1° to continuous rotation, with a stepping resolution of 0.1° or better. Small steps are required to give a large number of independent samples when conducting experiments, in order to give good statistical results. The time taken for the oscillations of the tuner paddle to cease after the tuner has reached its desired position was required to be minimal. Overseas experience had shown that lightly-constructed tuner paddles tend to oscillate after stopping, adding considerable time to tests when the tuner is operated in stepping mode.

As with the continuous mode, maximum rotational speed during a step is to be 1rpm.

3. Tuners

3.1 Large tuners versus small tuners

World opinion varied as to what defines an optimum tuner, one large tuner versus several small tuners.

The probability of having areas of unstirred energy in the chamber is usually higher for single small tuners than when using one larger tuner, hence the need for multiple small stirrers. These unstirred areas are believed to be a contributing factor to poor low frequency performance of a chamber. A single larger tuner changes the electromagnetic

boundary conditions of the chamber substantially more than a smaller tuner, and therefore achieves more efficient tuning.

The disadvantage of a single large tuner is that it occupies a large portion of the chamber space when compared with the space taken by several small tuners.

One of the aims of the chamber was to test the ability of Transverse Electromagnetic (TEM) cell technology to extend the low-frequency end of the chamber's test spectrum. The goal was to use the TEM cell characteristics up to a frequency as high as possible, and then change to mode stirring above 30MHz. To achieve a common changeover frequency range, the relative sizes of the paddle and chamber will have to be altered to enable lower frequencies to be used with mode stirring. This goal supported the use of a single large tuner for the DSTO chamber.

Conventional opinion was that the diagonal dimension of each paddle should be a significant proportion of the wavelength λ . An arbitrary value of $\lambda/2$ at 30MHz was selected, requiring the diagonal dimension of the paddle to be greater than 5.0m.

Conventional wisdom at the time of design also suggested that one paddle dimension should be at least 60% of one of the chamber's dimensions. In our case, the chamber measures 21m x 11m x 6m, which gave a minimum paddle diagonal dimension of 3.6m.

Unfortunately the maximum size of the paddle is limited to the space left after the largest item to be tested has been placed in the chamber. Scale drawings of proposed test aircraft were superimposed on the chamber drawing. From this, the tuner's position and maximum tuner diameter was calculated, resulting in each paddle being 3.6m x 3.6m with a diagonal dimension of 5.1m. The overall tuner diameter is 8m.

3.2 Tuner mounts

The initial proposal was to have the tuner suspended from the ceiling, allowing the space under the tuner to be used as part of the working area. After selecting the size of the paddles, the space left under the paddles was only 1.5m. This is of little use when testing aircraft. It was decided not to sacrifice paddle size and hence chamber performance in the pursuit of extra working space. This decision meant that there was no longer a need for the tuner to be suspended solely from the ceiling. To achieve overall rigidity and ease of construction the free end of the tuner was to be attached to the chamber floor.

3.3 Paddle angles

The tuner was to have four paddles, with each paddle being bent along its centreline. Each paddle was to be bent at a different angle to reflect the transmitted radio frequency energy randomly throughout the reverberation chamber.

Several different paddle angles were analysed using the General Electromagnetic Model for the Analysis of Complex Systems (GEMACS) computer modelling program [2]. GEMACS gave an indication of suitable paddle angles but, due to the coarseness of the model data, it could not compute the optimum paddle angles. Paddle angles of 100°, 120°, 140° and 160° were selected. Since the optimum angles for the paddles were unknown, it was decided to incorporate the capability to be able to rotate each paddle through 20°, giving operators the flexibility to optimise the tuner as experience was gained. Support spigots were designed into the paddle end flanges, allowing the paddles to be easily rotated to achieve optimum tuning (Photograph 2).

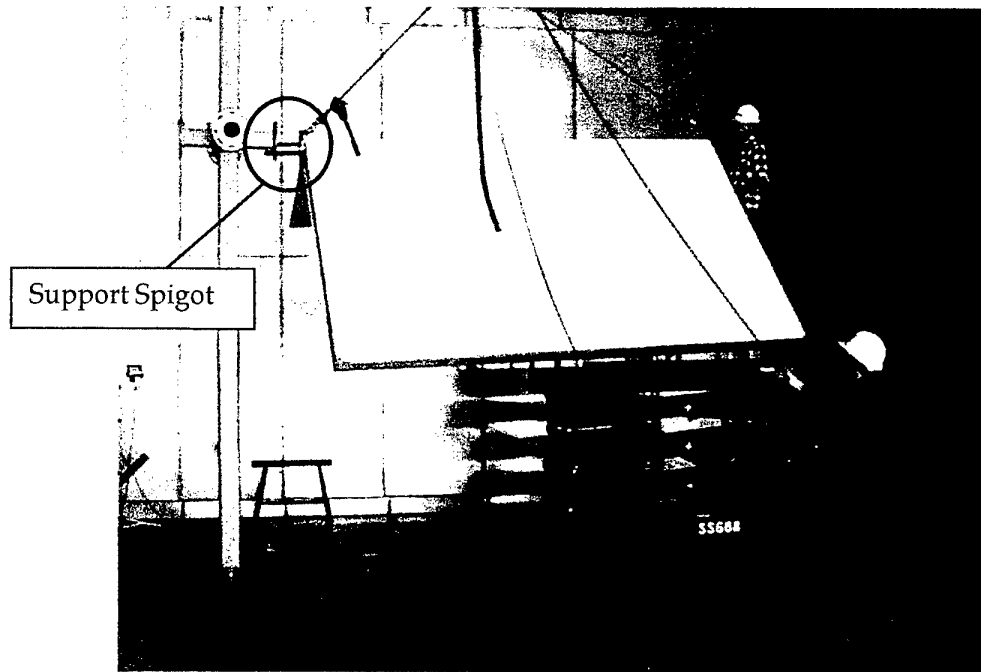

Photograph 2: Paddle being installed

4. Materials

4.1 Material selection criteria

A prime design goal in selecting materials was to use commercially available materials where possible. Even though the DSTO reverberation chamber is a research tool, it was desirable for the chamber to be at least partially representative of a larger,

commercially built chamber so that a reasonable evaluation of construction techniques could be made.

4.2 Paddle material RF reflectivity

The optimum paddle skin material is one with high RF reflective properties. Comparisons of relative conductivity were made [3],

- copper 1.0,
- aluminium 0.6,
- zinc 0.3, and
- steel 0.1.

In line with the material selection criteria, copper paddles were considered to be cost and weight prohibitive, leaving aluminium as the next choice.

An aluminium skinned space frame was first proposed, but alternative construction methods were also considered. An investigation was undertaken to find commercially available materials suitable for the construction of the tuner. A suitable material, Bondor™, was found to be manufactured by James Hardie for use in the building of cool rooms. When comparing the two construction methods the Bondor™ panels gave a lighter more rigid construction. These panels consisted of a polystyrene core with thin (0.6mm) zinc-coated steel facing sheets. The panels were available in varying thicknesses, enabling a panel with suitable rigidity to be chosen.

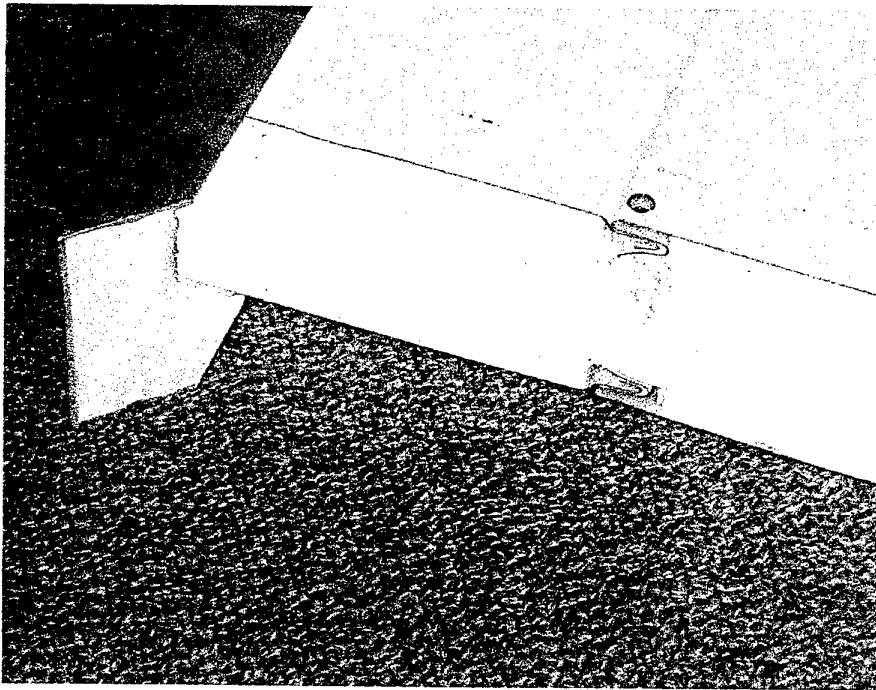

Photograph 3: Bondor™ panelling and edge capping

For an additional cost, James Hardie were willing to do a special production run and manufacture panels with aluminium facing sheets. However, as only twelve sheets were required and James Hardie had a minimum run of 150m, it was uneconomical to request a special run and did not fit into the "where possible use commercially available materials" policy. Zinc-coated steel was finally chosen as the paddle reflective surface. If zinc-coated steel was subsequently found to be unsuitable, the option of skinning the Bondor™ material with aluminium was still possible.

By using Bondor™ panels, the support frame could utilise light-weight construction techniques since the material had high natural rigidity and could be easily clipped together to form a panel of any width. Also available was extruded aluminium capping which could be used to seal the paddle edges. As shown in Photograph 3.

5. Tuner construction

The tuner consists of a centre beam supported at the roof and floor of the chamber.

The centre beam, 100mm square hollow tube, is driven from the roof by an electric motor with 10.16Nm of torque, through a 1419:1 reduction gearbox.

Four solid blocks were welded to the main beam, with each block being machined to accept a spigot on the paddle. This provides a guide to enable easy installation of the paddle assembly as well as acting as a bearing surface for easy rotation of the paddle during angle adjustments (see Photograph 2).

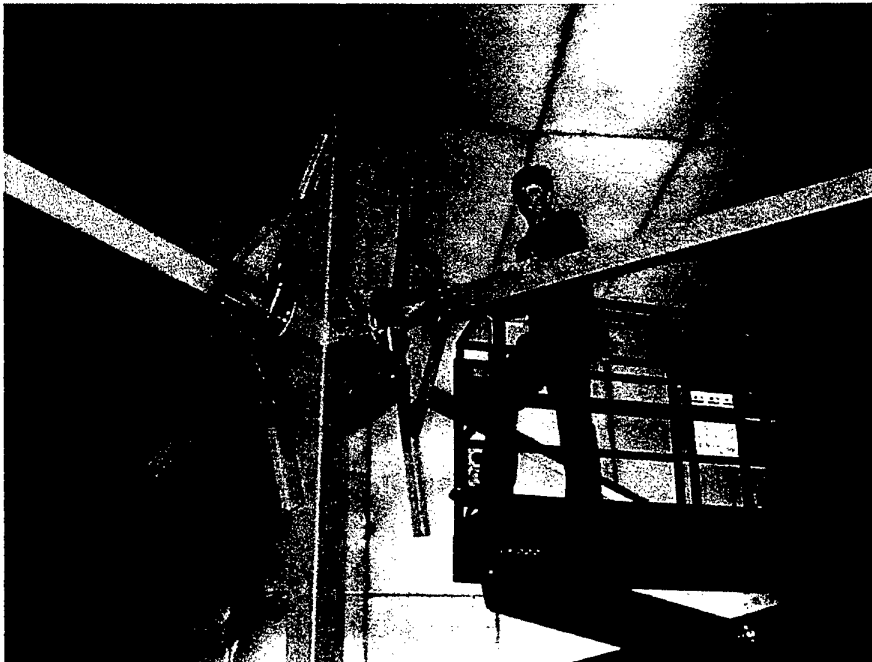

Photograph 4: Paddle frame being trial fitted

The frame work that supports each paddle is shown in Photograph 4. This consists of a centre back-bone beam, 100mm x 50mm hollow section. Welded to the beam are two support channels with extra strengthening webs. These channels support the Bondor™ panels. The skin of the Bondor™ panels was pop-riveted to the centre back-bone and support channels.

Detailed construction and stress calculations of the tuner can be found in reference [1].

6. Gearbox

6.1 Gearbox requirements

The gearbox was required to reduce the electric motor speed of 1440rpm in order to produce a tuner speed, as close as practicable to 1rpm. As the tuner was required to step in increments of 1° with a resolution of 0.1° or better, an anti-backlash gearbox was required. As anti-backlash gearboxes of this size are not commercially available, a special gearbox had to be made. With the criterion of using commercially available items where possible, other methods to reduce the backlash were investigated. As size was not a restriction, it was decided to use a combination of a commercial gearbox and toothed belt drives to produce the desired reduction ratio of 1440:1. A commercial motor and gearbox combination gave a reduction ratio of 30.16:1. When combined with two commercial toothed belt drives, each of 6.86:1 ratio, this gave a total reduction ratio of 1419:1. The toothed belt gears with tensioning pulleys would eliminate backlash in that part of the speed reduction system. The reduction ratio of the toothed belt gears was 47.06:1, which reduced the effect of the gearbox's backlash by 47 times.

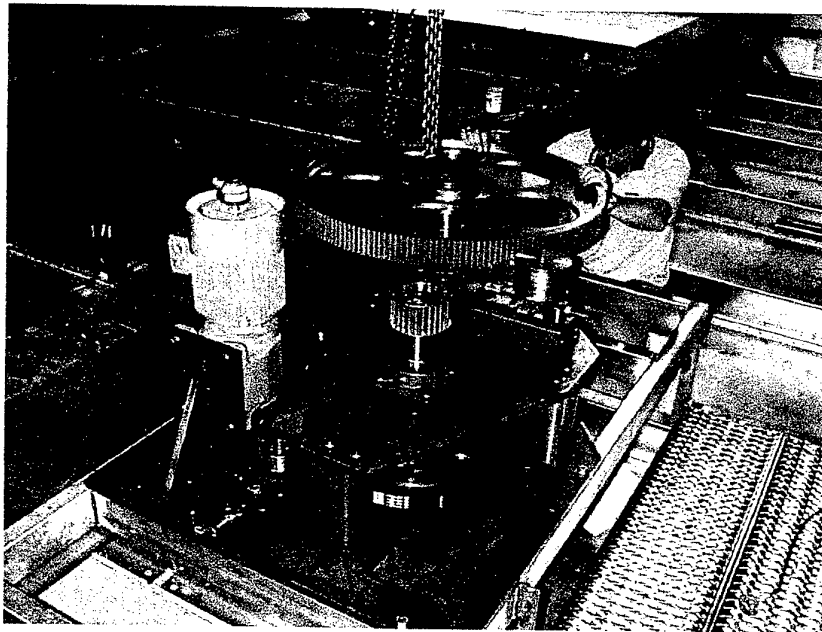

Photograph 5: Gearbox and drive motor assembly

6.2 Motor gearbox and motor controller

A commercial drive motor and gearbox, SEW Eurodrive motor DT90L4, was selected for the tuner's drive system. This consisted of a 10.16Nm torque electric motor and a gearbox with close cut gears to give minimal backlash. The motor was controlled using a SEW Movitrac 3000/31 inverter.

6.3 Alignment of gearbox and paddle bearings

The construction of the gearbox and the paddle main shaft was such that the 3 bearings were used on a single shaft; two in the gearbox and one on the end of the stirrer's main shaft. The two bearings in the gearbox were located some 6.5m away from the bearing supporting the tuner main shaft. The alignment of the two gearbox bearings and the paddle support bearing located on the floor of the chamber was done using a laser pointer in a dummy gearbox shaft (see Photograph 6 and Figure 1). A separate shaft was manufactured to fit into the 2 gearbox main shaft bearings. This shaft had a hole drilled through the centre to locate a commercial laser pointer. Several extra holes were drilled to align the laser pointer and to allow it to be turned on and off. Levelling screws, located in the bottom gearbox plate, were used to align the gearbox. A plumb bob was dropped from the centre of the main shaft to locate the centre position of the paddle support bearing on the floor of the chamber. The laser pointer was then installed in the hollow shaft. As the dummy shaft was rotated, the laser pointer projected a circle around the centre-line axis of the two gearbox bearings. By adjusting the gearbox levelling screws, the centre of the projected circle was moved to coincide with the plum bob centre, thereby aligning all three bearings.

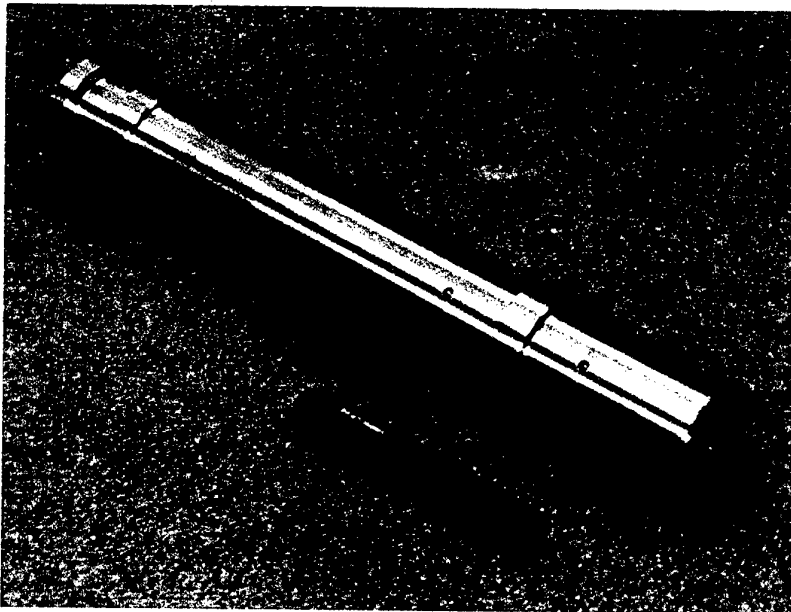

Photograph 6: Dummy shaft and laser pointer used to align gearbox bearings

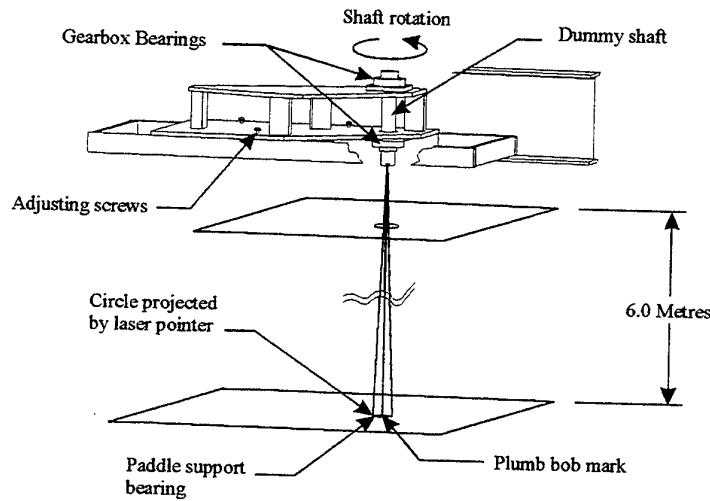

Figure 1 Aligning gearbox bearings using laser point

6.4 Electromagnetic seal

An electromagnetic seal between the gearbox drive shaft and chamber skin was manufactured in-house. This featured a close tolerance fit between the shaft and seal body, with a maximum clearance of 0.05mm. The seal consisted of a hollow copper earth strapping cable into which was inserted a foam rubber core. This expanded the strapping material, ensuring electrical contact between the shaft and seal case, and at the same time minimised the gap between the shaft and seal body (see Figure 2). This seal has been found to be suitable up to frequencies of 1GHz but, as yet, has not been tested at higher frequencies.

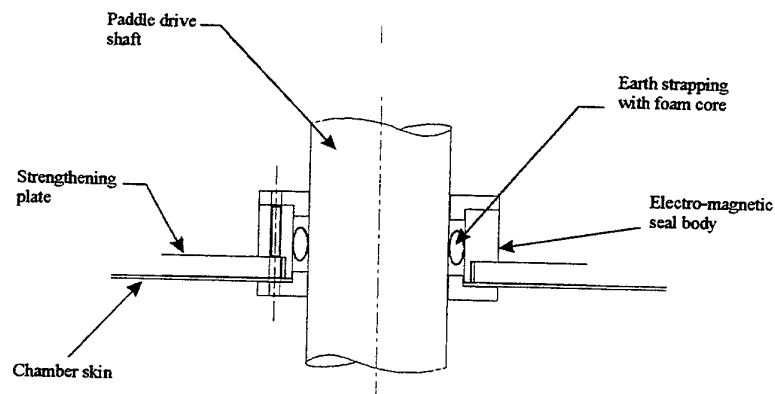

Figure 2 Electromagnetic seal

7. Tuner Performance

The quantitative links between tuner design parameters and performance are not presently known. This tuner has been designed using state-of-the-art empirical knowledge. Additionally there are no current procedures for evaluating tuner performance.

The current empirical expectation is that a chamber will operate in a reverberant manner when the injected RF has a frequency such that there are 60 lower frequencies at which a chamber mode may exist (60 mode rule). For the DSTO chamber this frequency is approximately 63MHz. The lowest frequency standing mode that may exist in the chamber is 15.5MHz.

A measure of the tuner performance is the ratio of frequencies between the lowest mode frequency and the frequency at which the chamber ceases to have a chi-squared field distribution. In the DSTO chamber, with a Black Hawk aircraft inside, the frequency at which the chamber ceased having a Kolmogorov-Smirnov [4] probability test ratio of >0.9 was 30MHz. The tuner performance ratio is therefore approximately 2. This is significantly better than the 4:1 ratio expected by using the 60 mode rule. This tuner is therefore considered to be excellent using this measurement of performance. FOA [5] has two chambers with tuners that are small relative to the size of the chamber they are in. The smaller/larger chamber (E3) at FOA shows that this chamber has a tuner performance ratio of 7:1 for their larger tuner and 10:1 for their small tuner. This shows that the DSTO tuner design is superior using the Kolmogorov-Smirnov measurer of performance.

The tuner in the DERA chamber [6] is also relatively large compared with the chamber and has a performance ratio of 2.5:1. As a result this tuner also works very efficiently.

8. Summary

The materials used for the tuner in the DSTO combined mode chamber were selected from readily available commercial materials where possible. This was in keeping with the philosophy of the chamber being used as a model for a larger test chamber aimed at the testing of large aircraft.

A single large tuner was selected over several smaller tuners in order to extend the chamber's low frequency capability. The tuner frame was constructed with hollow steel tubing. To reduce paddle oscillation to a minimum, the paddles were designed to be rigid and lightweight. The James Hardie Bondor™ material was found to have suitable rigidity and good electromagnetic reflectivity characteristics.

The tuner's drive gearbox consisted of a commercial electric motor and gearbox, combined with two toothed-belt drives to give a total reduction ratio of 1419:1. The toothed belt gears and tensioning pulleys reduced the gearbox backlash to an acceptable level and gave a stepping resolution of less than 0.1°.

The large tuner used in the DSTO chamber was found to be very efficient, with the lowest frequencies giving a mode-to-frequency ratio of 2:1. This was encouraging, as tuners used in overseas chambers do not show the same efficiency.

9. References

- 1 Weeks, F., "Stress analyses of an energy tuner used in a Electromagnetic Reverberation chamber", DSTO-TN-0272
2. "Computational Electromagnetic Modeling of an Aircraft-Sized Reverberation Chamber", Paul A. Johnson and Kevin R. Goldsmith To be published
- 3 Tecknit, EMI Shielding Design Guide
- 4 Press W. H. et al., "Numerical Recipes", pub. Cambridge, pp. 472-475 (1986)
- 5 FOA Defence Research Establishment, Technical Report FOA-r-99-01139-612-SE May 1999 ISSN 1104-9154, "Measurements of Stirrer Efficiency in Mode-Stirred Reverberation Chambers" by Olof Lunden, Leif Jansson and Mats Bachstrom.
- 6 HIRF home page, <http://dspace.dial.pipex.com/town/plaza/g566/index.htm>

DISTRIBUTION LIST

Design Philosophy and Material Choice for a Tuner in an Electromagnetic Reverberation Chamber.

Frank Weeks and Kevin Goldsmith

AUSTRALIA

DEFENCE ORGANISATION

Task Sponsor RAAF, DGTA

S&T Program

Chief Defence Scientist
FAS Science Policy
AS Science Corporate Management
Director General Science Policy Development
Counsellor Defence Science, London (Doc Data Sheet)
Counsellor Defence Science, Washington (Doc Data Sheet)
Scientific Adviser to MRDC Thailand (Doc Data Sheet)
Scientific Adviser Policy and Command
Navy Scientific Adviser (Doc Data Sheet and distribution list only)

Scientific Adviser - Army (Doc Data Sheet and distribution list only)

} shared copy

Air Force Scientific Adviser
Director Trials

Aeronautical and Maritime Research Laboratory
Director

Electronics and Surveillance Research Laboratory
Director (Doc Data Sheet and Distribution List only)

Chief of Air Operations Division (AOD)
Research Leader RLAFM, N. Pollock
Head HAV, P. Urlings
Task Manager APR97/K 123, T Priest, Avionics, AOD
Author(s): F. Weeks, AOD
K Goldsmith, Avionics, AOD

DSTO Research Library and Archives

Library Fishermans Bend
Library Maribyrnong
Library Salisbury (2 copies)
Australian Archives
Library, MOD, Pyrmont (Doc Data sheet only)
US Defense Technical Information Center, 2 copies

UK Defence Research Information Centre, 2 copies
Canada Defence Scientific Information Service, 1 copy
NZ Defence Information Centre, 1 copy
National Library of Australia, 1 copy

Capability Systems Staff

Director General Maritime Development (Doc Data Sheet only)
Director General C3I Development (Doc Data Sheet only)
Director General Aerospace Development

Navy

SO (Science), Director of Naval Warfare, Maritime Headquarters Annex,
Garden Island, NSW 2000. (Doc Data Sheet only)

Army

ABCA Standardisation Officer, Puckapunyal, (4 copies)
SO (Science), DJFHQ(L), MILPO Enoggera, Queensland 4051 (Doc Data Sheet
only)

Air Force

SCI2, LSA, SQNLDR M. Wade
SCI2a, LSA, FLTLT G. Gallagher

Intelligence Program

DGSTA Defence Intelligence Organisation
Manager, Information Centre, Defence Intelligence Organisation

Corporate Support Program

OIC TRS, Defence Regional Library, Canberra

UNIVERSITIES AND COLLEGES

Australian Defence Force Academy
Library
Head of Aerospace and Mechanical Engineering
Hargrave Library, Monash University, (Doc Data Sheet only)
Librarian, Flinders University

OTHER ORGANISATIONS

NASA (Canberra)
Info Australia (formerly AGPS)

OUTSIDE AUSTRALIA

ABSTRACTING AND INFORMATION ORGANISATIONS

Library, Chemical Abstracts Reference Service
Engineering Societies Library, US
Materials Information, Cambridge Scientific Abstracts, US

Documents Librarian, The Center for Research Libraries, US

INFORMATION EXCHANGE AGREEMENT PARTNERS

Acquisitions Unit, Science Reference and Information Service, UK

Library - Exchange Desk, National Institute of Standards and Technology, US

National Aerospace Laboratory, Japan

National Aerospace Laboratory, Netherlands

SPARES (5 copies)

Total number of copies: 51

DEFENCE SCIENCE AND TECHNOLOGY ORGANISATION DOCUMENT CONTROL DATA				1. PRIVACY MARKING/CAVEAT (OF DOCUMENT)	
2. TITLE Design Philosophy and Material Choice for a Tuner in an Electromagnetic Reverberation Chamber			3. SECURITY CLASSIFICATION (FOR UNCLASSIFIED REPORTS THAT ARE LIMITED RELEASE USE (L) NEXT TO DOCUMENT CLASSIFICATION) Document (U) Title (U) Abstract (U)		
4. AUTHOR(S) Frank Weeks and Kevin Goldsmith			5. CORPORATE AUTHOR Aeronautical and Maritime Research Laboratory PO Box 4331 Melbourne Vic 3001 Australia		
6a. DSTO NUMBER DSTO-TN-0257		6b. AR NUMBER AR 011-234		6c. TYPE OF REPORT Technical Note	
7. DOCUMENT DATE February 2000					
8. FILE NUMBER M1/9/705		9. TASK NUMBER Air 97/123		10. TASK SPONSOR RAAF DGTA	
11. NO. OF PAGES 11			12. NO. OF REFERENCES 6		
13. URL ON WORLDWIDE WEB http://www.dsto.defence.gov.au/corporate/reports/DSTO-TN-0257.pdf				14. RELEASE AUTHORITY Chief, Air Operations Division	
15. SECONDARY RELEASE STATEMENT OF THIS DOCUMENT <i>Approved for Public Release</i>					
OVERSEAS ENQUIRIES OUTSIDE STATED LIMITATIONS SHOULD BE REFERRED THROUGH DOCUMENT EXCHANGE, PO BOX 1500, SALISBURY, SA 5108					
16. DELIBERATE ANNOUNCEMENT No Limitations					
17. CASUAL ANNOUNCEMENT No					
18. DEFTEST DESCRIPTORS Electromagnetic reverberation chambers, Electromagnetic frequency; Transverse electromagnetic cells; Testing chambers					
19. ABSTRACT This note addresses the design philosophy and material choice for the tuner in the Defence Science and Technology Organisation (DSTO) combined-mode electromagnetic reverberation chamber. Restricting factors on the material choice are discussed, as well as tuner and gearbox design requirements.					