

FINAL REPORT

CONTRACT F61775-99-WE073

VALERY VOEVODINE

**R&D CENTER "ATOM – ADVANCED TECHNOLOGIES
FOR OPTICAL MATERIALS"
1, REVOLUTION SQUARE
TOMSK, 634050, RUSSIA**

10 FEBURARY 2000

20000731 094

AQF00-10-3090

REPORT DOCUMENTATION PAGE

Form Approved OMB No. 0704-0188

Public reporting burden for this collection of information is estimated to average 1 hour per response, including the time for reviewing instructions, searching existing data sources, gathering and maintaining the data needed, and completing and reviewing the collection of information. Send comments regarding this burden estimate or any other aspect of this collection of information, including suggestions for reducing this burden to Washington Headquarters Services, Directorate for Information Operations and Reports, 1215 Jefferson Davis Highway, Suite 1204, Arlington, VA 22202-4302, and to the Office of Management and Budget, Paperwork Reduction Project (0704-0188), Washington, DC 20503.

1. AGENCY USE ONLY (Leave blank)		2. REPORT DATE 10 February 2000	3. REPORT TYPE AND DATES COVERED Final Report	
4. TITLE AND SUBTITLE Nonlinear Optical Materials			5. FUNDING NUMBERS F61775-99-WE073	
6. AUTHOR(S) Dr. Valeri G. Voevodin				
7. PERFORMING ORGANIZATION NAME(S) AND ADDRESS(ES) Advanced Technologies for Optical Materials (ATOM) 1, Revolution sq., Tomsk 634050 Russia			8. PERFORMING ORGANIZATION REPORT NUMBER N/A	
9. SPONSORING/MONITORING AGENCY NAME(S) AND ADDRESS(ES) EOARD PSC 802 BOX 14 FPO 09499-0200			10. SPONSORING/MONITORING AGENCY REPORT NUMBER SPC 99-4073	
11. SUPPLEMENTARY NOTES				
12a. DISTRIBUTION/AVAILABILITY STATEMENT Approved for public release; distribution is unlimited.			12b. DISTRIBUTION CODE A	
13. ABSTRACT (Maximum 200 words) This report results from a contract tasking Advanced Technologies for Optical Materials (ATOM) as follows: The contractor will grow and deliver a number of samples of ZnGeP ₂ , CdGeAs ₂ , and GaSe for characterization by AFRL/MLPO for possible use in tunable lasers in the mid- and far-IR.				
14. SUBJECT TERMS EOARD, Non-linear Optical Materials , Tunable lasers, Chalcopyrite materials			15. NUMBER OF PAGES 8	
			16. PRICE CODE N/A	
17. SECURITY CLASSIFICATION OF REPORT UNCLASSIFIED	18. SECURITY CLASSIFICATION OF THIS PAGE UNCLASSIFIED	19. SECURITY CLASSIFICATION OF ABSTRACT UNCLASSIFIED	20. LIMITATION OF ABSTRACT UL	

NSN 7540-01-280-5500

DMC QUALITY INSPECTED 4

Standard Form 298 (Rev. 2-89)
Prescribed by ANSI Std. Z39-18
298-102

**OPTICAL ELEMENTS
SPECIFICATION # 1**

MATERIAL: Zinc Germanium Phosphide , doped by scandium, $\text{ZnGeP}_2\langle\text{Sc}\rangle$

ORIENTATION : $\theta = 90^\circ$; $\varphi = 0^\circ$; plane (100)

APERTURE : $10 \times 7 \text{ mm}^2$

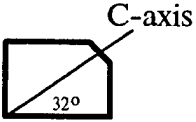
Element #	Thickness, mm	\bar{C} -axis -direction (schematic)
1	0.92	
2	0.92	

Note: As-grown samples, without any improving annealing

Address: 1, Revolution Sq., Tomsk, 634050, Russia

Phones: (382-2) 41-3636, 41-3479 **Fax:** (382-2) 41-3636 **Email:** voevodin@elefot.tsu.ru

R@D Center "ATOM - Advanced Technologies for Optical Materials"

OPTICAL ELEMENTS SPECIFICATION # 2

MATERIAL: Cadmium Germanium Arsenide, CdGeAs₂

ORIENTATION : $\theta = 90^\circ$; $\varphi = 0^\circ$; plane (100)

APERTURE : $(7 \pm 0.3) \times (5 \pm 0.3)$ mm²

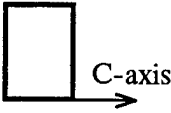
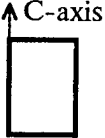
Element #	Thickness, mm	\vec{C} -axis -direction (schematic)
3	0.67	
4	0.68	
5	0.88	
6	0.78	
7	0.78	
8	0.54	
9	0.54	
10	0.55	
11	0.55	
12	0.56	
13	0.77	
14	0.82	
15	0.88	

Address: 1, Revolution Sq., Tomsk, 634050, Russia

Phones: (382-2) 41-3636, 41-3479 **Fax:** (382-2) 41-3636 **Email:** voevodin@elefot.tsu.ru

R@D Center "ATOM - Advanced Technologies for Optical Materials"

OPTICAL ELEMENTS SPECIFICATION # 3

MATERIAL: Cadmium Germanium Arsenide, CdGeAs₂

ORIENTATION : $\theta = 0^\circ$; $\varphi = 0^\circ$; plane (001)

APERTURE : $(6 \pm 0.3) \times (6 \pm 0.5) \text{ mm}^2$

Element #	Thickness, mm
16	0.70
17	0.70
18	0.71
19	0.69
20	0.70
21	0.75
22	0.75
23	0.61
24	0.70
25	0.67
26	0.65
27	0.55
28	0.62
29	0.62
30	0.62
31*)	0.55

*) Additional, with the aperture : $(5.6) \times (5.7) \text{ mm}^2$

Address: 1, Revolution Sq., Tomsk, 634050, Russia

Phones: (382-2) 41-3636, 41-3479 **Fax:** (382-2) 41-3636 **Email:** voevodin@elefot.tsu.ru

R&D Center "ATOM - Advanced Technologies for Optical Materials"

SPECIFICATION

MATERIAL	Zinc Germanium Phosphide The bulk material is homogeneous and single domain with no striae	
CUT	Type I: Theta = 51 degrees, Phi = 0 degrees (tolerance +/- 0.5 degrees)	
DIMENSIONS		
APERTURE, mm×mm	8×5 (tolerance +/- 0.2 mm)	
LENGTH, mm	0.65 (tolerance +/- 0.05 mm)	
BULK ABSORPTION, cm ⁻¹	< 0.2 (non-polarized radiation)	< 0.02
AT WAVELENGTH, μm	2.1	3.5-5
END SURFACES	Flatness Scratch-dig Parallelism	Lambda/6 at 633 nm 20/10 (as per MIL-0-13830 A) < 30 arc seconds
QUANTITY, pcs	20	

SCHEMATIC

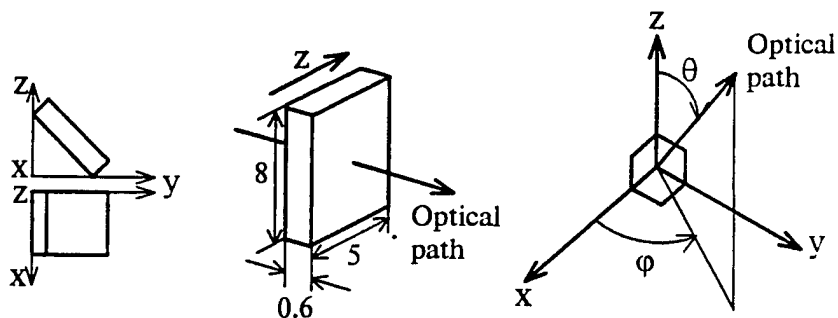

1, Revolution sq.,
634050, Tomsk, Russia

Phone/Fax: +7/382 2/413 636
Email: voevodin@elefot.tsu.ru

R@D Center "ATOM - Advanced Technologies for Optical Materials"

GaSe-element

Operating Instruction

Attention: Gallium selenide is very soft and plastic material, therefore it is necessary to eliminate, as possible, any mechanical attacks on the element.

The scheme of the element placement in the holder.

1. The nonlinear-optical GaSe-element 1 is placed on the polished basement 2 of the holder and fixed on this basement by means of synthetic glue 3 (such as "Moment").
2. The protective plate 4 is attached to the basement 2 by means of the two screws 5.
3. In order to take out the element from the holder, first you must unscrew the two screws 5 and remove the protective plate 4. Then the holder with the element is placed into dissolver (type of acetone) and held there to the glue dissolving. Next you may remove the element carefully touching neither upper nor lower sides of the element.
4. To clean the element surface from one dust one may use a soft, for example, squirrel brush. To take scratches or other injuries of working element faces you must not apply standard mechanical polish. The optical surface is restored by splitting-out a thin material layer of whole working surface of the element with the aid of a sharp blade.

Nonlinear Optical Element

SPECIFICATION

NLO element material	Gallium Selenide GaSe
Designation	GSB-158
Application	Parametric Frequency Conversion for mid IR lasers
Orientation	$\theta = 0^\circ$; x-axis direction is marked on the protective plate
Length, mm	7,5
Aperture, mm×mm	Ø12
Absorption, cm ⁻¹ at wavelength, μm	<0.1 5
AR Coating	-

Outside view

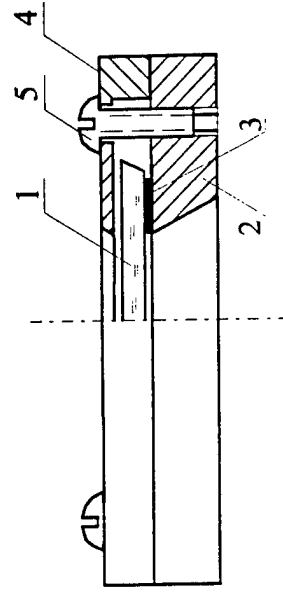

Manufacturer:

**Advanced Technologies for Optical Materials,
Tomsk, Russia**

Mail address:
1, Revolution sq. 634050, Tomsk,
Russia
Phone/Fax: +7/382 2/413 636
E-mail: voevodin@elefot.tsu.ru

NLO element material
Gallium Selenide
GaSe

Designation
GSB-159

Application
Parametric Frequency
Conversion for mid IR lasers

Orientation
 $\theta = 0^\circ$;
x-axis direction is marked
on the protective plate

Length, mm

Aperture, mm×mm
Ø5

Absorption, cm^{-1}
at wavelength, μm
5
< 0.1

AR Coating
—

Outside view

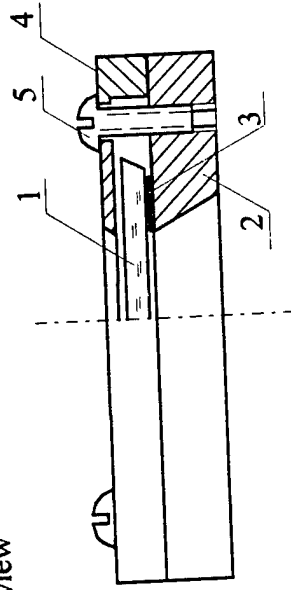

Manufacturer:

**Advanced Technologies for Optical Materials,
Tomsk, Russia**

Mail address:
1, Revolution sq. 634050, Tomsk,
Russia
Phone/Fax: +7/382 2/413 636
E-mail: voevodin@elefot.tsu.ru