

NAVAL POSTGRADUATE SCHOOL MONTEREY, CALIFORNIA



THESIS

**THE EXPERIMENTAL EVALUTATION OF A DGPS
BASED NAVIGATIONAL SYSTEM FOR THE ARIES
AUV**

by

Benjamin M. Stinespring

June 2000

Thesis Advisor:

Anthony J. Healey

Approved for public release; distribution is unlimited.

DECS QUALITY INSPECTED 4

20000731 053

REPORT DOCUMENTATION PAGE

Form Approved OMB No. 0704-0188

Public reporting burden for this collection of information is estimated to average 1 hour per response, including the time for reviewing instruction, searching existing data sources, gathering and maintaining the data needed, and completing and reviewing the collection of information. Send comments regarding this burden estimate or any other aspect of this collection of information, including suggestions for reducing this burden, to Washington Headquarters Services, Directorate for Information Operations and Reports, 1215 Jefferson Davis Highway, Suite 1204, Arlington, VA 22202-4302, and to the Office of Management and Budget, Paperwork Reduction Project (0704-0188) Washington DC 20503.

1. AGENCY USE ONLY (Leave blank)		2. REPORT DATE June 2000	3. REPORT TYPE AND DATES COVERED Master's Thesis	
4. TITLE AND SUBTITLE: The Experimental Evaluation of a DGPS Based Navigation System for the ARIES AUV			5. FUNDING NUMBERS	
6. AUTHOR(S) Stinespring, Benjamin M.			N 0001499AF00002	
7. PERFORMING ORGANIZATION NAME(S) AND ADDRESS(ES) Naval Postgraduate School Monterey CA 93943-5000			8. PERFORMING ORGANIZATION REPORT NUMBER	
9. SPONSORING/MONITORING AGENCY NAME(S) AND ADDRESS(ES) Office of Naval Research, 800 N. Quincy St., Arlington, VA 22217-5660			10. SPONSORING/MONITORING AGENCY REPORT NUMBER	
11. SUPPLEMENTARY NOTES The views expressed in this thesis are those of the author and do not reflect the official policy or position of the Department of Defense or the U.S. Government.				
12a. DISTRIBUTION/AVAILABILITY STATEMENT Approved for public release; distribution is unlimited.			12b. DISTRIBUTION CODE	
13. ABSTRACT (maximum 200 words) Autonomous Underwater Vehicles (AUV) currently use varying methods for navigation, but incorporating GPS into those methods is becoming a popular technique. This thesis experimentally evaluates the configuration and implementation of the Navigational Suite within the Naval Postgraduate School's AUV, the ARIES (Acoustic Radio Interactive Exploratory Server). Specific attention is given to the configuration of the vehicle's newly completed DGPS (Differential Global Positioning System). A brief discussion of DGPS and Extended Kalman Filter theory continues with a description of the make-up and applications of components within the Suite. Details of a series of experiments, which begins with evaluation of the DGPS setup, then qualifies the system in an open-water environment, and finally qualifies the DGPS in conjunction with newly configured ARIES Navigational Filter, provide an examination of the Suite's performance.				
14. SUBJECT TERMS: Autonomous Underwater Vehicles, Differential Global Positioning System, Extended Kalman Filtering, Underwater Navigation, Robotics.			15. NUMBER OF PAGES 202	
			16. PRICE CODE	
17. SECURITY CLASSIFICATION OF REPORT Unclassified	18. SECURITY CLASSIFICATION OF THIS PAGE Unclassified	19. SECURITY CLASSIFICATION OF ABSTRACT Unclassified	20. LIMITATION OF ABSTRACT UL	

NSN 7540-01-280-5500

Standard Form 298 (Rev. 2-89)
Prescribed by ANSI Std. Z39-18 298-102

Approved for public release; distribution is unlimited.

THE EXPERIMENTAL EVALUTATION OF A DGPS BASED
NAVIGATIONAL SYSTEM FOR THE ARIES AUV

Benjamin M. Stinespring
Ensign, United States Navy
B.A., United States Naval Academy, 1999

Submitted in partial fulfillment of the
Requirements for the degree of

MASTER OF SCIENCE IN MECHANICAL ENGINEERING

from the

NAVAL POSTGRADUATE SCHOOL
June 2000

Author:

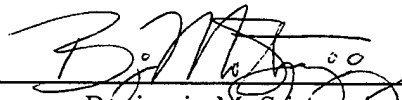
Benjamin M. Stinespring

Approved by:

Anthony J. Healey, Thesis Advisor

Terry R. McNelley, Chairman
Department of Mechanical Engineering

ABSTRACT

Autonomous Underwater Vehicles (AUV) currently use varying methods for navigation, but incorporating GPS into those methods is becoming a popular technique. This thesis experimentally evaluates the configuration and implementation of the Navigational Suite within the Naval Postgraduate School's AUV, the ARIES (Acoustic Radio Interactive Exploratory Server). Specific attention is given to the configuration of the vehicle's newly completed DGPS (Differential Global Positioning System). A brief discussion of DGPS and Extended Kalman Filter theory continues with a description of the make-up and applications of components within the Suite. Details of a series of experiments, which begins with evaluation of the DGPS setup, then qualifies the system in an open-water environment, and finally qualifies the DGPS in conjunction with newly configured ARIES Navigational Filter, provide an examination of the Suite's performance.

TABLE OF CONTENTS

I.	INTRODUCTION.....	1
A.	BACKGROUND.....	1
B.	CURRENT NAVIGATION METHODS.....	2
C.	THESIS SCOPE.....	4
II.	GLOBAL POSITIONING SYSTEM.....	7
A.	INTRODUCTION.....	7
1.	GPS.....	7
2.	Differential GPS.....	12
B.	ARIES DGPS SYSTEM.....	13
1.	System Constraints.....	14
2.	System Solution.....	15
III.	ARIES NAVIGATIONAL SUITE.....	17
A.	INTRODUCTION.....	17
1.	Navigational Suite Overview.....	17
B.	SYSTEM COMPONENTS.....	19
1.	Base-Station Hardware.....	20
a.	The Differential Receiver and Beacon.....	20
b.	The Radio Modem.....	22
2.	AUV Hardware.....	23
a.	The GPS Receiver and Aerial.....	23
b.	Command/Control Antenna and Multiplexer.....	26
c.	Sonar Doppler Velocity Log.....	27
d.	IMU.....	28
e.	Depth Cell.....	29
3.	System Software.....	30
a.	Procomm Plus (Radio Modem).....	30
b.	Command Message Software (ABX-3 and MBL-3).....	30
IV.	KALMAN FILTERING.....	33
A.	INTRODUCTION.....	33
B.	KALMAN FILTER THEORY.....	33
1.	Discrete Kalman Algorithms.....	33
2.	Continuous State Model.....	36

C.	ARIES NAVIGATIONAL FILTER	38
1.	Data Pre-Processing	39
2.	A Matrix	40
3.	Q Matrix and System Noise	41
4.	Asynchronous Data Processing	42
a.	Asynchronous Data Problem.....	43
b.	Asynchronous Data Solution.....	43
V.	RESULTS OF EXPERIMENTATION.....	47
A.	INTRODUCTION.....	47
B.	EVALUATION OF DGPS SETUP	47
1.	Stationary Test.....	49
2.	Motion Tests.....	56
3.	Shape Test	60
C.	OPEN-WATER QUALIFICATION OF THE DGPS.....	64
1.	First Test Results	65
2.	System Troubleshooting.....	71
3.	Second Test Results	72
D.	EVALUATION OF THE DGPS BASED NAVIGATIONAL FILTER.....	77
1.	Navigation Filter.....	78
2.	Filter Adjustments	90
VII.	CONCLUSIONS AND RECOMMENDATIONS.....	99
A.	CONCLUSIONS	99
B.	RECOMMENDATIONS	99
	APPENDIX A. NMEA MESSAGE FORMAT	101
	APPENDIX B. MATLAB CODE ASSOCIATED WITH ANALYSIS OF INITIAL GPS EVALUATION	105
	APPENDIX C. MATLAB CODE ASSOCIATED ARIES NAVGATIONAL FILTER	109
	LIST OF REFERENCES	119
	INITIAL DISTRIBUTION LIST	121

LIST OF FIGURES

Figure 2.1	GPS Constellation [Ref. 8].....	8
Figure 2.2	GPS Satellite Triangulation [Ref. 8]	9
Figure 2.3	Geometric Dillution of Precision [Ref. 8].....	10
Figure 2.4	DGPS Position Correction [Ref. 8].....	12
Figure 3.1	ARIES AUV Computer Architecture.....	18
Figure 3.2	ARIES Navigational Suite Diagram.....	19
Figure 3.3	DGPS Base-Station Configuration.....	20
Figure 3.4	Differential Receiver and Beacon [Ref. 5].....	21
Figure 3.5	A <i>Freewave</i> Radio Modem Pair [Ref. 5]	23
Figure 3.6	DGPS AUV Configuration.....	24
Figure 3.7	Ashtech 'G-12' GPS Receiver [Ref. 12].....	25
Figure 3.8	Mounted GPS Aerial and Cable Hull Penetration.....	26
Figure 3.9	Two-way Command/Control and Differential Corrections Antenna	27
Figure 3.10	<i>RDI</i> 'Workhorse Navigator' Sonar Doppler Velocity Log [Ref. 14].....	28
Figure 3.11	<i>Systron Donner</i> 'IMU' [Ref. 15].....	29
Figure 3.12	<i>PSI Tronix</i> 'PWC' PressureTransducer/Transmitter [Ref. 16]	29
Figure 5.1	Stationary Test Geographic Plot	50
Figure 5.2	Histogram of Stationary Test Satellites.....	52
Figure 5.3	Stationary Test DOP Plot	53
Figure 5.4	Stationary Test Geographic Plot (Corrected)	55
Figure 5.5	Motion Test Geographic Plot	57
Figure 5.6	Histogram of Motion Test Satellites	58
Figure 5.7	Motion Test DOP Plot.....	59
Figure 5.8	Shape Test Geographic Plot	61
Figure 5.9	Histogram of Shape Test Satellites	62
Figure 5.10	Shape Test DOP Plot.....	63
Figure 5.11	Open Water Test Geographic Plot	66
Figure 5.12	Histogram of Open Water Test Satellites.....	69
Figure 5.13	Open Water Test DOP Plot	70
Figure 5.14	Open Water Test #2 Geographic Plot	74
Figure 5.15	Histogram of Open Water Test #2 Satellites.....	75
Figure 5.16	Open Water Test #2 DOP Plot	76
Figure 5.17	Filter Test #1 DGPS and Filter Track	79
Figure 5.18	Filter Test #1 AUV Heading	81
Figure 5.19	Filter Test #1 Yaw Rate Bias	82
Figure 5.20	Filter Test #1 Compass Bias.....	83
Figure 5.21	Filter Test #1 Covariance	85
Figure 5.22	Filter Test #2 DGPS and Filter Track	87
Figure 5.23	Filter Test #2 Covariance and Depth.....	89
Figure 5.24	Gain Test Data Set #2 DGPS and Original Filter Track	92
Figure 5.25	Gain Test Data Set #1 DGPS and Original Filter Track	94
Figure 5.26	Gain Test Data Set #1 DGPS and Tuned Filter Track	97

LIST OF TABLES

Table 5.1	Stationary Test Statistics	54
Table 5.2	Motion Test Statistics	56
Table 5.3	Shape Test Statistics	60
Table 5.4	Open Water Test Statistics	67
Table 5.5	Open Water Test 2 Statistics	72
Table 5.6	Initial R Gain Test Results	93
Table 5.7	Initial Q Gain Test Results	95
Table 5.8	Final Gain Test Results	96

ACKNOWLEDGMENTS

First and foremost, I would like to acknowledge my thesis advisor Prof. Anthony J. Healey for the guidance and knowledge he has imparted upon me throughout my stay at NPS. I hope I always remember the teachings he bestowed me, and reflect the patience with which he did so. I am also very grateful to Dave Marco and Robert Dayap for their time and efforts, which allowed me to conduct the necessary research to make this thesis possible.

Additionally, I am thankful for the all of the Professors, Administrators, and Staff at NPS who have contributed to my education. Your efforts to support the IGEP program, and ultimately my academic growth, will always be thankfully remembered.

Finally, I would like to thank my friends and family. The love and support my family gave me during this last year was the coxswain that kept me going when I was tired of rowing. The non-stop adventures with my friends were the opposing currents, which kept the experience so sporting. Without the perfect balance of both, I would have never made it.

I. INTRODUCTION

A. BACKGROUND

The number of missions that can benefit from the utilization of an Autonomous Underwater Vehicle (AUV) grows every day. An AUV makes it possible to complete underwater tasks, with minimal support and supervision. Potential uses for the vehicles include arctic under ice exploration, offshore oil platform examining, ocean feature mapping, mine countermeasure operations, and underwater object location and positioning such as fiber-optic cables and oil pipelines. It is also important to realize these missions require an AUV that can accurately determine its geographic position. In most instances, a vehicle must be able to position itself with only minimal contact from any external systems (i.e. GPS). Therefore, the AUV's Navigational System is a crucial subsystem required for the mainstream utilization of AUVs. However a Navigational Suite must not only be accurate, but to be practical, it must be small in size, a low power drain on the vehicle, and low cost.

AUV surface navigation can be accomplished with the use of the Differential Global Positioning System (DGPS), as it is with normal surface vessels. DGPS provides a readily available, inexpensive means for positioning which makes it very suitable for the AUV. However, the high frequency signal, which transmits information from the GPS satellites to the AUV, cannot travel through the water. Therefore, an additional method of navigation needs to be incorporated into the system to accommodate underwater navigation.

Manned submersibles in deep water currently use inertial navigation while submerged. However, high accuracy Inertial Navigation Systems (INS) are not practical

for many AUVs due to their large cost and size. [Ref. 1] Therefore, while the vehicle is submerged, it must obtain its position by fusing data from additional internal sensor measurements (i.e. speed, and heading). The increasing cost of those “additional” sensors is dependent on the accuracy they produce. By limiting the sensors with a “low cost” objective, the system’s ability to effectively provide the AUV’s position becomes limited by the amount of bias error, and deviation produced by cheaper components. Commercially, heading sensors could range from a Ring Laser Gyro to a magnetic compass. Similarly for speed, velocity sensors vary from an Acoustic Doppler Sonar to a simple pitot tube. Accurate Doppler velocity sensors are primarily in demand because they measure the vehicle’s speed relative to the ocean floor, and not the water column itself. Measurements that are relative to the water are susceptible to error from currents and particulate matter. [Ref. 2] Additionally, “doppler lock” on bottom is assured for shallow water operations.

B. CURRENT NAVIGATION METHODS

Several methods are currently employed for the navigation of underwater vehicles, the most basic of which is dead reckoning. Dead reckoning determines the AUV’s position by calculating the distance traveled from its measured speed and time interval, and applying it in the direction of a heading measurement. The existing errors present in the velocity measurements grow during subsurface periods between DGPS updates, because the velocity, with an error bias, must be integrated to determine position. That integration causes the existing error to become larger.

A second method of navigation uses an external "base-line" constructed from signal beacons placed in the water. These beacons broadcast a range signal from a known position to allow the AUV to determine its own position. However these buoys require moderate to high levels of support to install and maintain, depending on the local environment. Additional support for this method can consume excess time and money. An ideal system uses measurement from internal sensors to determine its position underwater.

Using a 1°/hr error, Ring Laser Gyro, Inertial Motion Unit (IMU), (such as *Honeywell's* 'HG 1700' system, c. \$12,000), together with an 1% speed error, "ground locked", Acoustic Doppler Sonar (such as *RDI's* 'Navigator II', c. \$25,000), leads to an expected drift error of 1% of distance traveled for 1hr of travel time. In other words, to limit the raw error to 2m, with a speed of 1m/s, a position correction fix must be taken every 600-1000m. While this argument is not precise, it indicates that, without the use of acoustic beacons, DGPS fixes must be obtained to bound the error, and therefore a combined "IMU/Acoustic Doppler/DGPS" system is needed. Its sensor's measurements could be integrated underwater, and cross-referenced above water, to accurately estimate the AUV's position at all times.

A Kalman filter is used as a recursive technique for integrating sensor data, velocity, heading, and DGPS position when it is available. [Ref. 3]

"The Kalman filter performs three main functions, it optimally integrates data from multiple sensors, incorporates models of the sensors error characteristics, and recursively processes the measurements from the sensors that are available". [Ref. 2] As a byproduct of the algorithms that compose it, the filter "learns" biases associated with

the heading and heading rate sensors. It is its ability to compensate for those learned biases, in “Real-Time”, which makes the filter a valuable component for an AUV’s Navigational Suite.

C. THESIS SCOPE

This thesis continues the work of several previous Masters students who researched the design of a DGPS system for the Naval Postgraduate School’s (NPS) AUV program, and developed a Kalman filter program for use in AUVs. [Ref. 5; Ref. 4] The objectives of this report are to properly configure the designed DGPS, implement it into the new NPS AUV, the ARIES (Acoustic Reconnaissance Interactive Exploratory Server), and experimentally evaluate it in an open-water environment. Secondly, adapt the previously developed Kalman Filter software for use in the ARIES. And finally, operate that adapted program in conjunction with the DGPS, in the same open water environment, and obtain positioning results with near sub-meter accuracy.

The thesis is organized in the following manner; Chapter I is an introductory chapter which provides background information for the system evaluation, and a description of the main objectives for the report. Chapter II provides foundation information about DGPS, and the key points addressed during the configuration of a system used in an AUV. Chapter III details the Navigational Suite, how it works, and its components. Chapter IV provides the basic theory of Extended Kalman Filtering (EKF), and introduces the concept of asynchronous data collection, which needed to be specifically considered during the filter’s “real-time” adaptation. Chapter V discusses the experimental results of the Navigation Suite’s evaluation tests. Finally, Chapter VI

presents the conclusions of those results, and gives some recommendations for further research.

THIS PAGE INTENTIONALLY LEFT BLANK

II. GLOBAL POSITIONING SYSTEM

A. INTRODUCTION

The United States Global Positioning System (GPS) was created by the Department of Defense (DOD) to be a worldwide resource for navigation. GPS satellites allow for radio navigation by transmitting range and time information to receivers, such as in the ARIES vehicle, which use this information to determine the vehicle's velocity, position, and time. By applying publicly broadcast differential corrections to these coded radio signals, a receiver can increase the accuracy of its position solution to within 5m. Naturally, since radio waves do not penetrate through saltwater by many wavelengths, and since the wavelengths of the primary GPS signal is only 7.48in, GPS positioning is essentially confined to the above water region of the globe. [Ref. 6]

1. GPS

Dubbed the Navstar system, GPS depends on a constellation of 24 active and 3 spare satellites, which orbit the Earth at a height of 20,200km. Each satellite orbits the Earth in one of six orbital planes. This allows for 5 to 9 satellite to be visible from any point on the earth at any one time. [Ref. 7]

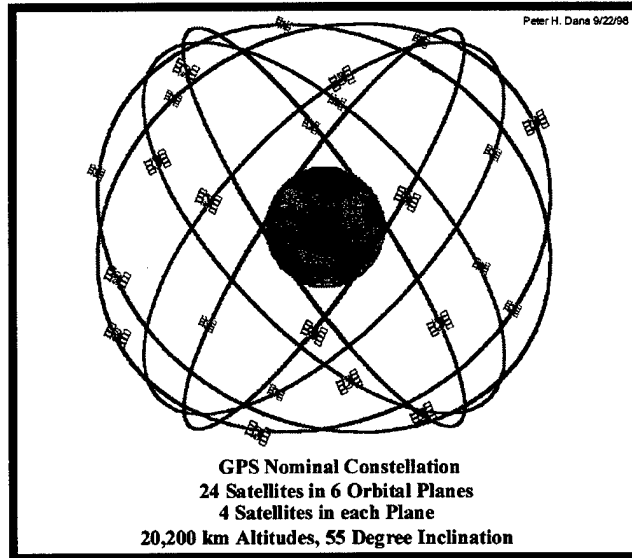

Figure 2.1: GPS Constellation. [Ref. 8]

GPS satellites broadcast on two separate radio frequencies, 'L1' (1575MHz) called Coarse Acquisition Code (C/A Code), for general public Stand Positioning Service (SPS) use, and 'L2' (1227MHz) which measures ionospheric signal delay, for Military Precise Positioning Service (PPS). The L1 code is intentionally degraded so that the global public does not have access to precise positioning data, but still allows for an average position accuracy of within 100m on the horizontal plane. [Ref. 9]

A GPS satellite uses the L1 frequency to provide a receiver with the encoded distance measurement between the receiver and that particular satellite, referred to as 'Pseudorange', at a specific time. A receiver must have a Pseudorange from at least 3 satellites to determine a 2-dimensional position, and at least 4 satellites for a 3-dimensional position, using spherical triangulation. The fourth satellite acts as a crosscheck of the calculation. If the receiver detects more than 4 satellites, it will use the satellites with the 4 best elevation angles for triangulation.

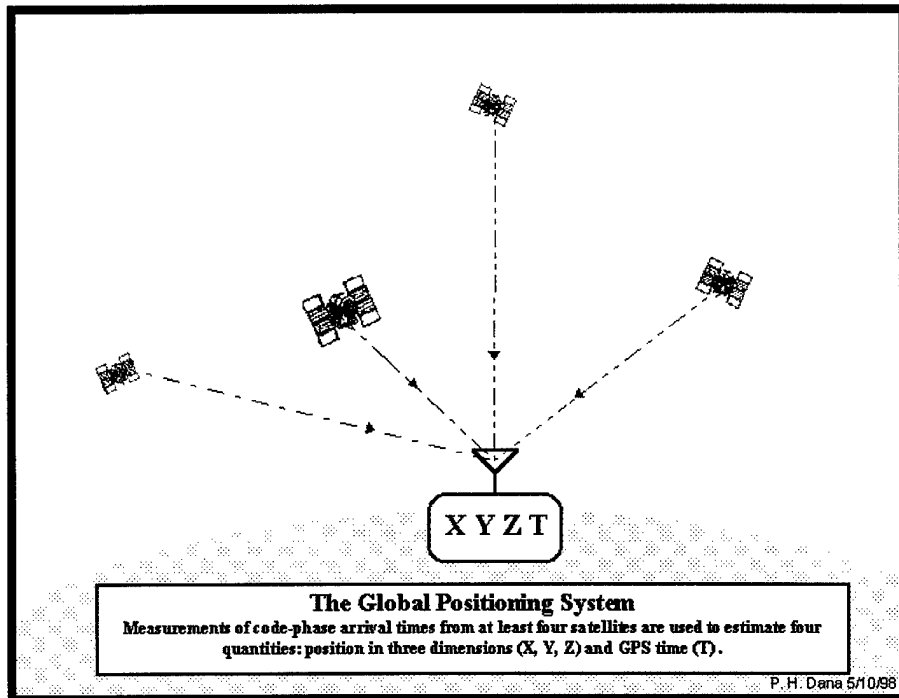

Figure 2.2: GPS Satellite Triangulation. [Ref. 8]

The natural and induced degradation of Pseudorange measurements are what determine the system's average 100m horizontal, 156m vertical, and 340nsec time accuracy. [Ref. 8] Ranging errors are increased by differences in range vectors between the satellites and receivers. When these range vectors are used to find a position fix, the volume of the 3-dimensional shape described, is inversely proportional to an amount called the Geometric Dilution of Precision (GDOP).

“DOP is a mathematical representation of the quality of GPS data being received from satellites.” [Ref. 10] DOP or GDOP is often broken down into the quantities HDOP (horizontal), VDOP (vertical), PDOP (positional or spherical), and TDOP (time). Poor GDOP is represented by a large value. This means that the geometric volume is rather small, and the satellites have inherently poor resolution of the fix. Good GDOP is a smaller number reflecting a larger geometric volume, and good triangulation. Poor

GDOP combined with signal degradation can cause a GPS accuracy that is much worse than the 100m. [Ref. 10] Qualitatively, DOP is a statistical probability, between 1 and 100, of the amount of error which is likely to be present in relation to the satellite data used to determine a geographic fix.

“A DOP of 1 indicates an optimum satellite constellation, and high quality data.”
For data to be useable, it is generally associated with a PDOP of between 1 and 8. [Ref. 10]

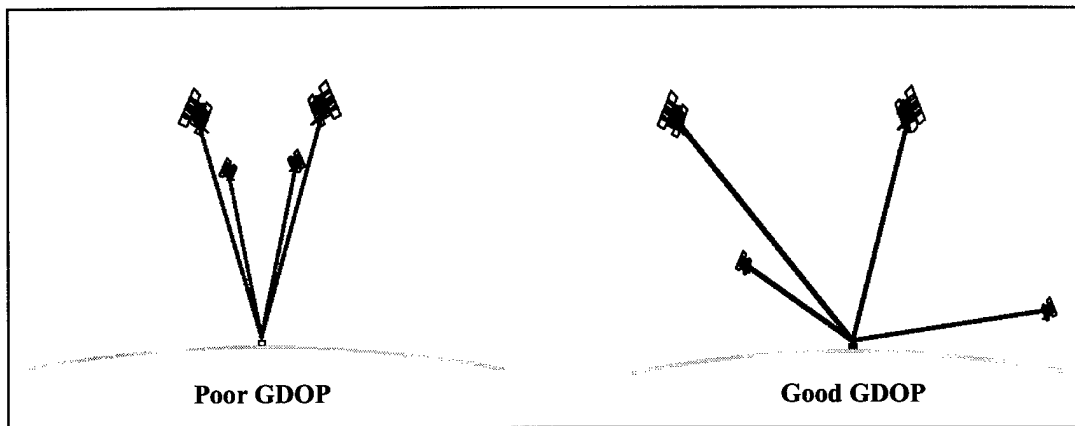

Figure 2.3: Geometric Dilution of Precision (GDOP). [Ref. 8]

GPS signal degradation is due the effects of intentional government degradation called Selective Availability (SA), and other unintentional errors from atmospheric to computer sources. The most common sources of individual error are:

- Selective Availability
- Ionosphere
- Troposphere
- Satellite Clock
- Code Measurement

- Receiver Clock
- Multipath
- Satellite Ephemerides

All of these errors are not present all of the time. However, because they do severely limit the receiver's positioning accuracy, most receivers, including the ARIES vehicle's receiver, use an additional second measurement.

Phase measurements are carried out, by the receiver, on the actual encoded signal itself. The receiver measures the signal's phase angle by observing the number of wavelengths and partial wavelengths that are met by the receiver's antennae over some period of time. If the receiver knows the exact phase angle of the satellite signal, it can correct the range measurement to millimeter accuracy. [Ref. 9] However, a single receiver is not capable of determining the exact signal phase angle.

Phase angle measurements also contain errors due to the error sources previously mentioned. A single receiver, because of these errors, cannot accurately determine the number of wavelengths between the satellite and itself. This means that the accuracy obtainable by single-receiver GPS alone, is unsatisfactory for the uses of maritime navigation.

Therefore in 1987, the U. S. Coast Guard (USCG) began work on a method for increasing GPS accuracy to bring it within the limits set forth in Federal Radionavigation Plan (FRP), positioning within 10m. [Ref. 7] This led to the concept of broadcasting differential corrections from a permanent reference station.

2. Differential GPS

Differential GPS (DGPS) involves the use of a reference station with known exact coordinates. The reference station receives encoded signals from the individual GPS satellites in view from its position. It compares the pseudorange measurement from each satellite to the value of its known position, and derives a pseudorange correction (PRC) for each satellite's signal independently. These corrections are then broadcast, in a standard format by both public and private parties, for the use of GPS receivers in the area.

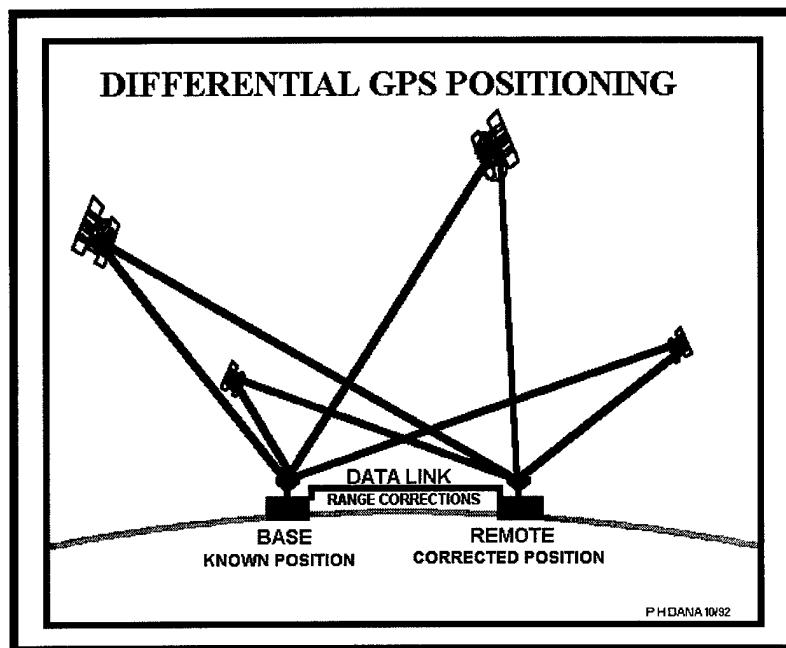

Figure 2.4: DGPS Position Correction. [Ref. 8]

The U. S. Coast Guard currently provides an adequate allotment of operational reference stations to provide differential coverage to all U. S. coastlines, as well as other major U.S. waterways. These reference stations broadcast differential corrections for the satellites within their view in a format constructed by the Radio Technical Commission

for Maritime Services Special Committee 104, and designated RTCM SC-104. Not all GPS receivers can make use of these differential corrections.

An adequately equipped receiver contains the software that makes it capable of applying the correction provided for each satellite it is using, to determine a more accurate position. A more detailed description of this software will be made later, with regards to the ARIES own GPS receiver. In addition, such a remote receiver must not only have a connection with an antennae to receive satellite signals, but also an antennae to receive the corrections broadcast from a nearby reference station.

Differential corrections are most useful for a remote receiver that is close to the reference station because they are only corrective of the first 5 errors previously listed. These errors are only common to both a reference and remote station if their geographic position is relatively close, within 100km, because they are largely atmospheric, or refer to the same satellites. [Ref. 9] The other 2 errors, multipath and receiver noise cannot be corrected, but may instead be reduced by a technique known as 'Carrier Phase Smoothing', included in the software of most modern receivers.

When the 7 major errors mentioned are accounted for, by smoothing or differential corrections, the system positioning accuracy is on average of 1-5m. [Ref. 9] Further use of Carrier Phase Corrections reduces the error to sub-meter precision.

B. ARIES DGPS SYSTEM

The ARIES DGPS must be highly effective and well suited for the vehicle. Specifically, the system should use differential corrections, have as little antenna drag as possible, and be easily adjustable for different environmental conditions. Each of these

objectives is met by addressing them in order of importance. It is most important to ensure accurate position, therefore, it is most important to ensure the vehicle can receive a differential signal. Obtaining differential corrections require a source for those corrections, and a beacon that picks up that signal.

1. System Constraints

The Monterey Bay Aquarium Institute (MBARI) broadcasts a differential signal at 466.76MHz. It's perpetuated from a Mount Toro repeater and covers the entire Bay area. [Ref. 5] However this signal suffers frequent periods of outages, which make it unsuitable for the continuous navigation of an AUV, powered by time-limited batteries.

As previously mentioned, the USCG offers publicly broadcast differential corrections to all major U. S. coastlines and waterways. The Monterey Bay source of these corrections is located north of Santa-Cruz at Pigeon Point, and broadcasts its signal at 287kHz. The other broadcast stations broadcast on a frequency range of 283.5 – 325kHz. [Ref. 5]

This introduces the first system constraint. Differential signal beacons are manufactured to receive a particular signal frequency. This would be fine if the ARIES vehicle stayed within the broadcast range of the Pigeon Point station. However, NPS Center for AUV Research currently participates in various exercises across the globe. Some of these exercises include annual participation in 'AUVfest' located offshore of Gulfport, MS., and a planned cooperative exercise in the Azores, with the University of Lisbon. Obtaining beacons constructed to receive signals in each of these areas, as well as removing and installing these beacons with each mission, is neither cost effective or

practical. A system is needed which can be altered to accept a range of frequencies. A second system constraint centers about the ARIES antennae.

The vehicle requires an antenna for the communication of the command/control signal from a remote base-station. This allows for the operators to view files collected by the AUV in real-time, as well as the communication of new commands or missions to the vehicle. A second antenna will be required by the GPS receiver to collect satellite data and establish a position fix. Finally, because the differential corrections signal's frequency (kHz) is so much lower than the satellite's C/A frequency (MHz), the differential signal requires a much larger antennae.

These varying system constraints require separate antennae, which will in turn increase vehicle drag to an unacceptable level. A solution must be created which can reduce the size or number of objects attached to the outside of the vehicle hull.

2. System Solution

The problem of varying geographically varying signal frequency was solved with the use of a differential receiver. This receiver is capable of varying the signal it accepts, based on the signal being picked up by the beacon. Once the corrections are accepted, they are passed along to the GPS receiver, which uses them with to correct the satellite data it collects, and determines an accurate fix. However, the addition of a differential receiver requires more space, which is limited within the AUV hull. This brings about discussion of a solution to the drag problem due to too many antennae.

The current vehicle base-station was used to locate the differential receiver and beacon. This allows for the differential beacon to be sized however necessary to receive

any frequency differential signal, and not hinder the fluid flow over the vehicle. These corrections will be sent to the vehicle over a 900Hz radio signal through a radio modem, and received through the command/control aerial by a splitter connection to a second radio modem. The splitter, called a "Multiplexer", makes it possible to receive the corrections for the radio modem, as well as, the command signals for the tactical computer, on the same antenna. More detailed descriptions of the vehicle's hardware is presented in Chapter 3.

III. ARIES NAVIGATIONAL SUITE

A. INTRODUCTION

The ARIES hardware was selected to meet the three basic objectives of size, accuracy, and cost. The component's size is important because it effects the size of the drag forces, which act on the vehicle during underwater transit. If a sensor is externally mounted to the vehicle, it adds a drag force with the addition of it own profile. If the component is an internal component, it adds weight to the vehicle, which must be compensated for by increasing the size of the vehicles wetted-surface area to maintain proper ballast, which will again effect the drag. The overall accuracy of the Suite is dependent upon the sum of the accuracy of individual component. Therefore the selection of the components used in the ARIES AUV was based on a balance between their cost, and the degree of accuracy they provide. Their combined accuracy is expected to produce a navigational error of less than one meter in the final operating configuration.

1. Navigational Suite Overview

The ARIES navigational suite only represents a part of ARIES entire computer architecture. The following diagram of the vehicle's internal systems shows the interaction of the navigational system (green) with regards to all other components.

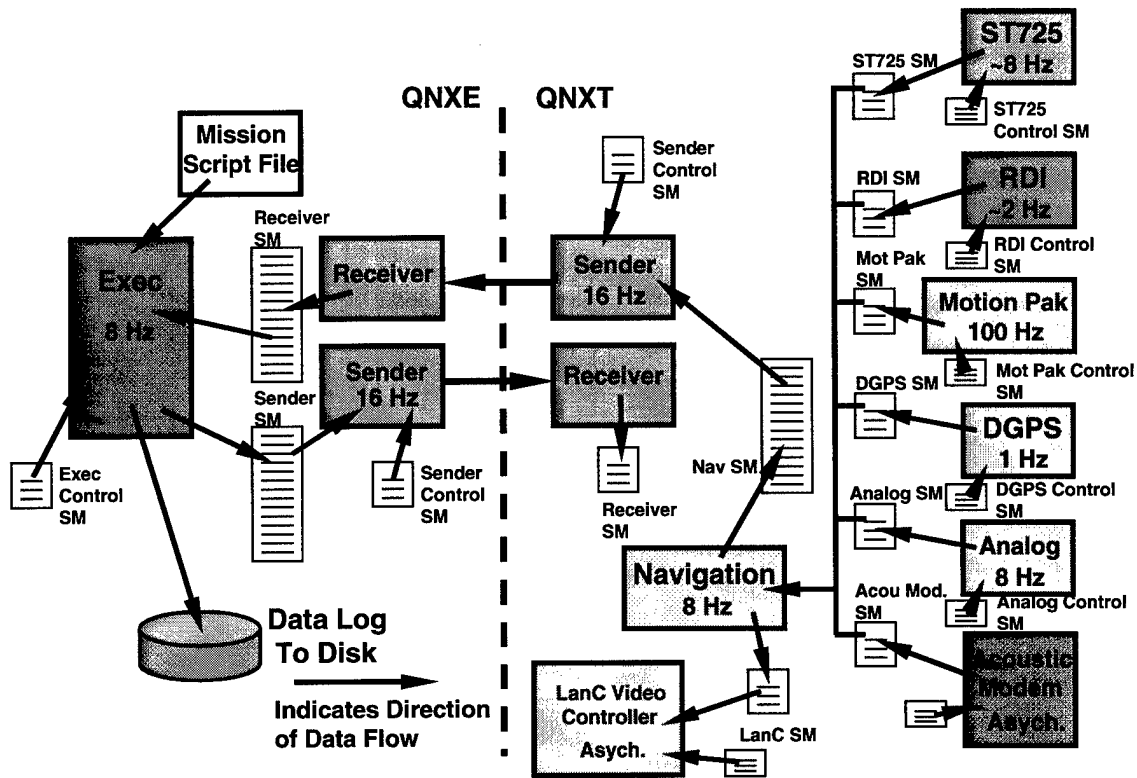

Figure 3.1: ARIES AUV Computer Architecture. [Ref. 11]

The Navigational Suite is designed to provide the ARIES CPU with a position based on information from 4 sensors. In addition to the DGPS system, a bottom-mounted Doppler Sonar Velocity Log, internally mounted Inertial Motion Unit (IMU), and internally mounted depth cell, also provide basic information for the use in constructing an accurate map of the vehicle's path by the vehicles computers. The interaction of these navigational components, within the navigation suite, can be viewed in the diagram below.

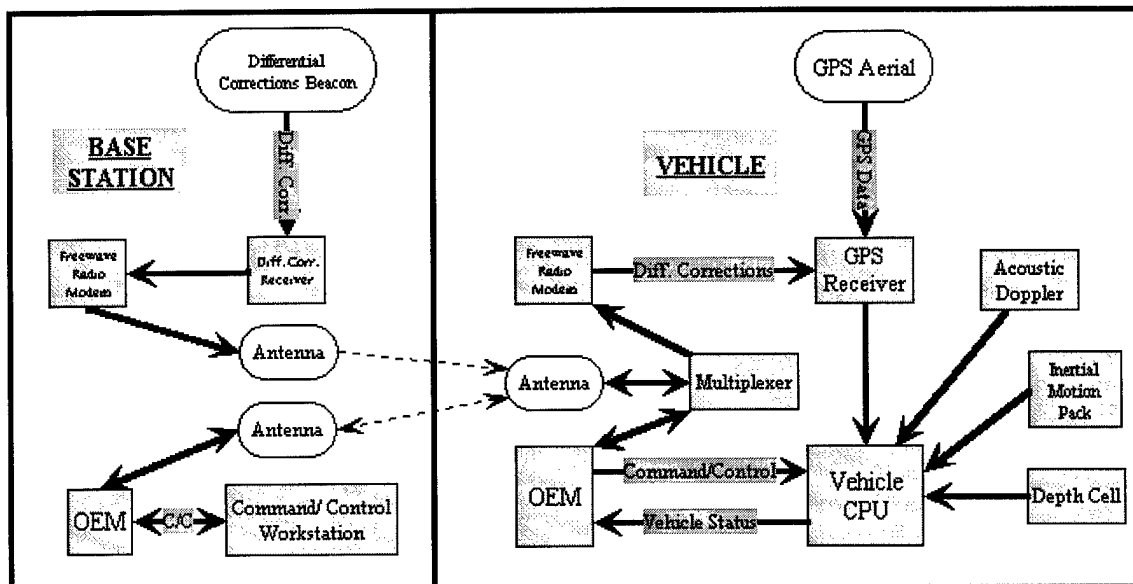

Figure 3.2: ARIES Navigation Suite Diagram.

B. SYSTEM COMPONENTS

The complete Navigational Suite consists of the following components:

- GPS Receiver and Power Supply
- Differential Corrections Receiver and Power Supply
- GPS Antennae
- Differential Beacon
- 2 Radio Modems and Power Supply
- Base-station Radio Antennae
- Command/Control Antennae
- Doppler Sonar Velocity Log
- Inertial Motion Unit (IMU)
- Depth Cell
- ARIES Navigational Filter

To better understand these how these components interact, it is important to know the specifics on each piece of hardware and software used within the suite.

1. Base-Station Hardware

As mentioned earlier in this study, there are two separate parts of the DGPS. The base-station components consist of the differential receiver, the differential beacon, and the radio modem. The differential receiver and beacon are connected to the radio modem using an RS 232 serial port connection. Both the receiver and modem can be internally configured by connecting them, using the same serial ports, to a computer with the appropriate software. This software will be discussed following the DGPS hardware section of this study.

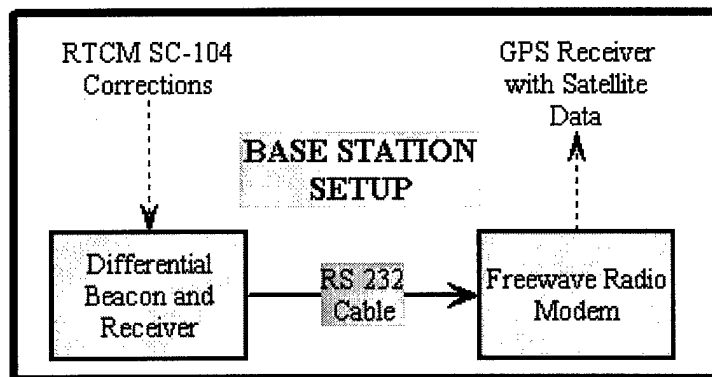

Figure 3.3: DGPS Base-Station Configuration.

a. The Differential Receiver and Beacon

The differential receiver and beacon used with the base-station are products of *Communication System International (CSI)*, and called the 'ABX-3' receiver, and 'MBL-3' magnetic field antenna. The ABX-3 receiver requires a 9-40V DC external power source, and the MBL-3 receiver's power from its cable connection to the ABX-3.

Both products, as seen below, operate with specific features, which make them valuable for the ARIES project.



Figure 3.4: Differential Receiver and Beacon [Ref. 5].

The main feature of the ABX-3 receiver is its ability to work under a manual tuning or automatic tuning mode. The manual tuning mode is activated using a standard National Marine Electronics Association (NMEA) 0183 format for commands and queries. This format can be seen in Appendix A as it appears in Ref. 5. The ABX-3 can be automatically tuned to any frequency within the USCG frequency range (283.5 – 350kHz), using an option called Automatic Beacon Search (ABS) [Ref. 9]

The ABS works by using two separate operating channels. Each channel searches for a separate broadcast frequency in the RTCM SC-104 format. Once a channel locates a signal, it locks onto that signal, evident by a green light on the front of the ABX-3, and relays those corrections over the RS 232 cable. Meanwhile if the other channel locates a frequency, which exhibits a signal strength (SS) 2dB greater than the

current locked signal, the receiver will automatically switch to this signal, lock onto it, and begin relaying those corrections to the serial cable. [Ref. 5] This is ideal for a situation in which the base-station may be mobile, and drifting between two USCG broadcast areas of different signal frequencies.

The main feature of the MBL-3 beacon is its use of an H-field type loop antenna. The H-field loop is less susceptible to noise than a tradition antenna, does not require a ground connection, and takes up less physical space than a traditional antenna. [Ref. 9]

b. The Radio Modem

The radio modem used to connect the base-station to the vehicle is a product of *Freewave Technologies Inc.*, and known simply as the 'Freewave Modem.' This modem always works with an identical modem, can be configured using software, and requires a 12 or 24V DC external power source. For its use with the ARIES DGPS, the standard master (base-station modem) to slave (AUV modem) configuration has been set. The modems operate at an alterable baud rate of 9600bps. The modems are also configured for specific channels of communication, once any point to point mode (ex. Master to Slave) is selected. The Freewave modem can be seen in Figure 3.5 below.

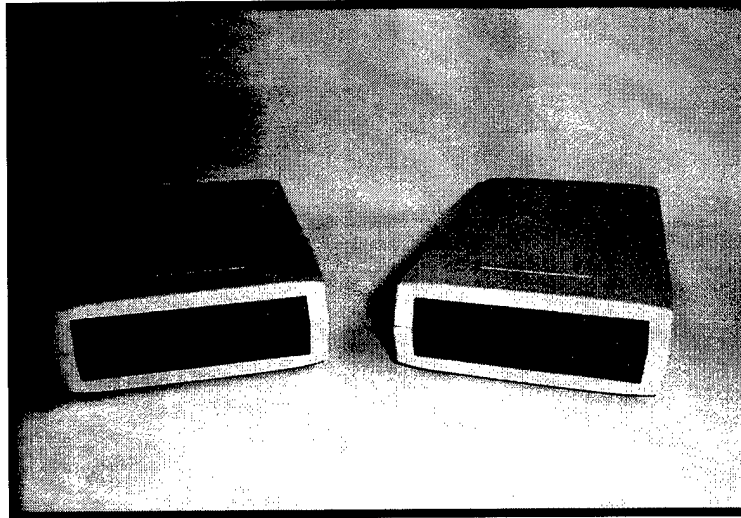

Figure 3.5: A Freewave Radio Modem Pair. [Ref. 5]

2. AUV Hardware

The AUV internal navigation components consists of the GPS receiver, the slave radio modem, the GPS aerial, the command/control antenna, a slave Freewave modem connected to a splitter from the antenna, the Acoustic Doppler, IMU, and depth cell. The splitter connection, called a “Muiltplexer,” differentiates between the combined differential corrections and command/control signals received by the two-way command/control antenna. The AUV’s internal batteries power all of the internal components, which require a power DC source. A 60V DC bus carries DC power to the internal compartments of the vehicle, while DC-DC converters are used to provide 5, 12, 24, and 48V DC power sources for subsystems.

a. The GPS Receiver and Aerial

The DGPS portion on this end of the modem connection receive the corrections and send them to the GPS receiver via an RS 232 serial cable, as seen below in Figure 3.6.

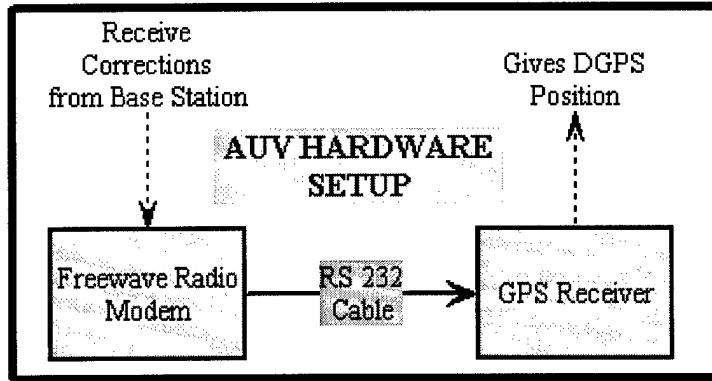

Figure 3.6: DGPS AUV Configuration.

The GPS receiver is an *Ashtech* 'G-12' model. It is connected to the GPS aerial by a direct cable, which passes through a sealed hull penetration. This is necessary to reduce the number of connections between the aerial and the receiver, thus reducing any possible problem which may occur due to impedance mismatches and/or lack of signal strength from the satellites.

The G-12 is capable of tracking up to 12 satellites at one time, however it only uses the best 4 signals to calculate a fix. The number of satellites being tracked by the receiver can be readily observed by counting the green flashes given off between red flashes on its external LED. When the receiver is tracking at least 4 satellites and has a PDOP less than 4, it generally returns a position with an error less than 16m. A complete readout of the satellite information can be viewed by connecting the G-12 to a computer via a serial connection, and reading the positioning information with the custom software provided, which is described later. [Ref. 12] The G-12 can be seen below in Figure 3.7.

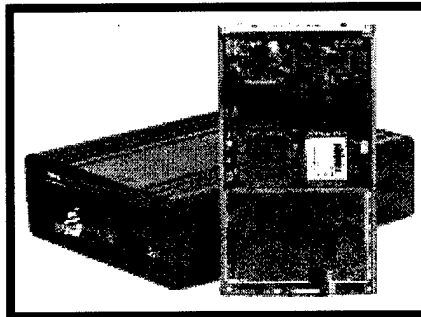

Figure 3.7: Ashtech 'G-12' GPS Receiver. [Ref. 12]

The GPS aerial is a *MicroPulse* model '18800', internally amplified, 26dB aerial. It needs be mounted only 6" above the water surface to receive satellite data, and works best when it is mounted on top of a 2x2in metal ground plate. Because the aerial is itself only 1.5 x 1.5 x 0.5in, it creates little extra drag for the vehicle. It is constructed of a polymer resin and sealed to prevent water damage. [Ref. 13] The 18800 can be seen in Figure 3.8 below, as it is mounted on the ARIES. The picture shows the aerial mounted to a ground plate (white) on top of the rear rudder guard (white). The "aerial to G-12" cable passes through a hull penetration immediately behind the rudder (blue).

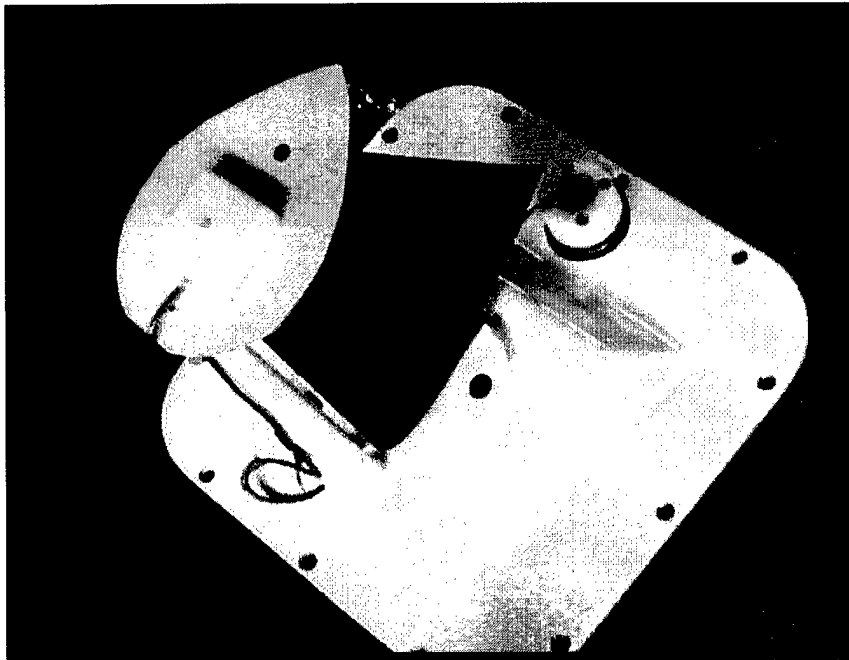

Figure 3.8: Mounted GPS Aerial and Cable Hull Penetration.

b. Command/Control Antenna and Multiplexer

The command/control antenna and combination/splitter connection, referred to as a “Multiplexer”, are also both new to additions for the ARIES DGPS. The antenna currently used on the ARIES is a 12” long, 0.5” diameter, rigid antenna designed and manufactured by *Webb Research Institute*. This antenna receives signals from both the command/control and differential corrections radio modems. It splits the two signals using an internally mounted 75ohm, signal splitter, which then sends each signal to their respective slave modems located in the AUV. [Ref. 6] The antenna is capable of transmitting and receiving, and is the vehicle’s primary method of wireless communication. It is mounted on top of the ARIES, 2/3 of the way along the body from the front, and shown in Figure 3.9.

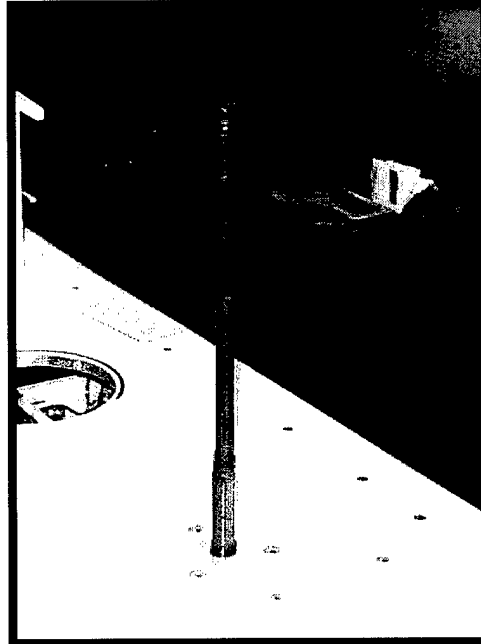

Figure 3.9: Two-way Command/Control and Differential Corrections Antenna.

c. Sonar Doppler Velocity Log

The Sonar Doppler Velocity Log is an “Workhorse Navigator” 1200 kHz model, manufactured by *RD Instruments*. It measures the vehicles forward and lateral speed referenced to the bottom or water column, as well as the vehicle’s altitude, pitch, roll, and heading. The device uses 4 convex transducers aimed 30 degrees from vertical to send out active pings at a frequency of 2 Hz. The Doppler is rated for a depth of 2000m and is powered by a 24V DC source from within the AUV. The range for ground lock for this unit is 30m, although this value could be increased with the use of a lower frequency ping. For instance, the 600kHz unit has a maximum altitude of 90m. [Ref. 14] It is shown in Figure 3.10 below.



Figure 3.10: RDI Workhorse Navigator Doppler Velocity Log. [Ref. 14]

d. IMU

The Inertial Motion Unit is manufactured by *Systron Donner*, and internally mounted on the AUV. The 'IMU' is a "solid-state" 6 degree of freedom inertial sensor which measures angular rates and linear accelerations with 3 quartz angular rate sensors, and 3 linear servo accelerometers. It is powered by 15V DC from within the AUV, and produces analog measurements. A separate process reads digitized IMU data with a 16-bit A/D at 100Hz, and sub-samples that data for use at the control rate of 8Hz. [Ref. 15] It is shown in Figure 3.11.

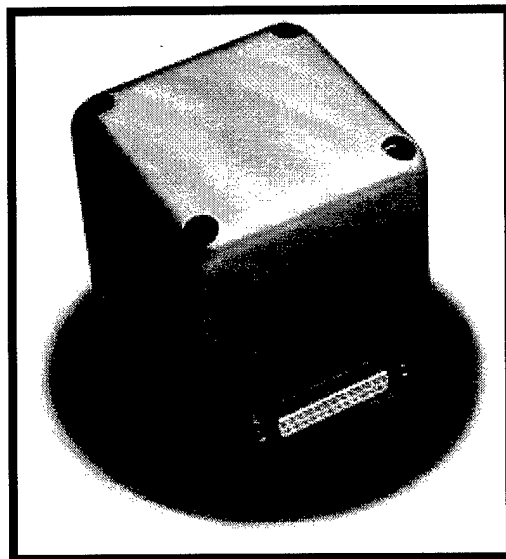

Figure 3.11: Systron Donner IMU. [Ref. 15]

e. Depth Cell

The depth cell used in the ARIES is a pressure transducer/transmitter manufactured by *PSI Tronix* and is model 'PWC'. It has a depth range of 0-15psi absolute, and operates by measuring the strain on an internal diaphragm with Silicon strain gages. [Ref. 16] It is powered by the vehicle's batteries, and is shown in Figure 3.12.

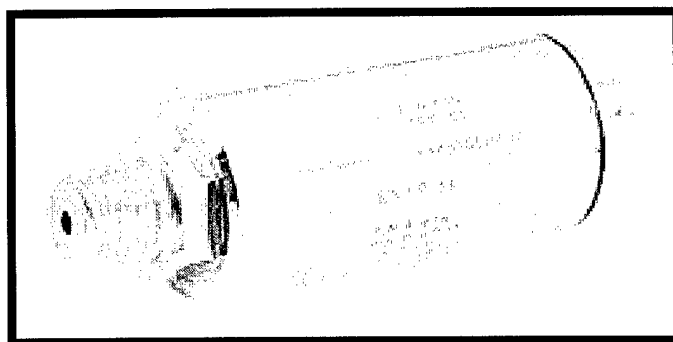

Figure 3.12: PSI Tronix PWC Pressure Transducer/Transmitter. [Ref. 16]

3. System Software

The ARIES navigational suite operates with several pieces of equipment that need to be manually configured, as previously mentioned, on a computer. These components, namely the ABX-3, the Freewave Modems, and the G-12, are connected to a computer through the computer's COM-1 port with a serial cable. Once connected, each component can be configured if its output is read with the appropriate software, set to the appropriate settings. There are two main types of software used to read these outputs, one for the ABX-3 and radio modems, and one for the G-12.

a. Procomm Plus (Radio Modem)

'Procomm Plus' is a program offered by *Quaterdeck*. It can be configured for terminal emulation of 36 different terminals, and file transfer with 11 different protocols. It is used to display the simple terminal emulation that comes from the modems setup menu. Procomm Plus runs on Windows platforms and may be customized to suite the needs of the user. The software was specifically used with the hardware to set the modem operating mode and the data transfer baud rate. [Ref. 17]

b. Command Message Software (G-12 and ABX-3)

This software is a program that relays commands and queries to the G-12 and ABX-3 through a serial connection. It also allows the user to view the current configuration of the receiver, and change any options that you choose. That configuration change may be as simple as to reset the time between output fixes, the communication baud rate, or as complex as changing the setup to recognize the

differential corrections coming from a remote source, as it is with the ARIES. A list of example software commands and queries frequently used in the ARIES AUV in relation to the G-12 and ABX-3, and their meanings, may be found below. [Ref. 12]

- **\$PASHS,NME,POS,A,ON** - Enables a display of the NMEA position message on port A (G-12).
- **\$PASHS,RTC,REM,B,ON** – Sets Port B receiver to operate as the differential remote station, and enables it (ABX-3).
- **\$PASHS,NME,SAT,A,ON** – Enables a display of the NMEA satellite information message on port A (G-12).
- **\$PASHQ,PAR,x (where x is A or B)** – Queries the current settings of the specified port (G-12 and ABX-3).
- **\$PASHQ,RTC,B** – Queries the current differential settings of port B (ABX-3).
- **\$PASHS,SAV,x (where x is Y or N)** – Enables or disables automatic saving of set parameters in the battery backed up memory (G-12 and ABX-3).
- **\$PASHQ,SAT,A** – Queries the status of the SV's currently locked by the receiver on port A (G-12).

THIS PAGE INTENTIONALLY LEFT BLANK

IV. KALMAN FILTERING

A. INTRODUCTION

A Kalman filter is a programmed process that provides an optimal estimate of state variables with a least squares error, given a set of measurement data and a model. This estimate is based on measurements retrieved from sensors, information about those sensors, and prior information about the system. [Ref. 18] Key references for the theoretical development of Kalman Filters are Kalman, 1960, Gelb, 1989, and Bar-Shalom, 1993. The filter's application to low cost AUV navigation has been outlined in Healey, An, and Marco, 1998.

B. KALMAN FILTER THEORY

Although Kalman filters can be discrete or continuous, the ARIES vehicle uses a digital computer, which is only capable of discrete time interval computation. However, the model represented by the vehicle dynamics, is a continuous state model, therefore a discrete time, continuous state filter is needed for vehicle navigation. To accomplish this first requires an understanding of how a discrete filter works.

1. Discrete Kalman Algorithms

In the ARIES AUV data does not continuously flow from the sensors. Instead, each sensor has a specified nominal measurement rate, at which it delivers that measurement to the navigation process.

Five major algorithms for Kalman filters represent the discrete time measurement and the recursive estimation of both the model state, and its error covariance. In a multi-

variable system, such as the ARIES navigational filter, the system and measurement models are represented by the equations:

$$\begin{aligned} \mathbf{x}_{k+1} &= \boldsymbol{\varphi} \mathbf{x}_k + \mathbf{q}_k \\ \mathbf{y}_k &= \mathbf{C} \mathbf{x}_k + \mathbf{v}_k \end{aligned} \quad (1)$$

In these equations, k is the time step, \mathbf{x} is the system state and $\mathbf{x} \in \mathfrak{R}^{8 \times 1}$, \mathbf{y} is the measurement and $\mathbf{y} \in \mathfrak{R}^{6 \times 1}$, \mathbf{C} is the matrix relating output to the state variable, and \mathbf{q} and \mathbf{v} are assumed to be gaussian white noise, with zero means and designated covariance. $\boldsymbol{\varphi}$ is the state transition matrix, which has its characteristics from the continuous state model dynamics matrix, \mathbf{A} , for this system ($\boldsymbol{\varphi} = e^{\mathbf{A}T}$, where T is the update time). [Ref. 19]

To begin the recursive process of running the algorithms for each time step, each of the variables used in these algorithms must be initialized to some value. When the filter is started for the first time, this value will be determined by the programmer, each successive iteration of the algorithm will define the variables as the last estimated value.

The first major algorithm, equation (2) shows the propagation of the state by using the model (1) expressed as a mean value.

$$\hat{\mathbf{x}}_{k+1/k} = \boldsymbol{\varphi} \hat{\mathbf{x}}_{k/k}; \quad (2)$$

This equation shows $\hat{\mathbf{x}}_{k+1/k}$, which is the estimated state at time step $k+1$, based on the estimated state at time step k . The filter actually estimates the state twice using the algorithm in a prediction/correction mode. This first estimate is based solely from the state model. The second estimate will be based on the fusion of the first estimate and the data from the measurement.

The second major algorithm, equation (3), estimates the error covariance for the $k+1$ time step, based on the error covariance from time step k , and the additive designated system uncertainty matrix Q , derived from the system noise, q .

$$P_{k+1/k} = \phi P_{k/k} \phi^T + Q; \quad (3)$$

The error covariance will also be estimated twice during the complete filter loop. The second estimate will be made from the correction estimate of the state variables. Before those estimates can be made, however, the filter gain must be determined, which will minimize $P_{k+1/k+1}$.

The filter gain is calculated in the third major algorithm, equation (4). This gain is determined based on the newly estimated error covariance as it relates to the output variables, as well as the designated measurement channel noise.

$$G = P_{k+1/k} C^T (C P_{k+1/k} C^T + R)^{-1}; \quad (4)$$

In this equation G is the filter gain, and R is the matrix of measurement channel designated noise covariance. This gain is used for the correction of the state variables.

Equation (5) below shows the next major algorithm. Here the state variables are estimated, by adding the prediction with a difference between the new measurement and the value predicted by first estimate, and weighted by the filter gain.

$$\hat{x}_{k+1/k+1} = \hat{x}_{k+1/k} + G(y_{k+1} - C\hat{x}_{k+1/k}); \quad (5)$$

In this equation, $\hat{x}_{k+1/k+1}$ is the correction estimate, at the time step $k+1$, based on the measurement taken at time $k+1$.

$$P_{k+1/k+1} = P_{k+1/k} - G C P_{k+1/k}; \quad (6)$$

In equation (6), the final major algorithm, the second error estimate is determined for the $k+1$ time step. $P_{k+1/k+1}$ is always less than $P_{k+1/k}$ since $GCP_{k+1/k}$ is a positive value. [Ref. 19]

After the filter has determined the corrected estimates of both error covariance and the state variables, it will then go back to equation (1) and (2) and define an initial estimate for the next time step, and continue. Each time the filter will provide state estimates with the minimal (optimal) error covariance, and continually reducing covariance estimates. This system works well for specific discrete time data. But as previously mentioned, the ARIES control systems are modeled after a continuous state model. Therefore understanding the difference between the two models is crucial to understanding the ARIES Navigation Filter.

2. Continuous State Model

In a continuous time model, both “the system model and the output equation are nonlinear.” [Ref. 3]

$$\begin{aligned}\dot{\mathbf{x}}(t) &= \mathbf{f}(\mathbf{x}(t)) + \mathbf{q}(t); \\ \mathbf{y}(t) &= \mathbf{h}(\mathbf{x}(t)) + \mathbf{v}(t); \end{aligned} \tag{7}$$

$\mathbf{x}(t) \in \mathfrak{R}^{8 \times 1}$ is the model state, \mathbf{q} and \mathbf{v} are again noise to the system, and \mathbf{f} and \mathbf{h} are continuous functions differentiable by $\mathbf{x}(t)$.

For a locally linearized model,

$$\begin{aligned}\dot{\mathbf{x}}(t) &= \mathbf{A}\mathbf{x}(t) + \mathbf{q}; \\ \mathbf{y}(t) &= \mathbf{C}\mathbf{x}(t) + \mathbf{v}; \end{aligned} \tag{8}$$

where $\mathbf{A} = \frac{\partial \mathbf{f}}{\partial \mathbf{x}}$ and $\mathbf{C} = \frac{\partial \mathbf{h}}{\partial \mathbf{x}}$;

For the ARIES, the states are the globally referenced longitude and latitude in meters, X and Y , the heading angle referenced to North, Ψ , the vehicle's yaw rate from a rate gyro, r , the body referenced forward and lateral speed over ground, u_g and v_g , and a bias on the sensor readings from the rate gyro and compass heading, b_r and b_ψ . These values are all present in the system state vector, \mathbf{x} .

$$\mathbf{x} = [X, Y, \psi, u_g, v_g, r, b_r, b_\psi]^T \quad (9)$$

These values are each present in a nonlinear equation which must be solved to find their true values. These equations are represented in matrix form as the A matrix, which will be discussed in detail later in this chapter. However, the equations, seen below, represent how each state variable is used to dynamically determine each of the others.

$$\begin{aligned} \dot{X} &= u_g \cos(\psi) - v_g \sin(\psi); \\ \dot{Y} &= u_g \sin(\psi) + v_g \cos(\psi); \\ \dot{\psi} &= r; \\ \dot{u}_g &= 0; \\ \dot{v}_g &= 0; \\ \dot{r} &= 0; \\ \dot{b}_r &= 0; \\ \dot{b}_\psi &= 0; \end{aligned} \quad (10)$$

To solve for the equations and determine a solution for the state variables, the control system relies on the ARIES navigational sensors for measurements. The sensors provide data for the each of the states except the biases, which the filter is told to be naturally included in the measurement. The measurements enter the filter in the matrix form of a

matrix, Q , and the estimated states are converted, using a conditionally specified matrix, C , into the output matrix y . This matrix is in the form:

$$y = [u_g, v_g, \psi, X, Y]; \quad (11)$$

The equations, which are related in the C matrix and determine the output based on what the system is receiving from the sensors, are as follows:

$$\begin{aligned} y_1 &= u_g; \\ y_2 &= v_g; \\ y_3 &= \psi + b_\psi; \\ y_4 &= r + b_r; \\ y_5 &= X; \\ y_6 &= Y; \end{aligned} \quad (12)$$

This output is then used to determine the vehicle's position based on three separate methods. The first method, longitude and latitude, is a simple plot of the DGPS coordinates, which have been converted to meters, and referenced to the initial position. The second method uses traditional dead reckoning, in which the heading and speed are simply used to plot the vehicle's ground track. The final method for determining vehicle position uses a combination of method one and two, and attempts to determine the best possible answer, using the filter solution. This method will be more closely examined in the discussion on the ARIES Navigational Filter.

C. ARIES NAVIGATIONAL FILTER

The ARIES Navigational Filter is a crucial piece of the vehicle's software. It allows the vehicle to accurately navigate in and around the areas necessary to perform its missions, perform those missions with greater effectiveness by globally referencing its operational area and objects in that area, and finally, makes way for future progress in the

field of discovering new vehicle applications. All of these capabilities are enabled through accurate, low cost, vehicle navigation. An explanation of the vehicle's filter code, which can be seen as Appendix B, will describe how this is accomplished.

As previously mentioned the ARIES filter takes measurements from its sensors, and then estimates its position. These measurements, namely the Doppler forward and lateral speed, the IMU yaw rate, and the differentially corrected longitude and latitude, must be formatted, or pre-processed, to be correctly displayed and used in the correct units.

1. Data Pre-Processing

The longitude and latitude are both presented to the filter in the form of degrees and decimals of degrees. The filter code changes both of these measurements into meters. Additionally, to be correctly plotted, the filter references the entire latitude and longitude data set to the origin of the data (first data point). The heading measurement also requires correcting.

The heading measurement taken by the RDI compass is displayed as a positive or negative number of degrees, depending on which side of the North/South line the AUV is pointed. However, the filter requires continuous data without the attendant 360° discontinuity. Therefore, the heading is changed using a "Wrap-Count" method that allows the vehicle's heading to continue to grow beyond 360° if necessary, keeping account of the number of turns completed by the vehicle as it "winds up" and "unwinds" during turns.

For example, for one complete counterclockwise rotation, the old data format would show a plot from 0° to 180° , then an instantaneous 360° jump to -180° , and finally a plot from -180° up to 0° again. The new format will simply show a continuous plot from 0° to 360° . If the vehicle made two complete rotations, the plot would go from 0° to 720° , and so forth. Finally, after the format is changed, the heading is converted to radians. Once these corrections have been made, the filter is initialized.

As part of initialization, the filter defines the governing control matrices, and the time base it using to run recursively operate the loop. This time base is determined from the speed of the sensor that takes a measurement most frequently. After that the filter uses its previous knowledge of the system model to prepare the state dynamic matrix A , and inputs given bias and system noise matrices Q and R , it defines the output matrix C based on the measurement data. This can be better explained with a detailed look at each matrix.

2. A Matrix

The A matrix for the ARIES AUV is an 8 by 8 matrix defined using the known equations for underwater marine vehicle dynamics given as equation (10). These equations contain trigonometric relationships, which are the source of the system non-linearity. However those relationships are necessary to combine both globally and body referenced information. [Ref. 3] From the A matrix and the time base, the filter defines the state transition matrix, Φ , using the following equation:

$$\varphi = e^{A\Delta t} \quad (13)$$

Here dt is the nominal discrete time interval selected as the smallest of all update times, and also as the control time of 0.125sec. The matrix Φ will be computed at the beginning of the loop using the most recent linearization of f . The A matrix is reset at the end of every loop based on the most recently corrected state information.

3. Q Matrix and System Noise

The Q matrix gives the filter information about the expected levels of bias that are present when predicting the state. As is evident in the filter code, the Q matrix is composed, specifically of the eight values of variance. Each value is directly related to its numerically corresponding state variable. Each of these values may be adjusted to provided the best final results. The higher the value of the variance, the less weight the filter puts on that particular measurement. For example, because the DGPS latitude and longitude are considered to be "true" solutions for position, they are both assigned a variance of 0. However, due to problems with vehicle magnetic fields, it is expected that the compass measurement for heading will be slightly inaccurate, therefore it is assigned a variance of 0.001rad^2 .

Once a variance has been assigned to each measurement, the Q matrix is then created. The formation of the Q matrix is shown below.

$$Q = \begin{bmatrix} q1 & 0 & 0 & 0 & 0 & 0 & 0 & 0 \\ 0 & q2 & 0 & 0 & 0 & 0 & 0 & 0 \\ 0 & 0 & q3 & 0 & 0 & 0 & 0 & 0 \\ 0 & 0 & 0 & q4 & 0 & 0 & 0 & 0 \\ 0 & 0 & 0 & 0 & q5 & 0 & 0 & 0 \\ 0 & 0 & 0 & 0 & 0 & q6 & 0 & 0 \\ 0 & 0 & 0 & 0 & 0 & 0 & q7 & 0 \\ 0 & 0 & 0 & 0 & 0 & 0 & 0 & q8 \end{bmatrix}$$

The measurement noise is represented in the R matrix. The difference between the Q and the R matrix is that Q tells the filter the level of certainty, which it equates to each of the predicted state variables (9). R tells the filter how much noise it expects to receive on each of the measurement channels (11). Both matrices use a series of weights to convey this information. [Ref. 19] The system noise is entered into the filter code as six separate measurement noise values “ nu ”. Similarly to Q , R is formed assuming independence among channels.

$$R = \begin{bmatrix} nu1 & 0 & 0 & 0 & 0 & 0 \\ 0 & nu2 & 0 & 0 & 0 & 0 \\ 0 & 0 & nu3 & 0 & 0 & 0 \\ 0 & 0 & 0 & nu4 & 0 & 0 \\ 0 & 0 & 0 & 0 & nu5 & 0 \\ 0 & 0 & 0 & 0 & 0 & nu6 \end{bmatrix}$$

By changing the values of Q and R , the filter may be manipulated to do such things as allow for more or less filtering, which adds or takes away from data smoothing. Additionally, those same values can also speed up or slow down the recursive process.

4. Asynchronous Data Processing

The output matrix should numerically represent conditions that are necessary to ensure the filter program uses new measurement data to determine the AUV’s position. It is possible that the correct measurement information may not be given to the filter, due to the idea of asynchronous data. This problem needs to be specifically addressed in order to keep the filter running without errors.

a. Asynchronous Data Problem

The measurements coming from the AUV sensors are not produced at the same rate. This is not to say that the information is produced out of phase, but it is rather, produced at different frequencies. Specifically, the DGPS data is updated at a rate of 1Hz, the RDI Doppler at 2Hz, and the IMU is the fastest at 100Hz, but is only sampled and given to the filter at 8Hz.

Ideally, the navigation filter program should run at a speed that is faster than the speed of the fastest sensor. This way the filter can determine the new position before any new measurements are taken from the IMU. However, because only the IMU data is updated every 0.125sec, a problem arises when the filter tries to use the old measurements from other sensors, along with the new IMU measurement, when it determines the AUV's position.

b. Asynchronous Data Solution

The solution to this problem has two parts. The first part is filling in the holes for measurements that are not given as often as the most frequent one. The second part ensures that none of those placeholders are actually considered towards the calculation of the vehicle position. Together, these two parts allow the filter to adjust position with every update IMU, or less than every 8Hz.

To fill in for data that is not given at 8Hz, there is some preprocessing done in the AUV software. For the ARIES AUV, this is accomplished in the C code which parses incoming measurement data from each sensor before it reaches the filter, so that only the previously specified data, necessary for calculating vehicle position, is sent

to the vehicle's shared memory. This same code ensures that measurement state representing a sensor that did not produce an updated measurement, remains unchanged until an update is received. This way there is a measurement present for each part of the measurement vector. The second part of the solution shows how the C matrix allows the filter to determine an updated position, when the measurements are not always updated themselves.

If a value is to be kept in the filter process, or considered useful, then the C matrix coordinate for that data point will be set to 1, and carried on to the output. For example:

$$y(i+1,4) = \text{new}; \therefore C(4,:) = \text{nominal } C(4,);$$

Here $y(i+1,4)$ is the next data point on the 4th measurement channel.

If it is not useful, the coordinate point is set to 0 and the information does not continue on any further. For example:

$$y(i+1,4) = \text{old}; \therefore C(4,:) = 0;$$

The following criteria are used in the ARIES filter program.

- If the new latitude and longitude caused the square root of the error covariance, relative to the previous data, to be greater than 1000, the new data is not to be used.
- If the forward and lateral Doppler speeds have an absolute value of over 10m/s, that data is not to be used.
- If any new data is equal to the old data, the new data is not to be used.

After each matrix is created and manipulated to first predict and then correct the state estimation, the resultant position is presented to the vehicles tactical computer. From this point the filter continues to run over and over until the end of the mission, and the information it delivers to the tactical computer is used to compose the vehicles next plan of action, or corrective measure, to reach its mission objective.

THIS PAGE INTENTIONALLY LEFT BLANK

V. RESULTS OF EXPERIMENTATION

A. INTRODUCTION

Several independent periods of experimentation were required to completely qualify the entire Navigational Suite. Because the entire system relies on the accuracy of the DGPS, the Suite's evaluation was broken down into the qualification of its major components, the base DGPS, and the dependant, recursive navigational filter. This qualification was accomplished by first evaluating the proposed DGPS setup, then testing the chosen setup in open water conditions, and finally configuring and testing the Navigational Filter in conjunction with the DGPS in those open water conditions. This chapter will discuss the most progressive highlights of those experiments. It should be noted that due to the experimental nature of this "first" testing sequence, the results seen do not reflect the full quality of the much-improved "final" data, currently collected from the finished system.

B. EVALUATION OF DGPS SETUP

The first set of experiments with the ARIES were composed to merely ensure the system components interacted as predicted, and were able to produce acceptable results. These results were carried out on land, at a parking lot located in front of the Naval Postgraduate School (NPS) Center for AUV Research laboratory. In total, five experiments were conducted.

The Base Station was set up near the laboratory's front door, with the antenna stand located outside in the previously mentioned parking lot. The vehicle was power-

up, so the DGPS components inside it would be operating, and placed on a flatbed loading cart. The cart was then brought to the parking lot where each experiment would then be carried out. Finally, a GPS file was collected by the AUV's CPU. That recording process was initiated from the Base Station, running "Procomm" on a remote personal computer (PC) to login and execute files inside the AUV computer, via radio modems. The recorded file was later pulled from vehicle's CPU using a direct Ethernet cable (in the interest of speed, though the file is accessible via radio modem), and analyzed using several MATLAB programs which can be seen as Appendix B.

The data is presented here in a series of 3 figures and a table of DGPS statistics for each test. The first figure is a geographical plot which shows the GPS fixes as a marker, and a track line connecting fix to fix. The second figure is a histogram of the number of satellites detected by the DGPS while take each fix. The final figure tracks the DGPS DOP during the test. This figure shows comprehensive DOP called Positional Dilution of Precision (PDOP), as well as its individual components, the Horizontal, Vertical, and Time Dilution of Precision (HDOP, VDOP, and TDOP). Finally, the table of statistics provides the total number of recorded data points, the number of those points which were accompanied with available differential corrections, and the number of those points which were taken while the DGPS was in view of 5 or more satellites.

It should be noted that there was some interference present in the vehicle's ability to receive signals from the GPS satellites due to the overhanging trees surrounding the parking lot, as well as the laboratory itself. However, due to the basic nature of these experiments, as well as the fact that the desired results were produced, the experiments were all held at this location, and deemed successful.

1. Stationary Test

The first test conducted was a stationary test. The importance question to be answered during this test is not “Will the vehicle’s position drift, or change gradually”, but instead, “How much will it drift?” Because the system uses the GPS signal offered to the public, as discussed previously, some drift will occur. However, the vehicle will be required in some missions, to find and maintain a specific point on the globe with only DGPS information. Therefore the AUV Navigational Suite needs to be able to identify a specific set of DGPS coordinates, and maintain them with little variation, regardless of the quality or SS it receives.

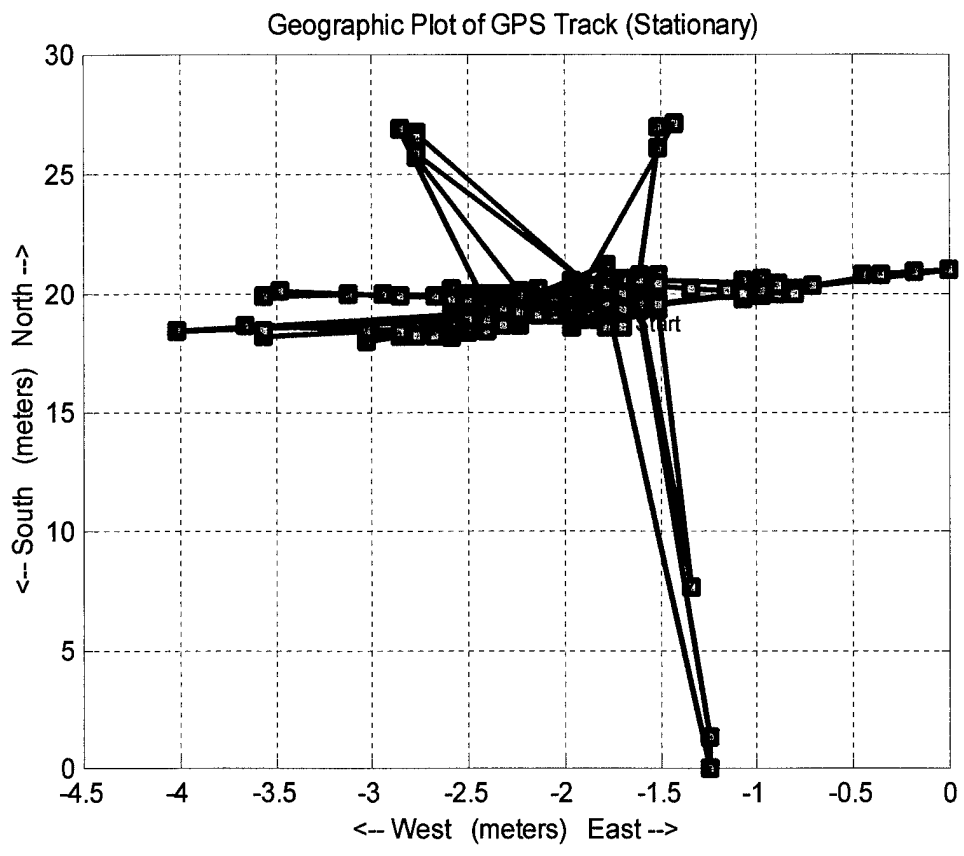

Figure 5.1: Stationary Test Geographic Plot

Figure 5.1 shows the results of the Stationary Test. These results were obtained by leaving the vehicle static for approximately 440sec, or 7.33min. During that time, the vehicle drift is significant, but no more than expected. The center point of the data, in this case is not the same as the origin of the plot's axes.

The program, which analyzed the data, is instructed to label the axis origins at the position of the data points located farthest east, and farthest south. However, due to some environmental interference, those data points may not be the most accurate measurements of vehicle position possible. Thus the center point of the data is determined, and the drift results were compared to that point.

The E-W drift of the vehicle data is over a range of 4 meters, but with a variation of 2m from the observed center point of the data. However the N-S drift is within a range of 26.5m, with a max variation of 19.2m from the center point. This is mainly due to only a few errand data points, which is caused by a drop in the satellite signals. When the number of satellites the vehicle can see drops below 5, the vehicle is forced to use exactly the information it gets, and is not able to choose the best data from the satellites with the best DOP. Figures 5.2 and 5.3 show the data's histogram for the number of satellites, as well as a plot of the DOP with respect to time.

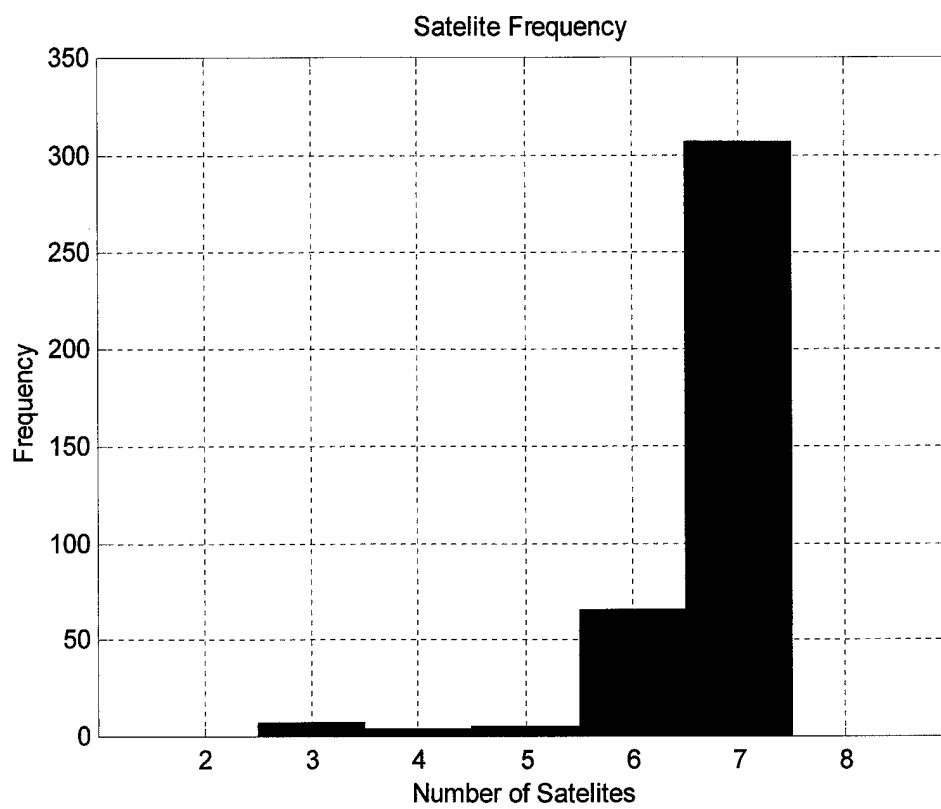

Figure 5.2: Histogram of Stationary Test Satellites.

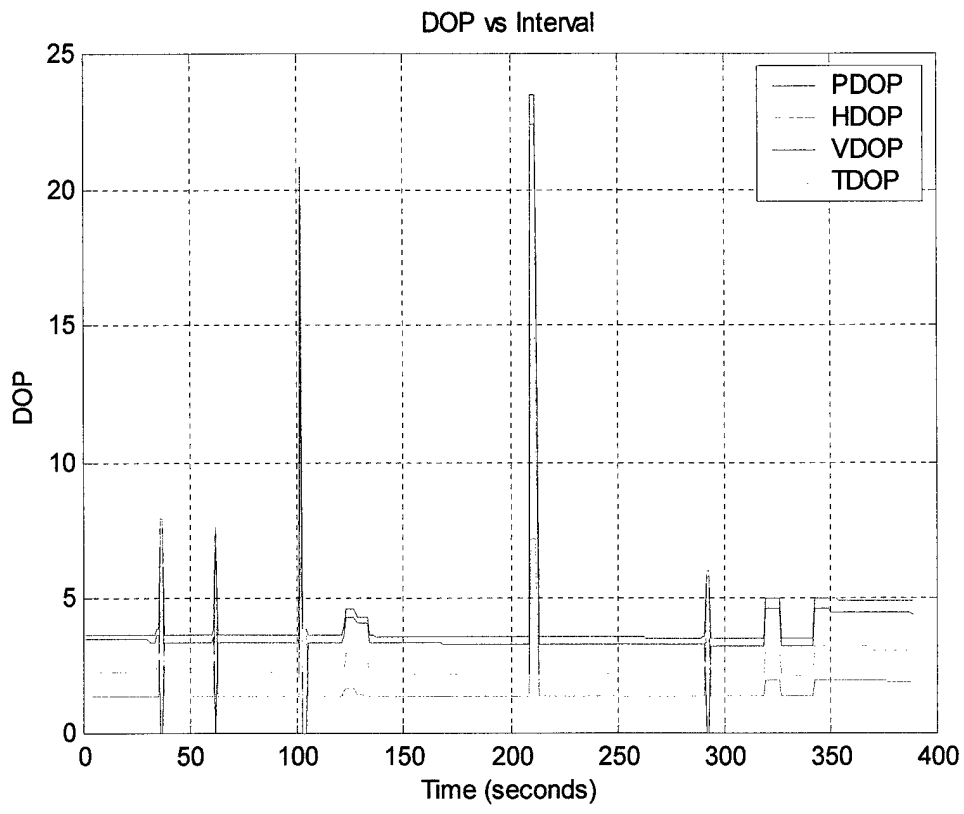

Figure 5.3: Stationary Test DOP Plot.

The histogram shows the only 11 data points had less than 5 satellites in view when the position was recorded. The DOP plots show that excluding those 11 data points, the dilution of precision remains under five for the entire data set. This means that on a scale of 0 to 100 for probability of error content, the data set remains around 5.

Though the geographic plot does indeed show a few errand points, the large majority of the points are within the desired speculations. In fact, Table 5.1 below shows the most important data obtained from this experiment.

Number of Fixes	440
Number with Differential	389
Number with >4 Satellites	378
Percentage of Useful Data	85.9

The important information to note is that out of the 440 fixes recorded, 85 percent of them were within the requirements. Figure 5.4 shows that if the remaining 14.1% of the data points were removed, which can be done by raising the G-12's threshold for accepting the number of satellites, the stationary plot returns results within 2m precision.

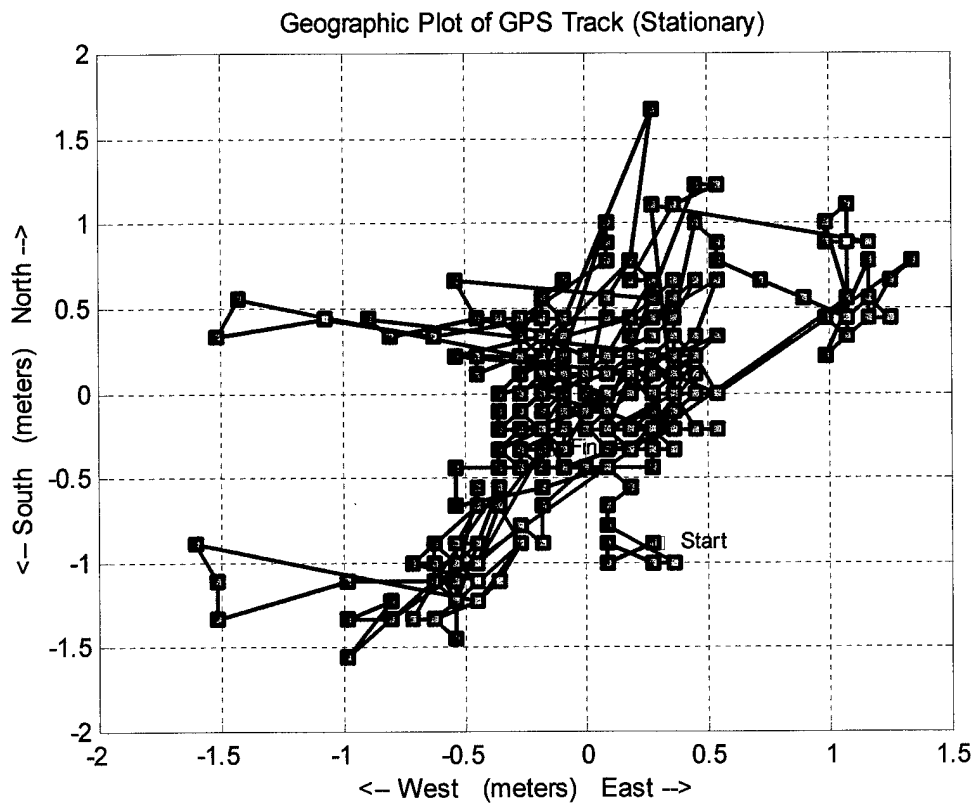

Figure 5.4: Stationary Test Geographic Plot (Corrected).

2. Motion Tests

The next test carried out in the parking lot was a simple motion test. The purpose of this test was to find out if the DGPS could keep a signal between the Base Station and the AUV while it was in motion. Two supplementary things examined during this test were the vehicle's ability to track satellites while in motion, as well as whether or not it was capable to distinguish a specific shape created by the vehicle path.

The path taken by the vehicle was planned to be a circular pattern. Table 5.2 below shows the statistics of the data set. This time, those points without differential corrections, or less than five satellites have been recorded initially, but were filtered out of the geographic positioning.

Number of Fixes	348
Number with Differential	262
Number with >4 Satellites	262
Percentage of Useful Data	75.3

During this test, the percentage of useful data declined slightly, however, the number of data points taken did as well. Therefore it could be said that the number of bad data points per run could be somewhat constant, due to the vehicle's path through a specific part of the parking lot. Figure 5.5 shows the geographic plot of the track, while figures 5.6 and 5.7 show the Satellite Histogram, and the DOP plot.

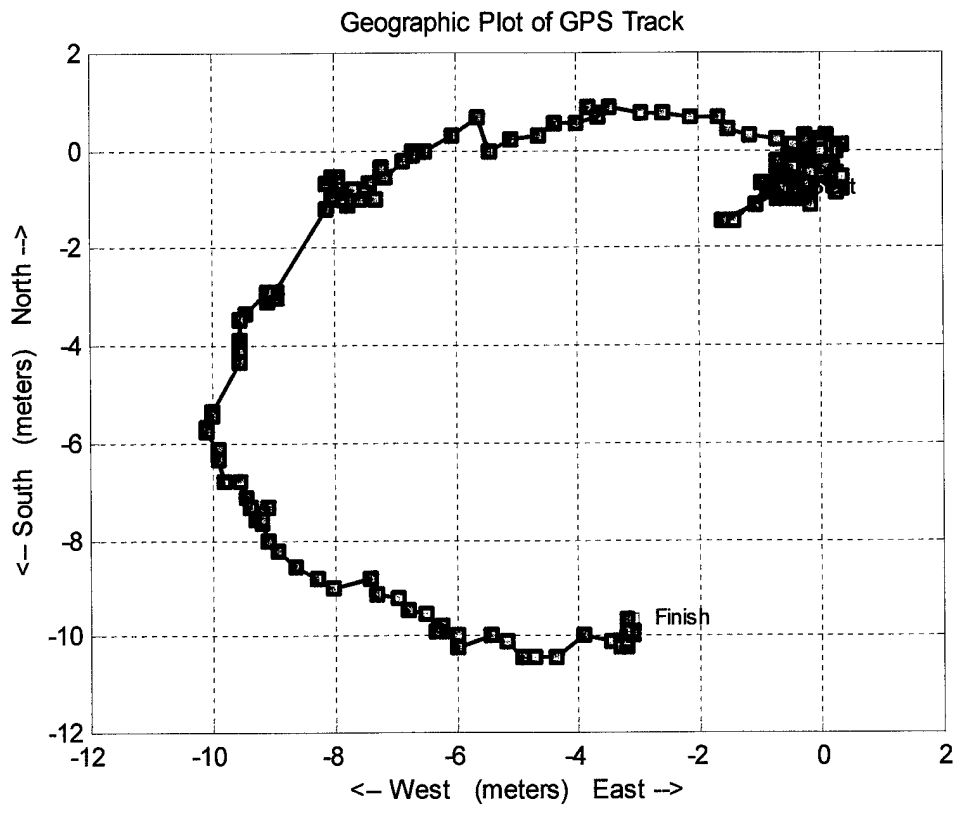

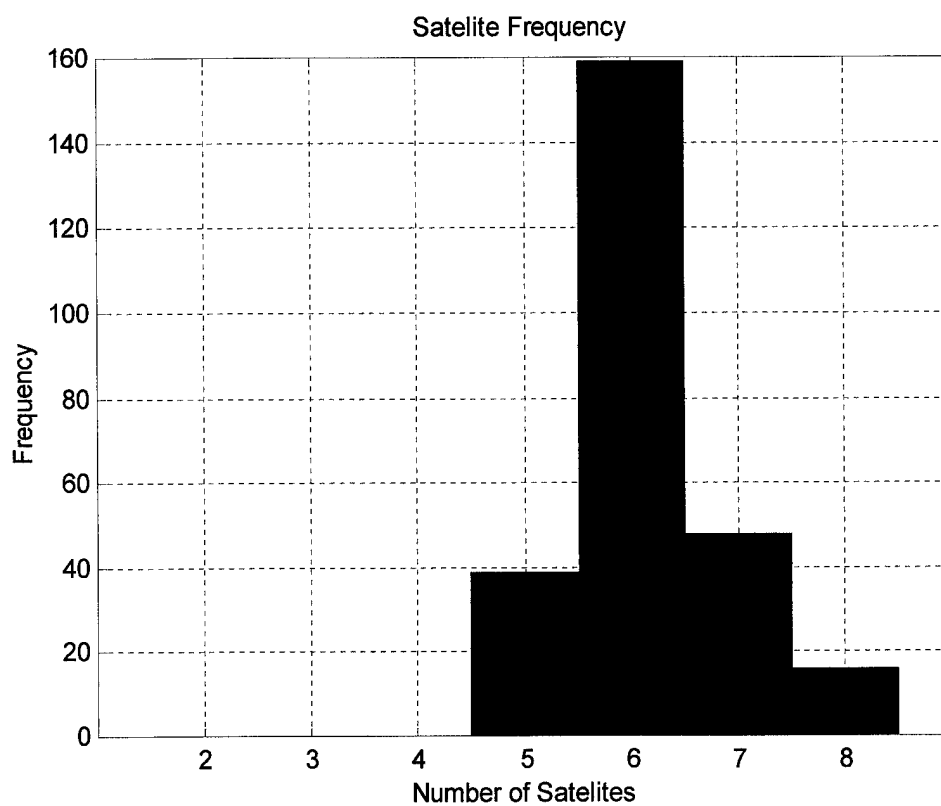

Figure 5.6: Histogram of Motion Test Satellites.

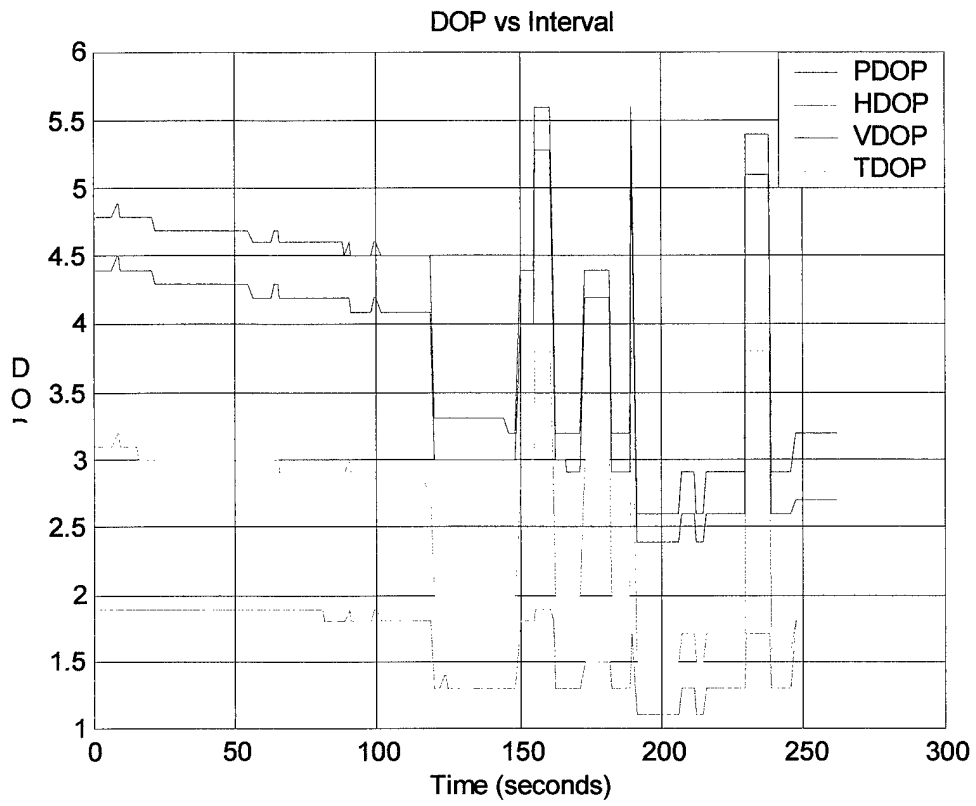

Figure 5.7: Motion Test DOP Plot.

The geographic plot shows that the vehicle clearly made an incomplete circular pattern. Also, during this test the vehicle maintained a DOP below 6, and was able to use 75% of its recorded data points. Therefore the DGPS shows it can operate under conditions of motion, and the test was considered to be successful in meeting its objectives.

3. Shape Test

The final planned vehicle test was intended to see if the path recorded by the CPU could be used to accurately measure a physical distance. The previous test had proven that the physical shape of the path could indeed be recognized, but how much did the dimensions of that shape suffer due to inaccuracies in the GPS coordinates.

While carrying out the test, a square path of the dimensions 36x24ft was marked off in the parking lot. The vehicle was then towed around this track. Again it should be noted that due to the size of the track, and the size of the parking lot, the results of the southern most path of the track are somewhat plagued by the vehicle's immediate proximity to the laboratory. However, the statistics, as seen in Table 5.3, show that the vehicle was still able to use 76% of its recorded data.

TABLE 5.3: Shape Test Statistics	
Number of Fixes	290
Number with Differential	223
Number with >4 Satellites	223
Percentage of Useful Data	76.9

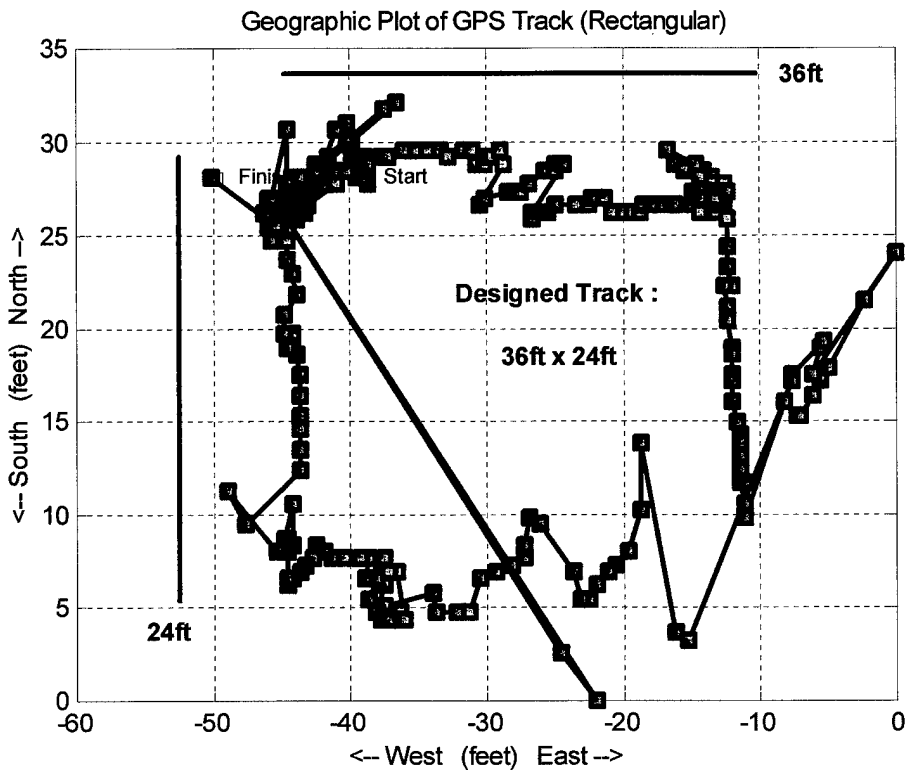

Figure 5.8: Shape Test Geographic Plot.

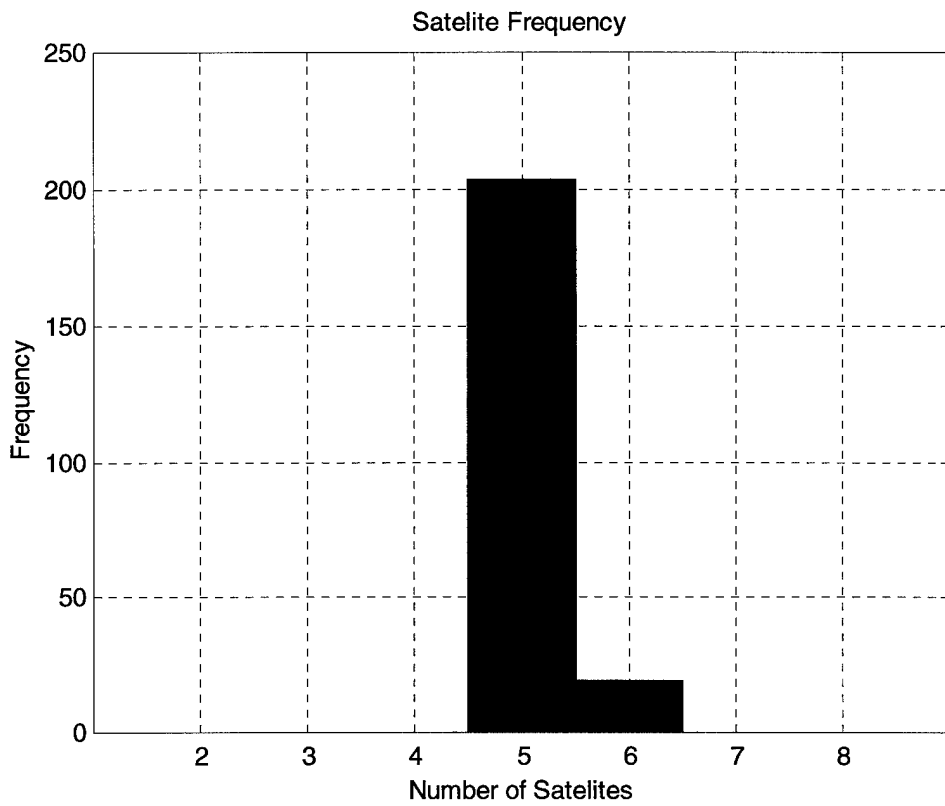

Figure 5.9: Histogram of Shape Test Satellites.

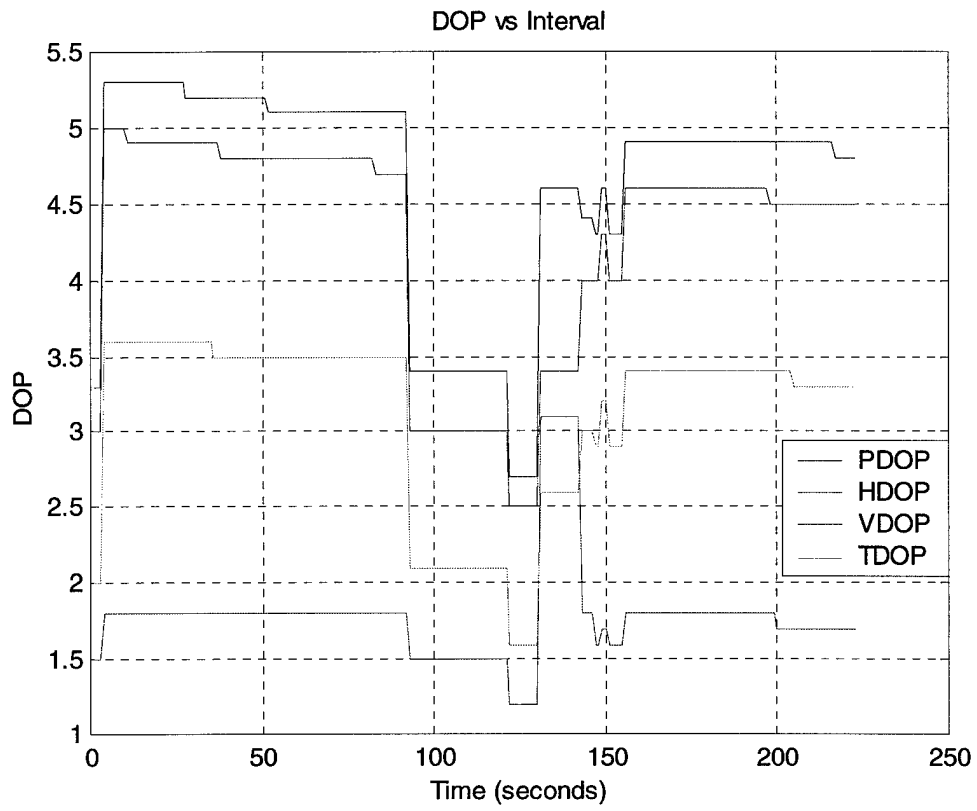

Figure 5.10: Shape Test DOP Plot.

The AUV's geographic, histogram, and DOP plots (Figures 5.8, 5.9, and 5.10) show that the vehicle was able to measure the path length closely. It can also be easily seen that the tracks compose the four sides of the box. An analysis using linear regression shows the data exhibits a standard deviation better than 30cm. The histogram shows at least 5 satellites while positioning, and the DOP shows no greater than 5.25.

The results from these tests very considered satisfactory enough to allow the DGPS setup to be accepted. The system was next moved to the Monterey Bay for its official qualification in the open-water.

C. OPEN-WATER QUALIFICATION OF THE DGPS

The objective of the DGPS open water tests was to determine if the existing setup could operate effectively in the ocean. "Effective" operation means that the AUV will be able to maintain contact with the satellites while on the water's surface, and effectively track its position. If this objective could not be met, then the setup would have to be altered.

A specific concern to be observed in the results, was AUV's ability to receive signals from all associated sources, while being located so close to the water. Due to the fact that both the command/control/differential and GPS antennae are both approximately 4 to 12in out of the water, while the vehicle is located on the surface during an average Sea State of 2, either may not be able to distinguish a strong enough signal.

The tests were conducted in the Monterey Bay, at the Public wharf. The AUV was loaded at the lab and brought to the wharf in a trailer. A public crane at the wharf was used to lower the AUV into the water, where it would then be towed out into the

open water by a two man team or researchers in a Zodiac inflatable boat. Once positioned in the open water, and powered by triggering it's magnetic switch, the vehicle CPU was then commanded to begin recording data from the Base Station CPU.

The Base Station was located half way along, and on top of the pier, approximately 15-20ft above sea level. From this vantage point, the Base Station could remain in contact with the AUV for transmitting command and control information, as well as differential corrections.

The differential corrections and GPS information from satellites were received and recorded by the AUV, and downloaded the end of the mission. The vehicle was towed, on the surface of the water, during the entire test.

1. First Test Results

During the first test in open water it was discovered that the AUV DPGS tracked the vehicle's path very well for the first radial mile. Figure 5.11 shows the exact geographic path the AUV took during the test.

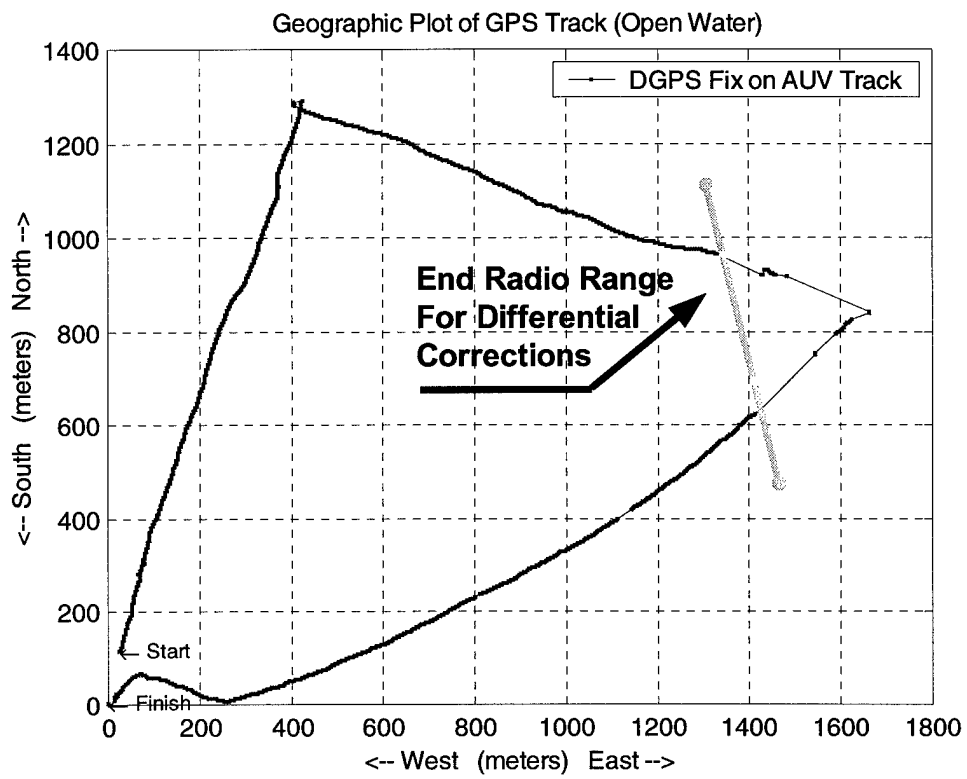

Figure 5.11: Open Water Test Geographic Plot.

This plot shows that the AUV was towed in a triangular pattern, during which its Navigational System was able to accurately position the vehicle during the majority of the run. However, at the eastern most corner of the plot, the vehicle was not able to receive many DGPS fixes along its track.

The reason for this lack of DGPS positioning, is found with a closer analysis of the system which provides differential corrections. After checking the results for any specific problems, it became apparent that at the eastern most corner, the vehicles farthest point from the Base Station, the recorded data had not received any differential corrections. . This indicates that there is a range limitation of the differential correction radio link.

However, it was also noted that there was a loss of command and control at that time as well. This was well within the previously tested radio range of the vehicle. Since both the command and control, and the differential corrections systems share the two-way antenna through a 75ohm combination/splitter called a “Mulitplexer”, one of these components must be the culprit. Table 5.4 below shows exactly how that data effected the vehicle’s percentage of useful data.

TABLE 5.4: Open Water Test Statistics	
Number of Fixes	3496
Number with Differential	2508
Number with >4 Satellites	2195
Percentage of Useful Data	62.8

Because the data that does not show the use of differential corrections is not considered useful and/or plotted at this stage in the testing, The 628 fixes taken during the

signal outage were lost when the filter discarded all GPS fixes that did not have differential corrections. Therefore, they were unable to be plotted, but were still represented in Table 5.4. It should be noted that the actual Navigation Filter used in the AUV accepts raw GPS and DGPS data, but weights them for confidence using predetermined error bounds, which consider if differential corrections are present or not. However, for testing purposes, where the objective is the highest standard possible, regular GPS fixes are less than ideal and therefore not considered.

Acknowledging the fact that the Sea State on this day was only a 1, the small aerial was able to receive position information from the satellites for the majority of the run. However, Figures 5.12 and 5.13 show results that both support and conflict the idea that the aerial was working as well as it could have been.

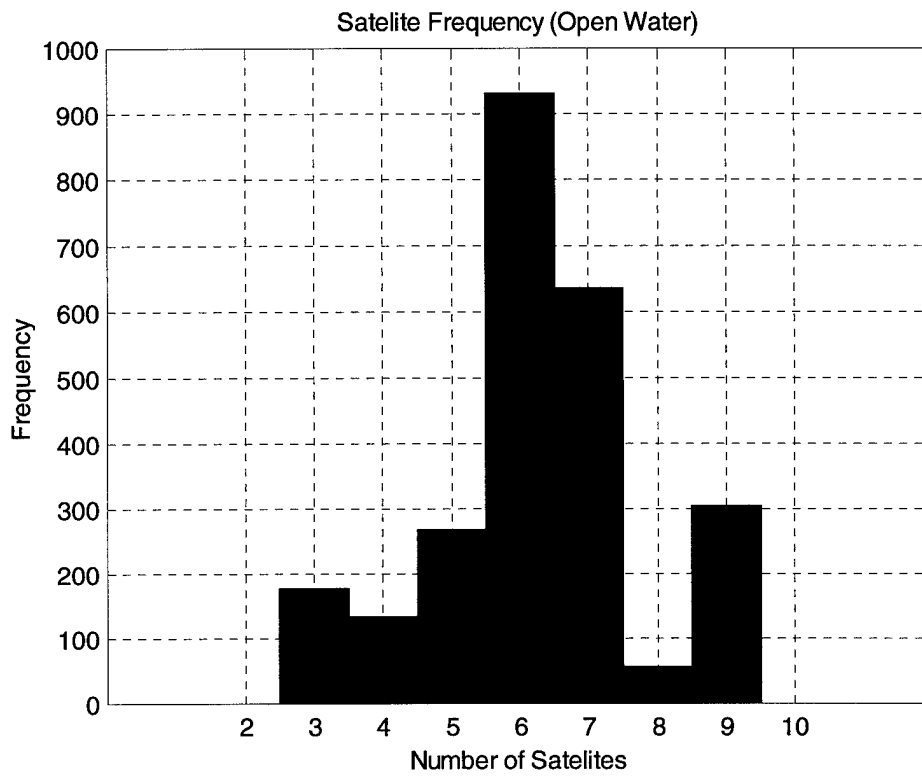

Figure 5.12: Histogram of Open Water Test Satellites.

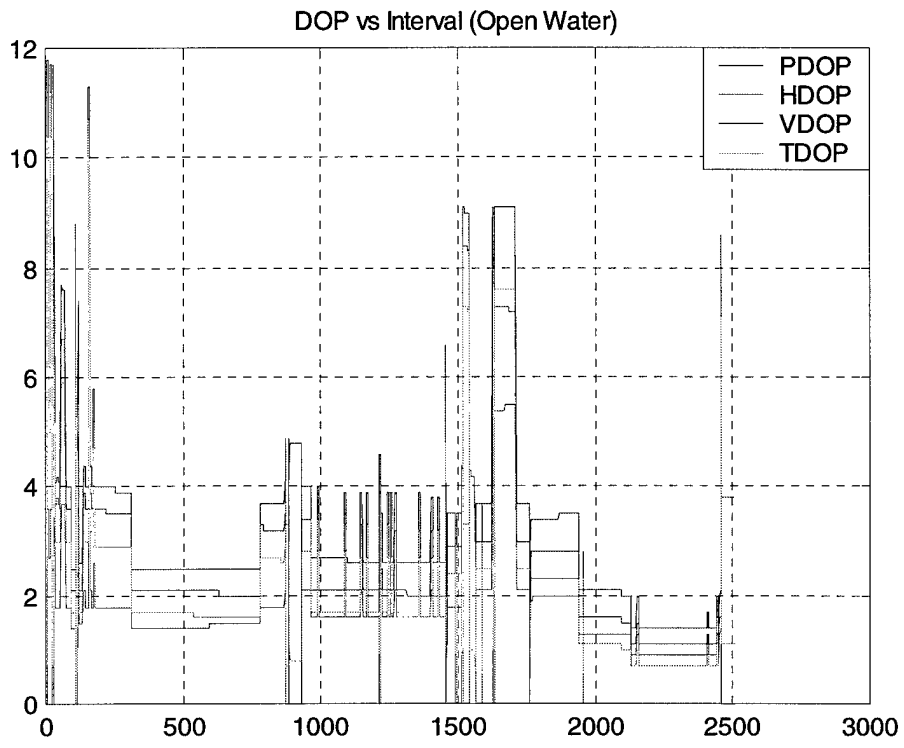

Figure 5.13: Open Water Test DOP Plot.

The satellite histogram shows that the AUV was able to pick up a mean of 6 satellites, with a maximum of 9 satellites, during the run. However, as was seen in Table 4.4, only 62% of the data had five or more satellites. In the open ocean, 5 or more satellites should be visible at all times. This is the first indication of a potential problem occurring in relation to the aerial.

The DOP figure supports the latter fact by showing that even though DOP values average about 3.3, there is a greater frequency of the occurrence of DOP peaks, which range as high as 11.8. This data works in conjunction with the fact that aerial was repeatedly unable to receive a signal from more than 5 satellites. The GPS receiver was therefore forced to except those signals as the best possible, for triangulation. Once again, because better results we expected from the GPS aerial, several changes were made before the next test.

2. System Troubleshooting

A closer examination of the two-way antenna found it to be faulty. The connection at the internal base of the antenna was loose, which caused a severe decrease in its receiving range. It was replaced before the next experiment by a similar antenna manufactured by the same company. The only difference between the new and old antennae was that the design had been modified so that the new antenna was only 12 inches long, vice 24. The GPS aerial was also examined for potential problem sources, as well as possible better methods for its implementation. This examination identified two problems.

First, due to the series of several connections and cables between the aerial and GPS receiver, including a hull *connection*, the aerial's sensitivity was being reduced due to impedance mismatching. To rectify this situation, the hull connection, as well as the internal connecting cables, were removed. A single cable connecting the aerial directly to the GPS receiver was then added, and passed through a new hull *penetration*. The difference between a hull connection and a hull penetration is that there is no break in the line through a sealed penetration. The second change made to the aerial was the addition of a ground plate.

Considering that the previously mention SS problem may have indeed been caused by the aerial proximity to the water, a ground plate would provide optimum signal reception for the aerial by reducing any signal reflection from the water's surface.

3. Second Test Results

After the modifications were made to the ARIES's DGPS, the tracking results observed, during all subsequent tests, showed a very high level of improvement. The results of one such test show this improvement, boasting 100% production of useful DGPS fixes with 5 or more satellites. Table 5.5 below shows the data's statistics.

TABLE 5.5: Open Water Test2 Statistics	
Number of Fixes	1807
Number with Differential	1807
Number with 4< Satellites	1807
Percentage of Useful Data	100.0

This particular test was no different than the previous open water test, with regards to environmental conditions or procedure. However, it is noticeable that during this run, the system was able to maintain contact with the Base Station, as well as receive good GPS satellite data from a large number of satellites then entire time. Figures 5.14, 5.15, and 5.16 provide more detailed information about the test.

The geographic plot shows that during the test, the AUV was simply towed out in one direction (NE), and then towed back. As mentioned earlier, the Sea State was no different than the previous open water test. However, the figure shows there was no point along the track (blue line) which was not covered by GPS fixes (red points).

The satellite histogram shows the GPS aerial was able to receive a strong signal from a mean of 8 satellites throughout the length of the track. Due to this fact, the DGPS was also able to maintain good DOP during the test, which is shown in Figure 5.16. The average DOP value is 1.8, which is a 43% decrease over the first open water test, and never rises over 6.9, a 42% decrease.

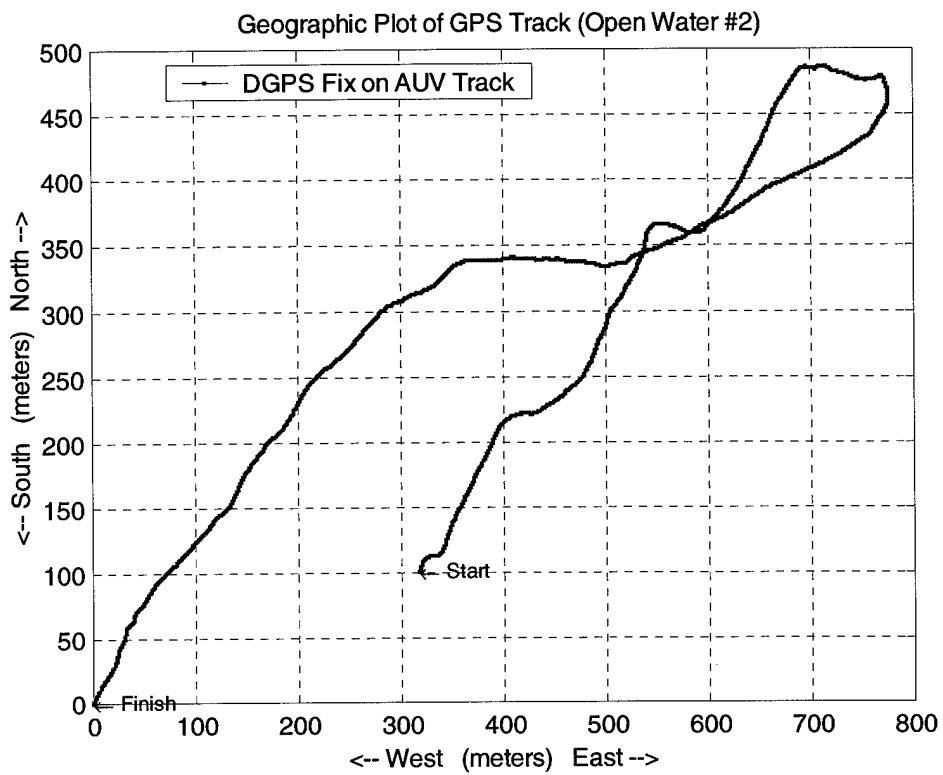

Figure 5.14: Open Water Test #2 Geographic Plot.

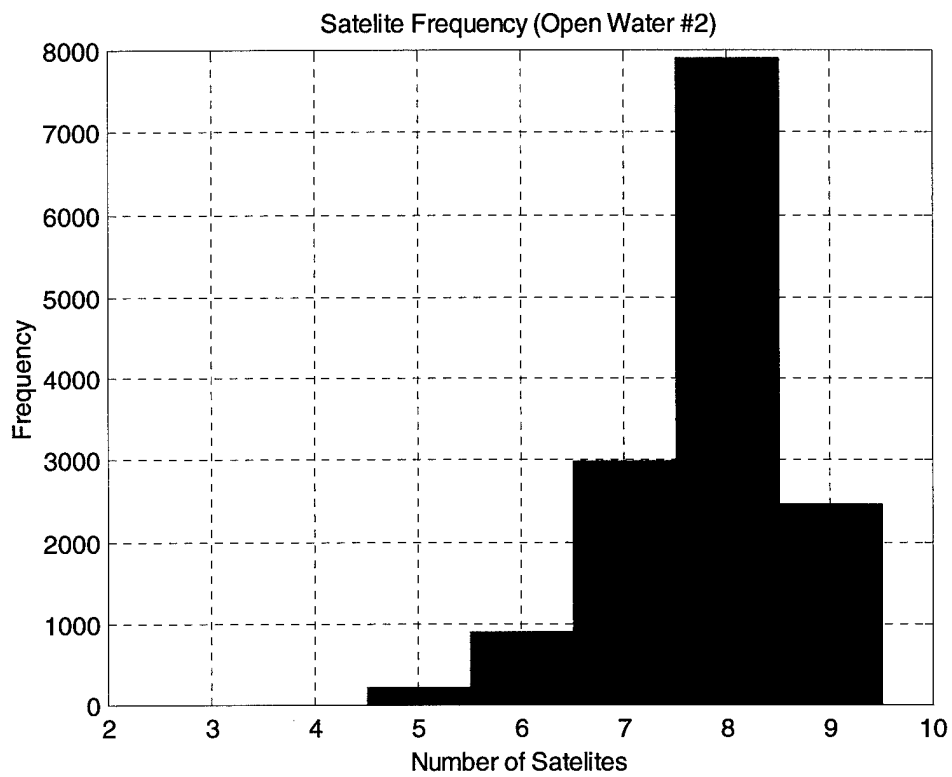

Figure 5.15: Histogram of Open Water Test #2 Satellites.

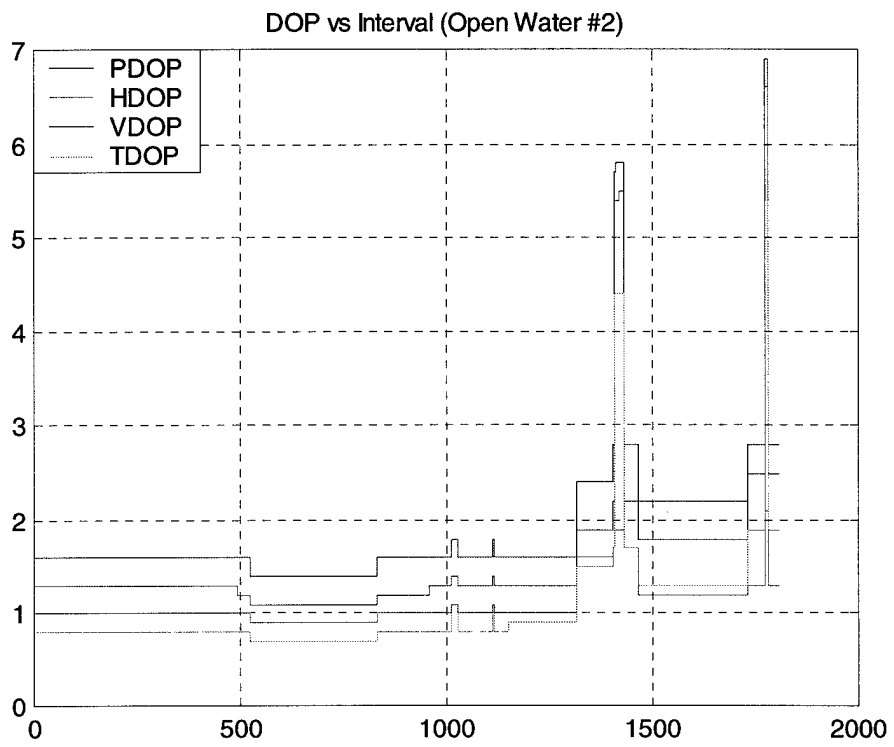

Figure 5.16: Open Water Test #2 DOP Plot.

The results of this test clearly qualify the DGPS for operation in the open water environment. The one aspect of testing which was not observable from this test, however, was the extended range of the DGPS from the Base Station, with the modifications to the antenna. This range however was lengthened to the original expected value, over 1.5 miles. This will be noticeable in the geographic plots of the filter tests, which were carried out after the open water test. These tests allow the DGPS to work in conjunction with the other components of the Navigational Suite, towards the comprehensive control of the vehicle.

D. EVALUATION OF THE DGPS BASED NAVIGATIONAL FILTER

The Navigational Filter tests intended to evaluate the degree of accuracy with which the filter program could estimate the geographical position and orientation of the ARIES AUV. This objective was met by attempting to prove two specific points. First, the Navigational Filter provides a better estimate of the vehicle's position than a system, which used only DGPS or dead-reckoning alone, would provide. Secondly, the properties of the filter can be adjusted to reduce geographic error on long underwater runs, to nearly the precision attained with surface navigation. Once again, all tests were carried out in the Monterey Bay. However, there were several differences between the filter and GPS tests.

All of the described components in the Navigational Suite were operational during these tests. Each sensor provided synchronized data to a time stamped file during the AUV's run. This data was then pulled from the AUV and analyzed using MATLAB code that simulates the ARIES Navigational Filter. [Ref. 20] The modified version of

this code, which is used during these tests, can be seen as Appendix C. Unlike the previous DGPS tests, it is necessary to run all of the vehicle's navigational sensors for the filter to estimate position.

In addition, during several tests in which dives were conducted, the vehicle's thrusters and control planes were operational. The vehicle was commanded to perform self-propelled dives for specified time intervals to observe the filter's behavior with no DGPS data. Such tests also proved useful for observing the resultant time it took the filter to estimate the vehicle's position after DGPS was reacquired, as well as providing visual foundation for the specific kinds of filter property adjustments that would be beneficial for AUV positioning.

1. Navigation Filter

The first objective was to prove that the filter could provide better position estimates than a system, which uses only DGPS or dead reckoning. Therefore two tests, one entirely on the surface, and the other which contained a series of AUV dives, were performed to provide a comparison of the separate navigation methods.

The first test simply towed the vehicle from "Fisherman's Wharf" in Monterey, out into the bay and then back again. During this run, the time stamped file was filled with navigational data by the sensors, and afterwards the results were observed for accuracy. The figure below shows a plot of the vehicle's track.

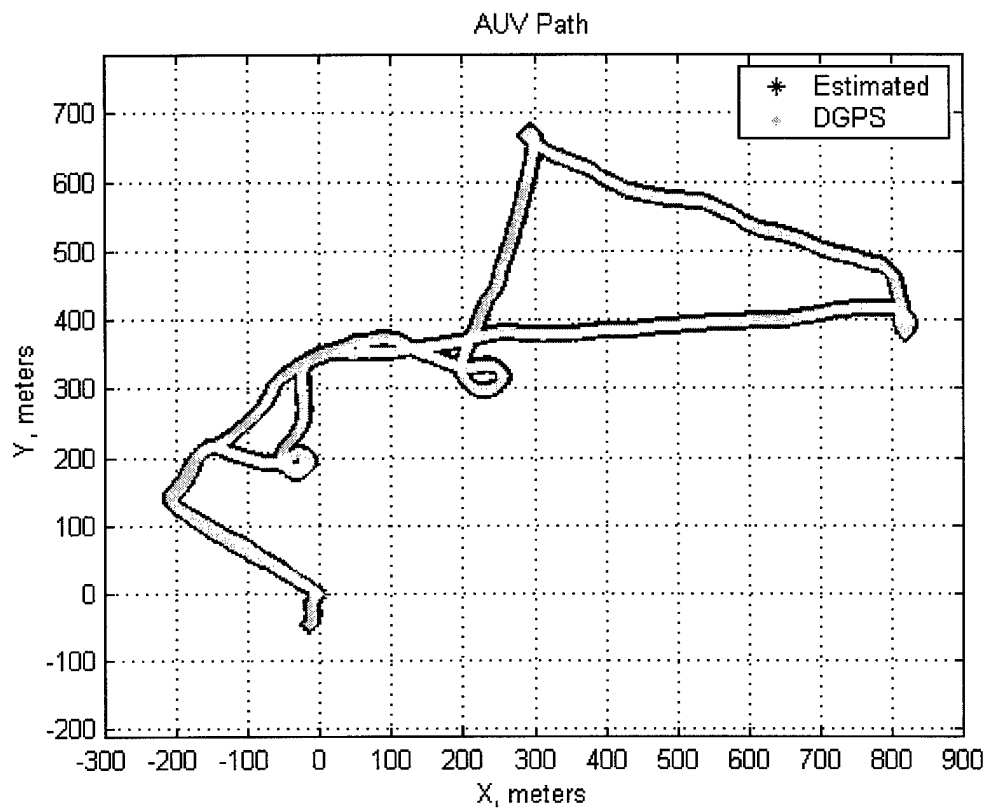

Figure 5.17: Filter Test #1 DGPS and Filter Track.

The blue points seen in Figure 5.17, are the DGPS fixes that were taken by the AUV along the track. The green points are the Filter's estimate of the track. Because the DGPS provides a geographic fix for the AUV every second, with sub-meter accuracy as discussed earlier, the filter weights the DGPS solution very heavily. Therefore, the filter is able to track the AUV's position exactly along with the DGPS fixes. At the same time, the filter is able to learn a little about the biases present in its own sensors.

As the sensors send data to the filter, it keeps track of exactly where the compass, Acoustic Doppler, and IMU say it should be positioned, using a dead reckoning solution. This occurs even if the dead reckoning solution does not agree with the DGPS solution. When these solutions do not agree, because the DGPS has been weighted more heavily, it is accepted as the "true" solution. Therefore, the filter is now able to measure the error between the two solutions, and correctly attribute it to the two biases it has estimated. Figure 5.18 shows the heading the filter estimated as it compared to the compass heading, and Figures 5.19 and 5.20 show the resultant measure of the yaw rate, and compass bias estimated by the filter during the test.

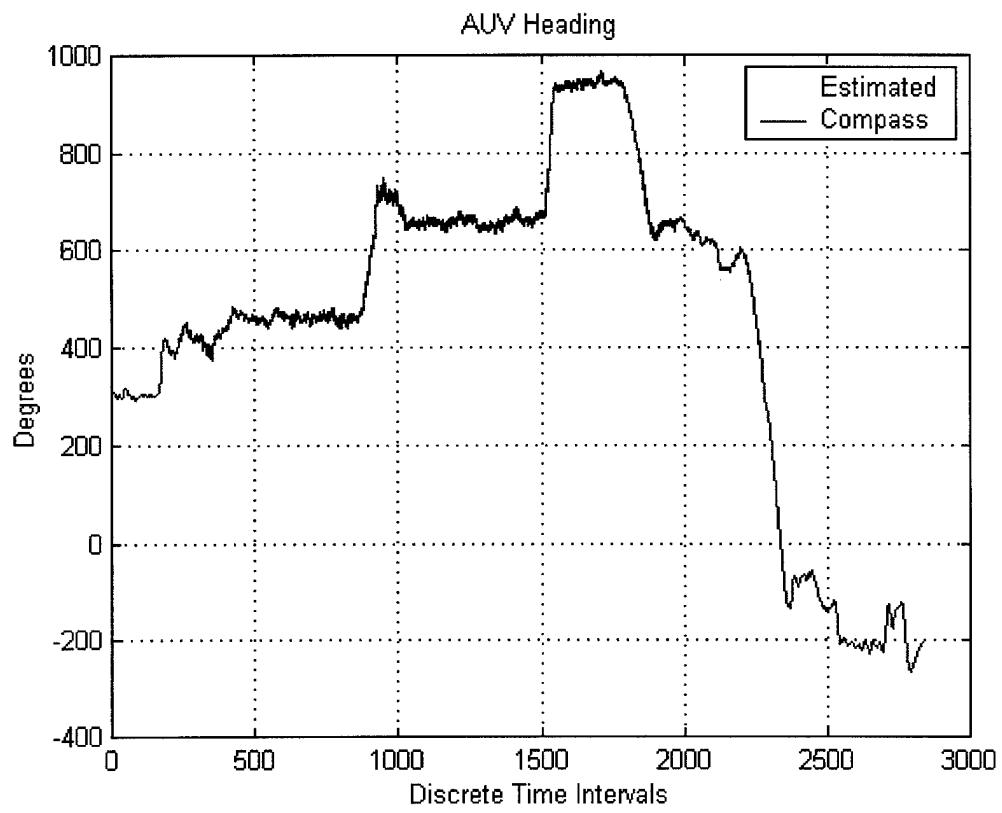

Figure 5.18: Filter Test #1 AUV Heading.

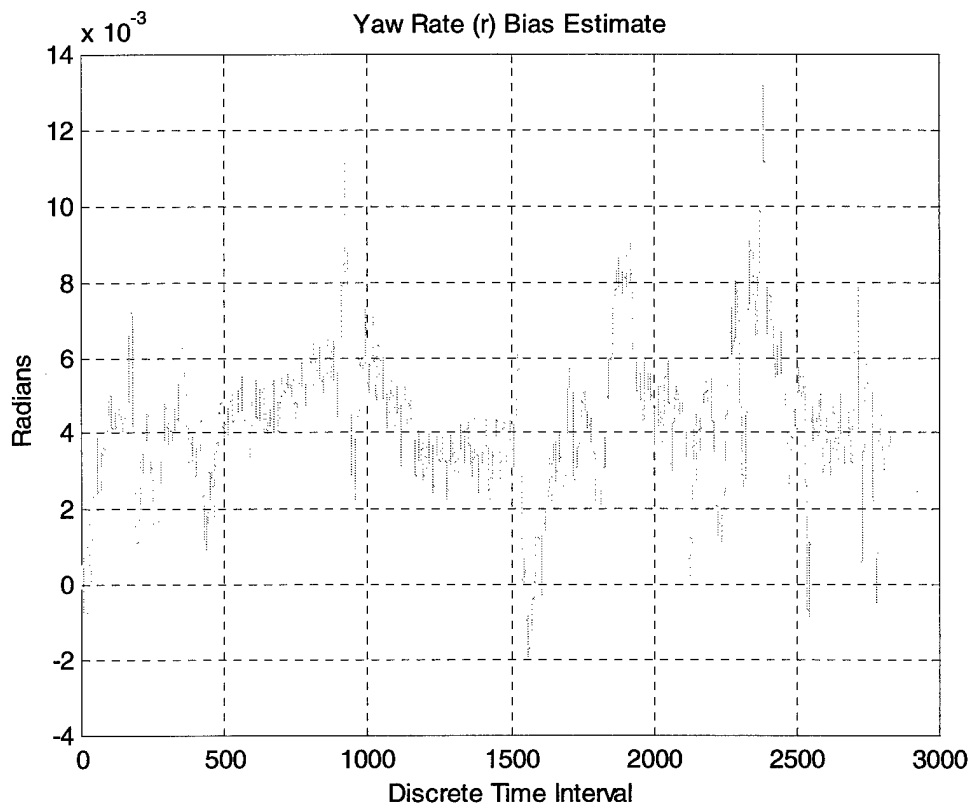

Figure 5.19: Filter Test #1 Yaw Rate Bias.

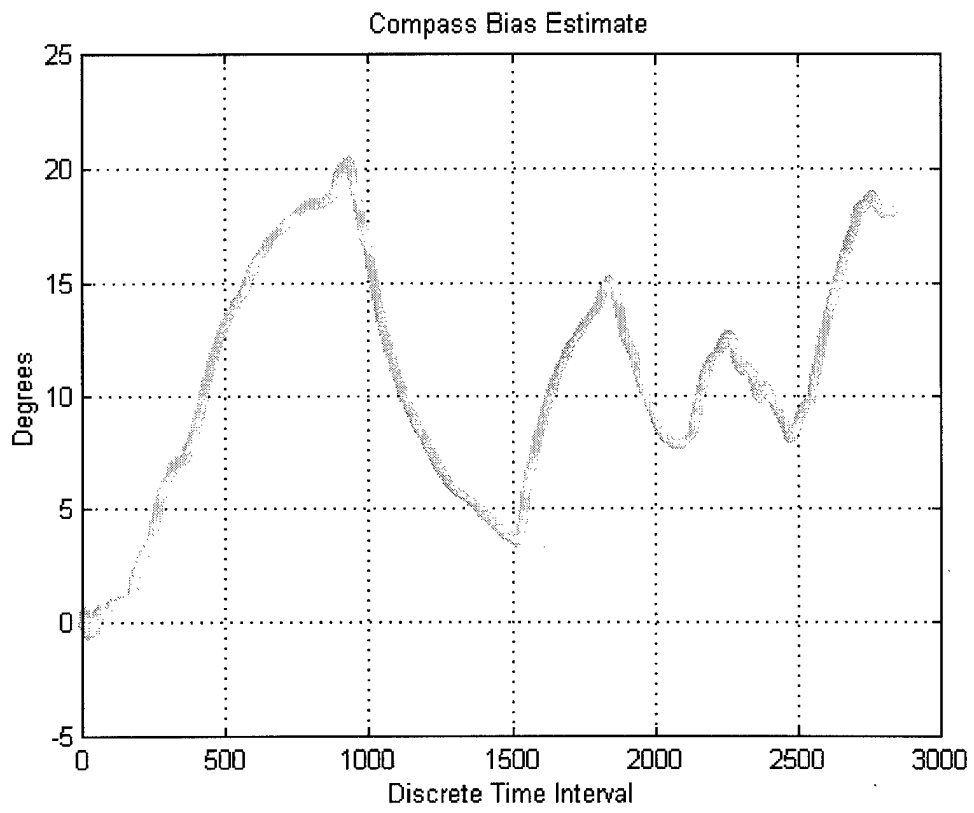

Figure 5.20: Filter Test #1 Compass Bias.

The heading plot not only compares the estimated heading with the compass heading, but it also demonstrates the “wrap” count method, which was previously discussed, and is not handled by the filter code data preprocessing. Even though the figure appears to show an almost exact match between the two heading plots, the compass bias plot shows that even though the trends are exactly the same, the compass and the filter values differ as much as 20.4° . This also shows that the filter is tracking the vehicle, and still has room for adjustments.

However, the yaw rate figure shows the IMU to be doing very well in its measurements. The yaw rate bias has a mean value of $4.3 \cdot 10^{-3}$ over the entire run. This can be considered negligible in light of the compass bias. Ideally, with low bias estimates for the compass and yaw rate, the error covariance of the state variables will be decreasing throughout the entire run. This decrease is simply due to the fact that the filter is learning what bias needs to be corrected in its next estimate. In Figure 5.21 you can see that the general trend in the first two elements of the error covariance, X and Y , is a decline in value. This plot specifically shows the error on X and Y in terms of the deviation σ_x^2 and σ_y^2 in m^2 .

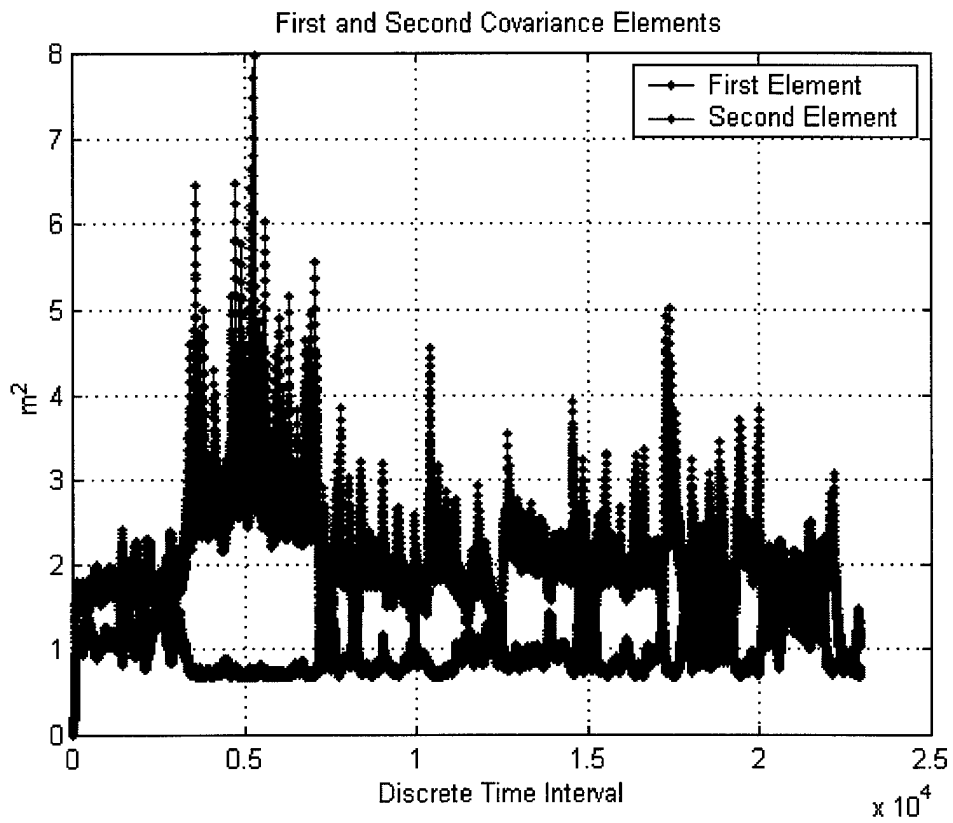

Figure 5.21: Filter Test #1 Covariance.

Decreasing error covariance shows that the filter is converging to a least squares solution. Likewise, the path plot shows that it also accurately tracks the vehicle. Because there is measurable bias between the filter's dead reckoned and DGPS solutions, the filter's output, the DGPS solution, can be considered more accurate than the output of a navigation system which uses only dead reckoning. However, the filter output is only better than dead reckoning when it receives the DGPS solution.

Since GPS satellite data does not travel underwater, the filter must rely on a dead reckoning solution when the GPS signal is no longer detectable. At this point the filter is as good as a dead reckoning system. But, it is now better than a system that uses only DGPS for navigation, because such a system cannot go underwater and simultaneously maintain an accurate position estimate. The second test, a dive test, shows an example of when the filter has to use the dead reckoning solution.

Before the dive, the filter learns bias information about the compass and gyro measurements. It uses these learned biases to help estimate the vehicle's position while it is underwater. When the AUV surfaces and begins taking DGPS fixes, the filter quickly corrects to the "true" solution from the dead reckoning solution it had been following. Figure 5.22 shows a segment of the dive run which exhibits this situation.

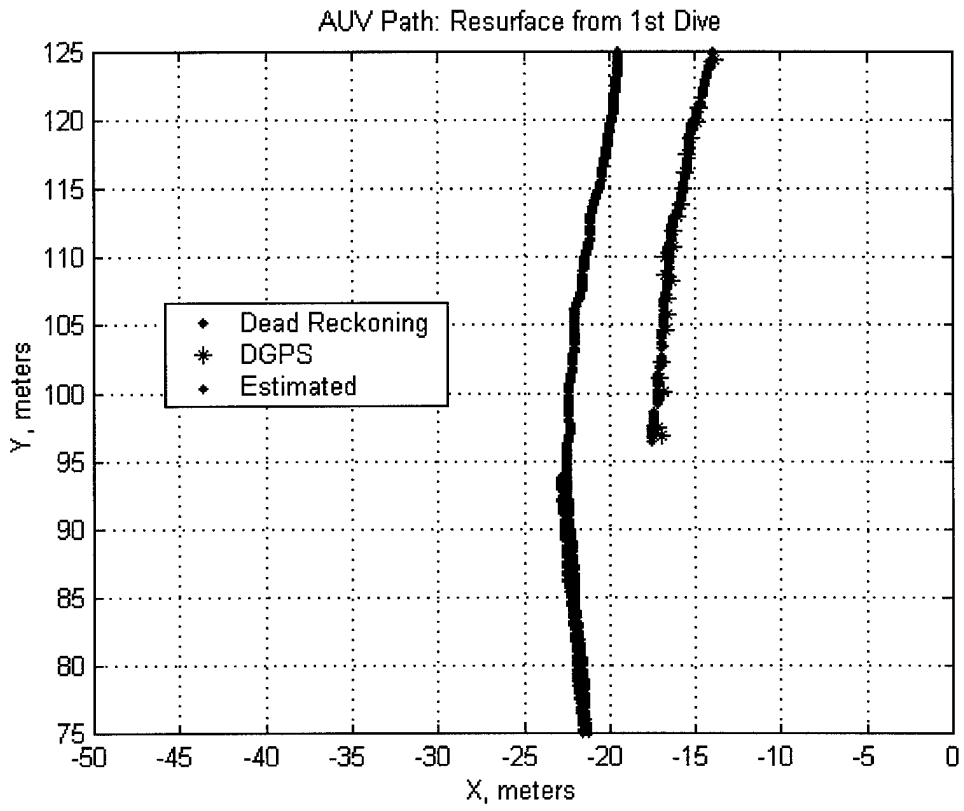

Figure 5.22: Filter Test #2 DGPS and Filter Track.

The vehicle has just surfaced from a dive, and finds it is 6m off from its estimated dead reckoning position. It immediately corrects to the DGPS position just before the beginning of the second dive. The 6m error in position is due to the fact that just before the AUV went under, it learned the bias for a heading 90° off from its intended heading. After it went underwater, the AUV did a corrected itself to drive on its intended path, which was a heading it had learned very little bias information about.

Surfacing after the second dive however, the vehicle finds it is much closer to where it thought it was. Without looking at the path plot, this fact is very obvious when viewing the covariance curves for the entire test, Figure 5.23. It shows areas of low covariance when the AUV is on the surface collecting DGPS data. However, as soon as DGPS is lost, the error begins steadily rising. The viewable difference is that the peak for the second dive is much smaller than the first, 655m² smaller.

On that same figure is a record of the vehicles altitude. By comparing the vehicles return to the surface with the drop in covariance, it is possible to see that the filter can correct its position as soon as it begins receiving DGPS signals. During this run, the time from surface to fix was 5.2 seconds.

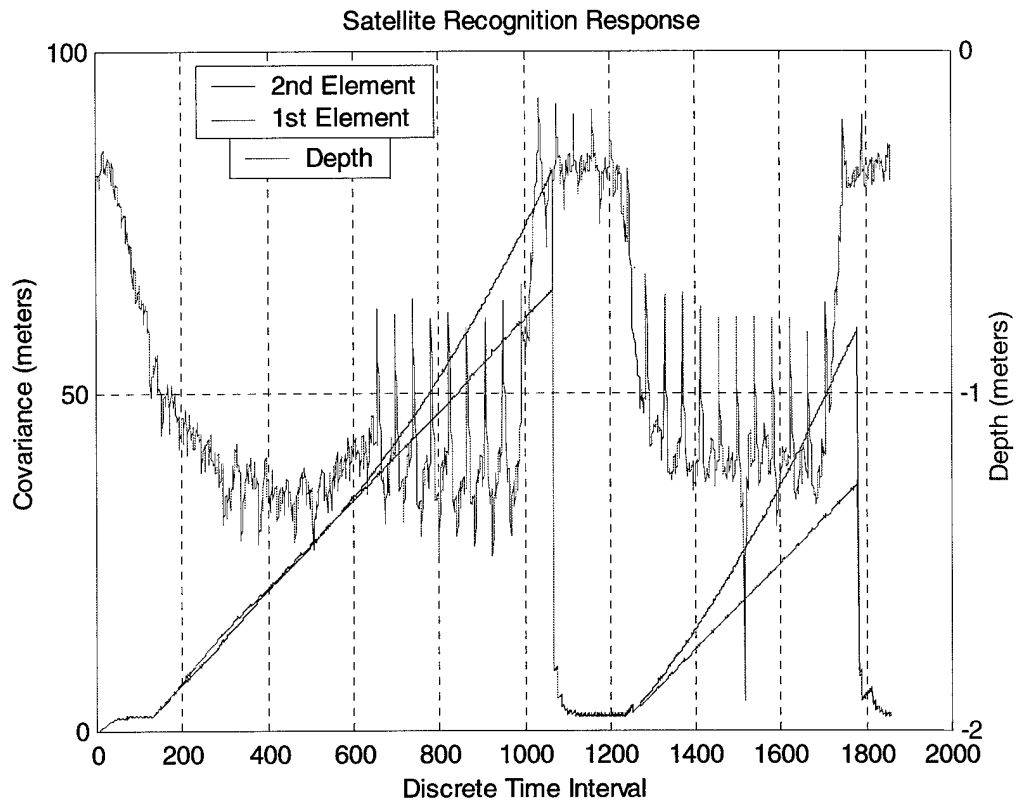

Figure 5.23: Filter Test #2 Covariance and Depth.

By analyzing the data from both filter tests, it may be easily stated that the ARIES Navigational Filter out performs any potential navigation system that operated using only DGPS or dead reckoning. Therefore the filter met the first objective set to qualify it in the ARIES AUV. Meeting the second objective will determine how accurate the filter's solution can be without the use of a DGPS signal.

2. Filter Adjustments

This final section of results will examine a study on the effects of adjusting the properties within the filter to enhance its performance. The set objective for these adjustments is to increase the vehicle's accuracy of position estimation at the end of powered dive runs. This objective can theoretically be met by adjusting the speed and precision the filter uses to predict and correct the vehicle's state. The filter's speed and precision can be changed by changing the values of the gains which govern the Q and R matrices previously discussed in chapter 4.

The data used during this study is composed of two separate dive tests conducted by the ARIES. One test involves the ARIES making five powered dives along on continuous path, which it was towed around between dives. The other data set tracks the AUV as it makes a dive under vehicle propulsion, which was immediately followed by a powered surface run, and then another powered dive. These two data sets were selected for two specific reasons.

First, the data used to adjust the filter properties must contain dive exercises. It is necessary to examine a dive to ensure the filter attains the most accurate position estimation possible when the vehicle surfaces. Additionally, because one data set

involves the vehicle being towed, and the second tracks the vehicle entirely under its own propulsion, together the data sets are different enough to provide an objective test of the filter results. The results however, were specifically examined according to the changing gain values and not the data sets.

The first step was to narrow down the numerical region of gains to be tested. The initial values for the gains were as follows:

$$Q = \begin{bmatrix} 0 \dots 0 \dots 0 & 0 & 0 & 0 & 0 \dots 0 \\ 0 & 0 & 0 & 0 & 0 & 0 & 0 & 0 \\ 0 & 0 & 1E^{-2} & 0 & 0 & 0 & 0 & 0 \\ 0 & 0 & 0 & 1E^{-2} & 0 & 0 & 0 & 0 \\ 0 & 0 & 0 & 0 & 1E^{-1} & 0 & 0 & 0 \\ 0 & 0 & 0 & 0 & 0 & 1E^{-1} & 0 & 0 \\ 0 & 0 & 0 & 0 & 0 & 0 & 0 & 0 \\ 0 & 0 & 0 & 0 & 0 & 0 & 0 & 1E^{-6} \end{bmatrix} *G_Q$$

$$R = \begin{bmatrix} 1E^{-2} & 0 & 0 & 0 & 0 & 0 \\ 0 & 1E^{-2} & 0 & 0 & 0 & 0 \\ 0 & 0 & 1E^{-3} & 0 & 0 & 0 \\ 0 & 0 & 0 & 1E^{-3} & 0 & 0 \\ 0 & 0 & 0 & 0 & 1E^{-1} & 0 \\ 0 & 0 & 0 & 0 & 0 & 1E^{-1} \end{bmatrix} *G_R$$

In these equations, G_Q is 1 and G_R is 1000, originally. To narrow down the possible options for gain adjustments, G was changed by powers of ten, for the vehicle run which was entirely under power, to decide which power of ten yielded the best results. The geographic plot for the data set, using the original gains may be viewed as Figure 5.24.

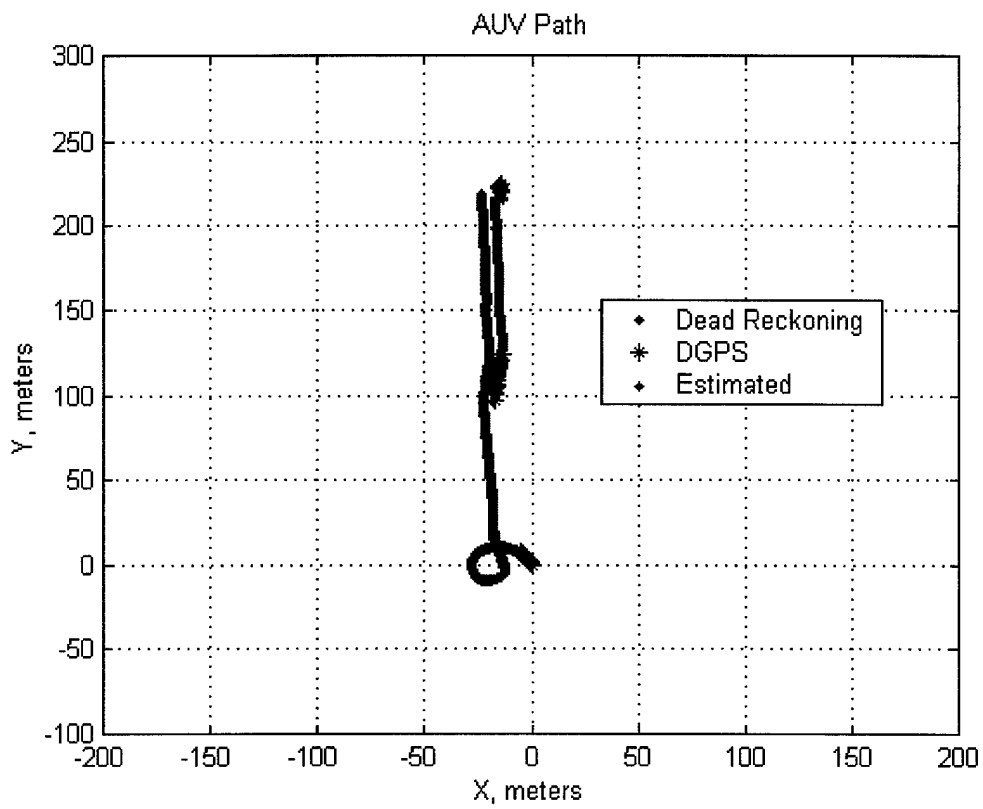

Figure 5.24: Gain Test Data Set #2 DGPS and Original Filter Track.

Table 5.6 below shows the results changing the gain had on the positional accuracy of the plot. This result occurs, due to the fact that the higher the values of the R matrix, the more system noise the filter considers present in the measurement model. Therefore, with more noise present, the filter does not “filter” as much, because it has a reduced sensitivity to small changes in the data.

R Gain	Q Gain	Position Error (m)
1000	1	2.00
100	1	0.83
75	1	0.56
50	1	0.10
25	1	0.92
10	1	1.83
1	1	2.50

The “Position Error” is the linear distance between the filter’s estimated position at the point of the vehicle’s resurface from the second dive, and the first DGPS fix. This data shows that the ideal range for the R matrix gain is between 10 and 100 to continue pursuing continuous sub-meter accuracy. The next test, similar to the first, measures the results that occur do to changes in the value of the Q matrix gain.

This analysis was conducted using the data from the 5 dive test, with towing in between due to the extensive vehicle path. A more extensive path makes greater use of the RDI compass, and since the Q matrix governs the speed of the filter, it is directly related to the bias measurement. A higher gain value should run the filter faster, and therefore identify a higher bias value, perhaps to the point of over correction. The original path plot of this dive test can be seen as Figure 5.25.

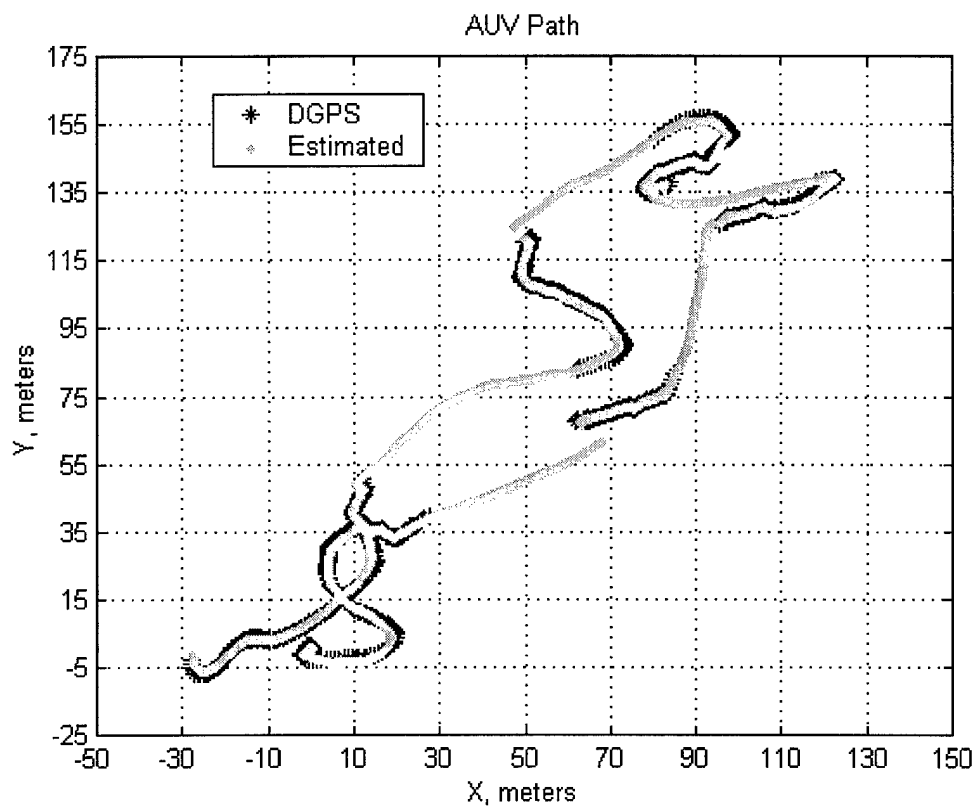

Figure 5.25: Gain Test Data Set #1 DGPS and Original Filter Track.

The results of the analysis, seen in Table 5.7 below, show yet another narrowing of the possible filter options. The position error, which is a sum of the position errors for all 5 dives, and the max compass bias, which is the absolute range of compass bias, show that the best combined results occur when the Q gain is between 1 and 0.1. When the gain is between this region it has the lowest error, and the compass bias is still measured precisely, but found to be relatively low.

R Gain	Q Gain	Position Error (m)	Max ψ Bias
100	100	28.68	19.35
100	10	27.15	11.51
100	1	17.21	7.33
100	0.75	18.60	6.87
100	0.5	16.66	6.11
100	0.1	19.33	3.61
100	0.01	28.29	2.46

Therefore the next analysis combines the gains values of 100, 50 and 10 for use with the R matrix, and 1, 0.5, and 0.1 for use with the Q matrix. Each combination was compared for positional accuracy and the amount of measured compass bias. Those results yielded obvious trends, which indicate the R gain of 50 performs the best with all three Q gain values. However, the results from within the different Q gains differed little. The only noticeable difference followed the general trend that a lower Q gain will identify a lower range of compass bias. Table 5.8 shows this trend.

TABLE 5.8: Final Gain Test Results				
<i>R</i> Gain	<i>Q</i> Gain	Position Error (m) Data #1 & #2	Max ψ Bias	
50	1	0.10	18.13	8.62
50	0.5	0.42	18.21	7.49
50	0.1	0.67	19.33	3.61

As a result, the final gains chosen for the filter, was the *R* gain value of 50, and the *Q* gain value of 1. The plotted results of this choice for data set #1 can be seen Figure 5.26. The reason the *Q* gain with the lower compass bias was not selected as default, was because position error holds a higher priority towards the success of ARIES AUV and its missions.

These tests show without a doubt, that by adjusting the properties of the filter, its performance can be enhanced. It is also visible from the results, that on longer underwater runs, such as it is with data set #1, the position error can be corrected to sub-meter values. These corrections will allow the vehicle to progressively expand its navigational ability. Ideally, shorter runs and runs with more complicated underwater maneuvers will also be able to create surface worthy positional accuracy on largely submerged paths.

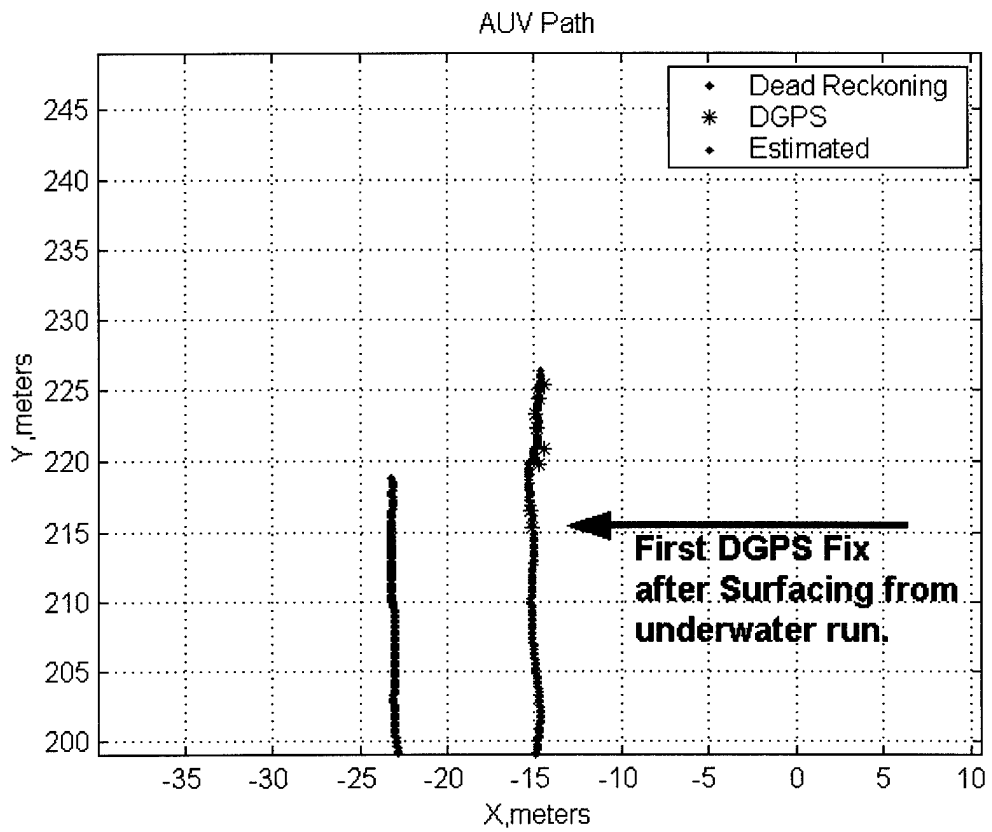

Figure 5.26: Gain Test Data Set #1 DGPS and Tuned Filter Track.

THIS PAGE INTENTIONALLY LEFT BLANK

VI. CONCLUSIONS AND RECOMMENDATIONS

A. CONCLUSIONS

As AUVs continue to become a better option for ocean data gathering operations, research will continue to strive for their improved performance, and those who use them will strive to decrease their cost. There will always be a reason to enhance the methods used for underwater positioning in almost any underwater field of study. The continued development and evaluation of "small, low power, low cost" underwater Navigational Suite will always be of interest. Therefore the experimental configuration and evaluation of one such system for the ARIES AUV has been the focus of this work.

Through a progressive series of testing, this work has shown that the ARIES DGPS based Navigation Suite is capable of providing a solution for the vehicle's position with sub-meter precision. This precision has been obtained for relatively short dives (200-300m underwater runs) using a properly tuned EKF. Additionally, it has been found that only a 2-5sec delay occurs for the reacquisition of GPS satellite signals after surfacing. This minimal amount of time allowed the Suite to quickly "learn" and adjust from sensor bias errors.

B. RECOMMENDATIONS

Based on the results of this thesis and the research required to complete it, an initial recommendation should be made to continue the study of DGPS/IMU/Doppler navigation. With further time and experimentation, the Suite can be relied on more heavily for more complex future, underwater operations. Based on its ability to

effectively position the vehicle, operations, which will allow the vehicle to locate and examine underwater features and targets such as in mine countermeasure operations or ocean floor studies, could now be accomplished with a higher proficiency. Attention should also continue to be given to the technology used within the Suite. As positioning becomes a greater interest in the underwater arena, as well as the automotive and forestry industry, better technology will become available for less, as the “cost/accuracy curve” decreases. [Ref. 3] This trend should be fully utilized, to aide in research such as this.

There is also a growing need to introduce an Acoustic modem to the ARIES platform. With its accurate navigational system in place, it is ready to take on the role of a mobile server for communicating with other AUVs. This idea, suggested for the ARIES by Prof. Anthony J. Healey, would use one vehicle as a server to provide position information, and “mission reconfigurable commands.” “Multi-vehicle Networks”, have the potential to be very useful to the mine countermeasure community in the U.S. Navy as well. Allowing fleets of AUVs, all communicating through a server vehicle, to clear paths for Navy surface ships or Marine amphibious units, could save a lot of time, money, and personnel.

APPENDIX A: NMEA MESSAGE FORMAT [Ref. 5]

This appendix identifies the selection of NMEA 0183 command and status query messages valid for the ABX-3. The latest version is available by contacting:

National Marine Electronics Association
NMEA Executive Director
P. O. Box 50040, Mobile, Alabama 36605, USA
Tel (205) 473-1793 Fax (205) 473-1669

Information on the RTCM SC104 format is available at:

Radio Technical Commission for Maritime Services
Post office Box 19087
Washington, DC 20036

NMEA MESSAGE ELEMENTS

All NMEA 0183 messages possess a common structure, including a message header, data fields, and a terminating carriage return and line feed.

Example: \$GPYYY,xxx,xxx,xxx ... <CR><LF>

The table below displays the elements of this example message.

Element	Description
\$GP	Message Identifier Indicating a GPS Related Message
Yyy	Type of GPS Message
Xxx	Variable Length Message Fields
<CR>	Carriage Return
<LF>	Line Feed

ABX-3 SUPPORTED MESSAGES

The ABX-3 supports the NMEA commands and queries listed in the following Table.

Message description	Description
Commands	
\$GPMSK (Full Manual Tune)	Sets the receiver into Full Manual Tune Mode
\$GPMSK (Partial Manual Tune)	Sets the receiver into Partial Manual Tune Mode
\$GPMSK (ABS Mode)	Sets the receiver into Automatic Beacon Search Mode
\$PCSI,4 (Proprietary)	Erases the Global Search table forcing a new search
\$PCSI,5 (Proprietary)	Sets the baud rate of the ABX-3 communication port
\$PCSI,6 (Proprietary)	Reserved
\$PCSI,7 (Proprietary)	Reserved
\$PSLIB (Proprietary)	Sets the frequency and MSK bit rate of the ABX-3
Queries	
\$GPCRQ Operation Query	Queries the receiver for operation parameters
\$GPCRQ Performance Query	Queries the receiver for performance parameters
\$PCSI,0 (Proprietary)	Lists available proprietary \$PCSI commands and queries
\$PCSI,1 (Proprietary)	Displays receiver operating parameter status
\$PCSI,2 (Proprietary)	Queries the receiver for operation parameters
\$PCSI,3 (Proprietary)	Outputs receiver search information

NMEA 0183 COMMANDS

This section discusses the standard and proprietary NMEA 0183 commands accepted by the ABX-3.

- **Full Manual Tune Command (\$GPMSK)**

This command instructs the ABX-3 to tune to a specified frequency and MSK Rate. It has the following form:

\$GPMSK,fff.f,M,ddd,M,n<CR><LF>

- **Partial Manual Tune Command (\$GPMSK)**

This command instructs the ABX-3 to tune to a specified frequency and automatically select the correct MSK rate. It has the following form:

\$GPMSK,fff.f,M,,A,n<CR><LF>

- **Automatic Beacon Search Command (\$GPMSK)**

This command initiates the ABX-3 automatic mode of operation in which the receiver operates without operator intervention, selecting the most appropriate beacon station. This command has the following format:

\$GPLMSK,,A,,A,n<CR><LF>

- **Wipe Search Command (\$PCSI,4)**

The Wipe Search command instructs the ABX-3 to erase all parameters within the beacon almanac and to initiate a new Global Search to identify the beacon signals available for a particular area. The command has the following form:

\$PCSI,4<CR><LF>

- **Baud Rate Change Command (\$PCSI,5)**

This proprietary \$PCSI command is reserved for use with the ABX-3.

\$PCSI,5,r<CR><LF>

- **Tune Command (\$PSLIB)**

A majority of Garmin hand-held and fixed-mount GPS receivers output this non-standard command from the BEACON RCVR feature of the INTERFACE menu. It instructs both the connected beacon receiver to tune to the specified frequency and MSK Rate. The command has the following form:

\$PSLIB,fff.f,ddd<CR><LF>

NMEA 0183 QUERIES

This section discusses the standard and proprietary NMEA 0183 queries accepted by the ABX-3 receiver.

- **Receiver Operating Status Query (\$GPCRQ)**

This standard NMEA query prompts the ABX-3 receiver for its operational status. It has the following format:

\$GPCRQ,MSK<CR><LF>

- **Receiver Performance Status Query (\$GPCRQ)**

This standard NMEA query prompts the ABX-3 receiver for its performance status:

\$GPCRQ,MSS<CR><LF>

- **Receiver Help Query (\$PCSI,C)**

This command queries the ABX-3 receiver for a list of valid proprietary \$PCSI commands:

\$PCSI,0<CR><LF>

- **ABX-3 Status Line A, Channel 0 (\$PCSI,1)**

This commands the ABX-3 to output a selection of parameters related to the operational status of its primary channel. It has the following format:

\$PCSI,1<CR><LF>

- **ABX-3 Status Line B, Channel 1 (\$PCSI,2)**

This commands the ABX-3 to output a selection of parameters related to the operational status of its secondary channel. It has the following format:

\$PCSI,2<CR><LF>

- **Receiver Search Dump (\$PCSI,3)**

This query commands the ABX-3 to display the search information used for beacon selection in Automatic Beacon Search mode. The output has three frequencies per line.

\$PCSI,3<CR><LF>

APPENDIX B: *MATLAB* CODE ASSOCIATED WITH ANALYSIS OF INITIAL GPS EVALUATION

Basic GPS Analysis:

```
% B.M. STINESPRING
% GPS DATA PLOTTING PROG
clc
format long
clear
load GPS021100_2POS.d

% IDENTIFICATION
GPS=GPS021100_2POS;
GPS_ID=GPS(:,1);
LatDeg=GPS(:,2);
LongDeg=GPS(:,3);
Diff=GPS(:,4);
NumSats=GPS(:,5);
Time=GPS(:,6);
Lat=GPS(:,7);
Long=GPS(:,8);
Altit=GPS(:,9);
TruTrac=GPS(:,10);
SOG=GPS(:,11);
VertVel=GPS(:,12);
PDOP=GPS(:,13);
HDOP=GPS(:,14);
VDOP=GPS(:,15);
TDOP=GPS(:,16);

% DATA SEPARATION

Data=[LatDeg,LongDeg,NumSats,PDOP,HDOP,VDOP,TDOP,Diff,GPS_ID];
P=length(Data);
n=0;
for R=1:P;
    T=R-n;
    if Data(R,2)~=0;
        Pos(T,:)=Data(R,:);
    else
        n=n+1;
    end
end
k=0;
```

```

U=length(Pos);
for S=1:U;
    U=S-k;
    if Pos(S,8)==1;
        Pos_diff(U,:)=Pos(S,:);
    else
        k=k+1;
    end
end
Q=length(Pos_diff);
Dop_average=mean(Pos_diff(:,4))
Dop_max=max(Pos_diff(:,4))
NumSats_average=mean(Pos_diff(:,3))
Number_of_recorded_entries=P
Number_of_fixes=U
Number_of_fixes_with_Diff=Q
Number_of_unusable_recorded_data=P-Q
Percent_of_usable_data=(Q/P)*100

Geo(:,1)=Pos_diff(:,1)-(min(Pos_diff(:,1)));
Geo(:,2)=Pos_diff(:,2)-(min(Pos_diff(:,2)));
Geo(:,3)=transpose(1:(length(Geo)));

% MANIPULATION

lambda=(36.6)*(pi/180);
Lat_meters=(Geo(:,1)).*(60*1852);
Long_meters=(Geo(:,2)).*(60*1852*(cos(lambda)));

% Plots

figure(1);
plot(Long_meters,Lat_meters,'-bs','LineWidth',1,...
      'MarkerEdgeColor','k',...
      'MarkerFaceColor','r',...
      'MarkerSize',3)
xlabel('<-- West (meters) East -->')
ylabel('<-- South (meters) North -->')
grid
title('Geographic Plot of GPS Track');
Fin=[Lat_meters,Long_meters,Pos_diff(:,9)];
A=Fin(1,2);
B=Fin(1,1);
C=Fin((length(Fin)),2);
D=Fin((length(Fin)),1);
text(A,B,'\leftarrow Start','FontSize',8)

```

```

text(C,D,'leftarrow Finish','FontSize',8)
a=Pos_diff(:,9);
for b=1:length(a);
    c=Fin(b,2);
    d=Fin(b,1);
    plot_text=num2str(a(b));
    text(c,d,plot_text);
end;

```

```

figure(2);
E=Pos_diff(:,3);
F=2:1:10;
hist(E,F);
title('Satelite Frequency (Open Water)')
xlabel('Number of Satelites')
ylabel('Frequency')
grid;

```

```

figure(3)
G=transpose(1:Q);
plot(G,Pos_diff(:,4),G,Pos_diff(:,5),...
    G,Pos_diff(:,6),G,Pos_diff(:,7))
legend('PDOP','HDOP','VDOP','TDOP');
title('DOP vs Interval (Open Water)')
grid

```

```

figure(4)
subplot(3,1,1), bar(GPS_ID,NumSats),grid,colormap summer;
ylabel('Number of Sats');
subplot(3,1,2),
plot(GPS_ID,PDOP,GPS_ID,HDOP,GPS_ID,VDOP,GPS_ID,TDOP),grid;
legend('PDOP','HDOP','VDOP','TDOP');
subplot(3,1,3), bar(GPS_ID,Diff),grid,colormap jet;
ylabel('Differential Signals');

```

```

figure(5)
plot(Long_meters,Lat_meters,'-bs','LineWidth',1,...
    'MarkerEdgeColor','r',...
    'MarkerFaceColor','r',...
    'MarkerSize',2)
xlabel('<-- West (meters) East -->')
ylabel('<-- South (meters) North -->')
grid
title('Geographic Plot of GPS Track (Open Water)');
Fin=[Lat_meters,Long_meters,Pos_diff(:,9)];

```

```

A=Fin(1,2);
B=Fin(1,1);
C=Fin((length(Fin)),2);
D=Fin((length(Fin)),1);
text(A,B,'\leftarrow Start','FontSize',8)
text(C,D,'\leftarrow Finish','FontSize',8)
legend('DGPS Fix on AUV Track');

```

```

figure(6)
horz=Fin(143:164,2);
vert=Fin(143:164,1);
[P,S]=polyfit(horz,vert,1);
[Y,Delta]=PolyVal(P,horz,S);
Standard_Deviation_of_Error=std(Delta)
Mean_of_Error=mean(Delta)
plot(horz,vert,'*',horz,Y,'-')
axis([-4,-3,2,9]);
legend('Data Points','Linear Regression')
title('Linear Regression Plot')
xlabel('<-- West (meters) East -->')
ylabel('<-- South (meters) North -->')
Finny=Fin(143:164,:);
aa=Finny(:,3);
for bb=1:length(horz);
    cc=Finny(bb,2);
    dd=Finny(bb,1);
    plott_text=num2str(aa(bb));
    text(cc,dd,plott_text);
end;

```

APPENDIX C: *MATLAB* CODE ASSOCIATED WITH ARIES NAVIGATIONAL FILTER

1st File for Variable Assignment:

```
Nav_Id = Nav(:,1);
Hour   = Nav(:,2);
Minute = Nav(:,3);
Second = Nav(:,4);
MP_Id  = Nav(:,5);
MP_p   = Nav(:,6);
MP_q   = Nav(:,7);
MP_r   = Nav(:,8);
MP_XAccel = Nav(:,9);
MP_YAccel = Nav(:,10);
MP_ZAccel = Nav(:,11);
RDI_Id  = Nav(:,12);
RDI_Ug  = Nav(:,13);
RDI_Vg  = Nav(:,14);
RDI_Wg  = Nav(:,15);
RDI_Uf  = Nav(:,16);
RDI_Vf  = Nav(:,17);
RDI_Wf  = Nav(:,18);
RDI_Alt = Nav(:,19);
RDI_Heading = Nav(:,20);
GPS_Id  = Nav(:,21);
Diff    = Nav(:,22);
NSv     = Nav(:,23);
ToC     = Nav(:,24);
Lat     = Nav(:,25);
LatDeg  = Nav(:,26);
Long    = Nav(:,27);
LongDeg = Nav(:,28);
SbA     = Nav(:,29);
TtTc   = Nav(:,30);
SoG     = Nav(:,31);
Vv      = Nav(:,32);
Pdop    = Nav(:,33);
Hdop    = Nav(:,34);
Vdop    = Nav(:,35);
Tdop    = Nav(:,36);
DepthRaw = Nav(:,37);
Depth   = Nav(:,38);
Depth_dot = Nav(:,39);
```

2nd File for Variable Assignment:

```
clear
clc
load d033000_05.d
(where d033000_05.d is a data file)
d=d033000_05;
```

```
State_Id = d(:,1);
Nav_Id   = d(:,2);
t        = d(:,3);
X        = d(:,4);
Y        = d(:,5);
Depth    = d(:,6);
Alt      = d(:,7);
phi      = d(:,8);
theta    = d(:,9);
psi      = d(:,10);
u        = d(:,11);
v        = d(:,12);
Depth_dot = d(:,13);
Alt_dot  = d(:,14);
p        = d(:,15);
q        = d(:,16);
r        = d(:,17);
n_ls     = d(:,18);
n_rs     = d(:,19);
n_bvt    = d(:,20);
n_svt    = d(:,21);
n_blt    = d(:,22);
n_sl     = d(:,23);
delta_r  = d(:,24);
delta_sp = d(:,25);
```

Basic Navigational Filter File:

```
% Navigation Filter
% For ARIES AUV Navigation Data

clear
clc
load d033000_04.d
```

```

assign

% Assign Y matrix from "assignNav" output
y=[u,v,psi,r,X,Y];

% Define Filter variables
ug=y(:,1);
vg=y(:,2);
heading=y(:,3);
yaw_rate=y(:,4);
lat=y(:,5);
long=y(:,6);
wg=Depth_dot;

%%%%%%%% Defining Sample Size %%%%%%%%%
startSample=1;
endSample=length(ug);

%%%%%%%% Converting the Lat and Long Data %%%%%%%%%
long=long*60*3600*.51*0.80;
l1=long(startSample);

lat=lat*60*3600*.51;
l2=lat(startSample);

long=long-l1.*ones(length(lat),1);
lat=lat-l2.*ones(length(lat),1);

%%%%%%%% Setting the Time base %%%%%%%%%
dt=.1235;
t=0:dt:(length(ug)-1)*dt;
%t=0:.125:((length(yaw_rate)-1)/8);

%%%%%%%% Adjusting Heading for 360 degree wrapping %%%%%%%%%
nheading = zeros(1, length(heading));
nheading(1) = heading(1);
for i=2:length(heading)
    if abs(heading(i) - heading(i-1)) <= 180
        nheading(i) = nheading(i-1) + heading(i) - heading(i-1);
    end
    if heading(i) - heading(i-1) > 180
        nheading(i) = nheading(i-1) + heading(i) - heading(i-1) - 360;
    end
    if heading(i-1) - heading(i) > 180

```

```

    nheading(i) = nheading(i-1) + heading(i) - heading(i-1) + 360;
end
end

```

```

heading = ((nheading')-18)*(pi/180)+2*pi; %Must be in radians

```

```

%%%%%%%% Defining Y(1,2,3,5,6) %%%%%%%%%
y=[ug,vg,heading,yaw_rate,lat,long];

```

```

%%%%%%%% Initializing the Loop %%%%%%%%%
psi0=mean(heading(startSample:startSample+15));
%iniialize the state vector,x is 8,y is 6
x=zeros(8,endSample);err=zeros(6,endSample);
s=startSample,
endSample
x(:,s)=[lat(s),long(s),psi0,yaw_rate(s),ug(s),vg(s),0,0]';
w=1;

```

```

%MANEUVERING AND CURRENT TIME CONSTANTS

```

```

%Initial A matrix
A=zeros(8,8);
X=x(1,s);Y=x(2,s);psi=x(3,s);r=x(4,s); dop_ug=x(5,s);dop_vg=x(6,s);
br=x(7,s);bpsi=x(8,s);
A(1,3)=-dop_ug*sin(psi)-dop_vg*cos(psi);
A(1,5)=cos(psi);
A(1,6)=-sin(psi);
A(2,3)=dop_ug*cos(psi)-dop_vg*sin(psi);
A(2,5)=sin(psi);
A(2,6)=cos(psi);
A(3,4)=1;

%A(8,4)=0.1;
% x(:,s)=[lat(s),long(s),psi0,yaw_rate(s)*pi/180,dop_ug(s),dop_vg(s),br,bpsi]';
% y=[ug,vg, compass, yawrate,gpsX, gpsY}

```

```

%Initial C matrix
%yaw_rate=r+br;
%heading=psihat+bpsi;
C=zeros(6,8);
C(1,5)=1;
C(2,6)=1;
C(3,3)=1;C(3,8)=1;

```

```

C(4,4)=1;C(4,7)=1;
C(5,1)=1;C(6,2)=1;

%Initial B matrix
q1=0;%variance on X, m^2
q2=0;%variance on Y, m^2
q3=0.001;%variance on psi, rad^2
q4=0.001;% variance on r, rad/s)^2% 0.01 is normal
q5=0.01;% variance on ug,(m/s)^2
q6=0.01;% variance on vg,(m/s)^2
q7=0.000001;
q8=0.000001;

B=[q1;q2;q3;q4;q5;q6;q7;q8];
%B=[0;0;0;0;0;0;0;0];
Q=diag(B);

%system noise
%nu1=.01;nu2=.01;nu3=.1;nu4=0.001;nu5=1.0;nu6=1.0;
nu1=.01;nu2=.01;nu3=0.1;nu4=0.001;nu5=1.0;nu6=1.0;
gnu=[nu1;nu2;nu3;nu4;nu5;nu6]*10;
R=diag(gnu); % measurement noise
psave=zeros(8,endSample);
%Note, old_after means measured data at old time, new_before means model predicted
value
%load old;

p_old_after=diag([0.1 .1 .1 .1 .1 .1 .001 .001])/10;
delx_old_after=zeros(8,1);
g=ones(8,1);
p_old_after(8,8)=0.01;
for i=startSample:(endSample-1);
    %compute linearized PHI matrix using updated A
    phi=expm(A*dt);
    %reset initial state
    x_old_after=x(:,i);
    % nonlinear state propagation
    [x_new_before]=prop8_new(x_old_after,0,0,dt,0);
    %error covariance propagation
    p_new_before=phi*p_old_after*phi' + Q;
    %new gain calculation using linearized new C matrix and current state
    %error covariances.
    %formulate the innovation using nonlinear output propagation
    %as compared to new sampled data from measurements
    yhat=output8_new(x_new_before);
    err(1:6,i+1)=(y(i+1,1:6)' - yhat);

```

```

% Restrictions on C
if sqrt(err(5,i+1)^2+err(6,i+1)^2)>1000,
    err(5,i+1)=0;err(6,i+1)=0;
end;
if y(i+1,1)==y(i,1),C(1,:)=0.0*g';end;
if (abs(y(i+1,1)))>10,C(1,:)=0.0*g';end;
if y(i+1,2)==y(i,2),C(2,:)=0.0*g';end;
if (abs(y(i+1,2)))>10,C(2,:)=0.0*g';end;
if y(i+1,3)==y(i,3),C(3,:)=0.0*g';end;
if y(i+1,4)==y(i,4),C(4,:)=0.0*g';end;

%%%%%% GPS RESTRICTIONS %%%%%%
% timed fixes (take GPS fixes for 10 seconds every 3 min)
%p=[startSample:1440:1E6];
%f=p(w);
%v=i-f;
%if v==1440;w=w+1;end
%if v>=80;C(5,:)=0.0*g';C(6,:)=0.0*g';
%else C(5,1)=1;C(6,2)=1;end

% heading triggered fixes (take GPS fix for 90 degree change)
%k=(abs(y(i+1,3)-y(i,3)));
%if k>=(pi/1000);C(5,1)=1;C(6,2)=1;end;
%if i<=1000, C(5,1)=1;C(6,2)=1;end;
%if i>1000, C(5,:)=0.0*g';C(6,:)=0.0*g';end;
%if i>=1200, C(5,1)=1;C(6,2)=1;end;
if y(i+1,5)==y(i,5),C(5,:)=0.0*g';end;
if y(i+1,6)==y(i,6),C(6,:)=0.0*g';end;

%eliminate dgps input
cpc=C*p_new_before*C'+R;
rel(:,i+1)=err(:,i+1)*inv(cpc)*err(:,i+1);
% compute gain, update total state and error covariance
G=p_new_before*C'*inv(C*p_new_before*C' + R); % Kalman Gain
p_old_after=[eye(8) - G*C]*p_new_before;
psave(:,i+1)=diag(p_old_after);
%if gpsStatus(i+1)~=2, G=zeros(8,6);end;
x_new_after=x_new_before + G*err(:,i+1);
%carry new state into next update
x(:,i+1)=x_new_after;

%resetting up the linearized A matrix
A=zeros(8,8);

```

```

X=x(1,i+1);Y=x(2,i+1);psi=x(3,i+1);r=x(4,i+1);
dop_ug=x(5,i+1);dop_vg=x(6,i+1);br=x(7,i+1);bpsi=x(8,i+1);
A=zeros(8,8);
A(1,3)=-dop_ug*sin(psi)-dop_vg*cos(psi);
A(1,5)=cos(psi);
A(1,6)=-sin(psi);
A(2,3)=dop_ug*cos(psi)-dop_vg*sin(psi);
A(2,5)=sin(psi);
A(2,6)=cos(psi);
A(3,4)=1;

%A(8,4)=0.1; %reset the linearized C matrix
C=zeros(6,8);
C(1,5)=1;
C(2,6)=1;
C(3,3)=1;C(3,8)=1;
C(4,4)=1;C(4,7)=1;
C(5,1)=1;C(6,2)=1;
end;
%%%%%%%%% DEAD-RECKONING SOLUTION GENERATION %%%%%%%%%%

Xdr=zeros(1,length(t));Ydr=Xdr;psi2=Xdr;psi2(startSample)=heading(startSample);
for i=startSample:(endSample-1),
    bias=0.487551550379541e-002;
    %bias=x(7,i-1);
    psi2(i+1)=psi2(i)+(yaw_rate(i)-bias)*0.1235;
    %ppsi=heading(i)*pi/180-20*cos(heading(i)).*pi/180; %-x(8,i);
    %if t(i)>520; ppsi=heading(i)*pi/180+4*pi/180;end;
    %ppsi=psi2(i);
    ppsi=heading(i); %%%%%%%%%%
    pphi=0; %phi1(i); %MP_YAccel(i)/9.81;
    pth=0; %theta(i); %MP_XAccel(i)/9.81;
    if (abs(y(i,1)))>10,ug(i)=ug(i-1);end;
    if (abs(y(i,2)))>10,vg(i)=vg(i-1);end;

    f1(i)=ug(i)*cos(ppsi)*cos(pth)-vg(i)*(sin(ppsi)*cos(pphi)...
        +cos(ppsi)*sin(pth)*sin(pphi))+sin(ppsi)*sin(pphi)*wg(i);

    f2(i)=ug(i)*sin(ppsi)*cos(pth)+vg(i)*(cos(ppsi)*cos(pphi)+sin(ppsi)*sin(pth)*sin(pphi))-
        cos(ppsi)*sin(pphi)*wg(i);

    Xdr(i+1)=Xdr(i)+0.1235*(f1(i));
    Ydr(i+1)=Ydr(i)+0.1235*f2(i);

```

```

end;

figure(1),clf
plot(t(startSample:endSample),x(3,startSample:endSample)*180/pi,'y.',...
     t(startSample:endSample),y(startSample:endSample,3)*180/pi,'g',...
     t(startSample:endSample),psi2(startSample:endSample)*180/pi,'r.'),grid

title('FIGURE 1 est. heading,y, compass, g')
%plot(heading,'g'),grid
title('FIGURE 1 est. heading,y, compass, g')
zoom

figure(2),clf
plot(y(startSample:endSample,6),y(startSample:endSample,5),'bo'),grid
hold on
plot(x(2,startSample:endSample),x(1,startSample:endSample),'g.')
plot(Ydr(startSample:endSample),Xdr(startSample:endSample),'y.')
title('Figure 2 Estimated Path, g , DGPS Data, c Dead Reckoning, y ')
xlabel('X, meters');ylabel('Y, meters');axis([-100 200 -100 200]);
hold off
zoom

figure(3)
plot(t(startSample:endSample),x(7,startSample:endSample),'g'),grid
hold
%plot(t(startSample:endSample),x(9,startSample:endSample),'r.')
title('r bias estimate, g')
hold off
zoom

figure(4)
plot(t(startSample:endSample),x(8,startSample:endSample)*180/pi,'g.'),grid
title('compass bias estimate, g.')

figure(5) %doppler u
plot(t(startSample:endSample),ug(startSample:endSample),'y+',...
     t(startSample:endSample),x(5,(startSample:endSample)), 'c*'),grid
title('Doppler u, + and estimated u, * vs Time sec')
zoom

figure(6)
plot(psave(1,:),'-');hold;plot(psave(2,:));
grid; title('First and Second Covariance Elements');
legend('First Element','Second Element');

figure(7)

```

```
plot(ug); title('Acoustic Doppler Forward Speed (ug)');  
grid;
```

```
figure(8)  
plot(vg); title('Acoustic Doppler Lateral Speed (vg)');  
grid
```

```
figure(9)  
plot(RDI_Alt);hold  
plot(NSv,'m. ');grid;title('Satellite Recognition Response');  
xlabel('Time');ylabel('Number of Satellites and Altitude (meters)');
```

```
figure(10)  
plot(RDI_Alt);hold;plot(ug+7,'r');grid;title('Diving Speed');  
xlabel('Time');ylabel('Depth (meters) and Speed+7 (meters/sec)');
```

1st Accompanying Navigational Filter File:

```
function [xnew]= Prop8_new(xold,tau,tau1,t1,t2)  
X=xold(1);Y=xold(2);psi=xold(3);  
r=xold(4);ug=xold(5);vg=xold(6);  
br=xold(7);bpsi=xold(8);  
f1=ug*cos(psi)-vg*sin(psi);  
f2=ug*sin(psi)+vg*cos(psi);  
f3=r;  
f4=0; f5=0; f6=0;  
f=[f1;f2;f3;f4;f5;f6;0;0];  
xnew=xold+f.*(t1-t2);%xd=f;
```

2nd Accompanying Navigational Filter File:

```
function [yhat]=output8_new(xold)  
  
X=xold(1);Y=xold(2);psi=xold(3);  
r=xold(4);ug=xold(5);vg=xold(6);  
br=xold(7);bpsi=xold(8);  
y1=ug;y2=vg;y3=psi+bpsi;y4=r+br;y5=X;y6=Y;  
yhat=[y1;y2;y3;y4;y5;y6];
```

THIS PAGE INTENTIONALLY LEFT BLANK

LIST OF REFERENCES

1. Hutchinson, B. L., Skov, B. E., "A System's Approach to Navigating and Piloting Small UUV's," Proceedings of the Symposium on Autonomous Underwater Vehicle Technology – AUV 90, Washington, DC, June 1990.
2. Opderbecke, J., Durieu, C., "Vehicle Localization in a Poorly Known Environment," IEEE, 1994.
3. Healey, A. J., An, E. A., Marco, D. B., " On Line Compensation of Heading Sensor Bias for Low Cost AUV's," Proceedings of the IEEE Workshop on Autonomous Underwater Vehicles, AUV98, IEEE Catalog. Number 98CH36290, ISBN # 0-7803-5190-8, August 20-21, 1998, Cambridge, Mass. pp 35-42.
4. Thorne, R., "Asynchronous Data Fusion for AUV Navigation Using Extended Kalman Filtering," M.S. Thesis, Naval Postgraduate School, Monterey, CA 93943, March, 1997.
5. Piton, Gwladys, "Design and Evaluation of a Differential Global Positioning System (DGPS) for the NPS Autonomous Underwater Vehicle", Research Report NPS-ME-99-003, Naval Postgraduate School, Monterey, CA. 93943.
6. Healey, A., Professor, Naval Postgraduate School, Monterey, CA 93943, Private Communication with Author, May, 2000.
7. United States Coast Guard (USCG), www.navcen.uscg.mil/dgps
8. Peter H. Dana, "The Global Positioning System," www.utexas.edu/depts/grg/gcraft/notes/gps/gps_stoc.html, May, 2000.
9. Communications System International (CSI), "ABX-3/MBX-3 Reference Manual," revision 1.0, August 1998.
10. West Virginia Division of Environmental Protection (WVDEP), "Effect of PDOP on Quality of GPS Data," www.dep.state.wv.us/gps/pdop.html, May, 2000.
11. Marco, D., Ph.D, Naval Postgraduate School, Monterey, CA 93940, Private Communication with Author, May, 2000.
12. Ashtech, "G-12 Sensor," www.ashtech.com, May, 2000.
13. Micro Pulse International, "Vehicle Tracking Antennas," www.micropulse.com, May, 2000.
14. RD Instruments, "Workhorse Navigator," www.rdinstruments.com, May, 2000.

15. Systron Donner, "Multi-Axis Inertial Sensing System," www.systron.com, May, 2000.
16. PSI Tronix, "PWC Pressure Transducer/Transmitter," www.psi-tronix.com, May, 2000.
17. Symantec, "Procomm Plus: The Leader in Terminal Emulation," www.symantec.com/procomm/index.html, May, 2000.
18. Maybeck, P. S., "The Kalman Filter: An Introduction to Concepts," Symposium on Autonomous Underwater Vehicle Technology, California, June, 1996.
19. Gelb, A., "Applied Optimal Estimation," Cambridge, Massachusetts, September, 1974.

INITIAL DISTRIBUTION LIST

1. Defense Technical Information Center2
 8725 John J. Kingman Rd., STE 0944
 FT. Belvoir, VA, 22060-6218

2. Dudley Knox Library2
 Naval Postgraduate School
 411 Dyer Rd.
 Monterey, CA, 93943-5101

3. Dr. Anthony J. Healey, Code ME/Hy1
 Mechanical Engineering Department
 Naval Postgraduate School
 Monterey, CA, 93943-5101

4. Mechanical Engineering Department, Code ME1
 Naval Postgraduate School
 Monterey, CA, 93943-5101

5. Engineering and Technology Curricular Officer, Code 341
 Naval Postgraduate School
 Monterey, CA, 93943-5000

6. Dr. Tom Curtin1
 Office of Naval Research
 800 N. Quincy St.
 Arlington, VA, 22217-5660

7. Dr. Edgar An1
 Florida Atlantic University
 Sea Tech Campus
 Institute of Ocean and Systems Engineering
 101 North Dania Beach Rd.
 Dania Beach, FL, 33004

8. Dr. Chris Von Alt1
 Woods Hole Oceanographic Institution
 Deep Submergence Laboratory
 Woods Hole, MA, 02354

9. Dr. Antonio Pascoal1
 Institute Superior Tecnico
 Av. Rovisco Pais,
 1096 Lisboa Codex, PORTUGAL

10. Dr. Marshall L. Nuckols,1
 Department of Naval Architecture, Ocean and Marine Engineering
 US Naval Academy, Mail Stop 11d
 590 Holloway Road
 Annapolis, MD 21402-5042
11. ENS Benjamin M. Stinespring,1
 2639 Washington Blvd.
 Huntington, WV, 25705
12. ENS Keith Kulow,1
 15 Leonardo Dr.
 Clifton Park, NY, 12065
13. ENS Joy Tucker,1
 1047 Stowe Rd.
 Ashtabula, OH, 44004