

NAVAL POSTGRADUATE SCHOOL MONTEREY, CALIFORNIA



THESIS

**THE USE OF NEURAL NETWORKS AS A METHOD
OF CORRELATING THERMAL FLUID DATA TO
PROVIDE USEFUL INFORMATION ON THERMAL
SYSTEMS**

by

Thomas J. Cronley

June 2000

Thesis Advisor:

M. D. Kelleher

Approved for public release; distribution is unlimited.

DTIC QUALITY INSPECTED 4

20000807 075

REPORT DOCUMENTATION PAGE

Form Approved OMB No. 0704-0188

Public reporting burden for this collection of information is estimated to average 1 hour per response, including the time for reviewing instruction, searching existing data sources, gathering and maintaining the data needed, and completing and reviewing the collection of information. Send comments regarding this burden estimate or any other aspect of this collection of information, including suggestions for reducing this burden, to Washington Headquarters Services, Directorate for Information Operations and Reports, 1215 Jefferson Davis Highway, Suite 1204, Arlington, VA 22202-4302, and to the Office of Management and Budget, Paperwork Reduction Project (0704-0188) Washington DC 20503.

| | | | | |
|--|---|--|--|--|
| 1. AGENCY USE ONLY (Leave blank) | | 2. REPORT DATE June 2000 | 3. REPORT TYPE AND DATES COVERED Master's Thesis | |
| 4. TITLE AND SUBTITLE: The Use of Neural Networks as a Method of Correlating Thermal Fluid Data to Provide Useful Information on Thermal Systems | | | 5. FUNDING NUMBERS | |
| 6. AUTHOR(S) Cronley, Thomas J. | | | | |
| 7. PERFORMING ORGANIZATION NAME(S) AND ADDRESS(ES) Naval Postgraduate School Monterey CA 93943-5000 | | | 8. PERFORMING ORGANIZATION REPORT NUMBER | |
| 9. SPONSORING/MONITORING AGENCY NAME(S) AND ADDRESS(ES) | | | 10. SPONSORING/MONITORING AGENCY REPORT NUMBER | |
| 11. SUPPLEMENTARY NOTES The views expressed here are those of the authors and do not reflect the official policy or position of the Department of Defense or the U.S. Government. | | | | |
| 12a. DISTRIBUTION/AVAILABILITY STATEMENT Approved for public release; distribution is unlimited. | | | 12b. DISTRIBUTION CODE | |
| 13. ABSTRACT (maximum 200 words) A study on the use of neural networks as a method of correlating thermal fluid data to provide useful information on thermal systems was conducted using a neural network code package. Two separate thermal fluid systems were analyzed: tube bank data with variable geometries and tube bank boiling data with variable parameters. Both studies show the effectiveness of neural networks as a viable alternative to the current practice of correlating data. This is achieved by displaying a reduction in error, requiring fewer assumptions, and providing an easier method of devising predictions and correlations. | | | | |
| 14. SUBJECT TERMS Neural Networks, Data Correlation, Thermal Systems | | | 15. NUMBER OF PAGES 61 | |
| | | | 16. PRICE CODE | |
| 17. SECURITY CLASSIFICATION OF REPORT Unclassified | 18. SECURITY CLASSIFICATION OF THIS PAGE Unclassified | 19. SECURITY CLASSIFICATION OF ABSTRACT Unclassified | 20. LIMITATION OF ABSTRACT UL | |

NSN 7540-01-280-5500

Standard Form 298 (Rev. 2-89)
Prescribed by ANSI Std. Z39-18 298-102

Approved for public release; distribution is unlimited

**THE USE OF NEURAL NETWORKS AS A METHOD OF CORRELATING
THERMAL FLUID DATA TO PROVIDE USEFUL INFORMATION ON
THERMAL SYSTEMS**

Thomas J. Cronley
Ensign, United States Navy
B.S., University of Notre Dame, 1999

Submitted in partial fulfillment of the
requirements for the degree of

MASTER OF SCIENCE IN MECHANICAL ENGINEERING

from the

**NAVAL POSTGRADUATE SCHOOL
June 2000**

Author: _____

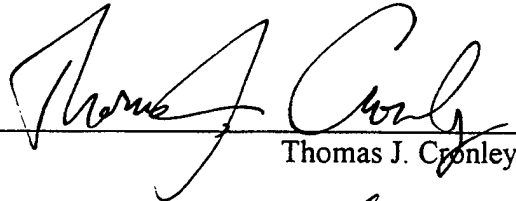
Thomas J. Cronley

Approved by: _____

Matthew D. Kelleher, Thesis Advisor

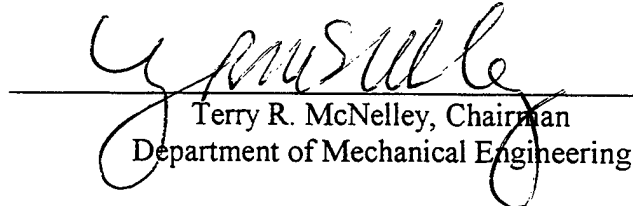
Terry R. McNelley, Chairman
Department of Mechanical Engineering

ABSTRACT

A study on the use of neural networks as a method of correlating thermal fluid data to provide useful information on thermal systems was conducted using a neural network code package. Two separate thermal fluid systems were analyzed: tube bank data with variable geometries and tube bank boiling data with variable parameters. Both studies show the effectiveness of neural networks as a viable alternative to the current practice of correlating data. This is achieved by displaying a reduction in error, requiring fewer assumptions, and providing an easier method of devising predictions and correlations.

TABLE OF CONTENTS

| | | |
|------|--|----|
| I. | INTRODUCTION..... | 1 |
| | A. BACKGROUND..... | 1 |
| | B. THE ARTIFICIAL NEURAL NETWORK..... | 2 |
| | C. PREVIOUS WORK..... | 3 |
| | D. OBJECTIVE..... | 4 |
| II. | THE NEURAL NETWORK..... | 5 |
| | A. GENERAL NEURAL NETWORKS..... | 5 |
| | 1. General Layout..... | 6 |
| | 2. Neuron..... | 7 |
| | 3. Transfer Functions..... | 8 |
| | 4. Training..... | 12 |
| | B. THE SPECIFIC NEURAL NETWORK..... | 13 |
| | 1. Preprocessing..... | 13 |
| | 2. Initialization..... | 13 |
| | 3. Simulation..... | 13 |
| | 4. Training..... | 14 |
| III. | CORRELATING THE GRIMISON DATA..... | 17 |
| | A. DESCRIPTION OF EXPERIMENT..... | 17 |
| | B. PRESENTATION AND USE OF DATA..... | 20 |
| | 1. Reynolds Number..... | 22 |
| | 2. Longitudinal Spacing (S_L)..... | 25 |
| | 3. Transverse Spacing (S_T)..... | 25 |
| IV. | CORRELATING THE MARTO AND ANDERSON DATA..... | 29 |
| | A. DESCRIPTION OF EXPERIMENT..... | 29 |
| | B. PRESENTATION AND USE OF THE DATA..... | 31 |
| | 1. Temperature Above Saturation..... | 35 |
| | 2. Percent Oil Content..... | 38 |
| | 3. Number of Active Tubes..... | 39 |
| V. | CONCLUSIONS & RECOMMENDATIONS..... | 41 |
| | A. CONCLUSIONS..... | 41 |
| | B. RECOMMENDATIONS..... | 41 |
| | LIST OF REFERENCES..... | 43 |

INITIAL DISTRIBUTION LIST 45

LIST OF FIGURES

| | |
|---|----|
| Schematic of a General Backpropagation Network..... | 6 |
| Schematic of Neuron without Bias. | 7 |
| Schematic of Neuron with Bias. | 8 |
| Linear Transfer Function. | 9 |
| Log-Sigmoid Transfer Function. | 9 |
| A Detailed Schematic of One Layer of a Network. | 10 |
| Layout of Input, Hidden and Output Layers [Ref. 7]..... | 11 |
| Schematic of Aligned Configuration. | 18 |
| Schematic of Staggered Configuration. | 20 |
| Example of How Pierson Presented Data in Graphical Form [Ref. 5]. | 21 |
| Plot of Neural Network Output (ANN) vs. the Values Attained by the Grimison Correlation. | 23 |
| Plot of Neural Network Output (ANN) vs. the Values Attained by the Grimison Correlation. This is a Portion of the Previous Figure Shown in More Detail. | 24 |
| Plot of Neural Network Output (ANN) vs. the Values Attained by the Grimison Correlation. | 26 |
| Plot of Neural Network Output (ANN) vs. the Values Attained by the Grimison Correlation. | 27 |
| Sectional View of the Evaporator Used in the Marto and Anderson Experiments. Note the Tube Bundle, the Dummy Tubes, and the Heaters [Ref. 1]. | 30 |
| Heat Flux vs. Temperature Above Saturation for Different Percentage Oil in the Refrigerant [Ref. 1]. | 32 |
| Heat Flux vs. Temperature Above Saturation for Different Numbers of Active Tubes in the Bundle [Ref. 1]. | 33 |
| Heat Flux vs. Temperature Above Saturation for Different Configurations [Ref. 1]. | 34 |
| Plot of the Output of the ANN vs. the Experimentation for Different Temperatures Above Saturation. | 36 |

| | |
|--|----|
| Plot of the Output of the ANN vs. the Experimentation Shown in Detail | 37 |
| Plot of the Output of the ANN vs. the Experimentation for Different Oil % Values. | 39 |
| Plot of the Output of the ANN vs. the Experimentation for Different Numbers of Active Tubes | 40 |

LIST OF TABLES

| | |
|--|----|
| Table of Values to be Used with the Grimison Correlation [Ref. 8]. | 19 |
| Average % Error (Over All Re) for Every Configuration of the Aligned Configuration. | 24 |
| Average % Error (Over All Re) for Every Configuration of the Staggered Configuration. | 25 |
| Average % Error (Over All T) for Every Arrangement of the Smooth Configuration..... | 35 |
| Average % Error (Over All T) for Every Arrangement of the Finned Configuration. | 35 |

ACKNOWLEDGEMENT

I would like to acknowledge the help of Dr. Matthew Kelleher for his direction and assistance as this report was developed. Also I would like to thank Dr. Mihir Sen for his insight and thoughts and for the input from Dr. K. T. Yang.

I. INTRODUCTION

A. BACKGROUND

The complex nature of many common heat transfer situations causes most of the work in thermal fluids to deal with some portion of experimentation. In more complex (and typically, more realistic) systems, analytical solutions are not possible. Whether it is conducting the actual experiments, reviewing the results, using the results, or correlating the results, it is not uncommon for undergraduate students all the way up to corporate engineers to be dealing with experimentation of thermal fluid systems.

With more and more complexity in fluid systems and experimentation, correlation is becoming more and more difficult. Most experiments involve varying fluid properties, variable heat transfer conditions and a host of geometric configurations. With all of these parameters, concise methods of graphical display are impossible and correlations are becoming far too complex for use without a computer program. Because of the assumptions made by these correlations (such as constant fluid properties), inaccuracies and error occur. Even the simplest, most limiting case, correlation development is quite an undertaking and often leads to equations that must be evaluated using computer programs.

In complex situations, the use of traditional, exponential forms to correlate the experimental data results in predictive expressions with inherently large uncertainties. Using the neural network technique, this raw data becomes easier to use as a predictive and design tool.

Neural networks provide an alternative to both graphically represented data and the use of complex correlation equations. The neural network technique provides distinct advantages over other approaches as well as the highest degree of accuracy of the three methods discussed (graphical displays, mathematical correlations, and neural networks). Although the neural network displays usefulness in control, design, and prediction, only the area of prediction of heat transfer parameters will be discussed.

B. THE ARTIFICIAL NEURAL NETWORK

Though it is not the focus of this study to provide a detailed discussion of neural networks, the network that is used will be described so that its use will be understood and enough references will be given if more detail is desired.

The neural network (and loosely artificial intelligence) has been defined in many ways. For this study, the definition provided by Sage is most appropriate, "the development of paradigms or algorithms that require machines to perform cognitive tasks, at which humans are currently better" [Ref. 4]. It may seem inconsistent to use this definition while stating, as above, that the neural network in this study is being used to replace correlations: replacing the computer (rather than the human) with the neural network. However, the neural network will tackle groups of similar correlations. In essence, the neural network will be replacing the human selection of the correlation and the correlation itself.

While it has flourished in other disciplines, the thermal sciences have been a bit reluctant to accept the neural network technique as a method of prediction [Ref. 3]. This is most likely due to the lack of system analysis necessary in order to develop a solution.

Like the human brain, the neural network has no need for an equation in order to develop a solution. This can be best understood through an example from M. Sen of the University of Notre Dame. Take, for example, your car. When you turn the wheel (an input), you do not know how many degrees your front tires will turn. You do, however, know how your car will react when rounding the turn (the output). From human standpoint, it is unnecessary to know the degree value that your tires turned, but only the end result of rounding the corner. For a heat exchanger, this would translate as only having the hot and cold fluid temperatures at the inlet and outputting the output temperatures--no other information is necessary. This is much different than any analytical approach and thus, the community is reluctant to invoke the neural network technique.

C. PREVIOUS WORK

This study, though not a direct continuation of their work, has been inspired by the work done by Sen and Yang of the University of Notre Dame. They have had success in the simulation and control of heat exchanger performance using neural networks. Other heat transfer applications of the neural network technique have been conducted. More specifically, in 1996, Jamunathan et al. [Ref. 9] worked in the area of liquid crystal thermography. In 1994 and 1995, Lavric et al. [Ref. 10] studied the design of a finned tube heat exchanger. In 1994, Huang and Nelson [Ref. 11] determined the delay time for HVAC plants and in 1990, Ding and Wong [Ref. 12] attempt the control of a simulated hydronic system [Ref. 3]. The use of neural networks in thermal fluid problems is a rather "young" subject as shown by the aforementioned exhaustive list of known studies. However, the Artificial Neural Network technique (ANN) is a well-established technique

[Ref. 4]. This study breaks away from other neural network/thermal fluid studies by displaying its usefulness strictly in any area involving the correlation of data.

D. OBJECTIVE

The objective of this study is to investigate the feasibility of employing the neural network technique as a method of using experimental data to predict heat transfer behavior. Currently, data is acquired by experimentation, collected en masse, and then correlated to one or more of the controllable inputs using some fluid mechanics insight and some mathematical know-how. Experimental uncertainties in the data accumulation are coupled with the inherent uncertainties in the mathematical correlation. The correlation, in order to be useful, is typically called upon to accommodate a range of inputs that leads to more error. Incropera and DeWitt [Ref. 2] comment that the correlations should not be viewed as sacrosanct, "Each correlation is reasonable over a certain range of conditions, but for most engineering calculations one should not expect accuracy too much better than 20%."

It is the goal, then, to make the predictions of thermal fluid behavior more reliable (i.e. less error), less reliant on assumptions, and provide easier methods of evaluating these predictions. With neural networks all of the above goals are realized. However, as an additional goal, this report attempts to familiarize the thermal fluid community with the unique capabilities of ANN as a predictive technique.

II. THE NEURAL NETWORK

A. GENERAL NEURAL NETWORKS

As mentioned previously, this report does not intend to be a survey in neural networks. However, it will offer a brief explanation and will make reference to many other sources of such information. For a mathematical and historical background of neural networks reference the text by Haykin [Ref. 4]. The paper by Sen and Yang [Ref. 3] provides an extensive review of the applications of artificial neural networks and genetic algorithms in thermal engineering.

Although many different types of neural networks exist, this study and most engineering applications primarily invoke the use of the supervised fully connected single and multi-layer feedforward network with backpropagation. As its name implies, neural networks are based on the biological make-up that runs the brain, whether it is human or non-human. Like the brain, the neural network learns, recognizes information, and makes generalizations on the input it receives [Ref. 3]. The essence of the method is to "train the network" with inputs that correspond to known outputs. Through a process that is roughly labeled "experience," the neural network is able develop the understanding of what output results from certain inputs.

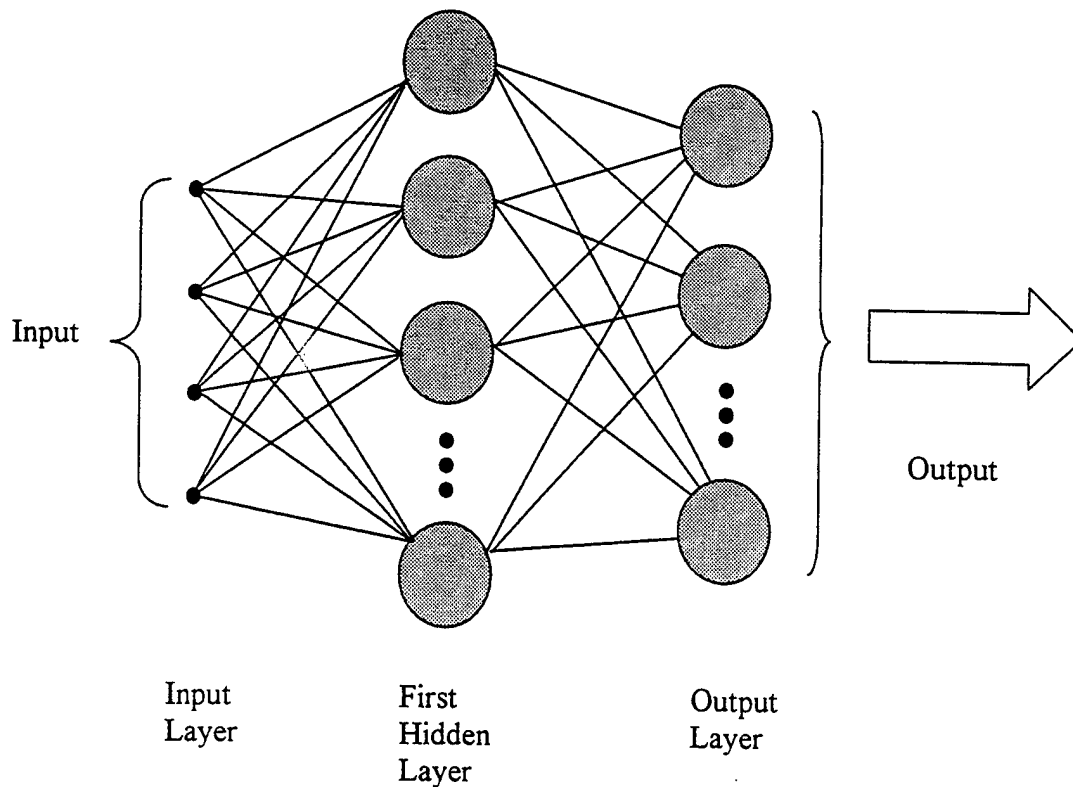

Figure 1: Schematic of a General Backpropogation Network.

1. General Layout

Figure 1 presents the layout of a single hidden layer fully connected feedforward network. This layout represents only one type of network, albeit the most important network for this study. Each gray circle represents a neuron of the network and implements a function to determine the output of that neuron. The input layer shows that this network has four inputs, one hidden layer (this layer is neither an input or output layer), and an output layer with a set of neurons. The hidden layer and output layer invoke a function that determines each layer's output.

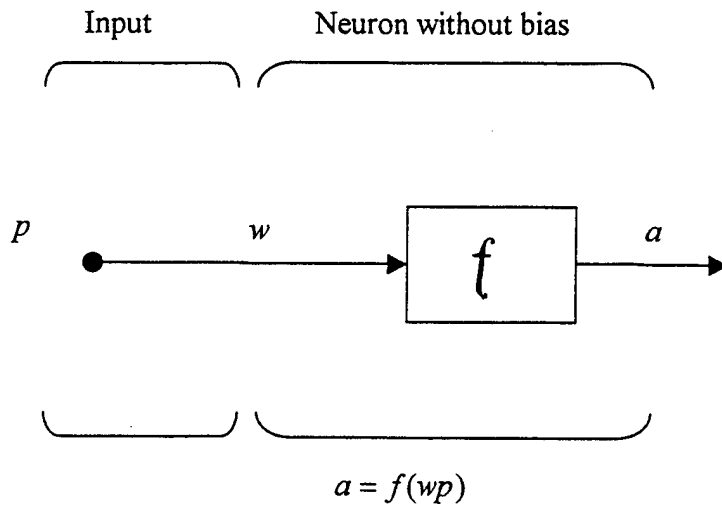

Figure 2: Schematic of Neuron without Bias.

2. Neuron

A neuron with a single scalar input and no bias is shown in Fig. 2 and with bias in Fig. 3. The scalar input p is multiplied by the weight function w and remains a scalar value wp . For the neuron without bias, the wp is the only argument for the transfer function. For the neuron with bias, the argument for the transfer function is altered by b . The transfer function f , typically a sigmoid or a linear transfer function (discussed in the following section), is set before the network is trained. It takes the argument wp (or $wp+b$) and produces the output, a . Note that w and b are both adjustable. These are the quantities that are adjusted so that the network can produce output that is consistent with the training [Ref. 7].

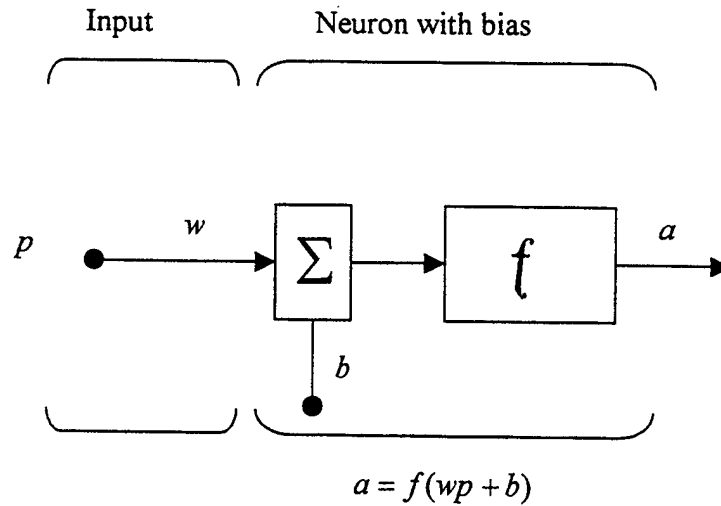

Figure 3: Schematic of Neuron with Bias.

3. Transfer Functions

Each neuron has an input/output characteristic and implements a transfer function. The two transfer functions used in this study are the linear transfer function (shown in Fig. 4) and the log-sigmoid transfer function (shown in Fig. 5). The linear transfer function calculates the neuron's output by returning the value passed to it. The log-sigmoid transfer function takes the input, which is any real value and returns with an output between the range of 0 and 1. The algebraic form is given in Eq. 2.1.

$$f(n) = \frac{1}{1 + e^{-n}} \quad (2.1)$$

Networks with biases, a sigmoid layer, and a linear output layer are capable of approximating any function with a finite number of discontinuities [Ref. 7].

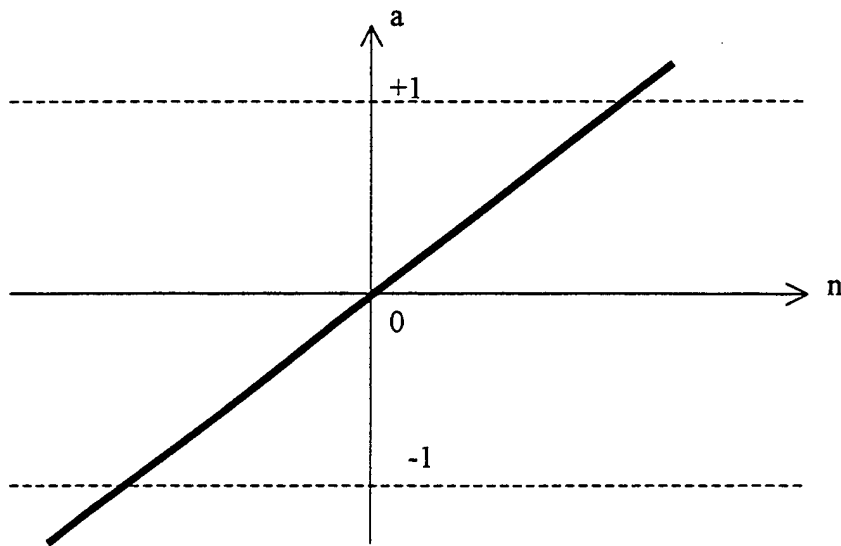

Figure 4: Linear Transfer Function.

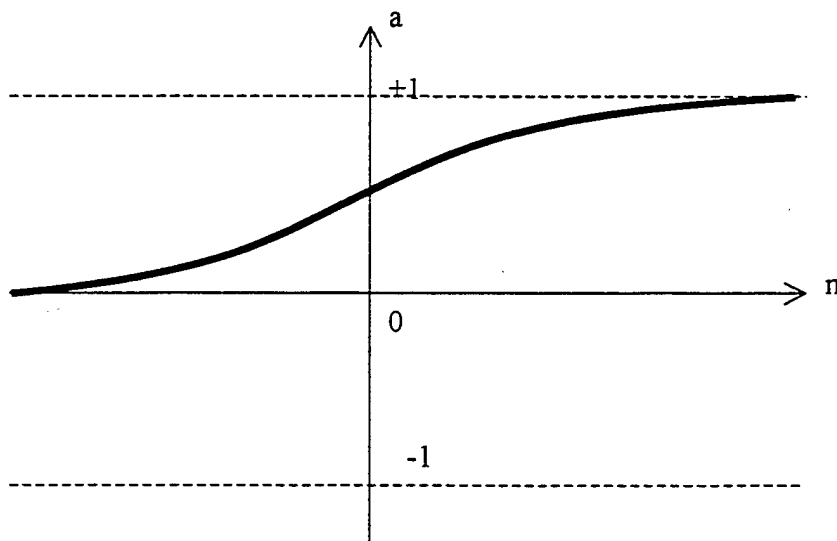

Figure 5: Log-Sigmoid Transfer Function.

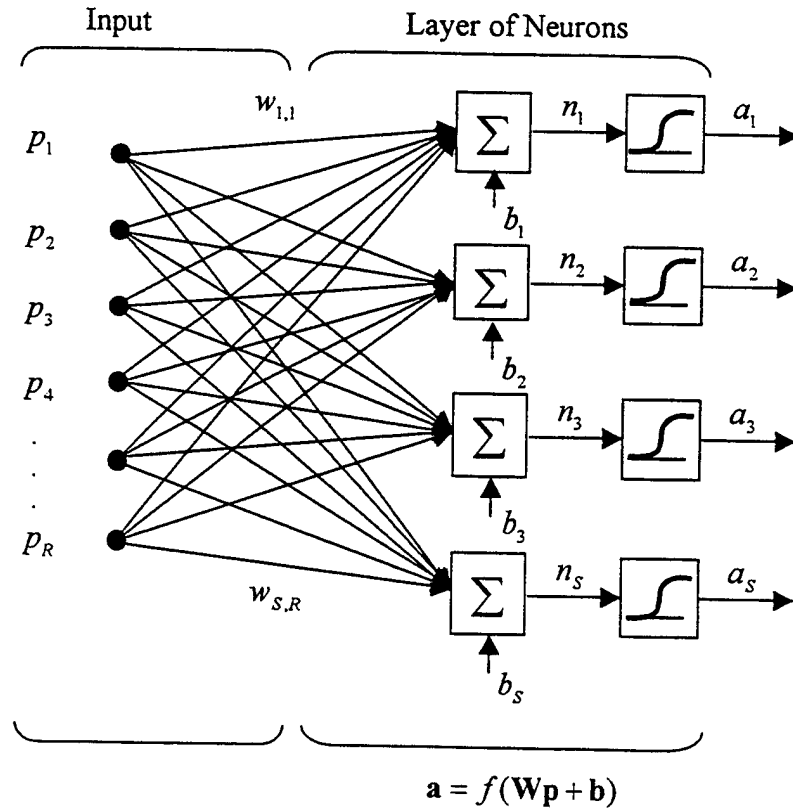

Figure 6: A Detailed Schematic of One Layer of a Network.

Figure 6 shows a single layer network of S log-sigmoid neurons having R inputs. In order to achieve an output outside of the range of 0 and 1, another of layer of linear transfer functions would be necessary. For this type of network the input of the next layer would be the a vector. This type of network is shown in Fig. 7. A vector of input p is the argument of the hidden layer transfer function. The output of this layer, a_1 is the argument for the output layer transfer function. The vector a_2 is the output of the second layer and the network altogether.

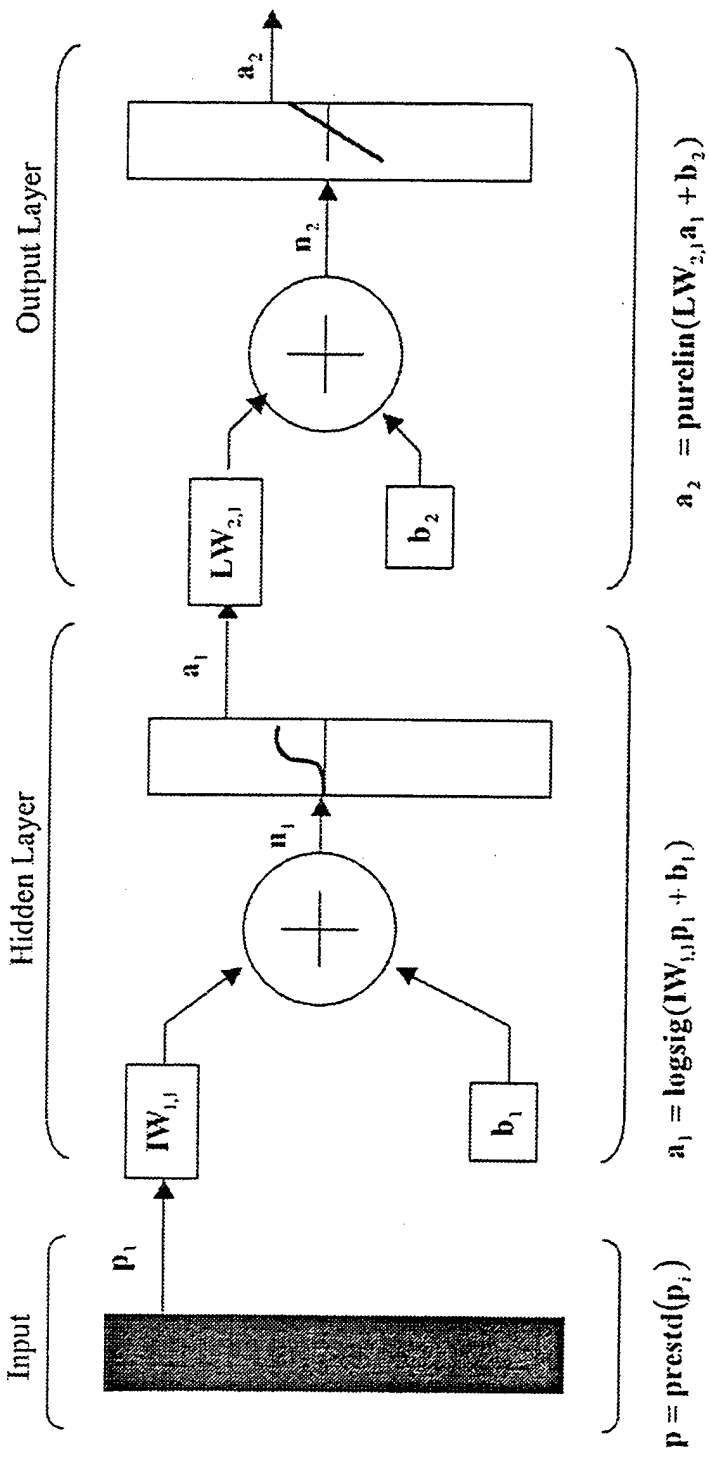

Figure 7: Layout of Input, Hidden and Output Layers [Ref. 7].

Also in Fig. 7, notice the transfer functions are given below the schematic of the network. The hidden layer transfer function is a log-sigmoid and the output layer is the linear transfer function. Each layer has a bias, \mathbf{b}_n and a layer (or input) weight \mathbf{LW} (or \mathbf{IW}) [Ref. 7].

4. Training

The training of the network requires a set of examples of proper network behavior from which the network can make proper pattern associations. The set of examples has both the vector input (or matrix of inputs) and the output corresponding to the input (the targets). During the training, weights and biases of the network are iteratively adjusted to minimize a function set as the measure of network performance. Typically, the gradient of the performance function is used to determine the adjustments of the weights and biases. The gradient is determined using a technique which involves performing computations backwards through the network. This backpropagation invokes optimization techniques (such as Newton methods, secant method or conjugate gradient) to compute the gradients for multi-layered networks. Input vectors and the corresponding output vectors are used to train a network until the approximation of a function is reached. Properly trained backpropagation networks typically approximate functions well even when presented with inputs different from the training data [Ref. 7]. This generalization allows the training of a network to be done with a finite set of data, rather than an exhaustive data bank.

B. THE SPECIFIC NEURAL NETWORK

In this section, the primary network that was used in the study will be discussed. Like the general network described above, this network has the same basic architecture: an input layer, a hidden layer with a set number of neurons, and an output layer. It includes both a log-sigmoid (hidden layer) and a linear transfer function (output layer), and was trained using a set of example data. This type of network is shown in Fig. 7. In order to make the network more efficient the training data was preprocessed.

1. Preprocessing

A neural network's training can be made more efficient if certain preprocessing steps are performed on the network inputs and targets. The training data inputs and targets were preprocessed by normalizing them by their respective mean and standard deviation.

2. Initialization

Once the network architecture is set, the network variables (weights and biases) are initialized. This gives values to the weights and biases so that the first backpropagation iteration, or epoch, can begin. Typically one epoch of training is defined as a single presentation of all input vectors to the network. The network is then updated according to the results of all those presentations.

3. Simulation

With the network initialized, a simulation can be done. This will confirm that the network is setup to receive the input, apply the weights and biases and produce an output.

However, without iterating to find the optimal weights and biases, the output of the network will not approximate the targets with any accuracy.

4. Training

With the assumption that the network was setup with enough neurons in the hidden layer, the training will be able to adjust the weights and bias in order to approximate any function with a finite number of discontinuities. The backpropagation algorithm updates the weights and biases in the direction in which the performance function decreases most rapidly. The iteration can be written [Ref. 7]

$$\mathbf{x}_{k+1} = \mathbf{x}_k - \alpha_k \mathbf{g}_k \quad (2.1)$$

where \mathbf{x}_k is a vector of current weights and biases, \mathbf{g}_k is the current gradient, and α_k is the learning rate. The training is then done in batch mode where all of the inputs are applied to the network before the weights are updated. The gradients calculated at each training example are summed to determine the adjustment of the weights and biases.

In order to find the amount to adjust the weights and biases the Levenberg-Marquardt algorithm is used. By employing this technique, a second-order training speed is achieved by approximating the Hessian matrix. The Hessian matrix is vital to backpropagation learning dynamics. According to Haykin [Ref. 4]:

The *Hessian Matrix* of the cost function $\xi_{av}(\mathbf{w})$, denoted by \mathbf{H} is defined as the second derivative of $\xi_{av}(\mathbf{w})$ with respect to the weight vector \mathbf{w} , as shown by

$$\mathbf{H} = \frac{\partial^2 \xi_{av}(\mathbf{w})}{\partial \mathbf{w}^2}$$

The Hessian matrix plays an important role in the study of neural networks; specifically, we may mention the following:

1. The eigenvalues of the Hessian matrix have a profound influence on the dynamics of back-propagation learning.
2. The inverse of the Hessian matrix provides a basis for pruning (i.e. deleting) insignificant synaptic weights from a multi-layer perceptron, as discussed in Section 4.15. [in Haykin]
3. The Hessian matrix is basic to the formulation of second-order optimization methods as an alternative to back-propagation learning, as discussed in Section 4.18. [in Haykin]

The Levenberg-Marquardt algorithm approximates the Hessian matrix in the following iteration [Ref. 7]:

$$\mathbf{x}_{k+1} = \mathbf{x}_k - [\mathbf{J}^T \mathbf{J} + \mu \mathbf{I}]^{-1} \mathbf{J}^T \mathbf{e} \quad (2.2)$$

and

$$\mathbf{H} = \mathbf{J}^T \mathbf{J} \quad (2.3)$$

where \mathbf{e} is the vector of network errors with respect to the weights and biases, \mathbf{H} is the Hessian matrix, \mathbf{J} is the Jacobian matrix of the weights and biases, μ representative value of the performance function.

[THIS PAGE INTENTIONALLY LEFT BLANK]

III. CORRELATING THE GRIMISON DATA

A. DESCRIPTION OF EXPERIMENT

To show the usefulness of neural networks in thermal fluids applications, a set of training data is needed. Although there are no real requirements on what type of data is desired, a few guidelines helped the selection of the data set. For this experiment it was desired that the data set be well-known, easily (and relatively quickly) entered on a computer, and complicated enough to display the neural network's usefulness. For these reasons the Grimson data [Ref. 8] was chosen.

Although the Grimson data are not numerically accurate for each arrangement, the network was trained as if the data were accurate (i.e. the data was used as the training data). Grimson's relations were developed from the original experimental investigations reported by Huge [Ref. 6] and Pierson [Ref. 5]. The data by Huge and Pierson would be ideal for use as the training data. However, in each of their reports, data is recorded graphically which makes accurate use of their data quite difficult. For this reason the Grimson correlation data is used instead.

Grimson has obtained a correlation of the form [Ref. 2]

$$\overline{Nu}_D = C_1 Re_{D,\max}^m \quad \left(\begin{array}{l} N_L \geq 10 \\ 2000 < Re_{D,\max}^m < 40,000 \\ Pr = 0.7 \end{array} \right) \quad (3.1)$$

where C_1 and m are listed in Table 1.

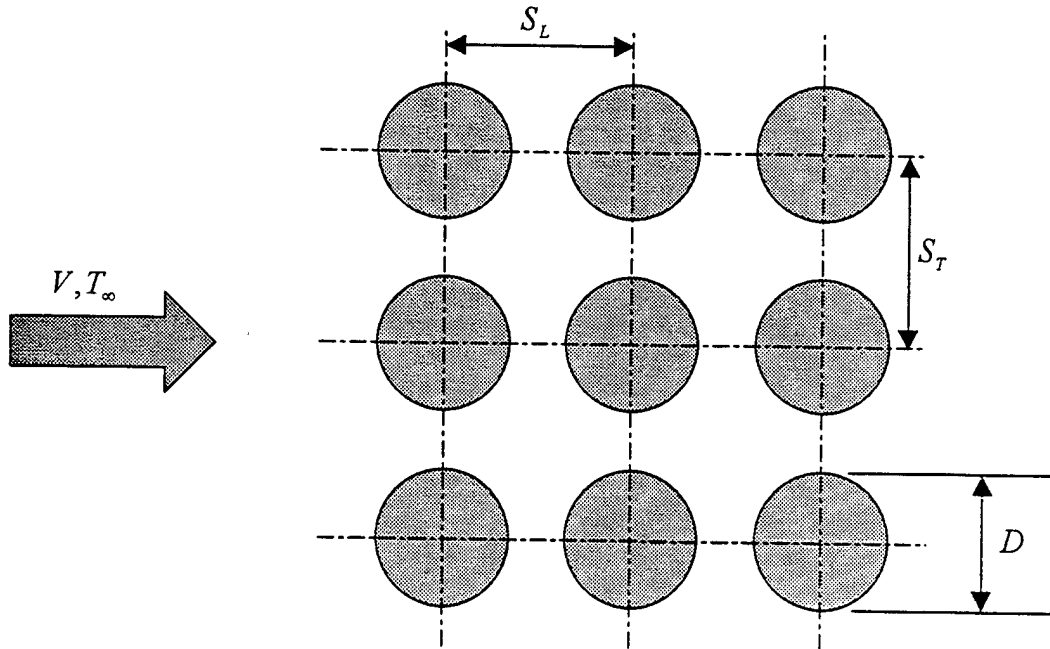

Figure 8: Schematic of Aligned Configuration.

The tube arrangements are shown in Figs. 8 (aligned) and 9 (staggered). The Reynolds number is given by

$$Re_{D,\max} = \frac{\rho V_{\max} D}{\mu} \quad (3.2)$$

where ρ is the fluid density and μ is the dynamic viscosity. V_{\max} for each tube arrangement is given by [Ref. 2]

$$V_{\max} = \frac{S_T}{S_T - D} V \quad (\text{for aligned, see Fig. 8}) \quad (3.3)$$

or for the staggered configuration, the maximum velocity may occur at the transverse plane A_1 or the diagonal plane A_2 (see Fig. 9). It will occur at A_2 if

$$2(S_D - D) < (S_T - D) \quad (3.4)$$

and the value will be given by [Ref. 2]

$$V_{\max} = \frac{S_T}{2(S_D - D)} V \quad (\text{for staggered, see Fig. 9}) \quad (3.5)$$

If V_{\max} occurs at A_1 , it may be computed like the aligned configuration in Eq. 3.3.

Table 1: Table of Values to be Used with the Grimison Correlation [Ref. 8].

| | | $\frac{S_T}{D}$ | | | | | | | |
|-----------|--|-----------------|-------|-------|-------|-------|-------|--------|-------|
| | | 1.25 | | 1.50 | | 2.00 | | 3.00 | |
| S_L/D | | C_1 | m | C_1 | m | C_1 | m | C_1 | m |
| Aligned | | | | | | | | | |
| 1.25 | | 0.348 | 0.592 | 0.275 | 0.608 | 0.100 | 0.704 | 0.0633 | 0.752 |
| 1.50 | | 0.367 | 0.586 | 0.250 | 0.620 | 0.101 | 0.702 | 0.0678 | 0.744 |
| 2.00 | | 0.418 | 0.570 | 0.299 | 0.602 | 0.229 | 0.632 | 0.198 | 0.648 |
| 3.00 | | 0.290 | 0.601 | 0.357 | 0.584 | 0.374 | 0.581 | 0.286 | 0.608 |
| Staggered | | | | | | | | | |
| 1.25 | | 0.518 | 0.556 | 0.505 | 0.554 | 0.519 | 0.556 | 0.522 | 0.562 |
| 1.50 | | 0.451 | 0.568 | 0.460 | 0.562 | 0.452 | 0.568 | 0.488 | 0.568 |
| 2.00 | | 0.404 | 0.572 | 0.416 | 0.568 | 0.482 | 0.556 | 0.449 | 0.570 |
| 3.00 | | 0.310 | 0.592 | 0.356 | 0.580 | 0.440 | 0.562 | 0.428 | 0.574 |

Table 1 and Grimison's associated equation (Eq. 3.1) show that this data set has four inputs: the transverse spacing S_T , the longitudinal spacing S_L , the Reynolds number Re and whether the tube rows of a bank are either *staggered* or *aligned* and one output: the Nusselt number \overline{Nu}_D . Four values different values were used for S_T and S_L (See Table 1). Re was varied between 2,000 and 40,000 at increments of 2,000 for use in Eq. 3.1. Each of these data sets was used for both the *staggered* and the *aligned* configuration for a total of 640 training data sets.

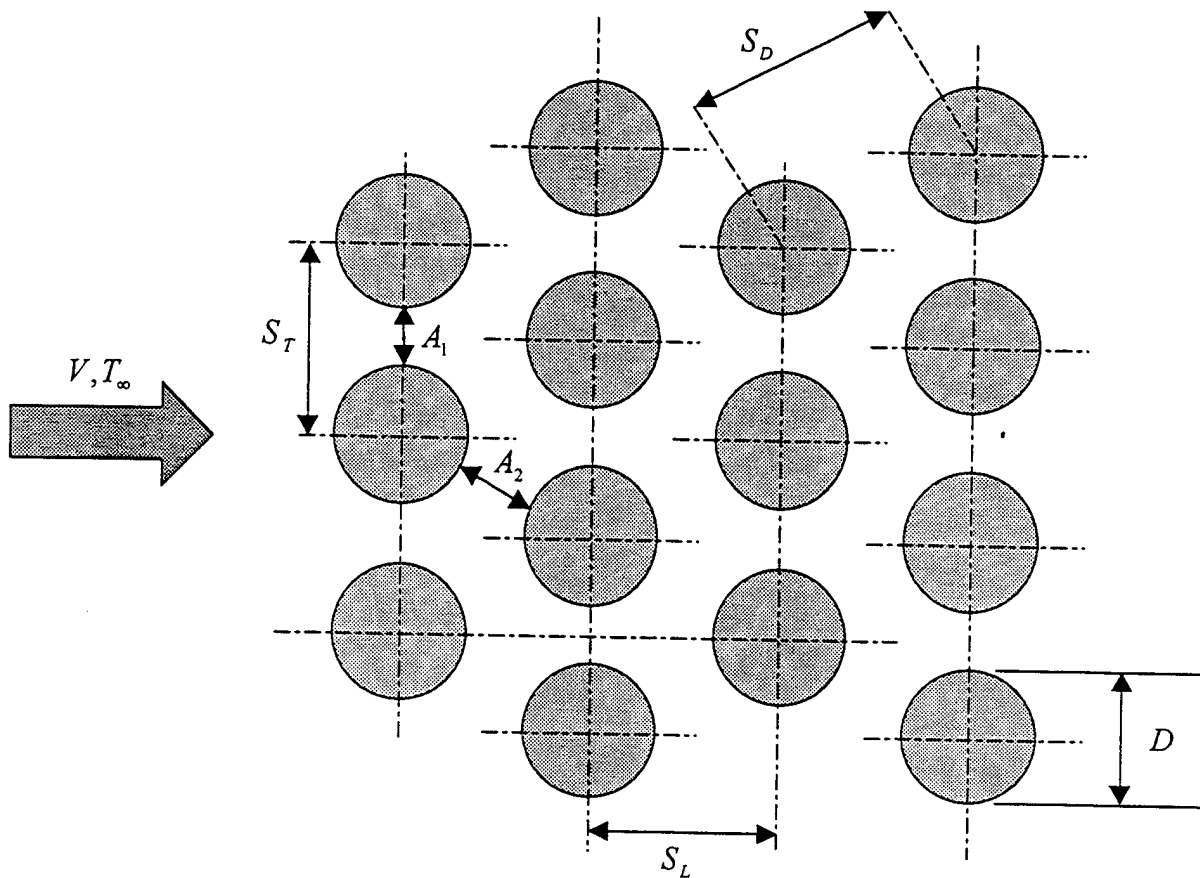

Figure 9: Schematic of Staggered Configuration.

B. PRESENTATION AND USE OF DATA

Using the arrangements shown schematically in Figs. 8 and 9, Pierson and Huge independently developed sets of data of Nusselt number as a function of Reynolds number for different arrangements. As described their reports, much effort was made to maintain accuracy throughout the experimentation. Their data, because quite valuable at the time, was reported exclusively in graphical form (See Fig. 10). Trends are immediately apparent, however. Nusselt numbers were shown to increase "roughly as the two-thirds power of Reynolds number" [Ref. 5]. Yet no correlation was made.

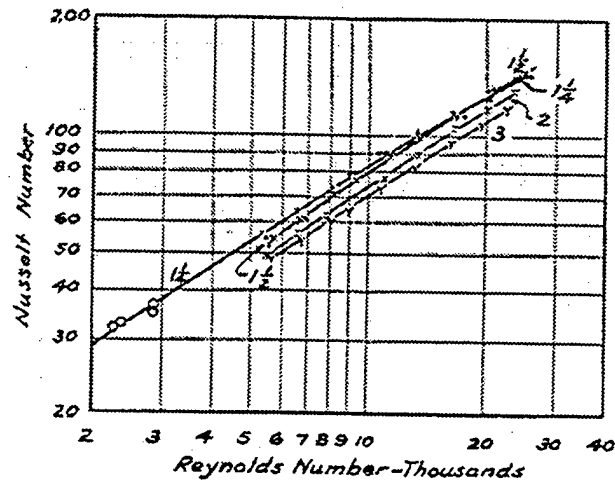

Figure 10: Example of How Pierson Presented Data in Graphical Form [Ref. 5].

Although the data was extremely useful in its own right, not until Grimson made a correlation did the data find usefulness in the investigation of tube banks. With the use of the correlation (and the associated table of C_1 and m values, See Table 1), the Nusselt number could be predicted without experiment or interpolation of Pierson's or Huges data. Grimson, however, admittedly modified the original observed and measured data. Even after these alterations, the bulk of the data was reported to be on the order of $\pm 5\%$ with the staggered banks "somewhat greater" [Ref. 8].

Using the Grimson data as the target (for reasons described above), the neural network is able to provide much more accurate results. The network is trained with one set of data ($Nu = f(Re, S_T, S_L, config)$). In order to test its ability to predict system's behavior, a different set of input is given to the network and the output of the network is compared to the output of the correlation.

1. Reynolds Number

Figures 11 and 12 show that the network could make accurate predictions given Reynolds numbers different from those with which it was trained. Since there are four inputs, the plot displays the output of the neural network versus what the Grimison data would provide. A perfect correlation would produce a 1:1 ratio (a 45° line). In the worst case,

$$\%Error = \frac{NET - DATA}{DATA} = O(10^{-3}) \quad (3.6)$$

In Tables 2 and 3, the *aligned* and *staggered* % error is shown. Each value corresponds to the average over the range of Reynolds number ($2000 \leq Re \leq 40,000$).

The correlation was reached relatively easily and quickly after developing a suitable network to train. The hidden layer consisted of 200 neurons and one neuron in the output layer.

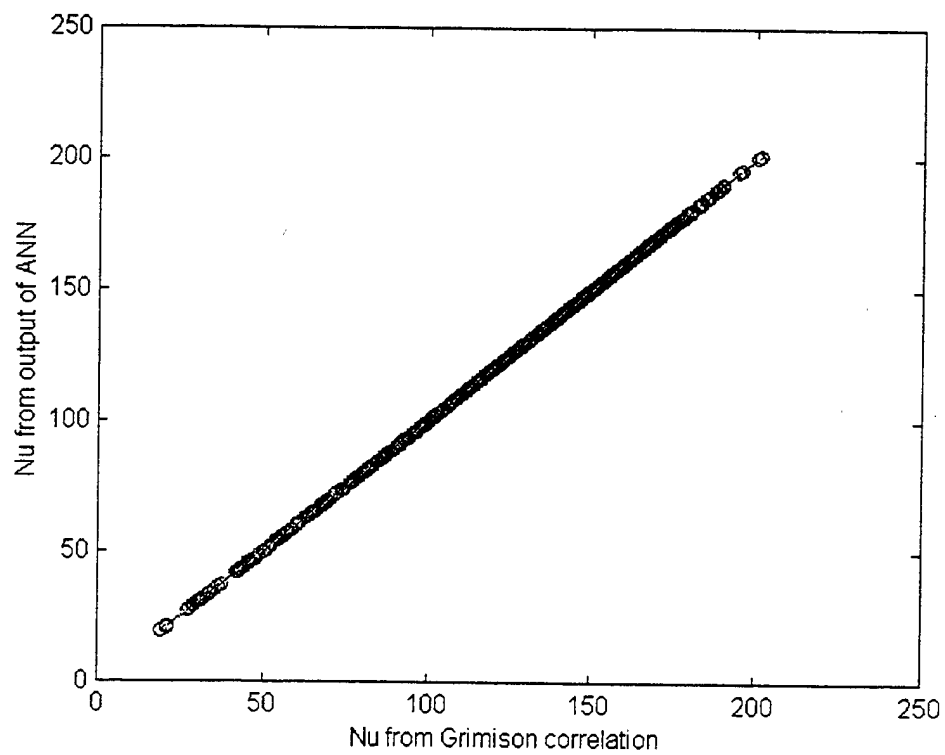

Figure 11: Plot of Neural Network Output (ANN) vs. the Values Attained by the Grimison Correlation.

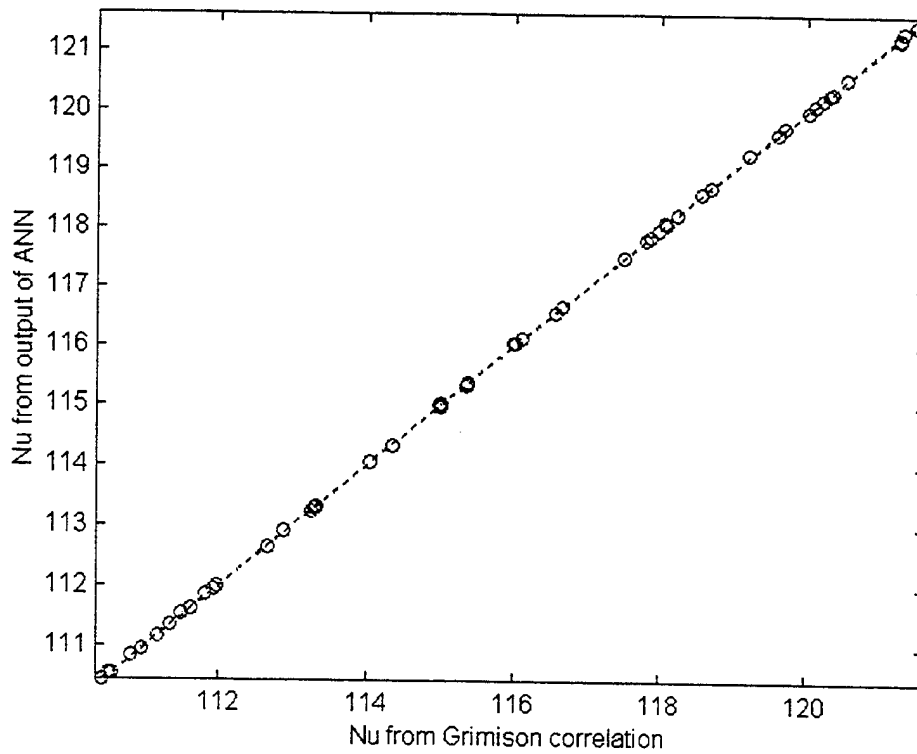

Figure 12: Plot of Neural Network Output (ANN) vs. the Values Attained by the Grimison Correlation. This is a Portion of the Previous Figure Shown in More Detail.

Table 2: Average % Error (Over All Re) for Every Configuration of the Aligned Configuration.

| $S_T \mid S_L \rightarrow$ | 1.25 | 1.50 | 2.00 | 3.00 |
|----------------------------|--------|--------|--------|--------|
| \downarrow | | | | |
| 1.25 | 0.106 | 0.0791 | 0.0969 | 0.0717 |
| 1.50 | 0.107 | 0.0346 | 0.0418 | 0.0738 |
| 2.00 | 0.0826 | 0.0721 | 0.0727 | 0.0776 |
| 3.00 | 0.106 | 0.604 | 0.0630 | 0.179 |

Table 3: Average % Error (Over All Re) for Every Configuration of the Staggered Configuration.

| $S_T \downarrow S_L \rightarrow$ | 0 | 1 | 2 | 3 |
|----------------------------------|--------|--------|--------|--------|
| 1 | 0.0190 | 0.0179 | 0.0223 | 0.0150 |
| 2 | 0.0244 | 0.0160 | 0.0212 | 0.0314 |
| 3 | 0.0426 | 0.0512 | 0.0228 | 0.0196 |
| 4 | 0.0282 | 0.0310 | 0.0106 | 0.0350 |

2. Longitudinal Spacing (S_L)

Figure 13 shows that the network could make accurate predictions given longitudinal spacing (S_L) different from that with which it was trained. Since there are four inputs, the plot displays the output of the neural network versus what the Grimson data would provide. A perfect correlation would produce a 1:1 ratio (a 45° line). Training the network without any input that included $S_L = 2$ attained the output shown in Fig. 13. The data with $S_L = 2$ was then input into the trained network.

3. Transverse Spacing (S_T)

Figure 14 shows that the network could make accurate predictions given transverse spacing (S_T) different from that with which it was trained. Since there are four inputs, the plot displays the output of the neural network versus what the Grimson data would provide. A perfect correlation would produce a 1:1 ratio (a 45° line). Training the network without any input that included $S_T = 2$ attained the output shown in Fig. 14. The data with $S_T = 2$ was then input into the trained network.

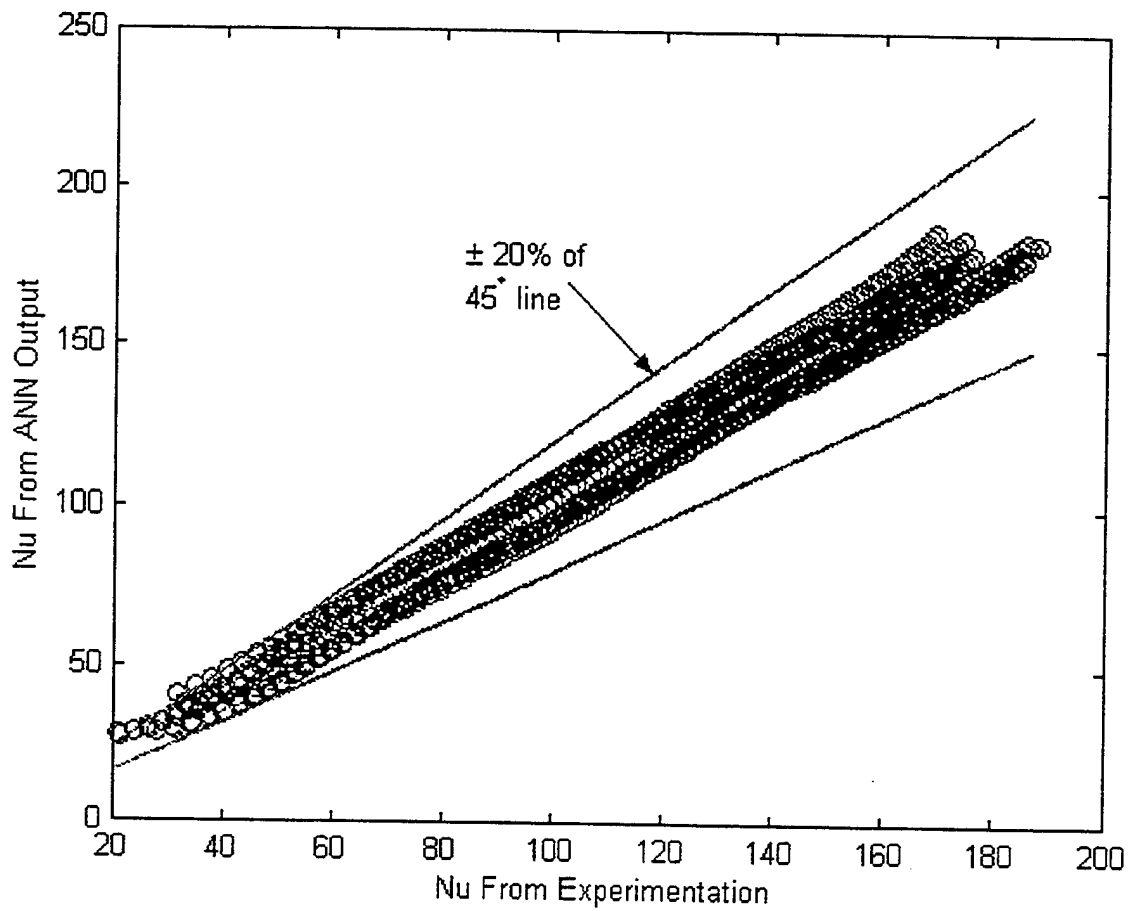

Figure 13: Plot of Neural Network Output (ANN) vs. the Values Attained by the Grimison Correlation.

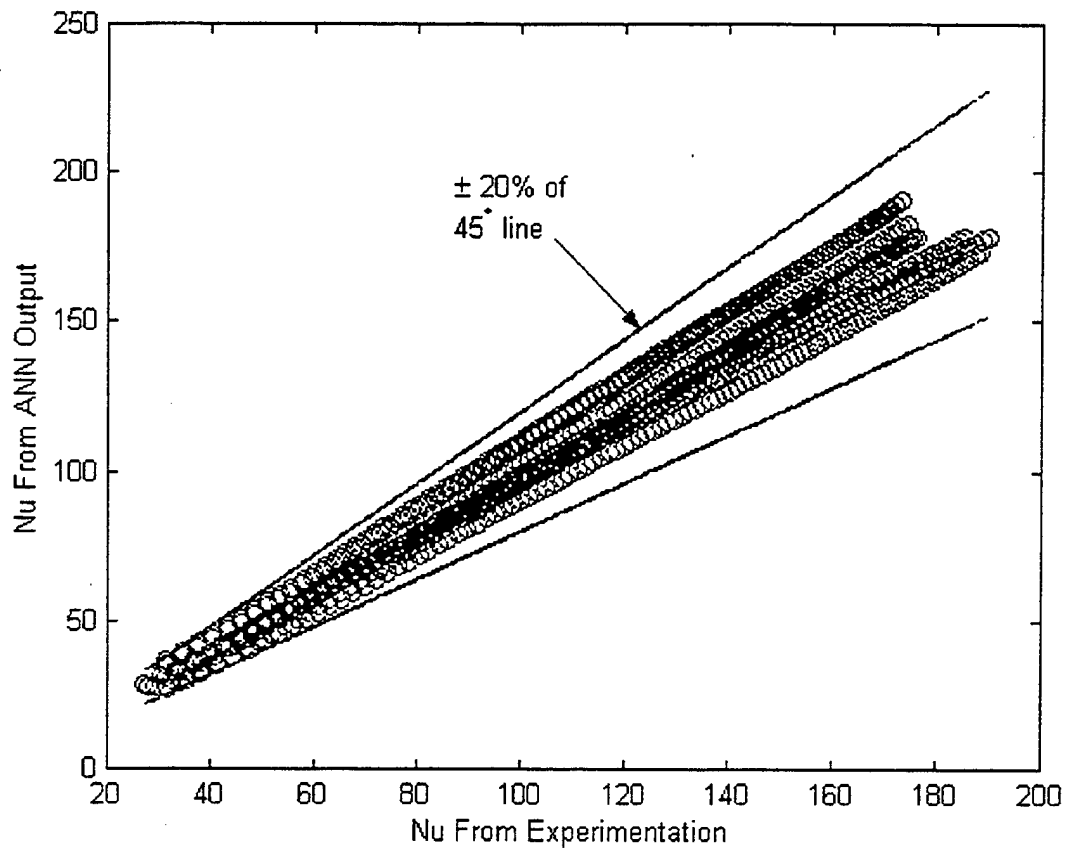

Figure 14: Plot of Neural Network Output (ANN) vs. the Values Attained by the Grimison Correlation.

[THIS PAGE INTENTIONALLY LEFT BLANK]

IV. CORRELATING THE MARTO AND ANDERSON DATA

A. DESCRIPTION OF EXPERIMENT

To display the neural network's usefulness, a set of data that had not yet been correlated was desired. Boiling data from the Masters of Science Thesis of Anderson conducted under the direction of Marto of the Naval Postgraduate School in Monterey, CA was not correlated and thus provided an ideal data source. In the study conducted by Anderson [Ref. 1], nucleate pool-boiling performance of smooth and finned tubes in pure R-114 and R-144/oil mixtures were investigated. The tests were performed with a variable number of active tubes (1-5) and variable amounts of oil in the refrigerant (0-10% by mass). Note that for input "6," the number of active tubes does not correspond to six active tubes, but rather five active tubes and five dummy pairs. With the apparatus (shown in Fig. 15) filled with the R-114/oil mixture, heat was added through the active tubes, the simulation heaters and auxiliary heaters. Once saturation conditions were reached and the transients had subsided, measurements of temperature and heat flux were taken. No correlation of this data was ever developed because of its complexity, although interest in its use remained high.

Figure 15 shows the schematic of the experiment. There are four inputs in this experiment: the temperature above saturation ΔT , the percent oil in the refrigerant, the number of active tubes, and whether the tubes are finned or staggered. The output is the heat flux, q .

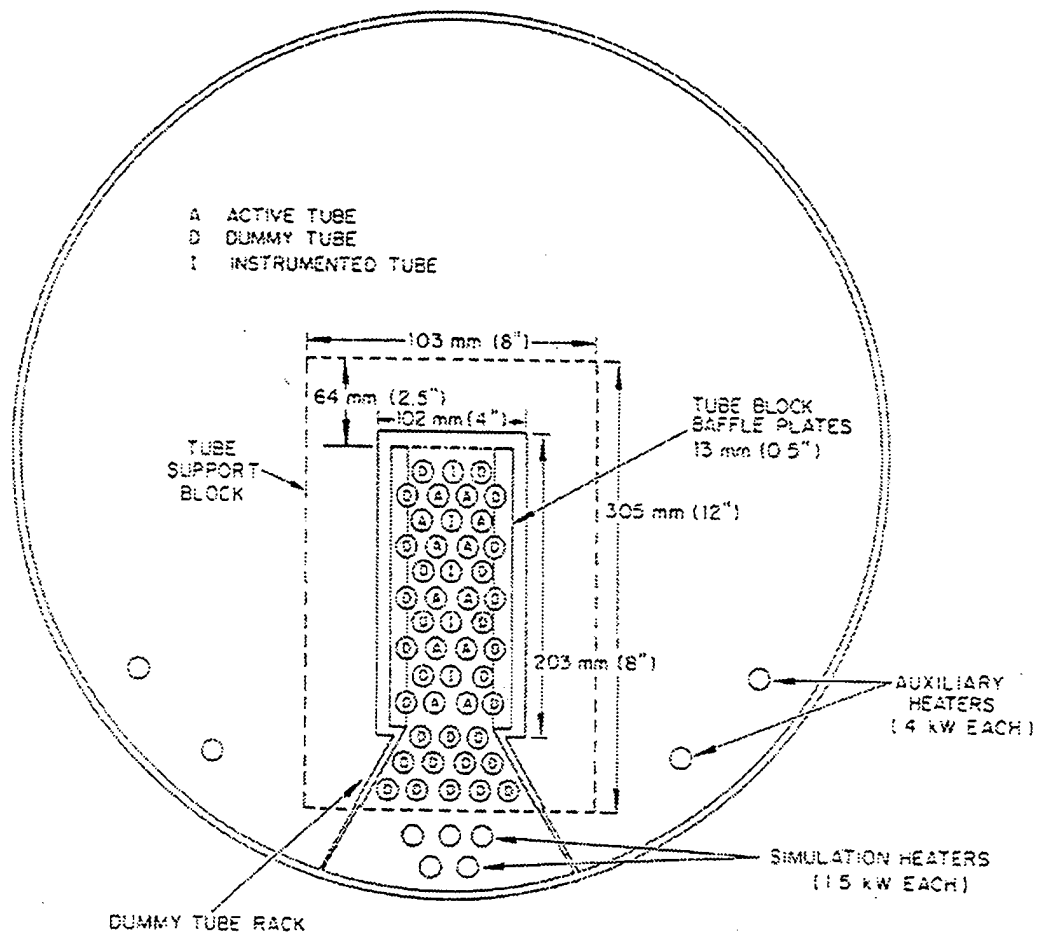

Figure 15: Sectional View of the Evaporator Used in the Marto and Anderson Experiments. Note the Tube Bundle, the Dummy Tubes, and the Heaters [Ref. 1].

From first principles, it is understood that as ΔT increases, q will increase. The same is true for whether the tubes are finned or staggered (keeping the rest constant); q will increase when using finned tubes. The percent oil in the refrigerant is less exact, however. At smaller ΔT , increasing the oil % has the effect of increasing q , while at larger ΔT , it decreases the value of q . Similarly, the increase of active tubes in a bundle has a non-linear effect. Vapor-bubble agitation created by lower tubes in a bundle is expected to enhance the performance of the upper tubes. The presence of too many bubbles may provide insufficient liquid to the surface of the tubes and therefore lower the performance [Ref. 7].

B. PRESENTATION AND USE OF THE DATA

Figures 16-18 show plots of the original output data produced by Anderson. In Fig. 16, heat flux versus temperature above the saturation level is shown for different percent oil by mass. The other parameters (number of active tubes, one tube, and the configuration, smooth) are kept constant. Figure 17 shows heat flux versus temperature above the saturation level for different number of active tubes. The other parameters (percent oil, six percent, and the configuration, smooth) are kept constant. Figure 18 shows heat flux versus temperature above the saturation level for the different configurations. The other parameters (percent oil, zero percent and the number of active tubes, one tube) are kept constant.

If all the combinations of inputs were to be plotted here, another 60 plots would be necessary. However, this is not a practical method for using this data. A correlation is necessary to make this data useful. Using all the data, the network correlates very well.

In Tables 4 and 5, the *smooth* and *finned* % error is shown. Each value corresponds to the average value over the entire group of temperatures over the saturation for each configuration. The error reported by Anderson [Ref. 1] is given by

$$\frac{\Delta q}{q} = 0.008 \quad (4.1)$$

This is quite an aggressive claim for total error. Even so, however, as shown Tables 4 and 5, the error of the neural network are well under the error brought about by most correlations--not to mention that this *one* correlation can be used for 72 different configurations with varying temperature.

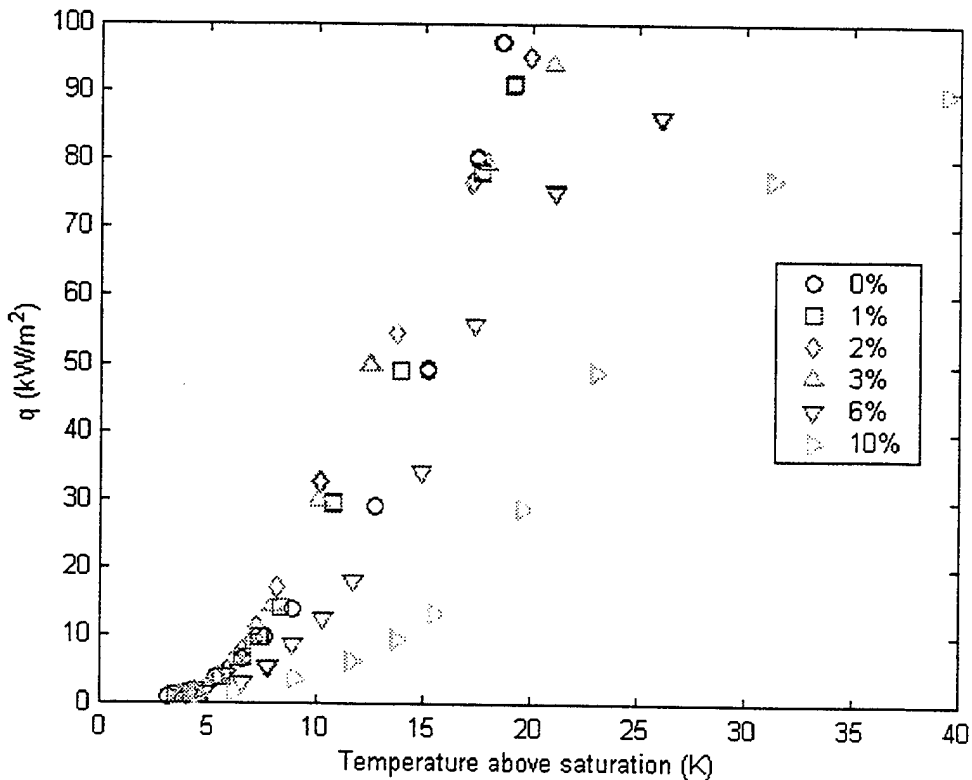

Figure 16: Heat Flux vs. Temperature Above Saturation for Different Percentage Oil in the Refrigerant [Ref. 1].

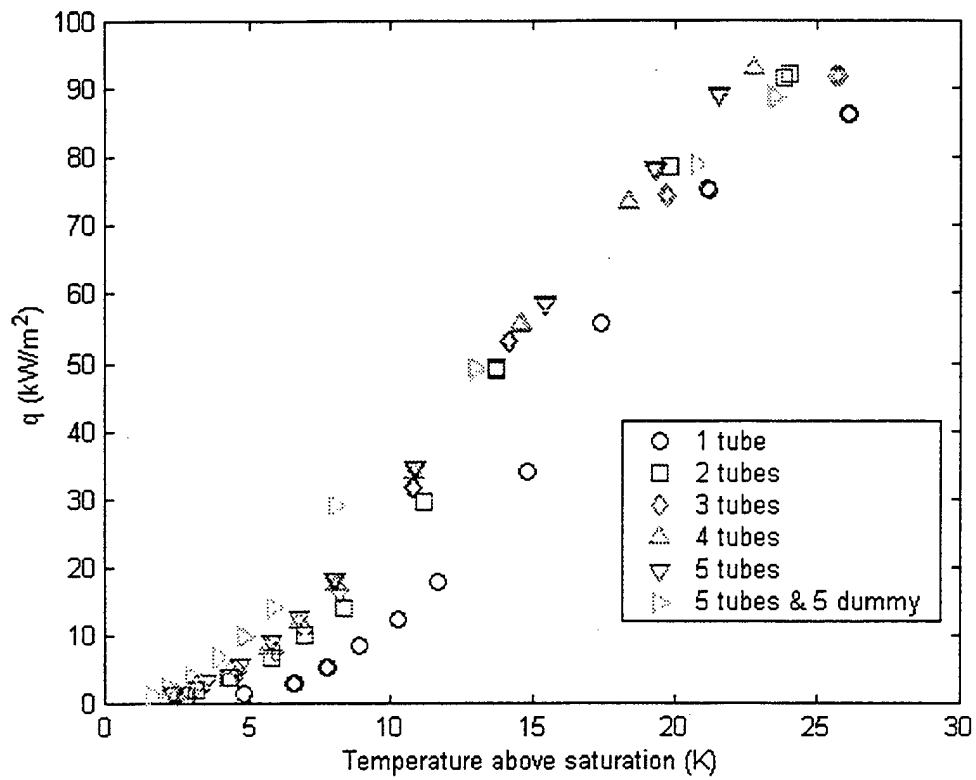

Figure 17: Heat Flux vs. Temperature Above Saturation for Different Numbers of Active Tubes in the Bundle [Ref. 1].

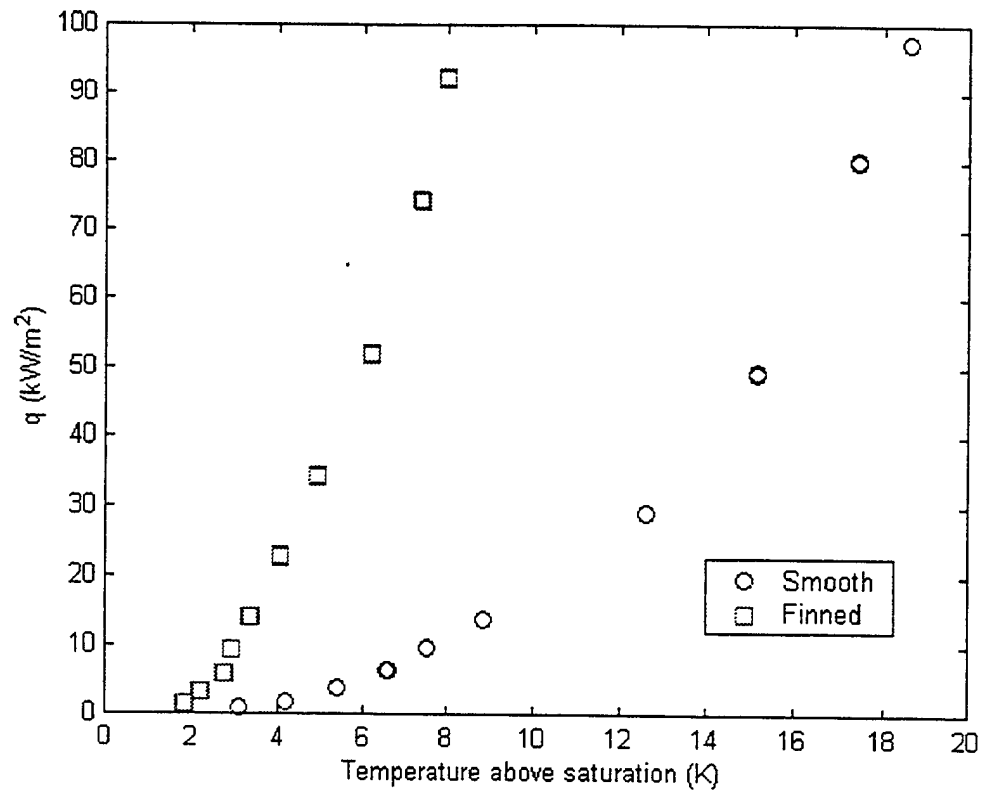

Figure 18: Heat Flux vs. Temperature Above Saturation for Different Configurations [Ref. 1].

Table 4: Average % Error (Over All T) for Every Arrangement of the Smooth Configuration.

| Active Tubes ↓ % Oil → | 0 | 1 | 2 | 3 | 6 | 10 |
|--------------------------|-------|-------|-------|-------|-------|-------|
| 1 | 0.787 | 2.06 | 2.19 | 1.71 | 0.947 | 0.624 |
| 2 | 0.399 | 1.19 | 1.84 | 3.44 | 3.71 | .351 |
| 3 | 2.03 | 0.384 | 0.881 | 2.76 | 0.955 | 0.498 |
| 4 | 0.926 | 0.529 | 3.10 | 0.842 | 2.58 | 1.59 |
| 5 | 1.43 | 0.478 | 1.69 | 0.934 | 0.125 | 1.78 |
| 5 & Dummies | 4.14 | 0.675 | 1.17 | 1.51 | 1.10 | 1.36 |

Table 5: Average % Error (Over All T) for Every Arrangement of the Finned Configuration.

| Active Tubes ↓ % Oil → | 0 | 1 | 2 | 3 | 6 | 10 |
|--------------------------|------|------|------|------|------|------|
| 1 | 9.36 | 2.69 | 2.64 | 3.08 | 2.98 | 3.48 |
| 2 | 2.10 | 1.37 | 3.77 | 4.64 | 3.64 | 2.68 |
| 3 | 1.11 | 1.66 | 2.17 | 1.84 | 3.91 | 1.96 |
| 4 | 1.57 | 1.76 | 5.05 | 2.47 | 4.95 | 2.27 |
| 5 | 2.54 | 3.21 | 1.88 | 5.72 | 6.23 | 4.40 |
| 5 & Dummies | 2.88 | 3.96 | 5.21 | 2.47 | 7.20 | 3.51 |

Using the Marto/Anderson data as the target, the neural network is able to provide accurate results. The network is trained with one set of data. In order to test its ability to predict a system's behavior, a different set of input is given to the network and the output of the network is compared to other data withheld from the training set.

1. Temperature Above Saturation

Data was randomly removed from the set and the network was trained with the partial data set. With the input portion of the unused data (the temperature above saturation ΔT , the percent oil in the refrigerant, the number of active tubes, and whether the tubes are finned or staggered) was then used as input to the trained network. The

output portion (the heat flux, q) was used to compare to the output produced by the network. The results are shown in Figs. 19 and 20.

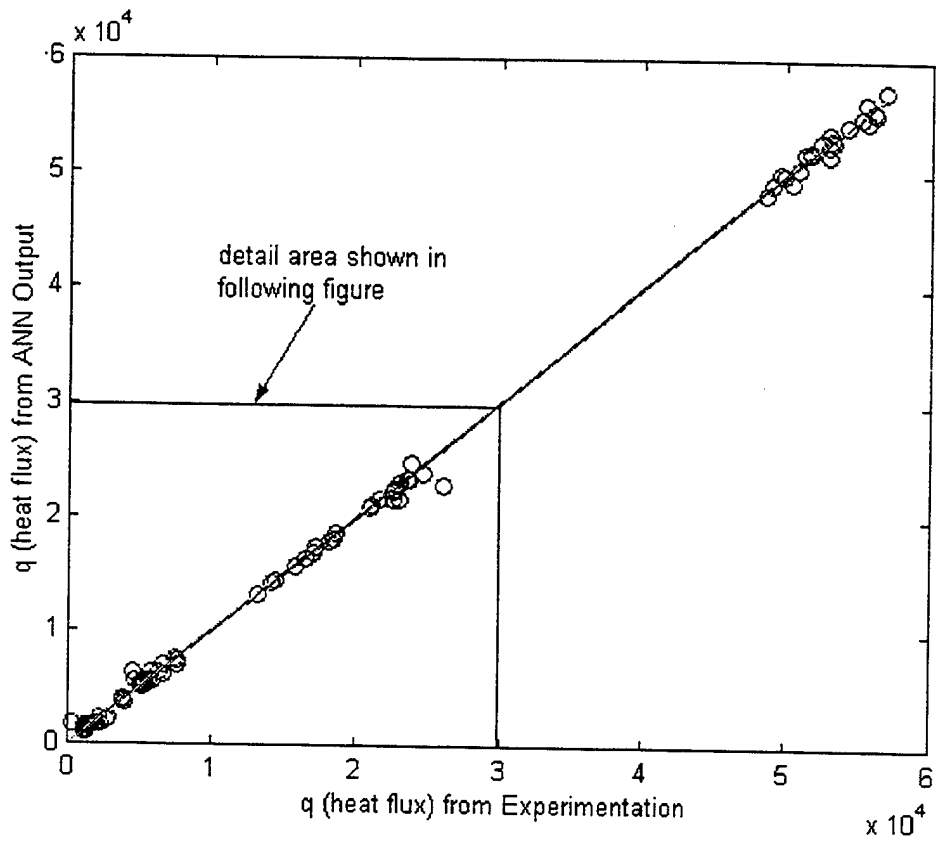

Figure 19: Plot of the Output of the ANN vs. the Experimentation for Different Temperatures Above Saturation.

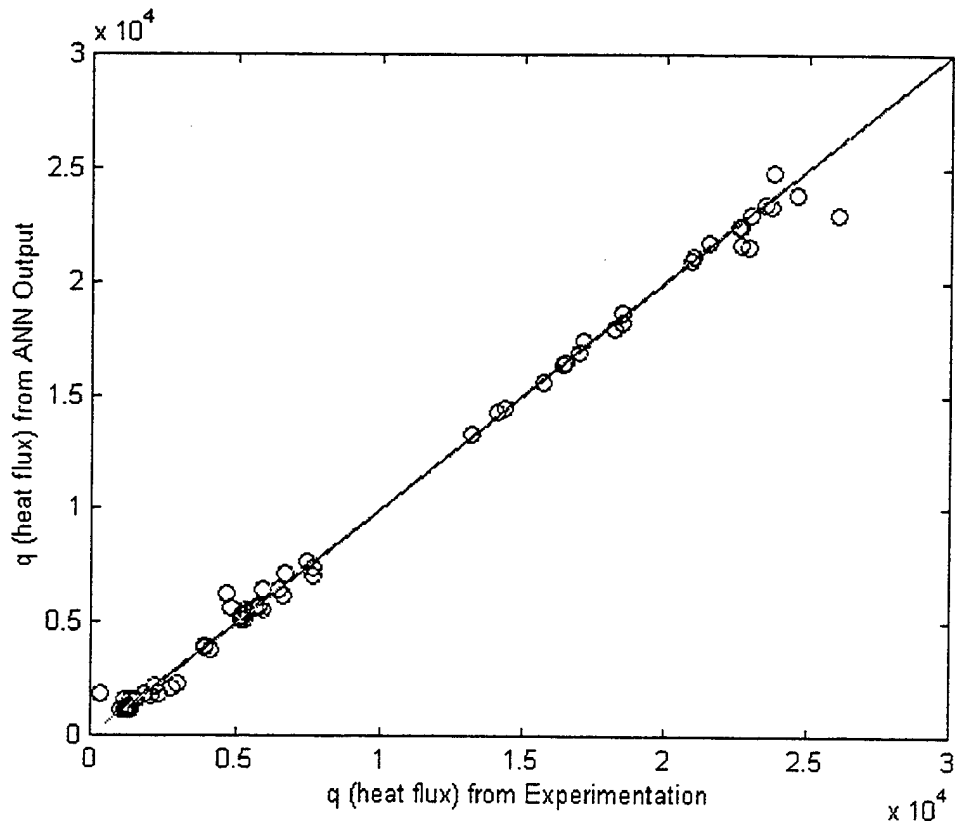

Figure 20: Plot of the Output of the ANN vs. the Experimentation Shown in Detail.

2. Percent Oil Content

Figure 21 shows that the network could make accurate predictions given percent oil values different from those with which it was trained. Since there are four inputs, the plot displays the output of the neural network versus what the Marto/Anderson data would provide. A perfect correlation would produce a 1:1 ratio (a 45° line). The output shown in Fig. 21 was attained by training the network without any input that included Oil %=3. The data with Oil %=3 was then input into the trained network.

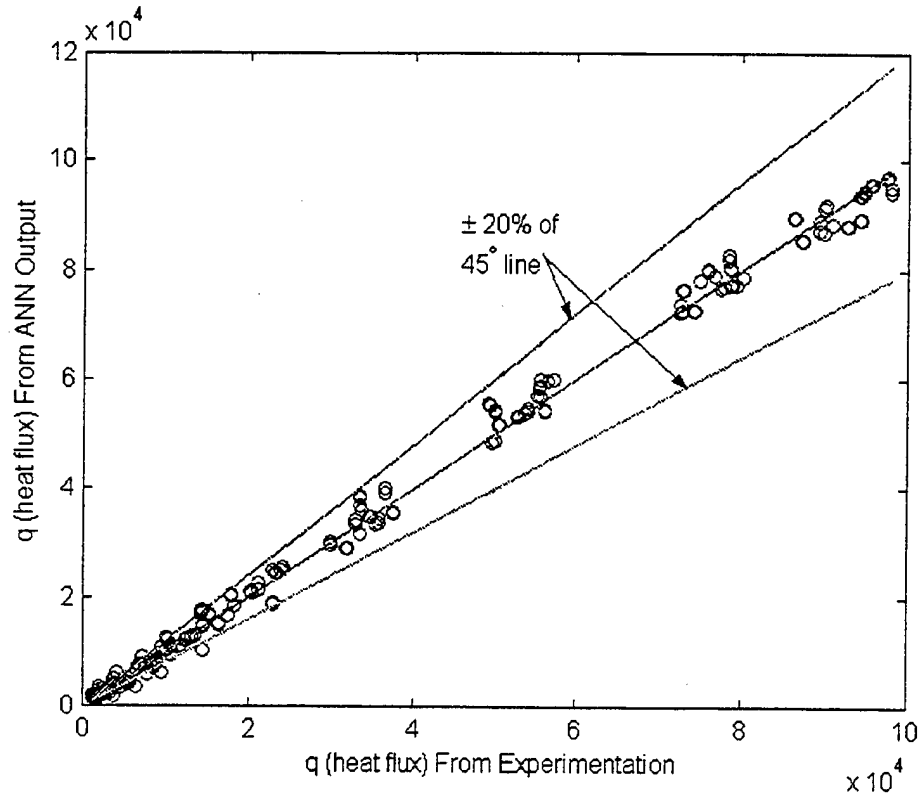

Figure 21: Plot of the Output of the ANN vs. the Experimentation for Different Oil % Values.

3. Number of Active Tubes

Figure 22 shows that the network could make accurate predictions given number of active tube values different from those with which it was trained. Since there are four inputs, the plot displays the output of the neural network versus what the Marto/Anderson data would provide. A perfect correlation would produce a 1:1 ratio (a 45° line). The output shown in Fig. 22 was attained by training the network without any input that included Active Tubes=3. The data with Active Tubes=3 was then input into the trained network.

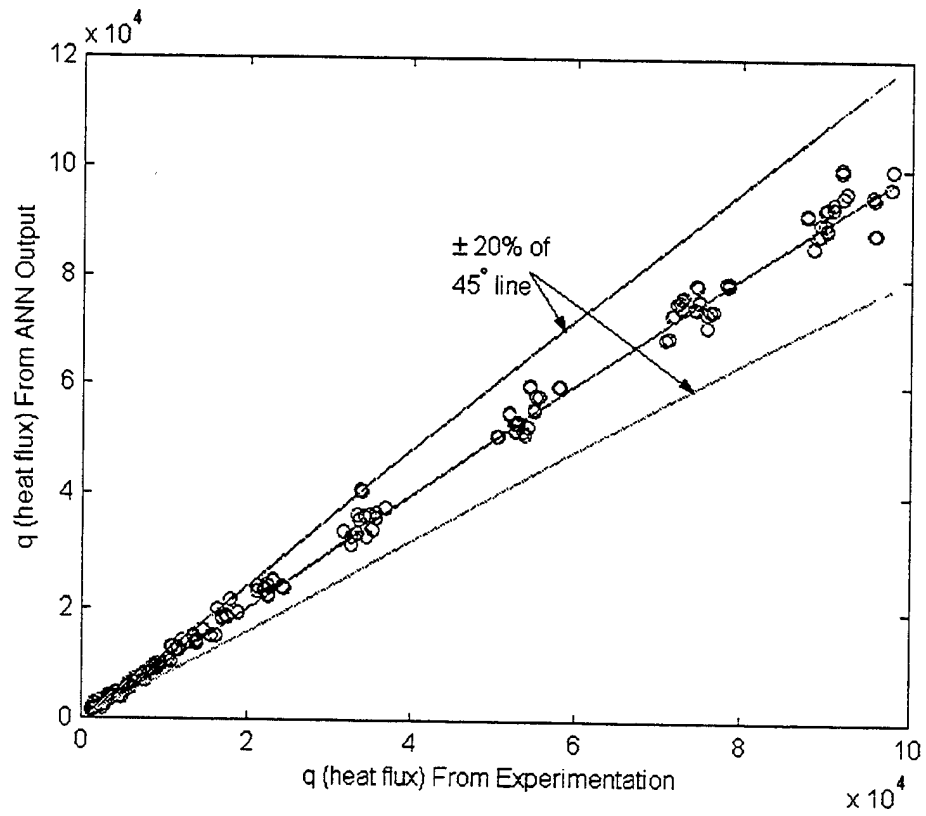

Figure 22: Plot of the Output of the ANN vs. the Experimentation for Different Numbers of Active Tubes.

V. CONCLUSIONS & RECOMMENDATIONS

A. CONCLUSIONS

Through the correlation of complex data, it has been shown that the neural network technique is a viable method for thermal fluid correlations. From the outset of this study, the objective has been to develop a better method of correlating data. With errors as low as or lower than the estimated error in the data itself, the neural network technique displays its potential for complex systems. No longer should 20% error be acceptable for correlations. No assumptions were made in the correlation that limits its use. This allows for a correlation that can have widespread use with confidence. Finally, the correlation involved no "hit-or-miss technique" of development. The weights and biases of the neural network are adjusted iteratively giving a correlation without any equation.

B. RECOMMENDATIONS

1. A more powerful computer could develop extremely accurate correlations for even more complex data sets. Larger data sets could be inputted into network and a more exact correlation could be found.
2. A study could be done on the amount of data necessary to produce worthwhile results. Data could be introduced datum by datum. Results of the accuracy for each step would provide this information.

3. The area of prediction of thermal fluid parameters can eventually be completely understood by neural networks. The area of control can be developed for many thermal fluid machines.
4. Effort should be made to make the neural network technique more widely known and studied at an earlier part of the student's career, as the future of heat transfer may very well involve neural networks.

LIST OF REFERENCES

1. Anderson, C.L., "Nucleate Pool Boiling Performance of Smooth and Finned Tube Bundles in R-113 and R-14/oil Mixtures," Master's Thesis, Naval Postgraduate School, Monterey, California, June 1989.
2. Incropera, F.P. and DeWitt, D.P., *Fundamentals of Heat and Mass Transfer, Fourth Ed.*, John Wiley & Sons, New York, 1996.
3. Sen, M. and Yang, K.T., "Applications of Artificial Neural Networks and Genetic Algorithms in Thermal Engineering," Section 4.24, pp. 620-661, *The CRC Handbook of Thermal Engineering*, (editor) Kreith F, 2000.
4. Haykin, S., *Neural Networks: A Comprehensive Foundation*, Second Ed., Prentice Hall, Upper Saddle River, New Jersey, 1999.
5. Pierson, O. L., "Experimental Investigation of the Influence of Tube Arrangement on Convection Heat Transfer and Flow Resistance in Cross Flow of Gases Over Tube Banks," *Trans. A.S.M.E.* vol. 59, October, 1937, paper PRO-59-6.
6. Huges, E.C., "Experimental Investigation of Effects of Equipment Size on Heat Transfer and Flow Resistance in Cross-Flow Tube Banks," *Trans. A.S.M.E.*, vol. 59, October, 1937, paper PRO-55-7.
7. Demuth, H. and Beale M., "Neural Networks Toolbox: For Use With MATLAB®," Version 3, The Mathworks, Inc., Natick, Ma, 1998.
8. Grimison, E.D. "Correlation and Utilation of New Data on Flow Resistance and Heat Transfer for Cross Flow of Gases Over Tube Banks," *Trans. A.S.M.E.*, vol. 59, October, 1937, paper PRO-59-8.
9. Jambunathan, K., Hartle, S.L., Ashforth-Frost, S. and Fontama, V.N., "Evaluating Convective Heat Transfer Coefficients Using Neural Networks", *International Journal of Heat and Mass Transfer*, 1996, Vol. 39, No. 11, pp. 2329-2332.
10. Lavric, D., Lavric, V. and Woinaroschy, A., "Designing Fin Heat Exchanger With A Neural Network," *Revue Roumaine de Chimie*, 1995, Vol. 10, No. 2, pp. 561-565.
11. Huang, S.-H. and Nelson, R.M., "Delay Time Determination Using An Artificial Neural Network," *ASHRAE Transactions*, 1994, Vol. 100, No. 1, pp. 831-840.
12. Ding, Y and Wong, K.V., "Control Of A Simulated Dual-Temperature Hydronic System Using Neural Network Approach," *ASHRAE Transactions*, 1990, Vol. 96, Part 2, pp. 727-732.

[THIS PAGE INTENTIONALLY LEFT BLANK]

INITIAL DISTRIBUTION LIST

1. Defense Technical Information Center.....2
8725 John J. Kingman Rd., STE 0944
Ft. Belvoir, Virginia 22060-6218
2. Dudley Knox Library.....2
Naval Postgraduate School
411 Dyer Rd.
Monterey, California 93943-5101
3. Naval/Mechanical Engineering Curricular Office, Code 34.....1
Naval Postgraduate School
Monterey, California 93943-5101
4. Professor Matthew D. Kelleher.....3
Mechanical Engineering Department, Code ME/KK
Naval Postgraduate School
Monterey, California 93943-5101
5. Professor Mihir Sen.....1
University of Notre Dame
Department of Aerospace and Mechanical Engineering
Notre Dame, IN 46556
6. Professor K.T. Yang.....1
Department of Aerospace and Mechanical Engineering
University of Notre Dame
Notre Dame, IN 46556
7. Professor Paul Marto.....1
Mechanical Engineering Department, Code ME/MX
Naval Postgraduate School
Monterey, California 93943-5101
8. ESN Thomas J. Cronley.....2
6905 North 2200 West Suite 7-F
Park City, UT 84098