

5947

PP

RECORD  
COPY

MAIN FILE

OTS:60-41,693

JPRS: 5947

31 October 1960

INPUT AND OUTPUT OF INFORMATION IN  
HIGH-SPEED DIGITAL COMPUTERS

By N. V. Trubnikov

- USSR -

RETURN TO MAIN FILE

DISTRIBUTION STATEMENT A  
Approved for Public Release  
Distribution Unlimited

Reproduced From  
Best Available Copy

DTIC QUALITY INSPECTED 4

20000724 119

Distributed by:

OFFICE OF TECHNICAL SERVICES  
U. S. DEPARTMENT OF COMMERCE  
WASHINGTON 25, D. C.

Price: ~~\$1.25~~

U. S. JOINT PUBLICATIONS RESEARCH SERVICE  
205 EAST 42nd STREET, SUITE 300  
NEW YORK 17, N. Y.

JPRS: 5947

OSO: 4688-N/E

INPUT AND OUTPUT OF INFORMATION IN  
HIGH-SPEED DIGITAL COMPUTERS.

[Following is the translation of an article by N. V. Trubnikov entitled "Vyvod i Vyvod Informatsii v Bystrodeystvuyushchikh Tsifrovyykh Vychislitel'nykh Mashinakh" (English version above) in Avtomaticheskoye Upravleniye i Vychislitel'naya Tekhnika (Automatic Control and Computer Technique), Moscow, 1958.]

INFORMATION CARRIERS. Used most widely at the present time' as the carriers are the punch cards, punch tape and magnetic tape. Used considerably less widely are the magnetic wire and the cine-film.

Basically, the punch cards and punch tape are equivalent and their application in the computers is explained by the availability of the punch card thoroughly investigated and widely used in the calculating and analyzing machines and also by the availability of the telegraph punch tapes. The equipment for these carriers differs little from the devices which have already been used for several decades.

The comparatively recently developed technique of sound record-

ing on magnetic tape has a number of advantages in comparison with the perforation and therefore, it has secured wide application in the computer technique. Wire recording is characterized by some design disadvantages and is little used. Recording on the cine-film has not obtained wide application either owing to the inconvenience of working in darkness (when recording), the duration of the film processing, the impossibility of erasing and repeating the recording. At the same time, owing to its mechanical strength the cine-film may be successfully used for program recording with repeated cyclical feeding into the machine. In this case the program is recorded on the film by the perforation method.

Included among the requirements which a carrier has to meet should be the low cost, small size, long life and the feasibility of repeated use, inerasability of the recording during long storage, the feasibility of easy checking of the recording and of the correction of incorrect recording, reliability of reading and also the feasibility of the assembling a complete set of the initial documents from separate pieces.

The term "carrier size" should be understood as its geometrical dimension (length, area, volume) related to a unit of information, for example to one binary digit. However, it is more convenient to use the inverse magnitude - "the recording density" - defined as the number of digits recorded on a unit of length, area or volume.

The choice of the carriers depends also on the characteristics



of the equipment being used.

**PUNCH CARDS.** Up to 960 binary digits or 24 numbers can be set on one punch card. In practice, from one to twelve numbers are set on a punch card. In addition to technical difficulties, the incomplete utilization of the punch cards is explained by the necessity of putting on them the supplementary information - the sequence number of the card, the symbol of the problem, etc. (Figure 1 and 2).

When recording twelve numbers, the maximum density on the punch card comprises:

$$\frac{960}{18.74 \cdot 8.25} = 6.34 \frac{\text{digits}}{\text{cm}^2}, \text{ or } \frac{6.34}{0.018} = 355.2 \frac{\text{digits}^1)}{\text{cm}^3}$$

The blank and the filled-out punch cards can be stored a very long time when definite humidity and temperature are maintained in the storage space. The information can be read several hundred times without appreciable change in the quality of the punch card during this process.

The reading is accomplished by the method generally used in the calculating-analytic technique: by the contact brushes feeling through the punched holes (Figure 3) or with the aid of photocells or photo-disks. In both cases the reliability of reading is sufficiently high.

The correctness of the perforations is checked visually or with the aid of devices. The incorrect perforations cannot be changed.

1) According to GOST (All-Union State Standards) 6198-52 the dimensions of the punch card are: length  $L=187.4^{+0.1}$ , width  $B=82.5^{+0.1}$ , thickness  $=0.18^{+0.015}$



In this case a new card is perforated which does not present special difficulties since only a small amount of information is put on a single card.

The punch cards are very convenient to assemble in the most diverse combinations. They may be used both for the input of the initial data and for the output of the results of the solution.

Equipment used in the processing of the punch cards is characterized by a relatively high cost and large dimensions. The handling of the punch card devices requires a comparatively frequent intervention on the part of the operator since the capacity of a single supply of the punch cards in the existing designs does not exceed one thousand cards. The maintenance technique is sufficiently simple. The setting-up, inspection and repairs do not present special difficulties.

The maximum efficiency of the automatically operated devices during punching comprises 100 cards per minute, or 15 to 20 numbers per second.

The reading rate when using photo-diodes instead of brushes can be brought in practice to 900 cards per minute or 180 numbers (commands) per second. The rate of printing amounts in the case of standard equipment to 1-2 numbers per second.

The operational reliability of the devices is sufficiently high. The stoppage of the devices for 0.5-1 hours in every 24-hour period is necessary for preventive maintenance.

All devices used for processing the cards may be reduced to two types - reading devices and punching devices having different electric circuits. This facilitates the standardization of these devices.

Among the drawbacks of the devices for work with the punch cards should be included the impossibility of repeated reading or of changing the reading sequence without the intervention by the operator.

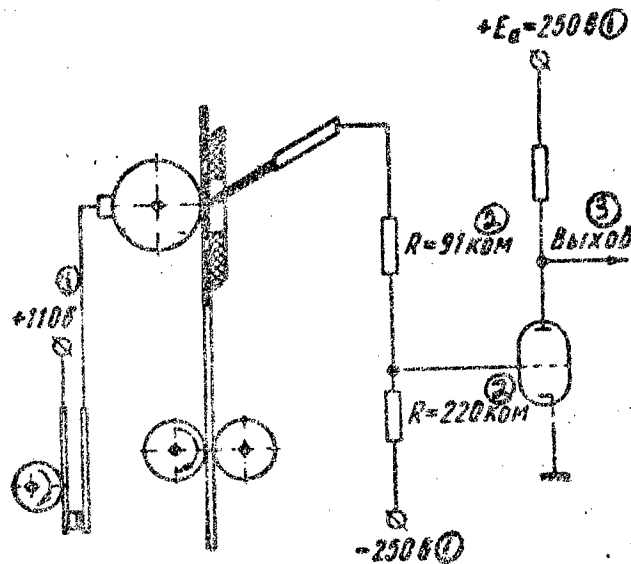

Figure 3. Reading the numeric material from the punch cards with the aid of brushes.

- (1) - volts
- (2) - kilohms
- (3) - Output

**PUNCH TAPE.** The punch tapes used in computer technique differ chiefly in the width on which the maximum number of perforations in the lateral direction depend (the number of channels).

Tapes of 5-6 millimeters in width (one channel) to 182 millimeters width (80-90 channels) are used. Most widely used are the tapes of 12 millimeters in width for two channels, 17.5 millimeters - for 5 channels and 35 millimeters for 12 channels.

Storage conditions, the number of times a tape can be made use of and the feasibility of restoring the information from damaged tapes are about the same as in the case of punch cards.

The correctness of punching is easily checked automatically or visually. The correction or a change in the perforations of a tape are possible by means of second punching of another tape and by gluing together if appropriate devices are adapted for the processing of the tapes glued together. If however, the devices are not adapted for this, then the tape has to be punched once more (this is an automatic operation).

The reading from the punch tapes may be accomplished by the same methods as in reading from the punch cards (Figure 4). However, because of the lower mechanical strength of the punch tape in comparison with the punch card, and because of the great difficulties of restoring when damaged, the use of the contact brushed is permissible only when the number of times the tape is to be used is small.

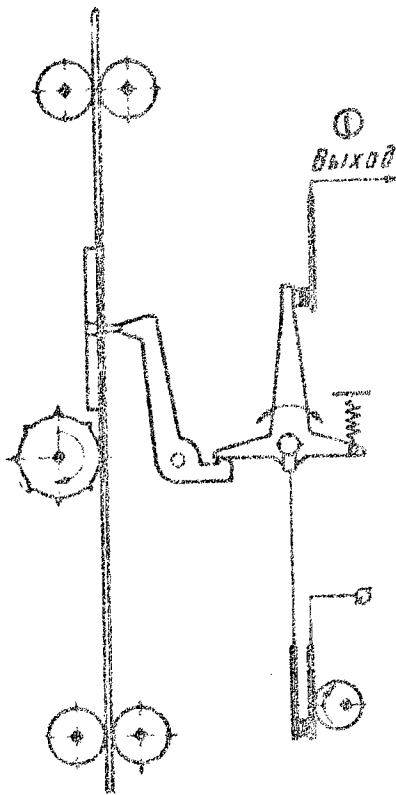

Figure 4. Reading numeric material from a punch tape with the aid of contact feelers.

(1) - Output

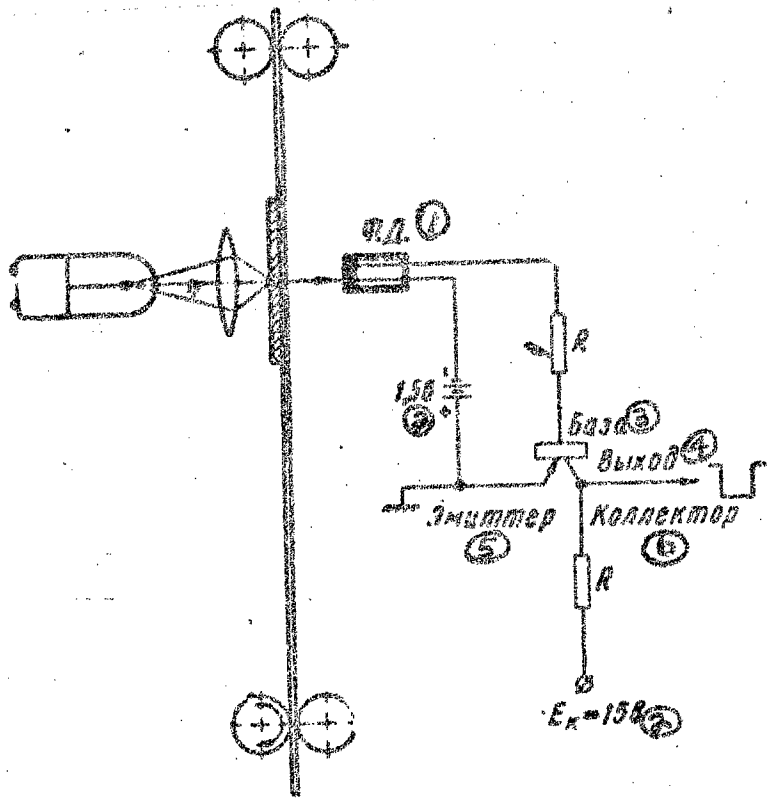

Figure 5. Reading numeric material from a punch tape with the aid of photo-diodes.

- (1) - F.D. - photo-diode
- (2) - volts
- (3) - Base
- (4) - Output
- (5) - Emitter
- (6) - Collector

Standard telegraph equipment provides for the start-stop movement of the tape, the pressing of the brush or feeler against the tape taking place only during the stop period.

The complexity of the equipment depends on the width of the tape. The equipment used for very wide tapes does not differ substantially from the equipment for punch tapes. The narrow tapes are processed with the aid of equipment similar to the telegraph equipment. The cost of this equipment is comparatively low and the dimensions are small. The electric energy consumption amounts to about 30-50 watts per device. The setting-up, inspection and repairs do not present special difficulties. The efficiency of the automatic devices operating with telegraph punch tapes comprises 20-30 perforations per second. The rate of reading with the aid of photocells or photo-diodes F.D. (Figure 5) (contactless reading) may reach 5-7 meters per second which in the case of a five-channel tape and with forty binary digits in a number comprises 150-200 numbers (10,000 digits) per second while the rate of printing is 7-8 decimal numerals per second.

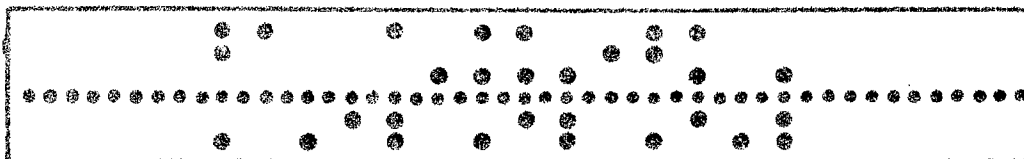

Figure 6. A sample of punch tape showing number codes.

Among the advantages of this equipment should be also included the high reliability of the operation and the feasibility of repeated automatic input of material by means of reversing or by means of gluing the tape into a ring. The disadvantage is the complication of the design when increasing the width of the tape.

The arrangement of the numeric material on a five-channel tape is shown in Figure 6. One digit of a decimal number expressed in binary code is arranged on each line.

MAGNETIC TAPE AND MAGNETIC WIRE. The recording of number codes on a magnetic tape or wire is accomplished by means of local magnetizing of separate parts of the carrier.

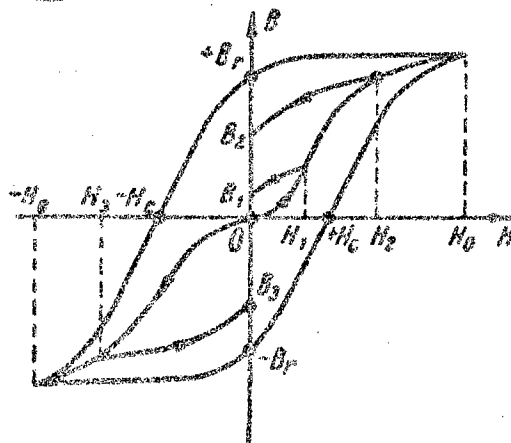

Figure 7. Relation of the residual induction  $B$  to the magnetic field intensity  $H$  for ferro-coating of the magnetic tape.

The principle of magnetic recording is based on the property of some ferromagnetic materials to retain the magnetized state after the removal of the magnetic field. Included among such materials are the magnetite  $\text{Fe}_2\text{O}_3$  ( $\gamma$ -phase), cobaltic oxide  $\text{Co}_2\text{O}_3$  and a number of others. The following relation is characteristic of these materials -  $B=f(h)$  (Figure 7).

The physical medium characterized by such a relation may assume a number of stable discrete states of the residual induction  $B_1, B_2, B_3 \dots$  each of which corresponds to the value of the external action of the magnetic field having the intensity  $H_1, H_2, H_3 \dots$ . However, it is very difficult to fix the boundaries of these states of the medium in practice.

It is possible to create and distinguish three magnetic states of a medium with the simplest methods:

- 1) The medium is demagnetized ( $B_{\text{res}} \approx 0$ ).
- 2) The medium is magnetized in the positive direction ( $B_{\text{res}} = +B_r$ ).
- 3) The medium is magnetized in the negative direction ( $B_{\text{res}} = -B_r$ ).

Such magnetic media may be used in the devices for the storage of the codes of the numbers the base of the notation scale of which is equal to or smaller than three. The carrier is usually made in the form a ferromagnetic tape or drum. The ferromagnetic tape represents a thin (40-100 micromillimeters) acetyl cellulose base to

which ferro-coating has been applied.

The recording of the electric pulses and their reproduction are accomplished with the aid of special magnetic heads (Figure 8). The head consists of winding and a magnetic circuit. It has two gaps - the operating gap  $\delta$  and the back gap  $\delta_1$ . The back gap should be as small as possible since its presence determines the decrease in the efficiency of the reproducing heads and an increase in the current in the recording heads.

The current pulse delivered to the winding of the recording magnetic head creates in the operating gap a field which is proportional to the magnetizing ampere-turns (Figure 9) and the parts of the carrier passing at this instant underneath the operating gap become magnetized. Thus, the pulse is fixed on the carrier in the form of a magnetic imprint having definite parameters.

The combination showing zero and unity on a magnetic carrier represents a number code. The discrete states of the parts of a magnetic carrier are secured by different methods. Used most widely at the present time are two-level recording, three-level recording and recording on two levels without a space between the numeric images.

In the case of two-level recording, the tape is magnetized in a definite direction. For this purpose, a constant magnetic field having intensity  $H_0$  (Figure 10) is applied to it with the aid of the erasing magnetic head. This magnetic state corresponds either to zero

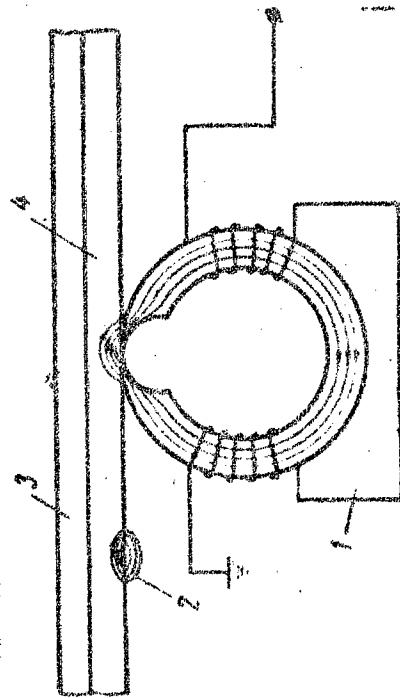

Figure 9. Recording of pulses on a magnetic tape;

- 1 - magnetic head; 2 - magnetic imprints;
- 3 - base; 4 - ferromagnetic coating.

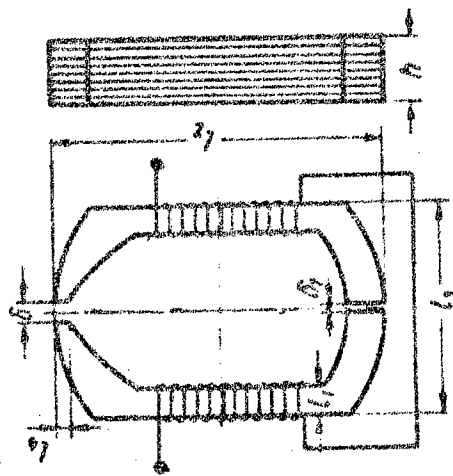

Figure 8. Universal magnetic head.

or to the absence of a numeral. For the representation of unity, the tape is subjected to the action of the pulse of the external magnetic field having intensity  $H_0$  by means of the recording magnetic heads. As the result of this, a magnetic imprint forms on the tape, the maximum residual induction of the imprint reaching the value of  $B_r$ .

When employing the two-level recording, there arises the necessity of distinguishing the state corresponding to zero from the state which indicates the absence of a numeral on a given portion of the tape.

All these different mathematical states are characterized by the residual induction of the tape, for example,  $+B_r$ . It is possible to draw the distinction between them with the aid of the so-called marking pulses recorded on a parallel channel. The image of the numbers consisting of unities and zeroes is accompanied without fail by marking pulses which are similar to the image of unity.

It is known that the electromotive force developing in the winding of the reproducing magnetic head is proportional in time to the rate of the magnetic flux passing along its magnetic circuit:

$$e = A \frac{d\Phi}{dt} = A \frac{d\Phi}{dx} v, \quad (1)$$

where  $v$  is the speed of the motion of the tape relative to the magnetic heads;

$A$  - factor of proportionality.

The rate of change in the induction flux of the magnetic imprint when this method is used is higher in comparison with other

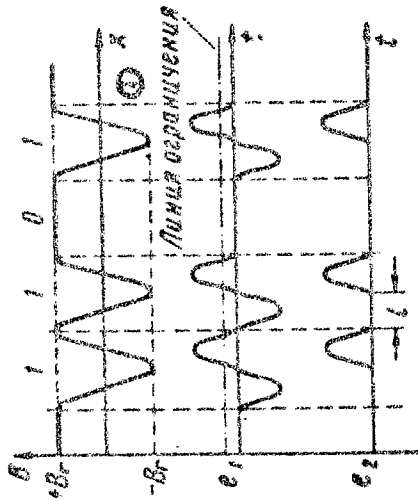

Figure 10. Two-level recording of number codes on a magnetic tape:  
 $e_1$  - emf. developing in the winding of the reproducing head; the shaped code pulses. (1) - Line of demarcation

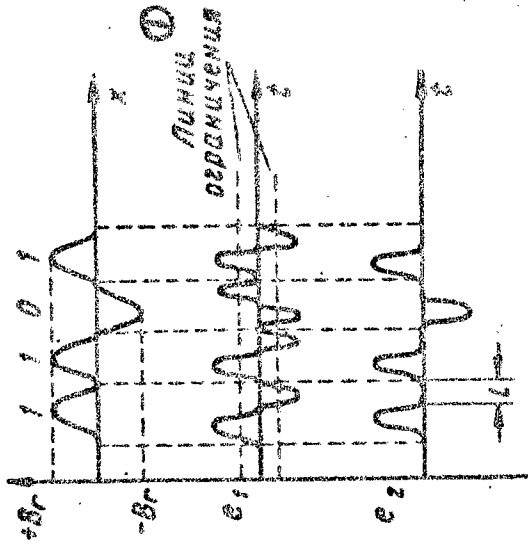

Figure 11. Three-level recording of number codes on a magnetic tape.  
 (1) - Lines of demarcation.

methods. The length of the magnetic imprint is also greater which decreases the density of the recording.

The three-level recording (Figure 11) is characterized by three states of the residual intensity of the tape magnetization. The absence of a numeral is represented by the zero remanent induction in the case when the tape is demagnetized. Unity is recorded by means of magnetizing the tape in one direction, for example to the magnitude  $+B_r$ , and zero is recorded by means of magnetizing in the opposite direction correspondingly to  $-B_r$ . With this method of recording the necessity of marking pulses is eliminated.

With other conditions being equal, the length of the magnetic imprint when using this method of recording is 20-30% less than the length of the magnetic imprint obtained with two-level recording and the amplitude of the signal being reproduced is approximately 30% smaller.

Owing to the circumstance that the magnetic material is in the demagnetized state, the amplitude of the pulses originating because of the magnetic tape defects, drops sharply. This considerably increases the "signal-to-interference" ratio.

The two-level recording without an interval between the numeric images is characterized by two distinct states of the tape, these states representing groups of unities and zeroes (Figure (12)).

When reproducing the code recorded by this method, it is necessary not only to distinguish the zero state from the absence-of-a-num-

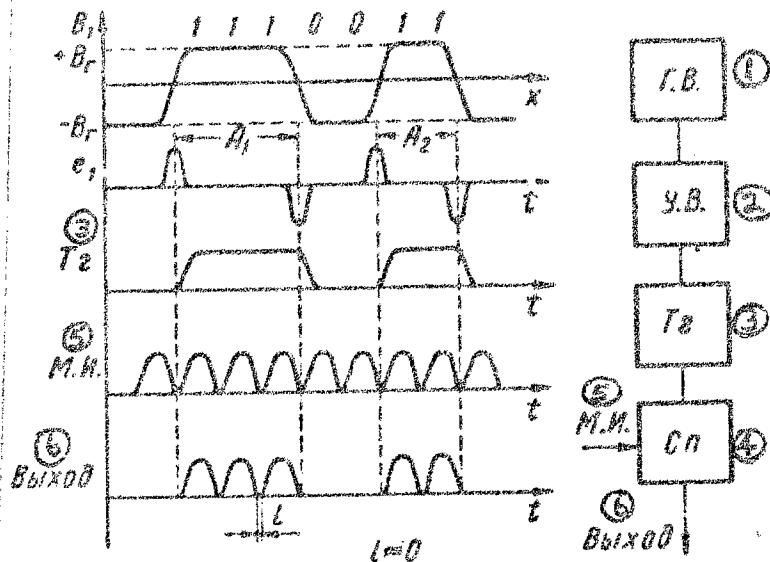

Figure 12. Two-level recording of number codes on a magnetic tape without a space between the numerals:

- (1) - Г.В. - Reproduction head;
- (2) - У.В. - Reproduction amplifier;
- (3) - Тг - Trigger;
- (4) - Сп - Coincidence circuit;
- (5) - М.И. - Marking pulses;
- (6) - Output.

ber state but it is also necessary to know the number of unities and zeroes corresponding to the length of the magnetized portion of the tape. This is achieved with the aid of the marking signals recorded on a special channel and spaced at intervals equal to the spacing of the recording of numbers (parallel and parallel-series recording) or of the number digits (series recording). The marking pulses can be shaped from both half-waves of the signals being reproduced.

The obvious advantage of this method of recording is that the maximum density of the recording is increased approximately twofold. It should be noted that the advisability of using one or the other method of recording numeric images depends on the concrete conditions of the utilization of the ferromagnetic tapes in the storage devices.

In the overwhelming majority of cases the recording of discrete information on a magnetic tape is accomplished simultaneously along several parallel channels.

The modern magnetic tapes have different widths and a correspondingly different number of channels. The widest tape used in the automatic high-speed digital computers has a width of 125 millimeters and is designed for a simultaneous recording and reading along 50 channels. The narrowest tape has a width of 6.35 millimeters and is designed for 1-3 channels. Most widely used are the magnetic tapes of 17.5 and 35 millimeters in width with parallel-series method of recording the numbers (Figures 13 and 14).

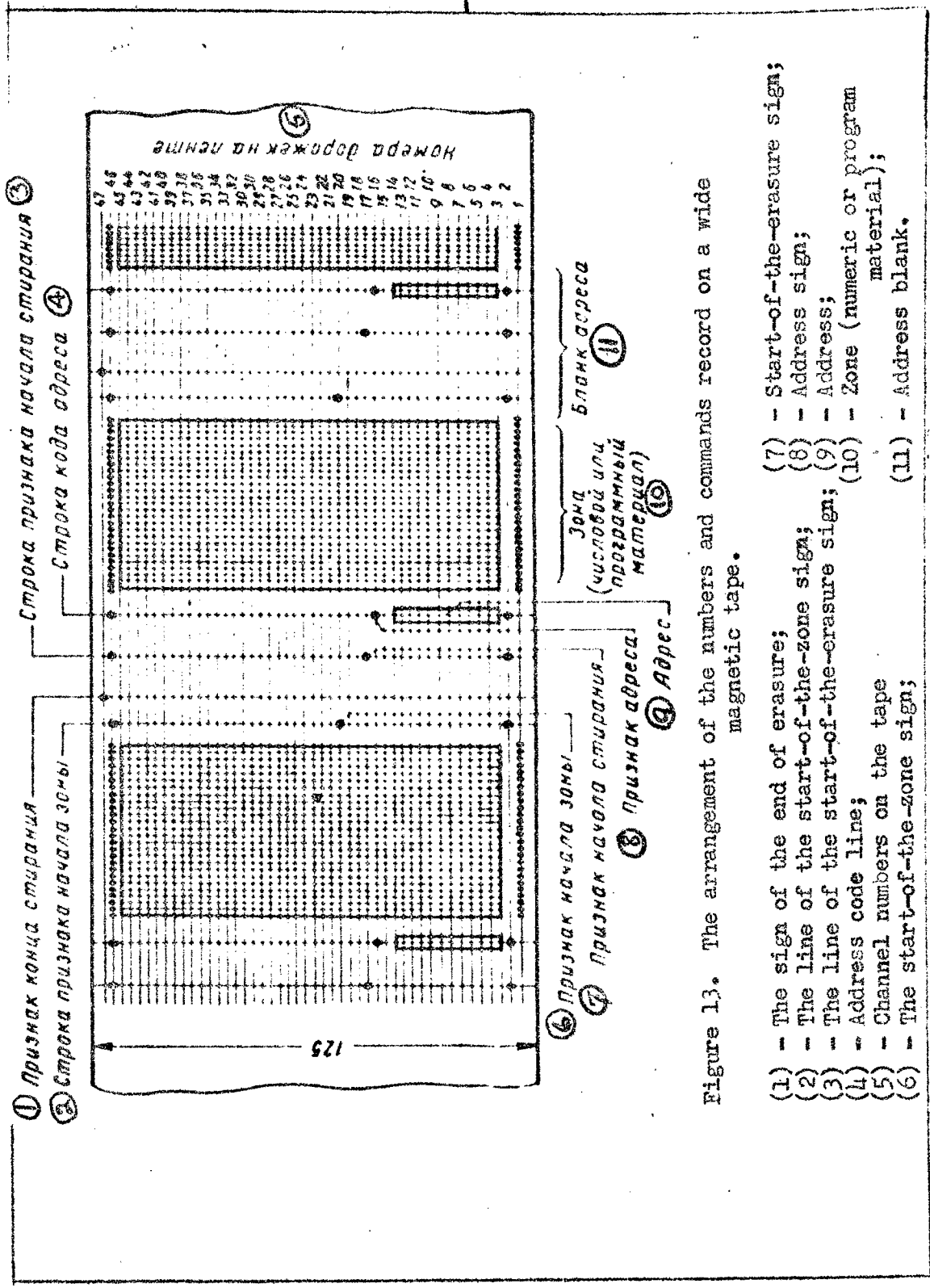

Figure 13. The arrangement of the numbers and commands record on a wide magnetic tape.

- (1) - The sign of the end of erasure;
- (2) - The line of the start-of-the-zone sign;
- (3) - The line of the start-of-the-erasure sign;
- (4) - Address code line;
- (5) - Channel numbers on the tape
- (6) - The start-of-the-zone sign;
- (7) - Start-of-the-erasure sign;
- (8) - Address sign;
- (9) - Address;
- (10) - Zone (numeric or program material);
- (11) - Address blank.

When moved by the tape-winding mechanism, the ferromagnetic tape becomes deformed as the result of the stresses applied to it and as the result of the unavoidable presence of skewing and conicity of the generators of the guide rollers. The deformation of the tape is expressed by the appearance of skewing in the generatrix and in its deflection.

The misalignment of the tape generatrix leads to the development of misalignment of the line  $\alpha$ , and the deflection of the generatrix leads to the deflection of the line, i.e. to the maximum deflection of the magnetic imprints from the line of the row by magnitude  $\delta$ . The bias  $\alpha$  and deflection  $\delta$  change with respect to the magnitude and the sign during the process of the operation of the device (Figure 15).

For recording along many channels, a corresponding number of magnetic heads assembled into a single unit are used. The operating gaps of the magnetic heads assembled into a unit may have deflections from the straight line of the gaps by magnitude  $\pm c$ .

It is very difficult to set the line of the operating gaps of the unit exactly perpendicular to the direction of the tape movement. This leads to the appearance of a bias in the line of the gaps by magnitude  $\pm \gamma$ . The bias is characterized by the angle  $\alpha$  between the direction of the tape movement and the line of the gaps. In some cases the recording is accomplished with the aid of one apparatus and the reproduction - with the aid of another. Sometimes, several units

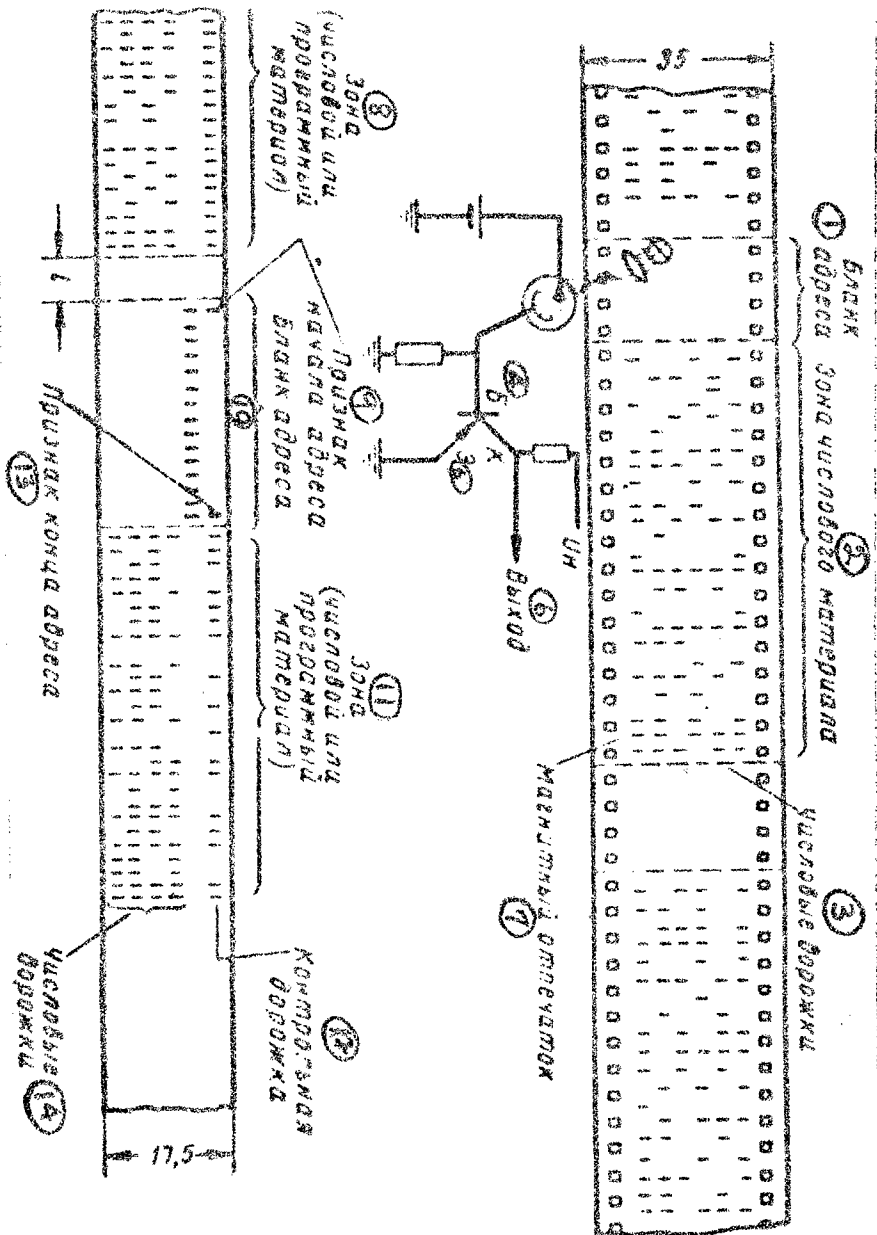

Figure 1b. The arrangement of the numbers and commands recording on a magnetic tape of intermediate width.

- (1) - Address blank; (2) - Zone of numeric material; (3) - Number channels; (4) - B;
- (5) - B; (6) - Output; (7) - Magnetic imprint; (8) - Zone (numeric or program material);
- (9) - The start-of-the-address sign; (10) - Address blank; (11) - Zone (numeric or program material); (12) Control channel; (13) - End-of-the-address sign; (14) - Number channels.

of magnetic heads are mounted on one apparatus, these units reading in series the codes recorded on the tape.

Inaccuracies in the position of the operating gaps  $\epsilon$  in different units differ both with respect to the sign and the magnitude. It is obvious that magnetic-head units proper on different magnetic recording apparatuses cannot be set absolutely identically. As the result of this the above-mentioned inaccuracies will be different for different units. The inaccuracies pointed-out, lead to the appearance of the deformation in the code line by magnitude:

$$\Delta L = \sum \eta + \sum \gamma + \sum \epsilon + \sum c. \quad (2)$$

The deflections of the magnetic imprints on a line produced by the deformations and the bias of the tape by magnitude  $\Delta L$  lead to the decrease in the maximum density of the recording:

$$P_{\max} = \frac{1}{L + \Delta L}, \quad (3)$$

where  $L$  is the length of the magnetic imprint of an electric pulse.

From the experience in designing storage devices with a magnetic tape, it is known that the magnitude of the deformation of the code lines  $L$  increases with the increase in the number of the parallel channels and in the width of the tape. A reduction in the deformation of the code lines is achieved by means of increasing the precision in the manufacture of the components of the tape-winding track,

the magnetic head units and their mounting on the magnetic recording apparatuses. In the modern storage devices the errors in the manufacture and the assembly of the components do not exceed a few tens of microns. In order to reduce the magnitude  $\Delta L$ , it is advisable to use units of the universal magnetic heads for the recording and reproduction of the information from the tape and to increase the mechanical strength of the magnetic tape base.

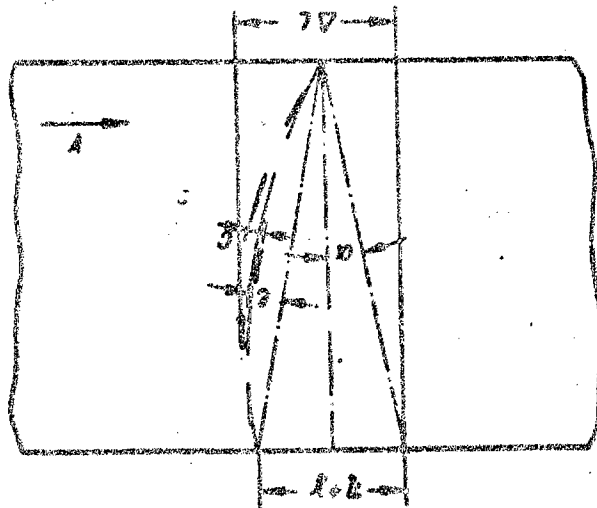

Figure 15. Deformation of the magnetic tape.

The aggregate deformation of the tape resulting from the action of the stresses on it during the movement must not exceed  $5 \pm 10\%$  of the magnitude of the magnetic imprint. The infraction of this condi-

tion leads to a reduction in the maximum density of the recording.

At the present time the electromagnetic parameters of the channel "recording-reproduction" allow the recording of the pulses on the ferromagnetic tape along a single channel with the maximum density of 30-40 pulses per millimeter. However, due to the existence of the above-mentioned inaccuracies in the tape-winding mechanism, in the magnetic head units and also owing to the poor mechanical parameters of the tape in multi-channel recording, it is very difficult to achieve a high degree of density.

It is known that the representation of the number codes may be recorded on the magnetic tape by the parallel, serial or parallel-serial methods. It would seem that the parallel method of recording the information should produce an increase in the operational rate of the storage device by  $n$  times where  $n$  is the number of pulses per line. In reality no such increase in the rate results because of the deformations of the code lines, these deformations increasing with the increase in the tape width. The deformations lead to an increase in the spacing of the recording and consequently, to a decrease in its density.

For a correct choice of the recording method in every concrete case it is necessary to take into account the effect of the mechanical inaccuracies in the equipment of the storage device on the rate, and it is also necessary to take into account the performance reliability of this device.

The reading of the number codes from the magnetic tape is accomplished by means of inducing electric pulses in the magnetic heads, these pulses arriving from the magnetized tape sections travelling past the heads. Afterwards, these pulses are amplified (Figure 16).

The amplitudes of the pulses being read depend on the type of the magnetic tape and on the design of the reading heads and amount to fractions of a millivolt to several tens millivolts. Therefore, both the reading heads and the amplifiers must be well shielded from the action of external electromagnetic fields.

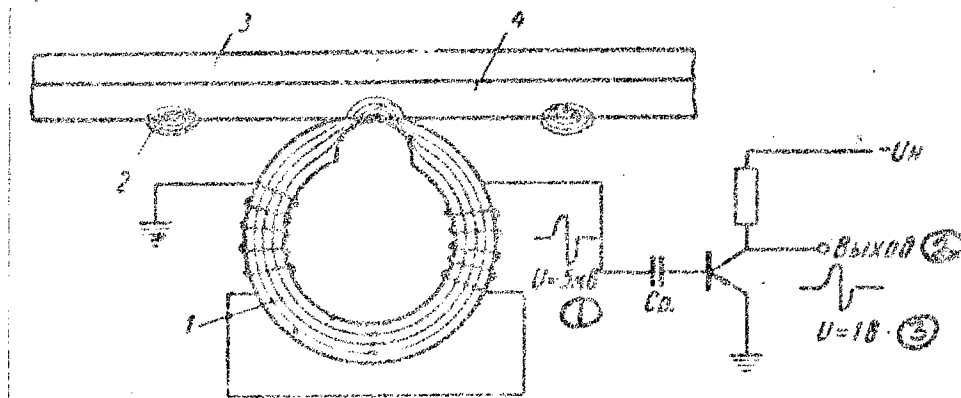

Figure 16. Reproduction of number codes recorded on magnetic tape;

1 - magnetic head; 2 - magnetic imprints; 3 - base;  
4 - ferromagnetic coating.

(1) - millivolts; (2) - Output; (3) - volts.

A substantial drawback of the reading process is the linear dependence of the signal amplitude on the speed of the tape movement. Therefore, not only the upper speed limit is restricted but also the lower speed limit. The upper speed limit depends on the precision in the manufacture of the tape-winding mechanism and the lower speed limit is restricted owing to the inadequate efficiency of the magnetic tapes. The reliability of reading is also affected by those defects of the tape which so far it has not been possible to eliminate; the lack of uniformity in the magnetic properties of the separate portions of the tape; the presence of separate extraneous connections producing a variation in the distance of the tape from the magnetic heads or characterized by magnetic properties different from the rest of the tape surface.

The magnetic heads KMG-2 used heretofore in the computers have the following parameters: the height of the core assembly made of the annealed permalloy  $h=0.6$  millimeters; the width of the channel (of the magnetic mark)  $b=2$  millimeters; the number of the winding turns  $w=200$ ; the width of the operating gap  $\delta=0.040$  millimeters.

With the recording current of 60-70 milliamperes, the output of these heads comprises  $u_{\min}=200$  microvolts and  $u_{\max}=800$  microvolts with the pulse repetition rate  $f=1000$  cycles per second.

The magnetic heads performing simultaneously the recording and reproduction along several parallel channels are combined into a single

unit of magnetic heads with shields being set up between the individual heads.

In one of the design bureaus of the instrument-manufacturing industry there has been developed a design and studies have been made of a magnetic head unit in which zero deflection of the operating gaps is secured in practice.

This unit secures the recording of the electric pulses arriving simultaneously at the magnetic heads windings without deflections from an imaginary ideal line. In the reproduction of the recording by the other units of this design (in the case when the units are replaced)

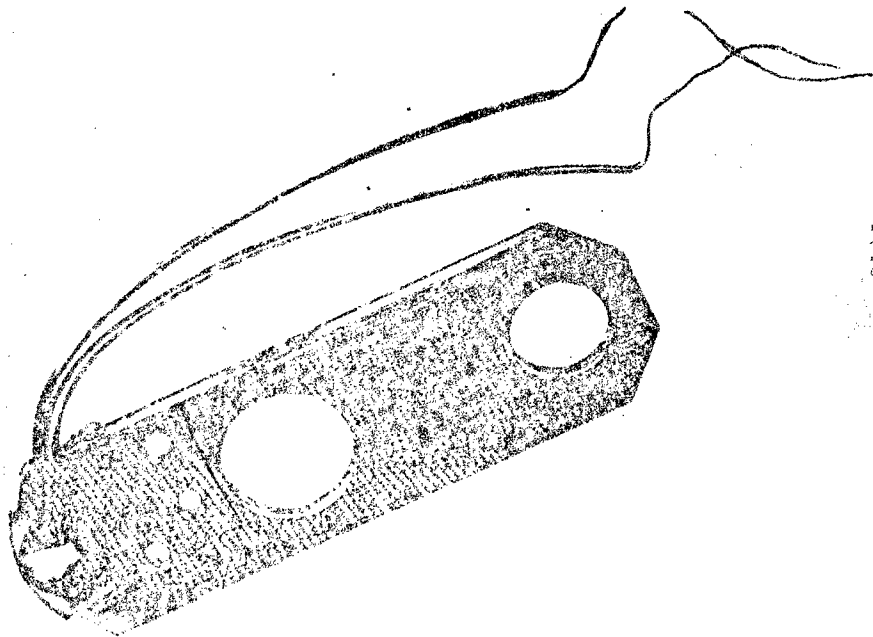

Figure 17. Design of the drop-type magnetic head KMG-2

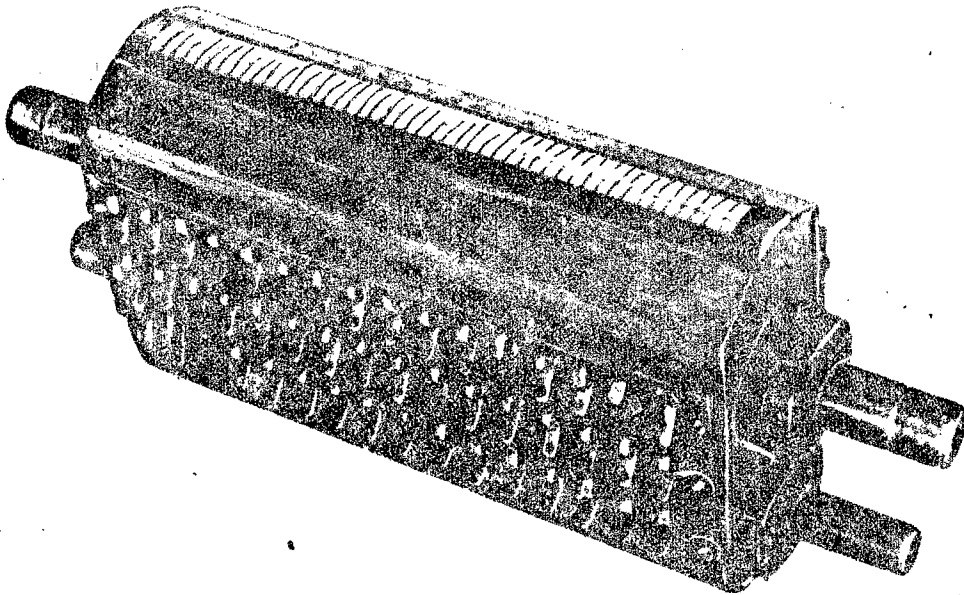

Figure 18. Design of an assembled unit consisting of 47 separate magnetic heads.

or when the tape is transferred from one magnetic recording apparatus onto another, the line pulses are also reproduced simultaneously.

The minimum distance between the adjacent heads of the unit is determined by the magnitude of interference created by the magnetic flux of the heads. When there is a permalloy shield between the heads, the interference does not exceed -50 decibels and this distance is equal to about 1 millimeter. Such a design of magnetic heads secures zero errors with respect to the spacing and position of the operating gaps on one magnetic recording apparatus.

In the table below are shown the results of the study of a unit of heads with different magnetic tapes.

Tested simultaneously with the heads were the magnetic tapes. The tests were conducted at the tape movement speed  $v=1.5$  meters per second and the pulse repetition rate  $f=10,000$  pulses per second.

The studies showed that with different cross sections, the tapes must have a mechanical strength of not less than 5 kilograms related to a tape of 6.35 millimeters in width, and elasticity of not more than 0.1% per unit of length.

The physical and geometrical parameters of the tape must be homogeneous; the presence of extraneous admixtures, impregnations, gluing-together, slight tears, punctures etc. is not allowed.

The physical heterogeneity of the material leads to a change in the remanent induction (when the magnetizing field is constant) in the direction of the tape movement. The geometric heterogeneity shows itself firstly in the concentration and grain sizes of the magnetic powder and, secondly, in the variation of the cross-section of the magnetic layer. The size of the grains must not exceed 0.1 micromillimeters. It is also desirable that the surface of the magnetic tape be polished. When these conditions are satisfied, the amplitude spread of the pulses being read is considerably reduced (at the present time this spread reaches up to 100 - 200%), the amplitude of the signals being read increases by 15 - 20% and the wear of the heads is considerably reduced. The recording density can be brought to 25-30

- 1 - Type of tape;
- 2 - Recording current in milliamperes;
- 3 - Half-wave amplitude in millivolts;
- 4 - Pulse duration in microseconds;
- 5 - Frequency at which the single pulses change to sinusoid, fe in kilocycles per second;
- 6 - Maximum permissible recording density;
- 7 - Tape thickness  $\mu$ .

	1	2	3	4	5	6	7
Type 1 of the Khar'kov Sovmarkhoz Factory No. 3.....		20	12,5	130	8	5,6	60
Type 2 of the Khar'kov Sovmarkhoz Factory No. 3.....		20	30	95	10,5	7	50
Type C of the firm "ACEFA" (German Democratic Republic).....		17	10,5	100	10	6,7	50
Type CH of the firm "ACEFA" (German Democratic Republic).....		17	22	94	10,6	7	50
Type LGS (German Federated Republic).....		18	21	80	12,5	8,3	35

pulses on 1 millimeter. Meanwhile, the Type 1 and 2 ferromagnetic tapes of the Khar'kov Sovnarkhoz Factory No. 3 used at the present time and also the tapes C and CH of the firm "AGFA" do not satisfy completely the requirements demanded and at the present time new types of tapes for the recording of pulses are being developed.

OPERATIONAL CHARACTERISTICS OF THE FERROMAGNETIC CARRIERS. The cost of magnetic tape or wire has no substantial significance because of the feasibility of their repeated use. The recording density on a tape is very great and comprises 100-500 binary digits on 1 cm<sup>2</sup> or 5000-50000 on 1 cm<sup>3</sup> with the tape thickness of 0.05-0.12 millimeters, the recording spacing of 0.5-0.08 millimeters and the channel width of 1-2 millimeters.

With the proper temperature and humidity, the tapes may be stored for several years without losing their properties. The spontaneous erasing or a change in the quality of the magnetic recording is hardly probable during long storage.

Information deposited on the tape or wire may be developed for visual check but this method should not be recommended in normal operation because of its complexity and lack of reliability. For checking the correctness of the recording one may recommend the reproduction of the information recorded on the tape with the subsequent printing of it on paper or recording on punch cards.

The recording on the tape can easily be erased partially or

completely and new recording can be put in its place. The technical difficulties arise when erasing small, precisely bounded portions of the tape. Therefore, groups of material which may be subjected to a simultaneous erasing should be separated by spaces of not less than 3 - 6 millimeters.

The reading from the magnetic materials is accomplished by means of inducing electric pulses in the magnetic heads from the magnetized portions of the tape travelling past the heads and by an appropriate amplification of these pulses.

The magnetic tape may be utilized both for the input of the initial data and for the output of the final results of the solution. The reading of the results from the tape and the printing of them on paper according to the decimal number system, are accomplished with the aid of a printing device placed outside the machine. Magnetic tape is used widely for recording on it those results of a solution which are to be fed into the machine the second time.

Equipment used for the magnetic tapes is essentially similar to the equipment for magnetic sound recording. Only the electric part is considerably different because of the special requirements demanded of it.

The cost depends on the width of the tape and in the case of wide tapes is very high. The dimensions also depend on the tape width and correspond approximately to the dimensions of the machines for punch cards. Electric energy consumption is insignificant.

The handling of the automatic devices is comparatively uncomplicated and is reduced to the setting the tape reels and to the fixing-in of the end before the start of the operation.

The efficiency of the automatically operating devices together with the machine comprises both in reading and recording from 1000 to 20,000 lines per second (50,000 to 100,000 digits per second) depending on the width of the tape and density of the recording. The designs of the magnetic tape devices are not complicated in principle but require high precision in the manufacture and assembly. Considerable technical difficulties arise in the manufacture of the magnetic heads and of the components connected with them. The setting-up and the repairs of the devices operating with magnetic tape are very complicated in view of the extremely high precision in the adjustment of the tape-winding mechanisms.

The check of the correctness of the recording and reading is also difficult. In order to secure control precision, it is necessary to make the equipment more complicated or lower the density of the recording.

Devices for the primary recording on the magnetic tape and devices for the input of information from the magnetic tape into the machine may be similar in principle and differ only in the speed of the tape movement and the electric circuit.

The tape can be moved during the reading both in the forward and reverse directions and it can be glued into a ring for repeated

reading. A big disadvantage is the presence of the lower speed limit which during the starting, stopping and reversing produces the omission of the acceleration and braking sections passed at an insufficient speed. Therefore, the development of reliable means for quick acceleration and braking is very important.

The studies carried-out, and also the experience in the operation of computers in the USSR and abroad show that in order to raise the operational reliability of the magnetic tapes, the quality of the tapes being produced should be improved, the magnetic heads unit should be made in one piece and not assembled, a tape of not more than 35 millimeters in width should be used, and tape-winding mechanisms with a constant linear speed and a follow-up system for taking up the slack and the tightening of the tape should be used to reduce the starting, acceleration, stopping and reversing time.

**CINE-FILM.** The movie film has advantages over the magnetic tape with respect to the density and speed of recording. The availability of the well-investigated and reliable cinematographic equipment makes it possible to achieve very high speeds of the film movement. An important advantage of the film is also its high mechanical strength. The movie film is convenient for recording a large amount of the repeatedly used constant initial data or commands recorded by the photographic or perforation method.

The basic drawback of the film is the impossibility of the

immediate reading of a recording that has just been made. For this purpose, a cumbersome and long process of developing and drying is necessary.

Thus, not a single one of the three information carrier groups considered, satisfies fully the modern requirements and, therefore, it is necessary to work on the search for new, more efficient materials and on the development of more improved equipment.

INPUT AND OUTPUT DEVICES. The input devices are designed for the preparation of the initial data and of the program of the solution of a problem and feeding them into the machine. The output devices are intended for the derivation, fixation and the duplication (in case of necessity) of the results of the solution of a problem.

While the operation of the machine is fully automatic and its rate may reach 200 thousand operations per second, the operation of the input and output devices is carried out with the participation of an operator and, therefore, at limited speeds.

The initial<sup>data</sup> are assembled, as a rule, on the keyboard. Therefore, the average rate of the operation of the input devices depends on the physical capabilities of the operator.

Used in a number of cases for the input and output devices are mechanical systems the rates of the operation of which are considerably lower than that of the electronic devices.

The process of the performance of a program-controlled computer

consists of the following operations.

First of all, the initial data are prepared and the program is drawn up, i.e. the sequence of the commands, the position of the switches on the control panel, the selection of the removable units of the machine, etc. are determined. All of this is set on a coded handwritten or printed list of commands. The initial data and the program are transferred onto a carrier adapted for insertion in the machine. This operation is performed by the operator by means of a keyboard with an automatic coding of the numeric material. After this, records necessary for the solution of a given problem are assembled and then the operator loads the input and the peripheral storage devices with the initial records.

The input of the program into the machine and the solution of the problem according to this program, or the control of the process are performed automatically. The results of the solution are automatically taken out from the machine and set on the output carrier.

From the output carrier the results of the solution are transferred, if necessary, onto the final record.

A thorough check guaranteeing the correct result must be provided for every one of these operations. For the performance of each one of the operations, it is necessary to use special equipment the efficiency of which may be different at every stage.

The equipment must be economical, characterized by small dimensions, low energy capacity, convenient maintenance, ease of setting-up,

inspection and repairs and finally it must be characterized by high efficiency at different stages.

The reliability and the stability of the equipment during operation are of special importance inasmuch as in the case of the high-speed program-controlled machines the reliability must be many times higher than in any other machines. This is achieved by the development of simple designs, by providing the feasibility of automatic control and signaling of incorrect performance, and by the uniformity of different devices.

The important requirements are the possibility of utilizing the equipment used in other technical branches and also the feasibility of automatic setting of the constant indices on the carrier.

Part of the composition of the input and output devices for the automatic high-speed digital computers are no fewer than three functionally different elements: a device for the primary recording on the carrier, the reading device and the printing device. Used for the primary recording is a perforator or a device for primary recording on a magnetic tape of the start-stop type controlled from a keyboard. This device can be designed both in the form of a single unit or in the form of two units - the keyboard and the recording unit proper.

Actually, the make-up of the input and output devices is frequently considerably broader. It includes devices for the duplication of the recording, copying the material from one carrier onto another, sometimes with the simultaneous change in the recording code, and also

the control devices. Some machines are adapted for the operation with several carriers at once. Such machines have to be equipped with several devices performing identical functions. In addition, part of the machine assembly may be the continuous-discrete converters which transform a continuously changing magnitude into a sequence of numerical values, and the discrete-continuous converters which make it possible to present the results of the solution in graphic form. For the purpose of reducing the nomenclature of the devices, some of them may perform several functions at once. For example, one and the same perforator may be used both for punching of the primary data and for bringing out the results and their duplication.

The basic set of the equipment of the input and output devices necessary for a normal operation of the machine must secure the recording of the initial data and the program of the solution, duplication of the information, a check of the initial data, input of the initial data and of the program of the solution into the machine, bringing out the results onto the output carrier and the printing of the results.

In view of the great diversity of the machines with respect to the purpose, and also in view of the great diversity of the problems solved on them, it is difficult to create a single set of equipment and to develop a single system of the input and output devices, and it is doubtful if this may be recognized as being technically and economically justified.

On the basis of the native and foreign experience in the operation of the automatic high-speed digital computers, a system of input and output devices independent of the machine except for the lead-in and lead-out devices should be recommended for large general-purpose machines at the computer centers where the dimensions of a machine have not particular significance. In this case it is advisable to use punch cards and magnetic tape as carriers.

The input and output devices of such machines may consist of a keyboard device for the setting and coding of the numeric material; the card perforator for recording the numeric material; the verifier of the punch cards; device for copying the numeric material from the punch cards onto magnetic tape in the required sequence (when the amount of the initial data is large); the lead-in device with photodiode reading for feeding the initial data into the machine from the punch cards (when the amount of the initial data is small) and also for the feeding of the test programs, etc.; device for the lead-in of the initial data from a magnetic tape when the amount of information is large (peripheral storage device); perforator of the results for bringing out the final or intermediate results of the solution onto the punch cards; device for a slow reproduction from a magnetic tape, this device being designed for the combined operation with the printing device when the amount of the results of the solution brought out onto the magnetic tape with the aid of the peripheral storage device is large; the printing device which must operate at the rate of

20-30 numbers per second and the graphing device for bringing out the results of the solution from the machine in the form of a graph as a final record and also for checking the progress (process) of the solution of a problem. The printing device has to bring out the results of the solution directly from the machine if these results are not many (bringing out the control points or sums) and also to print the results of the solution which are read from the punch cards or from a magnetic tape outside the machine.

For the general-purpose machines where dimensions play the deciding role, it is possible to recommend the five-channel standard telegraph tape as the information carrier.

In special machines designed for the solution of problems of a definite scope or for the control of definite processes and object, the structure of the input and output devices and the type of the carrier depend on the type of the problems to be solved, the form of the technological process and on the program of controlling an object.

At the present time, the accumulated experience in the manufacture and operation of the input and output devices makes it possible to carry out their standardization and to create a number of unified sets of these devices for different types and classes of the machines.

1561

E N D

FOR REASONS OF SPEED AND ECONOMY  
THIS REPORT HAS BEEN REPRODUCED  
ELECTRONICALLY DIRECTLY FROM OUR  
CONTRACTOR'S TYPESCRIPT

THIS PUBLICATION WAS PREPARED UNDER CONTRACT TO THE  
UNITED STATES JOINT PUBLICATIONS RESEARCH SERVICE  
A FEDERAL GOVERNMENT ORGANIZATION ESTABLISHED  
TO SERVICE THE TRANSLATION AND RESEARCH NEEDS  
OF THE VARIOUS GOVERNMENT DEPARTMENTS