

NPS-EC-00-008

# NAVAL POSTGRADUATE SCHOOL Monterey, California



**Improvement of the Time Difference  
of Arrival (TDOA) Estimation  
of GSM Signals Using Wavelets**

by

Ralph D. Hippenstiel  
Timothy Haney  
Tri T. Ha

June 30, 2000

Approved for public release; distribution unlimited.

Prepared for: TENCAP Office, Department of the Navy

**DMIC** QUALITY IMPROVED 4

20000804 178

**NAVAL POSTGRADUATE SCHOOL  
Monterey, California**

**RADM Richard H. Wells, USNR  
Superintendent**

**R. Elster  
Provost**

This report was sponsored by TENCAP Office, Department of the Navy.  
Approved for public release; distribution is unlimited.

The report was prepared by:

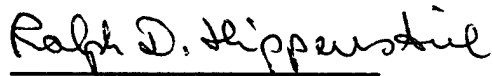

**RALPH D. HIPPENSTIEL  
Associate Professor  
Department of Electrical and  
Computer Engineering**



**TRI T. HA  
Professor  
Department of Electrical and  
Computer Engineering**

Reviewed by:



**JEFFREY B. KNORR  
Chairman  
Department of Electrical and  
Computer Engineering**

Released by:

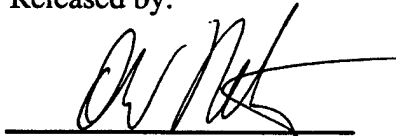

**DAVID W. NETZER  
Associate Provost and  
Dean of Research**

**REPORT DOCUMENTATION PAGE**Form Approved  
OMB No. 0704-0188

Public reporting burden for the collection of information is estimated to average 1 hour per response, including the time for reviewing instructions, searching existing data sources, gathering and maintaining the data needed, and completing and reviewing the collection of information. Send comments regarding this burden estimate or any other aspect of this collection of information, including suggestions for reducing this burden to Washington Headquarters Services, Directorate for Information Operations and Reports, 1215 Jefferson Davis Highway, Suite 1204, Arlington VA 22202-4302, and to the Office of Management and Budget, Paperwork Reduction Project (0704-0188), Washington DC 20503.

1. AGENCY USE ONLY (Leave blank)	2. REPORT DATE June 30, 2000	3. REPORT TYPE AND DATES COVERED Final Report, April 1, 1999-June 30, 2000
----------------------------------	---------------------------------	---

4. TITLE AND SUBTITLE Improvement of the Time Difference of Arrival (TDOA) Estimation of GSM Signals Using Wavelets	5. FUNDING NUMBERS N4175699WR97473
--	---------------------------------------

6. AUTHOR(S) Ralph D. Hippenstiel, Timothy Haney, and Tri T. Ha
--

7. PERFORMING ORGANIZATION NAME(S) AND ADDRESS(ES) Department of Electrical and Computer Engineering Naval Postgraduate School Monterey, CA 93943-5000	8. PERFORMING ORGANIZATION REPORT NUMBER NPS-EC-00-008
---	---

9. SPONSORING/MONITORING AGENCY NAME(S) AND ADDRESS(ES) TENCAP Office Department of the Navy, CNO/N632 2000 Navy Pentagon Washington, D.C. 20350-2000	10. SPONSORING/MONITORING AGENCY REPORT NUMBER
---	--

11. SUPPLEMENTARY NOTES The views expressed in this report are those of the author and do not reflect the official policy or position of the Department of Defense or the United States Government.
--

12a. DISTRIBUTION/AVAILABILITY STATEMENT Approved for public release; distribution is unlimited.	12b. DISTRIBUTION CODE A
---	-----------------------------

13. ABSTRACT (Maximum 200 words) The problem of localization of wireless emitters (GSM based) using time difference of arrival (TDOA) techniques is studied. The wavelet transform and denoising techniques are used to increase the accuracy of the TDOA estimate. GSM like signals are simulated using the Hewlett-Packard Advanced Designs System (HP-ADS) software. Improvement in the mean squared error (MSE) of the TDOA estimate is demonstrated. It is shown that the improvement depends on signal to noise (SNR) ratio, data length, bandwidth, and on spectral location within the frequency band of interest.
---

14. SUBJECT TERMS time difference of arrival, wavelets, denoising, GSM	15. NUMBER OF PAGES 53
	16. PRICE CODE

17. SECURITY CLASSIFICATION OF REPORT UNCLASSIFIED	18. SECURITY CLASSIFICATION OF THIS PAGE UNCLASSIFIED	19. SECURITY CLASSIFICATION OF ABSTRACT UNCLASSIFIED	20. LIMITATION OF ABSTRACT SAR
---	--	---	-----------------------------------

## TABLE OF CONTENTS

<b>I. INTRODUCTION.....</b>	<b>1</b>
<b>II. GSM AND THE TIME DIFFERENCE OF ARRIVAL.....</b>	<b>2</b>
A. REVIEW OF GSM.....	2
1. GSM Channel Structure .....	2
2. GMSK .....	4
3. Interference.....	4
4. GSM Coverage Area Layout.....	5
5. GSM Performance Enhancing Techniques .....	6
B. POSITIONING TECHNIQUES .....	7
1. Angle of Arrival (AOA).....	7
2. Time of Arrival (TOA).....	8
3. Time Difference of Arrival .....	9
<b>III. METHODS TO IMPROVE TDOA ESTIMATION .....</b>	<b>12</b>
A. FOURTH-ORDER MOMENT WAVELET DENOISING .....	13
B. MODIFIED APPROXIMATE MAXIMUM LIKELIHOOD DELAY ESTIMATION .....	14
<b>IV. SIGNAL SIMULATION AND TEST RESULTS.....</b>	<b>15</b>
A. SIGNAL GENERATION.....	15
1. Advanced Design System.....	15
2. GSM Signal Generation .....	15
B. SIMULATIONS .....	19
1. Fourth Order Moment .....	21
2. Modified Approximate Maximum Likelihood (MAML).....	24
<b>IV. SUMMARY AND CONCLUSIONS.....</b>	<b>27</b>
A. SUMMARY .....	27
B. FUTURE WORK.....	27
<b>APPENDIX A. USA TODAY ARTICLE ON CELLULAR 911     LEGISLATION.....</b>	<b>28</b>
<b>APPENDIX B. HP-ADS GSM COMMUNICATION SYSTEM     COMPONENTS .....</b>	<b>30</b>
<b>APPENDIX C. MATLAB SIMULATIONS FOR EACH DATA SET .....</b>	<b>32</b>
<b>APPENDIX D. MATLAB CODES .....</b>	<b>35</b>
<b>LIST OF REFERENCES .....</b>	<b>46</b>

**INITIAL DISTRIBUTION LIST ..... 48**  
**TABLE OF CONTENTS..... 49**

## I. INTRODUCTION

The ability to obtain localization information from a cellular phone transmission is becoming very important. Legislation requiring the development of this technology was recently introduced. This legislation followed a move by the FCC which requires, by the end of 2001, that cellular 911 calls automatically provide the caller's location, see appendix A.

There are many ways in which this technology can be beneficial to public and private enterprises. It can also provide an invaluable resource in certain military applications. The most obvious application is the localization of a friendly or unfriendly emitter.

The research, discussed in here, is a continuation and follow on to the work documented in [7,8,10,13]. It addresses the use of a GSM simulation module that permits close to real live representations of signals produced in a GSM type modulation and demodulation process. It also allows fine tuning of the algorithms discussed in [10] for better performance.

## **II. GSM AND THE TIME DIFFERENCE OF ARRIVAL**

### **A. REVIEW OF GSM**

Global System for Mobile Communications (GSM) is the European standard for digital mobile telephones. It was developed in 1990 and implemented in 1991 to replace first generation European cellular systems, which were generally incompatible with each other. It has gained worldwide acceptance as the first universal digital cellular system with modern network features extended to each mobile user, and is a strong contender for Personal Communication Service (PCS) above 1800 MHz throughout the world [2] . It also has a large market share in the Near East and Far East.

#### **1. GSM Channel Structure**

GSM uses both Time Division Multiple Access (TDMA) and Frequency Division Multiple Access (FDMA) in its operation, taking advantage of both types of modulation schemes. The GSM system uses two 25 MHz bands. It utilizes two RF bands, one RF band for the uplink (mobile station to base station) and the other RF band for the downlink (base station to mobile). FDMA divides each of these bands into 125 spectral channels, each with a bandwidth of 200 kHz. TDMA allows for 8 different time slots , with each time slot being 576.92 microseconds in length. Details of the GSM structure can be obtained from Figure 2.1.

The grouping of these 8 time slots is called a frame. This combined with the set up of FDMA provides for a total of 1000 actual speech or data channels. Currently, there

is a half-rate speech coder in the process of development that will double the number of channels to 2000 [3].

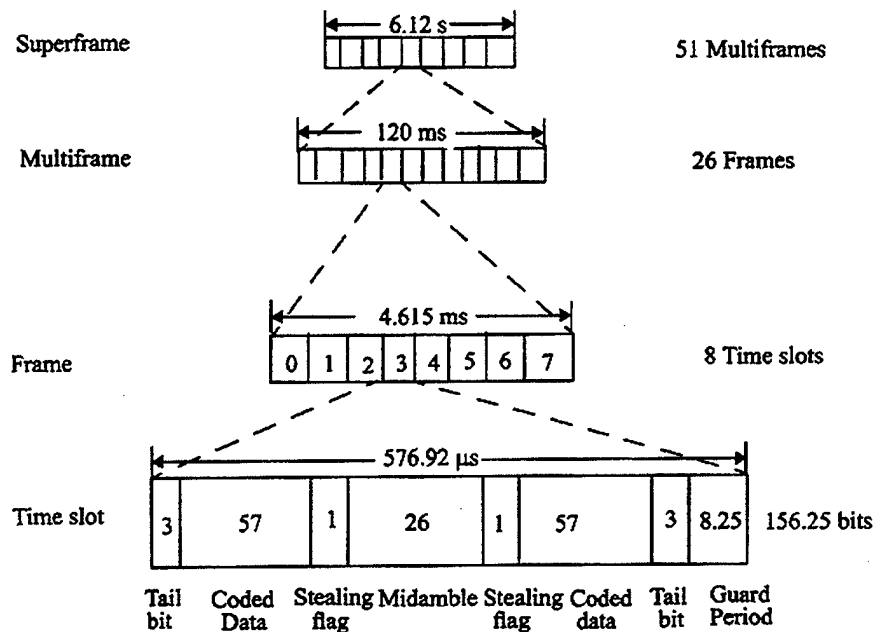

Figure 2.1: GSM Frame Structure

Some channels are dedicated as control channels or logical channels. Each logical channel has a specific purpose ranging from transmitting system parameters, to coordinating channel usage between base station and mobile. The logical channels are mapped onto dedicated time slots of particular frames. This is executed using a burst structure, the most commonly used being a normal burst. Contained in the middle of this burst is a 26-bit training sequence, chosen for its correlation properties. This received burst is correlated with a local copy of the training sequence to allow for the estimation of the impulse response of the radio channel, which aids in the demodulation of the bits in the burst.

## **2. GMSK**

GSM uses 0.3 Gaussian Minimum Shift Keying (GMSK) as its method of modulation. This facilitates the use of narrow bandwidth and coherent detection capability. This results in significantly reduced sidelobe levels of the transmitted spectrum and tends to stabilize the instantaneous frequency variations over time. The value of 0.3 represents the 3 dB-bandwidth-bit duration product (BT) or normalized pre-Gaussian bandwidth, which corresponds to a filter bandwidth of 81.25 kHz for an aggregate data rate of 270.8 Kbps. GMSK sacrifices the irreducible error rate for good spectral efficiency and constant envelope properties

All base stations transmit a GSM synchronization burst via the synchronization channel. Contained in the burst is another 64-bit training sequence. The autocorrelation function for this sequence reveals a main correlation peak with a width of 4 bits. Compared to signals used in other time-based positioning systems, this is relatively wide. The GMSK modulation technique is responsible for this increased width. This is significant from a time-based positioning standpoint because it reduces the timing resolution and hence the maximum achievable position accuracy.

## **3. Interference**

In the mobile radio path, the GSM signal will experience some inter symbol ISI. The mobile radio channel is generally hostile in nature and can affect the signal to such an extent that the system performance is seriously degraded [4]. Inherent in any communication system is the phenomenon known as multipath. This refers to the situation where a signal propagating from a transmitter to a receiver can travel via several

different paths including line of sight and one or more reflected paths. The reflected paths cause delay, attenuation in the amplitude, and phase shifts relative to the direct path. In some environments, multipath components may be delayed by up to 30 microseconds. These delayed components cause ISI in the received signal [5]. The degree of distortion depends on the relative amplitude, delay, and phase of the received signals.

The conventional GSM receiver contains a signal demodulator which equalizes the received signal to improve system performance in the presence of multipath by combining the information received from the different arrivals. The equalizer does not reject multipath signals, but combines them. However, for positioning reasons, the receiver needs to be able to determine the first arrival corresponding to the line of sight, and thus requires a multipath rejection algorithm [1].

#### **4. GSM Coverage Area Layout**

The area that a GSM network covers is divided into a number of cells, each served by its own base station (BS), also known as a base transceiver station. The number of cells served by each BS, called a cluster, is determined by the amount of system capacity (total available channels) required for a particular area. A larger cluster size is an indication of a larger capacity system. One tradeoff associated with the larger capacity system is that a more complex system is required to control the increased demand for frequency reuse. Also, more cells per cluster translates into smaller individual cell size and thus, more co-channel interference for which to account, as well as a greater frequency of handoffs between cells. The typical cluster size is 4, 7, or 12.

## **5. GSM Performance Enhancing Techniques**

In addition to increasing the number of cells per cluster, GSM uses a number of other methods to increase capacity. These are important because they provide favorable implications for positioning. One such technique is the use of sectored cells. Sectoring effectively breaks the cell down into groups of frequencies (channels) that are only used within a particular region. Not only does this technique offer additional information for use by a positioning system, but it also has the effect of reducing co-channel interference. This reduced co-channel interference is due to the fact that a given cell receives interference and transmits with only a fraction of the available co-channel cells.

Another performance enhancing technique employed by GSM is slow frequency hopping; so termed because the hopping rate is low compared with the symbol or bit rate. The mobile radio channel is a frequency-selective fading channel, which means the propagation conditions are different for each individual radio frequency. Slow-frequency hopping is used instead of fast-frequency hopping because, in order to perform well, a frequency synthesizer must be able to change its frequency and settle quietly on a new one within a fraction of one time slot (576.92 microseconds). Frequency hopping provides frequency diversity to overcome Rayleigh fading due to the multipath propagation environment. Frequency hopping also provides interference diversity. A receiver set to a channel with strong interference will suffer excessive errors over long strings of bursts. Frequency hopping prevents the receiver from spending successive bursts on the same high-interference channel. Frequency hopping also contributes to a reduction in the minimum signal-to-noise ratio (SNR) required.

## **B. POSITIONING TECHNIQUES**

It is important to remember that in order to comply with the FCC ruling, any positioning solution must work with existing phones. For this reason, most cellular geolocation proposals are multilateral, where the estimate of the mobile's position is formed by a network rather than by the mobile itself. There are three ways that position localization information can be determined using the signaling aspects inherent in the GSM specification. One is through is the Angle of Arrival (AOA) method, which uses sector information. Second, is through the use of propagation time using timing advances (TA). Third, is the Time Difference of Arrival (TDOA) method, which offers several advantages over the previous methods. In addition to providing some immunity against timing errors when the source of major reflections is near the mobile, the TDOA method is less expensive to put in place than the AOA method. Also, the AOA and TOA methods are hampered by requirements for line of sight (LOS) signal components, whereas the TDOA method may work accurately without a LOS component. Each method will be briefly described before taking an in-depth look at the TDOA.

### **1. Angle of Arrival (AOA)**

If two or more BS platforms are used, the location of the desired mobile in two dimensions can be determined from the intersection of two or more lines of bearing (LOB), with each LOB being formed by a radial from a base station to the mobile. The LOB's from the mobile to two adjacent platforms form what is called a measured angle,

φ. After two measured angles are calculated, trigonometry or analytic geometry may then be used to deduce the location of the MS.

Another variation of the AOA method relies upon the sectoring of cells for all of its positioning information. Cell sectoring involves the use of highly directive antennas to effectively divide the cell into multiple sections. The angle of arrival can be determined at the base station by electronically steering the main lobe of an adaptive phased array antenna in the direction of the arriving mobile signal. In this case, a single platform may be sufficient for AOA positioning, although typically, two closely spaced antenna arrays are used to dither about the exact direction of the peak incoming energy to provide a higher resolution measurement [9].

AOA measurements might provide an excellent solution for wireless transmitter localization were it not for the fact that this method requires signals coming from the mobile to the base station be from the line of sight (LOS) direction only. This is seldom the case in cellular systems given that the operating environment is often heavily cluttered with rough terrain, tall buildings and other obstructions.

## **2. Time of Arrival (TOA)**

Since GSM is a TDMA system, its successful operation depends on the ability of all signals to arrive at the BS at the appropriate time. And since the signals arriving at the BS's originate from different distances, the time at which the signals are sent must be varied. This is accomplished by having each BS send a timing advance (TA) to each MS connected to it. The TA is the amount by which the mobile station (MS) must advance the timing of its transmission to ensure that it arrives in the correct time slot. Obviously,

the TA is a measure of the propagation time, which is proportional to the distance from the BS to the MS. Hence, the location of the MS can be constrained to a circular locus centered on the BS. If the MS could somehow be forced to hand over to two more BS's, it would be possible to implement a positioning scheme based on the intersection of the three circles.

One problem with the TOA technique is that artificially forced handoffs can be made to less optimal BS's. This degrades call quality as well as reduces system capacity. Also, this method requires that all transmitters and receivers in the system have precisely synchronized clocks, since just 1 microsecond of timing error could result in a 300 meter position location error [9]. The use of the TA, which is in essence a timestamp, is a burden that most would rather not have to deal with. Furthermore, the employment of it presents another problem. Under GSM specifications, the TA is reported in units of a bit period, which equates to a locus accuracy of 554 meters. Even this considerable amount of area will increase when multipath degradations and dilution of precision (the amount by which errors are degraded by geometry) are taken into account.

### **3. Time Difference of Arrival**

The idea behind TDOA is to determine the relative position of the mobile transmitter by examining the difference in time at which the signal arrives at multiple base station receivers. Each TDOA measurement determines that the transmitter must lie on a hyperboloid with a constant range difference between the two receivers. The equation for this range difference is given by

$$R_{i,j} = \sqrt{(X_i - x)^2 + (Y_i - y)^2 + (Z_i - z)^2} - \sqrt{(X_j - x)^2 + (Y_j - y)^2 + (Z_j - z)^2} \quad (2.1)$$

where the coordinates  $(X_i, Y_i, Z_i)$  and  $(X_j, Y_j, Z_j)$  represent the position-fixed receivers  $i$  and  $j$ , and  $x, y$ , and  $z$  represent the unknown coordinate of the target transmitter [9].

The location of the mobile can be estimated in two dimensions from the intersection of two or more hyperboloids generated using TDOA measurements from three or more base stations. This can be extended to three dimensions if four or more TDOA measurements are used. The TDOA requires that all fixed transmitters and receivers in the system have precisely synchronized clocks. This, corresponds to the timing standards already in place at cellular BS sites. Unlike the TOA measurements, TDOA measurements do not require a timestamp of the transmitted signal.

The process of localizing the position of a cellular transmission occurs in two stages. First, an accurate estimate of the TDOA measured values must be determined from the noisy signals that are received. This involves some type of denoising technique, the most popular being wavelet denoising, which is discussed in detail in [10]. This involves taking the wavelet transform of the received signal, thresholding the wavelet coefficients, and performing the inverse wavelet transform using the modified coefficients. Second, a location of position estimate is determined from the TDOA calculations. Both phases are complex and subject to minor inconsistencies that can propagate into large errors. Accurate and efficient algorithms are required for both stages of processing. To evaluate the hyperbolic range equation (2.1), one must first estimate the range differences  $R_{i,j}$ , or equivalently, the TDOA  $t_i - t_j$ . The most widely accepted method for obtaining these values is the generalized cross-correlation method. If the

transmitted signal is  $s(t)$ , then the signal that arrives at one receiver,  $x(t)$ , will be delayed and corrupted by noise and is given by

$$x(t) = \alpha s(t - d_i) + n_i(t), \quad 0 < \alpha < 1 \quad (3.1)$$

where  $d_i$  is the delay time from the mobile to receiver one,  $n_i(t)$  is noise, and  $\alpha$  is the gain. Similarly, the signal that arrives at another receiver,  $y(t)$ , is given by

$$y(t) = \beta s(t - d_j) + n_j(t), \quad 0 < \beta < 1 \quad (3.2)$$

where  $d_j$  is the delay time from the mobile to receiver two,  $n_j(t)$  is the noise, and  $\beta$  is the gain. The cross-correlation function between the two received signals is derived by integrating the lag product of the two signals for a sufficiently long time period,  $T$ . This function is given by

$$\hat{R}_{x,y}(\tau) = \frac{1}{T} \int_0^T x(t)y(t-\tau)dt \quad [9]. \quad (3.3)$$

This approach requires that the receiving base stations share a precise time reference and reference signals, but does not impose requirements on the signal transmitted by the mobile. Note, that we can improve the SNR of the TDOA estimation by increasing the integration interval,  $T$ . The maximum likelihood estimate of the TDOA is obtained from the computed cross-correlation function. This estimate corresponds to the value of  $\tau$  that maximizes the cross-correlation function, Eq. (3.3).

### III. METHODS TO IMPROVE TDOA ESTIMATION

Any effort to improve the TDOA estimation must focus primarily on reducing the effective noise at the receivers. Earlier research presented seven different denoising schemes designed toward this end: 1) wavelet denoising based on Donoho's method, 2) wavelet denoising using the Wo-So-Ching threshold, 3) wavelet denoising using hyperbolic shrinkage, 4) wavelet denoising using median filtering, 5) denoising based on the fourth order moment, 6) modified approximate maximum-likelihood delay estimation, and 7) a time-varying approximate maximum-likelihood technique. The results of simulation of each of these methods is shown in Figure 3.1 [10].

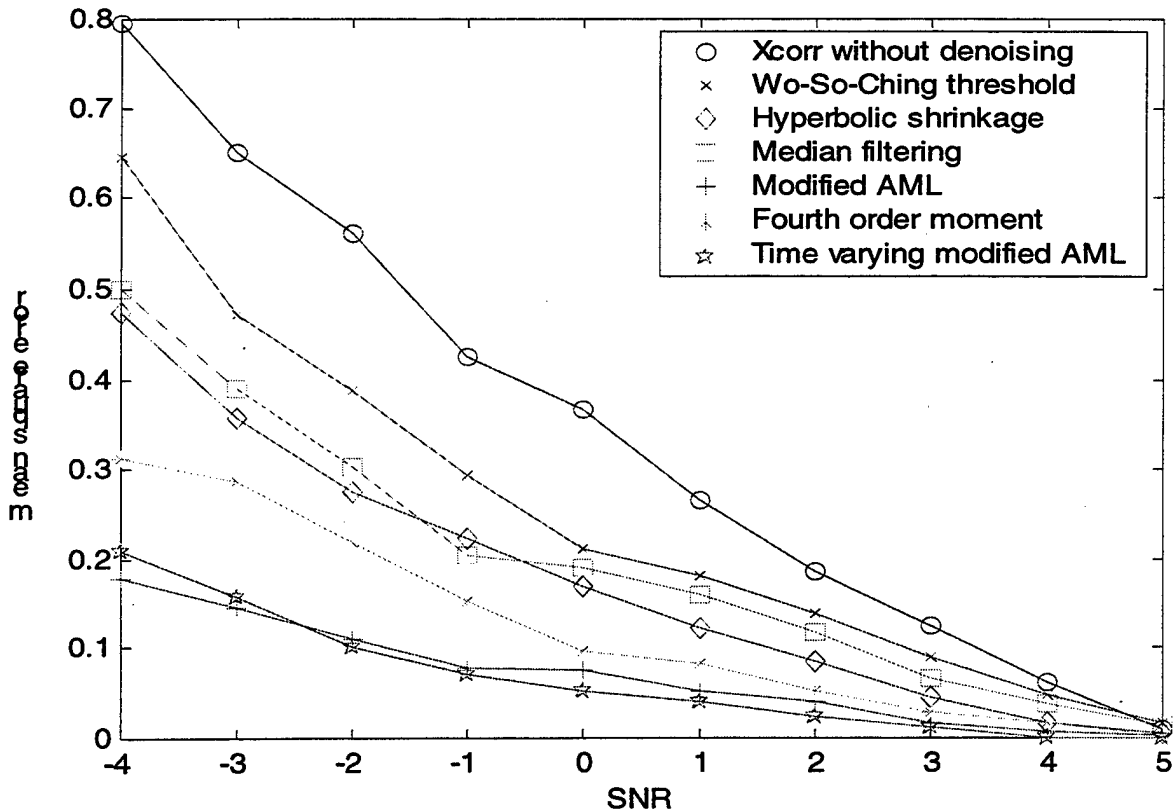

Figure 3.1: Comparison of Denoising Methods for the GSM Signal

It was shown that method 1 failed at low SNR's. Experimental results from [10] showed that method 2, while an improvement over method 1, loses its advantage with increasing carrier frequency. Additional improvements are made using methods 3 and 4, but as can be seen in Figure 3.1, the best results (lowest mean-square error) are obtained using methods 5 through 7. We will take a closer look at method 5 and 6.

#### A. FOURTH-ORDER MOMENT WAVELET DENOISING

Inevitably, any transmitted signal will acquire some type of additive noise before reaching the receiver. A Gaussian signal being completely characterized by its second order statistics and the odd order moments being equal to zero for a symmetric probability density function, the separation of the signal and the noise requires at least the use of the fourth-order moments [11].

To define the fourth-order moment, we first model the received signal as:

$$z(n) = x(n) + l(n) \quad (3.1)$$

where  $x(n)$  is a complex zero-mean, non-Gaussian, fourth order stationary signal and  $l(n)$  is the noise, which is a complex zero mean-Gaussian signal independent of  $x(n)$ .

The fourth-order moment is then [11]:

$$M_{4z}(j-i, k-i, l-i) \equiv E(z_i, z_j, z_k^*, z_l^*) \quad (3.2)$$

It was shown that the fourth order moment of a detail function which contains the signal should be greater than  $3\sigma_{nd_i}^4$ , where  $\sigma_{nd_i}^4$  is the noise power at subband  $d_i$  [10].

By using this property, the wavelet coefficients that represent noise can be eliminated while those having a signal dependency are retained. After modifying the

detail functions, the denoised signal is obtained by performing an inverse wavelet transform using the modified coefficients.

## **B. MODIFIED APPROXIMATE MAXIMUM LIKELIHOOD DELAY ESTIMATION**

Critical to the task of source localization is the time delay estimation between signals received at two spatially separated sensors in the presence of noise. If we let  $s(n)$  represent the source signal,  $n_1(n)$  and  $n_2(n)$  represent the additive noises at the respective sensors, and  $D$  is the difference in arrival times at the two receivers, then the receiver outputs,  $r_1(n)$  and  $r_2(n)$ , are given by

$$r_1(n) = \alpha_1 s(n) + n_1(n), \quad n = 0, 1, \dots, T-1 \quad (3.3)$$

$$r_2(n) = \alpha_2 s(n - D) + n_2(n), \quad 0 < \alpha_1, \alpha_2 < 1 \quad (3.4)$$

where  $T$  is the number of samples collected at each channel.

In the modified approximate maximum likelihood (MAML) delay estimation, after wavelet decomposition and prior to cross-correlation, both the channel outputs are optimally weighted at different frequency bands (i.e., scales). This weighting is done to reduce the noise influence. The scaled subband components are combined using inverse wavelet transform to construct the MAML prefiltered signal. The orthogonal wavelet transform is attractive because in addition to being computationally efficient, it is less sensitive to performance degradation in the estimation of  $D$  [12]. The final MAML delay estimate is calculated from the location of the peak of the cross-correlation function of the two denoised signals.

## IV. SIGNAL SIMULATION AND TEST RESULTS

### A. SIGNAL GENERATION

All test signals used in this project were generated using the Hewlett-Packard Advanced Design System (HP-ADS). This provided an excellent method of obtaining signals that are essentially the same as would be encountered in an actual cellular communication receiver.

#### 1. Advanced Design System

The HP-ADS program is an invaluable tool for the engineers representing many different design aspects such as communications, digital signal processing, electronic circuits, mechanical circuits, and many others. The communications package allows the user to custom design any type of communications system, run simulations of the design, and extract data collected from the simulation. Figure 4.1 shows the system used for the signal simulation. A more detailed view of each of the major components of this system can be found in Appendix [B].

#### 2. GSM Signal Generation

One parameter that must be specified for the GSM signal generation is the sample time. The specifications of the GSM signal were given in Chapter II. The HP-ADS program specifies a symbol period of 3.7037 microseconds. The filter bandwidth is 1.2 MHz. This allows us to sample at a minimum frequency of 2.4 MHz without violating the Nyquist criterion. For test purposes, we use three different sampling frequencies. As

shown in Table 4.1, these are: 10.8 MHz, which corresponds to a sample time of 92.592 microseconds; 5.4 MHz, which corresponds to a sample time of 185.185 microseconds; and 2.7 MHz, which corresponds to a sample time of 370.370 microseconds.

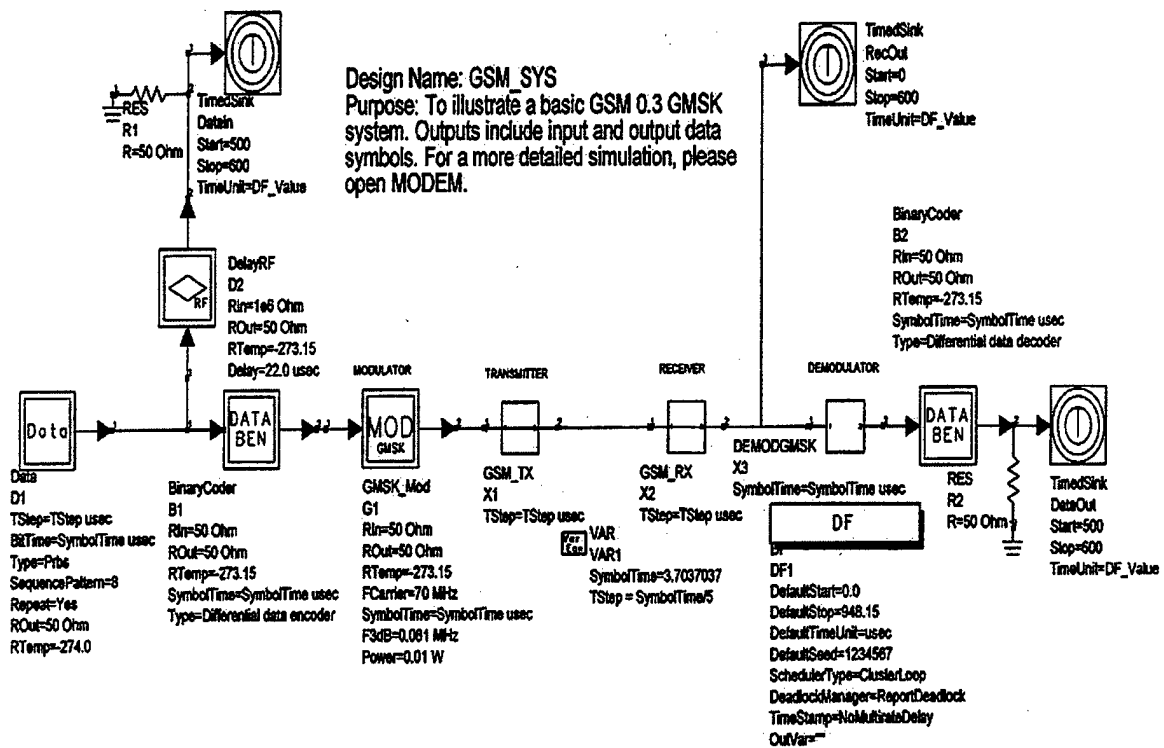

Figure 4.1: HP-ADS GSM Communications System

Samples/Symbol	Sample Time (microseconds)	Sampling Frequency (Megahertz)	Symbols/600 Samples
40	92.592	10.8	15
20	185.185	5.4	30
10	370.37	2.7	60

Table 4.1: GSM Signal Parameter Combinations

Realizations of the I and Q channel outputs of the GSM signals are shown in Figure 4.2. For test purposes, we use a constant number of samples (600) for all simulations. One fact that is immediately evident from Figure 4.2 is that as the sampling interval increases, so does the variation in the GSM signals. We also realize a better correlation characteristic with increasing sample time as shown in Figure 4.3. Better correlation is demonstrated by a sharper main lobe with lower sidelobes. Figure 4.3 (d) shows the correlation of the Matlab generated GSM signal presented by Aktas [10].

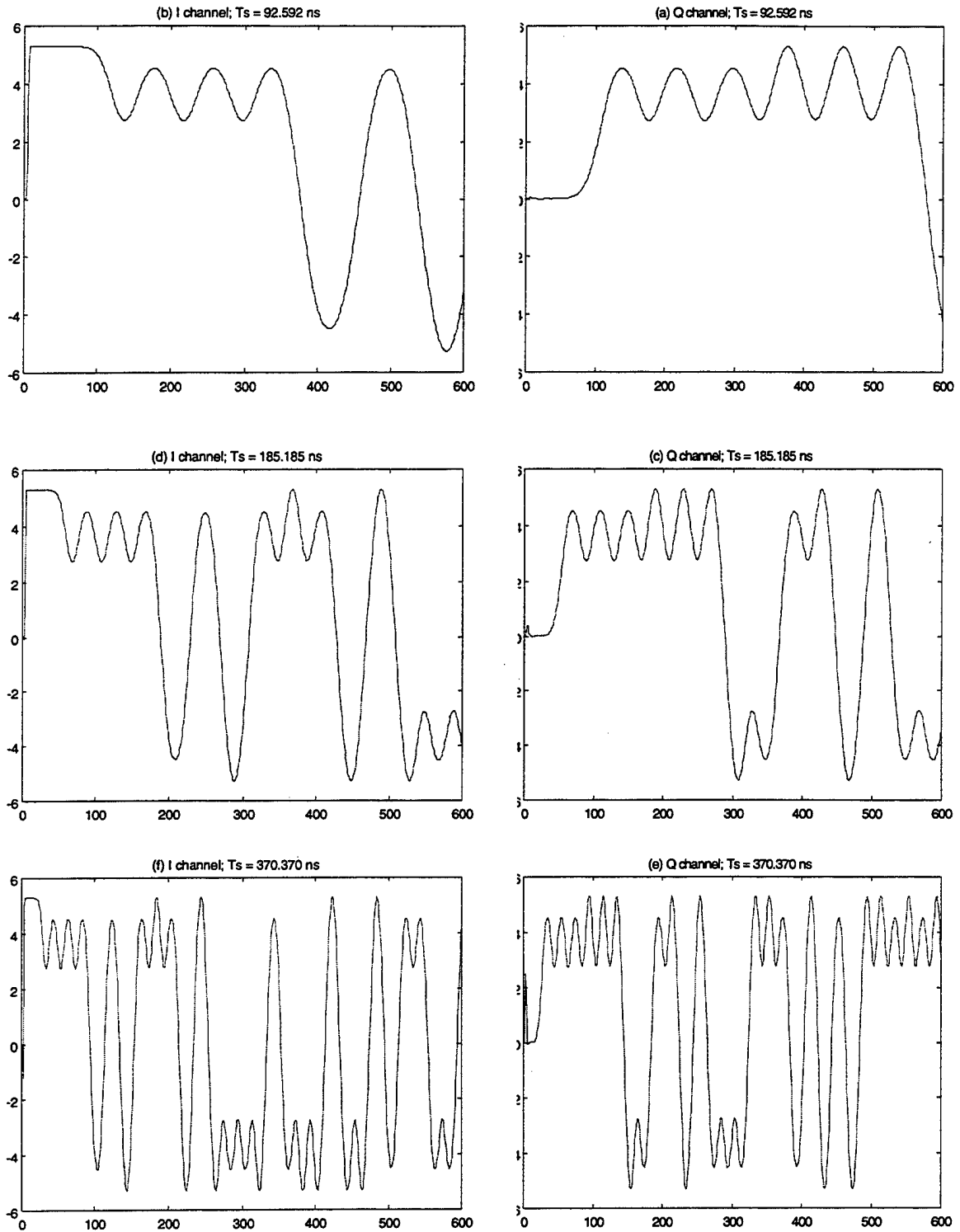

Figure 4.2: HP-ADS Produced GSM Signals

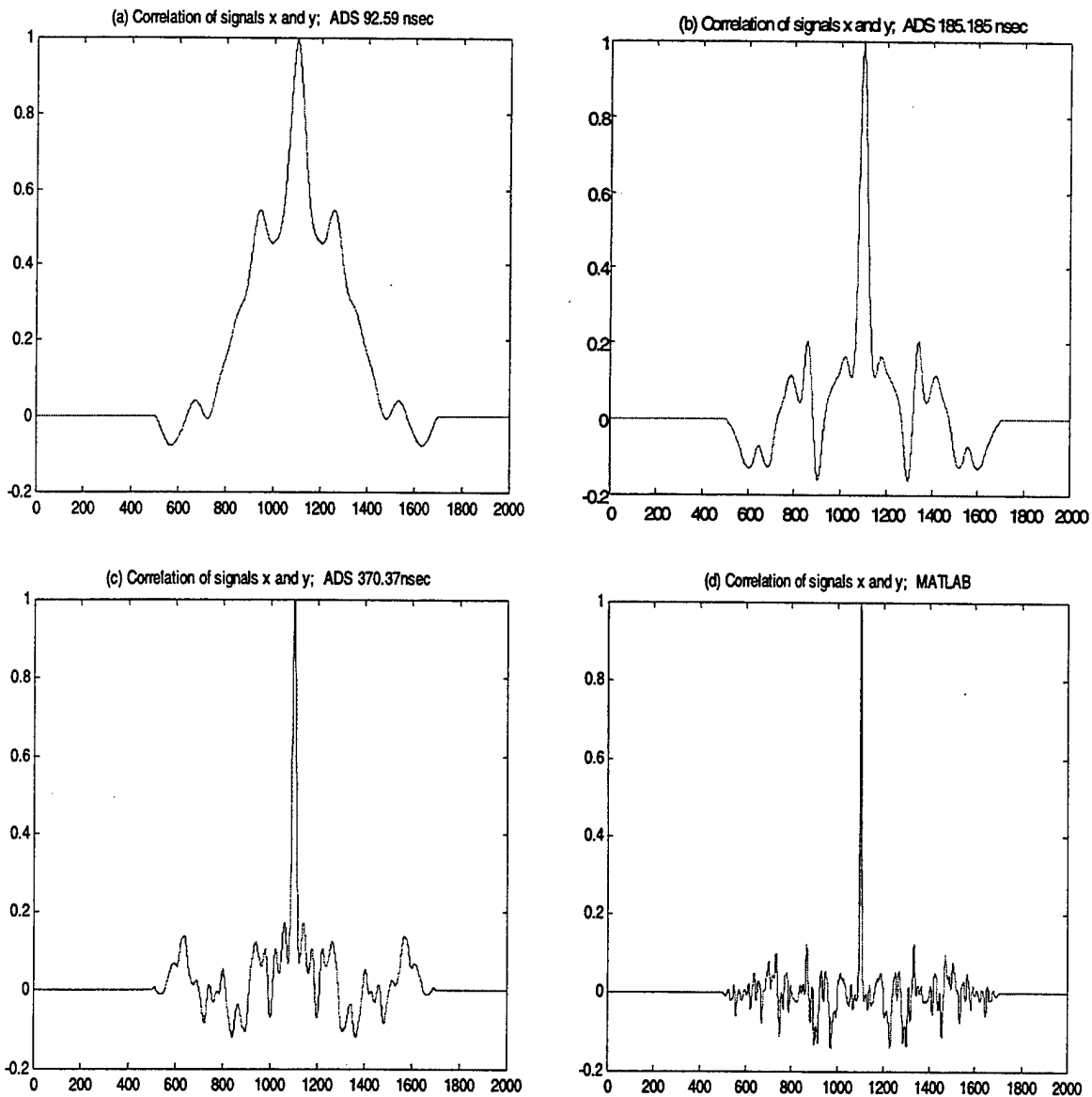

Figure 4.3: Auto-Correlation Results of Test Signals

## B. SIMULATIONS

In Chapter III, we discussed two methods to improve the TDOA estimate. In this section, we will use these methods to test our HP-ADS generated signals and see if we are able to extract useful TDOA data. Bear in mind that our criterion for improvement in

TDOA estimation is a lower mean-squared error. Each method was tried using four different realizations for each of the three sampling times, for a total of twelve different realizations per method used. However, we will only present one set from each sample time here, as each set follows a similar trend. The remainder of the plots can be found in Appendix [C]. To simplify explanation, we shall label the data sets as follows:

- a) HP-ADS generated signal with a sample interval of 92.59 nsec.
- b) HP-ADS generated signal with a sample interval of 185.185 nsec.
- c) HP-ADS generated signal with a sample interval of 370.370 nsec.
- d) Matlab generated signal.

We will use the Matlab generated signal as our benchmark for comparison. For each method we will plot the mean-squared error against SNR's in the range of -6 dB to 20 dB. For clarity in the following discussion, we define the terms average error and percentage improvement. Average error is calculated by adding all non-zero error values for a particular realization, and dividing that sum by the total number of the non-zero elements in that realization. Percentage improvement, as shown in the equation below, is calculated by subtracting the improved value from the original value and dividing the difference by the original value then multiplying by 100:

$$\frac{\textit{original value} - \textit{improved value}}{\textit{original value}} \times 100\% = \textit{percent improvement}$$

## 1. Fourth Order Moment

The results using this method are shown in Figure 4.4. There are two obvious trends that are noticed in this figure. We can easily see that the mean-squared error

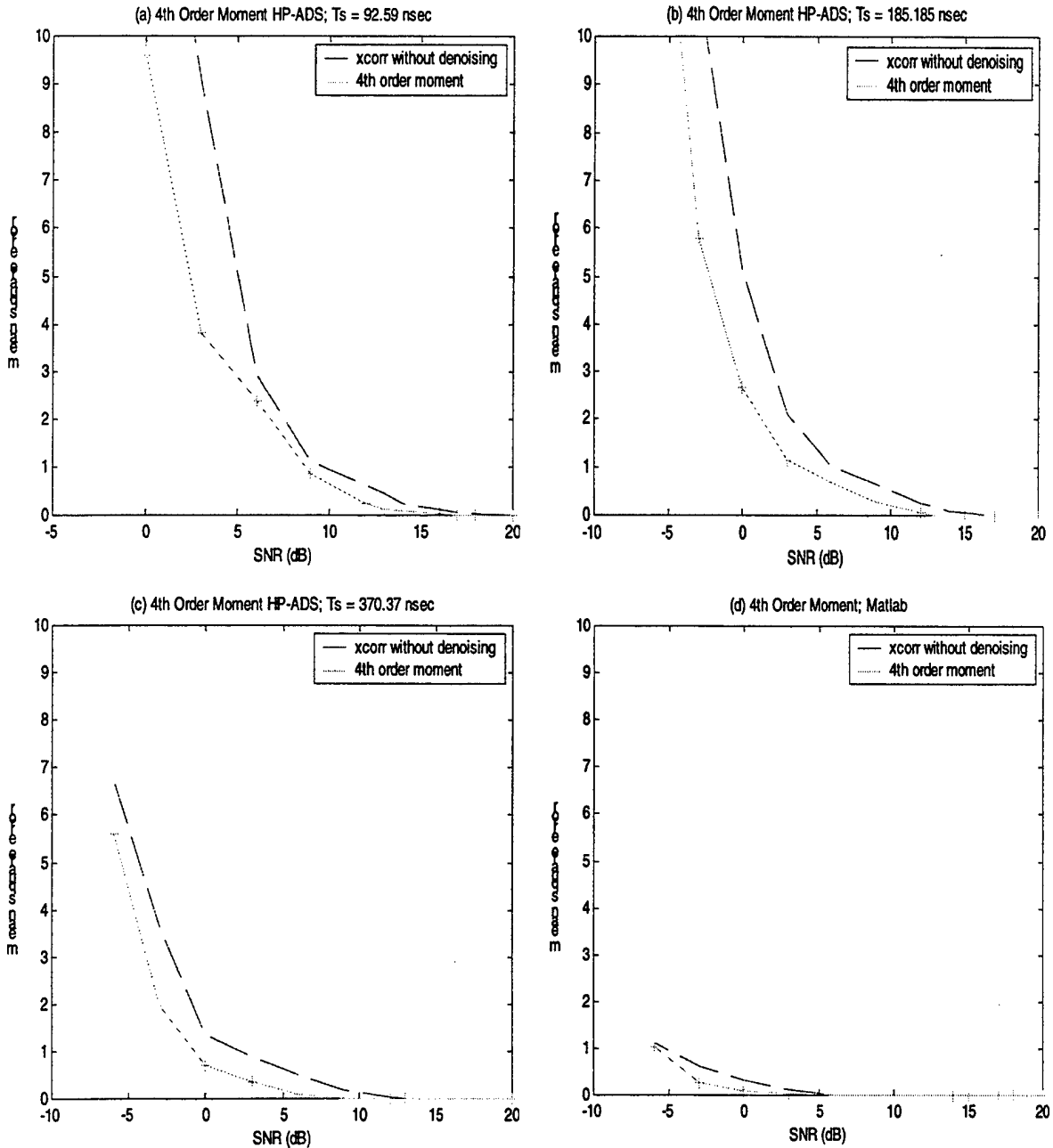

Figure 4.4: Results of Varying Sampling Interval for Fourth-Order Moment Technique

improves (decreases) as the sampling interval increases. This observation is presented numerically in Table 4.2. From this table, we can clearly see a decrease in error values as we move from left to right across each row.

In the Matlab plot (Figure 4.4 (d)), or our benchmark plot, notice that the mean-squared error is zero at 6 dB and higher SNR for the Fourth-Order Moment denoised curve. Also notice that, as expected, the denoised curve is lower than the non-denoised

S	Mean Squared Error							
	case (a)		case (b)		case (c)		case (d)	
	Sample Time = 92.59 nsec		Sample Time = 185.185 nsec		Sample Time = 370.370 nsec		Matlab Generated	
R	No Denoising	Fourth-Order Denoising	No Denoising	Fourth-Order Denoising	No Denoising	Fourth-Order Denoising	No Denoising	Fourth-Order Denoising
-3	38.35	26.30	11.04	5.80	3.65	1.96	0.63	0.25
0	16.72	9.60	5.15	2.66	1.34	0.70	0.31	0.08
3	9.03	3.82	2.11	1.15	0.88	0.35	0.11	0.02
6	2.89	2.38	1.02	0.67	0.49	0.10	0	0
9	1.11	0.86	0.65	0.27	0.19	0.01	0	0
12	0.63	0.24	0.240	0.05	0.02	0	0	0
15	0.17	0.05	0.060	0	0	0	0	0
18	0.03	0.01	0	0	0	0	0	0
20	0	0	0	0	0	0	0	0

Table 4.2: Mean-Squared Error Values at Varying SNR for the Fourth Order Moment

curve at all points. This shows that the denoising is effective in producing an improved TDOA estimate.

Using the HP-ADS data with a sampling interval of 92.59 nsec, case(a), the mean-square error at  $-3$  dB SNR is 26.3 when fourth-order denoising is employed. This is a 31.4% improvement from the non-denoised curve. The average percentage improvement over all SNR's between  $-3$  and 20 is 45.6%.

Using HP-ADS data with a sampling interval of 185.185 nsec, we notice an average 52.2% increase with fourth-order moment denoising. The mean-squared error is 5.68 at  $-3$  dB, which is a 78.4% improvement over the  $-3$  dB value of case (a).

Using HP-ADS data with a sampling interval of 370.37 nsec, case (c), we obtain even better results. The mean-squared error at  $-3$  dB is now 1.96, which is a 65.5% improvement over case (b). The average improvement realized by using fourth-order moment denoising instead of the non-denoised method in this case is 69.0%. We now see a definite trend that as our sampling interval increases, denoising increasingly improves the mean squared error values.

In the benchmark case (d), there is a maximum mean-squared error of 0.25 at  $-3$  dB using fourth-order denoising. The average percentage improvement of fourth-order moment denoising over non-denoising is 72.5%. We also notice that the mean-squared error is zero for all SNR above 6 dB.

The improvements we have discussed in this section can be related to the correlation function plots presented in Section 4.A. There, we saw that the correlation function plot improved with increasing sample time. Here, we state that improved

correlation of the signal components reduces the probability of error in the TDOA calculations. Thus, we achieve lower mean square error values with increasing degree of correlation of signal components.

## 2. Modified Approximate Maximum Likelihood (MAML)

The results using this method are shown in Figure 4.5. We notice a similar trend as in the fourth order moment method. We end up with lower mean squared error values

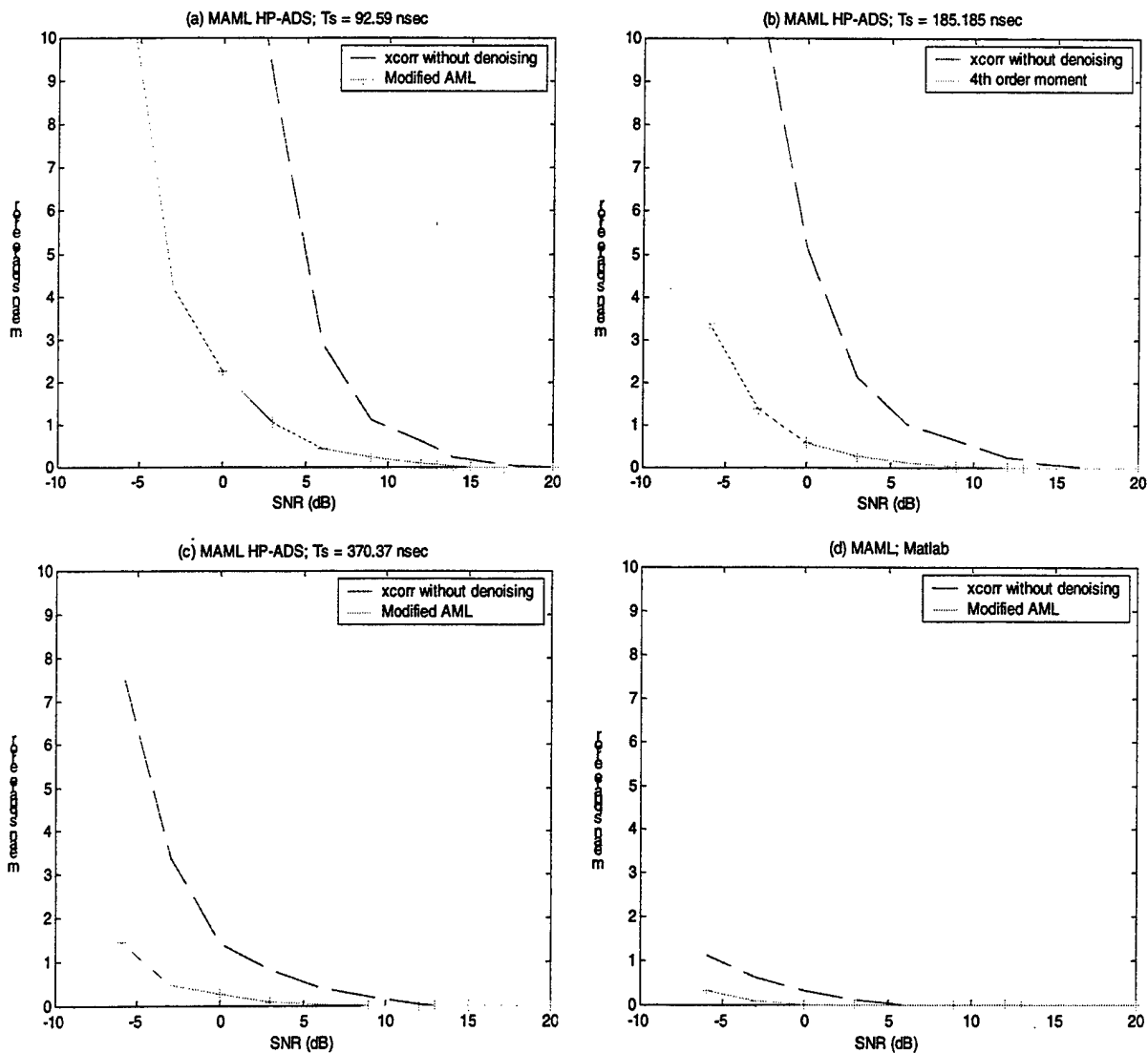

Figure 4.5: Results of Varying Sample Times for MAML Technique

as the sampling interval increases. We also notice that these mean squared error values are lower than those obtained in the fourth order moment method, as evidenced in Table 4.3.

In case (a), there is an average improvement in mean squared error of 89.6% by employing MAML denoising. Recall, from Section 4.B.1, the fourth order moment

S N R	Mean Squared Error							
	case (a) Sample Time = 92.59 nsec		case (b) Sample Time = 185.185 nsec		case (c) Sample Time = 370.370 nsec		case (d) Matlab Generated	
	No Denoising	MAML Denoising	No Denoising	MAML Denoising	No Denoising	MAML Denoising	No Denoising	MAML Denoising
-3	38.35	4.18	11.04	1.37	3.65	0.47	0.63	0.09
0	16.72	2.27	5.15	0.60	1.34	0.25	0.31	0.01
3	9.03	1.05	2.11	0.27	0.88	0.08	0.11	0
6	2.89	0.43	1.02	0.13	0.49	0.02	0	0
9	1.11	0.22	0.65	0.02	0.19	0	0	0
12	0.63	0.10	0.240	0	0.02	0	0	0
15	0.17	0	0.060	0	0	0	0	0
18	0.03	0	0	0	0	0	0	0
20	0	0	0	0	0	0	0	0

Table 4.2: Mean-Squared Error Values at Varying SNR for MAML Method

denoising method produced only an average 45.6% improvement for case (a). Thus, we have proved that the MAML denoising method is, in fact, superior to the fourth order moment. In cases (b) and (c), there is an average improvement of 89.5% and 88.8% respectively. Thus, we have shown that using the HP-ADS program, we can simulate GSM signals and obtain the necessary TDOA estimation. Application of the fourth order moment and modified Approximate Maximum Likelihood methods reduce the error in the TDOA estimation, allowing improved localization. In the current implementation the MAML method outperforms the fourth order moment method. Matlab code can be found in appendix D.

## IV. SUMMARY AND CONCLUSIONS

### A. SUMMARY

The objectives of this work are to simulate GSM signals and to evaluate the mean squared-error for TDOA estimation. The Hewlett-Packard Advanced Design System is a very powerful communications development tool and proved invaluable toward our objective of GSM signal generation. We were able to manipulate this system to provide signals with desired characteristics which would later be used in the Matlab environment to determine the effectiveness of two different denoising methods. The denoising methods were presented in earlier research. These are the fourth-order moment and modified approximate maximum-likelihood methods. We used three signal sets generated by the HP-ADS program to test the performance of each of these methods. The results of these tests agreed with the earlier research. It showed that the current implementation of the MAML method is the best choice.

### B. FUTURE WORK

Follow on work should extend the algorithms to time-varying scenarios. An extension to determine the performance in a fading environment should also be undertaken. In addition, the situation when a weak signal is present in one channel and a stronger signal in the other channel, should be examined. One should also revisit the denoising techniques to develop improved versions.

## APPENDIX A. USA TODAY ARTICLE ON CELLULAR 911 LEGISLATION

---

### **USA today** Washington

---

10/26/99 - Updated 05:39 PM ET

#### **Clinton signs nationwide 911 law**

WASHINGTON (AP) - President Clinton signed legislation Tuesday making 911 the official emergency number nationwide - for both regular and cellular phones.

The measure also calls for development of technology that can track mobile callers.

People with wireless phones now will be able to speed responses to highway accidents, crimes and natural disasters," Clinton said.

"Getting rapid care to someone who is suffering from a heart attack or is involved in a car crash can mean the difference between life and death."

While 911 is widely used as the emergency number for traditional phones, there are 20 different codes for wireless callers across the country. The changes are aimed at cutting response times for the crews who answer 98,000 emergency calls daily from cellular phone callers.

"In my home state," said Sen. Conrad Burns, R-Mont., "three quarters of the deaths in rural areas are because the first responders couldn't get there in time."

Health care professionals joined Burns at a Capitol Hill news conference to applaud the new law.

"We have great emergency room personnel. We can do a lot for accident victims if we can find them and get them there," said Barbara Foley of the Emergency Nurses Association. "That's what this legislation helps us do."

Another provision of the act directed the Federal Communications Commission to help states develop emergency systems, including technology that can automatically locate cellular callers who have dialed 911 or been involved in an accident.

The FCC in September moved forward with plans to require that cellular 911 calls automatically provide a caller's location. Regulators want manufacturers to begin providing locator technology within two years.

Privacy advocates have raised concerns about potential abuse of the technology, which would take advantage of the Global Positioning System developed by the military.

The law signed Tuesday called on regulators to establish "appropriate privacy protection for call location information," including systems that provide automatic notification when a vehicle is involved in an accident.

It said that calls could only be tracked in nonemergency situations if the subscriber had provided written approval. "The customer must grant such authority expressly in advance of such use, disclosure or access," according to Senate documents detailing provisions of the legislation.

An estimated 700 small and rural counties have no coordinated emergency service to call - even with traditional phones. The bill would encourage private 911 providers to move into those areas by granting the same liability protections to wireless operations that now are offered to wireline emergency service systems.

Separately, the FCC took action earlier this year to increase the number of cellular calls to 911 that are successfully completed. The commission required that new analog cellular phones - not existing phones - be made with software that routes 911 calls to another carrier when a customer's own service cannot complete the call.

Calls sometimes aren't completed because a caller is in an area where his or her carrier does not have an antenna, because networks are overloaded or because buildings or geography block signals.

Digital phones, of which 18.8 million now are in use, were not covered by the new FCC rules adopted in May because such phones are more complex than their analog counterparts and there is no easy fix for the problem.

- 
- [Go to Washington news](#)
  - [Go to News front page](#)



USA TODAY  
**MARKETPLACE**  
Shop online with our Premier vendors

[Front page](#), [News](#), [Sports](#), [Money](#), [Life](#), [Weather](#), [Marketplace](#)

© Copyright 1999 USA TODAY, a division of Gannett Co. Inc.

# APPENDIX B. HP-ADS GSM COMMUNICATION SYSTEM COMPONENTS

## MODULATOR

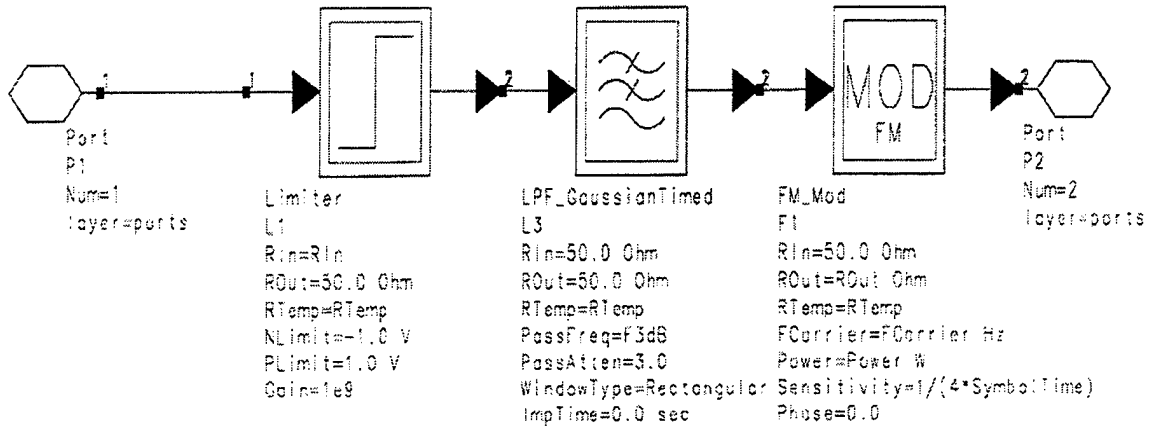

## TRANSMITTER

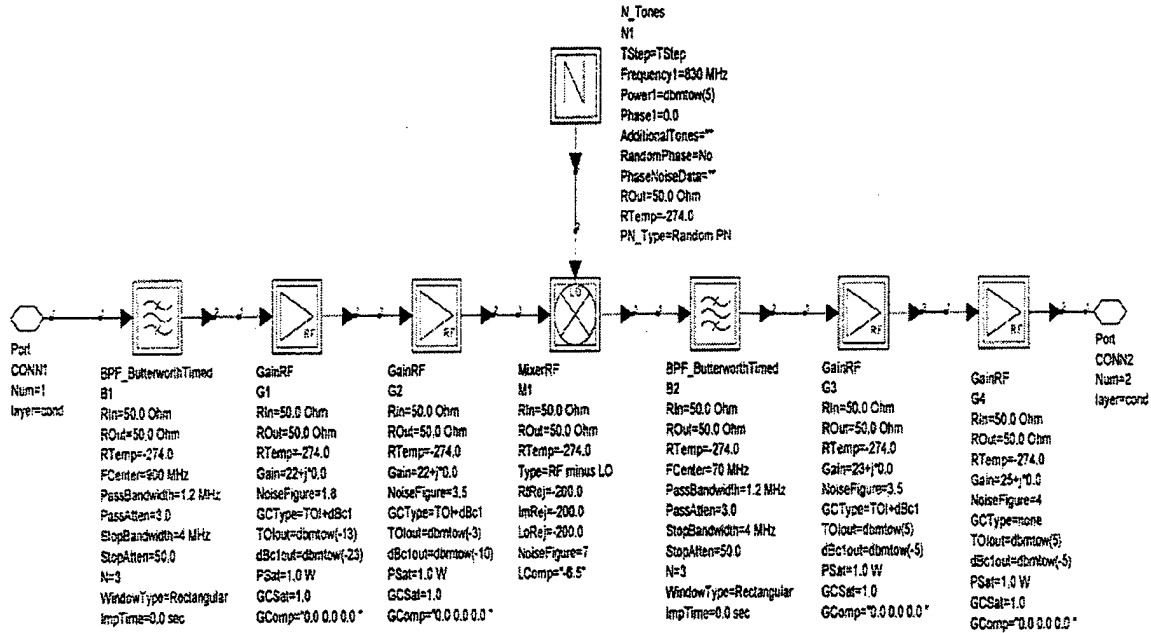

## RECEIVER

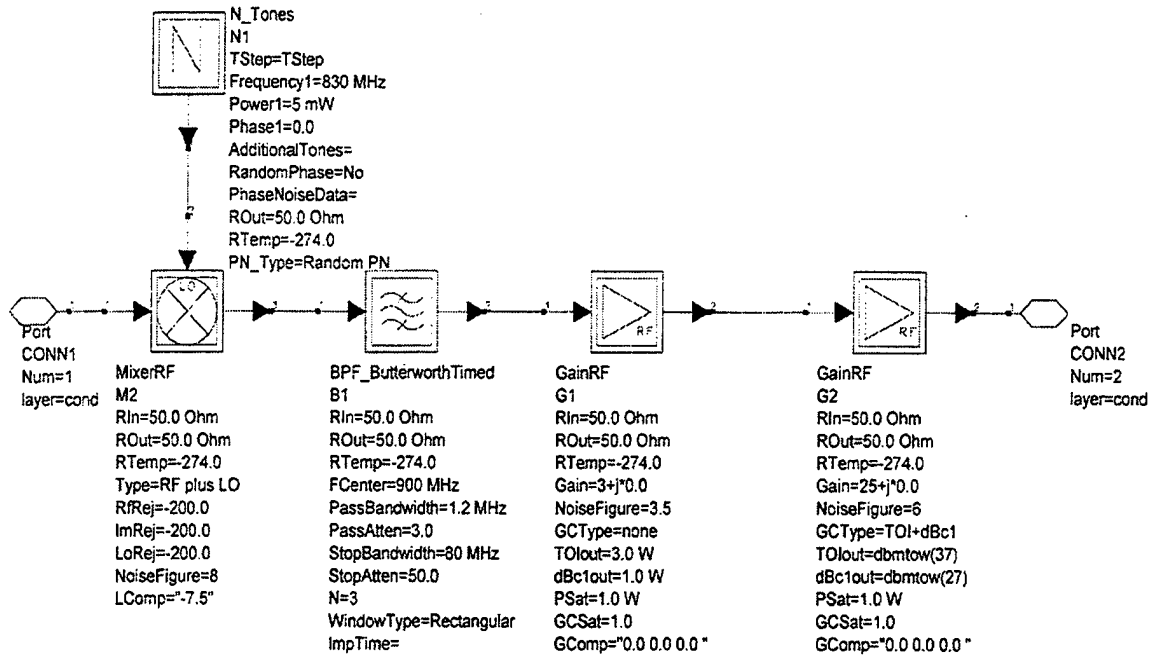

## DEMODULATOR

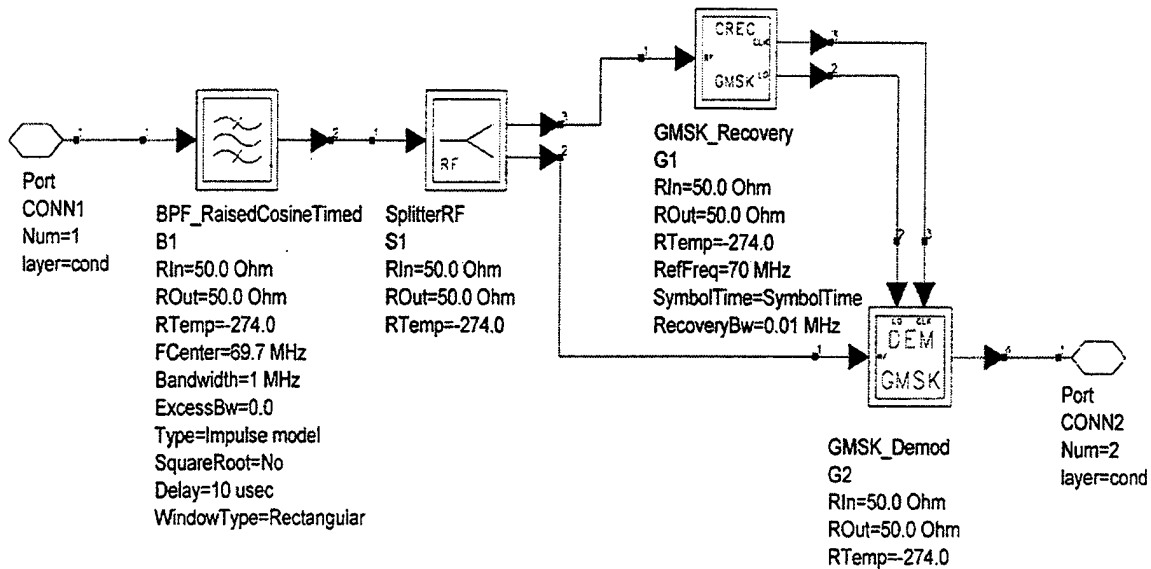

## APPENDIX C. MATLAB SIMULATIONS FOR EACH DATA SET

### FOURTH ORDER MOMENT & MAML FOR SAMPLE TIME = 92.592 nsec

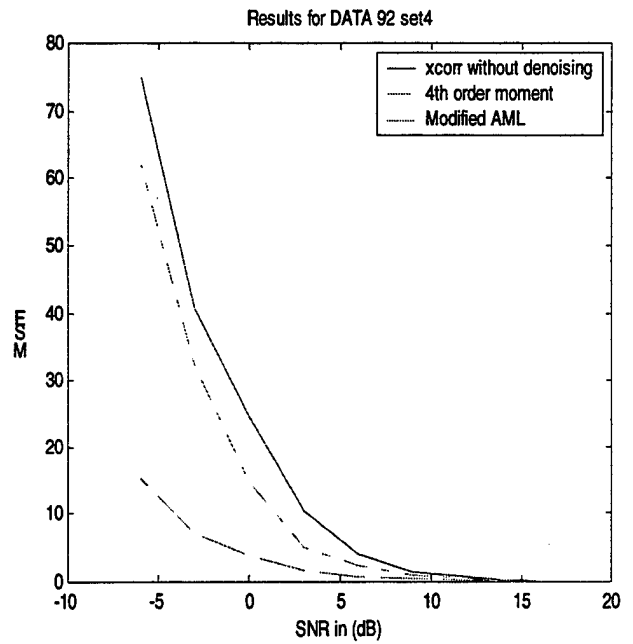
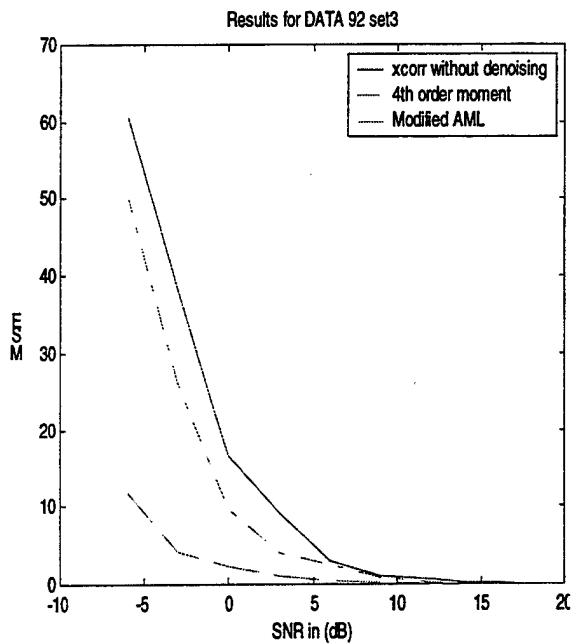
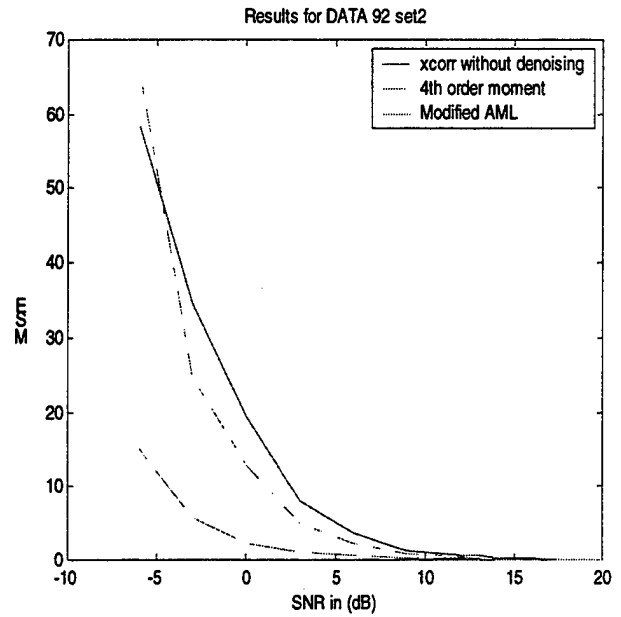
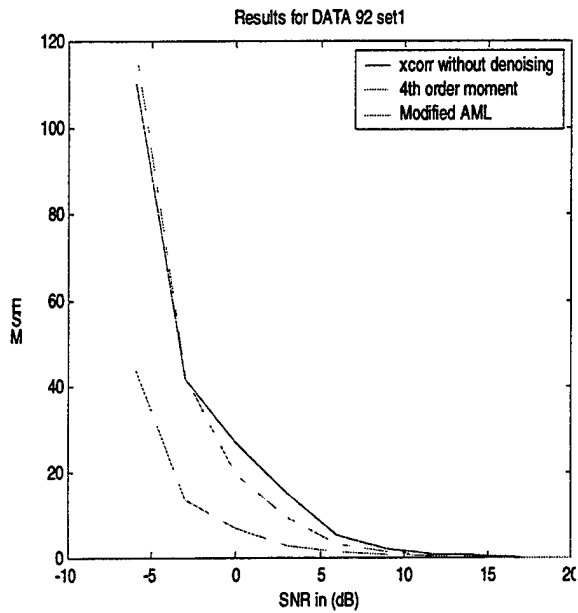

# FOURTH ORDER MOMENT & MAML FOR SAMPLE TIME = 185.185 nsec

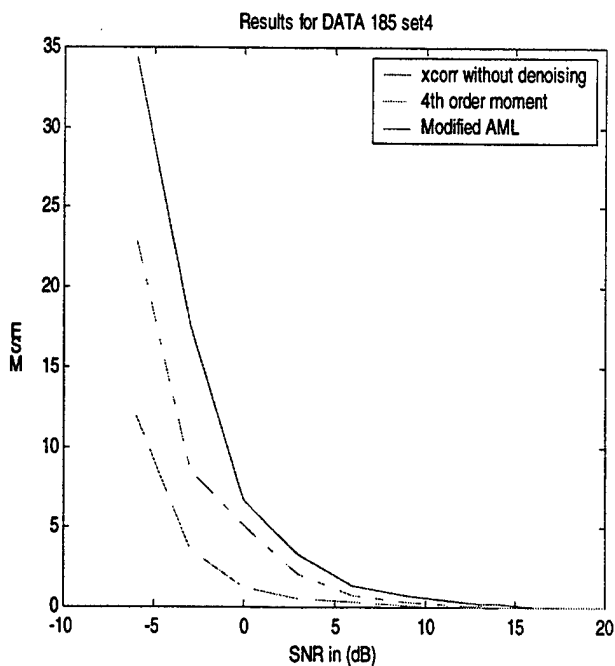
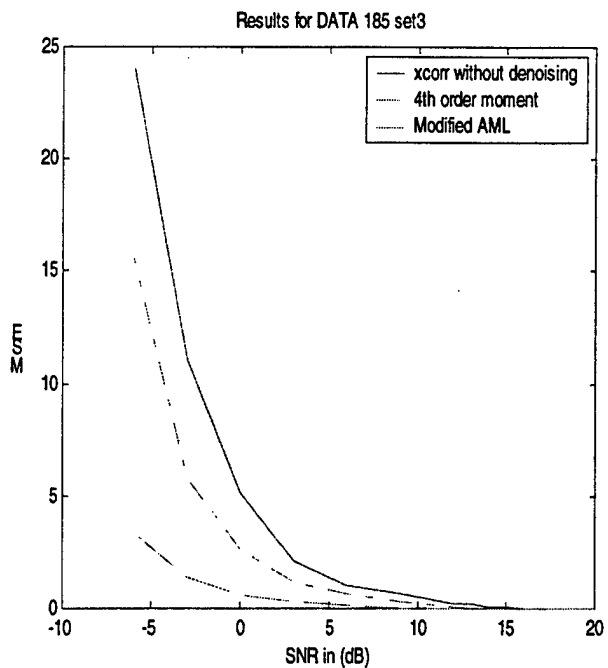
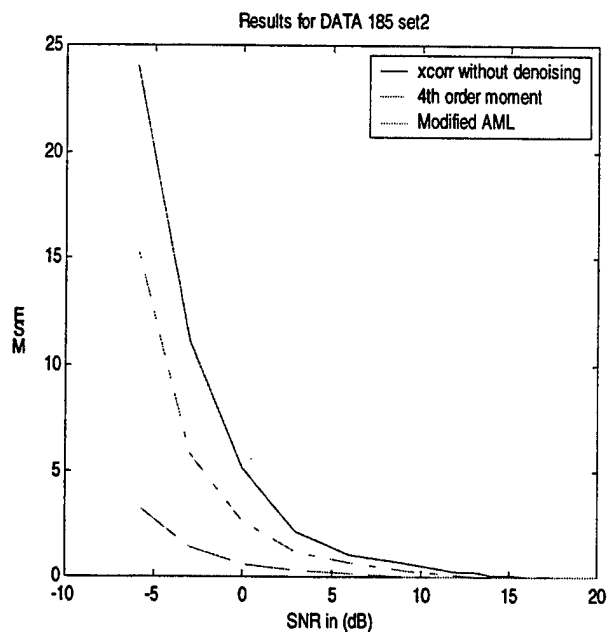
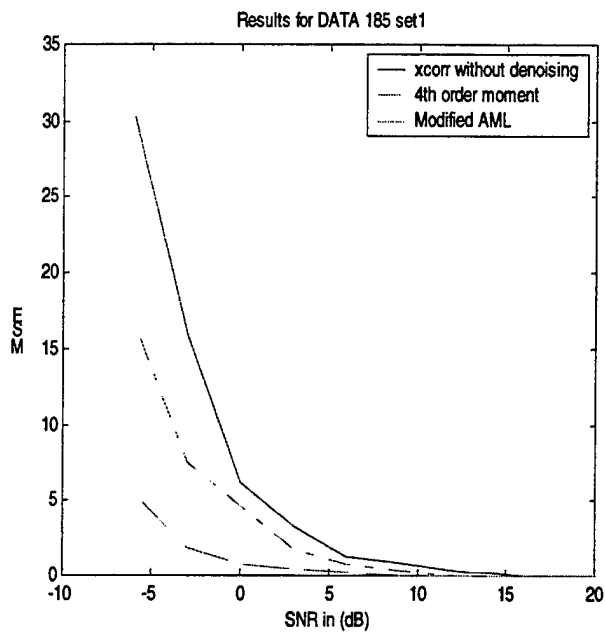

FOURTH ORDER MOMENT & MAML FOR SAMPLE TIME = 370.37 nsec

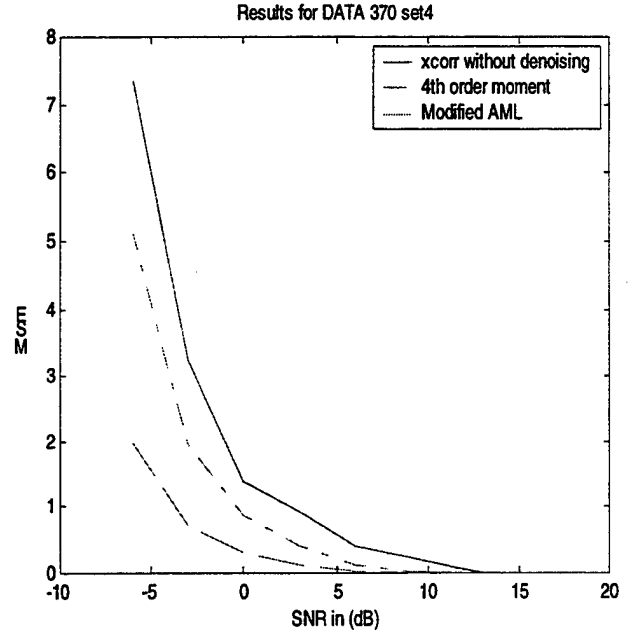
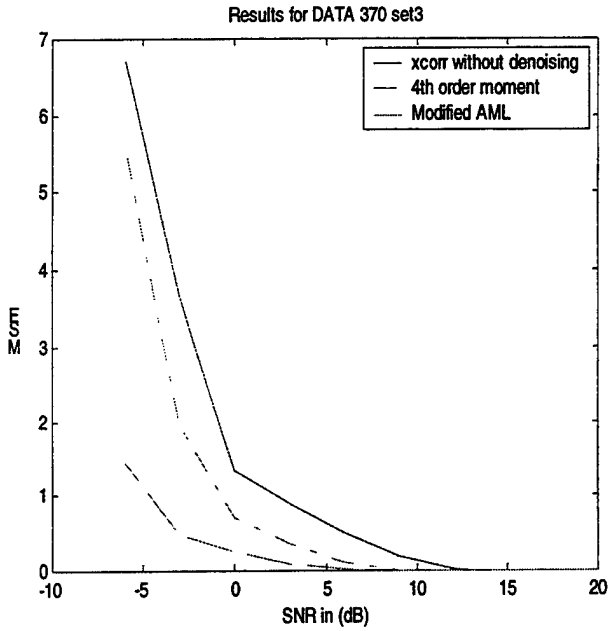
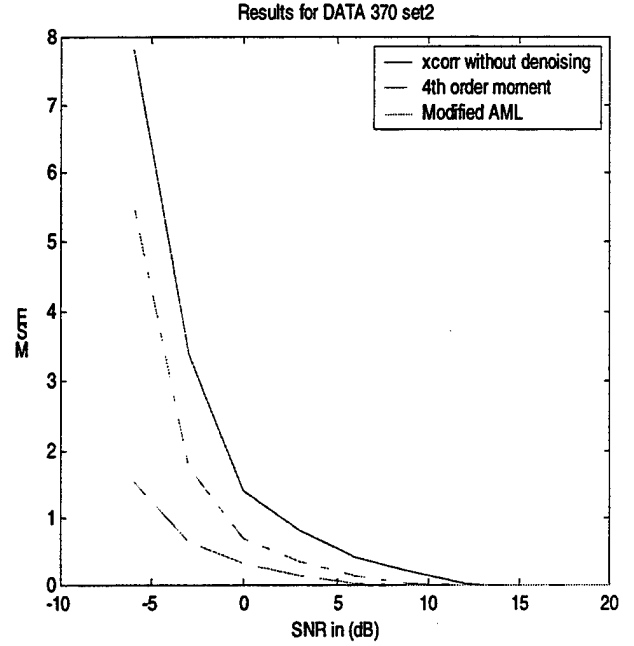
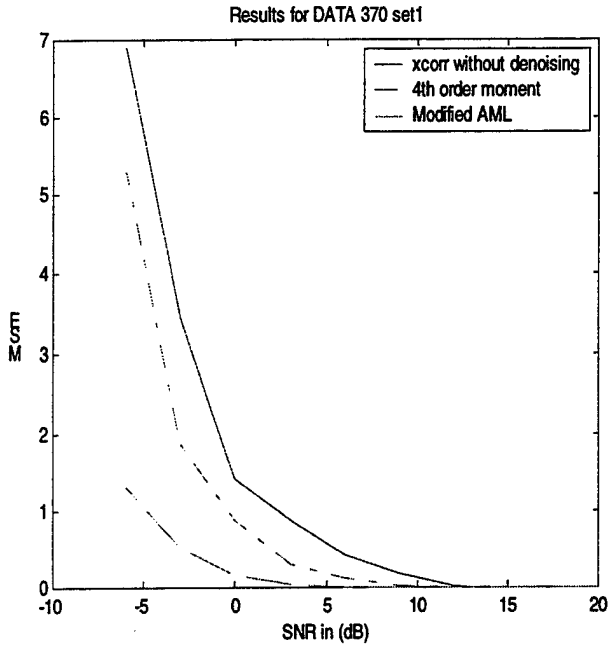

## APPENDIX D. MATLAB CODES

### FOURTH-ORDER MOMENT DENOISING TECHNIQUE

```
%*****
%*****
%*****
%*****
% Denoise_sta: Wavelet Denosing Based on The Fourth Order
Moment
%
% SYNTAX: y=Denoise_sta(xn,yn)
%
% INPUT: xn = Received signal from first receiver
%        yn = Received signal from second receiver
%
% OUTPUT: y = Denoised signal Xn based on Yn statistics
%
% SUB_FUNC: None
% Written by Spiros Mantis
%*****
%*****
%*****
%*****

function y=Denoise_sta(xn,yn);

xyn=xcorr(xn,yn,'biased');
[sigmas b]=max(xyn);
rx=xcorr(xn,'biased');
maxx=rx(length(xn));
ry=xcorr(yn,'biased');
maxy=ry(length(yn));
sigman1=maxx-sigmas;
sigman2=maxy-sigmas;

lamdax=3.1*sigman1^2;
lamday=3.1*sigman2^2;

nx=floor(log2(length(xn)));
ny=floor(log2(length(yn)));
```

```

[cx lx]=wavedec(xn,nx,'db4');
[cy ly]=wavedec(yn,ny,'db4');

dxc=[];
for i=1:nx
    d=detcoef(cx,lx,i);
    dl=length(d);
    A=(1/dl)*sum(d.^4);

    if A<lamdax
        dc=zeros(1,dl);
    else
        dc=d;
    end

    dxc=[dc dxc];
end

a=appcoef(cx,lx,'db4',nx);
al=length(a);
A=(1/al)*sum(a.^4);

if A<lamdax
    ac=zeros(1,al);
else
    ac=a;
end

dxc=[ac dxc];

xd=waverec(dxc,lx,'db4');

y=xd;

```

```

%*****
%*****
%*****
%*****
% Modified_tez6: This is a test program for wavelet
denosing
%     based on the fourth order moment technique.
%     GSM signal is used.
%
% SYNTAX: Modified_tez6
%
% INPUT: None
%
% OUTPUT: Mean square error versus SNR
%
% SUB_FUNC: Denoise_sta.m
% Written by Spiros Mantis
%*****
%*****
%*****
%*****

clear all

%gsm_set; %Configuration variables created in memory.
% these are:
    % Tb(= 3.692e-6)
    % BT(= 0.3)
    % OSR(= 4)
    % SEED(= 931316785)
    % INIT_L(= 260)

%data=data_gen(INIT_L); % this creates a binary data
%[tx_burst,I,Q]=gsm_mod(Tb,OSR,BT,data,TRAINING);

%s=I+j*Q;
data_370_set4
s=transpose(s2);
s1=length(s);
pow=(1/s1)*sum(abs(s).^2);

K=100     % number of realizations
rand('seed',40);
f=150*rand(1,K);

```

```

delay=floor(f);
delay(1:K/2)=-delay(1:K/2); % delay is between -150 to +150

n=[20 18 17 16 15 14 13 12 9 6 3 0 -3 -6];
SNR=10.^(n./10);

for k=1:length(SNR)

    oran=SNR(k)
    for i=1:K

        x=[zeros(1,200) s zeros(1,224)];
        y=[zeros(1,200+delay(i)) s zeros(1,224-delay(i))];

        randn('state',2*(i+j));
        noi1_real=sqrt(pow/(2*oran))*randn(1,1024);

        randn('state',3*(i+j));
        noi1_imag=sqrt(pow/(2*oran))*randn(1,1024);

        randn('state',4*(i+j));
        noi2_real=sqrt(pow/(2*oran))*randn(1,1024);

        randn('state',5*(i+j));
        noi2_imag=sqrt(pow/(2*oran))*randn(1,1024);

        noi1=noi1_real+j*noi1_imag;
        noi2=noi2_real+j*noi2_imag;

        xn=x+noi1; % x + noise
        yn=y+noi2; % y + noise

        % TDOA calculation with xcorr( without denoising)

        xy=xcorr(xn,yn); % correlation of x and y with xcorr
        [a1 b1]=max(real(xy));

        er1(i)=delay(i)-(b1-1024);

    % Fourth order moment denoise

```

```

X_real=Denoise_sta(real(xn),real(yn));
X_imag=Denoise_sta(imag(xn),imag(yn));
Y_real=Denoise_sta(real(yn),real(xn));
Y_imag=Denoise_sta(imag(yn),imag(xn));
X=X_real+j*X_imag;
Y=Y_real+j*Y_imag;
XY=xcorr(X,Y); % Correlation of X and Y (denoised)
[a2 b2]=max(real(XY));

er10(i)=delay(i)-(b2-1024);

end

error10a370set4(k)=(1/length(er10))*sum(er10.^2);
error1sta370set4(k)=(1/length(er1))*sum(er1.^2);

H10a370set4(k,:)=er10;
Hsta370set4(k,:)=er1;

end

figure(6)
k=[20 18 17 16 15 14 13 12 9 6 3 0 -3 -6];
plot(k,error1sta370set4(1:14),'o',k,error10a370set4(1:14),'
x',k,error1sta370set4(1:14),k,error10a370set4(1:14))
legend('xcorr without denoising','sta')
title('4TH ORDER method with cross corellation after
denoise; 100 realizations of data_370_set4')
ylabel('MSE')
xlabel('SNR')
figure(7)
plot(1:2047,xy)
title('Correlation Function of x and y signals w/noise')
figure(8)
plot(1:2047,XY)
title('Correlation Function of x and y signals without
noise')

```

save error10a370set4;  
save error1sta370set4;

save Hsta370set4;  
save H10a370set4;

MODIFIED APPROXIMATE MAXIMUM LIKELIHOOD DENOISING  
TECHNIQUE

```
%*****  
*****  
%*****  
*****  
% Denoise: Approximate maximum-likelihood delay estimation  
%   via orthogonal wavelet transform. In this function,  
%   we assumed that noise is Gaussian noise and it has  
%   a  
%   flat freq response. We modify each detail function  
%   by multiplying modified AML coefficient based on  
%   the signal and noise powers.  
%  
% SYNTAX: y=aml1(xn,yn)  
%  
% INPUT: xn = Received signal from first receiver  
%        yn = Received signal from second receiver  
%  
%  
% OUTPUT:  
%        y = Denoised signal  
%  
% SUB_FUNC: None  
% Written by Spiros Mantis  
%*****  
*****  
%*****  
*****
```

```
function y=denoise(xn,yn);  
  
xyn=xcorr(xn,yn,'biased');  
[sigmas b]=max(xyn);  
rx=xcorr(xn,'biased');  
maxx=rx(length(xn));  
ry=xcorr(yn,'biased');  
maxy=ry(length(yn));  
sigman1=maxx-sigmas;  
sigman2=maxy-sigmas;
```

```

nx=floor(log2(length(xn)));
ny=floor(log2(length(yn)));

[cx lx]=wavedec(xn,nx,'db4');
[cy ly]=wavedec(yn,ny,'db4');

dxc=[];
for i=1:nx
    d=detcoef(cx,lx,i);
    dl=length(d);
    sigmad=(1/dl)*sum(d.^2);
    sigmasd=sigmad-sigman1;
    sigmaa(i)=(2^(nx-1))*sigmasd;
    if sigmasd<=0
        wd=0;
    else

wd=sigmasd/(sigman1*sigman2+sigmasd*(sigman1+sigman2));
        end
        dc=wd*d;
        dxc=[dc dxc];
    end

a=appcoef(cx,lx,'db4',nx);
al=length(a);
aux=sum(sigmaa);
sigmasa=((2^nx))*sigmas-aux;
if sigmasa<=0
    wa=0;
else
    wa=sigmasa/(sigman1*sigman2+sigmasa*(sigman1+sigman2));
end
ac=wa*a;
dxc=[ac dxc];

xd=waverec(dxc,lx,'db4');
y=xd;

```

```

%*****
*****
%*****
*****
%
% Modified_tez5: This is a test program for modified AML
technique. In this
%     program, we used GSM signal.
%
% SYNTAX: Modified_tez5
%
% INPUT: None
%
% OUTPUT: Mean square error versus SNR
%
% SUB_FUN: Denoise.m
% Written by Spiros Mantis
%*****
*****
%*****
*****

clear all

gsm_set;    % Configuration variables created in memory.
%these are:
    % Tb(= 3.692e-6)
    % BT(= 0.3)
    % OSR(= 4)
    % SEED(= 931316785)
    % INIT_L(= 260)

data=data_gen(INIT_L); % this creates a binary data
[tx_burst,I,Q]=gsm_mod(Tb,OSR,BT,data,TRAINING);

s=I+j*Q;
s1=length(s);
pow=(1/s1)*sum(abs(s).^2);

K=100      % number of realizations
rand('seed',40);
f=150*rand(1,K);

```

```

delay=floor(f);
delay(1:K/2)=-delay(1:K/2); % delay is between -150 to +150

n=[20 18 17 16 15 14 13 12 9 6 3 0 -3 -6];
SNR=10.^(n./10);

for k=1:length(SNR)

    oran=SNR(k)
    for i=1:K

        x=[zeros(1,200) s zeros(1,224)];
        y=[zeros(1,200+delay(i)) s zeros(1,224-delay(i))];

        randn('state',2*(i+j));
        noi1_real=sqrt(pow/(2*oran))*randn(1,1024);

        randn('state',3*(i+j));
        noi1_imag=sqrt(pow/(2*oran))*randn(1,1024);

        randn('state',4*(i+j));
        noi2_real=sqrt(pow/(2*oran))*randn(1,1024);

        randn('state',5*(i+j));
        noi2_imag=sqrt(pow/(2*oran))*randn(1,1024);

        noi1=noi1_real+j*noi1_imag;
        noi2=noi2_real+j*noi2_imag;

        xn=x+noi1; % x + noise
        yn=y+noi2; % y + noise

        % TDOA calculation with xcorr( without denoising)

        xy=xcorr(xn,yn); % correlation of x and y with xcorr
        %(with the presence of noise)
        [a1 b1]=max(real(xy));

        er1(i)=delay(i)-(b1-1024);

        %AML

        x_real=denoise(real(xn),real(yn)); % Denoising of the
        %received signals
    end
end

```

```

y_real=denoise(real(yn),real(xn));
x_imag=denoise(imag(xn),imag(yn));
y_imag=denoise(imag(yn),imag(xn));

X=x_real+j*x_imag;
Y=y_real+j*y_imag;

XY=xcorr(X,Y); % Correlation of X and Y (denoised)
[a2 b2]=max(real(XY));

er8(i)=delay(i)-(b2-1024);

end

error8a(k)=(1/length(er8))*sum(er8.^2);
error1a(k)=(1/length(er1))*sum(er1.^2);

H8a(k,:)=er8;
H1a(k,:)=er1;

end

figure(6)
k=[20 18 17 16 15 14 13 12 9 6 3 0 -3 -6];
plot(k,error1a(1:14),'o',k,error8a(1:14),'x',k,error1a(1:14)
),k,error8a(1:14))
legend('xcorr without denoising','aml')
title('Denoise AML method with cross corellation after
denoise; 100 realizations')
ylabel('MSE')
xlabel('SNR')
figure(7)
plot(1:2047,xy)
title('Correlation Function of x and y signals w/noise')
figure(8)
plot(1:2047,XY)
title('Correlation Function of x and y signals without
noise')

save error8a;
save error1a;

save H1a;
save H8a;

```

## LIST OF REFERENCES

1. Drane, C., Macnaughtan, M., and Scott, C., "Positioning GSM Telephones," *IEEE Communications Magazine*, pp 46-59, April 1998
2. Mehrotra, A., *GSM System Engineering*, Norwood, MA, Artech House Publishers, 1997.
3. Rappaport, T. S., *Wireless Communications: Principles & Practice*, Upper Saddle River, NJ, Prentice Hall, 1996
4. Ibbetson, L. J., and Lopes, L. B., "Performance Comparison of Alternative Diversity Schemes Using a GSM Radio Link Simulation," *Mobile and Personal Communications*, pp. 11-15, December 1993.
5. Joyce, R. M., Ibbetson, L. J., and Lopes, L. B., "Prediction of GSM Performance Using Measured Propagation Data," University of Leeds, United Kingdom, 1996.
6. Hellebrandt, M., Mathar, R., and Scheibenbogen, M., "Estimating Position and Velocity of Mobiles in a Cellular Radio Network," *IEEE Transactions on Vehicular Technology*, Vol. 46, No. 1, February 1997.
7. Aktas, U., and Hippenstiel, R., "Localization of GSM Signals Based on Fourth Order Wavelet Denoising," 33<sup>rd</sup> Asilomar Conference on Signals, Systems, and Computers, p 457-461, Oct 24-27, 1999, Pasific Grove, CA.
8. Hippenstiel, R., T.T. Ha, and Aktas, U., "Localization of Wireless Emitters Based on the Time Difference of Arrival (TDOA) and Wavelet Denoising," NPSEC-99-006, Naval Postgraduate School, Monterey, Ca, May 1999.
9. Rappaport, T. S., Reed, J. H., and Woerner, B. D., "Position Location Using Wireless Communications on Highways of the Future," *IEEE Communications Magazine*, pp 33-41, October 1996
10. Aktas, U., Time Difference of Arrival (TDOA) Estimation Using Wavelet Based Denoising, Master's Thesis, Naval Postgraduate School, Monterey, CA, March 1999.
11. Ferrari, A., and Alengrin, G., "Estimation of the Frequencies of a Complex Sinusoidal Noisy Signal Using Fourth Order Statistics," Universite de Nice-Sophia Antipolis, Nice, France, 1991.

12. Chan, Y. T., So, H. C., and Ching, P. C., "Approximate Maximum Likelihood Delay Estimation via Orthogonal Wavelet Transform," *IEEE Transactions on Signal Processing*, Vol. 47, No. 4, April 1999.
13. Hippenstiel, R., and Aktas, U., "Difference of Arrival Estimation Using Wavelets," 42<sup>nd</sup> Midwest Symposium on Circuits and Systems, p 1082-1085, Las Cruces, NM, August 8-11, 1999.

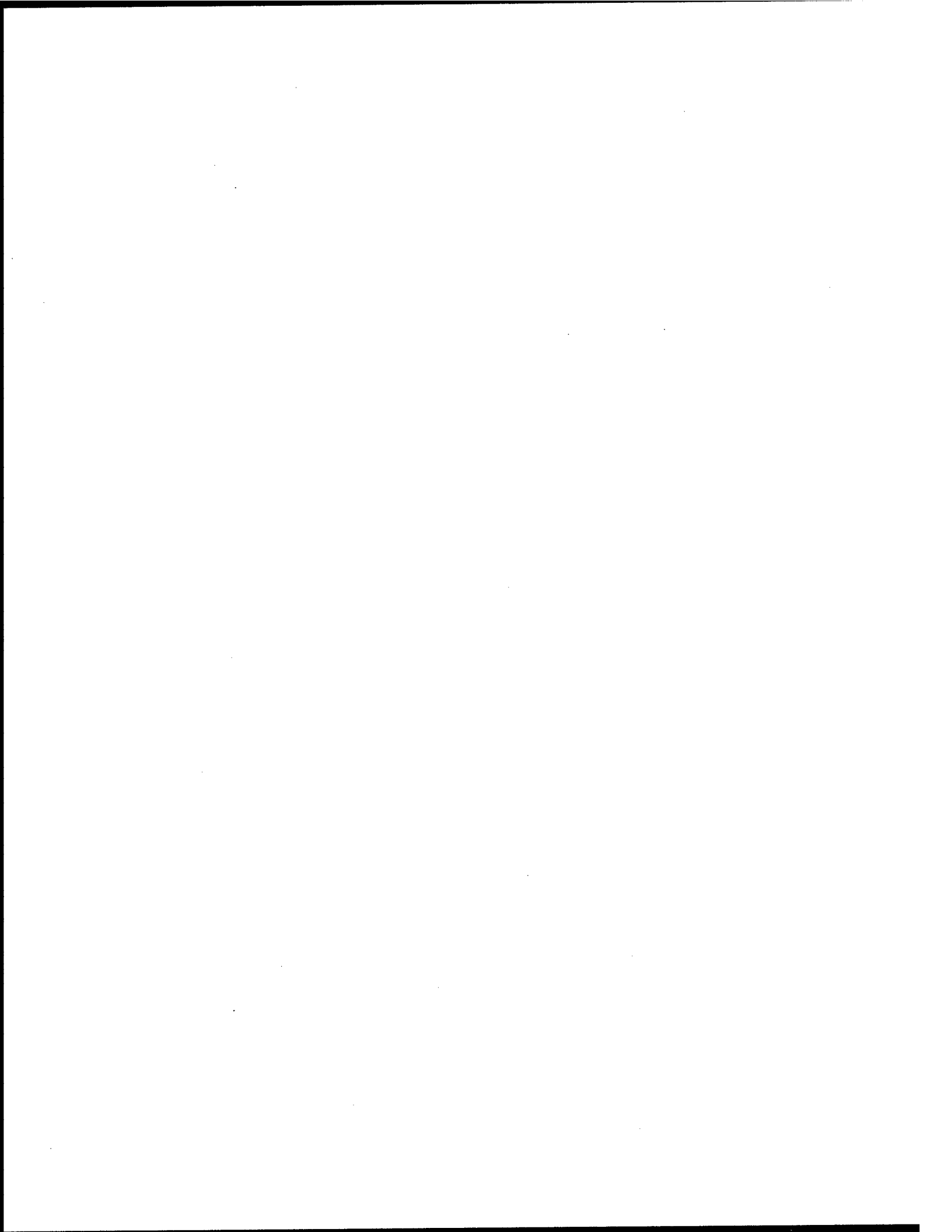

## INITIAL DISTRIBUTION LIST

	No. Copies
1. Defense Technical Information Center 8725 John J. Kingman Rd, STE 0944 Ft. Belvoir, VA 22060-6218	2
2. Dudley Knox Library, Code 52 Naval Postgraduate School 411 Dyer Road Monterey, CA 93943-5101	2
3. Research Office, Code 09 Naval Postgraduate School 589 Dyer Road Monterey, CA 93943-5138	1
4. Chairman, Code EC Department of Electrical and Computer Engineering Naval Postgraduate School 833 Dyer Road Monterey, CA 93943-5121	1
5. Professor Ralph Hippenstiel, Code EC/Hi Department of Electrical and Computer Engineering Naval Postgraduate School 833 Dyer Road Monterey, CA 93943-5121	3
6. Professor Tri T. Ha, Code EC/Ha Department of Electrical and Computer Engineering Naval Postgraduate School 833 Dyer Road Monterey, CA 93943-5121	1
7. Professor Alan Ross, Code SP/Ra Space Systems Academic Group Naval Postgraduate School Monterey, CA 93943-5121	1
8. TENCAP Office Department of the Navy CNO/N632 2000 Navy Pentagon Washington, D.C. 20350-2000	3