

NAVAL POSTGRADUATE SCHOOL
Monterey, California



THESIS

**SECOND GENERATION ULTRA HIGH
FREQUENCY (UHF) SATELLITE PROTOCOL**

by

Robert L. Franco

June 2000

Thesis Advisor:
Second Reader:

Bert Lundy
John K. O'Leary

Approved for public release; distribution is unlimited

DTIC QUALITY INSPECTED 4

20000807 060

REPORT DOCUMENTATION PAGE			Form Approved OMB NO. 0704-0188	
<p>Public Reporting burden for this collection of information is estimated to average 1 hour per response, including the time for reviewing instructions, searching existing data sources, gathering and maintaining the data needed, and completing and reviewing the collection of information. Send comment regarding this burden estimates or any other aspect of this collection of information, including suggestions for reducing this burden, to Washington Headquarters Services, Directorate for information Operations and Reports, 1215 Jefferson Davis Highway, Suite 1204, Arlington, VA 22202-4302, and to the Office of Management and Budget, Paperwork Reduction Project (0704-0188.) Washington, DC 20503.</p>				
1. AGENCY USE ONLY (Leave Blank)		2. REPORT DATE June 2000		3. REPORT TYPE AND DATES COVERED Master's Thesis
4. TITLE AND SUBTITLE Second Generation Ultra High Frequency (UHF) Satellite Protocol			5. FUNDING NUMBERS	
6. AUTHOR(S) Franco, Robert L.				
7. PERFORMING ORGANIZATION NAME(S) AND ADDRESS(ES) Naval Postgraduate School Monterey CA 93943-5000			8. PERFORMING ORGANIZATION REPORT NUMBER	
9. SPONSORING / MONITORING AGENCY NAME(S) AND ADDRESS(ES) SPAWARSYS Center, 53560 Hull Street, San Diego, CA 92152			10. SPONSORING / MONITORING AGENCY REPORT NUMBER	
11. SUPPLEMENTARY NOTES The views expressed in this thesis are those of the author and do not reflect the official policy or position of the Department of Defense or the U.S. Government.				
12 a. DISTRIBUTION / AVAILABILITY STATEMENT Approved for public release; distribution is unlimited.			12 b. DISTRIBUTION CODE	
13. ABSTRACT (Maximum 200 words) An attempt is being made to provide the reader with an appreciation for the complexity required to upgrade an existing Ultra High Frequency (UHF) 25 kHz tactical communications protocol. This thesis defines the satellite discipline and protocols for a second generation of the Officer in Tactical Command Information Exchange Subsystem (OTCIXS II). This thesis provides the detailed information necessary for the implementation of the OTCIXS II communications protocols. It can be used to define and develop the OTCIXS II satellite link software. The OTCIXS II network protocol will consist of distinct protocol layers: Physical, Data Link, and Network layers. The Transport layer which provides the actual computer to computer transfer of messages will not be covered in this thesis.				
1. SUBJECT TERMS OTICXS II Satellite Link Protocol			15. NUMBER OF PAGES 247	
			16. PRICE CODE	
17. SECURITY CLASSIFICATION OR REPORT Unclassified	18. SECURITY CLASSIFICATION ON THIS PAGE Unclassified	19. SECURITY CLASSIFICATION OF ABSTRACT Unclassified	20. LIMITATION OF ABSTRACT UL	

THIS PAGE INTENTIONALLY LEFT BLANK

Approved for public release; distribution is unlimited

**SECOND GENERATION ULTRA HIGH FREQUENCY (UHF) SATELLITE
PROTOCOL**

Robert L. Franco
SPAWAR SYSTEMS CENTER
San Diego (SSC-SD) California, 92152
B.S., University of Northern Colorado, 1975

Submitted in partial fulfillment of the
requirements for the degree of

MASTER OF SCIENCE IN SOFTWARE ENGINEERING

from the

**NAVAL POSTGRADUATE SCHOOL
June 2000**

Author:

Robert L. Franco

Approved by:

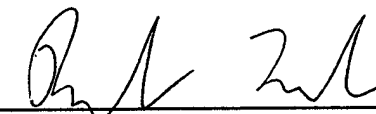
Professor Bert Lundy, Thesis Advisor

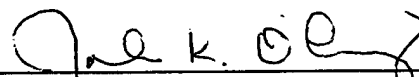
John K. O'Leary, Second Reader

Dan Boger, Chair Computer Science Department

THIS PAGE INTENTIONALLY LEFT BLANK

ABSTRACT

An attempt is being made to provide the reader with an appreciation for the complexity required to upgrade an existing Ultra High Frequency (UHF) 25 kHz tactical communications protocol. This thesis defines the satellite discipline and protocols for a second generation of the Officer in Tactical Command Information Exchange Subsystem (OTCIXS II). This thesis provides the detailed information necessary for the implementation of the OTCIXS II communications protocols. It can be used to define and develop the OTCIXS II satellite link software. The OTCIXS II network protocol will consist of distinct protocol layers: Physical, Data Link, and Network layers. The Transport layer which provides the actual computer to computer transfer of messages will not be covered in this thesis.

THIS PAGE INTENTIONALLY LEFT BLANK

DISCLAIMER STATEMENT

The views, opinions and/or findings contained in this report are those of the author(s) and should not be construed as an official Department of the US Navy position, policy or decision, unless so designated by the documentation.

THIS PAGE INTENTIONALLY LEFT BLANK

TABLE OF CONTENTS

I. INTRODUCTION.....	1
A. PURPOSE	1
B. FUNCTIONAL SUMMARY OF OTCIXS II	1
1. Communications Link	2
a. Intranetwork Communications	2
b. Internetwork Communications.....	2
2. OTCIXS II Subscriber Equipment Suites.....	3
a. Surface Ship	4
b. Submarine	6
c. Shore	7
3. Subscriber Identification	9
a. Subscriber Data	10
b. Nonscheduled and Scheduled Broadcasts	11
4. Message Identification	12
a. Message Length	12
b. Message Precedence	12
c. Network Control	13
C. CONTENT DESCRIPTION	13
II. INTERFACE SUMMARY CROSS-INDEX	15
A. GENERAL	15
B. SIGNAL SUMMARY CROSS-INDEX - NET CONTROL	
STATION TO SUBSCRIBER	15

- C. SIGNAL SUMMARY CROSS-INDEX - SUBSCRIBER TO
NET CONTROL STATION 15
- D. SIGNAL SUMMARY CROSS-INDEX - SUBSCRIBER TO
SUBSCRIBER 15
- III. SIGNAL DEFINITION LIST 21
 - A. GENERAL 21
 - 1. Protocol Layers 21
 - 2. General Definitions 21
 - B. PHYSICAL LAYER SIGNAL DEFINITION LIST 23
 - C. DATA LINK LAYER SIGNAL DEFINITION LIST 23
 - D. NETWORK LAYER SIGNAL DEFINITION LIST 23
- IV. NARRATIVE SIGNAL FLOW TABLE 41
 - A. GENERAL 41
 - B. SIGNAL FLOW TABLES 41
 - 1. Physical Layer 41
 - 2. Data Link and Network Layer 41
- V. COMMUNICATION CONTROLS AND CONVENTIONS..... 65
 - A. GENERAL..... 65
 - B. COMMUNICATION CONTROLS 65
 - 1. Physical Layer 66
 - a. User Baseband 66
 - b. Radio Frequency 67
 - (1) DAMA Mode 67

(2) Non-DAMA Mode	68
c. Signal Timing and Sequencing	68
(1) DAMA Mode	68
(a) Transmission	68
(b) Reception	71
(2) Non-DAMA Mode	71
(a) Transmission	71
(b) Reception	72
d. Crypto Error Handling	76
2. Data Link Layer	82
3. Network Layer	82
a. Net Cycle Structure	82
b. Net Cycle Initiation	83
c. Net Cycle Type	85
(1) Idle Cycle	85
(2) Busy Cycle	85
d. Net Cycle Timing	85
(1) DAMA Mode	85
(2) Non-DAMA Mode	87
C. COMMUNICATIONS CONVENTIONS	88
1. Net Participation Modes	88
a. Net Control Station	88
b. Subscriber	97

2. Initialization/Startup	98
3. RATS Management	99
4. Link Access Request Submission	99
a. RRTU	99
b. Piggyback RR	100
(1) Existing Service Requirements	101
(2) Predicted Service Requirements	102
5. Link Access Request Reception	103
a. Nonscheduled Transmission of Flash Precedence STU	103
b. Nonscheduled Transmission of Immediate Precedence STU	104
c. Scheduled Broadcast STU Transmission STU	104
6. Contention Resolution Algorithm	105
7. Link Access Request Servicing	105
8. Subscriber Data Transmission	107
9. Subscriber Data Reception	110
a. Subscriber	110
b. Net Control Station	111
(1) STU Acknowledgement	111
(2) Scheduled Broadcast Continuation	112
(3) Piggyback Request Information	113
10. Transfer of NCS Responsibilities	113
VI. DATA UNIT DESCRIPTIONS	115
A. GENERAL	115

B. DATA UNIT DESCRIPTION - NET CONTROL STATION TO SUBSCRIBER	115
C. DATA UNIT DESCRIPTION - SUBSCRIBER TO NET CONTROL STATION	116
D. DATA UNIT DESCRIPTION - SUBSCRIBER TO SUBSCRIBER	116
APPENDIX A. LIST OF ACRONYMS AND ABBREVIATIONS	137
APPENDIX B. CYCLIC REDUNDANCY CHECK SEQUENCE GENERATION	143
APPENDIX C. OTCIXS II SIMULATION RESULTS.....	147
Section C1. OTCIXS II SIMULATION PERFORMANCE RESULTS.....	147
Section C2. DESCRIPTION	153
Section C3. PERFORMANCE RESULTS	163
Section C4. OTCIXS MODEL NETWORK DESCRIPTION	187
APPENDIX D. OTICXS II MODEL SIMULATION SETUP FILE FORMAT	209
APPENDIX E. SETUP FILE STANDARD VALUES	219
LIST OF REFERENCES	221
INITIAL DISTRIBUTION LIST	225

THIS PAGE INTENTIONALLY LEFT BLANK

LIST OF FIGURES

Figure 1-1. OTCIXS II Intranetwork Connectivity.....	4
Figure 1-2. OTCIXS II Internetwork Connectivity	5
Figure 1-3. OTCIXS II Worldwide Connectivity by TADIXS	6
Figure 1-4. Surface Ship Configuration with OTCIXS II	8
Figure 1-5. Submarine Configuration with OTCIXS II	9
Figure 1-6. OTCIXS II Shore Gateway Configuration	11
Figure 5-1. OTCIXS II Protocol Layers	66
Figure 5-2. DAMA Configuration Physical Signals	69
Figure 5-3. DAMA Configuration Physical Signal Timing: 1200 bps KG-84A Transmit.....	70
Figure 5-4. DAMA Configuration Physical Signal Timing: 1200 bps KG-84A Receive.....	73
Figure 5-5. DAMA Configuration Physical Signal Timing: 2400 bps KG-84A Transmit.....	74
Figure 5-6. DAMA Configuration Physical Signal Timing: 2400 bps KG-84A Receive.....	75
Figure 5-7. Non-DAMA Configuration Physical Signals	76
Figure 5-8. Non-DAMA Configuration Physical Timing: 2400 bps KG-84A Transmit	78
Figure 5-9. Non-DAMA Configuration Physical Timing: 2400 bps KG-84A Receive.....	79
Figure 5-10. Non-DAMA Configuration Physical Signal Timing: 4800 bps	

KG-84A Transmit.....	80
Figure 5-11. Non-DAMA Configuration Physical Signal Timing: 4800 bps	
KG-84A Receive.....	81
Figure 5-12. Idle Cycle Structure and Use	86
Figure 5-13. Busy Cycle Structure and Use	87
Figure 5-14. DAMA Mode OTCIXS II Timing - CTS	89
Figure 5-15. DAMA Mode OTCIXS II Timing - RATS	90
Figure 5-16. DAMA Mode OTCIXS II Timing - STTS	91
Figure 5-17. Non-DAMA Mode OTCIXS II Timing - CTS	92
Figure 5-18. Non-DAMA Mode OTCIXS II Timing - RATS	93
Figure 5-19. Non-DAMA Mode OTCIXS II Timing - STTS	94
Figure 5-20. Extended RATS Structure and Use	101
Figure 6-1. Net Control Block (NCB) Transmission Unit	117
Figure 6-2. Reservation Request (RR) Transmission Unit	125
Figure 6-3. Subscriber Transmission Unit	128
Figure 6-4. Network Message	134
Figure 6-5 Data Link Packet Format.....	135
Figure B-1. CRC Generator Algorithm.....	144
Figure B-2. 8080 Listing of CRC Generator.....	145
Figure C3-1. OTCIXS I vs. OTCIXS II Minimal Subscriber Queue	
Wait Time.....	166
Figure C3-2. OTCIXS I vs. OTCIXS II Minimal Subscriber to Subscriber	
Service Time.....	166

Figure C3-3. OTCIXS I vs. OTCIXS II Maximum Subscriber Queue	
Wait Time.....	166
Figure C3-4. OTCIXS I vs. OTCIXS II Maximum Subscriber to Subscriber	
Service Time	167
Figure C3-5. OTCIXS II Minimum: non-Rescheduled vs. Piggy-Back Queue	
Wait Time.....	167
Figure C3-6. OTCIXS II Minimum: non-Rescheduled vs. Piggy-Back Service	
Time.....	169
Figure C3-7. OTCIXS II Minimum: non-Rescheduled vs. Frequent User	
Queue Wait Time.....	169
Figure C3-8. OTCIXS II Minimum: non-Rescheduled vs. Frequent User	
Service Time	169
Figure C3-9. OTCIXS II Maximum: non-Rescheduled vs. Piggy-Back Queue	
Wait Time	170
Figure C3-10. OTCIXS II Maximum: non-Rescheduled vs. Piggy-Back	
Service Time	171
Figure C3-11. OTCIXS II Maximum: non-Rescheduled vs. Frequent User	
Queue Wait Time	171
Figure C-12. OTCIXS II Maximum: non-Rescheduled vs. Frequent User	
Service Time.....	172

THIS PAGE INTENTIONALLY LEFT BLANK

LIST OF TABLES

Table 1-1. OTCIXS II TDPs Communicating Intranetwork	3
Table 1-2. TADIXS-A/OTCXS II TDPs Communicating Internetwork	4
Table 2-1. Physical Layer Signal Cross-Index.....	16
Table 2-2. NCS to Subscriber Signal Cross-Index	17
Table 2-3. Subscriber to NCS Signal Cross-Index	19
Table 2-4. Subscriber to Subscriber Signal Cross-Index	20
Table 3-1. Physical Signal Definition List	24
Table 3-2. Data Link Layer Signal Definition List	27
Table 3-3. NCS to Subscriber Signal Definition List	28
Table 3-4. Subscriber to NCS Signal Definition List	34
Table 3-5. Subscriber to Subscriber Signal Definition List	37
Table 4-1. Physical Layer Signal Flow	42
Table 4-2. Data Link and Network Layer Signal Flow	50
Table 5-1. TU Transmissions per Net Cycle	84
Table 6-1. Net Control Station to Subscriber Data Unit Summary	115
Table 6-2. Subscriber to Net Control Station Data Unit Summary	116
Table 6-3. Subscriber to Subscriber Data Unit Summary	116
Table B-1. Sample Inputs/Outputs for CRC Generator	143
Table C3-1. OTCIXS I Simulation Data Results (non-DAMA Mode in seconds)	166
Table C3-2. OTCIXS II Minimal Cycle Time (non-DAMA Mode in seconds).....	166

Table C3-3. OTCIXS II Minimal Cycle Time (DAMA Mode in seconds).....	166
Table C3-4. OTCIXS II Maximum Cycle Time (non-DAMA Mode in seconds)	167
Table C3-5. OTCIXS II Maximum Cycle Time (DAMA Mode in seconds).....	167
Table C3-6. OTCIXS II Minimal Cycle Time/Piggy-Backed Rescheduling (non-DAMA Mode in seconds)	169
Table C3-7. OTCIXS II Minimal Cycle Time/Piggy-Backed Rescheduling (DAMA Mode in seconds)	169
Table C3-8. OTCIXS II Minimal Cycle Time Frequent User Polling (non-DAMA Mode in seconds)	169
Table C3-9. OTCIXS II Minimum Cycle Time Frequent User Polling (DAMA Mode in seconds)	170
Table C3-10. OTCIXS II Maximum Cycle Time/Piggy-Backed Rescheduling (non-DAMA Mode in seconds)	171
Figure C3-11. OTCIXS II Maximum Cycle Time/Piggy-Backed Rescheduling (DAMA Mode in seconds).....	171
Figure C3-12. OTCIXS II Maximum Cycle Time Frequent User Polling (non-DAMA Mode in seconds)	172
Figure C3-13. OTCIXS II Maximum Cycle Time Frequent User Polling (DAMA Mode in Seconds)	172

I. INTRODUCTION

A. PURPOSE.

This thesis defines the satellite discipline and protocols for the second generation of the Officer in Tactical Command Information Exchange Subsystem (OTCIXS II). This document provides the detailed information necessary for the implementation of the OTCIXS II communications protocol. It could be used to define and develop the OTCIXS II satellite link software.

The OTCIXS II network protocol shall consist of distinct protocol layers: Physical, Data Link, and Network layers. The function supported by each of these layers are:

1. Physical layer - The Physical layer controls interaction of OTCIXS II equipment suites at the hardware level.
2. Data Link layer - The Data Link layer ensures an error-free transfer of information between OTCIXS II subscribers.
3. Network layer - The Network layer controls the allocation of the network resources among the OTCIXS II subscribers and provides the vehicle for transporting OTCIXS II subscriber to subscriber transactions.

A fourth layer, the Transport layer, provides the actual subscriber to subscriber transaction service; that is, the transfer of formatted computer-to-computer data and teletype messages. This layer is beyond the scope of this thesis. A description of this transfer layer protocol is defined in the Tactical Data Information Exchange Subsystem (TADIXS) Interface Design Specification, Volume I.

B. FUNCTIONAL SUMMARY OF THE OTCIXS II.

OTCIXS II will support inter and intra battle group Tactical communications,

including delivery of Over-the-Horizon Targeting (OTH-T) information. OTCIXS II will support ship-ship, shore-ship, and ship-shore tactical data exchange between user systems as described in the following subparagraphs.

1. Communications Link.

OTCIXS II operations are transparent to the use of either Fleet Satellite (FLTSAT) or Leased Satellite (LEASAT) satellites. When functioning in Demand Assigned Multiple Access (DAMA) mode, OTCIXS II operates in a half-duplex manner at a data rate of 1200 or 2400 bits per second (bps) in a permanently assigned timeslot of an ultrahigh frequency (UHF) DAMA channel to support subscriber communications. When functioning in Non-DAMA mode, OTCIXS II operates in a half-duplex manner at a data rate of 2400 or 4800 bps using a dedicated UHF channel. In either mode, the communications link implemented by OTCIXS II is referred to as an OTCIXS II radio frequency (rf) network. In the coverage area of an individual satellite multiple OTCIXS II rf networks may be operated independently.

a. Intranetwork Communications.

Intranetwork communications involve the exchange of messages between user systems that subscribe to a common OTCIXS II rf network. OTCIXS II will directly support intranetwork communications for the user system Tactical Data Processors (TDPs) shown in Table 1-1. OTCIXS II intranetwork connectivities are illustrated in Figure 1-1.

b. Internetwork Communications.

Internetwork communications involve the exchange of messages between a user system that subscribes to an OTCIXS II rf network and a user system:

1. Ashore
2. That subscribes to a different OTCIXS II rf network
3. That subscribes to a TADIXS or first generation OTCIXS rf network.

Table 1-1. OTCIXS II TDPs Communicating Intranetwork

OTCIXS II USER SYSTEM TDP	LOCATION
Tomahawk Weapons Control System (TWCS)	Surface Ship
Naval Communications Telecommunications Stations (NCTS)	Shore/Surface Ship
Naval Communications Telecommunications Station (NCTAMS)	Shore
Global Command & Control System - Maritime (GCCS-M)	Surface Ship
Mission Distribution System/Mission Data Display System (MDS/MDDS)	Shore
Joint Operational Tactical System (JOTS)	Surface Ship / Shore

OTCIXS II will operate in conjunction with TADIXS-A to support the internetwork communications requirements of the user system TDPs shown in Table 1-2. OTCIXS II internetwork connectivity is illustrated in Figure 1-2. Internetworking capabilities provided by TADIXS Gateway Facilities (TGFs), AN/USQ-64(V)9, implement the worldwide connectivity illustrated in Figure 1-3. TGFs are located at Naval Computer and Telecommunications Area Master Stations (NCTAMS) at Norfolk, Virginia (NCTAMS LANT), Wahiawa, Hawaii (NCTAMS EASTPAC), Finegayan, Guam (NCTAMS WESTPAC), and Bagnoli, Italy (NCTAMS MED), and at Naval Computer Telecommunications Station (NCTS) Stockton, California.

2. OTCIXS II Subscriber Equipment Suites.

Three OTCIXS II subscriber equipment suites need be implemented: surface ship,

submarine, and shore. These equipment suites are described in the following subparagraphs.

Table 1-2. TADIXS A/OTCIXS II TDPs Communicating Internetwork

TADIXS-A USER SYSTEM TDP	LOCATION
Naval Communications Telecommunications Station (NCTAMS)	Shore
Ocean Surveillance Information System (OSIS)	Shore
Mission Data Distribution System (MDDS)	Shore

a. Surface Ship.

The surface ship OTCIXS II configuration can function as the Network Control Station (NCS) or a subscriber unit of an OTCIXS II rf network (either DAMA or non-DAMA mode) and supports message exchange for the TWCS, FDDS, and teletypes.

Figure 1-4 illustrates the surface ship configuration. In the surface ship configuration, the

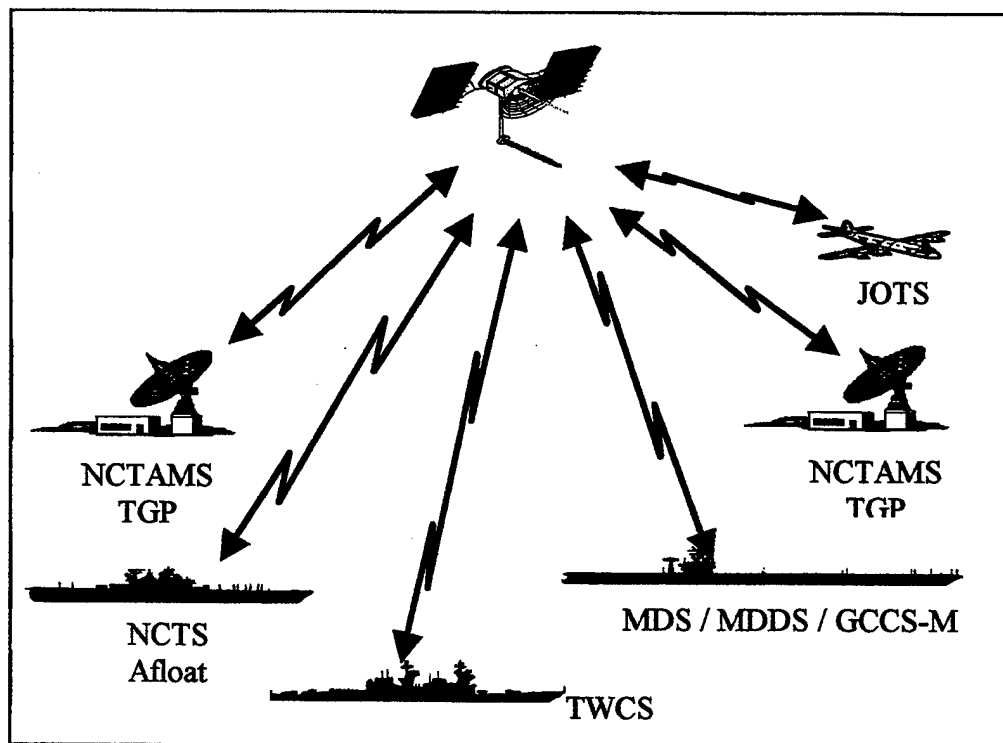

Figure 1-1. OTCIXS II Intranetwork Connectivity

OTCIXS II subscriber equipment suite consists of the following components:

(1). ON-143(V)6/USQ and/or ON-143(V)14/USQ Interconnecting Groups, including Control Indicator (CI), a human control interface (HCI) device, and the necessary software to enable it to function as an OTCIXS II Link Controller. The ON-143(V)6 of (V)14 hosting the OTCIXS II Link Controller also supports access to a TADIXS-A rf network. The TADIXS-A link protocols are capabilities outside the scope of this thesis.

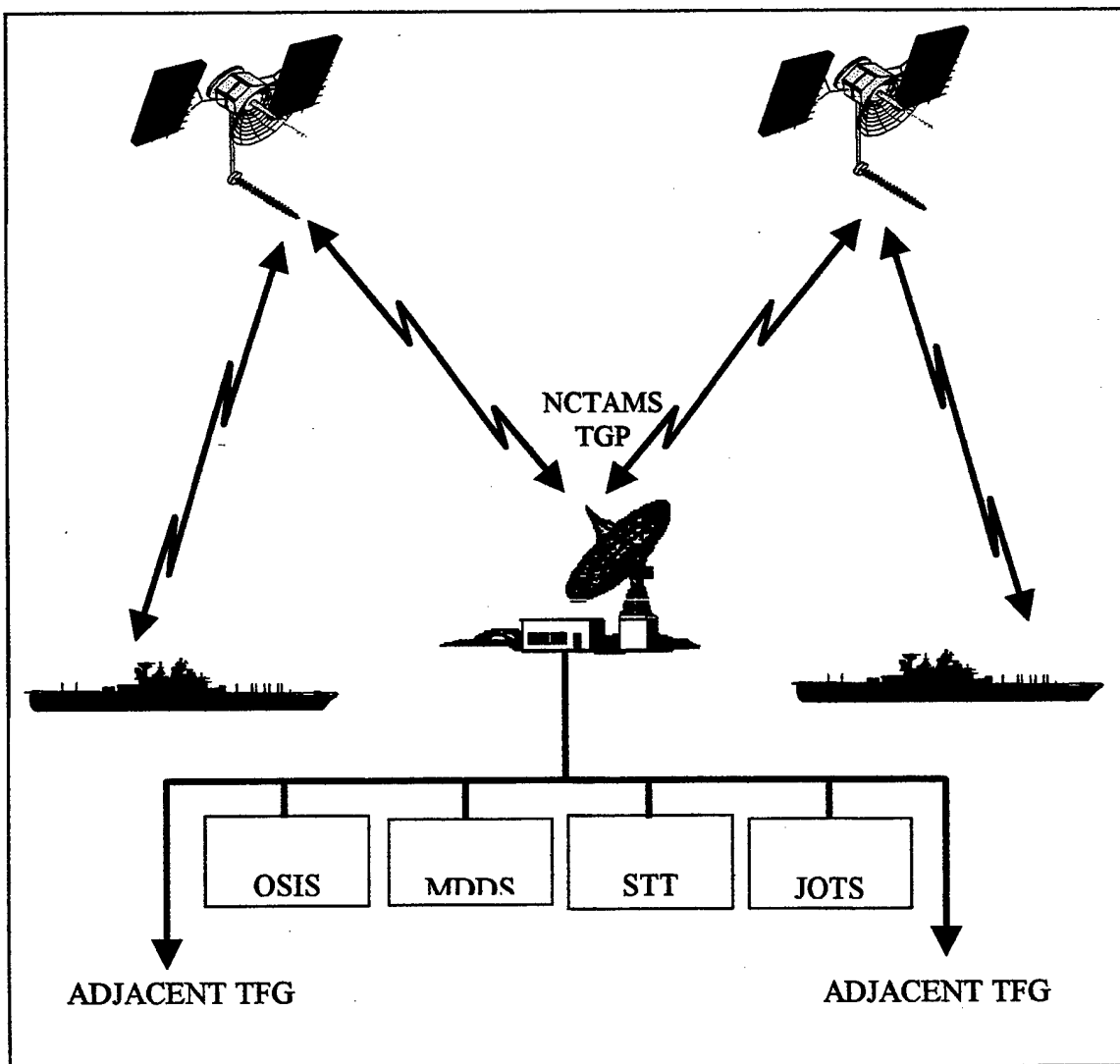

Figure 1-2. OTCIXS II Internetwork Connectivity

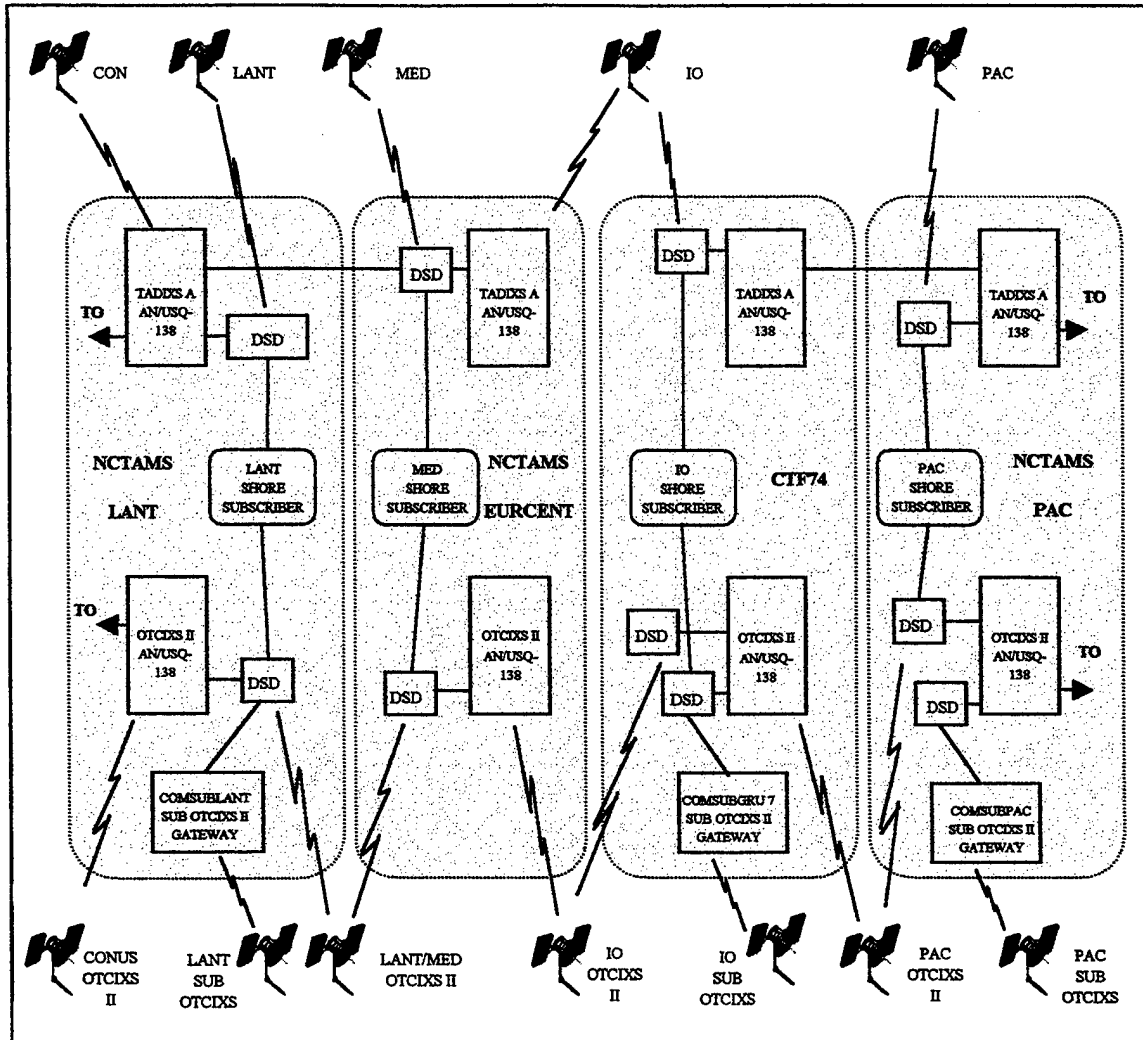

Figure 1-3. OTCIXS II Worldwide Connectivity by TADIXS

(2). KG-84A Cryptographic Unit.

(3). AN/UGC-136BX or AN/UGC-77 Teletype

b. Submarine.

The submarine OTCIXS II configuration functions as a subscriber unit of a Non-DAMA OTCIXS II rf network. The submarine OTCIXS II configuration supports message exchange for the CCS MK-1 / MK-2 and teletype. Figure 1-5 illustrates the submarine configuration. In the submarine configuration, the OTCIXS II subscriber

equipment suite consists of the following components:

- (1). ON-143(V)6/USQ or ON-143(V)14/USQ Interconnecting Group, including CI, with the necessary software to enable it to function as an OTCIXS II Link Controller. The ON-143(V)6 hosting the OTCIXS II Link Controller also supports access to a TADIXS-A or Submarine Satellite Information Exchange Subsystem (SSIXS) rf network. SSIXS capabilities are, however, outside the scope of this thesis.

- (2). KG-84A Cryptographic Unit.

- (3). AN/UGC-136AX or AN/UGC-77 Teletype.

c. Shore.

The shore OTCIXS II configuration functions as either NCS or a subscriber unit of the OTCIXS II DAMA or Non-DAMA rf network. It functions under the control of the TADIXS Gateway Processor (TGP) and supports the relay of subscriber messages between different rf networks or between user systems ashore and subscribers to the OTCIXS II rf network it accesses. Ashore TDPs supported by the OTCIXS II Link Controller are the TDDS, Shore Targeting Terminal (STT), Joint Operational Tactical System (JOTS), Global Command and Control System – Maritime (GCCS-M), Ocean Surveillance Information System (OSIS), OSIS Baseline Upgrade (OBU), and MDDS. Figure 1-6 illustrates the shore configuration.

In the shore configuration, the OTCIXS II subscriber equipment suite consists of the following components:

- (1). ON-143(V)6/USQ Interconnecting Group, including CI, with the necessary software also functions as the shore OTCIXS II Link Controller.

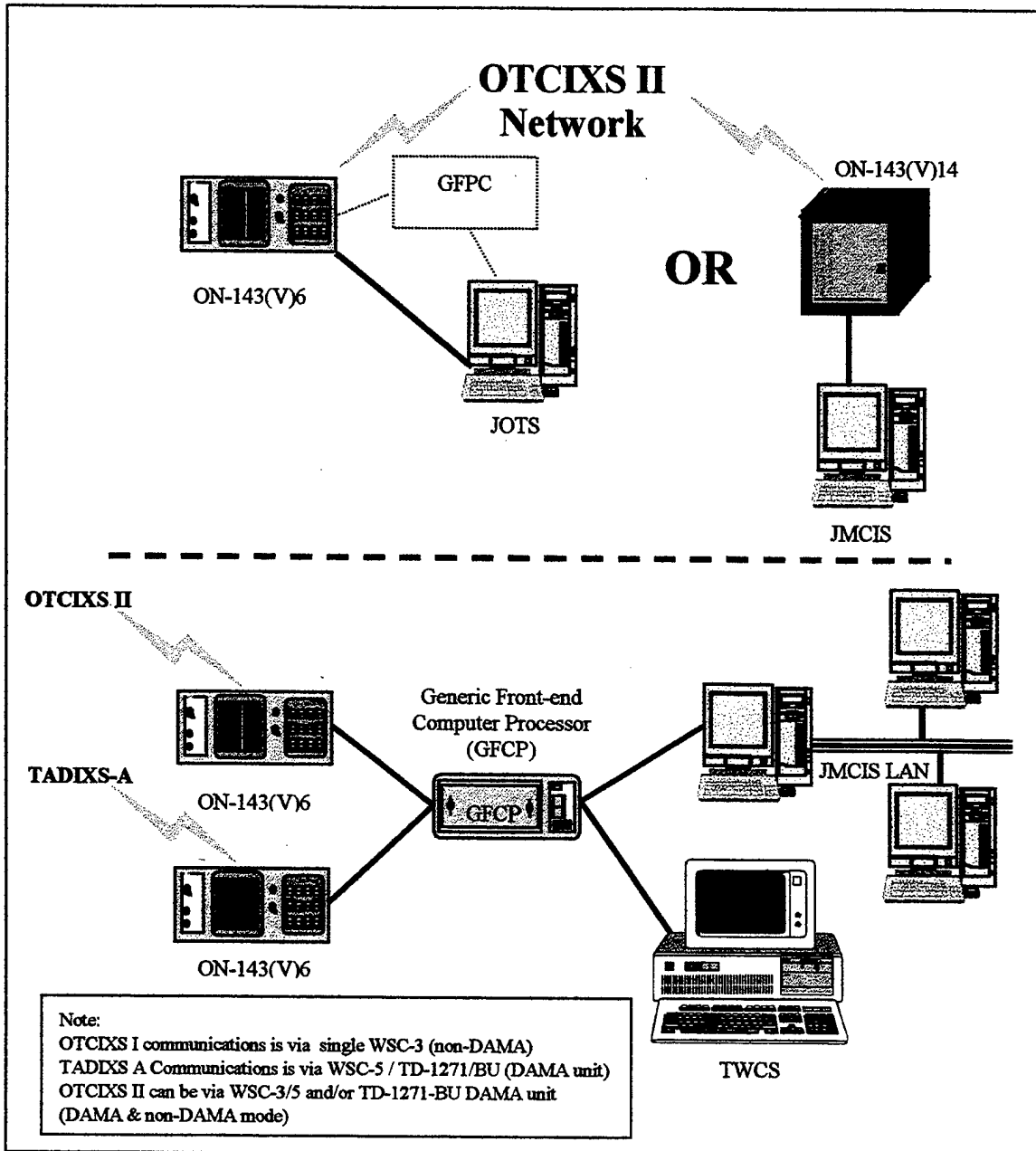

Figure 1-4. Surface Ship Configuration with OTCIXS II

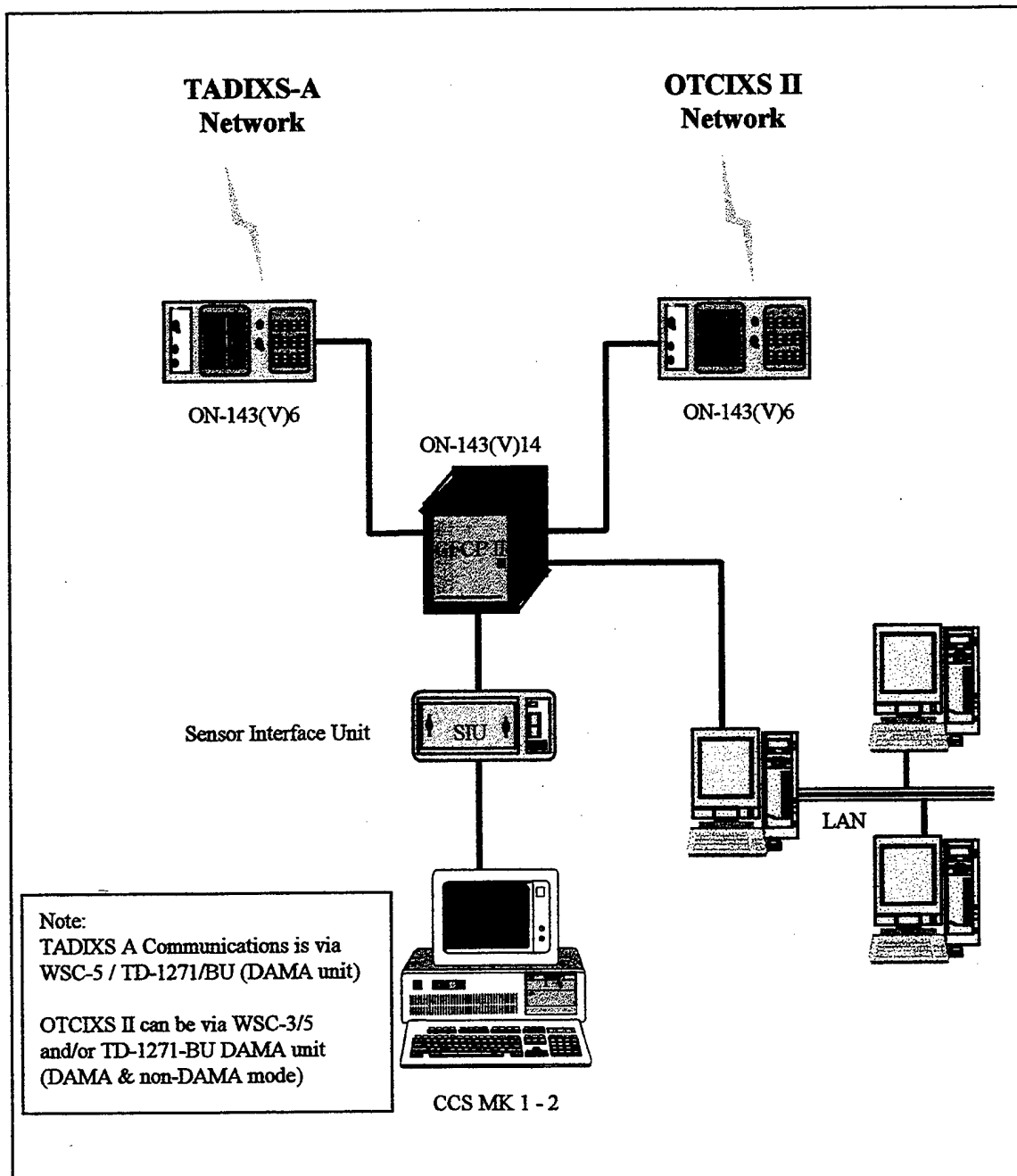

Figure 1-5. Submarine Configuration with OTCIXS II

(2). KG-84A Cryptographic Unit.

3. Subscriber Identification.

Each OTCIXS II subscriber is identified by a unique Subscriber Identification

(SID) number which may range from 0001 to 9999. The OTCIXS II accommodates the

following address types:

a. Discrete. A discrete SID is the unique number assigned to a specific surface ship, submarine, or shore facility.

b. Collective. A collective SID is the unique number assigned to a group of fleet units or commands. Provisions exist for two types of collective addresses. These are:

1. Organizational. Organizational collectives contain specific fleet platforms or shore commands. The composition of an organizational collective may change with time.

2. Regional. Regional collectives are associated with a specific satellite coverage area and effectively constitute an "... all subscribers in a geographic region ..." address.

a. Subscriber Data.

The OTCIXS II facilitates the timely exchange of subscriber messages. The OTCIXS II neither depends upon nor analyzes the information content of such messages but employs information contained in specially formatted "header" preambles which are attached to every message transferred over the satellite link. To support the internetwork routing of messages by TADIXS-A, OTCIXS II messages must conform to the requirements imposed by Volume I of the TADIXS Interface Design Specification (IDS).

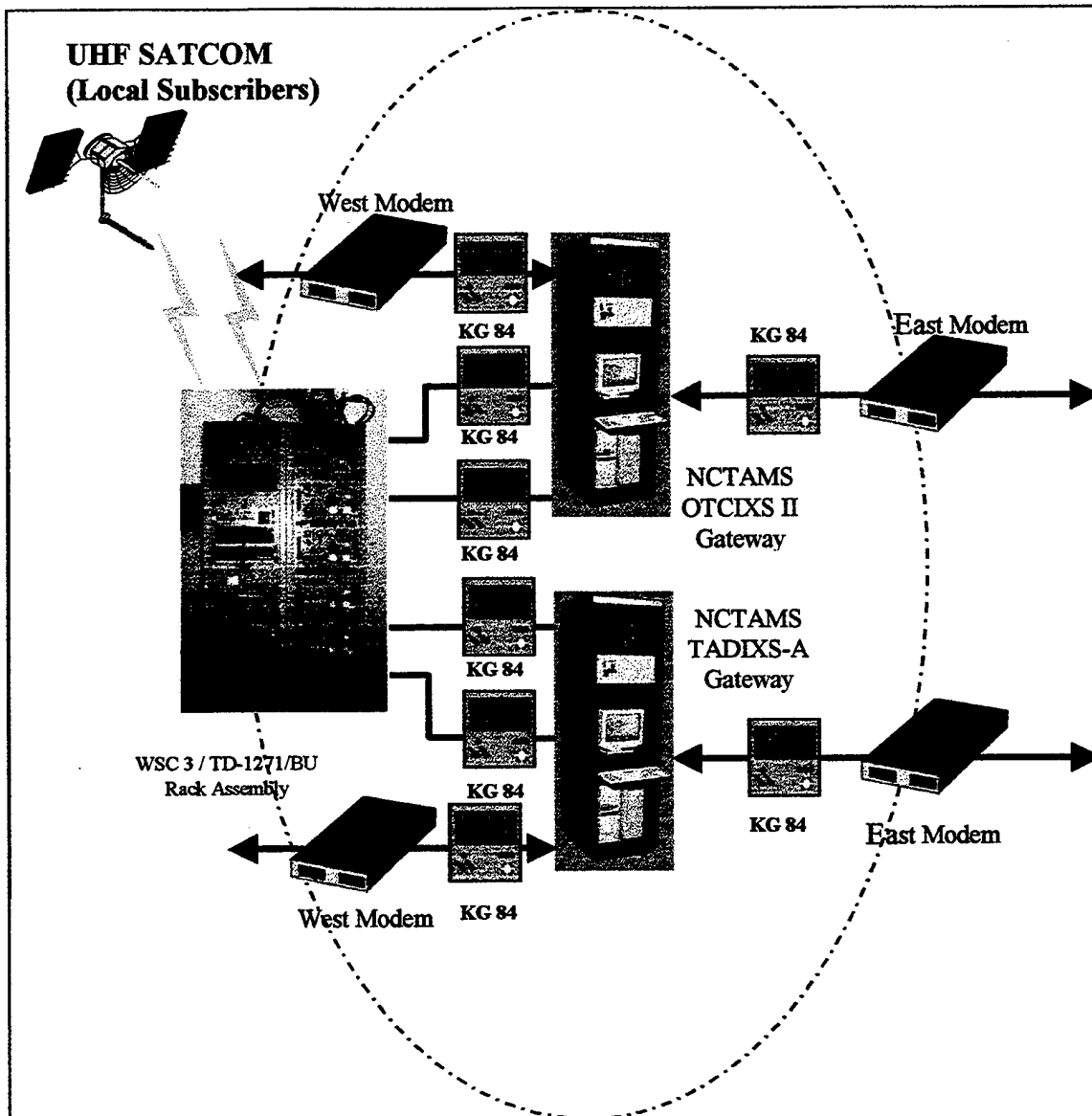

Figure 1-6. OTCIXS II Shore Gateway Configuration

b. Nonscheduled and Scheduled Broadcasts.

The OTCIXS II includes operating features needed to support both Nonscheduled and Scheduled broadcasts. Nonscheduled Broadcasts occur randomly and are independent of specific preplanned instants in real time. Nonscheduled broadcasts may be executed from any OTCIXS II configuration. Scheduled Broadcasts occur only at preplanned instants in real time. To define and execute a scheduled broadcast from a

surface ship configuration the OTCIXS II Link Controller receives all information required to implement that broadcast from the OTCIXS II operator via the attached CI. This information includes the number of times transmission is to occur and the times in each hour, expressed in quarter hours and minutes past the quarter hour, at which each transmission is to commence. To define and execute a scheduled broadcast from a shore configuration, the OTCIXS II Link Controller receives all information required to implement that broadcast from its interfaced TGP. Scheduled broadcasts cannot be defined or executed from a submarine configuration.

4. Message Identification.

Each subscriber to the OTCIXS II rf network assigns a 16-bit identifier to each message it transmits on that network. This identifier and the transmitting subscriber's SID provide unique message identification for message accountability.

a. Message Length.

OTCIXS II accommodates messages up to 10,103 bytes in length. Messages exceeding the maximum length must be divided by the originator, into multiple parts, each part not to exceed the maximum length. OTCIXS II treats each part of a multi-part message as a separate message. The user computer system is responsible for segmenting, reassembling, and sequencing the parts of a multi-part message.

b. Message Precedence.

The OTCIXS II recognizes Flash and Immediate precedence levels. Flash precedence messages always receive transmission priority over immediate precedence messages. Flash precedence messages always receive transmission priority over scheduled broadcast messages. Scheduled broadcast messages receive transmission priority over

nonscheduled Immediate precedence messages.

c. Network Control.

A subscriber designated as the Net Control Station (NCS) coordinates the use of the OTCIXS II network. All surface ship and shore sites will be capable of assuming the NCS function. The NCS receives, queues, and acknowledges receipt of subscriber access requests. Queued requests will be serviced in accordance with a first-come, first-served by precedence network server discipline. The NCS will assign service and assign transmission times to all Flash requests, then scheduled Immediate requests, and finally nonscheduled Immediate requests. Transmission of subscriber data occurs only when authorized by the NCS. Once a subscriber has been authorized by the NCS to transmit its message, the subscriber will commence message transmission. Once message transmission has commenced, the transmission will not be preempted by other message transmissions regardless of the precedence of the messages involved.

C. CONTENT DESCRIPTION.

The remainder of this document consists of the following sections and appendixes:

1. Section II, Applicable Documents, provides a list of documents applicable to the preparation of this document.
2. Section III, Interface Summary Cross-Index, provides a cross-index of signals transferred between OTCIXS II subscribers.
3. Section IV, Signal Definitions List, defines the usage and effect of each signal transferred between OTCIXS II subscribers.
4. Section V, Narrative Signal Flow Table, describes each interface signal as well as the interactions and interrelationships among the signals.

5. Section VI, Communication Controls and Conventions, defines and describes the communication control responsibilities and conventions for each of the OTCIXS II subscribers.

6. Section VII, Data Unit Descriptions, provides a detailed description of the data unit formats. This section will incorporate material specified by DI-E-2135. This interface type lends itself to the combined section and a clearer representation of the material is accomplished.

7. Appendix A, List of Acronyms and Abbreviations, provides a list of acronyms and their respective definitions.

8. Appendix B, Cyclic Redundancy Check Generation, lists and describes the algorithm being used to generate the Cyclic Redundancy Check.

9. Appendix C, OTCIXS II Simulation Results.

10. Appendix D, OTCIXS II Model Simulation Setup File Format.

11. Appendix E, Setup File Standard Values.

II. INTERFACE SUMMARY CROSS-INDEX

A. GENERAL.

This section provides a tabular index to sections IV (Signal Definition List), V (Narrative Signal Flow Table), and VII (Data Unit Descriptions) for each signal passed between members of an OTCIXS II network. It also lists and provides a cross-reference index (Table 2-1) to sections IV, V, and VII for the Physical layer signals employed by the OTCIXS II Link Controllers interfacing with:

1. KG-84A cryptographic device
2. TD-1271B/U DAMA multiplexer
3. AN/WSC-3/5 transceiver.

B. SIGNAL SUMMARY CROSS-INDEX - NET CONTROL STATION TO SUBSCRIBER.

Table 2-2 list the signals passed from the OTCIXS II Net Control Station (NCS) to the OTCIXS II subscribers and provides a cross-reference index to sections IV, V, and VII.

C. SIGNAL SUMMARY CROSS-INDEX - SUBSCRIBER TO NET CONTROL STATION.

Table 2-3 list the signals passed from the OTCIXS II subscribers to the OTCIXS II NCS and provides a cross-reference index to sections IV, V, and VII.

D. SIGNAL SUMMARY CROSS-INDEX - SUBSCRIBER TO SUBSCRIBER.

Table 2-4 list the signals passed between OTCIXS II subscribers and provides a cross-reference index to sections V, V, and VII.

Table 2-1. Physical Layer Signal Cross-Index

SIGNAL NAME	PAGE NUMBER INDEX TO		
	SIGNAL DEFINITION LIST	NARRATIVE SIGNAL FLOW TABLE	DATA UNIT/ MESSAGE DESCRIPTION
1. Channel Busy	24	45	--
2. Crypto Alarm Indicate	24	49	--
3. Crypto Alarm Reset	24	49	--
4. Crypto PREP	24	42 & 46	--
5. External Transmit Request	24	46	--
6. Keyline	25	42	--
7. Receive Data	25	45 & 48	--
8. Receive Data Black	25	45 & 48	--
9. Receive Data Red	25	45 & 48	--
10. Signal Acquired (SIGACQ)	25	48	--
11. Slot Time Mark (STM)	25	46	--
12. Transmit Data	26	44 & 47	--
13. Transmit Data Black	26	44 & 47	--
14. Transmit Data Red	26	44 & 47	--
15. Black Transmit Clock	26	--	--
16. Black Receive Clock	26	--	--
17. Black Receive/Transmit Clock	27	--	--
18. Red Gated Clock	27	--	--

Table 2-2. NCS to Subscriber Signal Cross-Index

SIGNAL NAME	PAGE NUMBER INDEX TO		
	SIGNAL DEFINITION LIST	NARRATIVE SIGNAL FLOW TABLE	DATA UNIT/ MESSAGE DESCRIPTION
1. Data Link Layer Packet a. Count b. Cyclic Redundant Check (CRC) c. End d. Information	27	--	135
2. Net Control Block (NCB) Transmission Unit (TU) a. Component Identification (CID) b. Copy c. Flash Slots d. Granted Subscriber ID (GSID) e. Hits f. Hours g. Immediate Slots h. Minutes i. Mode j. Net Control Station (NCS) Link Access Queue k. Net Control Station (NCS) Link Access Queue Size l. Net Control Station (NCS) SID m. RATS Type n. Scheduled Broadcast Status (SB STATUS) o. Seconds p. STU1 Acknowledge q. STU2 Acknowledge r. STU3 Acknowledge s. Time Checksum t. Transmit Count (XMIT CT) u. Window Size	28	50	117

Table 2-2. NCS to Subscriber Signal Cross-Index (cont.)

SIGNAL NAME	PAGE NUMBER INDEX TO		
	SIGNAL DEFINITION LIST	NARRATIVE SIGNAL FLOW TABLE	DATA UNIT/ MESSAGE DESCRIPTION
3. Network Message a. Block Check Sequence (BCS) b. Broadcast Sequence Number (BSN) a. c. Transport Message	31	--	134
4. Subscriber Transmission Unit (STU) a. Component Identification (CID) b. Copy c. Message Pointer Block d. Mode e. More f. Network Message g. Precedence (PREC) h. Reservation (RESV) i. Subscriber Identification (SID) j. Transmit Count (XMIT CT) k. Transmit Minute	32	57	128

Table 2-3. Subscriber to NCS Signal Cross-Index

SIGNAL NAME	PAGE NUMBER INDEX TO		
	SIGNAL DEFINITION LIST	NARRATIVE SIGNAL FLOW TABLE	DATA UNIT/ MESSAGE DESCRIPTION
1. Data Link Layer Packet a. Count b. Cyclic Redundancy Check (CRC) c. End d. Information	27	--	135
2. Network Message a. Block Check Sequence (BCS) b. Broadcast Sequence Number (BSN) c. Transport Message	34	--	134
3. Reservation Request TU (RRTU) a. Component Identification (CID) b. Copy c. Mode d. Retry Count e. Subscriber Identification (SID) f. Transmit Count (XMIT CT) g. Transmit Minute	34	54	125
4. Subscriber Transmission Unit (STU) a. Component Identification (CID) b. Copy c. Message Pointer Block d. Mode e. More f. Network Message g. Precedence (PREC) h. Reservation (RESV) i. Subscriber Identification (SID) j. Transmit Count (XMIT CT) k. Transmit Minute	35	57	128

Table 2-4. Subscriber to Subscriber Signal Cross-Index

SIGNAL NAME	PAGE NUMBER INDEX TO		
	SIGNAL DEFINITION LIST	NARRATIVE SIGNAL FLOW TABLE	DATA UNIT/ MESSAGE DESCRIPTION
1. Data Link Layer Packet a. Count b. Cyclic Redundancy Check (CRC) c. End d. Information	27	--	135
2. Network Message a. Block Check Sequence (BCS) b. Broadcast Sequence Number (BSN) c. Transport Message	37	--	134
3. Subscriber Transmission Unit (STU) a. Component Identification (CID) b. Copy c. Message Pointer Block d. Mode e. More f. Network Message g. Precedence (PREC) h. Reservation (RESV) i. Subscriber Identification (SID) j. Transmit Count (XMIT CT) k. Transmit Minute	37	57	128

III. SIGNAL DEFINITION LIST

A. GENERAL.

This section defines the physical interface signals used by the OTCIXS II Link Controller to control and monitor the KG-84A cryptographic unit, TD-1271B/U DAMA multiplexer, and AN/WSC-3/5 transceiver. It also defines the signals exchanged between members of an OTCIXS II network.

1. Protocol Layers.

The interface as described in this document consists of several protocol layers:

a. Physical Layer - The Physical Layer are the signals that the OTCIXS II software generates to control the OTCIXS II equipment or receives to monitor the OTCIXS II equipment. Signals discussed are the signals between the ON-143(V)6 or ON-143(V)14 (here after referred to as the OTCIXS II Link Controller) and:

1. KG-84A cryptographic device.
2. TD-1271B/U DAMA multiplexer.
3. AN/WSC-3/5 transceiver.

b. Data Link Layer - The Data Link Layer comprises the signals used to ensure an error-free transfer of information between OTCIXS II subscribers.

c. Network Layer - The Network Layer comprises the signals to control the allocation of the network resources among the OTCIXS II subscribers and the vehicle for transporting OTCIXS II subscriber to subscriber transactions.

2. General Definitions.

General definitions pertinent to the discussion of this interface are:

a. Broadcast Sequence Number (BSN) - the BSN is a 16-bit quantity assigned to a network message by the subscriber that originates an OTCIXS II transmission. BSNs shall be assigned sequentially so that missed messages can be detected by a gap in the BSNs received from a subscriber.

b. Transmission Unit (TU) - the TU is the entity that is transferred over the OTCIXS II network. All data items, network control and messages, shall be transmitted over the OTCIXS II network in TUs.

c. Net Control Station (NCS) - an OTCIXS II subscriber that controls the allocation of transmission time among the OTCIXS II network members.

d. Link Access Queue (LAQ) - a queue maintained by the NCS that identifies each OTCIXS II subscriber that has requested network transmission time. The queue shall be ordered first in, first out (FIFO) by precedence.

e. Net Cycle - an OTCIXS II net cycle is the time from the transmission of a Net Control Block (NCB) by the NCS to the next transmission of a NCB by the NCS. There are two types of net cycles: Idle and Busy. An idle cycle is a net cycle where no subscriber transmissions occur. A busy cycle is a net cycle where a subscriber transmission occurs. Each net cycle consists of time slots, as follows:

1. Control Time Slot (CTS) - provides the information to control the operation of the network. NCBs are transmitted in the CTS.

2. Random Access Time Slot (RATS) - provides the period for OTCIXS II subscribers to request transmission time. Reservation Request (RR) TUs (RRTUs), containing subscriber requests for net time, are transmitted in the RATS.

3. Subscriber Transmission Time Slot (STTS) - provides the period for

subscribers to transmit network messages. Subscriber TUs (STUs), containing network messages, are transmitted in the STTS.

f. Network Message - the entity transferred by the OTCIXS II protocol including sequencing to provide the mechanism for the detection of missed messages and a Block Check Sequence (BCS) used in error detection.

g. Request Slot (RS) - a period in a RATS where a subscriber is permitted to request net time from the NCS. There are two types of request slots: Immediate and Flash.

h. Subscriber Identification (SID) - the SID uniquely identifies a subscriber in the communication networks accessed by TADIXS (which includes OTCIXS II).

i. Transport Message - the subscriber-to-subscriber information entity, that is, formatted computer-to-computer data, teletype, and system control messages.

B. PHYSICAL LAYER SIGNAL DEFINITION LIST.

Physical Layer interface signals employed by the OTCIXS II Link Controller to control and monitor the KG-84A cryptographic unit, TD-1271B/U DAMA multiplexer, and the AN/WSC-3/5 transceiver are defined in Table 3-1.

C. DATA LINK LAYER SIGNAL DEFINITION LIST. The Data Link interface signals employed by the OTCIXS II Link Controller are defined in Table 3-2.

D. NETWORK LAYER SIGNAL DEFINITION LIST. The Network Layer interface signals employed by the OTCIXS II Link Controller are grouped into three categories:

a. Net Control Station (NCS) to Subscriber. Signals transferred from the OTCIXS II

NCS to OTCIXS II subscribers are listed and defined in Table 3-3.

b. Subscriber to Net Control Station. Signals transferred from OTCIXS II subscribers to the OTCIXS II NCS are listed and defined in Table 3-4.

c. Subscriber to Subscriber. Signals transferred between OTCIXS II subscribers are listed and defined in Table 3-5.

Fields containing critical data items in these data units are triply encoded. Triply encoded fields consist of the contents of the field itself, the contents of the field in the one's complement form, and the contents of the field Exclusive ORed with a binary pattern of alternating ones and zeros commensurate with the width of the field. A match of at least two of these fields will validate the contents of the field.

Table 3-1. Physical Layer Signal Definition List

SIGNAL	DEFINITION
1. Channel Busy	A signal from the AN/WSC-3/5 to the OTCIXS II Link Controller to indicate that a signal is present. It is received on Channel A, bit 4, of the Parallel Input/ Output (PIO) on the Black Dynamic Adaptive Receiver/ Transmitter (DART) in the OTCIXS II Link Controller. This signal is used only in Non-DAMA mode operations.
2. Crypto Alarm Indicate	A signal from the crypto to the OTCIXS II Link Controller to indicate that it is in the alarm state. It is received on channel B, bit 2, of the PIO on the Crypto DART in the OTCIXS II Link Controller. This signal is sent by the KG-84A as Red Alarm Indicate (RED-AI).
3. Crypto Alarm Reset	A signal from the OTCIXS II Link Controller to the crypto to clear the alarm state. It is sent on channel B, bit 6, of the PIO on the Crypto DART in the OTCIXS II Link Controller. This signal is received by the KG-84A as Remote Standby Red (RP-STBYR).
4. Crypto PREP	A signal from the OTCIXS II Link Controller to the crypto to put the crypto into the transmit mode and resynchronize it. It is sent on channel B, bit 7, of the PIO on the Crypto DART in the OTCIXS II Link Controller. This signal is received by the KG-84A as Synchronize Command Transmit (SYNC-CMD-TX)
5. External Transmit Request	Signal sent by the OTCIXS II Link Controller to the TD-1271B/U multiplexer to transmit a TU over the OTCIXS II network. It is sent on channel B, bit 6 and 7, of the PIO on Black Dart in the OTCIXS II Link Controller. This signal is used only in DAMA mode operations.

Table 3-1. Physical Layer Signal Definition List (cont.)

SIGNAL	DEFINITION
6. Keyline	Signal sent by the OTCIXS II Link Controller to the AN/WSC-3/5 transceiver to transmit a TU over the OTCIXS II network. It is sent on channel B, bit 6 and 7, of the PIO on the Black DART in the OTCIXS II Link Controller. This signal is used only in Non-DAMA mode operations. (In DAMA mode operations, the TD-1271B/U performs transceiver key functions).
7. Receive Data	Serial data received by the black side of the OTCIXS II Link Controller from the AN/WSC-3/5 (Non-DAMA mode operations) or TD-1271B/U (DAMA mode operations). The data is clocked by an internally generated clock that is synchronized to the external clock generated by the sending device.
8. Receive Data Black	Serial data sent to the crypto from the black side of the OTCIXS II Link Controller. Data is clocked by an internally generated clock that is synchronized to the external clock generated by the An/WSC-3/5 transceiver (Non-DAMA mode operation) or by the TD-1271B/U multiplexer (DAMA mode operations). This signal is received by the KG-84A as External Receive Cyphered Text (ERCT).
9. Receive Data Red	Serial data received from the crypto by the red side of the OTCIXS II Link Controller. Data is clocked by an internally generated clock that is synchronized to the external clock generated by the AN/WSC-3/5 transceiver (Non-DAMA mode operations) or by the TD-1271B/U multiplexer (DAMA mode operations). This signal is sent by the KG-84A as Receive Digital Plain Text (RX-DPT).
10. Signal Acquired (SIGACQ)	A signal from the TD-1271B/U multiplexer to the OTCIXS II Link Controller to indicate that a signal is present. It is received on channel A, bit 4 of the PIO on the Black DART in the OTCIXS II Link Controller. This signal is used only in DAMA mode operations.
11. Slot Time Mark (STM)	Signal received by the OTCIXS II Link Controller from the TD-1271B/U to provide DAMA timing. It is received on channel B, bit 4, of the PIO on both the Crypto and Black DART in the OTCIXS II Link Controller. Signal is received every 1.38667 seconds to provide synchronization with the DAMA timeslot. Signal is used only in DAMA mode operations.

Table 3-1. Physical Layer Signal Definition List (cont.)

SIGNAL	DEFINITION
12. Transmit Data	Serial data sent by the black side of the OTCIXS II Link Controller to the AN/WSC-3/5 (Non-DAMA mode operations) or the TD-1271B/U (DAMA mode operations). The data is clocked by an internally generated clock that is synchronized to the external clock generated by the receiving device.
13. Transmit Data Black	Serial data received by the black side of the OTCIXS II Link Controller from the crypto. The data is clocked by an internally generated clock that is synchronized to the external clock generated by the AN/WSC-3/5 transceiver (Non-DAMA mode operations) or by the TD-1271B/U multiplexer (DAMA mode operations). This signal is sent by the KG-84A as External Transmit Cyphered Text (ETCT)
14. Transmit Data Red	Serial data sent by the red side of the OTCIXS II Link Controller to the crypto. The data is clocked by an internally generated clock that is synchronized to the external clock generated by the AN/WSC-3/5 transceiver (Non-DAMA mode operations) or by the TD-1271B/U multiplexer (DAMA mode operations). This signal is received by the KG-84A as Transmit Digital Plain Text (TX-DPT).
15. Black Transmit Clock	This signal is generated by the AN/WSC-3 or TD-1271B/U. It provides transmit data bit interval timing information to the OTCIXS II Link Controller. It is connected to connector J1 pin # 70. The signal is then routed through the Radio Interface Board (RIB) to the Black DART board. The RIB card allows inversion and source selection of the transmit clock signal. During a transmit sequence, the Black DART software samples the transition of the transmit clock on PIO bit B2. It then phase-locks the CTC 0 timer to provide a stable Black Transmit Clock to the KG-84A.
16. Black Receive Clock	This signal is generated by the AN/WSC-3 or TD-1271B/U. It provides receive data bit interval timing information to the OTCIXS II Link Controller. It is connected to connector J1 pin # 76. The signal is then routed through RIB to the Black DART board. The RIB card allows inversion and source selection of the receive clock signal. During a receive sequence, the Black DART software samples the transition of the receive clock on PIO bit B3. It then phase-locks the CTC 0 timer to provide a stable Black Receive Clock to the KG-84A device.

Table 3-1. Physical Layer Signal Definition List (cont.)

SIGNAL	DEFINITION
17. Black Receive/Transmit Clock	This signal is generated by the CTC 0 on the Black DART in the OTCIXS II Link Controller. The signal is output from connector J9 pin # T on the rear connector panel. It provides receive and transmit bit interval timing for the KG-84A cryptographic units. It should be connected to the negative clock inputs on the KG-84A cryptographic device. This signal is a software phase-locked version of the Radio transmit and receive clocks.
18. Red Gated Clock	This signal is generated by the KG-84A cryptographic units. The KG-84A sends this signal on J3 pin 20, which is the receive clock's negative output. The KG-84A cryptos do not gate the receive clock during a receive run-up sequence.

Table 3-2. Data Link Layer Signal Definition List

SIGNAL	DEFINITION
1. Data Link Layer Packet	<p>The Data Link entity for a Network message. Provides error detection mechanism for messages.</p> <p>Indicates the number of bytes in the INFORMATION field.</p> <p>Provides an error detection code for the Data Link Packet as described in appendix B. Calculated over the COUNT, END, and INFORMATION fields of the packet.</p> <p>Identifies whether this is the last packet of a multipacket sequence.</p> <p>Part or all of a network message.</p>
a. Count	
b. Cyclic Redundancy check (CRC)	
c. End	
d. Information	

Table 3-3. NCS to Subscriber Signal Definition List

SIGNAL	OPERATION
<p>1. Net Control Block (NCB) Transmission Unit (TU)</p> <p>a. Component Identification (CID)</p> <p>b. Copy</p> <p>c. Flash Slots</p> <p>d. Granted Subscriber Identification (GSID)</p> <p>e. Hits</p> <p>f. Hours</p>	<p>A TU transmitted by the NCS to control the allocation of subscriber accesses to the OTCIXS II network. The NCB TU informs the OTCIXS II subscribers of the current net operating configuration.</p> <p>Identifies the TU as an NCB TU.</p> <p>Identifies the number of times, including this transmission, that this NCB has been transmitted in the current net cycle.</p> <p>Identifies the number of RSs in the current net cycle that are assigned to Flash message RRs. Within the RATS, these slots precede those assigned to Immediate message RRs. This field is ignored unless the RATS TYPE field indicates that a Normal RATS is present in the current net cycle.</p> <p>Identifies the OTCIXS II subscriber that has been assigned transmission time in the current net cycle.</p> <p>Indicates the minimum number of net cycles, within the window specified by the WINDOW SIZE field, in which a net member must receive at least one message for transmission in order to predict a network service requirement. Choices are 2,3,4, and 5 net cycles.</p> <p>Identifies the hours component of the current network time as maintained by the NCS.</p>

Table 3-3. NCS to Subscriber Signal Definition List (cont.)

SIGNAL	OPERATION
g. Immediate Slots	Identifies the number of RSs in the current net cycle that are assigned to Immediate message RRs. Within the RATS, these slots follow those assigned to Flash message RRs. This field is ignored unless the RATS TYPE field indicates that a Normal RATS is present in the current net cycle.
h. Minutes	Identifies the minutes component of the current network time as maintained by the NCS.
i. Mode	<p>Indicates the activity schedules for this net cycle. Possible activities are:</p> <ul style="list-style-type: none"> a. Nonscheduled transmission of Flash precedence STU b. Nonscheduled transmission of Immediate precedence STU c. Scheduled broadcast transmission of STU d. No STU transmission
j. Net Control Station (NCS) Link Access Queue (LAQ)	<p>Identifies pending requests for link time assignment for STU transmissions. Organized on a first-come, first-serve (FCFS) within precedence basis, the entries in this queue identify:</p> <ul style="list-style-type: none"> a. Requesting subscriber b. Type of service requested c. Number of transmissions requested d. Minute at which transmissions are to commence (scheduled broadcasts only).

Table 3-3. NCS to Subscriber Signal Definition List (cont.)

SIGNAL	OPERATION
k. Net Control Station (NCS) Link Access Queue (LAQ) Size	Indicates the number of entries in the NCS LAQ (i.e., the number of pending service requests by net subscribers).
l. Net Control Station (NCS) Subscriber Identification (SID)	Identifies the OTCIXS II subscriber that is performing the NCS function.
m. RATS Type	<p>Specifies the characteristics of the RATS supported in this net cycle are as followings:</p> <ul style="list-style-type: none"> a. A normal RATS is present in this cycle b. This is the first net cycle of an extended RATS c. This is an intermediate net cycle of an extended RATS d. This is the final net cycle of an extended RATS.
n. Scheduled Broadcast Status (SB STATUS)	Indicates if scheduled broadcasting is being performed in the current net cycle and, if not, whether scheduled broadcasting previously requested for the current net cycle has been preempted.
o. Seconds	Identifies the seconds component of the current network time as maintained by the NCS.
p. STU 1 Acknowledge	Provides an acknowledgment to the OTCIXS II subscriber that transmitted an STU one net cycle prior to the current one.
q. STU 2 Acknowledge	Provides an acknowledgment to the OTCIXS II subscriber that transmitted an STU two net cycles prior to the current one.
r. STU 3 Acknowledge	Provides an acknowledgment to the OTCIXS II subscriber that transmitted an STU three net cycles prior to the current one.

Table 3-3. NCS to Subscriber Signal Definition List (cont.)

SIGNAL	OPERATION
<p>s. Time Checksum</p> <p>t. Transmit Count (XMIT CT)</p> <p>u. Window Size</p>	<p>Indicates the checksum for the Hours, Minutes, and Seconds fields. Used to validate the time and to update the net time when validation is possible.</p> <p>Indicates the number of times the subscriber designated by the GSID field is to transmit its STU.</p> <p>Indicates the number of net cycles to be used by network service in predicting network service requirements. Choices are 12, 16, 20, and 24 net cycles.</p>
<p>2. Network Message</p> <p>a. Broadcast Sequence Number (BSN)</p> <p>b. Transport Message</p> <p>c. Block Check Sequence (BCS)</p>	<p>Provides the vehicle for transferring a Transport Message. Also provides for sequencing, to permit identification of missed messages, and error detection.</p> <p>Identifies the sequence number of the transfer. All transfers are sequentially numbered from a specific subscriber to permit receiving stations to recognize missed messages.</p> <p>The actual message at the Transport layer that is being transferred between OTCIXS II subscribers. The format of the Transport Layer Message is as defined in the TADIXS IDS, Volume I.</p> <p>Provides an error detection code for the Transport Layer message as described in Appendix B. Calculated over all bytes of the Transport Message field.</p>

Table 3-3. NCS to Subscriber Signal Definition List (cont.)

SIGNAL	OPERATION
3. Subscriber Transmission Unit (STU)	Provides the transmission entity for the Transport layer entities (e.g., formatted computer-to-computer data and teletype messages).
a. Component Identification (CID)	Identifies the TU as an STU.
b. Copy	Identifies the number of times, including this transmission, that this STU has been transmitted in the current net cycle.
c. Message Pointer Block	Identifies how many network messages are present in the STU and, for each such message, a pointer to the start of the message in the STU. Also contains a Pointer Check Sequence (PCS), calculated in accordance with Appendix B, to ensure the validity of the message pointers.
d. Mode	<p>When the Reservation (RESV) field indicates that this STU contains a piggybacked service request, this field identifies the type of request being made. Possible service requests are:</p> <ul style="list-style-type: none"> a. Nonscheduled transmission of Flash precedence STU required b. Nonscheduled transmission of Immediate precedence STU required c. Scheduled broadcast transmission of STU required.
e. More	Indicates if additional service is required for STU transmission on the current broadcast schedule (i.e., the current scheduled broadcast cannot be completed in a single STU).
f. Network Message	Contains a Transport Message and a BCS. Also identifies the BSN for the transaction.
g. Precedence (PREC)	Identifies the precedence level of the STU as either Immediate or Flash.

Table 3-3. NCS to Subscriber Signal Definition List (cont.)

SIGNAL	OPERATION
h. Reservation (RESV)	Indicates whether this STU contains a piggybacked service request.
i. Subscriber Identification (SID)	Identifies the OTCIXS II subscriber that originated the STU transmission.
j. Transmit Count (XMIT CT)	When the RESV field indicates that a piggybacked RR is present, this field indicates the number of times the STU referenced by that request is to be transmitted.
k. Transmit Minute	When the RESV field indicates that a piggybacked service request for a scheduled broadcast is present, this field indicates the minute, within the hour, at which that broadcast is to occur.

Table 3-4. Subscriber to NCS Signal Definition List

SIGNAL	DEFINITION
<p>1. Network Message</p> <p>a. Broadcast Sequence Number (BSN)</p> <p>b. Transport Message</p> <p>c. Block Check Sequence (BCS)</p>	<p>Provides the vehicle for transferring a Transfer Message. Also provides for sequencing, to permit identification of missed messages, and error detection.</p> <p>Identifies the sequence number of the transfer. All transfers are sequentially numbered from a specific subscriber to permit receiving stations to recognize missed messages.</p> <p>The actual message at the Transport layer that is being transferred between OTCIXS II subscribers. The format of the Transport Layer Message is as defined in the TADIXS IDS, Volume I.</p> <p>Provides an error detection code for the Transport Layer message as described in Appendix b. Calculated over all bytes of the Transport Message field.</p>
<p>2. Reservation Request Transmission Unit (RRTU)</p> <p>a. Component Identification (CID)</p> <p>b. Copy</p> <p>c. Mode (BCS)</p>	<p>A TU transmitted in an RS to request service; that is, time on the OTCIXS II network to transmit a STU. Notifies the NCS that a net subscriber requires net service.</p> <p>Identifies the TU as an RRTU.</p> <p>Identifies the number of times, including this transmission, that this RRTU has been transmitted in the current net cycle.</p> <p>Identifies the type of request being made. Possible service requests are:</p> <ul style="list-style-type: none"> a. Nonscheduled transmission of Flash precedence STU b. Nonscheduled transmission of Immediate precedence STU c. Scheduled broadcast transmission of STU

Table 3-4. Subscriber to NCS Signal Definition List (cont.)

SIGNAL	DEFINITION
<p>d. Retry Count</p> <p>e. Subscriber Identification (SID)</p> <p>f. Transmit Count (XMIT CT)</p> <p>g. Transmit Minute</p>	<p>Indicates the number of times a subscriber has attempted net entry prior to acknowledgment by the NCS in the NCB.</p> <p>Identifies the OTCIXS II subscriber that is making the request.</p> <p>Indicates the number of times the subscriber desires to transmit its STU.</p> <p>When the MODE field indicates that a scheduled broadcast is required, this field identifies the minute, within the hour, at which that broadcast is to occur.</p>
<p>3. Subscriber Transmission Unit (STU)</p> <p>a. Component Identification</p> <p>b. Copy</p> <p>c. Message Pointer Block</p> <p>d. Mode</p>	<p>Provides the transmission entity for the Transport layer entities (e.g., formatted computer-to-computer data and teletype messages).</p> <p>Identifies the TU as a STU</p> <p>Identifies the number of times, including this transmission, that this STU has been transmitted in the current net cycle.</p> <p>Identifies how many network messages are present in the STU and, for each such message, a pointer to the start of the message in the STU. Also contains a Pointer Check Sequence (PCS), calculated in accordance with Appendix B, to ensure the validity of the message pointer.</p> <p>When the RESV field indicates that this STU contains a piggybacked service request, this field identifies the type of request being made. Possible service requests are:</p>

Table 3-4. Subscriber to NCS Signal Definition List (cont.)

SIGNAL	DEFINITION
d. Mode (cont.)	<ul style="list-style-type: none"> a. Nonscheduled transmission of Flash precedence STU required b. Nonscheduled transmission of Immediate precedence STU required c. Scheduled broadcast transmission of STU required d. Nonscheduled transmission of Immediate precedence STU predicted.
e. More	<p>Indicates if additional service is required for STU transmission on the current broadcast schedule (i.e., the current scheduled broadcast cannot be completed in a single STU).</p>
f. Network Message	<p>Contains a Transport Message and a BCS. Also identifies the BSN for the transaction.</p>
g. Precedence (PREC)	<p>Identifies the precedence level of the STU as either Immediate or Flash.</p>
h. Reservation (RESV)	<p>Indicates whether this STU contains a piggybacked service request.</p>
i. Subscriber Identification (SID)	<p>Identifies the OTCIXS II subscriber that originated the STU transmission</p>
j. Transmit Count (XMIT CT)	<p>When the RESV field indicates that a piggybacked RR is present, this field indicates the number of times the STU referenced by that request is to be transmitted.</p>
k. Transmit Minute	<p>When the RESV field indicates that a piggybacked service request for a scheduled broadcast is present, this field indicates the minute, within the hour, at which that broadcast is to occur.</p>

Table 3-5. Subscriber to Subscriber Signal Definition List

SIGNAL	DEFINITION
<p>1. Network message</p> <p>a. Broadcast Sequence Number (BSN)</p> <p>b. Transport Message</p> <p>c. Block Check Sequence (BCS)</p>	<p>Provides the vehicle for transferring a Transport Message. Also provides for sequencing, to permit identification of missed messages, and error detection.</p> <p>Identifies the sequence number of the transfer. All transfers are sequentially numbered from a specific subscriber to permit receiving stations to recognize missed messages.</p> <p>The actual message at the Transport layer that is being transferred between OTCIXS II subscribers. The format of the Transport Layer Message is as defined in the TADIXS IDS, Volume I.</p> <p>Provides an error detection code for the Transport Layer message as described in Appendix B. Calculated over all bytes of the Transport Message field.</p>
<p>2. Subscriber Transmission Unit (STU)</p> <p>a. Component Identification (CID)</p> <p>b. Copy</p> <p>c. Message Pointer Block</p>	<p>Provides the transmission entity for the Transport Layer entities (e.g., formatted computer-to-computer data and teletype messages).</p> <p>Identifies the TU as an STU.</p> <p>Identifies the number of times, including this transmission; that this STU has been transmitted in the current net cycle.</p> <p>Identifies how many network messages are present in the STU and, for each such message, a pointer to the start of the message in the STU. Also contains a PCS, calculated in accordance with Appendix B, to ensure the validity of the message pointers.</p>

Table 3-5. Subscriber to Subscriber Signal Definition List (cont.)

SIGNAL	DEFINITION
d. Mode	<p>When the RSV field indicates that this STU contains a piggybacked service request, this field identifies the type of request being made. Possible service requests are:</p> <ul style="list-style-type: none"> a. Nonscheduled transmission of Flash precedence STU required b. Nonscheduled transmission of Immediate precedence STU required c. Scheduled broadcast transmission of STU required d. Nonscheduled transmission of Immediate precedence STU predicted.
e. More	<p>This field is interpreted by NCS. It is not interpreted by the receiving subscriber.</p> <p>Indicates if additional service is required for STU transmission on the current broadcast schedule (i.e., the current scheduled broadcast cannot be completed in a single STU).</p> <p>This field is interpreted by NCS. It is not interpreted by the receiving subscriber.</p>
f. Network Message	<p>Contains a transport message and a BCS. Also identifies the BSN for the transaction.</p>
g. Precedence (PREC)	<p>Identifies the precedence level of the STU as either Immediate or Flash.</p>
h. Reservation (RESV)	<p>Indicates whether this STU contains a piggybacked service request.</p>
i. Subscriber Identification (SID)	<p>This field is interpreted by NCS. It is not interpreted by the receiving subscriber.</p>

Table 3-5. Subscriber to Subscriber Signal Definition List (cont.)

SIGNAL	DEFINITION
j. Transmit Count (XMIT CT)	<p>Identifies the OTCIXS II subscriber that originated the STU transmission.</p> <p>When the RESV field indicates that a piggybacked RR is present, this field indicates the number of times the STU referenced by that request is to be transmitted.</p>
k. Transmit Minute	<p>This field is interpreted by NCS. It is not interpreted by the receiving subscriber.</p> <p>When the RESV field indicates that a piggybacked service request for a scheduled broadcast is present, this field indicates the minute, within the hour, at which that broadcast is to occur.</p> <p>This field is interpreted by NCS. It is not interpreted by the receiving subscriber.</p>

THIS PAGE INTENTIONALLY LEFT BLANK

IV. NARRATIVE SIGNAL FLOW TABLE

A. GENERAL.

The section provides a narrative tabulation by logical signal groupings of signal flow between OTCIXS II subscribers. Also included are the Physical Layer signals used by the OTCIXS II Link Controllers (LC) to control and monitor the:

1. KG-84A cryptographic device
2. TD-1271B/U DAMA multiplexer
3. AN/WSC-3/5 transceiver.

This tabulation provides a description of the signal, flow direction, initiation, response and amplifying remarks.

B. SIGNAL FLOW TABLES.

1. Physical Layer.

Table 4-1 presents the signal flow table for the Physical Layer. The narrative signal flow for the Physical Layer is presented in the following logical groupings:

- a. Non-DAMA Mode Data Transmission
- b. Non-DAMA Mode Data Reception
- c. DAMA Mode Data Transmission
- d. DAMA Mode Data Reception
- e. Crypto Error Handling.

2. Data Link and Network Layer.

As described in section 4, the Data Link Layer is closely tied to the Network Layer,

therefore these layers are presented in a single signal flow table. Table 4-2 presents the signal flow table for the Data Link and Network Layers. A single narrative signal flow, Message Transfer, for these layers is presented.

Table 4-1. Physical Layer Signal Flow

SIGNAL	FROM/TO	INITIATION	RESPONSE	REMARKS
1. Non-DAMA Mode Data Transmission a. Keyline	OTCIXS II LC to AN/WSC-3/5 transceiver	Keyline is asserted when transmission of a TU on the satellite link is required.	The AN/WSC-3/5 transceiver generates a modem preamble which is 60 ms in duration after a 40 ms power up delay and prepares to receive Transmit Data for transmission.	Keyline is removed immediately following the completion of TU transmission. For repeated copies of a TU transmission (i.e., multiple copies of a TU in a single net cycle), Keyline will be reasserted for each copy transmitted.
b. Crypto PREP	OTCIXS II LC to crypto	Crypto PREP will be asserted immediately following keyline assertion.	The KG-84A executes an alarm check sequence and transmits a crypto pre-amble which will be received by other KG-84A cryptos on the OTCIXS II network.	Crypto PREP is received by the KG-84A as SYNC-CMD-TX. The duration of the synchronization pattern generated by the KG-84A will be approximately 364 bit times when the baseband data rate is 2400 bps and 381 bit times when it is 4800 bps. Receiving cryptos

SIGNAL	FROM/TO	INITIATION	RESPONSE	REMARKS
1. Non-DAMA Mode Data Transmission a. Keyline	OTCIXS II LC to AN/WSC-3/5 transceiver	Keyline is asserted when transmission of a TU on the satellite link is required.	The AN/WSC-3/5 transceiver generates a modem preamble which is 60 ms in duration after a 40 ms power up delay and prepares to receive Transmit Data for transmission.	Keyline is removed immediately following the completion of TU transmission. For repeated copies of a TU transmission (i.e., multiple copies of a TU in a single net cycle), Keyline will be reasserted for each copy transmitted.
				of the same type as the transmitting crypto will acquire synchronization with the transmitting crypto. Assertion of Crypto PREP will precede each TU transmission.

Table 4-1. Physical Layer Signal Flow (cont.)

SIGNAL	FROM/TO	INITIATION	RESPONSE	REMARKS
<p>Non-DAMA Mode Data Transmission (cont.)</p> <p>c. Transmit Data Red</p>	OTCIXS II LC to crypto	After a crypto-type dependent delay following assertion of Crypto PREP (to allow for transmission of the crypto preamble). For the KG-84A this delay is dependent on the baseband data rate employed. For 2400 bps the delay must be at least 364 bit times. For 4800 bps it must be at least 381 bit times.	Crypto performs encryption of the received serial data and sends the resulting serial data stream to the black side of the OTCIXS II LC as Transmit Data Black.	Transmit Data Red is received by the KG-84A from the red side of the OTCIXS II LC as TX-DPT. For the KG-84A, the first two bytes of Transmit Data Red must be the BISYNC code to permit data synchronization by the receiving processor.
d. Transmit Data Black	Crypto to OTCIXS II LC	Following receipt of serial data (Transmit Data Red) by the crypto and encryption of that data.	<p>Transmit Data Black is received from the crypto by the black side of the OTCIXS II LC.</p> <p>Received serial data is immediately forwarded as Transmit Data to the AN/WSC-3/5 transceiver for transmission.</p>	Transmit Data Black is sent by the KG-84A as ETCT.
e. Transmit Data	OTCIXS II LC to AN/WSC-3/5 transceiver	Following receipt of serial data (Transmit Data Black) from the Crypto.	Received serial data is transmitted on the OTCIXS II rf channel.	Transmit data is received by the transceiver from the black side of the OTCIXS II LC.

Table 4-1. Physical Layer Signal Flow (cont.)

SIGNAL	FROM/TO	INITIATION	RESPONSE	REMARKS
2. Non-DAMA Mode Data Reception				
a. Channel Busy	AN/WSC-3/5 transceiver to OTCIXS II LC	Presence of a receive signal at the AN/WSC-3/5 transceiver.	Prepare to receive the crypto preamble and transmitted TU.	
b. Receive Data	AN/WSC-3/5 transceiver to OTCIXS II LC	Presence of a receive signal.	Received serial data is forwarded to the crypto as Receive Data Black. If crypto preamble is detected, prepare to receive transmitted TU.	Receive Data is received from the AN/WSC-3/5 transceiver by the black side of the OTCIXS II LC.
c. Receive Data Black	OTCIXS II LC to crypto	Following receipt of Receive Data from the AN/WSC-3/5 transceiver.	Crypto performs decryption of the received serial data and sends the resulting serial data stream to the red side of the OTCIXS II LC as Receive Data Red.	Receive Data Black is received by the KG-84A from the black side of the OTCIXS II LC as ERCT.
d. Receive Data Red	Crypto to OTCIXS II LC	Following receipt of serial data (Receive Data Black) by the crypto and decryption of that data.	Receive Data Red is received from the crypto by the red side of the OTCIXS II LC and forwarded to the Data Link Layer for processing.	Receive Data Red is sent by the KG-84A as RX-DPT. For the KG-84A, the detection of a BISYNC code will signal the commencement of TU reception. The BISYNC code indicates that modem, crypto, and data synchronization has been achieved.

Table 4-1. Physical Layer Signal Flow (cont.)

SIGNAL	FROM/TO	INITIATION	RESPONSE	REMARKS
<p>3. DAMA Mode Data Transmission</p> <p>a. Slot Time Mark (STM)</p>	TD-1271 B/U to OTCIXS II LC	Generated by the TD-1271B every 1.38667 seconds to provide synchronization with the DAMA frame.		<p>The transmission of the crypto preamble, which initiates TU transmission, is synchronized with receipt of STM.</p> <p>Failure to receive STM in a 2-second interval constitutes a link failure.</p>
b. External Transmit Request	OTCIXS II LC to TD-1271 B/U	External Transmit Request is asserted when transmission of a TU on the satellite link is required.	The TD-1271 B/U prepares to receive Transmit Data for transmission.	External Transmit Request must be asserted only once for repeated copies of a TU transmission (i.e., multiple copies of a TU in a single net cycle).
c. Crypto PREP	OTCIXS II LC to KG-84A crypto	Crypto PREP will be asserted immediately following External Transmit Request assertion.	The KG-84A executes an alarm check sequence and transmits a crypto preamble which will be received by other KG-84A cryptos on the OTCIXS II network.	<p>Crypto PREP is received by the KG-84A as SYNC-CMD-TX.</p> <p>Each KG-84A receiving the crypto preamble will acquire synchronization with the transmitting KG-84A.</p> <p>The duration of the synchronization pattern generated by the KG-84A will be at least 347 bit times when the baseband data rate is 1200 bps and 364 bit times when it is 2400 bps.</p>

Table 4-1. Physical Layer Signal Flow (cont.)

SIGNAL	FROM/TO	INITIATION	RESPONSE	REMARKS
DAMA Mode Data Transmission (cont.) c. Crypto PREP (cont.)				Assertion of Crypto PREP will precede each TU transmission on the satellite link.
d. Transmit Data Red	OTCIXS II LC to KG-84A crypto	After a baseband data rate dependent delay following assertion of Crypto PREP (to allow for transmission of the crypto preamble). For 1200 bps the delay must be at least 347 bit times. For 2400 bps it must be at least 364 bit times.	The KG-84A performs encryption of the received serial data and sends the resulting serial data stream to the black side of the OTCIXS II LC as Transmit Data Black.	Transmit Data Red is received by the KG-84A from the red side of the OTCIXS II LC as TX-DPT. The first two bytes of Transmit Data Red must be the BISYNC code to permit data synchronization by the receiving processor.
e. Transmit Data Black	KG-84A crypto to OTCIXS II LC	Following receipt of serial data (Transmit Data Red) by the KG-84A and encryption of that data.	Transmit Data Black is received from the crypto by the black side of the OTCIXS II LC.	Transmit Data Black is sent by the KG-84A as ETCT.
f. Transmit Data	OTCIXS II LC to TD-1271 B/U	Following receipt of encrypted serial data (Transmit Data Black) from the crypto.	Received serial data is immediately forwarded as Transmit Data to the TD-1271 B/U. Received serial data is transmitted in the DAMA timeslot.	Transmit data is received by the TD-1271 B/U from the black side of the OTCIXS II LC.

Table 4-1. Physical Layer Signal Flow (cont.)

SIGNAL	FROM/TO	INITIATION	RESPONSE	REMARKS
4. DAMA Mode Data Reception				
a. Signal Acquired (SIGACQ)	TD-1271B/U to OTCIXS II LC	Presence of a receive signal at the TD-1271B/U multiplexer.	Prepare to receive the crypto preamble and transmitted TU.	
b. Receive Data	TD-1271 B/U to OTCIXS II LC	Presence of a receive signal.	Received serial data is forwarded to the KG-84A as Receive Data Black. If crypto preamble is detected, prepare to receive transmitted TU.	Receive Data is received from the TD-1271 B/U by the black side of the OTCIXS II LC.
c. Receive Data Black	OTCIXS II LC to KG-84A crypto	Following receipt of Receive Data from the TD-1271B/U.	The KG-84A performs decryption of the received serial data and sends the resulting serial data stream to the red side of the OTCIXS II LC as Receive Data Red.	Receive Data Black is received by the KG-84A from the black side of the OTCIXS II LC as ERCT.
d. Receive Data Red	Crypto to OTCIXS II LC	Following receipt of serial data (Receive Data Black) by the crypto and decryption of that data.	Receive Data Red is received from the crypto by the red side of the OTCIXS II LC and forwarded to the Data Link Layer for processing.	Receive Data Red is sent by the KG-84A as RX-DPT. The detection of a BISYNC code will signal the commencement of TU reception. The BISYNC code indicates that modem, crypto, and data synchronization has been achieved.

Table 4-1. Physical Layer Signal Flow (cont.)

SIGNAL	FROM/TO	INITIATION	RESPONSE	REMARKS
<p>5. Crypto Error Handling</p> <p>a. Crypto Alarm Indicate</p>	Crypto to OTCIXS II LC	By the crypto to indicate that it is in an alarm state.	<p>The OTCIXS II LC shall attempt to clear the alarm state by signaling Crypto Alarm Reset.</p> <p>If the crypto still indicates an alarm condition after three alarm reset attempts, the OTCIXS II LC shall consider the interface to be inoperable.</p>	Crypto Alarm Indicate is sent by the KG-84A as RED-AI.
b. Crypto Alarm Reset	OTCIXS II LC to crypto	By OTCIXS II LC to clear the alarm state of its crypto indicated by reception of Crypto Alarm Indicate.	The crypto will attempt to clear the Crypto Alarm Indicate signal and take itself out of the alarm state.	<p>Crypto Alarm Reset is received by the KG-84A as RP-STBYR.</p> <p>The OTCIXS II LC will continue to attempt to clear the alarm state until the Crypto Alarm Indicate signal is removed.</p>

Table 4-2. Data Link and Network Layer Signal Flow

SIGNAL	FROM/TO	INITIATION	RESPONSE	REMARKS
<p>1. Message Transfer</p> <p>a. Net Control Block (NCB) Transmission Unit (TU)</p>	<p>Net Control Station (NCS) to Subscriber</p>	<p>Sent at the following times to mark the beginning of an OTCIXS II net cycle:</p> <p>a. Upon completion of NCS initialization processing.</p> <p>b. Upon completion of an idle cycle</p> <p>c. Upon completion of a busy cycle</p>	<p>The packet CRC of the Data Link Layer packet containing the NCB shall be validated by calculating the packet CRC and comparing it with the CRC value present in that packet. If validation is not achieved, the packet shall be marked as bad and replaced with a packet received in a repeat transmission of the NCB if such a transmission is received. After all repeats of the NCB have been received or an error-free NCB is received, processing of the NCB shall continue as follows:</p>	<p>Processing of the NCB's triply redundant fields or of the HOURS, MINUTES, and SECONDS fields (which are validated against the TIME CHECKSUM field) shall be performed even when the packet CRC cannot be validated.</p>
<p>a. Net Control Block (NCB) Transmission Unit (TU) (cont.)</p>	<p>Net Control Station (NCS) to Subscribers</p>		<p>1. Validate the NCB triply redundant fields:</p> <p>a. If validation of the CID field cannot be achieved, the NCB shall be discarded. In that case, wait for transmission of another NCB TU.</p> <p>b. If validation of the NCS SID field is achieved, perform the following operations:</p>	<p>Validation of the triply redundant fields requires obtaining at least a two out of three match.</p> <p>The received TU cannot be identified as an NCB TU if the CID value is invalid.</p> <p>Processing of the NCB shall continue even when the NCS SID field cannot be validated.</p>

Table 4-2. Data Link and Network Layer Signal Flow (cont.)

SIGNAL	FROM/TO	INITIATION	RESPONSE	REMARKS
Message Transfer (cont.)				
a. Net Control Block (NCB) Transmission Unit (TU) (cont.)	Net Control Station (NCS) to Subscribers (cont.)		If the receiving subscriber is selected as NCS (i.e., the NCS receives an NCB TU from another subscriber), generate a Dual NCS alert.	When an NCS is active, all other subscribers shall be prevented, via software, from assuming NCS.
a. Net Control Block (NCB) Transmission Unit (TU) (cont.)	Net Control Station (NCS) to Subscribers (cont.)		<p>If the value of the NCS SID is the same as that assigned to the receiving subscriber, generate a Dual SID alert.</p> <p>If the value of the NCS SID is not the same as the last correct validation received on an NCB TU, generate a New NCS alert.</p> <p>If the receiving subscriber is not NCS, record the net as operational with the subscriber identified by the NCS SID field as the NCS.</p> <p>c. If validation of the WINDOW SIZE and HITS fields is achieved, update the current values of these items with those in these fields.</p> <p>d. If validation of the SB STATUS field is achieved and the contents of that field indicate that a scheduled broadcast requested by the receiving subscriber has been preempted, consider the broadcast completed.</p>	<p>Processing of NCB TU shall continue even when the WINDOW SIZE and HITS fields cannot be validated.</p> <p>Processing of the NCB shall continue even when the SB STATUS field cannot be validated.</p>

Table 4-2. Data Link and Network Layer Signal Flow (cont.)

SIGNAL	FROM/TO	INITIATION	RESPONSE	REMARKS
<p>Message Transfer (cont.)</p> <p>a. Net Control Block (NCB) Transmission Unit (TU) (cont.)</p>	<p>Net Control Station (NCS) to Subscribers (cont.)</p>		<p>e. If validation of the RATS TYPE, and FLASH and IMMEDIATE SLOTS fields is achieved and the receiving subscriber has an STU to transmit, randomly select an RS and send a RRTU in the RATS to request link time to transmit that STU.</p>	
<p>a. Net Control Block (NCB) Transmission Unit (TU) (cont.)</p>	<p>Net Control Station (NCS) to Subscribers (cont.)</p>		<p>f. If validation of the GSID, RATS TYPE, and FLASH and IMMEDIATE SLOTS fields is achieved and the contents of the GSID field matches the receiving subscriber's SID, the receiving subscriber has been granted authority to transmit.</p> <p>If an STU is available for transmission, the receiving subscriber shall immediately commence transmission of the STU. If additional link time is required, the subscriber shall notify NCS of the requirement by piggybacking a service request in the transmitted STU.</p>	<p>If the STU transmission is by scheduled broadcast, NCS shall authorize transmission by the subscriber no more than 45 seconds after the scheduled time. If it cannot, NCS shall notify the subscriber that the scheduled broadcast has been preempted. NCS control of STU transmission by scheduled broadcast shall be as described in section 6.</p>

Table 4-2. Data Link and Network Layer Signal Flow (cont.)

SIGNAL	FROM/TO	INITIATION	RESPONSE	REMARKS
<p>Message Transfer (cont.)</p> <p>a. Net Control Block (NCB) Transmission Unit (TU) (cont.)</p>	<p>Net Control Station (NCS) to Subscribers (cont.)</p>		<p>If no STU is available for transmission and the receiving subscriber has previously submitted a request for link time (via an RRTU or a piggy-backed request in an STU), the sub-scriber shall send a null STU; i.e., a STU containing no messages.</p> <p>If the receiving subscriber has not previously submitted a request for link time (via an RRTU or a piggybacked request in a STU), the sub-scriber shall ignore the authorization to transmit. No STU transmission shall occur.</p> <p>2. If the packet CRC was validated:</p> <p>a. If this is the first NCB received following STU transmission by this subscriber, the contents of the STU 1 ACKNOWLEDGE, STU 2 ACKNOWLEDGE, and STU 3 ACKNOWLEDGE fields shall be examined and:</p> <p>If the receiving subscriber's SID appears in one of those fields, an NCS Acknowledgement alert shall be generated.</p>	<p>The STU 1 ACKNOWLEDGE, STU 2 ACKNOWLEDGE, and STU 3 ACKNOWLEDGE fields shall be ignored if validation of the Data Link Layer packet containing the NCB could not be achieved.</p>

Table 4-2. Data Link and Network Layer Signal Flow (cont.)

SIGNAL	FROM/TO	INITIATION	RESPONSE	REMARKS
<p>Message Transfer (cont.)</p> <p>a. Net Control Block (NCB) Transmission Unit (TU) (cont.)</p>	<p>Net Control Station (NCS) to Subscribers (cont.)</p>		<p>If the receiving subscriber's SID does not appear in one of those fields, a No NCS Acknowledgement alert shall be generated.</p> <p>b. The receiving subscriber shall retain the LAQ information for use in the event that the subscriber must assume NCS responsibilities.</p>	<p>The LAQ information shall be ignored if validation of the Data Link Layer packet containing the NCB could not be achieved.</p>
<p>b. Reservation Request Transmission Unit (RRTU)</p>	<p>Subscriber to NCS</p>		<p>The receiving subscriber shall also validate that all its unfulfilled requests for link time are present. Any request for which an LAQ entry is not present shall be resubmitted.</p>	<p>If a request was made in the preceding net cycle, via an RRTU, and the subscriber's SID does not appear in the LAQ, a collision of the request with that of another subscriber has occurred and the subscriber shall perform the Contention Resolution Algorithm (CRA) as discussed in section 6.</p>

Table 4-2. Data Link and Network Layer Signal Flow (cont.)

SIGNAL	FROM/TO	INITIATION	RESPONSE	REMARKS
<p>Message Transfer (cont.) b. Reservation Request Transmission Unit (RRTU) (cont.)</p>	Subscriber to NCS (cont.)	<p>Following validation of the RATS TYPE, FLASH, and IMMEDIATE SLOTS fields of a received NCB, the RRTU is sent by a subscriber during one of the RSs in the RATS to request link time to transmit a STU.</p>	<p>The packet CRC of the Data Link Layer packet containing the RRTU shall be validated by calculating the packet CRC and comparing it with the CRC value present in that packet. If validation is not achieved, the packet shall be marked as bad and replaced with a packet received in a repeat transmission of the RRTU if such a transmission is received. After all repeats of the RRTU have been received or an error-free RRTU is received, processing of the RRTU shall continue as follows:</p>	<p>Processing of the RRTU's triply redundant fields shall be performed even when the packet CRC cannot be validated.</p>
<p>b. Reservation Request Transmission Unit (RRTU) (cont.)</p>	Subscriber to NCS		<p>1. If any of the RRTU's triply redundant fields cannot be validated, the request shall be ignored.</p> <p>2. If validation is achieved and:</p> <p>a. Contents of the SID field is the receiving station's SID, the request shall be ignored and a Dual SID alert shall be generated.</p>	<p>Validation of the triply redundant fields requires obtaining at least a two out of three match.</p>

Table 4-2. Data Link and Network Layer Signal Flow (cont.)

SIGNAL	FROM/TO	INITIATION	RESPONSE	REMARKS
<p>Message Transfer (cont.)</p> <p>b. Reservation Request Transmission Unit (RRTU) (cont.)</p>	<p>Subscriber to NCS (cont.)</p>		<p>b. Request is a non-scheduled request, the request shall be placed in the LAQ according to its precedence.</p> <p>c. Request is a scheduled request, the request shall be placed in the LAQ according to its precedence but shall be unavailable for selection until the time indicated in the request occurs. If the subscriber is already on the LAQ with a scheduled broadcast request, the RRTU Transmit Minute shall be used to update the subscriber's scheduled request entry.</p>	<p>Presence of the requester's SID in the LAQ provided in the next NCB TU sent by NCS shall serve as acknowledgement of receipt of the request. NCS processing of subscriber requests and the method by which those requests are entered into the LAQ are described in section 6.</p> <p>If the requester's SID does not appear in the LAQ received in the following net cycle, a collision of the request with that of another subscriber has occurred and the subscriber shall perform the Contention Resolution Algorithm (CRA) as discussed in section 6.</p>

Table 4-2. Data Link and Network Layer Signal Flow (cont.)

SIGNAL	FROM/TO	INITIATION	RESPONSE	REMARKS
<p>Message Transfer (cont.)</p> <p>c. Subscriber Transmission Unit (STU)</p>	<p>NCS/Sub- scriber to Subscriber</p>	<p>Sent by a subscriber in response to the receipt of an NCB TU designating the subscriber as the granted subscriber (i.e., the GSID field in the NCB contains the subscriber's SID). Sent by NCS when it determines that it is the granted subscriber (i.e., it has placed its SID in the GSID field of the NCB for this net cycle).</p>	<p>For each Data Link Layer packet containing the received STU, the packet CRC shall be validated by calculating the packet CRC and comparing it with the CRC value present in that packet. If validation is not achieved on a packet, that packet shall be marked as bad and replaced with a corresponding packet received in a repeat transmission of the STU if such a transmission is received.</p> <p>After all repeats of the STU have been received or an error-free STU is received, processing of the STU shall continue as follows:</p> <p>1. Validate the STU triply redundant fields.</p> <p>a. If validation of the CID field cannot be achieved, the STU shall be discarded. In that case, wait for the transmission of another TU.</p>	<p>Processing of the STU shall be performed even when all packet CRCs cannot be validated.</p> <p>Validation of the triply redundant fields requires obtaining a two out of three match.</p> <p>The received TU cannot be identified as an STU if the CID value is invalid.</p>

Table 4-2. Data Link and Network Layer Signal Flow (cont.)

SIGNAL	FROM/TO	INITIATION	RESPONSE	REMARKS
<p>Message Transfer (cont.)</p> <p>c. Subscriber Transmission Unit (STU) (cont.)</p>	NCS/Subscriber to Subscriber		b. If validation of the SID field is achieved and the SID is equal to the receiving subscriber's SID generate a Dual SID alert.	Processing of the STU shall be performed even when the contents of the SID field cannot be validated.
c. Subscriber Transmission Unit (STU) (cont.)	Subscriber to NCS		<p>2. Validate the contents of the Message Pointer Block by calculating a CRC on its fields (exclusive of the PCS field) and comparing it to the contents of the PCS field. If a match is not obtained, the entire STU shall be discarded.</p> <p>3. If the contents of the Message Pointer Block was validated, use the Message Pointers to extract each of the network messages from the STU. If the message is addressed to the receiving subscriber, process the message accordingly. If STU reception was via an OTCIXS II LC, formatted computer-to-computer messages are transferred to the TDP and TTY messages are transferred to the teletype. If STU reception was via an OTCIXS II LC (within a TGF), all messages are transferred to the TGP.</p>	<p>Individual messages in the STU cannot be properly delimited if the contents of the Message Pointer Block cannot be validated.</p> <p>Refer to TADIXS IDS Volume I for the format of the transport messages contained in the network messages.</p>

Table 4-2. Data Link and Network Layer Signal Flow (cont.)

SIGNAL	FROM/TO	INITIATION	RESPONSE	REMARKS
<p>Message Transfer (cont.)</p> <p>c. Subscriber Transmission Unit (STU) (cont.)</p>	Subscriber to NCS (cont.)	<p>Sent by a subscriber in response to the receipt of an NCB TU designating the subscriber as the granted subscriber (i.e., the GSID field in the NCB contains the subscriber's SID). The transmitting subscriber shall transmit the STU the number of times specified in the received NCB TU.</p>	<p>Messages containing embedded errors (i.e., CRC at end of message does not match computed CRC over message) shall be so noted when transferred to the TDP or TGP.</p> <p>For each Data Link Layer packet containing the received STU, the packet CRC shall be validated by calculating the packet CRC and comparing it with the CRC value present in that packet. If validation is not achieved on a packet, that packet shall be marked as bad and replaced with a corresponding packet received in a repeat transmission of the STU if such a transmission is received. After all repeats of the STU have been received or an error-free STU is received, processing of the STU shall continue as follows:</p>	<p>Processing of the STU shall be performed even when all packet CRCs cannot be validated.</p>
Subscriber Transmission Unit (STU) (cont.)	Subscriber to NCS (cont.)		1. Validate the STU triply redundant fields.	Validation of the triply redundant fields requires obtaining a two out of three match.
Subscriber Transmission Unit (STU) (cont.)	Subscriber to NCS (cont.)		a. If validation of the CID field cannot be achieved, the STU shall be discarded. In that case, wait for the transmission of another TU.	The received TU cannot be identified as an STU if the CID value is invalid.

Table 4-2. Data Link and Network Layer Signal Flow (cont.)

SIGNAL	FROM/TO	INITIATION	RESPONSE	REMARKS
<p>Message Transfer (cont.)</p> <p>Subscriber Transmission Unit (STU) (cont.)</p>	Subscriber to NCS (cont.)		b. If validation of the SID field is achieved and the SID is equal to the receiving subscriber's SID, generate a Dual SID alert.	Processing of a piggy-backed RR shall not be performed if the contents of the SID field cannot be validated. Other portions of the STU shall be processed even when the contents of the SID field cannot be validated.
Subscriber Transmission Unit (STU) (cont.)	Subscriber to NCS (cont.)		c. If validation of the RESV, MODE, XMIT CT, TRANSMIT MINUTE, and MORE fields cannot be achieved, NCS shall not perform piggy-back net service request processing on the STU.	The NCS cannot identify the requesting subscriber's transmission requirements if these fields cannot be validated.
Subscriber Transmission Unit (STU) (cont.)	Subscriber to NCS (cont.)		d. If validation of the RESV, MODE, XMIT CT, TRANSMIT MINUTE, and MORE fields is achieved and the contents of the RESV field indicates that the subscriber has piggybacked a request for additional net service in the STU:	

Table 4-2. Data Link and Network Layer Signal Flow (cont.)

SIGNAL	FROM/TO	INITIATION	RESPONSE	REMARKS
<p>Message Transfer (cont.)</p> <p>Subscriber Transmission Unit (STU) (cont.)</p>	Subscriber to NCS (cont.)		<p>If the request was for nonscheduled services, the request shall be placed in the LAQ according to its precedence. Presence of the requester's SID in the LAQ provided in the next NCB TU sent by NCS shall serve as acknowledgement of receipt of the request.</p>	<p>NCS processing of subscriber requests and the method by which those requests are entered into the LAQ are as described in section 6.</p>
Subscriber Transmission Unit (STU) (cont.)	Subscriber to NCS (cont.)		<p>If the request is for scheduled services, the request shall be placed in the LAQ according to its precedence but shall be unavailable for selection until the time indicated in the request occurs. Presence of the requester's SID in the LAQ provided in the next NCB TU sent by NCS shall serve as acknowledgement of receipt of the request.</p> <p>e. If validation of the MORE field is achieved and its contents indicates that the requesting subscriber has an additional service requirement for STU transmission on the current broadcast schedule, the NCS shall indicate the requesting subscriber's SID as the Granted SID (GSID) in the next NCB it sends.</p>	<p>If a Flash precedence entry is present in the LAQ or if more than five minutes have elapsed since the onset of the first net cycle allocated to this scheduled broadcast, the NCS shall reject the request and indicate the rejection by including a scheduled</p>

Table 4-2. Data Link and Network Layer Signal Flow (cont.)

SIGNAL	FROM/TO	INITIATION	RESPONSE	REMARKS
<p>Message Transfer (cont.)</p> <p>Subscriber Transmission Unit (STU) (cont.)</p>	Subscriber to NCS (cont.)		e. (cont.)	<p>broadcasting status of preempted in the next NCB it sends. Upon detecting this status, subscribers monitoring the scheduled broadcast shall consider the scheduled broadcast to be concluded.</p>
Subscriber Transmission Unit (STU) (cont.)	Subscriber to NCS (cont.)		<p>2. Validate the contents of the Message Pointer Block by calculating a CRC on its fields (exclusive of the PCS field) and comparing it to the contents of the PCS field. If a match is not obtained, the entire STU shall be discarded.</p> <p>3. If the contents of the Message Pointer Block was validated, use the Message Pointers to extract each of the network messages from the STU. If the message is addressed to the NCS, process the message accordingly. If STU reception was via an OTCIXS II LC, formatted computer-to-computer messages are transferred to the TDP and TTY messages are transferred to the teletype.</p>	<p>Individual messages in the STU cannot be properly delimited if the contents of the Message Pointer Block cannot be validated.</p> <p>Refer to TADIXS IDS Volume I for the format of the transport messages contained in the network messages.</p>

Table 4-2. Data Link and Network Layer Signal Flow (cont.)

SIGNAL	FROM/TO	INITIATION	RESPONSE	REMARKS
<p>Message Transfer (cont.)</p> <p>Subscriber Transmission Unit (STU) (cont.)</p>	<p>Subscriber to NCS (cont.)</p>		<p>3. (cont.) If STU reception was via an OTCIXS II LC (within a TGF), all messages are transferred to the TGP.</p> <p>Messages containing embedded errors (i.e., CRC at end of message does not match computed CRC over message shall be so noted when transferred to the TDP or TGP.</p>	

THIS PAGE INTENTIONALLY LEFT BLANK

V. COMMUNICATION CONTROLS AND CONVENTIONS

A. GENERAL.

This section provides a description of the requirements associated with transfer of data among OTCIXS II net members. Included are descriptions and procedures regarding:

1. Communication controls to provide data flow, data synchronization, error detection and correction.
2. Communication conventions to support OTCIXS II Link Controller initialization and information transfer.

OTCIXS II shall operate either via a permanently assigned UHF-DAMA Time Division Multiple Access (TDMA) baseband slot (i.e., DAMA Mode) or over an allocated UHF SATCOM channel (i.e., Non-DAMA Mode). The two modes are mutually exclusive; a given net may operate in one or the other of the two modes but not in both at the same time.

To support the transfer of data on the net, OTCIXS II shall implement a computer-to-computer protocol which employs a layering concept consistent with the International Standards Organization (ISO) reference model. Each layer builds upon the services provided by the lower layer and converses with its correspondent layer in the other processor. Figure 5-1 illustrates this layering concept.

B. COMMUNICATION CONTROLS.

The Physical, Data Link, and Network protocol layers shall provide the communication controls governing transfer of subscriber data among OTCIXS II net members. The support

provided by each of these protocol layers is described in the following paragraphs.

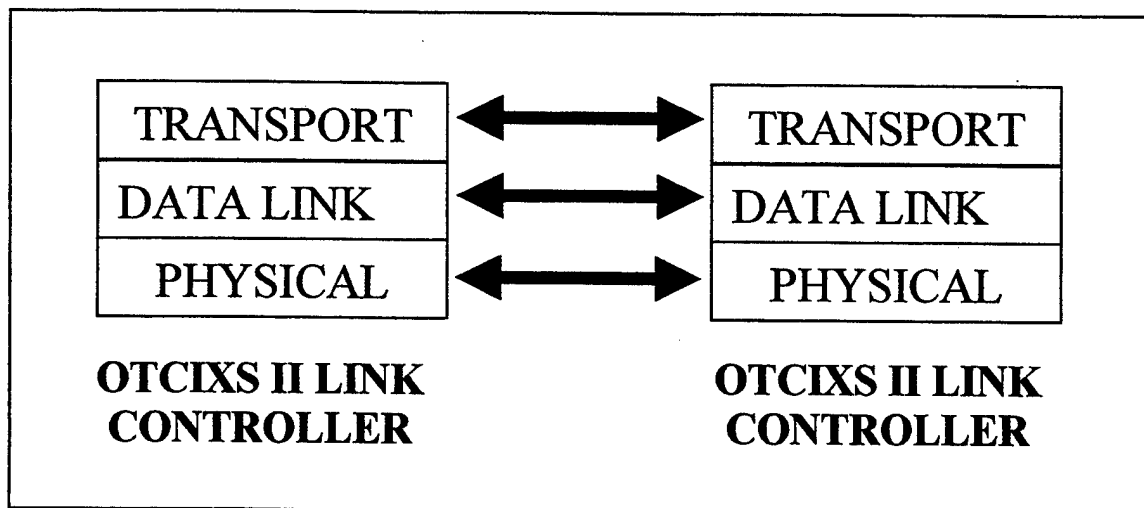

Figure 5-1. OTCIXS II Protocol Layers

1. Physical Layer.

The Physical Layer shall provide the physical means for supporting all higher protocol layers and consists of user baseband and radio frequency (rf) disciplines. These disciplines and the timing and sequencing of the physical layer signals are described in the following subparagraphs.

a. User Baseband.

In DAMA mode of operation, data shall be transferred serial synchronously in accordance with MIL-STD-188C at a baseband data rate of 1200 or 2400 bps. In Non-DAMA mode of operation, data shall be transmitted serial synchronously in accordance with MIL-STD-188C at a baseband data rate of 2400 or 4800 bps. The baseband data rate to be used in a particular OTCIXS II network shall be used by all members of that network. The data shall be transmitted in 8-bit bytes least significant bit first. Parity bits shall not be used. For the KG-84A cryptographic device, all user data transmissions shall be preceded by

transmission of one BISYNC code (two consecutive ASCII SYN (16 hexadecimal) codes).

b. Radio Frequency.

A given OTCIXS II rf network shall operate either over a permanently assigned UHF-DAMA user slot (DAMA mode) or over an assigned UHF Satellite communication channel (Non-DAMA mode).

(1). DAMA Mode. All members of a given DAMA Mode OTCIXS II rf network shall:

(a). Transmit on the same assigned uplink frequency and receive downlink broadcasts on the same translated downlink frequency.

(b). Transmit baseband data to, and receive baseband data from, a TD-1271B/U DAMA device operated with the Transmit Override option. The half-duplex mode of operation shall be used.

(c). Use a KG-84A cryptographic device.

The TD-1271B/U operates as a modem and as a time division multiplexer. It accumulates user baseband data over 1.38667 second frame-time intervals and bursts the accumulated data over the satellite link. These uplink data bursts are received from the downlink, buffered, and presented at the original baseband rate. User baseband data is buffered by the TD-1271B/U until it is time to present that data to the UHF uplink transmit subsystem. The size of a buffer (in bits) depends upon the user baseband rate and is the product of that rate and the frame time (rounded down to the nearest integer); a 2400 bps baseband rate employs a 3328-bit buffer. Unused portions of the buffer are padded with binary ones on the left to fill space between assertion of STM and reception of the first bit of the user's baseband transmission. In principle, the TD-1271B/U insulates its user(s) from the rf portion of the

satellite communication process and, in fact, physically separates those users from UHF radio transceiver equipment and their control signals.

(2). Non-DAMA Mode. All members of a given Non-DAMA Mode OTCIXS II rf network shall:

(a). Transmit on the same assigned uplink frequency and receive downlink broadcasts on the same translated downlink frequency. UHF uplink transmissions subject user baseband data to differentially encoded Biphasic Phase Shift Keyed (BPSK) modulation. Appropriate demodulation is applied to the copied downlink broadcast.

(b). Transmit data to, and receive data from, an AN/WSC-3(V) or AN/WSC-5(V) UHF radio transceiver. The half-duplex mode of operation shall be used.

c. Signal Timing and Sequencing.

The timing and sequencing of the Physical Layer signals in DAMA and Non-DAMA mode operations are presented in the following subparagraphs.

(1). DAMA Mode. Figure 5-2 illustrates the physical layer signals employed by the OTCIXS II Link Controller in the DAMA mode of operation. The timing and sequencing of these signals (for an NCB) is shown in Figures 5-3 through 5-6. Figures 5-3 through 5-6 are representative of timing requirements and are not to scale.

(a). Transmission. Transmissions shall be synchronized with the receipt of the STM from the DAMA multiplexer, which is generated by that device every 1.38667 seconds. Transmission of baseband data from an OTCIXS II station must commence 1.38667 seconds (one DAMA frame time) before that baseband data is burst on the uplink. A TD-1271B/U user may transmit continuously over several frame times; the continuity of the transmission is preserved as the received data is presented at each TD-1271B/U user port. The

OTCIXS II subscriber equipment inventory does not allow a transmitting platform to receive its own transmission or even to be aware of baseband transmissions initiated at the preceding Slot Time. The OTCIXS II Link Controller shall initiate DAMA Mode TU Transmission by asserting External Transmit Request (to the TD-1271B/U DAMA multiplexer) followed by Crypto PREP (to the KG-84A cryptographic unit).

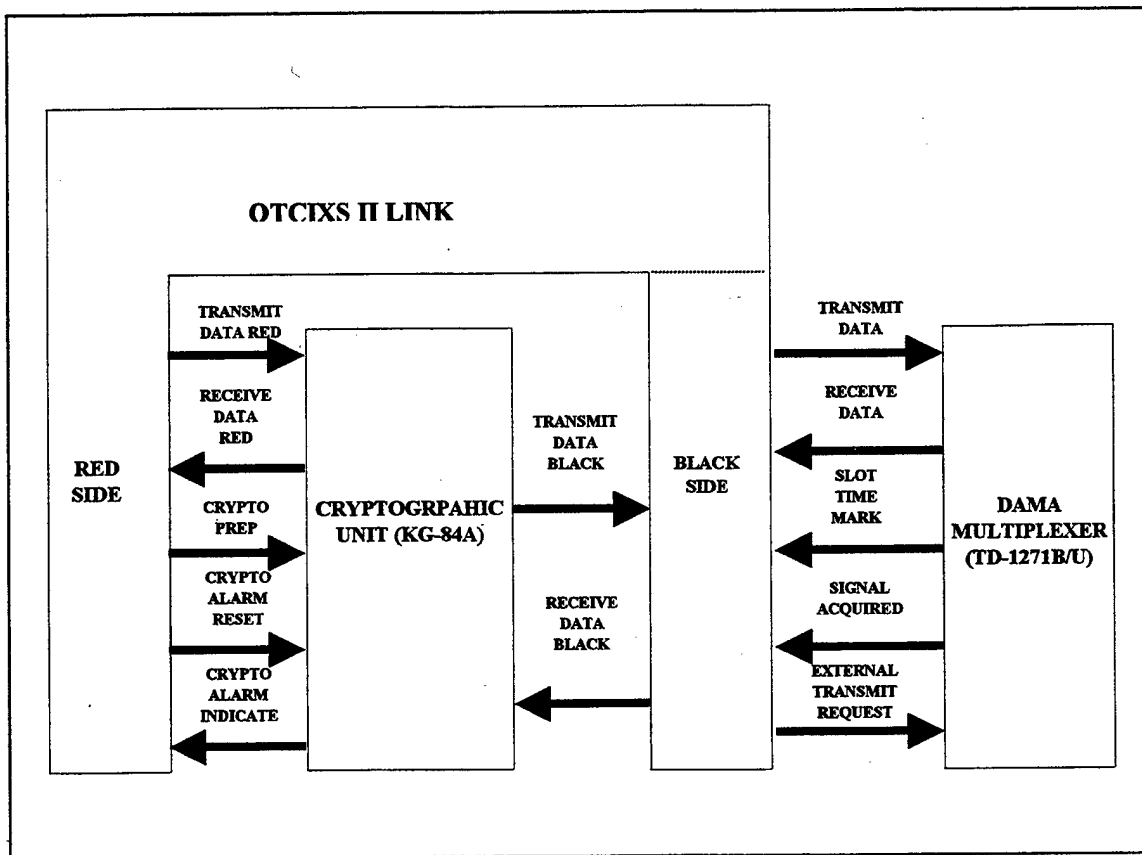

Figure 5-2. DAMA Configuration Physical Signals

Upon receipt of Crypto PREP, the KG-84A will execute an alarm check sequence, generate its preamble, and forward that preamble to the OTCIXS II Link Controller as Transmit Data Black. The OTCIXS II Link Controller shall then forward the received crypto preamble to the TD-1271B/U as Transmit Data. The OTCIXS II Link Controller shall delay sending its

transmit data, as Transmit Data Red, to the KG-84A to allow time for the KG-84A to complete execution of its alarm check sequence and generation of its preamble. This delay must be at least 289 ms (347 bit times) when a 1200 bps baseband rate is used and at least 152 ms (364 bit times) when a 2400 bps baseband rate is used. Upon receipt of the transmit data,

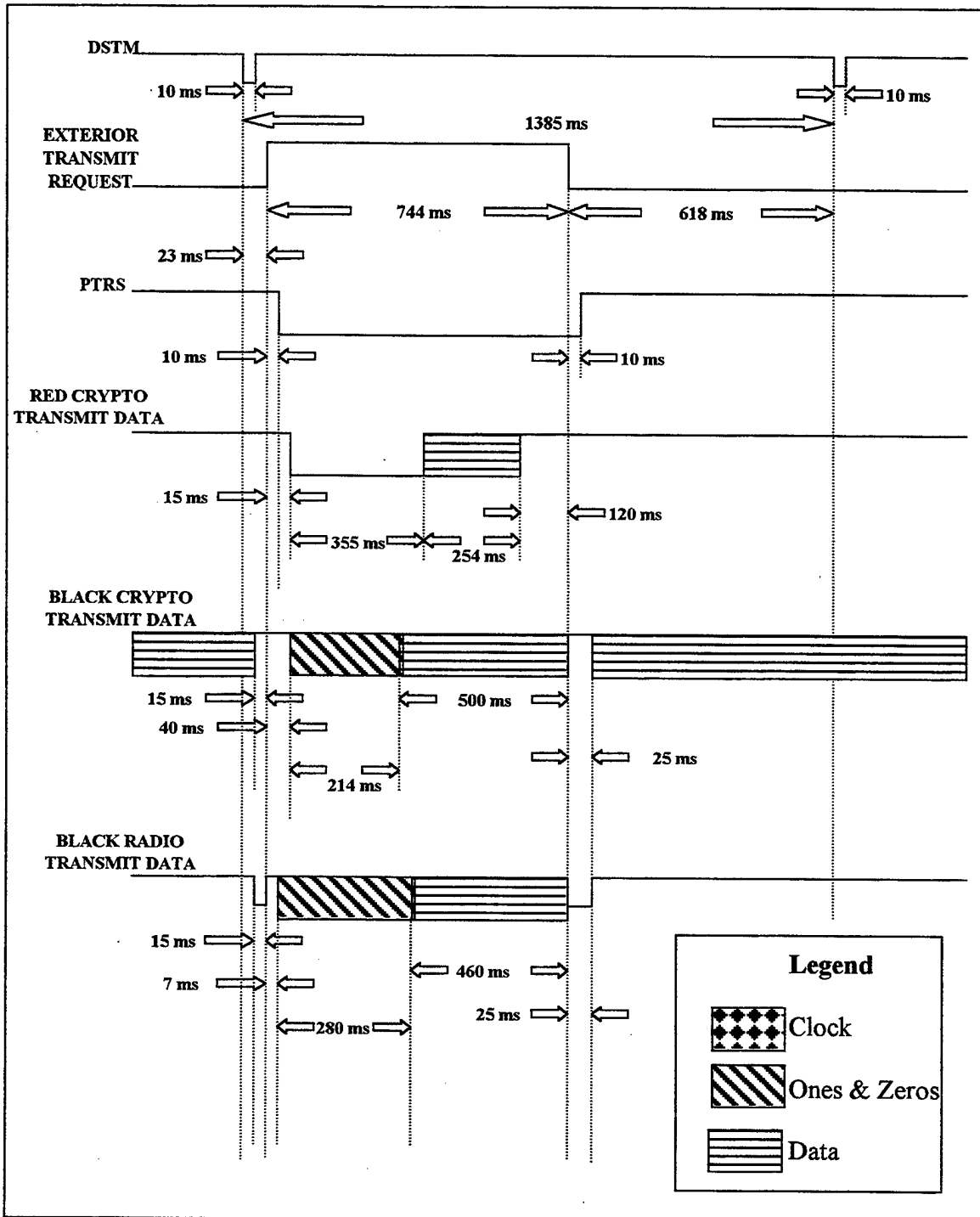

Figure 5-3. DAMA Configuration Physical Signal Timing: 1200 pbs KG-84A Transmit

the KG-84A will encrypt it and forward it to the OTCIXS II Link Controller as Transmit Data Black. The OTCIXS II Link Controller shall then forward the encrypted data to the TD-1271B/U as Transmit Data.

(b). Reception. The OTCIXS II Link Controller shall initiate DAMA Mode TU Reception upon receipt of SIGACQ from the TD-1271B/U. Upon receipt of Receive Data from the TD-1271B/U, the OTCIXS II Link Controller shall forward the received data to the KG-84A as Receive Data Black. Upon detection of a crypto preamble, the OTCIXS II Link Controller shall prepare to receive the transmitted TU. After the KG-84A has achieved synchronization with the transmitting KG-84A it will begin decrypting the TU. The decrypted data is then forwarded by the KG-84A to the OTCIXS II Link Controller as Receive Data Red.

From the perspective of downlink broadcast reception, net cycle slots are offset approximately 260 milliseconds (average uplink/downlink propagation time) from the uplink burst and approximately 1.65 seconds from the onset of a baseband transmission from an OTCIXS II Link Controller to its connected TD-1271B/U. One complete DAMA frame is lost whenever a station switches from a receiving to a transmitting stance. Hence, one frame is always lost after the NCB is transmitted. At least one, and occasionally two, frames are lost after each STTS.

(2). Non-DAMA Mode. Figure 5-7 illustrates the physical layer signals employed by the OTCIXS II Link Controller in the Non-DAMA mode of operation. The timing and sequencing of these signals (for an NCB) is shown in Figures 5-8 through 5-11.

(a). Transmission. The OTCIXS II Link Controller shall initiate

Non-DAMA Mode TU transmission by asserting Keyline to the AN/WSC-3/5 transceiver.

Immediately following Keyline assertion, the OTCIXS II Link Controller shall assert Crypto PREP to the cryptographic unit.

Upon receipt of Crypto PREP, the crypto will generate its preamble (an alarm check sequence will also be executed if the crypto is a KG-84A) and pass it to the OTCIXS II Link Controller as Transmit Data Black. The OTCIXS II Link Controller shall then forward the received crypto preamble to the AN/WSC-3/5 as Transmit Data. After a baseband rate and crypto-type dependent delay following assertion of Crypto PREP (to allow for transmission of the crypto preamble), the OTCIXS II Link Controller shall begin sending its transmit data to the crypto as Transmit Data Red. When the crypto is a KG-84A, this delay must be at least 152 ms

(364 bit times) when the baseband rate is 2400 bps or 80 ms (381 bit times) when the baseband rate is 4800 bps. Upon receipt of the transmit data, the crypto will encrypt it and forward it to the OTCIXS II Link Controller as Transmit Data Black. The OTCIXS II Link Controller shall then forward the encrypted data to the AN/WSC-3/5 as Transmit Data.

(b). Reception. The OTCIXS II Link Controller shall initiate Non-DAMA Mode TU Reception upon receipt of Channel Busy from the AN/WSC-3/5 transceiver. Upon receipt of Receive Data from the AN/WSC-3/5, the OTCIXS II Link Controller shall forward the received data to the crypto as Receive Data Black. Upon detection of a crypto preamble, the OTCIXS II Link Controller shall prepare to receive the transmitted TU. After the crypto has achieved synchronization with the transmitting crypto, it will begin decrypting the TU. The decrypted data is then forwarded by the

crypto to the OTCIXS II Link Controller as Receive Data Red.

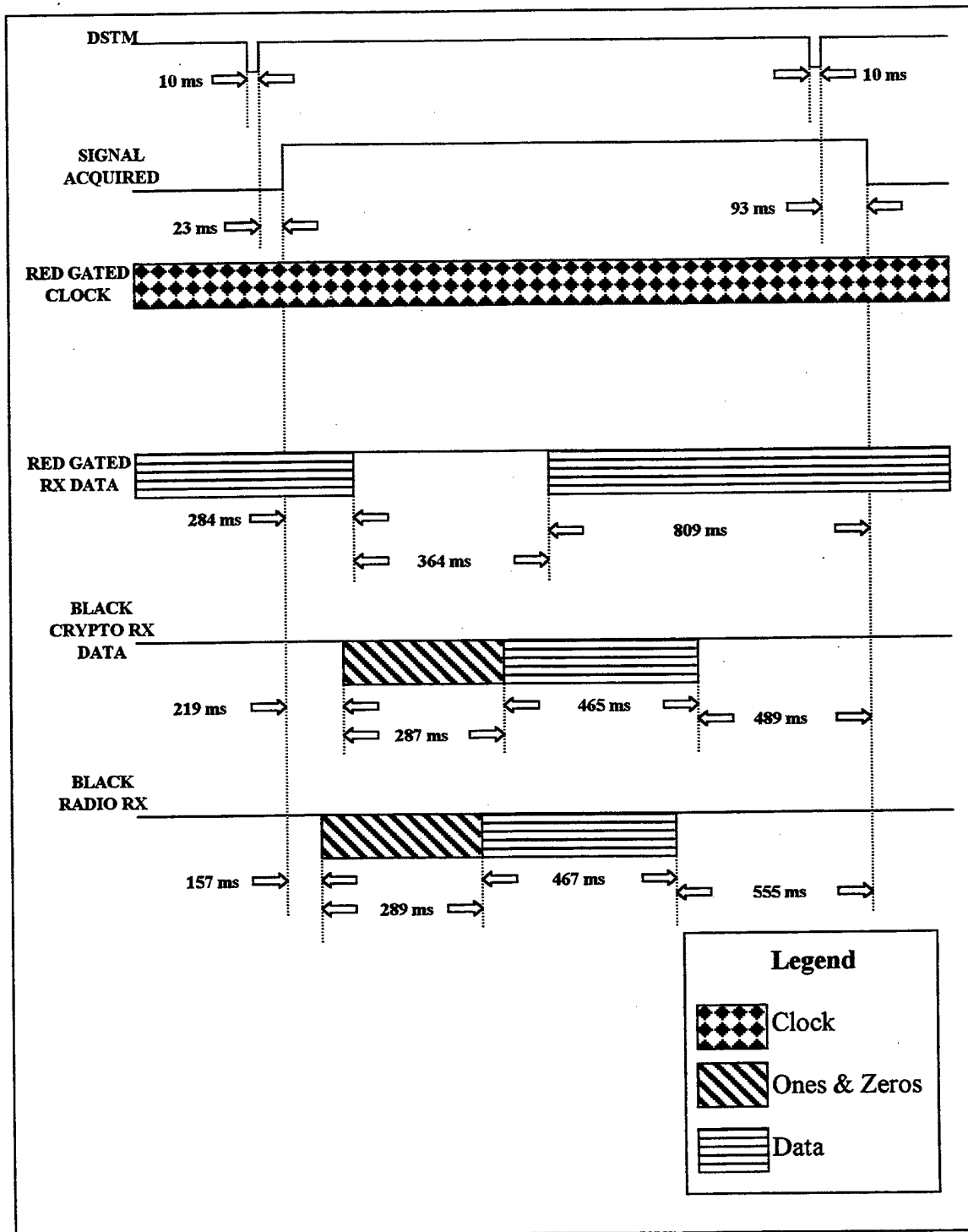

Figure 5-4. DAMA Configuration Physical Signal Timing: 1200 bps KG84A Receive

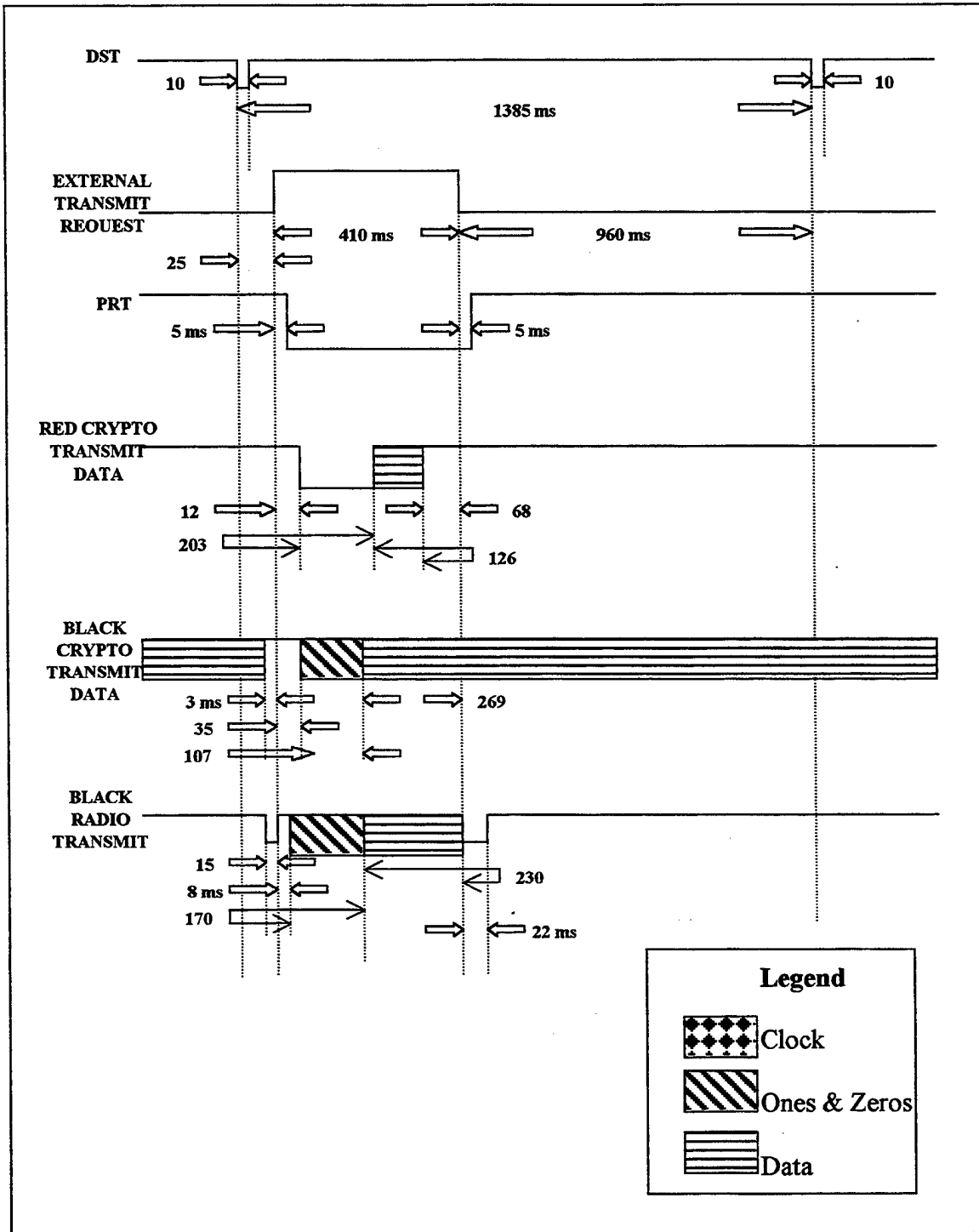

Figure 5-5. DAMA Configuration Physical Signal Timing: 2400 bps KG-84A Transmit

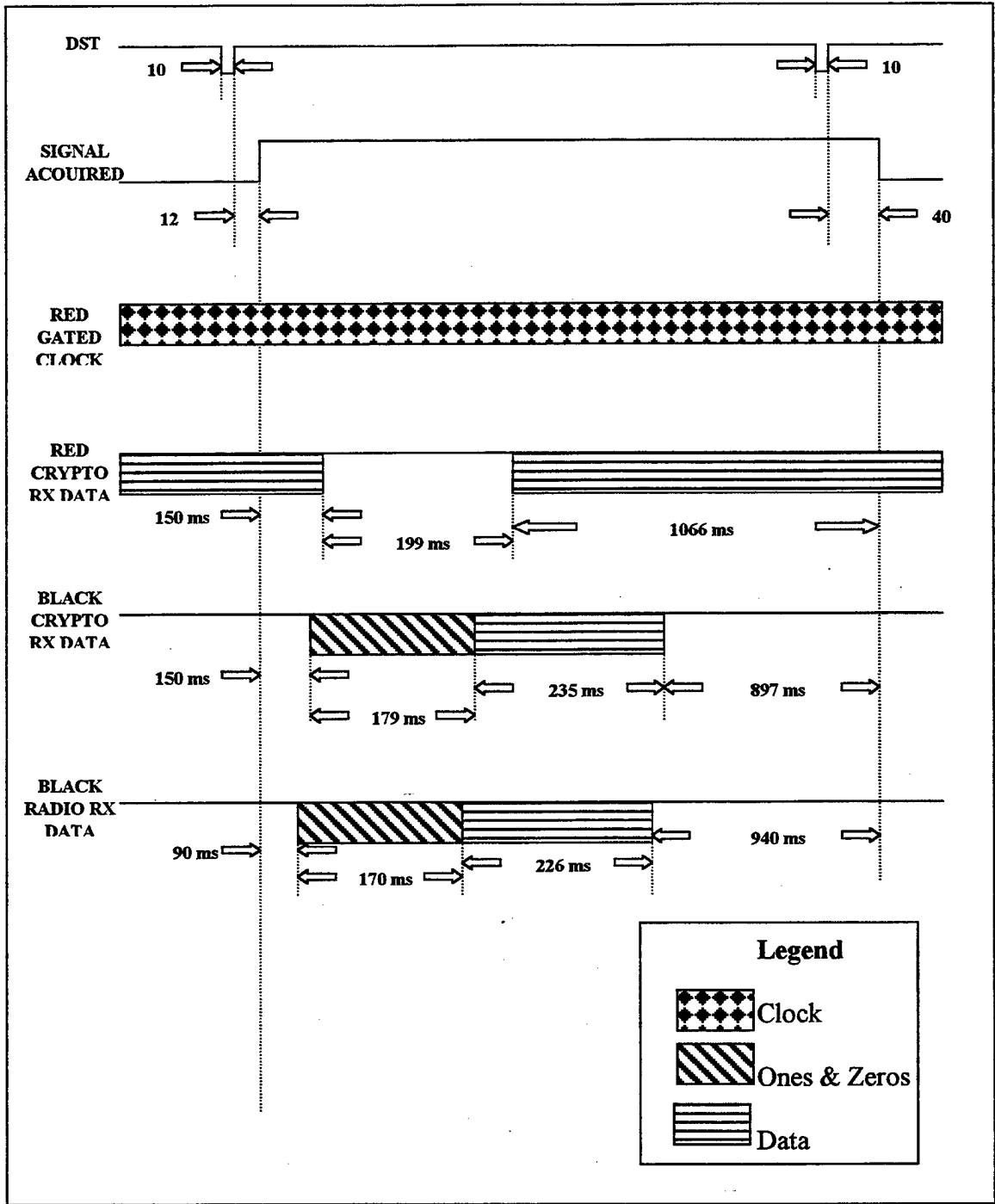

Figure 5-6. DAMA Configuration Physical Signal Timing: 2400 bps KG-84A Receive

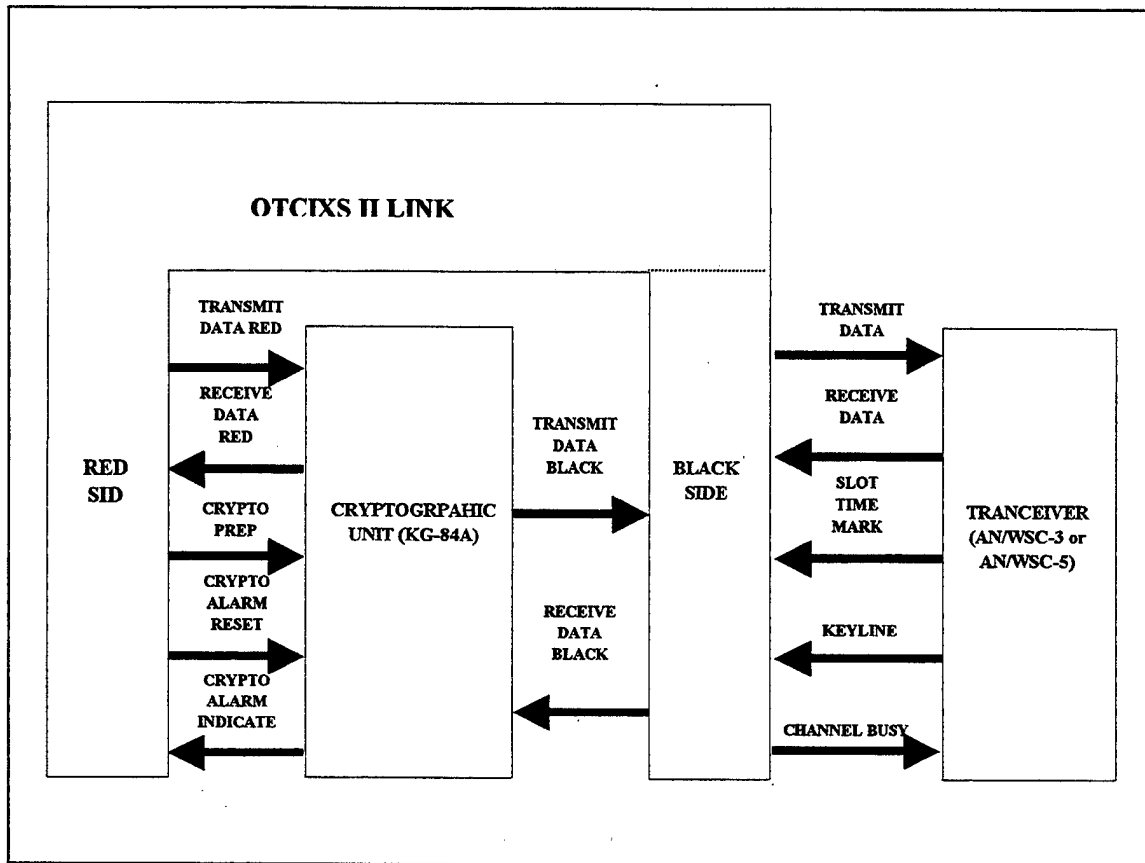

Figure 5-7. Non-DAMA Configuration Physical Signals

d. Crypto Error Handling.

Upon receipt of Crypto Alarm Indicate, the OTCIXS II Link Controller shall attempt to clear the indicated alarm condition by asserting Crypto Alarm Reset to crypto. The crypto will respond by attempting to take itself out of the alarm state. If the crypto can clear the alarm condition, it will remove the Crypto Alarm Indicate signal. If the crypto cannot clear the condition, the OTCIXS II Link Controller will reassert Crypto Alarm Reset. If three consecutive attempts to clear the alarm condition are unsuccessful, the OTCIXS II Link Controller shall report the interface as inoperable and continue attempting to clear the alarm.

2. Data Link Layer.

The OTCIXS II data link layer shall provide reliable data flow between the physical and network layers. It shall organize an outgoing (uplink) broadcast data structure into a sequence of 100-byte packets and supervise the output of each packet as an emitted bit stream. It shall also reassemble an incoming downlink bit stream into bytes, then packets, and finally into the original transport entity that was broadcast. Each Data Link Layer packet shall be 100 bytes in length and, as illustrated in section 7, contain the following components:

a. **END** -- a 1-bit flag indicating whether the packet is the final packet of a multipacket transmission.

b. **COUNT** -- a 7-bit value indicating the number of data bytes contained in the packet. Legal values are 1 through 97. For multipacket transmissions, all packets except the final packet.

c. **INFORMATION** -- an array of "Byte Count" bytes of data containing part or all of a TU.

d. **CRC** -- a 2-byte CRC sequence computed over the Transmission End, Byte Count, and Data components of the packet. The CRC may be computed by software or by the ZILOG SIO hardware in the OTCIXS II Link Controller. The algorithm used to calculate the CRC is presented in Appendix B. shall contain 97 bytes. The final packet may contain from 1 through 97 bytes.

The Data Link layer shall provide limited error control by computing CRC values for, and appending those values to, each outgoing (uplink) packet. As packets are reassembled from the incoming (downlink) data stream, CRC values shall be computed and compared with those appended to the packets. Each packet for which the values match shall be considered error-free. Each packet for which the values do not match shall

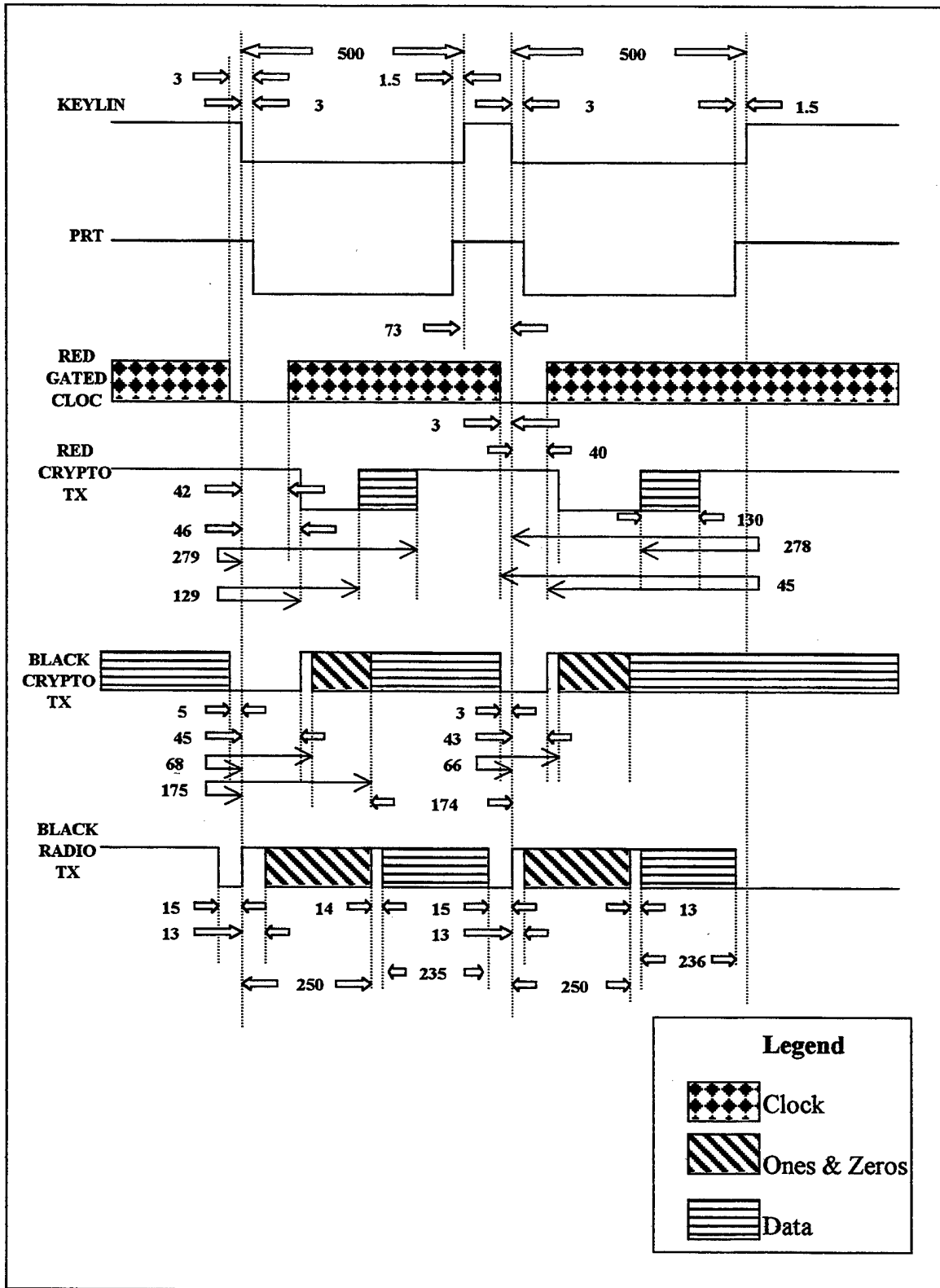

Figure 5-8. Non-DAMA Configuration Physical Signal Timing: 2400 bps KG-84A Transmit

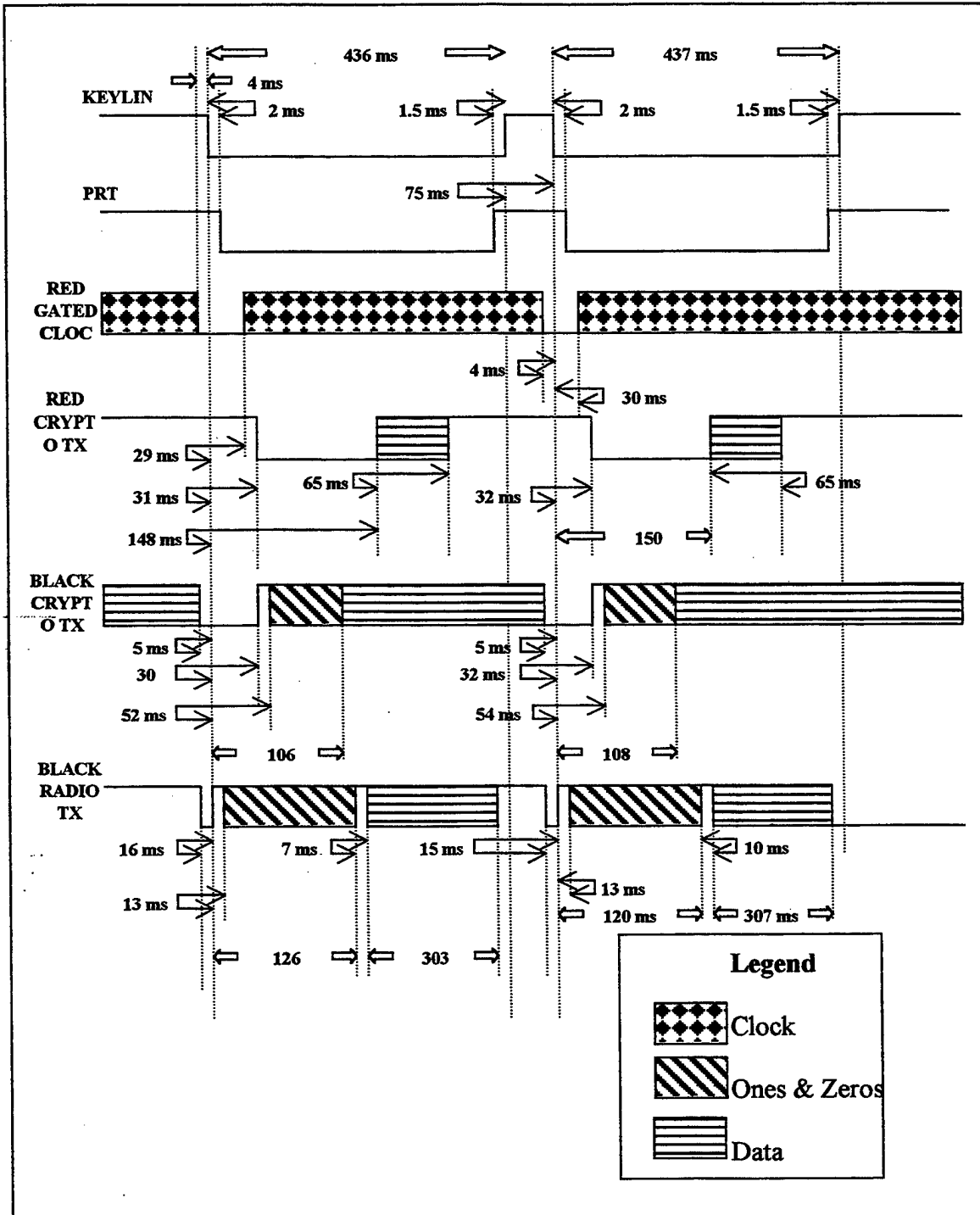

Figure 5-10. Non-DAMA Configuration Physical Signal Timing: 4800 bps KG-84A Transmit

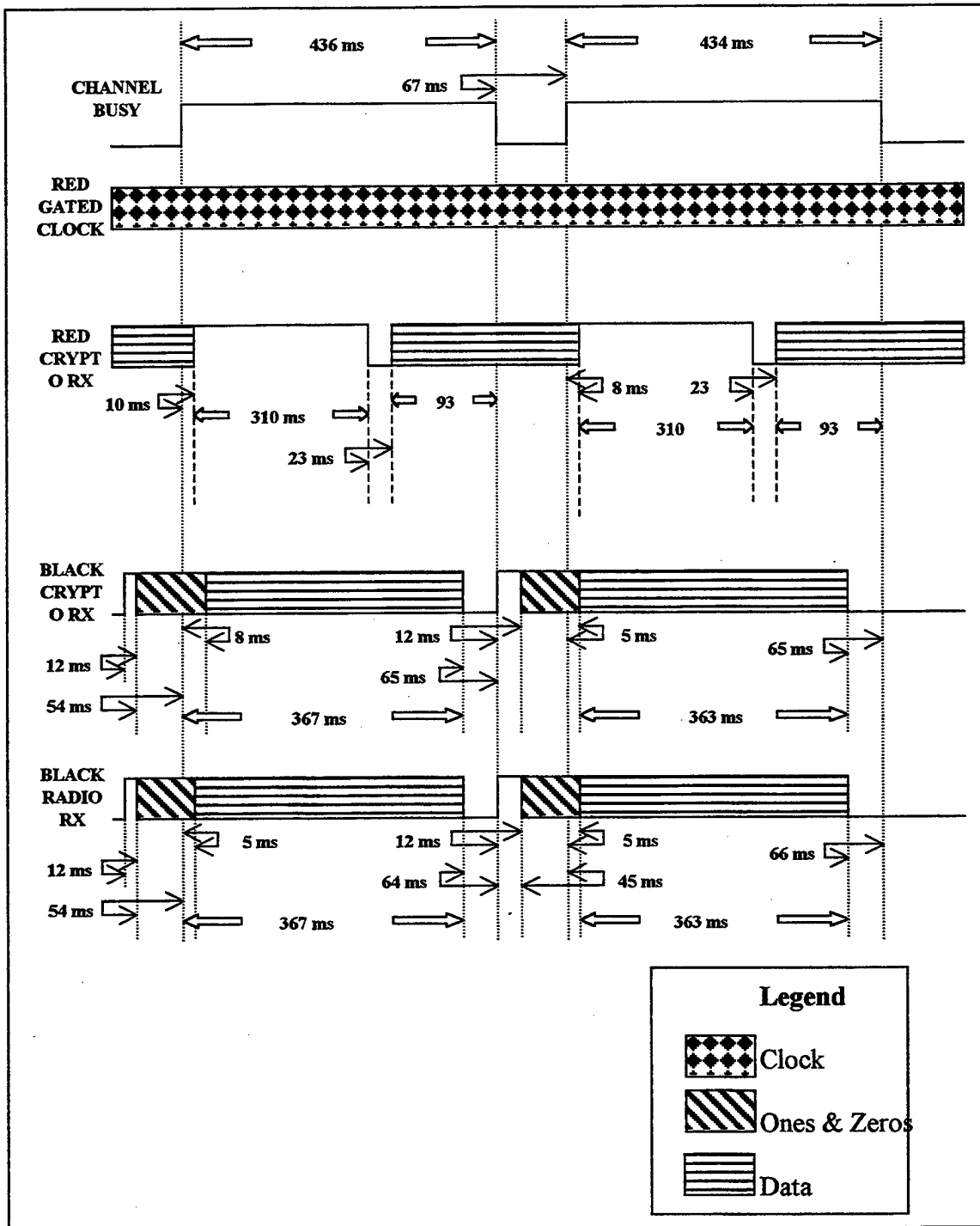

Figure 5-11. Non-DAMA Configuration Physical Signal Timing: 4800 bps Receive

be flagged as containing errors. Each received packet, without regard to the presence or absence of errors, shall be forwarded to the network layer.

3. Network Layer.

The Network Layer shall provide the management control under which orderly and reliable exchange of user information is permitted to occur. It involves the exchange of control, request, and subscriber data information between net members. The Network Layer assembles subscriber messages into STUs for transmission and extracts them from STUs received from the satellite downlink broadcast. Outgoing and incoming subscriber messages are passed between the Network Layer and the Transport Layer. The Transport Layer is beyond the scope of this document.

a. Net Cycle Structure. The network layer partitions channel time into an unbounded sequence of units called "net cycles". The same basic net cycle structure is employed for both DAMA and Non-DAMA modes of operation with differences being limited to timing details. Each net cycle is subdivided into an internal structure consisting of various combinations of the following:

1. **CTS** -- This time slot is used by the NCS for transmission of the NCB to all net members to initiate a net cycle and convey information about the current net cycle.
2. **RATS** -- This time slot is used by net members, on a contention basis, for transmission of RRTUs. The RATS is always present and consists of a set of subintervals called Request Slots (RS). Except during net initialization, there are three RSs, identified as RS1 through RS3, in the RATS. During net initialization, there are eight RSs, identified as RS1 through RS8, in the RATS.
3. **STTS** -- This time slot is used by net members for transmission of STUs containing subscriber messages. The STTS is present only when a subscriber transmission has

been authorized by the NCS.

Replicate transmissions of data in these time slots shall be used to increase the probability that each net member, including the NCS, will receive at least one copy of whatever is being broadcast. Moreover, in the case of STUs, multiple transmissions with selective packet replacement increases the probability that net members can reconstruct error-free composite copies of transmitted subscriber data. The NCB and RR transmissions per cycle shall depend upon the operating mode and baseband transfer rate as shown in Table 5-1. The STU transmissions per cycle shown in Table 5-1 represent default values for each combination of net mode and baseband rate. The actual times that a STU will be transmitted shall be specifiable by the net member in the range of one to three.

b. Net Cycle Initiation.

Each net cycle shall be initiated by transmission of an original and from zero to one copies of the NCB created by the NCS. The transmission shall be preceded by a fresh crypto preamble, and, in the case of the Non-DAMA operating mode, a fresh modem preamble. Critical information conveyed by the NCB shall be triply NCB shall be conveyed over the link in (i.e., as a passenger in) a single OTCIXS II packet. Each encoded and receiving net members shall consider the contents of a critical information field to be valid when two out of the three decoded values are equal. Each information field of the NCB is treated separately.

Table 5-1. TU Transmissions per Net Cycle

Mode	Baseband Rate	TU Transmissions per Cycle		
		NCB	RR	STU
DAMA	1200 bps	1	1	2
DAMA	2400 bps	1	2	2
Non-DAMA	2400 bps	2	2	2
Non-DAMA	4800 bps	2	2	3

Hence, the presence of bit errors in a received NCB shall not cause that NCB to be rejected. The NCB shall include the following critical information fields:

1. **CID** - Identifies the TU as an NCB
2. **COPY** - Identifies which copy of the NCB has been received
3. **RATS_TYPE** - Identifies the type of RATS supported in this net cycle
4. **NCS_SID** - Identifies the subscriber functioning as NCS
5. **GRANTED_SID** - Identifies the subscriber (if any) to whom STTS has been allocated
6. **XMIT_CT** - If STTS has been allocated to a subscriber in this net cycle, identifies the number of times that subscriber is to transmit a STU in the STTS
7. **FLASH_SLOTS** - Indicates the number of Flash precedence RSs in this net cycle's RATS
8. **IMMEDIATE_SLOTS** - Indicates the number of Immediate precedence RSs in this net cycle's RATS
9. **MODE** - Identifies the type of service provided during this net cycle
10. **SB_STATUS** - Indicates the status of scheduled broadcasting during

this net cycle

11. WINDOW_SIZE - Indicates the size of the window, in net cycles, to be used by net members in predicting their network service requirements

12. HITS - Indicates the number of net cycles, within the window specified by the WINDOW_SIZE field, in which a net member must receive at least one message for transmission in order to predict a network service requirement.

In addition, the NCB shall include the current LAQ which identifies all outstanding subscriber requests for network services. The NCB shall also include system time and, when appropriate, STU acknowledgments.

c. Net Cycle Types.

OTCIXS II shall provide two cycle types: Idle and Busy.

(1). Idle Cycle. An idle cycle shall consist of a CTS and a RATS. No STTS is present. Idle cycles occur only when there are no pending subscriber requests for network service. Figure 5-12 illustrates the generic structure of the idle cycle and its use.

(2). Busy Cycle. A busy cycle shall consist of a CTS, a RATS, and an STTS. A busy cycle occurs as the result of the NCS authorizing a net member to transmit an STU in that cycle. Figure 5-13 illustrates the generic structure of the busy cycle and its use.

d. Net Cycle Timing.

The detailed time structure of net cycles with respect to DAMA and Non-DAMA mode operations is presented in the following paragraphs.

(1). DAMA Mode. DAMA mode net cycle time slot events shall be synchronized on STM signals asserted by the TD-1271B/U Multiplexer. Individual

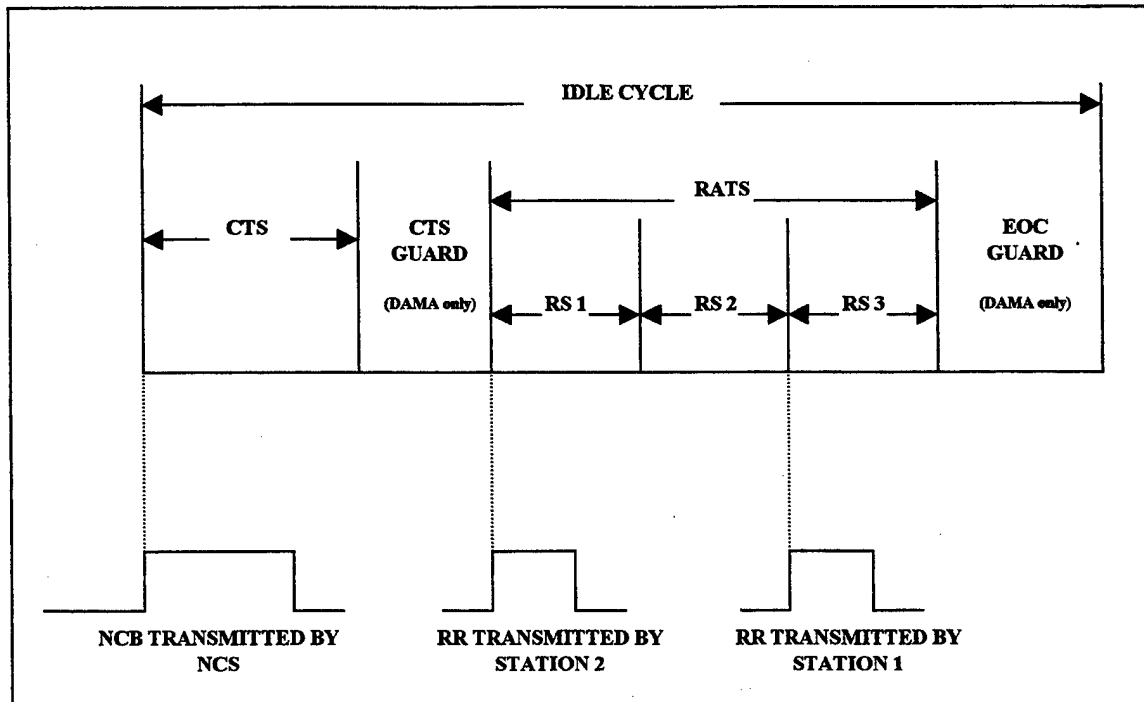

Figure 5-12. Idle Cycle Structure and Use

NOTES: 1. Each "transmission" shown may actually involve multiple physical transmissions - each preceded by all required preambles. The number of physical transmissions to be performed is dependent on the selected net operating mode (DAMA/Non-DAMA) and baseband data rate as shown in Table 5-1.

2. NCS transmits an NCB in the CTS to initiate the net cycle. The RATS TYPE field of this NCB indicates "Normal RATS".

3. Station 1 determines that it has an STU to send, randomly selects RS3, and sends an RRTU in RS3 of the RATS to indicate its transmission requirement.

4. Station 2 determines that it has an STU to send, randomly selects RS1, and sends an RRTU in RS1 of the RATS to indicate its transmission requirement.

transmissions involve integral numbers of DAMA frames of 1.38667 seconds duration. The CTS occupies one DAMA frame as does each RS in the RATS. The STTS can occupy more than one DAMA frame. DAMA Mode timing details regarding the CTS, RATS, and STTS are illustrated in Figures 6-14, 6-15, and 6-16 respectively. From these figures it can be seen that the minimum net cycle length in DAMA Mode operation is 6 DAMA frames (1 for CTS, 1 for CTS guard, 3 for RATS, and 1 for End of Cycle (EOC) guard) or 8.32 seconds regardless of baseband rate. Assuming a busy cycle with three transmissions of a maximum

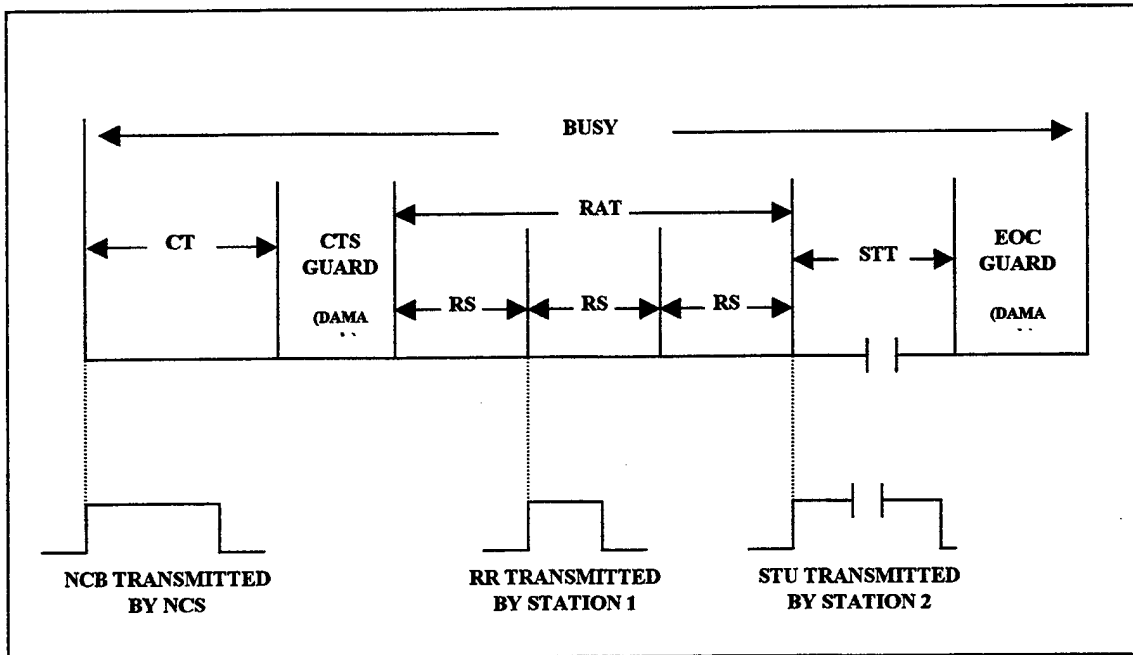

Figure 5-13. Busy Cycle Structure and Use

NOTES: 1. Each "transmission" shown may actually involve multiple physical transmissions - each preceded by all required preambles. The number of physical transmissions to be performed is dependent on the selected net operating mode (DAMA/Non-DAMA) and baseband data rate as shown in Table 5-1.

2. NCS transmits an NCB in the CTS to initiate the net cycle. The RATS TYPE field of this NCB field indicates "Normal RATS".

3. Station 1 determines that it has an STU to send, randomly selects RS2, and sends an RRTU in RS2 of the RATS to indicate its transmission requirement.

4. Station 2 determines that it is the GSID, the station authorized by NCS to transmit an STU in the STTS of the current net cycle, and commences transmission of an STU. The requirement to transmit this STU was identified by station 2 through transmission of an RRTU in the RATS of a previous net cycle. That RRTU also identified the number of the subscriber intends to transmit the STU.

5. If the GSID is the NCS, there will be a RATS Guard slot following RS3 (DAMA only).

length STU, the maximum net cycle length is 115.09 seconds (83 DAMA frames) at a baseband rate of 2400 bps and 220.48 seconds (159 DAMA frames) at a baseband rate of 1200 bps.

(2). Non-DAMA Mode. Since there is no buffer delay in the rf uplink subsystem in the Non-DAMA operating mode, baseband data appears at receiving stations after the uplink/downlink propagation delay. Since STM signals are not available, each station must use a periodic (hardware) interval timer to track a cycle's structure.

Non-DAMA mode timing details regarding the CTS, RATS, and STTS are illustrated in Figures 5-17, 5-18, and 5-19 respectively. From these figures it can be seen that the minimum net cycle length in Non-DAMA Mode operation (regardless of baseband data rate) is approximately 6.4 seconds when the KG-84A is used. Assuming a busy cycle with three trans-missions of a maximum length STU, the maximum net cycle length in Non-DAMA Mode operations is approximately:

- (a). 112.44 seconds when a KG-84A is used with a 2400 bps
baseband rate
- (b). 59.70 seconds when a KG-84A is used with a 4800 bps
baseband rate

C. COMMUNICATION CONVENTIONS.

The following subparagraphs describe the synchronization and data transfer techniques net members shall employ to accomplish timely and orderly exchange of subscriber data.

1. Net Participation Modes.

Each member of an OTCIXS II net may participate in one of two roles; as the NCS or as a subscriber.

a. Net Control Station.

Each member of an OTCIXS II rf net, with the exception of submarine subscribers, shall, in addition to performing subscriber functions, be capable of functioning as NCS for that net. Two precedence levels are accommodated: Flash and Immediate. NCS shall provide service to Flash RRs before servicing Immediate RRs. Requests for scheduled broadcasts shall be treated as having no precedence prior to the requested

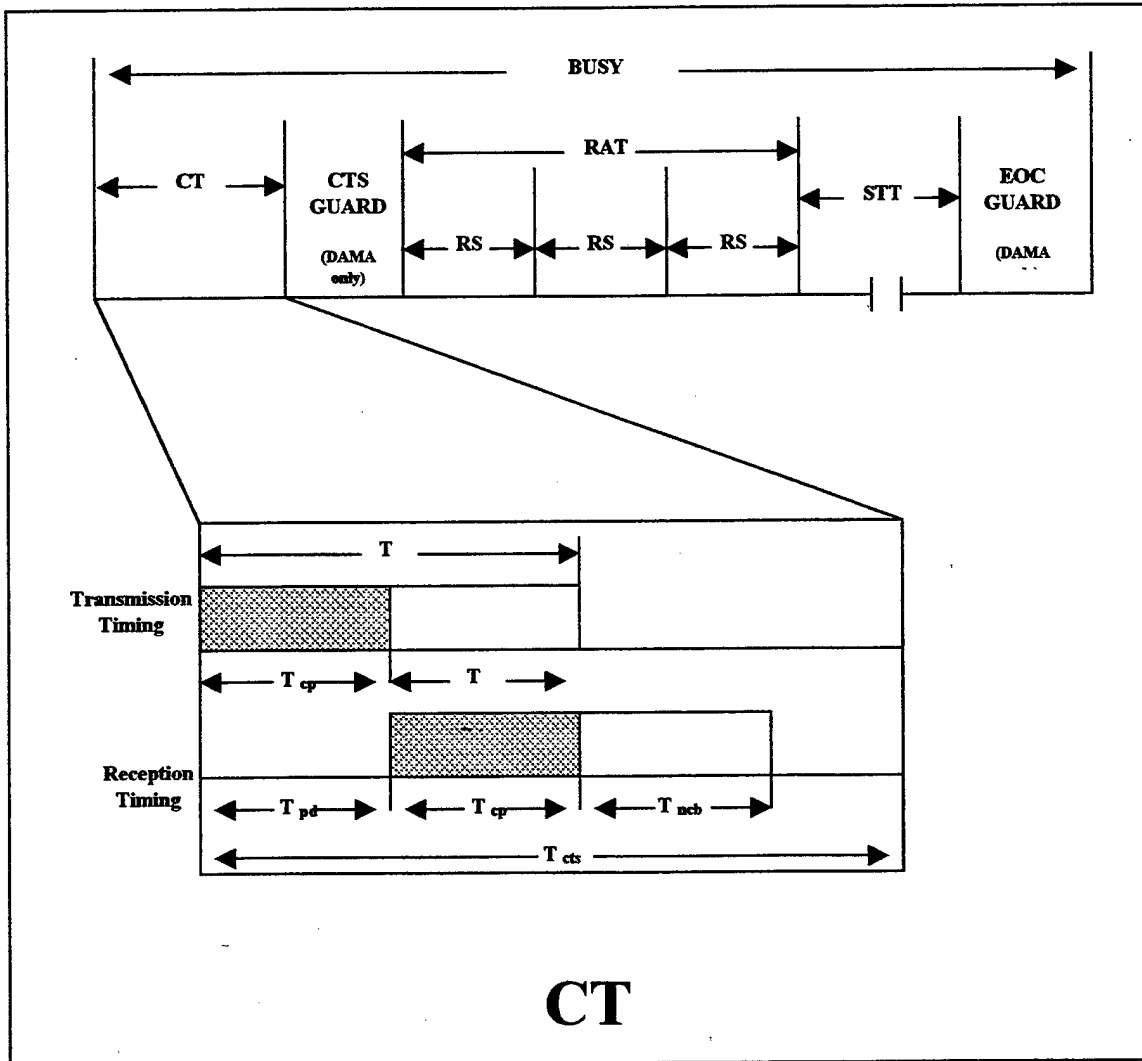

Where T_{cp} , T_{ncb} , T_{pd} , T_{xmit} , and T_{cts} are defined, in seconds, as follows:

KG-84A	Baseband Rate (bps)	
	1200	2400
T_{cp} [KG-84A preamble + BISYNC code]	0.35	0.20
T_{ncb} [NCB transmission time]	0.65	0.33
T_{pd} [propagation delay (± 0.01 sec)]	0.28	0.26
N [number of transmissions per cycle]	1	2
$T_{xmit} = T_{cp} + T_{ncb} + T_{pd}$ [total transmission time]	1.26	1.26
T_{cts} [CTS duration = 1 DAMA frame]	1.38667	1.38667

Figure 5-14. DAMA Mode OTCIXS II Timing – CTS

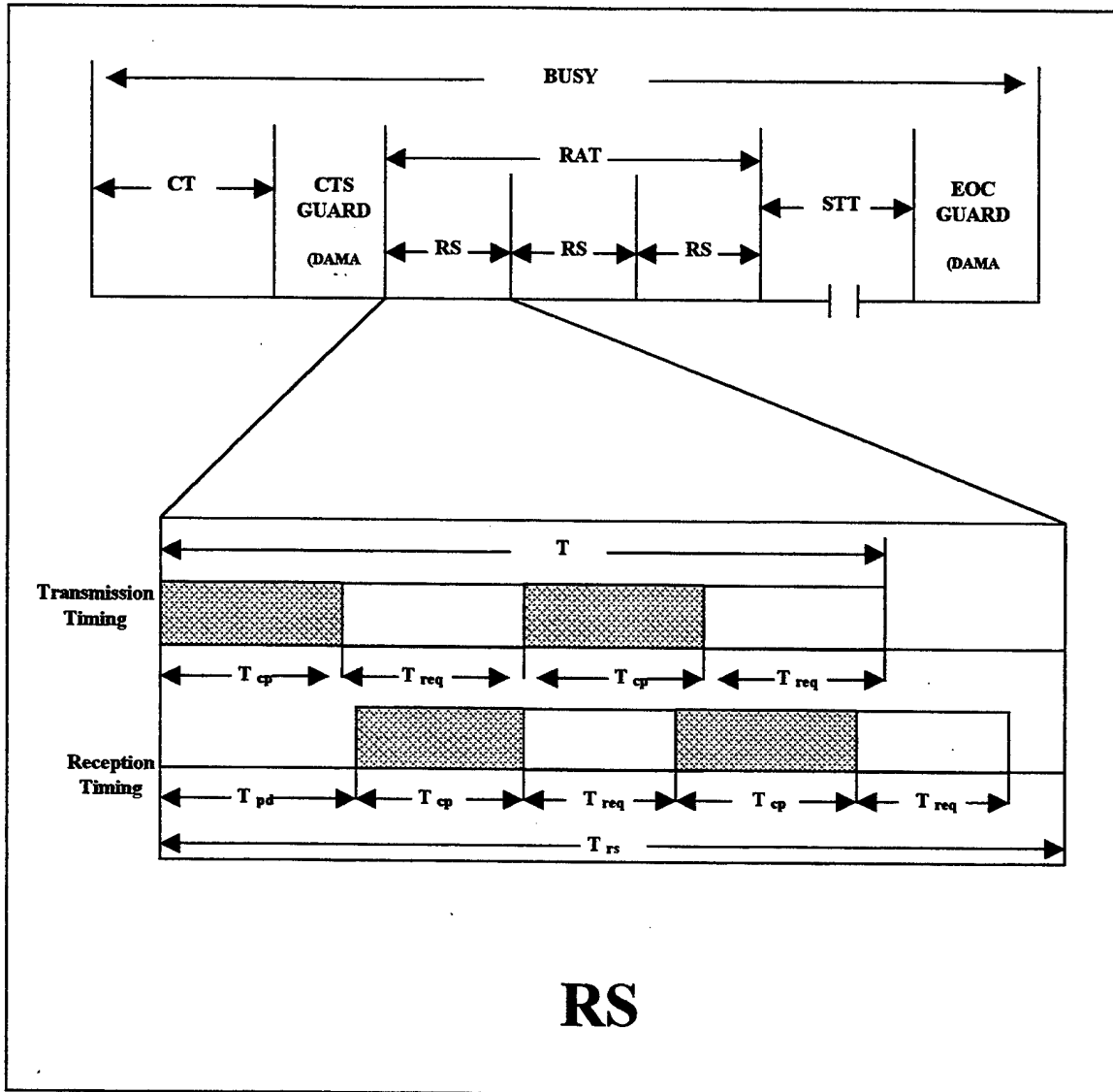

Where T_{cp} , T_{req} , T_{pd} , T_{xmit} , and T_{rs} are defined, in seconds, as follows:

KG-84A	Baseband Rate (bps)	
	1200	2400
T_{cp} [KG-84A preamble + BISYNC code]	0.35	0.20
T_{req} [RR transmission time]	0.12	0.06
T_{pd} [propagation delay (± 0.01 sec)]	0.28	0.28
N [number of transmissions per cycle]	1	2
$T_{xmit} = N * (T_{cp} + T_{req}) + T_{pd}$ [total transmission time]	.73	.78
T_{rs} [RS duration = 1 DAMA frame]	1.38667	1.38667

Figure 5-15. DAMA Mode OTCIXS II Timing – RATS

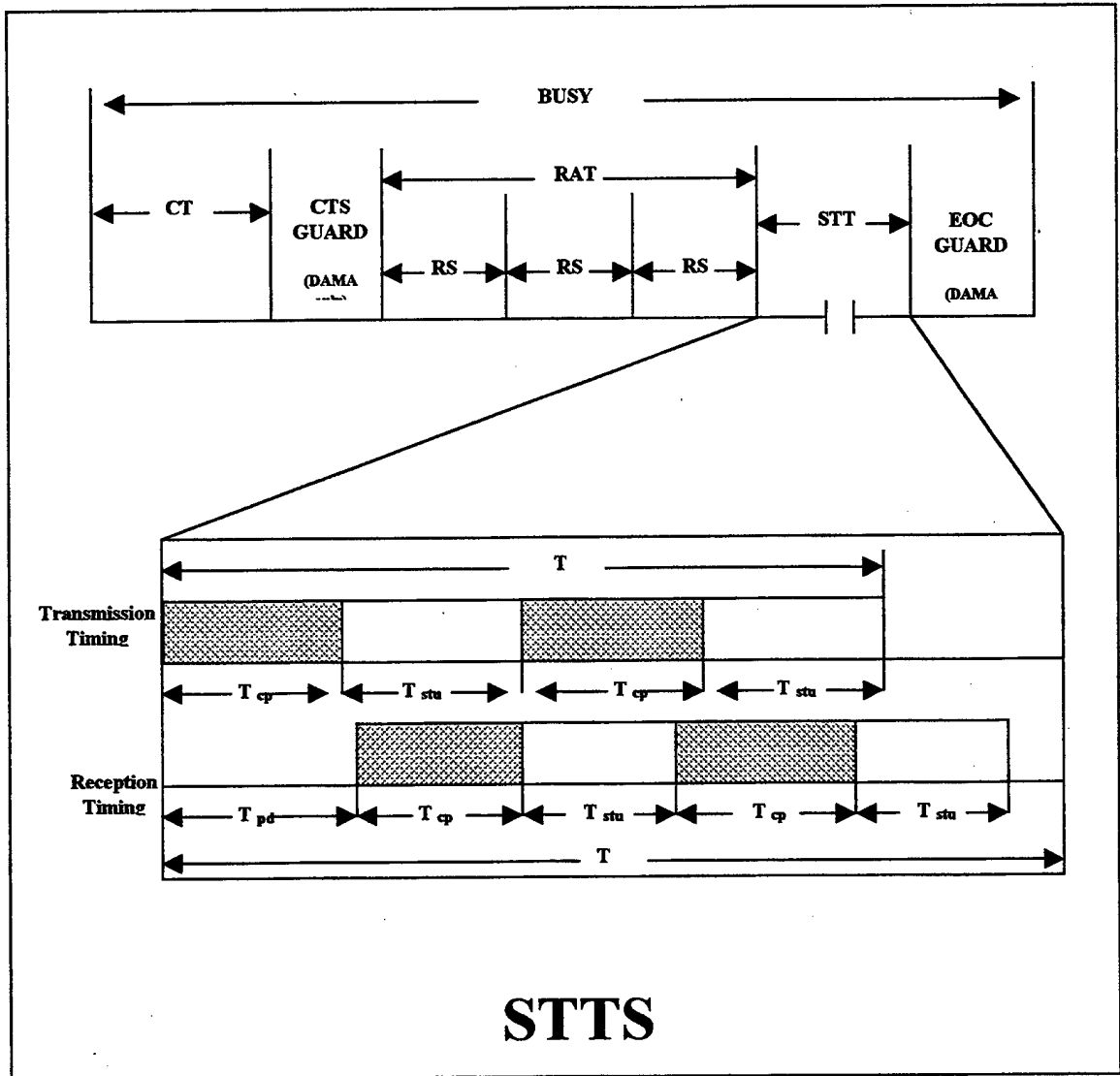

Where T_{cp} , T_{stu} , T_{pd} , T_{xmit} , and T_{sts} are defined, in seconds, as follows:

KG-84A	Baseband Rate (bps)	
	1200	2400
T_{cp} [KG-84A preamble + BISYNC code]	0.35	0.20
T_{stu} [max. length STU transmission time]	70.00	35.00
T_{pd} [propagation delay (± 0.01 sec)]	0.26	0.26
N [number of transmissions per cycle]	2	2
$T_{xmit} = N * (T_{cp} + T_{stu}) + T_{pd}$ [total transmission time]	140.88	70.58
T_{sts} [STTS duration (DAMA frames)]	141.44 (102)	70.72 (51)

Figure 5-16. DAMA Mode OTCIXS II Timing – STTS

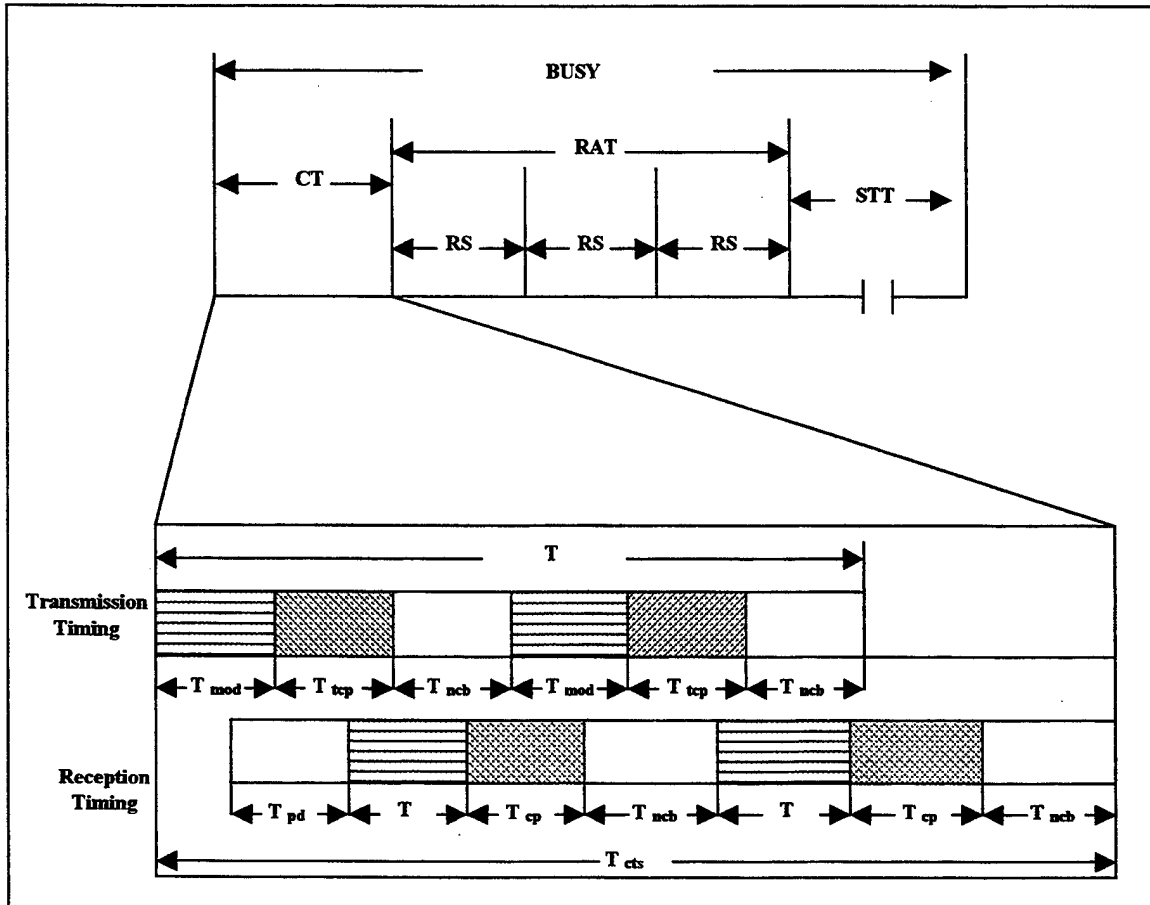

Where T_{cp} , T_{mod} , T_{ncb} , T_{pd} , T_{xmit} , and T_{cts} are defined, in seconds, as follows:

KG-84A	Baseband Rate (bps)	
	1200	2400
T_{cp} [KG-84A preamble + BISYNC code]	0.23	0.12
T_{mod} [modem preamble]	0.23	0.12
T_{ncb} [NCB transmission time]	0.33	0.16
T_{pd} [propagation delay (± 0.01 sec)]	0.26	0.26
N [number of transmissions per cycle]	2	2
$T_{xmit} = N * (T_{cp} + T_{mod} + T_{ncb}) + T_{pd}$ [total xmit T_{cts} time]	1.46	1.31
[CTS duration]	1.60	1.60

Figure 5-17. Non-DAMA Mode OTCIXS II Timing – CTS

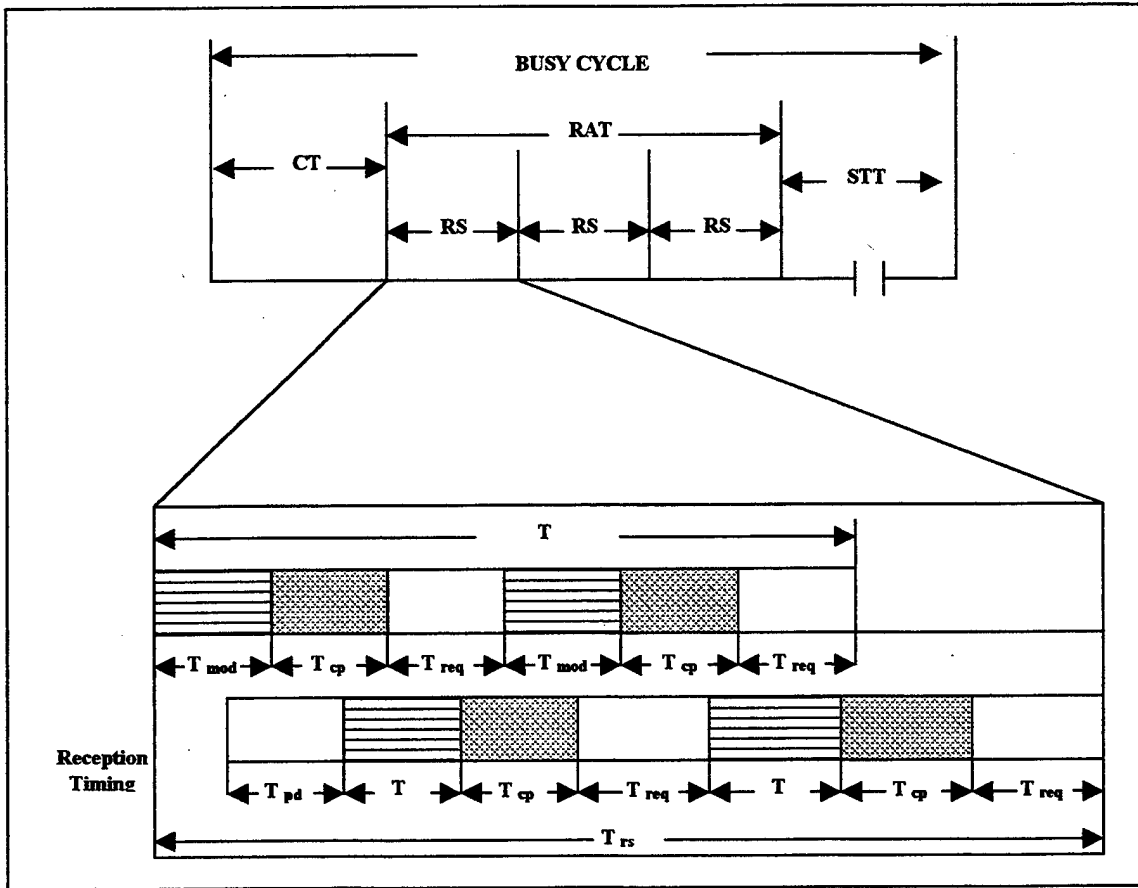

Where T_{mod} , T_{cp} , T_{req} , T_{pd} , N , T_{xmit} , and T_{rs} are defined, in seconds, as follows:

KG-84A	Baseband Rate (bps)	
	1200	2400
T_{mod} [modem preamble]	0.23	0.12
T_{cp} [KG-84A preamble + BISYNC code]	0.23	0.12
T_{req} [RR transmission time]	0.06	0.03
T_{pd} [propagation delay (± 0.01 sec)]	0.26	0.26
N [number of transmissions per cycle]	2	2
$T_{xmit} = N * (T_{cp} + T_{mod} + T_{req}) + T_{pd}$ [total xmit time]	1.46	1.31
T_{rs} [RS duration]	1.60	1.60

Figure 5-18. Non-DAMA Mode OTCIXS II Timing – RATS

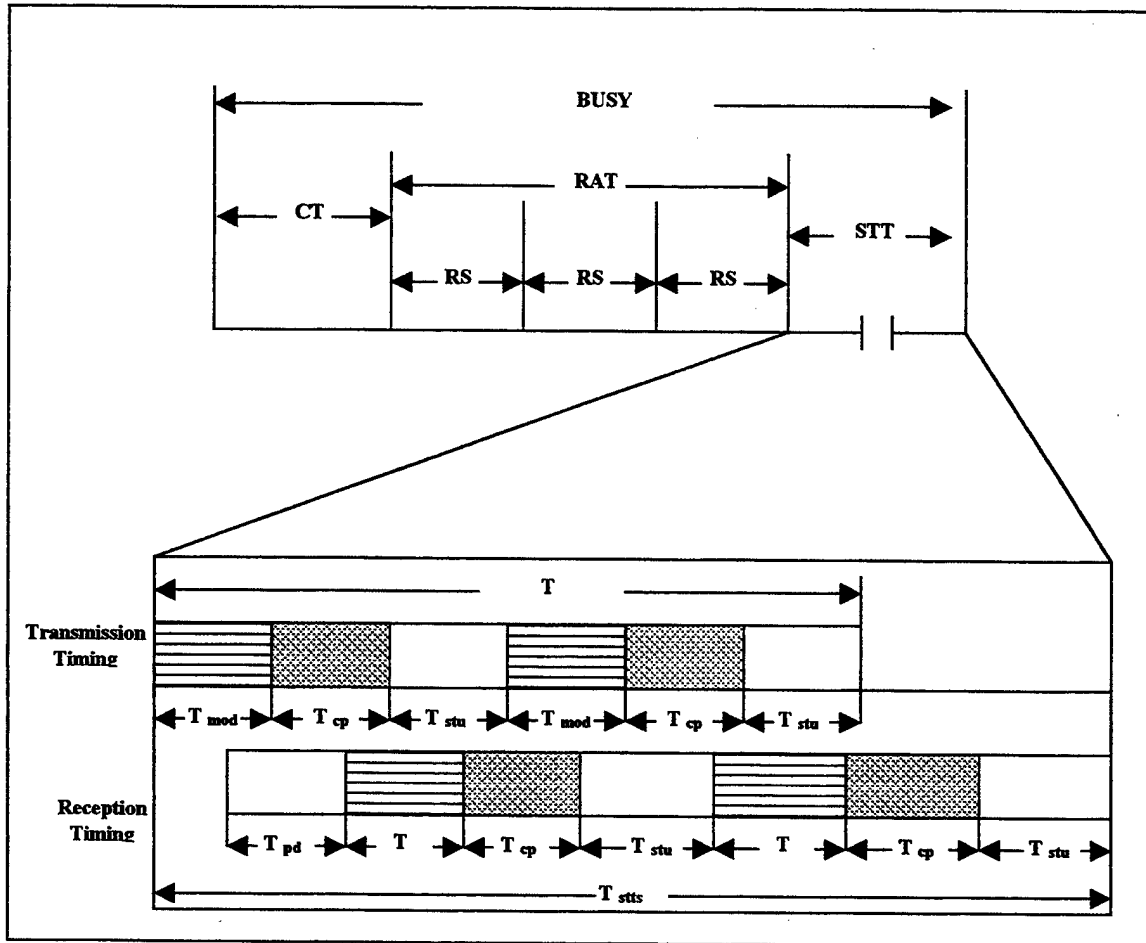

Where T_{cp} , T_{mod} , T_{stu} , T_{pd} , N , T_{xmit} , and T_{sts} are defined, in seconds, as follows:

KG-84A	Baseband Rate (bps)	
	1200	2400
T_{cp} [KG-84A preamble + BISYNC code]	0.16	0.08
T_{mod} [modem preamble]	0.10	0.10
T_{stu} [max length STU transmission time]	35.00	17.50
T_{pd} [propagation delay (± 0.01 sec)]	0.26	0.26
N [number of transmissions per cycle]	2	2
$T_{xmit} = N * (T_{cp} + T_{mod} + T_{stu}) + T_{pd}$ [total xmit time]	70.78	35.62
T_{sts} [STTS duration]	70.78	35.62

Figure 5-19. Non-DAMA Mode OTCIXS II Timing - STTS

broadcast time and as having a precedence level between Flash and Immediate thereafter.

The OTCIXS II network protocol is not influenced by the type of subscriber data exchanged over the link.

(1). SID of the NCS net member serving as NCS shall:

(a). Maintain the following control information, updating as necessary during net operations, and include it in the NCB it transmits to initiate each net cycle.

(2). Current network time

(3). SID of the net member, if any, that is authorized to transmit a STU in the STTS of the current net cycle and the number of times that STU is to be transmitted

(4). Number of Flash and Immediate RSs in the RATS of the current net cycle

(5). Type of service provided during the current net cycle, as follows:

(a). Nonscheduled transmission of Flash precedence STU

(b). Nonscheduled transmission of Immediate precedence STU

(c). Scheduled broadcast STU transmission

(d). No STU transmission

(6). Parameters to be used by net member in predicting service requirements

(7). Scheduled broadcasting status during the current net cycle, as follows:

- (a). Scheduled broadcast activity this cycle
- (b). Scheduled broadcast activity for this cycle delayed by Flash transmission
- (c). Scheduled broadcast activity for this cycle preempted
- (d). No scheduled broadcast activity this cycle
- (8). Acknowledgments for the last three STUs transmitted by net members
- (9). The list of RRs, previously submitted by net subscribers, that are awaiting service. This list, called the LAQ, contains a maximum of 21 RRs each consisting of:
 - (a). SID of the subscriber requesting authorization to transmit an STU
 - (b). Type of STU transmission to be performed
 - (1). Nonscheduled transmission of Flash precedence STU
 - (2). Nonscheduled transmission of Immediate precedence STU
 - (3). Scheduled broadcast STU transmission
 - (4). Predicted nonscheduled transmission of Immediate precedence STU
 - (c). Minute past the hour at which scheduled broadcast is to be performed (scheduled broadcast transmissions only)
 - (d). Number of times the subscriber has requested its STU be transmitted.

(b). Receive RRs from other net members and, following validation, queue and acknowledge those requests. RR validation shall consist of:

(1). Identifying the entity received as an RR by means of its CID value.

(2). Constructing error-free values for each item of critical information contained in the request. Each such item is triply encoded and its contents is considered valid when two out of the three decoded values are equal.

(c). Selectively authorize, on an FCFS within precedence basis, net members to transmit subscriber data, in STUs, on the net.

(d). Transmit subscriber data, in STUs, to other net members. The member providing the Net Control Function shall indicate a requirement to transmit an STU by creating an entry at the end of the LAQ, within precedence, rather than broadcasting via the satellite link.

(e). Receive subscriber data, in STUs, from other net members.

(f). Detect and report Dual NCS conditions indicated by reception of NCBs from another net member.

b. Subscriber.

Each OTCIXS II net member other than the one serving as NCS participates in the net as a subscriber only. In this role the net member shall:

a. Receive NCBs sent by the NCS to initiate net cycles. In so doing, the net member shall:

(1). Maintain net cycle synchronization

(2). Detect and report changes in the NCS SID and net initial-

ization sequences

(3). Detect and report the absence of Net Control if more than 76 seconds elapse without receipt of a recognizable NCB or STU

(4). Determine when it is permitted to transmit RRs or subscriber data

(5). Receive system time from the NCS and, when validated, update its time accordingly

(6). Receive NCS acknowledgments for previously submitted RRs

(7). Maintain the current contents of the LAQ.

(b). Receive subscriber data, in STUs, from other net members in STUs

(c). Transmit RRs to NCS

(d). Transmit subscriber data, in STUs, to other net members when specifically authorized by NCS to do so.

2. Initialization/Startup.

Whenever a net startup occurs, the NCS shall initiate an Extended RATS. As illustrated in Figure 5-20, the Extended RATS consists of eight consecutive idle cycles, each having an eight RS RATS. During the Extended RATS, any slot may be used for the transmission of RRs without regard to the precedence of the traffic to be transmitted.

On net initialization, the first cycle's NCB shall have a RATS TYPE field value of one and specify an eight RS RATS. Net members requiring net services shall transmit RRs in the Extended RATS as follows:

a. The net cycle, in the Extended RATS, in which to transmit shall be determined by random selection.

b. The RS, in the previously identified net cycle, in which to transmit shall be determined by random selection.

3. RATS Management.

The RATS portion of the OTCIXS II net cycle supports the submission of RRs to the NCS by net subscribers. Except as discussed under initialization/startup, the RATS for a net cycle shall contain three RSs: RS1, RS2, and RS3. NCS shall designate each of these slots as a Flash Slot, reserved for Flash precedence RRs, or an Immediate Slot, reserved for Immediate precedence and Scheduled Broadcast RRs. To support NCS reception of Flash precedence requests prior to Immediate precedence requests, RSs designated as Flash Slots shall occur, in the RATS, prior to those designated as Immediate Slots. NCS designation of RSs shall be based on the type of activity that is to take place during that cycle:

a. During a busy net cycle in which Flash traffic is to be transmitted in the STTS, there shall be two Flash Slots and one Immediate Slot.

b. During a busy net cycle in which Immediate traffic is to be transmitted in the STTS, there shall be one Flash Slot and two Immediate Slots.

c. During an idle net cycle, there shall be one Flash Slot and two Immediate Slots.

The number of Flash Slots and Immediate Slots in a net cycle is indicated in the NCB sent by the NCS to initiate that cycle.

4. Link Access Request Submission.

The following subparagraphs provide details of the techniques used by net members to submit their transmission requirements to the NCS.

a. RRTU.

A net member not authorized to transmit during the current net cycle's STTS shall initiate a request for link access by transmitting an RRTU in an RS of the RATS in a single OTCIXS II data link layer packet. A net member with Flash precedence traffic to transmit shall use a Flash Slot to identify its transmission requirements to the NCS. If more than one Flash Slot is available, the net member shall randomly select one. A net member with Immediate precedence or scheduled broadcast traffic to transmit shall use an Immediate Slot to identify its transmission requirements to the NCS. If more than one Immediate Slot is available, the net member shall randomly select one. A net member with traffic to transmit shall not transmit an RRTU if:

1. An RR for nonscheduled STU transmission at the same precedence level previously submitted by that member is present in the LAQ

2. The net member is currently executing the CRA described in paragraph 6.3.6.

member is awaiting service with respect to a previously sent RR for Immediate traffic.

b. Piggyback RR.

A net member authorized to transmit during the current net cycle's STTS may indicate one additional request for link access by piggybacking an RR in space provided in the STU format. By doing so, the net member may submit its request without risk of contention with other members. In this way it is possible for a net member to request and be granted authorization to transmit STUs on a continuing basis. Piggyback requests may result from existing or predicted service requirements and can be used even if the net member is. A net member may, however, submit an RR for Flash traffic even though that currently executing the CRA described in paragraph C.6

(1). Existing Service Requirements. An existing service requirement shall exist when the net member granted authorization to transmit a STU:

(a). Has more messages than a single STU can accommodate. In this case, the net member may use the STU's piggyback request structure to indicate:

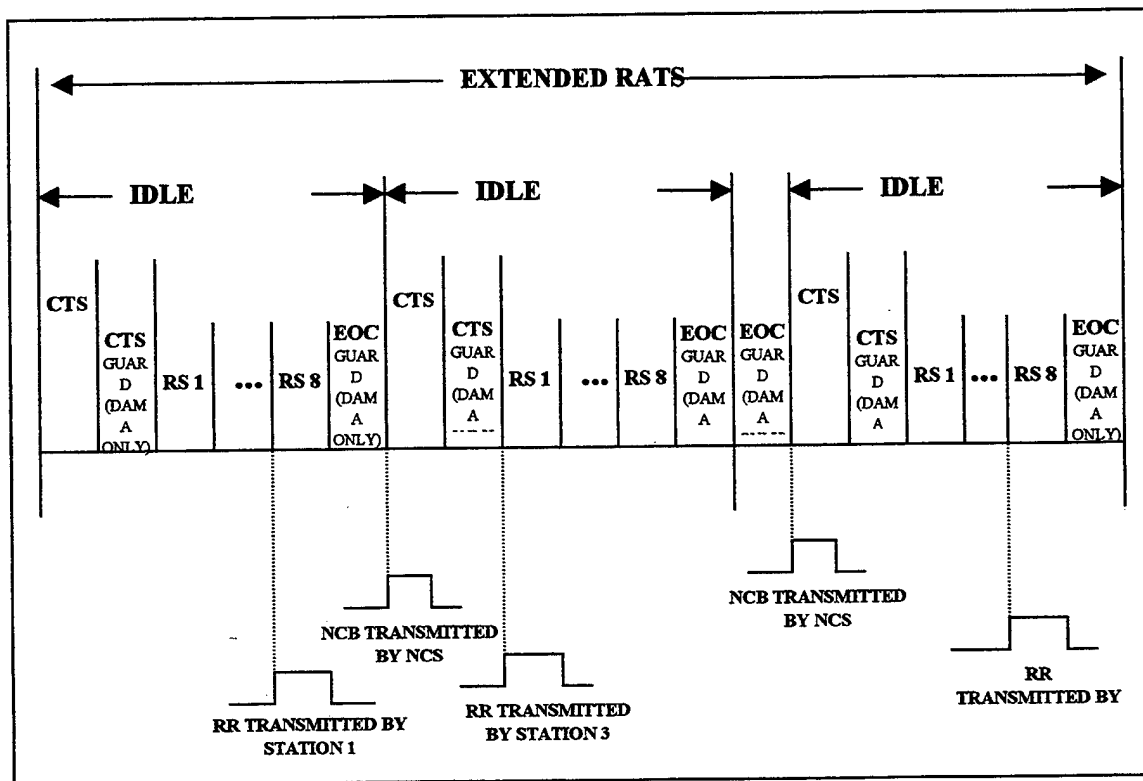

Figure 5-20. Extended RATS Structure and Use

NOTES:

1. Each "transmission" shown may involve multiple physical transmissions -each preceded by all required preambles. The number of physical transmissions to be performed is dependent on the selected net operating mode (DAMA\Non-DAMA) and baseband data rate as shown in Table 5-1.
2. NCS transmits a NCB in the CTS to initiate the first cycle of the extended RATS. The RATS TYPE field of this NCB field indicates "Initial Net Cycle of Extended RATS."
3. Station 1 determines that it has an STU to send, randomly selects Cycle 1 of the Extended RATS, and then randomly selects RS8 of the cycle. Since Cycle 1 of the Extended RATS was selected, station 1 sends an RRTU in RS8 of the RATS of the current net cycle.
4. Station 3 determines that is has an STU to send, randomly selects Cycle 2 of the Extended RATS, and then randomly selects RS1 of that cycle. Station 3 now awaits for reception of the NCB initiating the second cycle of the Extended RATS and sends an RRTU in RS1 of the RATS of the net cycle.

5. Station 2 determines that it has an STU to send, randomly selects Cycle 8 of the Extended RATS, and then randomly selects RS8 of that cycle. Station 2 now waits for reception of the NCB initiating the eighth cycle of the Extended RATS and sends an RRTU in RS8 of the RATS of that net cycle.

(1). Additional transmission required for nonscheduled broadcast.

(2). Additional transmission required for the current scheduled broadcast.

This request will be queued for service exactly like any other request and, as a result, consecutive cycle allocations cannot be guaranteed.

(b). Identifies the next time at which a STU is to be delivered by scheduled broadcast.

(2). Predicted Service Requirements. A predicted service requirement shall exist when the net member granted authorization to transmit a STU predicts that an additional nonscheduled broadcast transmission requirement is likely to exist in the near future. This prediction is based on the number of messages that became available for transmission by that net member during the preceding net cycles. If at least one message became available for transmission by the net member in at least M of the immediately preceding N net cycles, that net member shall use the STU's piggyback request structure to indicate a predicted service requirement. Values of M and N to be used by the net members in their service requirement predictions are provided by the NCS in the HIT and WINDOW fields, respectively, of each NCB. If M=2 and N=16, for example, a predicted service requirement would exist if at least one message became available for transmission by the net member during 2 or more of the preceding 16 net cycles.

5. Link Access Request Reception.

To receive RR forwarded by net members, the NCS shall copy all RRTUs transmitted during the RATS and, for the purpose of identifying piggyback RRs, all STUs transmitted during the STTS. RRs shall be validated and processed based on the type of service requested. As previously indicated, the LAQ shall contain up to 21 entries each indicating an RR, previously submitted by a net member, that is awaiting service. Of these entries, 19 shall be used for RRs without regard to service type requested. While these 19 entries are full, the NCS shall discard RRs that do not indicate nonscheduled transmission of Flash precedence STU. Two entries in the LAQ shall be reserved exclusively for RRs indicating nonscheduled transmission of Flash precedence STU.

Each RR made by a net member shall be acknowledged by NCS through inclusion of the net member's SID in the LAQ which is provided in the NCB. If a net member does not observe its SID in the LAQ in the next NCB, the request collided with a request submitted by another net member in the same RS or no entries in the LAQ were available to support the type of service requested. In either event, the net member shall execute the CRA described in paragraph 6.3.6.

a. Nonscheduled Transmission of Flash Precedence STU.

If an RR indicating a requirement for nonscheduled transmission of a Flash precedence STU is received, the NCS shall examine the LAQ for the net member submitting the request to determine if an entry for that member currently exists. If one does not exist, an entry shall be created that contains the newly received RR. If an entry already exists and that entry indicates:

1. Nonscheduled transmission of Flash precedence STU, the NCS shall

discard the newly received RR as a duplicate.

2. Scheduled Broadcast STU transmission, the NCS shall create an entry for the newly received RR.

If the RR was submitted by piggyback and indicated a predicted service requirement, the NCS shall delay entering the request in the LAQ for one net cycle. This delay improves the likelihood that the subscriber predicting a service requirement will have a message ready for transmission when the NCS selects the request from the LAQ.

b. Nonscheduled Transmission of Immediate Precedence STU.

If an RR indicating a requirement for nonscheduled transmission of an Immediate precedence STU is received, the NCS shall examine the LAQ for the net member submitting the request to determine if an entry for that member currently exists. If one does not exist, an entry shall be created that contains the newly received RR. If an entry already exists and that entry indicates:

1. Nonscheduled transmission of Immediate precedence STU, the NCS shall discard the newly received RR as a duplicate.

2. Scheduled Broadcast STU transmission, the NCS shall create an entry for the newly received RR. If the RR was submitted by piggyback and indicated a predicted service requirement, the NCS shall delay entering the request in the LAQ for one net cycle. This delay improves the likelihood that the subscriber predicting a service requirement will have a message ready for transmission when the NCS selects the request from the LAQ.

c. Scheduled Broadcast STU Transmission STU.

If an RR indicating a requirement for scheduled broadcast STU

transmission is received, the NCS shall examine the LAQ for the net member submitting the request to determine if a scheduled broadcast entry for that member already exists. If an entry already exists, the broadcast minute from the new request shall replace the broadcast minute of the LAQ entry. If an entry does not exist, the NCS shall create an entry in the LAQ for the newly received Scheduled Broadcast request.

6. Contention Resolution Algorithm.

When more than one net member transmits an RR in the same RS, the resulting collision is referred to as contention for that given RS. When a net member transmitting an RR fails to locate its SID in the LAQ included in the next cycle's NCB, contention has occurred and that net member must execute a CRA. The CRA consists of randomly selecting the number of net cycles the member must delay prior to retransmitting the RR. For RRs involving nonscheduled transmission of Flash precedence STU, the range of cycles to delay shall be 0-7 cycles. For all other RRs, the range of cycles to delay shall be 0-15. If the net member is granted authorization to transmit an STU prior to completion of the CRA, the CRA shall be terminated if the net member is able to piggyback the RR involved to that STU.

7. Link Access Request Servicing.

Prior to the initiation of each net cycle, the NCS shall examine the contents of its LAQ to identify if any RRs are awaiting service. If not, the NCB sent by the NCS to initiate the next net cycle shall indicate an idle cycle with no STU transmission and mark the scheduled broadcast status as not active. In addition, the contents of the GSID field of that NCB shall indicate that no net member has been authorized to transmit in the STTS.

If at least one RR is present, NCS shall:

- a. Examine each RR in the LAQ requesting scheduled broadcast STU transmission. NCS shall:
1. Purge those that were not serviced within 45 seconds of their indicated transmission time and mark the scheduled broadcast status of the next net cycle as preempted by Flash traffic.
 2. Mark as available for servicing any such request whose indicated transmission time has just arrived.
- b. Attempt to service a Flash request. If at least one is present, the NCS shall mark the next net cycle as nonscheduled transmission of Flash precedence STU and select the Flash request that has been in queue the longest for service. The NCS shall identify the net member submitting that request as authorized to transmit in the STTS of the next net cycle and purge the request from the LAQ. If at least one scheduled broadcast request is marked as available for servicing, the NCS shall mark the scheduled broadcast status of the next cycle as delayed by Flash traffic. If not, the NCS will mark the scheduled broadcast status of the next cycle as not active.
- c. If no Flash requests are present, attempt to service a scheduled broadcast request. If at least one is present that is marked as available for servicing, the NCS shall mark the next net cycle as scheduled broadcast STU transmission and select the scheduled broadcast request that has been in queue the longest for service. The NCS shall identify the net member submitting that request as authorized to transmit in the STTS of the next net cycle and purge the request from the LAQ. The NCS shall also mark the scheduled broadcast status of the next net cycle as active.
- d. If no Flash requests or scheduled broadcast requests marked as available for

servicing are present, attempt to service an Immediate request. If at least one is present, the NCS shall mark the next net cycle as nonscheduled transmission of Immediate precedence STU and select the Immediate request that has been in queue the longest for service. The NCS shall identify the net member submitting that request as authorized to transmit in the STTS of the next net cycle and purge the request from the LAQ. The NCS shall also mark the scheduled broadcast status of the next net cycle as not active.

e. If no request can be serviced this net cycle, mark the next net cycle as an idle cycle with no STU transmission and mark the scheduled broadcast status as not active. In addition, the NCS shall indicate that no net member has been authorized to transmit in the STTS of the next net cycle.

The NCS shall allocate exactly one STTS per RR. The NCB initiating a busy net cycle shall identify the net member to whom the STTS is allocated, the number of times the STU will be transmitted, the type of service provided during the net cycle, and the status of scheduled broadcasting during the net cycle. Only that net member to whom the cycle is allocated shall be permitted to transmit in the STTS and the sequence of transmissions, once begun, cannot be preempted.

8. Subscriber Data Transmission.

When a net member receives an NCB identifying its SID as the authorized transmitter during the STTS of the current net cycle, the net member shall compose its STU and commence transmission of that STU within 2 seconds of the onset of the STTS.

STU composition and transmission shall be performed as follows:

a. The net member shall determine the type of transmission being authorized during this net cycle from the MODE field of the NCB initiating the cycle.

b. If no Transport Layer messages are available for transmission, an empty STU shall be composed and transmitted.

c. The net member shall determine which of the Transport Layer messages available for transmission are to be included in this STU as follows,

1. Flash precedence STU transmission authorized. Flash precedence messages shall be selected for inclusion on a FIFO basis. Message selection shall continue until all Flash precedence messages have been selected or the space available in the STU for conveying Network messages has been exhausted.

2. Immediate precedence STU transmission authorized. Message selection shall depend on whether any Flash precedence messages are available for transmission, as follows:

(a). Flash precedence messages available. Flash precedence messages shall be selected for inclusion on a FIFO basis. Message selection shall continue until all Flash precedence messages have been selected or the space available in the STU for conveying Network messages has been exhausted. An RR shall be piggybacked in the STU to re-request transmission authorization for the Immediate precedence messages whose transmission was deferred.

(b). Flash precedence messages not available. Immediate precedence messages shall be selected for inclusion on a FIFO basis. Message selection shall continue until all Immediate precedence messages have been selected or the space available in the STU for conveying Network messages has been exhausted.

d. Each Transport Layer message selected for inclusion in the STU shall be incorporated into a Network message and a BSN shall be assigned to that message for

identification. BSNs shall be assigned sequentially to support link accountability and identification of missed messages.

e. The Network messages resulting from the preceding step shall be assembled into the STU. A Message Pointer Block shall be constructed to define, explicitly, the starting positions of each Network message in the STU. Due to the critical nature of its contents, the Message Pointer Block shall be terminated by a PCS. The PCS shall be a CRC sequence calculated as described in Appendix B.

Net members receiving this STU shall use the PCS to validate the contents of the Message Pointer Block and, as a result, their ability to delimit the Network messages in the STU properly.

f. If an existing or predicted service requirement exists, the net member shall piggyback an RR to the STU. To accomplish this, the RESV field of the STU shall indicate the presence of such a requirement. The MODE field shall identify the type of service request being piggybacked to this STU, and the XMIT CT field shall indicate the number of times the STU in the piggybacked RR is to be broadcast. If the requested service is scheduled broadcast STU transmission, the TRANSMIT MINUTE shall indicate the minute within the hour at which the scheduled broadcast is to occur.

g. The MORE field of the STU shall indicate a requirement for additional net services under the current broadcast if:

1. The STU under construction is to be transmitted by scheduled broadcast
2. More messages are available for transmission on the broadcast than can be accommodated in a single STU

3. The total amount of transmit time on the scheduled broadcast, including the services being indicated in this request, will not exceed five minutes.

h. The STU shall be forwarded to the Data Link Layer for decomposition into a series of 100-byte data link packets and transmission via the assigned satellite channel. The STU shall be transmitted in its entirety and, in most instances, transmitted up to two more times in succession in this net cycle; the actual number of repeats is an operator-selectable option. The COPY field in each transmission shall uniquely identify each transmission of the STU in the STTS.

A special situation arises when the station transmitting a STU is also the designated NCS. In such instances, the NCS shall delay at least 500 milliseconds before initiating the next net cycle to accommodate uplink/downlink propagation and provide time for net members to finalize the STU reception process and prepare to receive the next cycle's NCB.

9. Subscriber Data Reception.

Each net member, including NCS, copying the downlink STTS broadcast shall attempt to reconstruct an error-free composite copy of the STU from the incoming packet stream using selective packet replacement when more than one transmission of the STU in the STTS has been performed. As soon as an error-free composite copy has been constructed or all transmissions of the STU have been received, processing of the STU shall commence as described in the following subparagraphs.

a. Subscriber.

Each member participating in the net as a subscriber shall:

1. Attempt to validate the triply encoded CID and SID fields of the STU.

Since the CID field of the STU identifies the type, and hence structure, of the received TU, the received STU shall be discarded if the CID field cannot be validated. If validation of the SID field is achieved and the SID is equal to the receiver's SID, a Dual SID alert shall be generated.

2. Attempt to validate the contents of the Message Pointer Block in the STU by calculating a CRC on its fields, exclusive of the PCS field, and comparing it to the contents of the PCS field. The algorithm used to calculate this CRC is described in Appendix B. If a match is not obtained, the STU shall be discarded since the individual network messages in the STU cannot be properly delimited.

3. If the contents of the Message Pointer Block is valid, each network message in the STU shall be extracted and forwarded to the Transport Layer.

b. Net Control Station.

In addition to performing all processing required for the Subscriber participation mode, the member serving as the NCS shall acknowledge receipt of the STU, Attempt to allocate additional net cycles to net members performing scheduled broadcast STU transmission when necessary to complete that broadcast and identify and process an RR piggybacked to the STU.

(1). STU Acknowledgment. To acknowledge receipt of an STU via the downlink broadcast, the NCS shall update its control information as follows:

(a). The SID of the net member shown in the STU 3 Acknowledge field of the NCB transmitted in the preceding net cycle shall be discarded.

(b). The SID of the net member shown in the STU 2 Acknowledge field of the NCB transmitted in the preceding net cycle shall be placed in the STU 3

Acknowledge field of the next NCB to be sent.

(c). The SID of the net member shown in the STU 1 Acknowledge field of the NCB transmitted in the preceding net cycle shall be placed in the STU 2 Acknowledge field of the next NCB to be sent.

(d). The SID of the net member transmitting the received STU shall be placed in the STU 1 Acknowledge field of the next NCB to be sent. If the SID field of the received STU could not be validated, the STU 1 Acknowledge field will indicate that no subscriber is being acknowledged.

(2). Scheduled Broadcast Continuation. If the received STU was transmitted by scheduled broadcast and the MORE field of the STU indicates that additional service is required for STU transmission on the current broadcast schedule, the NCS shall examine its LAQ and:

(a). If no Flash precedence RRs are present and if less than 5 minutes (maximum) have elapsed since the onset of the first net cycle allocated to this scheduled broadcast. The NCS shall authorize the net member indicated in the SID field to continue the scheduled broadcast in the next net cycle. NCS shall indicate this authorization by using the net member's SID in the GSID field in the next NCB to be sent.

(b). If a Flash precedence RR is present or if more than 5 minutes have elapsed since the onset of the first net cycle allocated to this scheduled broadcast, the NCS shall reject the request for scheduled broadcast continuation. The NCS shall notify the requesting net member of the rejection by setting the SB STATUS field in the next NCB to be sent to indicate that scheduled broadcasting has been preempted. In addition, net members monitoring the scheduled broadcast shall determine from the preemption

indication that the scheduled broadcast has ended.

(3). Piggyback Request Identification. To support submission of RRs via STU piggyback, the NCS shall:

(a). If the SID field of the STU could not be validated, discontinue processing of the STU for purposes of identifying piggybacked service requests.

(b). When the criteria described in paragraph C.9.2.2 are met, support continuation of a net member's scheduled broadcast.

(c). If the RESV field indicates the presence of a piggybacked RR, attempt to validate the triply encoded MODE, TRANSMIT MINUTE, and XMIT CT fields of the STU. Since these fields identify the characteristics of the requested net service, processing of the STU for purposes of identifying piggybacked service requests shall be discontinued if any of these fields cannot be validated. If these fields are validated, the RR shall be added to the LAQ as discussed in the Link Access Request Reception description.

10. Transfer of NCS Responsibilities.

The OTCIXS II protocol contains no provisions for transferring NCS responsibilities automatically. The role of NCS is assumed or relinquished on operator command under direction of Fleet and Theater commanders. Each net member capable of assuming the role of NCS copies and maintains the current LAQ sent by the current NCS in each received NCB. This process provides the necessary information to each net member to enable that member to assume the role of NCS and resume net operations without performing the regular net initialization sequence.

THIS PAGE INTENTIONALLY LEFT BLANK

VI. DATA UNIT DESCRIPTIONS

A. GENERAL.

This section provides a detailed description of the content and format of the signals exchanged between OTCIXS II subscribers. Each description consists of a figure, pictorially representing the position of the various fields, followed by a table explaining and clarifying each field. All numbers are in hexadecimal unless specified otherwise. Legal values are identified for each field which does not permit the full range of legal values represented by the field. Fields which do not include the identification of legal values can contain any value which can be represented by the field size (i.e., a byte can contain values 0 through FF).

B. DATA UNIT DESCRIPTION - NET CONTROL STATION TO SUBSCRIBER.

Table 6-1 summarizes the data units transferred from the OTCIXS II NCS and an OTCIXS II subscriber.

Table 6-1. Net Control Station to Subscriber Data Unit Summary

DATA UNIT NAME	COMPONENT ID	FIGURE
Net Control Block (NCB) Transmission Unit (TU)	B	6-1
Subscriber Transmission Unit (STU)	D	6-3
Network Message	-	6-4
Data Link Layer Packet	-	6-5

C. DATA UNIT DESCRIPTION - SUBSCRIBER TO NET CONTROL STATION.

Table 6-2 summarizes the data units transferred from an OTCIXS II subscriber to the OTCIXS II NCS.

Table 6-2. Subscriber to Net Control Station Data Unit Summary

DATA UNIT NAME	COMPONENT ID	FIGURE
Reservation Request (RR) Transmission Unit (RRTU)	C	6-2
Subscriber Transmission Unit (STU)	D	6-3
Network Message	-	6-4
Data Link Layer Packet	-	6-5

D. DATA UNIT DESCRIPTION - SUBSCRIBER TO SUBSCRIBER.

Table 6-3 summarizes the data units transferred from one OTCIXS II subscriber to another OTCIXS II subscriber.

Table 6-3. Subscriber to Subscriber Data Unit Summary

DATA UNIT NAME	COMPONENT ID	FIGURE
Subscriber Transmission Unit (STU)	D	6-3
Network Message	-	6-4
Data Link Layer Packet	-	6-5

B Y T E	BIT POSITIONS							
	7	6	5	4	3	2	1	0
0	CID				COPY		RATS TYPE	
1	CID				COPY		RATS TYPE	
2	CID @ 5				COPY @ 1		RATS TYPE @ 1	
3	NCS SID (LSB)							
4	NCS SID (LSB)							
5	NCS SID (LSB) @ 55							
6	N/U	NCS SID (MSB)						
7	N/U	NCS SID (MSB)						
8	N/U	NCS SID (MSB) @ 15						
9	N/U			HOURS				
A	N/U	MINUTES						
B	N/U	SECONDS						
C	TIME CHECKSUM							
D	GRANTED SID (GSID) (LSB)							
E	GRANTED SID (GSID) (LSB)							
F	GRANTED SID (GSID) (LSB) @ 55							
10	N/U	GRANTED SID (GSID) (MSB)						
11	N/U	GRANTED SID (GSID) (MSB)						
12	N/U	GRANTED SID (GSID) (MSB) @ 15						
13	XMIT CT	FLASH SLOTS			IMMEDIATE SLOTS			
14	XMIT CT	FLASH SLOTS			IMMEDIATE SLOTS			
15	XMIT CT @ 1	FLASH SLOTS @ 2			IMMEDIATE SLOTS @ 5			
16	MODE	SB STATUS		HITS		WINDOW SIZE		
17	MODE	SB STATUS		HITS		WINDOW SIZE		
18	MODE @ 1	SB STATUS @ 1		HITS @ 1		WINDOW SIZE @ 1		

Figure 6-1. Net Control Block (NCB) Transmission Unit

B Y T E	B I T P O S I T I O N							
	7	6	5	4	3	2	1	0
19	STU 1 ACKNOWLEDGE (LSB)							
1A	N/U		STU 1 ACKNOWLEDGE (MSB)					
1B	STU 2 ACKNOWLEDGE (LSB)							
1C	N/U		STU 2 ACKNOWLEDGE (MSB)					
1D	STU 3 ACKNOWLEDGE (LSB)							
1E	N/U		STU 3 ACKNOWLEDGE (MSB)					
1F	NCS LAQ SIZE							
20	NCS LAQ (see description)							
o								
o								
o								
N								

BYTE	FIELD	DESCRIPTION
0 (bits 0-1)	RATS TYPE	Identifies the type of RATS supported in this net cycle as follows: 0 - Normal RATS 1 - Initial net cycle of extended RATS 2 - Intermediate net cycle of extended RATS 3 - Final net cycle of extended RATS
0 (bits 2-3)	COPY	Indicates which copy of the NCB has been received; i.e., 1 is the first transmission, 2 is the second transmission. Legal values are 1 through 2.
0 (bits 4-7)	CID	Indicates the NCB data unit. Value is always hexadecimal B.
1 (bits 0-1)	<u> </u> RATS TYPE	One's complement of the RATS TYPE field.
1 (bits 2-3)	<u> </u> COPY	One's complement of the COPY field.

Figure 6-1. Net Control Block (NCB) Transmission Unit (cont.)

BYTE	FIELD	DESCRIPTION
1 (bits 4-7)	$\overline{\text{CID}}$	One's complement of the CID field.
2 (bits 0-1)	RATS TYPE @ 1	Exclusive OR of the RATS TYPE field with 1.
2 (bits 2-3)	COPY @ 1	Exclusive OR of the COPY field with 1.
2 (bits 4-7)	CID @ 5	Exclusive OR of the CID field with 5.
3	NCS SID (LSB)	Contains the LSB of the Net Control Station (NCS) ID. Legal values of NCS SID are 0001 through 9999 (decimal).
4	$\overline{\text{NCS SID (LSB)}}$	One's complement of the NCS SID (LSB) field.
5	NCS SID (LSB) @ 55	Exclusive OR of the NCS SID (LSB) field with hexadecimal 55.
6 (bits 0-5)	NCS SID (MSB)	Contains the MSB of the Net Control Station (NCS) ID. Legal values of NCS SID are 0001 through 9999 (decimal).
7 (bits 0-5)	$\overline{\text{NCS SID (MSB)}}$	One's complement of the NCS SID (MSB) field.
8 (bits 0-5)	NCS SID (MSB) @ 15	Exclusive OR of the NCS SID (MSB) field with hexadecimal 15.
9 (bits 0-4)	HOURS	Hour component of the current time as maintained by NCS. Legal values are 0 through 23 (decimal).
A (bits 0-5)	MINUTES	Minute component of the current time as maintained by NCS. Legal values are 0 through 59 (decimal).
B (bits 0-5)	SECONDS	Second component of the current time as maintained by NCS. Legal values are 0 through 59 (decimal).
C	TIME CHECKSUM	The least significant bits of the one's complement of the checksum of the HOURS, MINUTES, and SECONDS fields. Compute as: $\overline{(((\text{SECONDS} + \text{MINUTES}) \times 2) + \text{HOURS}) \times 2}$

Figure 6-1. Net Control Block (NCB) Transmission Unit (cont.)

BYTE	FIELD	DESCRIPTION
D	GSID (LSB)	Contains the LSB of the SID of the subscriber that has been granted the next STTS. Values of 0001 through 9999 identify a subscriber. A value of zero indicates that no subscriber has been assigned the STTS.
E	GSID (LSB)	One's complement of the GSID (LSB) field.
F	GSID (LSB) @ 55	Exclusive OR of the GSID (LSB) field with hexadecimal 55.
10 (bits 0-5)	GSID (MSB)	Contains the MSB of the SID of the subscriber that has been granted the next STTS. Values of 0001 through 9999 identify a subscriber. A value of zero indicates that no subscriber has been assigned the STTS.
11 (bits 0-5)	GSID (MSB)	One's complement of the GSID (MSB) field.
12 bits 0-5)	GSID (MSB) @ 15	Exclusive OR of the GSID (MSB) field with hexadecimal 15.
13 (bits 0-5)	IMMEDIATE SLOTS	Indicates the number of Immediate RSs in the current net cycle. These slots follow all Flash precedence RSs in the RATS. This field is ignored except when the RATS TYPE field indicates Normal RATS.
13 (bits 0-2)	FLASH SLOTS	Indicates the number of Flash precedence RSs in the RATS of the current net cycle. These slots precede all Immediate precedence RSs in the RATS. This field is ignored except when the RATS TYPE field indicates Normal RATS.
13 (bits 6-7)	XMIT CT	Indicates the number of times the subscriber designated by the GSID field is to transmit a STU in the STTS. Value range is one through three. A value of zero is illegal and shall be treated as one.
14 (bits 0-2)	IMMEDIATE SLOTS	One's complement of the IMMEDIATE SLOTS field.
14 (bits 3-5)	FLASH SLOTS	One's complement of the FLASH SLOTS field.
14 (bits 6-7)	XMIT CT	One's complement of the XMIT CT field.

Figure 6-1. Net Control Block (NCB) Transmission Unit (cont.)

BYTE	FIELD	DESCRIPTION
15 (bits 0-2)	IMMEDIATE SLOTS @ 5	Exclusive OR of the IMMEDIATE SLOTS field with hexadecimal 5.
15 (bits 3-5)	FLASH SLOTS @ 2	Exclusive OR of the FLASH SLOTS field with hexadecimal 2.
15 (bits 6-7)	XMIT CT @ 1	Exclusive OR of the XMIT CT field with 1.
16 (bits 0-1)	WINDOW SIZE	Identifies the size of the window, in net cycles, to be used by network subscribers in predicting their network service requirements. Legal values are as follows: 0 - 12 net cycles 1 - 16 net cycles 2 - 20 net cycles 3 - 24 net cycles
16 (bits 2-3)	HITS	Identifies the minimum number of net cycles, within the window specified by the WINDOW SIZE field, in which a net member must receive at least one message for transmission in order to predict a network service requirement. Legal values are as follows: 0 - 2 net cycles 1 - 3 net cycles 2 - 4 net cycles 3 - 5 net cycles
16 (bits 4-5)	SB STATUS	Indicates the scheduled broadcasting status during this net cycles as follows: 0 - Scheduled broadcast activity this cycle 1 - Scheduled broadcast activity for this cycle delayed by Flash transmission 2 - Scheduled broadcast activity for this cycle preempted 3 - No scheduled broadcast activity this cycle
16 (bits 6-7)	MODE	Identifies the type of service provided during this net cycle as follows: 0 - Nonscheduled transmission of Flash precedence STU 1 - Nonscheduled transmission of Immediate precedence STU 2 - Scheduled broadcast STU transmission 3 - No STU transmission

Figure 6-1. Net Control Block (NCB) Transmission Unit (cont.)

BYTE	FIELD	DESCRIPTION
17 (bits 0-1)	<u>WINDOW SIZE</u>	One's complement of the WINDOW SIZE field.
17 (bits 2-3)	<u>HITS</u>	One's complement of the HITS field.
17 (bits 4-5)	<u>SB STATUS @ 1</u>	One's complement of the SB STATUS field.
17 (bits 6-7)	<u>MODE</u>	One's complement of the MODE field.
18 (bits 0-1)	WINDOW SIZE @ 1	Exclusive OR of the WINDOW SIZE field with 1.
18 (bits 2-3)	HITS @ 1	Exclusive OR of the HITS field with 1.
18 (bits 4-5)	SB STATUS @ 1	Exclusive OR of the SB STATUS field with 1.
18 (bits 6-7)	MODE @ 1	Exclusive OR of the MODE field with 1.
19	STU 1 ACKNOWLEDGE DGE (LSB)	Contains the LSB of the SID of the subscriber that transmitted an STU one net cycle prior to this one. Indicates that NCS received the STU sent by that subscriber. Values of 0001 through 9999 (decimal) indicate the SID of the subscriber being acknowledged. A value of zero indicates that no subscriber is being acknowledged.
1A (bits 0-5)	STU 1 ACKNOWLEDGE DGE (MSB)	Contains the MSB of the SID of the subscriber that transmitted an STU one net cycle prior to this one. Indicates that NCS received the STU sent by that subscriber. Values of 0001 through 9999 (decimal) indicate the SID of the subscriber being acknowledged. A value of zero indicates that no subscriber is being acknowledged.
1B	STU 2 ACKNOWLEDGE DGE (LSB)	Contains the LSB of the SID of the subscriber that transmitted an STU two net cycles prior to this one. Indicates that NCS received the STU sent by that subscriber. Values of 0001 through 9999 (decimal) indicate the SID of the subscriber being acknowledged. A value of zero indicates that no subscriber is being acknowledged.

Figure 6-1. Net Control Block (NCB) Transmission Unit (cont.)

BYTE	FIELD	DESCRIPTION																																				
1C (bits 0-5)	STU 2 ACKNOWLEDGE DGE (MSB)	Contains the MSB of the SID of the subscriber that transmitted an STU two net cycles prior to this one. Indicates that NCS received the STU sent by that subscriber. Values of 0001 through 9999 (decimal) indicate the SID of the subscriber being acknowledged. A value of zero indicates that no subscriber is being acknowledged.																																				
1D	STU 3 ACKNOWLEDGE DGE (LSB)	Contains the LSB of the SID of the subscriber that transmitted an STU three net cycles prior to this one. Indicates that NCS received the STU sent by that subscriber. Values of 0001 through 9999 (decimal) indicate the SID of the subscriber being acknowledged. A value of zero indicates that no subscriber is being acknowledged.																																				
1E (bits 0-5)	STU 3 ACKNOWLEDGE DGE (MSB)	Contains the MSB of the SID of the subscriber that transmitted an STU three net cycles prior to this one. Indicates that NCS received the STU sent by that subscriber. Values of 0001 through 9999 (decimal) indicate the SID of the subscriber being acknowledged. A value of zero indicates that no subscriber is being acknowledged.																																				
1F	NCS LAQ SIZE	Indicates the number of subscribers that are awaiting assignment of link time for STU transmissions; that is, the number of entries in the LAQ. The queue can contain up to 21 (decimal) entries.																																				
20-K	NCS LAQ	The SIDs of the subscribers currently awaiting assignment of link time for STU transmissions. The length of this queue is given by the contents of the NCS LAQ SIZE field. Each entry in the NCS LAQ consists of three bytes defined as follows: <div style="text-align: center; margin-top: 10px;"> <table border="1" style="border-collapse: collapse; width: 100%;"> <tr> <td style="text-align: center;">B Y T E</td> <td style="text-align: center;">7</td> <td style="text-align: center;">6</td> <td style="text-align: center;">5</td> <td style="text-align: center;">4</td> <td style="text-align: center;">3</td> <td style="text-align: center;">2</td> <td style="text-align: center;">1</td> <td style="text-align: center;">0</td> </tr> <tr> <td style="text-align: center;">m</td> <td colspan="8" style="text-align: center;">SID (LSB)</td> </tr> <tr> <td style="text-align: center;">m+1</td> <td style="text-align: center;">MODE</td> <td colspan="7" style="text-align: center;">SID (MSB)</td> </tr> <tr> <td style="text-align: center;">m+2</td> <td style="text-align: center;">XMIT CT</td> <td colspan="7" style="text-align: center;">TRANSMIT MINUTE</td> </tr> </table> </div>	B Y T E	7	6	5	4	3	2	1	0	m	SID (LSB)								m+1	MODE	SID (MSB)							m+2	XMIT CT	TRANSMIT MINUTE						
B Y T E	7	6	5	4	3	2	1	0																														
m	SID (LSB)																																					
m+1	MODE	SID (MSB)																																				
m+2	XMIT CT	TRANSMIT MINUTE																																				

Figure 6-1. Net Control Block (NCB) Transmission Unit (cont.)

BYTE	FIELD	DESCRIPTION
20-K (cont.)	NCS LAQ (cont.)	<p>Where:</p> <p>SID (LSB) is the LSB of the subscriber SID</p> <p>SID (MSB) is the MSB of the subscriber SID. SIDs 0001 through 9999 (decimal) identify network subscribers.</p> <p>MODE identifies the type of entry as follows:</p> <ul style="list-style-type: none"> 0 - Nonscheduled transmission of Flash precedence STU 1 - Nonscheduled transmission of Immediate precedence STU 2 - Scheduled broadcast STU transmission 3 - Predicted nonscheduled transmission of Immediate precedence STU. <p>TRANSMIT MINUTE is the minute within the hour at which scheduled broadcast by this subscriber is to commence. Field is not interpreted when the MODE field of the queue entry indicates a nonscheduled broadcast.</p> <p>XMIT CT is the number of times the subscriber has requested its STU be broadcast. Range of values is one through three. A value of zero is illegal and shall be treated as one.</p>

Figure 6-1. Net Control Block (NCB) Transmission Unit (cont.)

B Y T E	B I T P O S I T I O N S							
	7	6	5	4	3	2	1	0
0	CID				COPY		N/U	
1	<u>CID</u>				<u>COPY</u>		N/U	
2	CID @ 5				COPY @ 1		N/U	
3	SID (LSB)							
4	<u>SID (LSB)</u>							
5	SID (LSB) @ 55							
6	MODE			SID (MSB)				
7	<u>MODE</u>			<u>SID (MSB)</u>				
8	MODE @ 1			SID (MSB) @ 15				
9	XMIT CT			TRANSMIT MINUTE				
A	<u>XMIT CT</u>			<u>TRANSMIT MINUTE</u>				
B	XMIT CT @ 1			TRANSMIT MINUTE @ 15				
C	RETRY COUNT							
D	<u>RETRY COUNT</u>							
E	RETRY COUNT @ 55							

BYTE	FIELD	DESCRIPTION
0 (bits 2-3)	COPY	Indicates which copy of the RR has been received; i.e., 1 is the first transmission, 2 is the second transmission. Legal values are 1 through 2.
0 (bits 4-7)	CID	Indicates the RR data unit. Value is always hexadecimal C.
1 (bits 2-3)	<u>COPY</u>	One's complement of the COPY field.
1 (bits 4-7)	<u>CID</u>	One's complement of the CID field.

Figure 6-2. Reservation Request (RR) Transmission Unit

BYTE	FIELD	DESCRIPTION
2 (bits 2-3)	COPY @ 1	Exclusive OR of the COPY field with 1.
2 (bits 4-7)	CID @ 5	Exclusive OR of the CID field with 5.
3	SID (LSB)	Contains the LSB of the SID of the network subscriber that is requesting service. Legal values are 0001 through 9999 (decimal).
4	<u>SID (LSB)</u>	One's complement of the SID (LSB) field.
5	SID (LSB) @ 55	Exclusive OR of the SID (LSB) field with hexadecimal 55.
6 (bits 0-5)	SID (MSB)	Contains the MSB of the SID of the network subscriber that is requesting service. Legal values are 0001 through 9999 (decimal).
6 (bits 6-7)	MODE	Indicates the type of service being requested as follows: 0 - Nonscheduled transmission of Flash precedence STU 1 - Nonscheduled transmission of Immediate precedence STU 2 - Scheduled broadcast transmission of STU 3 - N/U
7 (bits 0-5)	<u>SID (MSB)</u>	One's complement of the SID (MSB) field.
7 (bits 6-7)	<u>MODE</u>	One's complement of the MODE field.
8 (bits 0-5)	SID (MSB) @ 15	Exclusive OR of the SID (MSB) field with hexadecimal 15.
8 (bits 6-7)	MODE @ 1	Exclusive OR of the MODE field with 1.
9 (bits 0-5)	TRANSMIT MINUTE	Indicates the minute within the hour at which a scheduled broadcast is to occur. Field is not interpreted when the MODE field indicates a nonscheduled broadcast.

Figure 6-2. Reservation Request (RR) Transmission Unit (cont.)

BYTE	FIELD	DESCRIPTION
9 (bits 6-7)	XMIT CT	Indicates the requested number of times that the STU is to be broadcast. Range of legal values is one through three. A value of zero is illegal and shall be treated as one.
A (bits 0-5)	<u>TRANSMIT MINUTE</u>	One's complement of the TRANSMIT MINUTE field.
A (bits 6-7)	<u>XMIT CT</u>	One's complement of the XMIT CT field.
B (bits 0-5)	TRANSMIT MINUTE @ 15	Exclusive OR of the TRANSMIT MINUTE field with hexadecimal 15.
B (bits 6-7)	XMIT CT @ 1	Exclusive OR of the XMIT CT field with 1.
C	RETRY COUNT	Indicates the number of times the subscriber attempted net entry, prior to acknowledgement of the request in the NCB.
D	<u>RETRY COUNT</u>	One's complement of the RETRY COUNT field.
E	RETRY COUNT @ 55	Exclusive OR of the RETRY COUNT field with hexadecimal 55.

Figure 6-2. Reservation Request (RR) Transmission Unit (cont.)

B Y T E	B I T P O S I T I O N S							
	7	6	5	4	3	2	1	0
0	CID			COPY			PREC	RESV
1	<u>CID</u>			<u>COPY</u>			<u>PREC</u>	<u>RESV</u>
2	CID @ 5			COPY @ 1			PREC	RESV @ 1
3	SID (LSB)							
4	<u>SID (LSB)</u>							
5	SID (LSB) @ 55							
6	MODE		SID (MSB)					
7	<u>MODE</u>		<u>SID (MSB)</u>					
8	MODE @ 1		SID (MSB) @ 15					
9	XMIT CT		TRANSMIT MINUTE					
A	<u>XMIT CT</u>		<u>TRANSMIT MINUTE</u>					
B	XMIT CT @ 1		TRANSMIT MINUTE @ 15					
C	MORE	0	0	0	0	0	0	0
D	MORE	0	0	0	0	0	0	0
E	MORE	0	0	0	0	0	0	0
F	M E S S A G E P O I N T E R B L O C K (see description)							
0								
0								
N	N E T W O R K M E S S A G E 1							
M1								
0								
0	M2-1							
0								

Figure 6-3. Subscriber Transmission Unit

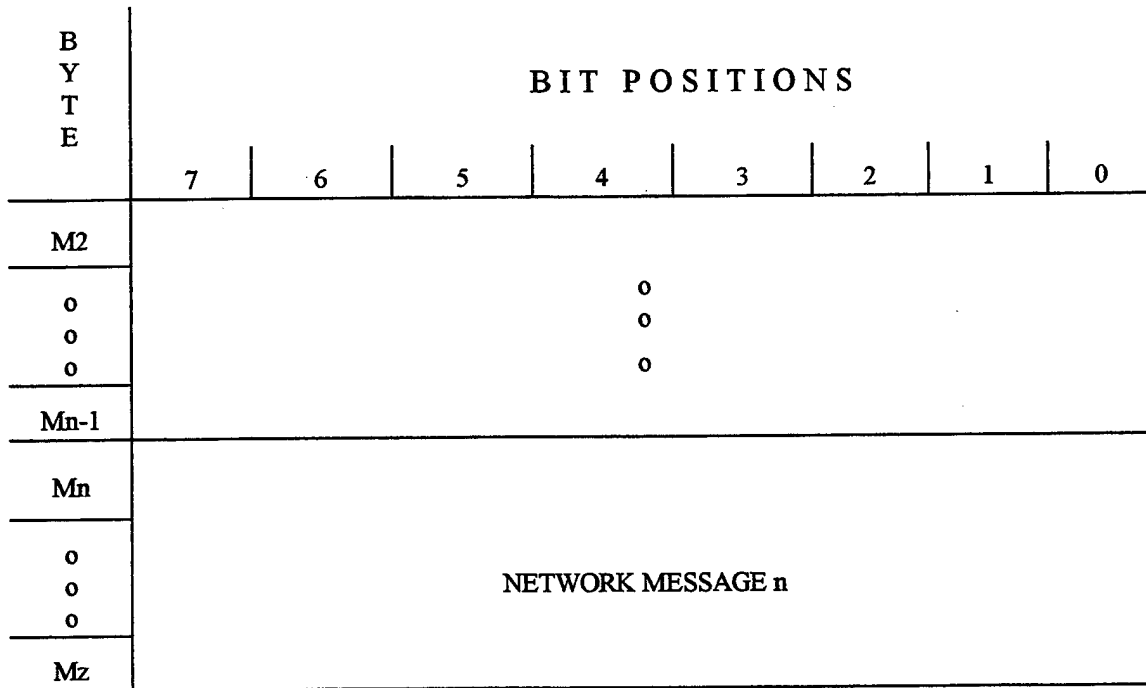

BYTE	FIELD	DESCRIPTION
0 (bit 0)	RESV	Indicates the presence or absence of a "piggy-back" reservation request in this STU. A value of one indicates a "piggy-back" reservation request is present; a value of zero indicates no such request is present.
0 (bit 1)	PREC	Indicates the precedence of the STU. A value of zero indicates an Immediate precedence STU. A value of one indicates a Flash precedence STU.
0 (bits 2-3)	COPY	Indicates which copy of the STU has been received; i.e., 1 is the first transmission, 2 is the second transmission, etc. Legal values are 1 through 3.
0 (bits 4-7)	CID	Indicates an STU. Value is always hexadecimal D.
1 (bit 0)	RESV	One's complement of the RESV field.
1 (bit 1)	PREC	One's complement of the PREC field.

Figure 6-3. Subscriber Transmission Unit (cont.)

BYTE	FIELD	DESCRIPTION
1 (bits 2-3)	<u> </u> COPY	One's complement of the COPY field.
1 (bits 4-7)	<u> </u> CID	One's complement of the CID field.
2 (bit 0)	RESV @ 1	Exclusive OR of the RESV field with 1.
2 (bit 1)	PREC	Duplicate of byte 0 (bit 1).
2 (bits 2-3)	COPY @ 1	Exclusive OR of the COPY field with 1.
2 (bits 4-7)	CID @ 5	Exclusive OR of the CID field with 5.
3	SID (LSB)	Contains the LSB of the SID of the network subscriber originating the transmission. Legal values are 0001 through 9999 (decimal).
4	<u> </u> SID (LSB)	One's complement of the SID (LSB) field.
5	SID (LSB) @ 55	Exclusive OR of the SID (LSB) field with hexadecimal 55.
6 (bits 0-5)	SID (MSB)	Contains the MSB of the SID of the network subscriber originating the transmission. Legal values are 0001 through 9999 (decimal).
6 (bits 6-7)	MODE	Indicates the type of service request that is "piggy-backed" to this STU as follows: 0 - Nonscheduled transmission of Flash precedence STU required 1 - Nonscheduled transmission of Immediate precedence STU required 2 - Scheduled broadcast transmission of STU required 3 - Nonscheduled transmission of Immediate precedence STU predicted This field is not interpreted when the RESV field indicates that no "piggy-back" reservation request is present.

Figure 6-3. Subscriber Transmission Unit (cont.)

BYTE	FIELD	DESCRIPTION
7 (bits 0-5)	<u> </u> SID (MSB)	One's complement of the SID (MSB) field.
7 (bits 6-7)	<u> </u> MODE	One's complement of the MODE field.
8 (bits 0-5)	SID (MSB) @ 15	Exclusive OR of the SID (MSB) field with hexadecimal 15.
8 (bits 6-7)	MODE @ 1	Exclusive OR of the MODE field with 1.
9 (bits 0-5)	TRANSMIT MINUTE	Indicates the minute within the hour at which a scheduled broadcast is to occur. This field is interpreted only when the RESV field indicate that a "piggy-back" reservation request is present and the MODE field indicates that Scheduled broadcast transmission of a STU is required.
9 (bits 6-7)	XMIT CT	Indicates the requested number of times the STU in the "piggy-back" reservation request is to be broadcast. Range of legal values is one through three. A value of zero is illegal and shall be treated as one.
A (bits 0-5)	<u> </u> TRANSMIT MINUTE	One's complement of the TRANSMIT MINUTE field.
A (bits 6-7)	<u> </u> XMIT CT	One's complement of the XMIT CT field.
B (bits 0-5)	TRANSMIT MINUTE @ 15	Exclusive OR of the TRANSMIT MINUTE field with hexadecimal 15.
B (bits 6-7)	XMIT CT @ 1	Exclusive OR of the XMIT CT field with 1.
C (bit 7)	MORE	Indicates if additional service is required for STU transmission on the current broadcast schedule. A value of one indicates service is required; a value of zero indicates no such requirement exists.
D (bit 7)	<u> </u> MORE	One's complement of the MORE field.

Figure 6-3. Subscriber Transmission Unit (cont.)

BYTE	FIELD	DESCRIPTION																																																																																																											
E (bit 7)	MORE	Duplicate of byte C (bit 7).																																																																																																											
F-N	MESSAGE POINTER BLOCK	<p>Indicates the location of the start of the messages in the STU. The block is formatted as follows:</p> <table border="1" style="margin-left: auto; margin-right: auto;"> <tr> <td rowspan="2" style="text-align: center; vertical-align: middle;">B Y T E</td> <td colspan="8" style="text-align: center;">BIT POSITIONS</td> </tr> <tr> <td style="text-align: center;">7</td> <td style="text-align: center;">6</td> <td style="text-align: center;">5</td> <td style="text-align: center;">4</td> <td style="text-align: center;">3</td> <td style="text-align: center;">2</td> <td style="text-align: center;">1</td> <td style="text-align: center;">0</td> </tr> <tr> <td style="text-align: center;">F</td> <td colspan="8" style="text-align: center;">MESSAGE COUNT</td> </tr> <tr> <td style="text-align: center;">10</td> <td colspan="8" style="text-align: center;">POINTER 1 (LSB)</td> </tr> <tr> <td style="text-align: center;">11</td> <td colspan="8" style="text-align: center;">POINTER 1 (MSB)</td> </tr> <tr> <td style="text-align: center;">o</td> <td colspan="8" style="text-align: center;">o</td> </tr> <tr> <td style="text-align: center;">o</td> <td colspan="8" style="text-align: center;">o</td> </tr> <tr> <td style="text-align: center;">o</td> <td colspan="8" style="text-align: center;">o</td> </tr> <tr> <td style="text-align: center;">N-3</td> <td colspan="8" style="text-align: center;">POINTER n (LSB)</td> </tr> <tr> <td style="text-align: center;">N-2</td> <td colspan="8" style="text-align: center;">POINTER n (MSB)</td> </tr> <tr> <td style="text-align: center;">N-1</td> <td colspan="8" style="text-align: center;">PCS (LSB)</td> </tr> <tr> <td style="text-align: center;">N</td> <td colspan="8" style="text-align: center;">PCS (MSB)</td> </tr> </table> <p>Where:</p> <p>MESSAGE COUNT is the number of network messages present in the STU.</p> <p>POINTER 1 (LSB) is the LSB of the location of the start of NETWORK MESSAGE 1 relative to the start of the MESSAGE POINTER BLOCK.</p> <p>POINTER 1(MSB) is the MSB of the location of the start of NETWORK MESSAGE 1 relative to the start of the MESSAGE POINTER BLOCK.</p>	B Y T E	BIT POSITIONS								7	6	5	4	3	2	1	0	F	MESSAGE COUNT								10	POINTER 1 (LSB)								11	POINTER 1 (MSB)								o	o								o	o								o	o								N-3	POINTER n (LSB)								N-2	POINTER n (MSB)								N-1	PCS (LSB)								N	PCS (MSB)							
B Y T E	BIT POSITIONS																																																																																																												
	7	6	5	4	3	2	1	0																																																																																																					
F	MESSAGE COUNT																																																																																																												
10	POINTER 1 (LSB)																																																																																																												
11	POINTER 1 (MSB)																																																																																																												
o	o																																																																																																												
o	o																																																																																																												
o	o																																																																																																												
N-3	POINTER n (LSB)																																																																																																												
N-2	POINTER n (MSB)																																																																																																												
N-1	PCS (LSB)																																																																																																												
N	PCS (MSB)																																																																																																												

Figure 6-3. Subscriber Transmission Unit (cont.)

BYTE	FIELD	DESCRIPTION
F-N (cont.)	MESSAGE POINTER BLOCK (cont.)	<p>POINTER n (LSB) is the LSB of the location of the start of NETWORK MESSAGE n relative to the start of the MESSAGE POINTER BLOCK.</p> <p>POINTER n (MSB) is the LSB of the check sequence calculated over the MESSAGE COUNT field and each of the MESSAGE POINTER fields. The algorithm used to calculate the check sequence is defined in appendix B.</p> <p>PCS (LSB) is the LSB of the check sequence calculated over the MESSAGE COUNT field and each of the MESSAGE POINTER fields. The algorithm used to calculate the check sequence is defined in appendix B.</p> <p>PCS (MSB) is the MSB of the check sequence calculated over the MESSAGE COUNT field and each of the MESSAGE POINTER fields. The algorithm used to calculate the check sequence is defined in appendix B.</p>
M1 - (M2-1)	NETWORK MESSAGE 1	Contains network message number 1.
Mn - Mz	NETWORK MESSAGE n	Contains network message number n.

Figure 6-3. Subscriber Transmission Unit (cont.)

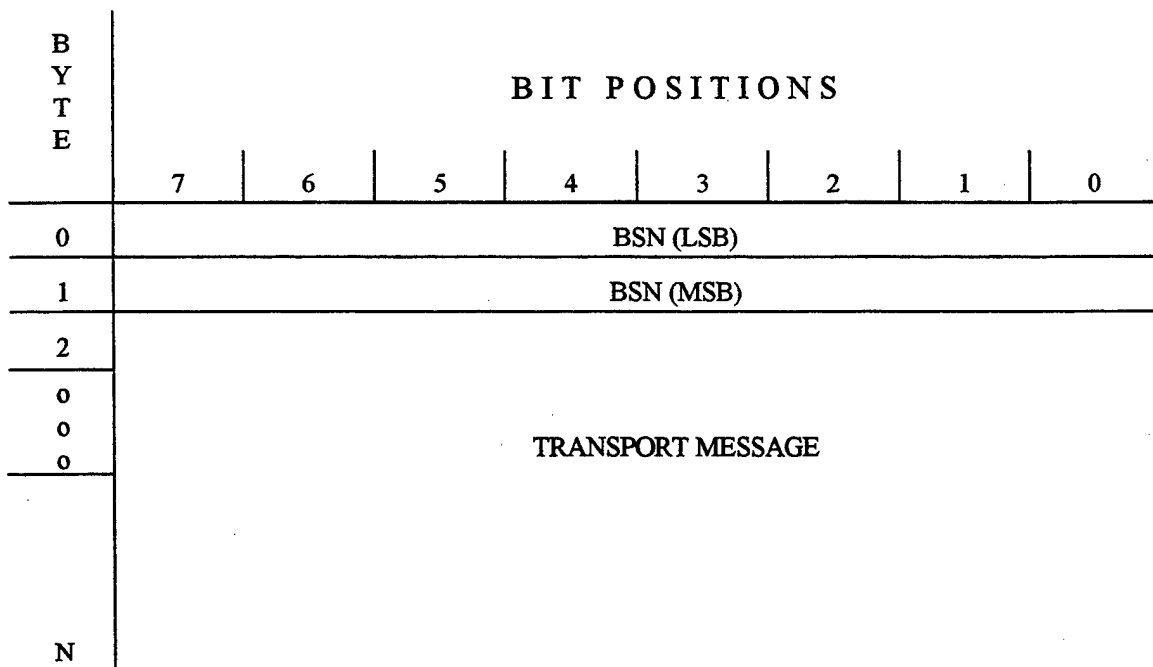

BYTE	FIELD	DESCRIPTION
0,1	BSN	Indicates the Broadcast Sequence Number (BSN) assigned to the TRANSPORT MESSAGE. Legal values are 0001-9999.
2-N	TRANSPORT MESSAGE	Contains the Transport Layer message as specified in the TADIXS IDS, Volume I. (Should be renamed to OTCIXS/TADIXS Transport Layer IDS).

Figure 6-4. Network Message

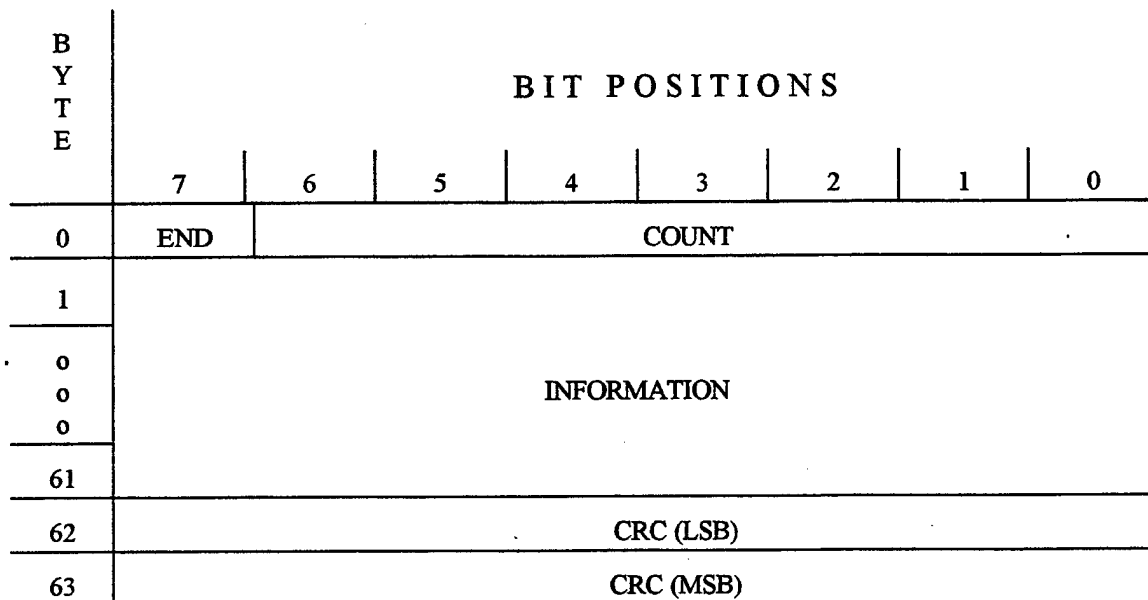

BYTE	FIELD	DESCRIPTION
0 (bits 0-6)	COUNT	Indicates the number of bytes in the INFORMATION field of the packet. With the exception of the final packet of a multipacket sequence, the value of this field shall be 97 (decimal) bytes. In the final packet of a multipacket sequence, legal values for this field are 1-97 (decimal) bytes.
0	END	Indicates if this packet is the final packet of a multipacket sequence. Value is 1 if this is the final packet; value is 0 if this is not the final packet.
1-61	INFORMATION	Consists of a part or all of a network message. The length of this field is indicated by the contents of the COUNT field. The INFORMATION field in all packets except the last of a multipacket sequence shall be 97 (decimal) bytes in length. The length of the INFORMATION field in final packet of a multipacket sequence is 1-97 (decimal) bytes.
62	CRC (LSB)	Contains the LSB of the CRC. Calculated over the COUNT, END, and INFORMATION fields. The CRC is calculated using the polynomial algorithm contained in appendix B.
63	CRC (MSB)	Contains the MSB of the CRC. Calculated over the COUNT, END, and INFORMATION fields. The CRC is calculated using the polynomial algorithm contained in appendix B.

Figure 6-5. Data Link Layer Packet Format

THIS PAGE INTENTIONALLY LEFT BLANK

APPENDIX A

LIST OF ACRONYMS and ABBREVIATIONS

Acronym	Definition
ADCCP	Advanced Data Communications Control Procedure
ASCII	American Standard Code for Information Interchange
BCS	Block Check Sequence
bps	bits per second
BPSK	Bi-phase Phase Shift Keyed
BSN	Broadcast Sequence Number
CCITT	International Telegraph and Telephone Consultative Committee
CCS	Combat Control System
CI	Control Indicator
CID	Component Identification
CMSA	Cruise Missile Support Activity
COMASWFOR	Commander, Antisubmarine Warfare Forces
COMSUBGRU	Commander, Submarine Group
COMSUBLANT	Commander, Submarine Forces Atlantic
COMSUBPAC	Commander, Submarine Forces Pacific
CONUS	Continental United States
CRA	Contention Resolution Algorithm
CRC	Cyclic Redundancy Check
CTS	Control Time Slot

Acronym	Definition
DAMA	Demand Assigned Multiple Access
DART	Dynamically Adaptive Receiver/Transmitter
DoD	Department of Defense
EASTPAC	Eastern Pacific
EOC	End of Cycle
ERCT	External Receive Ciphred Text
ETCT	External Transmit Ciphred Text
FCDSSA	Fleet Combat Direction Systems Support Activity
FCFS	First-Come, First-Served
FDDS	Flag Data Display System
FIFO	First-in, First-out
FLTSA	Fleet Satellite
FOSIC	Fleet Ocean Surveillance Information Center
FOSIF	Fleet Ocean Surveillance Information Facility
GRD	Guard
GSID	Granted Subscriber Identification
ID	Identification
IDS	Interface Design Specification
IF	Intermediate Frequency
IO	Indian Ocean
ISO	International Standards Organization
K/VDT	Keyboard/Video Display Terminal

Acronym	Definition
LANT	Atlantic
LAQ	Link Access Queue
LEASAT	Leased Satellite
LSB	Least Significant Byte
MDDS	Mission Data Distribution System
MED	Mediterranean
MIAR	Message Indicate Alarm Reset
MSB	Most Significant Byte
NCB	Net Control Block
NCS	Network Control Station
NCTAMS	Naval Computer and Telecommunications Area Master Station
NCTS	Naval Computer Telecommunications Station
NDF	Network Description File
NSDL	Network Simulation Description Language
N/U	Not Used
OSIS	Ocean Surveillance Information System
OTCIXS	Officer in Tactical Command Information Exchange Subsystem
OTH-T	Over-the-Horizon Targeting
OTH/DCT	Over-the-Horizon Detection, Classification and Targeting
PAC	Pacific
PCS	Pointer Check Sequence
PIO	Parallel Input/Output

<u>Acronym</u>	<u>Definition</u>
PREC	Precedence
RADCON	Radio Controller
RATS	Random Access Time Slot
RD0	Red Receive Data
RD1	Crypto Receive Data
RED-AI	Red Alarm Indicate
REMCON	Remote Controller
RESV	Reservation
rf	Radio Frequency
RP-STBYR	Remote Standby Red
RR	Reservation Request
RRTU	Reservation Request Transmission Unit
RS	Request Slot
RX-DPT	Receive Digital Plain Text
SAT	Satellite
SATCOM	Satellite Communications
SATS	Single Access Time Slot
SB STATUS	Scheduled Broadcast Status
SID	Subscriber Identification
SIGACQ	Signal Acquired
SIU	Sensor Interface Unit
SPAWARSYSCOM	Space and Naval Warfare Systems Command

<u>Acronym</u>	<u>Definition</u>
SSIXS	Submarine Satellite Information Exchange Subsystem
STM	Slot Time Mark
STT	Shore Targeting Terminal
STTS	Subscriber Transmission Time Slot
STU	Subscriber Transmission Unit
SYNC-CMD-TX	Synchronize Command Transmit
TADIXS A	Tactical Data Information Exchange Subsystem A
TBD	To Be Determined
TD0	Crypto Transmit Data
TD1	Red Transmit Data
TDDS	Tactical Data Display System
TDMA	Time Division Multiple Access
TDP	Tactical Data Processor
TDPCON	Tactical Data Processor Controller
TGF	TADIXS Gateway Facility
TGP	TADIXS Gateway Processor
TTY	Teletype
TU	Transmission Unit
TWCS	Tomahawk Weapons Control System
TX-DPT	Transmit Digital Plain Text
UHF	Ultrahigh Frequency
USCINCLANT	United States Commander-in-Chief, Atlantic

Acronym	Definition
USCINCPAC	United States Commander-in-Chief, Pacific
WESTPAC	Western Pacific
WPC	Washington Planning Center
XMIT CT	Transmit Count

APPENDIX B

CYCLIC REDUNDANCY CHECK SEQUENCE GENERATION

A. GENERAL. This appendix defines the Cyclic Redundancy Check (CRC) algorithm used by the data units of the OTCIXS II network. The generator polynomial used in the CRC calculation is the polynomial defined by the International Telegraph and Telephone Consultative Committee (CCITT) Recommendation V.41 and used in ANSI Standard X3.66 for Advanced Data Communication Control Procedures (ADCCP). This generator polynomial is: $G(X) = X^{16} + X^{12} + X^5 + 1$.

B. CRC GENERATION ALGORITHM. The software algorithm which realizes this process is shown in Figure B-1. For convenience of implementation, and to permit high speed generation of the CRC, the algorithm has been designed to process one 8-bit byte at a time. Figure B-2 contains a listing of the algorithm as programmed for an 8080 microprocessor. Table B-1 provides samples from the CRC generation algorithm.

Table B-1. Sample Inputs/Outputs For CRC Generator

INPUT (Hexadecimal)			RESULT (Hexadecimal)	
HI BYTE	LO BYTE	ACCUMULATOR	HI BYTE	LO BYTE
FF	FF	01	F1	D1
FF	FF	00	E1	F0
FF	FF	80	70	78
00	00	01	10	21
00	00	80	91	88
55	55	01	4F	71
55	55	80	CE	D8
55	55	55	55	00
AA	AA	AA	AA	00

STEP	OPERATION
1	A = Incoming Byte
2	I = CRCHI .XOR. A
3	A = I .RS. 4
4	A = I .XOR. A
5	I = A
6	A = A .LS. 4
7	A = A .XOR. CRCLO
8	J = A
9	A = I
10	A = A .RS. 3
11	A = A .XOR. J
12	CRCHI = A
13	A = I
14	A = A .LS. 5
15	A = A .XOR. I
16	CRCLO = A

Where:

- A is an 8-bit accumulator register
- I and J are 8-bit scratch pad registers
- CRCHI is the high order 8 bits of the CRC
- CRCLO is the low order 8 bits of the CRC
- .XOR. is an 8-bit Exclusive OR operation
- .RS. is a right-shift
- .LS. is a left-shift

Note: Right- and left-shifts "pull zeros," e.g., ABCDEFGH right-shifted 3 would produce 000ABCDE.

Initial value of CRCHI and CRCLO is zero before applying this algorithm to data bytes in the data frame.

Figure B-1. CRC Generator Algorithm

CRC - ROUTINE TO CALCULATE THE CRC FOR 8080 MICROPROCESSOR.

ON ENTRY, H = MSB OF CRC, L = LSB OF CRC, A = NEW BYTE;
RESULT IS H = MSB OF NEW CRC, L = LSB OF NEW CRC.

```
CRC: XRA H      ;EXCLUSIVE-OR CRC MSB AND ACCUM
      MOV D,A   ;STORE IN SCRATCHPAD
      RRC      ;SHIFT ACCUM RIGHT 4
      RRC
      RRC

      RRC
      ANI 0FH   ;ACCUMULATOR NOW HAS 0000IJKL
      XRA D     ;EXCLUSIVE-OR SCRATCHPAD AND ACCUM
      MOV D,A   ;RESULT IS IJKLMNOP, SAVE IN SCRATCHPAD

      RLC      ;SHIFT ACCUM LEFT 4
      RLC
      RLC
      RLC
      ANI 0F0H  ;ACCUM NOW HAS MNOP0000
      XRA L     ;XOR ACCUM AND LSB OF CRC
      MOV H,A   ;PUT RESULT IN MSB OF CRC TEMPORARILY
      MOV A,D   ;BRING BACK IJKLMNOP TO ACCUM
      RRC      ;SHIFT ACCUM RIGHT 3
      RRC
      RRC
      ANI 1FH   ;ACCUM NOW HAS 000IJKLM
      XRA H     ;XOR MSB OF CRC AND ACCUM
      MOV H,A   ;STORE RESULT AS NEW CRC MSB
      MOV A,D   ;BRING BACK IJKLMNOP TO ACCUM
      RLC      ;SHIFT ACCUM LEFT 5
      RLC
      RLC
      RLC
      RLC
      ANI 0E0H  ;ACCUM NOW HAS NOP00000
      XRA D     ;XOR SCRATCHPAD AND ACCUM
      MOV L,A   ;RESULT IS NEW CRC LSB
      RET      ;EXIT SUBROUTINE
```

Figure B-2. 8080 Listing of CRC Generator

THIS PAGE INTENTIONALLY LEFT BLANK

APPENDIX C Section C1

OTCIXS II SIMULATION PERFORMANCE RESULTS

A. PURPOSE.

The Officer in Tactical Command Information Exchange Subsystem (OTCIXS) is an existing subsystem of the Navy Ultrahigh Frequency (UHF) Satellite Communications (UHF SATCOM) System that provides beyond line-of-sight automatic exchange of tactical messages between ships, submarines and shore facilities. Subscribers may exchange computer-to-computer formatted data (datalink) messages or teletype messages via the OTCIXS network. The OTCIXS network operates on a demand assign basis so that when a subscriber needs to transmit data, access to the network can be gained quickly. The OTCIXS network also provides for priority preemption so that subscribers with higher priority data can gain control of the network by interrupting the normal transmission of lower priority data. The current OTCIXS network functions well in the current mode; that is, without the use of multiplexing equipment. However, there is a limited ability to support all of the network subsystems that exist today with the limited hardware and satellite resources available. The increasing requirements for satellite communications links and the limited number of available satellite channels and transmit/receive equipment have led to the need for sharing available resources. This can be accomplished only by limiting the number of networks supported by a subscriber or by using multiplexing equipment.

Early analysis indicates that the current OTCIXS network will not operate efficiently using the TD-1271 B/U Demand Assigned Multiple Access (DAMA)

multiplexing equipment. This has necessitated the development of a proposed a new protocol for OTCIXS that will provide efficient performance for both non-DAMA and DAMA operations. This report describes the methods of analyzing the new proposed protocol for the OTCIXS network (hereafter referred to as OTCIXS II) for both non-DAMA and DAMA operations. The primary focus of this analysis is on message throughput times, queue wait times, message throughput rate, and network transmission utilization. These values are obtained for various scenario/exercises consisting of different combinations of total messages per hour generated by the simulation, different number of high and low priority network access request slots, and with and without automatic rescheduling of subscriber access to the network for data transmission.

The different scenario/exercise parameters, as applicable, are used with both the OTCIXS I and OTCIXS II simulations to provide comparative results between the old and newly proposed protocols. The simulation program and network model are only approximations of real world operations but are providing both OTCIXS I and OTCIXS II simulation test results, at least a comparison of the newly proposed protocol to the old can be reasonably performed. The simulation of the newly proposed protocol will exhibit both the errors and deficiencies exhibited by the old; by providing results for both protocols, it is assumed that reasonable conclusions can be drawn from the simulation results.

B. BACKGROUND.

The increasing requirements for satellite communications links using limited number of available satellite channels have led to the development of DAMA which

permits several UHF SATCOM subsystems to share a single 25 kHz satellite channel. Either the Fleet Satellite (FLTSAT) or Leased Satellite (LEASAT) can be used for OTCIXS operations. A subscriber designated as a Net Control Station (NCS) coordinates the use of the OTCIXS network. Surface ships and shore sites are capable of assuming the NCS function. The NCS receives, queues, and acknowledges receipt of subscriber access requests. The NCS assigns transmission times to all high priority (flash) requests, scheduled low priority (immediate) broadcast requests, and finally non-scheduled immediate requests. Once a subscriber has been authorized by the NCS to transmit its message data, the subscriber initiates message transmission; in the proposed OTCIXS II protocol, the subscriber will not be preempted by other message transmissions regardless of precedence of the message involved.

DAMA divides channel transmission into 1.38667 second intervals called frames. Each frame is divided into burst transmission subintervals called slots. There are several groupings of slots within a frame; these are called frame formats. Frame formats consist of combinations of slots supporting user transfer-rate to DAMA burst-rate transmissions. User rates vary from 75 bits per second (bps) to 16,000 bps; DAMA bursts rates vary from 9,600 to 32,000 symbols per second. Some slots are dedicated for DAMA operations and are not available for general use. The rest of the transmission time in a frame is allocated to user slots. Each network is assigned a slot to use based on those available within the active frame format at the time the network is attached to DAMA.

It was assumed that user networks can operate in a DAMA environment with little or no change to the program software. However, analysis of the OTCIXS network

indicates that this is not a correct assumption. A model of the OTCIXS network for non-DAMA and DAMA operations was developed to analyze OTCIXS performance. Results from this analysis show degraded operations in the DAMA environment. It is therefore anticipated that a new OTCIXS protocol would need to be defined to operate in the DAMA environment without suffering the degradation of the current network protocol. This analysis is an attempt to determine the performance characteristics of the newly proposed OTCIXS II protocol. Only the non-DAMA operation of the current OTCIXS network operations was analyzed since the DAMA operation has degraded performance, which the newly proposed protocol is intended to correct.

C. NETWORK SIMULATION SUMMARY.

The analysis of network performance used several different items of data to provide the various different simulations. These items included subscriber message queue wait times, message throughput times, message throughput rates, and network utilization. These were measured for both the OTCIXS I and the proposed OTCIXS II protocol. The effects of missed or lost messages were not key concerns of this effort. The loss of traffic is caused by many factors including the quality of transmit/receive equipment, atmospheric conditions, and satellite performance characteristics; these are difficult to model and only a crude approximation can be simulated. The loss of messages is assumed to affect both protocols the same; thus, the main emphasis is on determining how the differences in the two protocols effect overall performance. Rather than concentrating on those functions of network performance related to transmission quality, this analysis concentrates on the network access and control characteristics.

Each protocol operates in cycles. These cycles provide the ability for subscribers to request and use the network for transmitting data to other subscribers. The different protocols manage these cycles differently. This analysis measures the functions affected by the different cycle management schemes and attempts to compare OTCIXS I performance to that of the proposed OTCIXS II.

Performance of both protocols is measured in a non-DAMA environment. Both protocols operate in non-DAMA environments, and this provides compatible results that can be used to compare one protocol to the other. The proposed OTCIXS II protocol is also measured in a DAMA environment; these results are useful in determining and degradation of OTCIXS II performance in a DAMA environment.

1. Queue Wait Times.

Queue wait time is the measure of time between receipt of a message in a subscriber and the transmission of the message over the network, i.e., the amount of time messages are queued in the subscriber before transmission. This time includes delays that result from access transmission requests, request collisions, cycle times, and, in the case of the proposed OTIXS II protocol, access scheduling. The shorter the queue wait time for a message the timelier the data in the message is. Thus, shorter queue wait times indicate better performance. This allows measuring the effects of the different cycle management techniques on network access.

2. Message Throughput Times.

Message throughput time is the measure of time between receipt in the source

device to receipt of the message in the destinations device; message throughput is divided into subscriber to subscriber (link controller to link controller) and tactical data processor (TDP) or teletype (TTY) to TDP or TTY throughput times. These times are useful in measuring the effects transmitting data more than one time. The OTCIXS I protocol transmits TDP data separately from TTY data; the OTCIXS II proposed protocol does not. Message throughput time provides a method of measuring this difference in operation.

3. Message Throughput Rate.

Message throughput rates are the measure of number of messages over the network. For purposes of this analysis, message throughput rate is the number of messages transferred from one subscriber to another subscriber or subscribers. This measure is used to attempt to determine the upper bound of message throughput for the network. This is needed to determine if the network protocol is anticipated to satisfy the specification objective of 200 messages per hour.

4. Network Utilization.

Network Utilization is the measure of network time used for data transmission. This measure is a percentage of the total available time and the amount of time used to transmit network control data, access requests, and subscriber data. Network utilization measures the amount of network time lost due to idle time, guard times, and network inefficiencies.

APPENDIX C - Section C2

DESCRIPTION

A. OTCIXS I MODEL.

The OTCIXS I model is based on the currently operational protocol for the OTCIXS network. This protocol includes variable network access request time slots, data, transmission units which include either datalink or teletype messages, but not both at the same time, and transmission of the net control block (NCB) before transmission of each copy of the transmission unit (TU). The network is designed to operate in a non-DAMA UHF environment. Subscribers gain access to the network by demanding use of the network, and can preempt use of the network from lower priority message transmissions.

Subscribers in the OTCIXS I network gain access to the network to transmit data by transmitting access requests during periods of time reserved for request demands. There is one high priority request time slot (PRTS) reserved exclusively for use by subscribers who have flash message traffic to transmit. There are up to 19 general access request time slots (GATS) for use by subscribers with flash or immediate message traffic. The PRTS and GATS intervals are discontinued once a subscriber demands use of the network. Thus, any one cycle has between one and twenty request time slots, but does not necessarily have all twenty every time.

The NCB precedes the request slots in every cycle. After the request time slots interval is the time dedicated to the subscribers for transmission of data. A cycle consists of the NCB, the PRTS and GATS, and one copy of a data TU if there is one. An idle

cycle is a cycle during which not data is transmitted. A single access time slot (SATS) cycle is a cycle during which one copy of a data TU is transmitted. Each copy of a multiple copy TU is preceded by a NCB transmission.

In summary, the OTCIXS I network protocol preceded subscriber transmission with the transmission of a NCB. Up to twenty request time slots were provide to subscribers to demand access to the network, but the request time slot interval is discontinued when the first demand transmission takes place; and each copy of a TU is preceded by the transmission of the NCB. Also, the model developed to analyze OTCIXS I performance does not include scheduled broadcast traffic.

The simulation program was designed to implement these functions with assumptions on how the network operated. These assumptions include the effects of signal-to-noise on data transmissions, cryptographic equipment probability for sequence failure, and message throughput distributions. The simulation program provides a means of analyzing network performance based on the functional operation of the network and algorithms that model performance characteristics, assumed or known to occur in an UHF environment.

B. OTCIXS II MODEL

The proposed OTCIXS II network protocol incorporates several changes to the current protocol. These include providing all request time slots in every cycle; sending all copies of a data TU when network access is granted by the NCS; and once the network is granted to a subscriber to transmit data, no other subscriber can preempt the network from the transmitting subscriber. The specific details of how the OTCIXS II network

operates can be found in the body of this thesis. The model provides the ability to perform different variations in network operations.

The OTCIXS II protocol allows for a variable number of flash and immediate message random access time slots (RATS); the NCB identifies how many of each type of access time slot is available during the next cycle. Subscriber demands, received as requests transmitted during the RATS, for access to the network to transmit data are scheduled by the NCS and queued on a first-in, first-out (FIFO) order by request priority.

All allocated request time slots are provided during each cycle, and the request time slot interval is not truncated when the first demand is transmitted, as is the case in the OTCIXS I protocol. The OTCIX II protocol currently allows high priority requests to use any of the available request slots, and are not limited to using only the dedicated high priority request slot(s). The OTCIXS II protocol provides a mechanism to schedule subscribers without requiring them to demand access during the request time slot interval.

The two methods currently under consideration, that have been modeled, are "piggy-backing", i.e., a request for access in the TU, and providing a list of subscribers that are automatically polled, i.e., automatically scheduled for network access without the necessity of demanding access.

The OTCIXS II protocol provides for transmission of all buffered messages in the subscriber station when access to the network is granted. The TU will contain either flash and immediate datalink and teletype messages. TUs are limited to 10103 bytes of message data plus the overhead data bytes needed for the TU. This is intended to reduce the number of access requests a subscriber should need to make to transmit buffered messages.

The simulation program has been modified to perform these functions based on the assumptions and message generation algorithms used in the OTCIXS I simulation program. As much as possible of the original simulation model has been maintained with the new functional definitions and performance characteristics layered onto them. This will provide some comparative analysis of the OTCIXS II performance with respect to the OTCIXS I analysis.

1. OTCIXS Simulation Components.

The OTCIXS simulation consists of three components. The first is the program; the set of instructions that perform the functional processing of the network. The second is the network model; the definitions of the subscriber and message generation characteristics. The third is the setup file; the parameters that allow quick and simple modifications of the data or processing of the simulation program.

The simulation program consists of the algorithms for performing the functionally processing of the OTCIXS network. The algorithms for generating messages, simulating induced noise errors, and simulating cryptographic equipment synchronization failures have been left as originally designed. The OTCIXS I non-DAMA processing has also been left intact. The changes that have been made incorporated the new proposed protocol functionality/timing processing described in body of this thesis. The proposed new protocol processing is designed to perform the same cyclic functional operations whether non-DAMA or DAMA. The cycle interval times are adjusted to DAMA time slot values when the DAMA environment is being simulated. The message generation processing uses the three equations for message arrival patterns: Poisson, Negative

Binomial, and Periodic. However, the simulation program originally designed specified message traffic per hour as a parameter defined in the model definition. The program has been modified so that the model defines the percentage of total message per hour a specific subscriber generates, and the setup file defines the actual messages per hour value for the network as a whole. This change allows for more flexibility in simulating various different traffic rates without having to redefine the entire model. The message multiplier parameter in the setup file is still available, but its use affects subscriber percentage, not the actual traffic rate.

a. *Model Description.*

The simulation program consists of the algorithms needed to simulate the network operation. The data describing the subscribers, the types and characteristics of messages, and the frequency with which each subscriber generates the different types of messages is provided in a network description file (NDF). The NDF is produced by describing the subscriber and network characteristics in a network simulation description language (NSDL). The source is then converted into a binary interpretation used by the simulation program. Appendix A is a listing of the source NSDL used for this analysis. The following summarizes the characteristic used to analyze the proposed OTCIXS II protocol:

1. The network model consists of 40 subscribers generating a non-uniform distribution of messages. This is accomplished by defining six of the subscribers as type 1 (best), or type 2 (good) quality transmit stations, generating approximately 78 to 80 percent of the message traffic. The remainder of the subscriber stations are type 2 or type 3 (poorest) quality transmit stations equally generating 20 percent of the message traffic.

2. The model is designed to produce a mix of 80 percent immediate and 20 percent flash messages, with 90 percent of the messages being datalink and 10 percent being teletype messages.

3. Message generation distribution is poisson for all subscribers.

4. The traffic load, messages per hour, is specified in the program setup file and is varied to simulate different traffic loads.

5. The model is defined to generate 25 percent discrete-addressed and 75 percent collective-addressed messages. There are six collective addressees defined with approximately equal probability for selection.

6. Each subscriber has only one of the collective address values in its guard list. The six collective address values are equally distributed among the 40 subscriber stations.

b. Setup File Description.

The program setup file allows the operator to fine tune the exercise for the current simulation. The setup file definition is functionally the same as the originally constructed for the OTCIXS I simulation. However, modifications have been made, these include; adding parameters to change the traffic load (messages per hour), the number of RATS, the number of RATS to be used for high priority requests, whether automatic piggy-backed requests processing is enabled, and selection of frequent users to be included in the automatic poll list. Appendix B describes the setup file, including changes, used for this analysis.

Some parameters have been deleted since they were not used: such things

as the header length of teletype messages and block byte count size parameter definition have been eliminated. The teletype message header size parameter has been deleted; the assumption is that the header and end of message bytes are included in the generated message size and do not need to be added in separately. The block byte count size parameter is calculated based on the maximum block byte count size parameter specified in the setup file.

Several parameters in the setup file were set to the same values for all scenarios tested. The network is defined to transmit 8-bit characters at 2400 PBS. The options used to differentiate the various scenarios and exercises are;

1. The number of messages generated per hour
2. The number of request slots available per cycle
3. Whether the new protocol (OTCIXS II) or the old protocol is being simulated
4. Whether DAMA mode processing is enabled for an OTCIXS II simulation
5. Whether piggy-backed rescheduling is enabled
6. Whether frequent user polling is enabled and the subscribers to be polled.

2. Automatic Rescheduling.

The OTCIXS uses a demand request protocol to gain access of the network to transmit data. When several subscribers are actively transmitting data on the network,

there is a likelihood that more than one subscriber will transmit a request at the same time.

This contention for the limited number of request slots results in poor use of the network, depending on such factors as how many requests have already been scheduled and the precedence of the requests that were lost. Automatic rescheduling of subscribers has been considered as a method of reducing the number of requests that would have to be made, thus reducing the contention for a request slots available. The two methods under consideration at this time are piggy-back and frequent user polling.

a. Piggy-backed Requests.

A piggy-backed request would be implemented by putting data into the TU header requesting use of the network as soon as available, based on the priority of the data to be transmitted. In essence, the request transmission is piggy-backed onto the data transmission. Subscribers can piggy-back a request based on various criteria, receipt of more data after transmission has begun or prediction that more data will soon arrive. The simulation program has been updated to emulate the first option. The simulation program determines if additional messages have been received in the Link Controller or are about to be transmitted from the TDP to the Link Controller. If either of these conditions is true, a piggy-backed request is indicated and the subscriber is automatically rescheduled for network access. No predictive algorithms have been modeled.

b. Frequent Users Polling List.

A polling list rescheduling mechanism has been built-in to the simulation program. When a subscriber transmits data on the network, the subscriber's identification

number is checked to see if it is in the frequent users list. If it is, the subscriber is automatically rescheduled for an immediate message transmission. Subscribers are put into the frequent users list by parameters entered in the setup file. If no subscribers are identified as frequent users, then frequent user polling is in effect disabled. The model has been modified so that a frequent user subscriber always transmits when selected, in order to keep the frequent user in the scheduling list. This has resulted in emulation a no-data informing NCB that the network is not needed, but transmission of data indicating nothing is being sent or detection of a quiescent channel.

THIS PAGE INTENTIONALLY LEFT BLANK

APPENDIX C - Section C3

PERFORMANCE RESULTS

A. TEST CRITERIA.

In section 2 the model definition and setup files are described; these files provide the simulation program user the capability to simulate or test a large number of different combinations of network operational characteristics. This section discusses the tests that were run and their results. To achieve the goals of this analysis only a limited set of data was required. Only the necessary combinations of network characteristics were set up and tested to obtain this data.

The data for this analysis was obtained by executing the simulation program using the model and setup file data described in section II. However, the simulation program gives only a rough approximation of the real world operation. The simulated testing of the OTCIXS II was based on the real world OTCIXS I historical program data, and cannot for certain determine whether the specified requirements will be satisfied. The test results provide data for basing comparisons on how different parameters affect operations.

This is also the base for comparing OTCIXS I and OTCIXS II performance. The deficiencies in the data for OTCIXS I testing are the same for OTCIXS II test data. The same routines and algorithms were used for both protocols with the only differences being in the network cycle control routines. The validity of the conclusions drawn in the analysis are based on the validity of the program and model. Therefore, it is assumed, without proof, that the program and model are close approximations and provide results that are reasonable indications of performance.

Given the above assumption, the OTCIXS II proposed protocol tests use a minimum and maximum cycle time scenario. For the purposes of testing, the minimum cycle time is the net cycle using one high priority and two low priority RATS. The maximum cycle time is the net cycle using two high priority and six low priority RATS. These scenarios are tested with an increasing traffic load; the tests are performed again using the two different rescheduling techniques.

The minimum RATS scenario produces the shortest OTCIXS II network cycle times, but also produces the greatest contention. The maximum RATS scenario produces the longest cycle times, but also reduces overall contention. The test data showed the following contention/collision performance. The minimum RATS scenario went from 1.7% of the total number of requests colliding at 100 messages per hour to 8.6% of the total number of requests colliding at 400 messages per hour. The maximum RATS scenario went from 2.6% at 100 messages per hour to 6.3% at 400 messages per hour. The minimum scenario had 7 collisions at 100 messages per hour and 83 collisions at 400 messages per hour. The maximum scenario had 11 collisions at 100 messages per hour and 51 collisions at 400 messages per hour. The minimum scenario had more total cycles with an approximate average of 490 cycles per hour. The minimum scenario provided fewer overall opportunities for subscribers to request access to the network (based on 980 cycles per hour times 3 RATS per cycle for a minimum and 490 times 8 for the maximum) and also had a higher percentage and total number of collisions. The conclusion is the minimum scenario provides shorter cycles but reduces the opportunity to request access to the network. However, this reduced access does not necessarily mean poorer use of the network. At lower traffic loads many of the cycles are idle, i.e., there is no data to

transmit. The following test cases are designed to show if the decreased number of RATS degrade or improve network performance. The OTCIXS II DAMA mode is also included with the non-DAMA mode results for both the minimum and maximum scenarios. The time interval difference skews the network cycle times higher, but the operational trends should still be comparable.

Table C3-1 contains the simulation results for the OTCIXS I network. This data is used in comparing the results from the OTCIXS II simulation. The following subsections analyze how these different extremes affect message wait times, subscriber to subscriber times, and network utilization.

B. SCENARIO 1: MINIMUM CYCLE.

Table C3-2 and C3-3 summarizes the test result for the minimum cycle scenario. Figures C3-1 and C3-2 are graphical interpretations of the result values for the subscriber queue wait and the subscriber to subscriber service times against those of OTCIXS I. The data compared to table C3-1 shows very similar performance. The data shows that OTCIXS I queue wait times for high priority messages are shorter than those for OTCIXS II, but OTCIXS II low priority queue wait times are shorter than OTCIXS I. The DAMA operation uses the network time nearly the same as the non-DAMA operation, however the times are approximately 30% higher. The effective message throughput rates per hour are also very close the same for OTCIXS I and OTCIXS II non-DAMA, and OTCIXS II DAMA.

Table C3-1. OTCIXS I Simulation Data Results (non-DAMA Mode in seconds)

Messages per hour		Wait Queue Times		End to End Delivery		Controller to Controller Service		Utility	# Request	Sched Bcst	
ACT	EFF	Lo	Hi	Lo	Hi	Lo	Hi	%	Slots	Lo	Hi
100	89.0	20.8	8.7	62.0	48.5	32.4	19.3	27.8	19 1	0	0
200	129.8	36.8	11.0	65.6	41.3	49.2	22.6	35.9	19 1	0	0
300	205.4	107.1	11.8	128.2	54.3	124.6	28.0	51.7	19 1	0	0
400	244.8	233.2	24.8	336.3	89.8	253.8	41.6	56.7	19 1	0	0

Table C3-2. OTCIXS II Minimal Cycle Time (non-DAMA Mode in seconds)

Messages per hour		Wait Queue Times		End to End Delivery		Controller to Controller Service		Utility	# Request	Sched Bcst	
ACT	EFF	Lo	Hi	Lo	Hi	Lo	Hi	%	Slots	Lo	Hi
100	88.6	7.5	6.6	42.1	50.5	17.7	17.6	20.4	2 1	3	1
200	158.8	13.4	10.3	51.5	46.7	24.1	19.2	35.7	2 1	3	2
300	182.2	19.3	12.7	68.8	54.5	31.1	23.9	41.4	2 1	3	3
400	227.2	28.1	16.9	79.9	61.4	41.1	29.5	49.3	2 1	5	3

Table C3-3. OTCIXS II Minimal Cycle Time (DAMA Mode in seconds)

Messages per hour		Wait Queue Times		End to End Delivery		Controller to Controller Service		Utility	# Request	Sched Bcst	
ACT	EFF	Lo	Hi	Lo	Hi	Lo	Hi	%	Slots	Lo	Hi
100	88.6	29.1	20.1	67.5	70.8	43.5	36.1	20.0	2 1	2	2
200	160.8	47.3	31.5	90.3	67.7	66.1	45.9	34.7	2 1	4	2
300	218.0	82.9	38.8	120.9	87.6	106.2	59.4	46.8	2 1	8	4
400	221.8	98.7	43.4	156.0	101.5	121.0	65.0	47.4	2 1	8	3

C. SCENARIO 2: MAXIMUM CYCLE.

Tables C3-4 and C3-5 summarize the test results for the maximum cycle scenario. Figures C3-3 and C3-4 are graphical interpretations of the results values for the subscriber queue wait, and subscriber to subscriber service times. The data compared to table C3-1 shows that high priority subscriber to subscriber times for both OTCIXS I and OTCIXS II non-DAMA are similar, with OTCIXS II DAMA being higher. Low priority OTCIXS II non-DAMA times were lower than either OTCIXS I or OTCIXS II DAMA. Subscriber

queue wait time results were similar to subscriber to

Table C3-4. OTCIXS II Maximum Cycle Time (non-DAMA Mode in seconds)

Messages per hour		Wait Queue Times		End to End Delivery		Controller to Controller Service		Utility	# Request	Sched Bcst	
ACT	EFF	Lo	Hi	Lo	Hi	Lo	Hi	%	Slots	Lo	Hi
100	89.9	15.6	12.0	52.1	50.1	28.5	24.7	20.4	6 2	2	2
200	149.0	19.9	15.7	64.7	53.9	33.6	29.2	32.7	6 2	3	2
300	235.0	46.2	25.0	92.8	68.8	63.7	40.9	52.4	6 2	7	3
400	203.0	46.5	24.9	96.5	73.8	63.1	40.7	44.1	6 2	7	3

Table C3-5. OTCIXS II Maximum Cycle Time (DAMA Mode in seconds)

Messages per hour		Wait Queue Times		End to End Delivery		Controller to Controller Service		Utility	# Request	Sched Bcst	
ACT	EFF	Lo	Hi	Lo	Hi	Lo	Hi	%	Slots	Lo	Hi
100	81.2	45.9	32.5	90.3	88.0	69.1	56.6	17.6	6 2	3	2
200	140.6	82.4	40.6	137.2	92.2	109.2	66.3	29.2	6 2	8	2
300	211.6	176.2	59.0	251.0	133.7	210.9	94.2	43.8	6 2	13	4
400	310.3	509.9	106.1	969.1	577.8	559.4	159.7	63.4	6 2	24	5

Subscriber service times except that OTCIXS I high priority times were lower. The DAMA operation uses the network time slightly more than the non-DAMA operation, however OTCIXS I utilization percentages were higher. The effective message throughput rate per hour for non-DAMA was slightly higher than OTCIXS I while OTCIXS II DAMA was significantly higher than OTCIXS I.

D. SCENARIO 3: MINIMAL CYCLE WITH PIGGY-BACK SCHEDULING.

Tables C3-6 and C3-7 summarize the test results for the minimal cycle scenario with piggy-back scheduling. Figures C3-5 and C3-6 are graphical interpretations of the result values for subscriber to subscriber service and the subscriber queue wait times against those for the minimum cycle with no rescheduling. The subscriber to subscriber

service time data from tables C3-6 and C3-7 compared to tables C3-2 and C3-3 show that both non-rescheduled and piggy-backed OTCIXS II subscriber to subscriber service and subscriber queue wait times for either high or low priority messages are quite similar.

E. SCENARIO 4: MINIMUM CYCLE WITH FREQUENT USER POLLING.

Tables C3-8 and C3-9 summarize the test results for the minimum cycle scenario with frequent user polling. Figures C3-7 and C3-8 are graphical interpretations of the result values for subscriber to subscriber and subscriber queue wait times against those for the minimum cycle with no rescheduling. The subscriber to subscriber service time data from tables C3-8 and C3-9 compared to tables C3-2 and C3-3 show that both non-DAMA frequent user polled and non-rescheduled high priority messages result in similar performance during scenarios with less than 400 messages per hour generated. This is also true for DAMA high priority messages. With low priority messages, non-rescheduled non-DAMA performed slightly better than low priority frequent user non-DAMA, while the poorest performance came from both frequent user and non-rescheduled DAMA. The effective message throughput per hour for frequent user polling was slightly higher for DAMA, but for the most part less for non-DAMA.

Table C3-6. OTCIXS II Minimum Cycle Time/Piggy-Backed Rescheduling
(non-DAMA Mode in seconds)

Messages per hour		Wait Queue Times		End to End Delivery		Controller to Controller Service		Utility	# Request	Sched Bcat	
ACT	EFF	Lo	Hi	Lo	Hi	Lo	Hi	%	Slots	Lo	Hi
100	92/6	7.6	6.2	40.6	49.6	17.7	17.3	21.1	2 1	3	2
200	143.4	11.5	9.0	51.1	42.2	25.6	19.2	32.1	2 1	4	2
300	176.6	18.9	13.7	59.8	54.3	30.9	18.7	39.8	2 1	3	2
400	231.2	30.0	18.7	83.7	65.5	43.1	32.2	50.8	2 1	5	3

Table C3-7. OTCIXS II Minimum Cycle Time/Piggy-Backed Rescheduling
(DAMA Mode in seconds)

Messages per hour		Wait Queue Times		End to End Delivery		Controller to Controller Service		Utility	# Request	Sched Bcat	
ACT	EFF	Lo	Hi	Lo	Hi	Lo	Hi	%	Slots	Lo	Hi
100	83.4	23.5	18.8	63.4	61.9	38.3	18.0	18.0	2 1	2	3
200	151.2	35.7	24.2	83.6	63.9	53.3	33.1	33.1	2 1	3	2
300	180.2	61.8	31.0	118.2	74.6	81.6	40.1	40.1	2 1	7	3
400	217.6	107.4	33.5	172.3	93.2	128.8	46.2	46.2	2 1	11	4

Table C3-8. OTCIXS II Minimum Cycle Time Frequent User Polling
(non-DAMA Mode in seconds)

Messages per hour		Wait Queue Times		End to End Delivery		Controller to Controller Service		Utility	# Request	Sched Bcat	
ACT	EFF	Lo	Hi	Lo	Hi	Lo	Hi	%	Slots	Lo	Hi
100	92.6	13.3	6.0	47.7	60.3	23.3	17.0	20.3	2 1	7	2
200	141.6	19.7	8.5	60.2	46.9	30.8	19.5	30.9	2 1	8	2
300	193.2	29.9	11.9	84.4	58.3	43.3	24.4	42.7	2 1	9	2
400	198.0	32.9	14.0	126.9	67.5	45.5	25.8	41.6	2 1	10	7

**Table C3-9. OTCIXS II Minimum Cycle Time Frequent User Polling
(DAMA Mode in seconds)**

Messages per hour		Wait Queue Times		End to End Delivery		Controller to Controller Service		Utility	# Request		Sched B Bcst	
ACT	EFF	Lo	Hi	Lo	Hi	Lo	Hi	%	Slots		Lo	Hi
100	92.6	45.8	20.2	88.4	67.3	61.7	37.0	20.4	2	1	8	2
200	168.2	75.0	26.9	125.1	70.8	92.7	44.6	36.1	2	1	9	2
300	217.8	109.1	35.7	178.6	86.8	139.5	57.5	46.6	2	1	12	3
400	245.4	170.9	41.8	240.2	97.1	198.8	65.9	51.4	2	1	18	3

F. SCENARIO 5: MAXIMUM CYCLE WITH PIGY-BACK SCHEDULING.

The tables C3-10 and C3-11 summarize the test results for the maximum cycle scenario with piggy-back rescheduling. Figures C3-9 and C3-10 are graphical interpretations of the result values for subscriber to subscriber queue wait times against those for the maximum cycle with no rescheduling. The subscriber to subscriber service time data from tables C3-10 and C3-11 compared to table C3-4 and C3-5 show non-DAMA high priority messages tended to be lower overall, with piggy-back scheduling times shorter during traffic loads of 200 to 300 messages per hour, but increasing significantly for traffic loads of greater than 300 messages per hour. The same is true for non-DAMA low priority messages. All DAMA subscriber to subscriber service times tended to be higher overall. Subscriber queue wait times followed the same trend as subscriber to subscriber service times. Network utilization for piggy-back scheduling and non-rescheduled non-DAMA operations were fairly similar until the 300 message level when non-rescheduled percentages were higher. Network utilization for piggy-back scheduling and non-scheduled DAMA operations were fairly even. Effective message throughput per hour was similar between piggy-back scheduling and non-scheduling.

**Table C3-10. OTCIXS II Maximum Cycle Time/Piggy-Back Rescheduling
(non-DAMA Mode in seconds)**

Messages per hour		Wait Queue Times		End to End Delivery		Controller to Controller Service		Utility	# Request	Sched Bcst	
ACT	EFF	Lo	Hi	Lo	Hi	Lo	Hi	%	Slots	Lo	Hi
100	89.8	14.1	10.4	50.0	51.3	26.8	23.4	19.9	6 2	3	2
200	141.8	19.8	15.7	106.6	55.4	34.0	28.9	30.9	6 2	3	2
300	159.8	27.1	17.0	87.8	66.9	42.2	30.9	34.8	6 2	5	3
400	243.6	61.7	27.6	109.7	70.5	79.6	46.0	51.1	6 2	11	3

**Table C3-11. OTCIXS II Maximum Cycle Time/Piggy-Back Rescheduling
(DAMA Mode in seconds)**

Messages per hour		Wait Queue Times		End to End Delivery		Controller to Controller Service		Utility	# Request	Sched B Bcst	
ACT	EFF	Lo	Hi	Lo	Hi	Lo	Hi	%	Slots	Lo	Hi
100	87.8	45.3	33.0	91.6	91.0	68.7	57.1	19.3	6 2	3	2
200	125.2	77.5	38.0	130.2	93.6	101.2	62.2	26.6	6 2	6	3
300	226.2	246.5	55.1	338.6	127.2	283.6	90.5	90.5	6 2	14	3
400	216.6	236.9	71.2	341.5	153.4	273.9	107.5	107.5	6 2	17	5

G. SCENARIO 6: MAXIMUM CYCLE WITH FREQUENT USER POLLING.

Tables C3-12 and C3-13 summarize the test results for the maximum cycle scenario with frequent user polling. Figures C3-11 and C3-12 are graphical interpretations of the result values for subscriber to subscriber service and subscriber queue wait times against those of the maximum cycle with no rescheduling. The subscriber to subscriber service time data from tables 3-12 and C3-13 compare to tables C3-4 and 3-5 show non-DAMA high priority message service times the shortest and fairly even. Non-rescheduled non-DAMA low priority service times were better than their frequent user polled counterparts. Similarly to scenario 5, all DAMA subscriber to subscriber service times tended to be higher overall. Subscriber queue wait times paralleled the same trend as subscriber to subscriber which tends to be much higher than its non-rescheduled counterpart. Non-

rescheduled network utilization percentages were slightly higher than frequent user polling, while effective message throughput per hour was fairly even.

Table C3-12 OTCIXS II Maximum Cycle Time Frequent User Polling
(non-DAMA Mode in seconds)

Messages per hour		Wait Queue Times		End to End Delivery		Controller to Controller Service		Utility	# Request	Sched Bcst	
ACT	EFF	Lo	Hi	Lo	Hi	Lo	Hi	%	Slots	Lo	Hi
100	88.6	25.9	13.3	64.8	57.2	38.9	26.7	20.0	6 2	8	2
200	134.8	35.4	13.1	115.6	57.8	50.6	27.2	28.8	6 2	8	2
300	206.4	61.3	29.2	133.2	62.3	79.9	36.9	43.8	6 2	12	4
400	208.2	84.5	25.6	148.3	79.4	105.2	42.1	44.8	6 2	13	4

Table C3-13 OTCIXS II Maximum Cycle Time Frequent User Polling
(DAMA Mode in seconds)

Messages per hour		Wait Queue Times		End to End Delivery		Controller to Controller Service		Utility	# Request	Sched Bcst	
ACT	EFF	Lo	Hi	Lo	Hi	Lo	Hi	%	Slots	Lo	Hi
100	83.2	83.6	31.4	140.0	85.4	108.5	55.0	17.2	6 2	8	2
200	145.4	141.7	41.9	196.3	96.7	169.8	67.8	30.5	6 2	12	3
300	205.8	221.0	55.9	334.7	118.7	261.3	89.4	43.5	6 2	16	5
400	268.4	300.4	74.5	672.5	390.1	347.4	121.1	55.3	6 2	19	5

H. SUMMARY AND CONCLUSIONS.

The OTCIXS I upper effective message throughput is about 300 messages per hour. The OTCIXS II non-DAMA upper effective message throughput was about 250 messages per hour. While OTCIXS II DAMA appears to have an upper effective message throughput of about 325 messages per hour, there seems to be some timing conditions involved. Under certain conditions OTCIXS II DAMA can reach more than 300 messages per hour, but at a cost. As the system generates more than 300 messages per hour, the subscriber queue wait time increases significantly.

The OTCIXS II protocol provides better performance for low priority messages.

The servicing of high priority message is comparable for both protocols. The data also shows OTCIXS II DAMA operations perform as well as non-DAMA operations considering message throughput and utilization, but with higher wait and throughput times. If the assumption is true that DAMA will exhibit fewer contention events resulting in mutual destruction, then DAMA should use the available request opportunities that are provided. Frequent user polling tends to show poorer performance indicated by longer queue wait times.

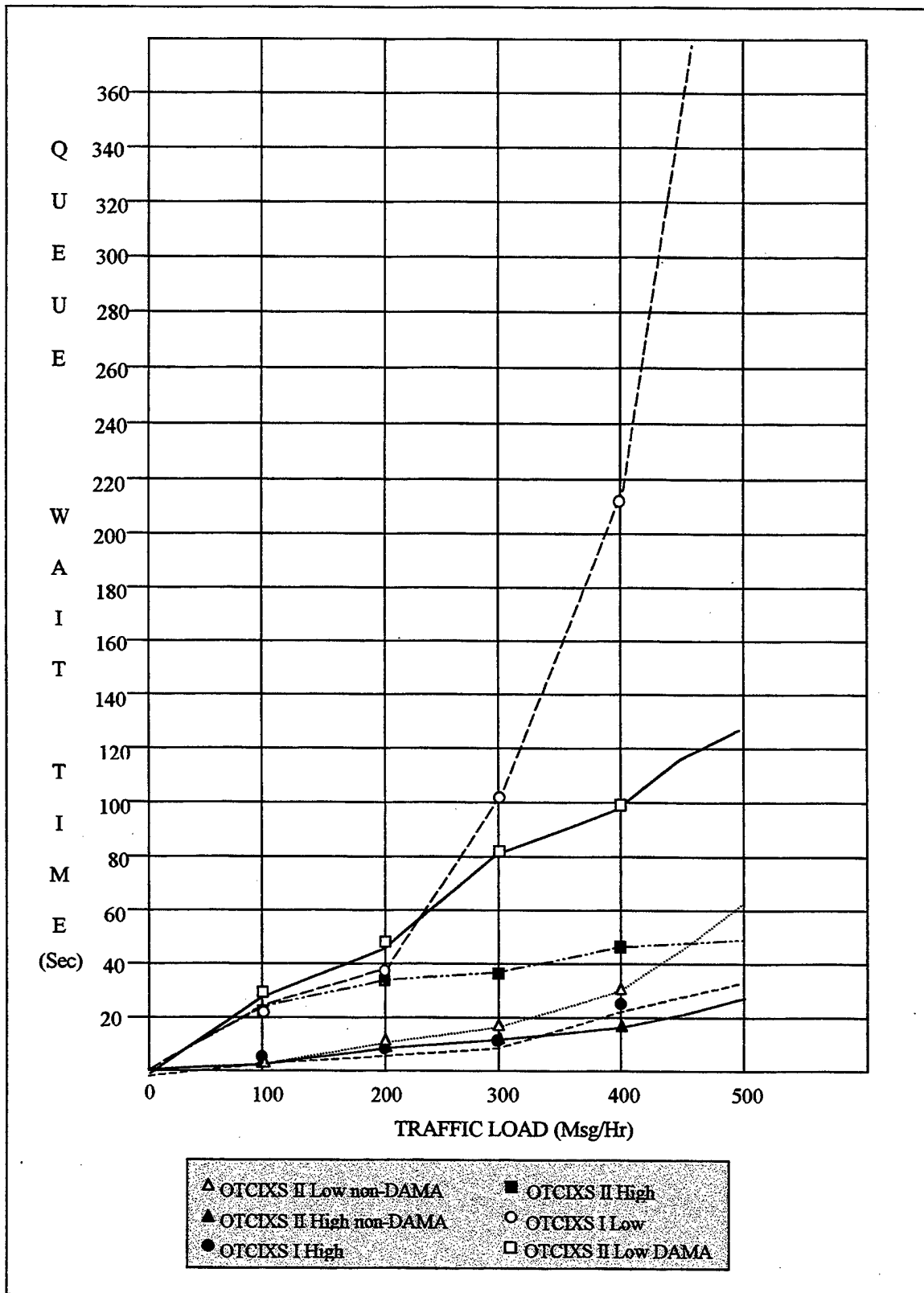

Figure C3-1. OTICXS I vs. OTICXS II Minimal Subscriber Queue Wait Time

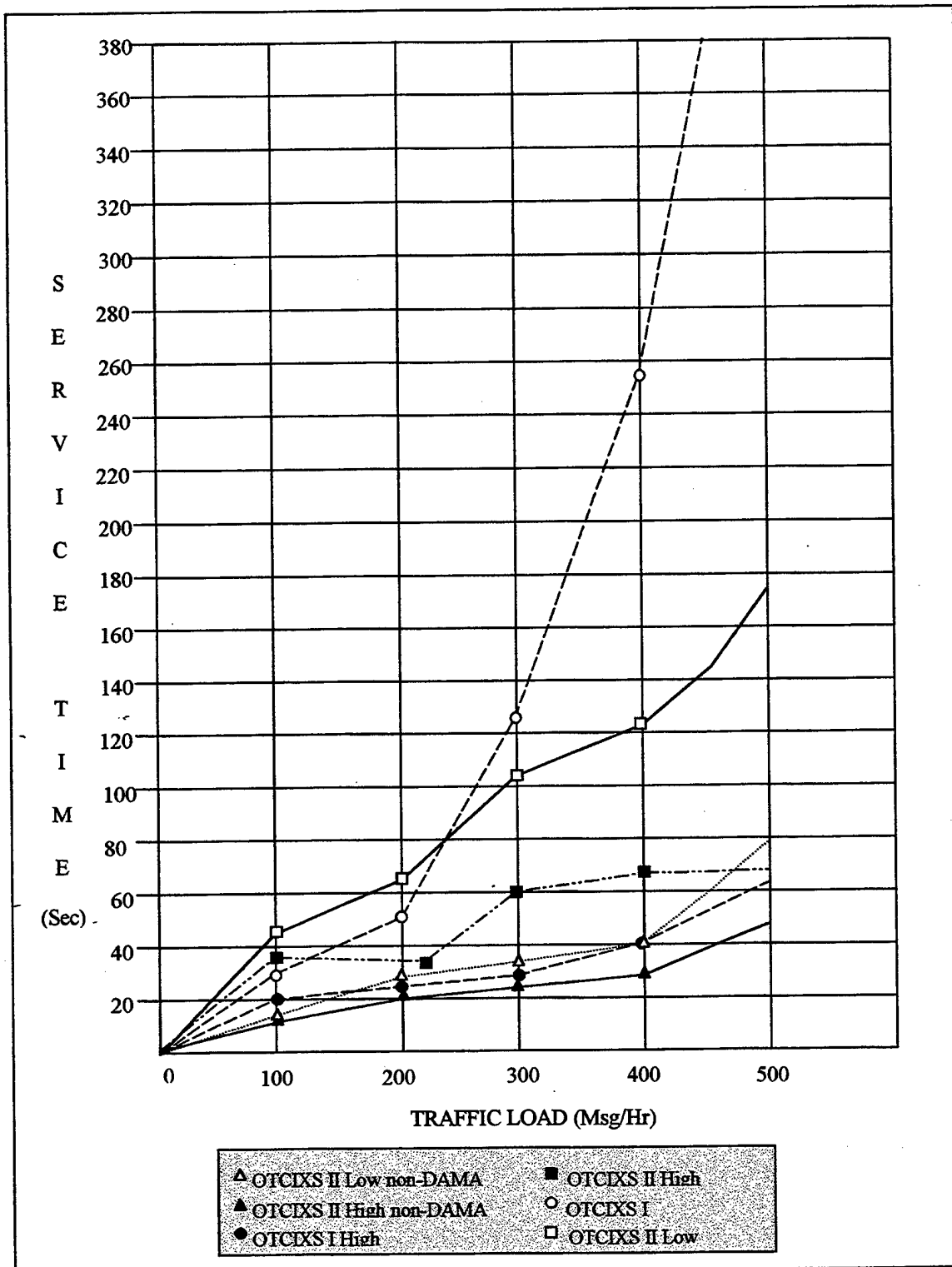

Figure C3-2. OTCIXS I vs. OTCIXS II Minimum Subscriber to Subscriber Service Time

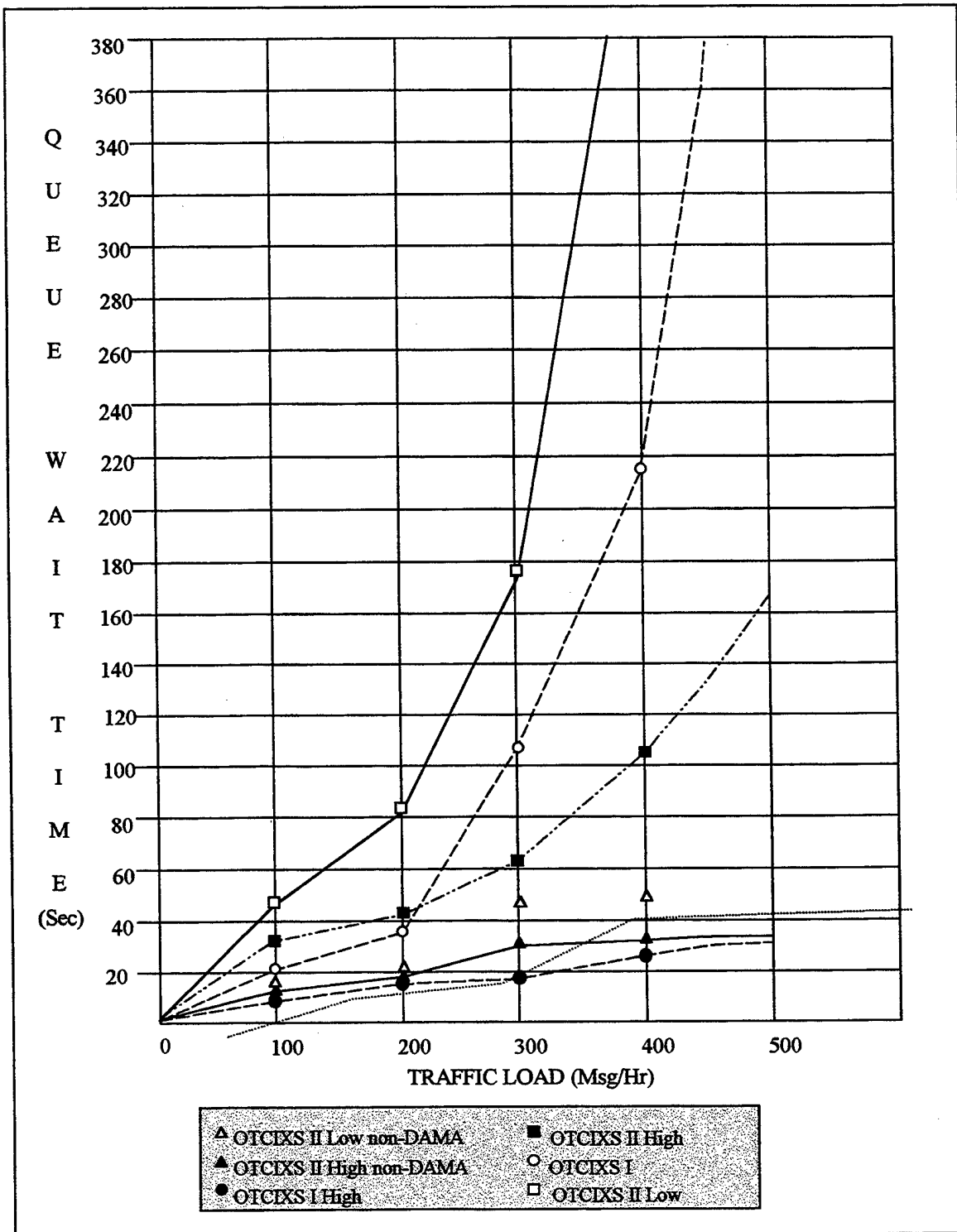

Figure C3-3. OTCIXS I vs. OTCIXS II Maximum Subscriber Queue Wait Time

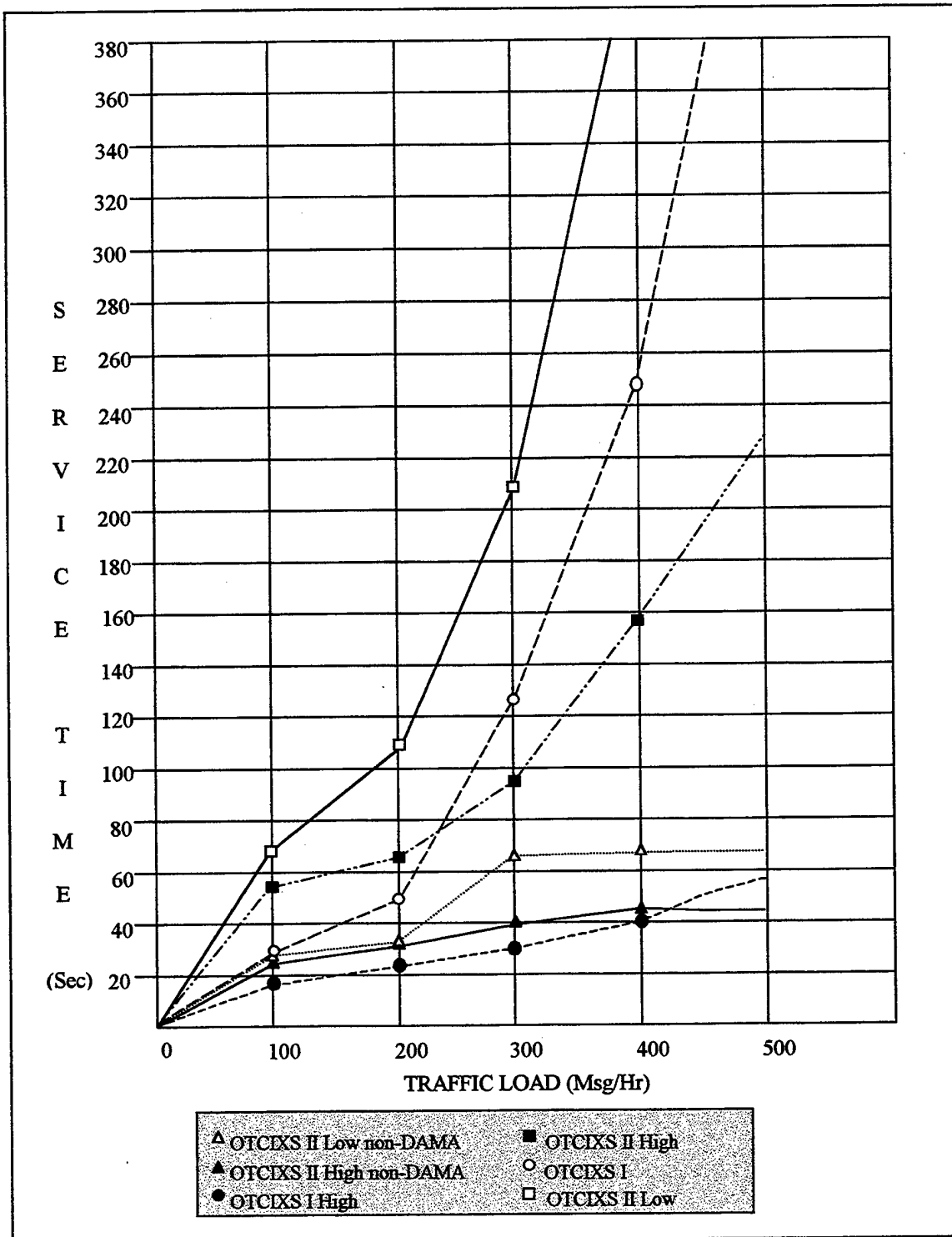

Figure C3-4. OTCIXS I vs. OTCIXS II Maximum Subscriber to Subscriber Service Time

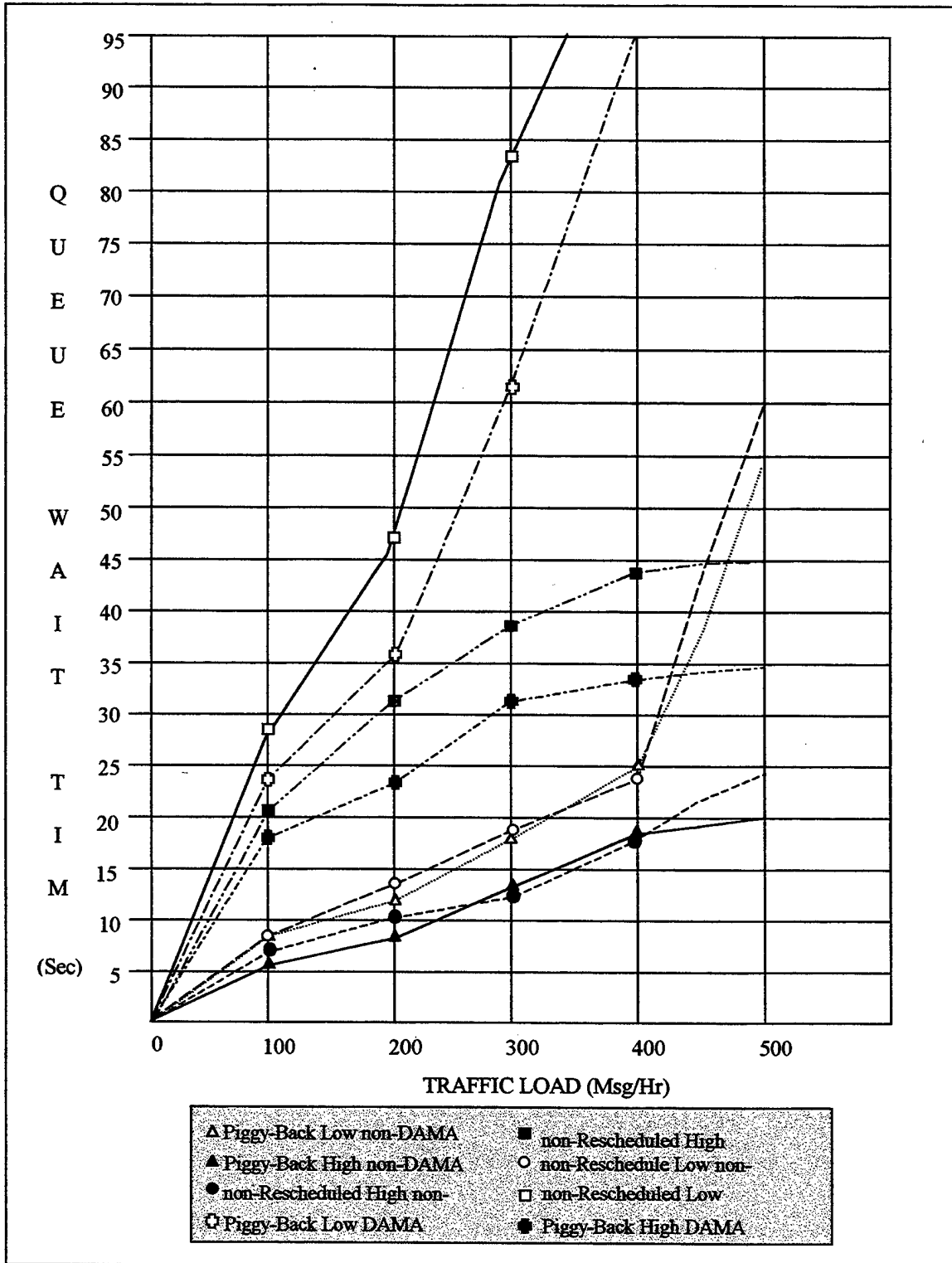

Figure C3-5. OTCIXS II Minimum: non-Rescheduled vs. Piggy-Back Queue Wait Time

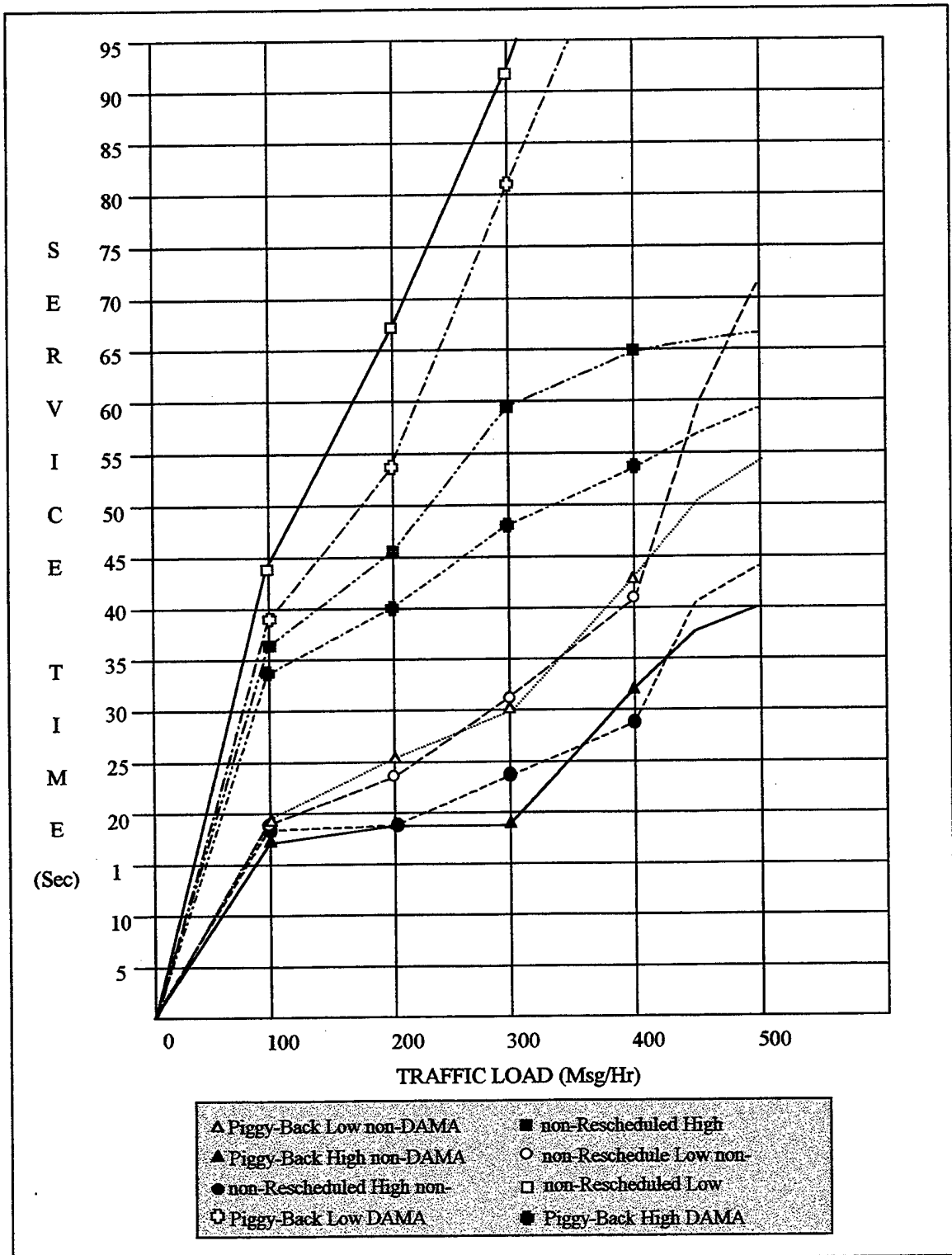

Figure C3-6. OTCIXS II Minimum: non-Rescheduled vs. Piggy-Back Service Time

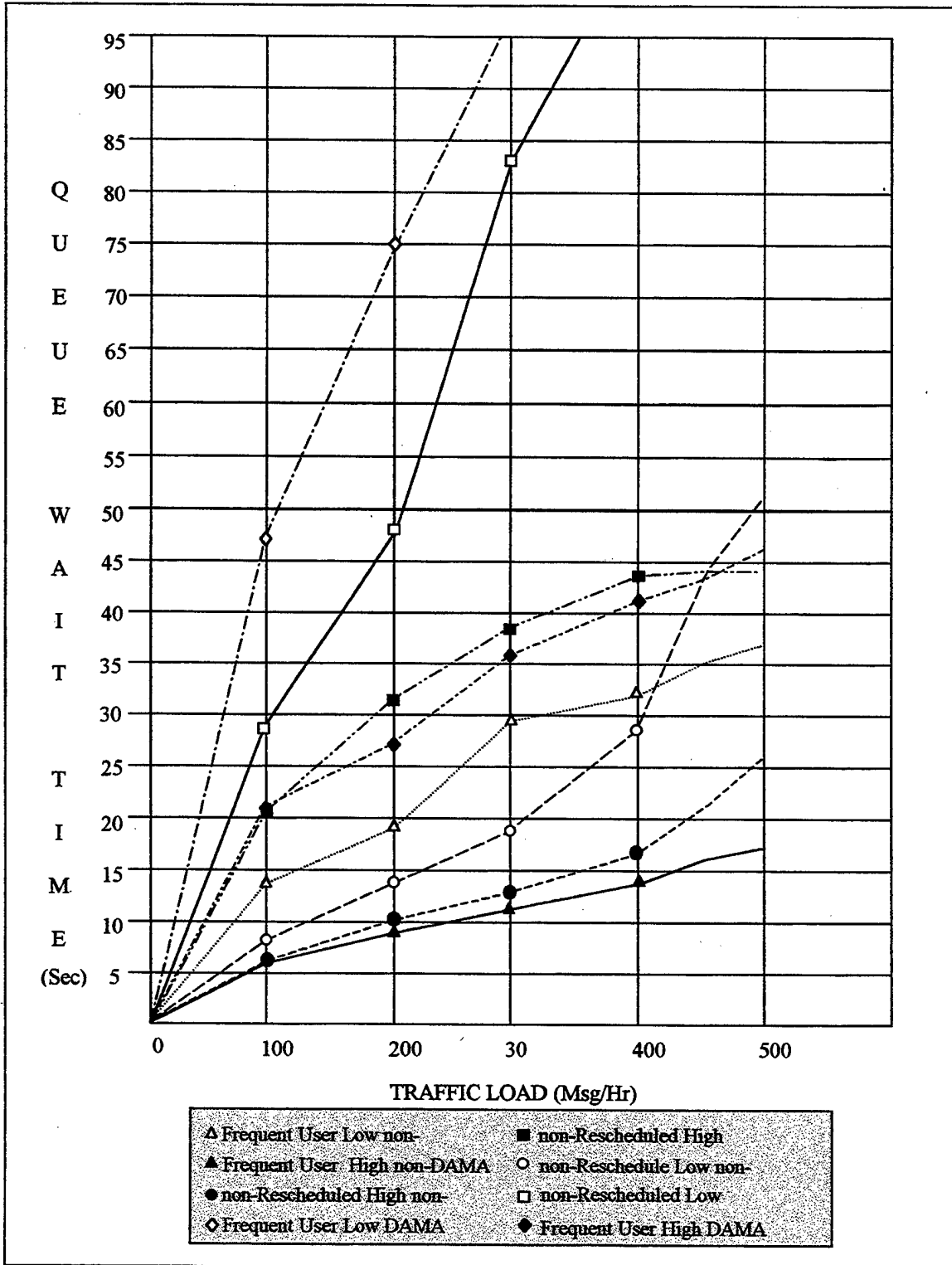

Figure C3-7. OTCIXS II Minimum: non-Rescheduled vs. Frequent User Queue Wait Time

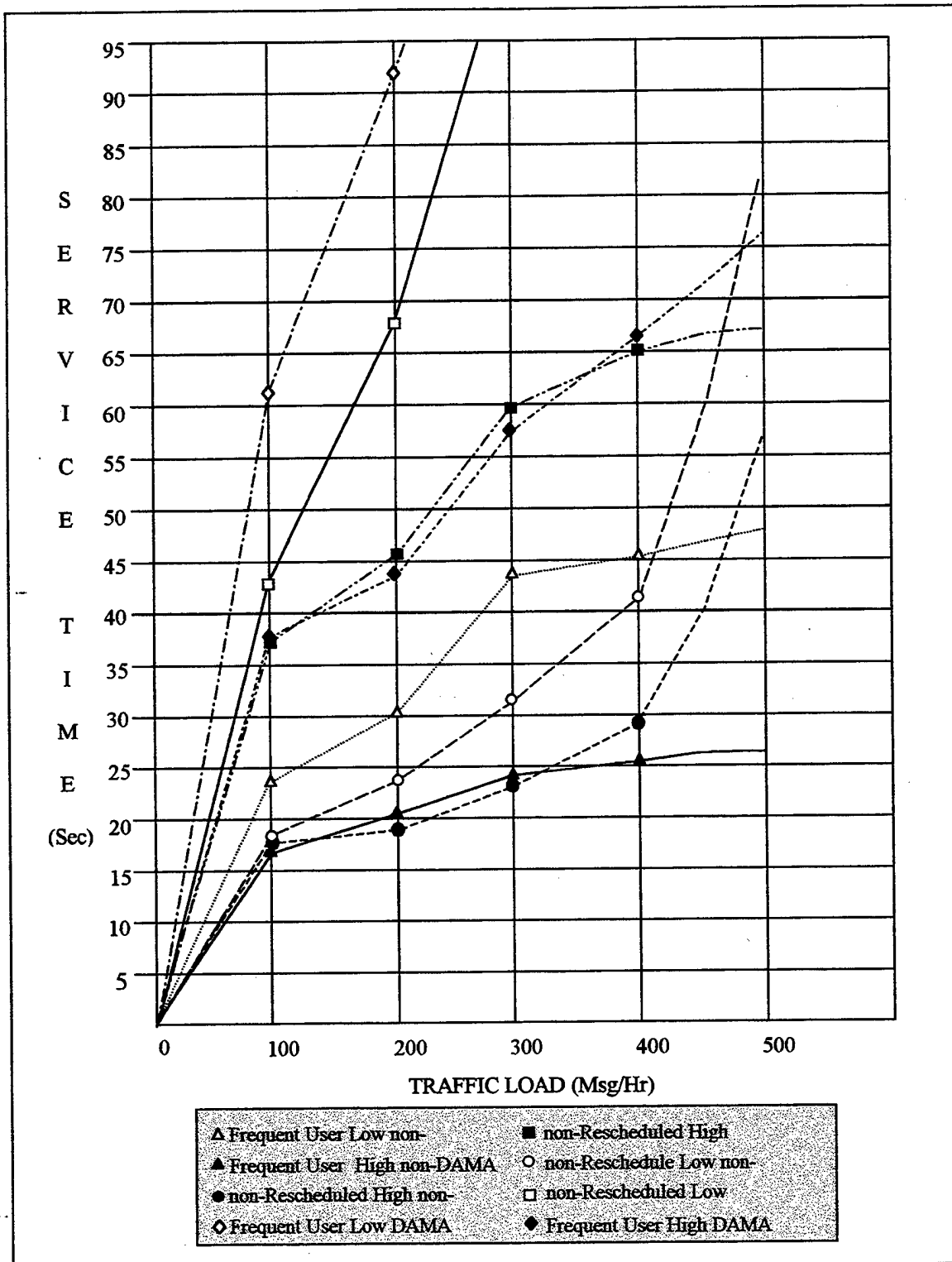

Figure C3-8. OTCIXS II Minimum: non-Rescheduled vs. Frequent User Service Time

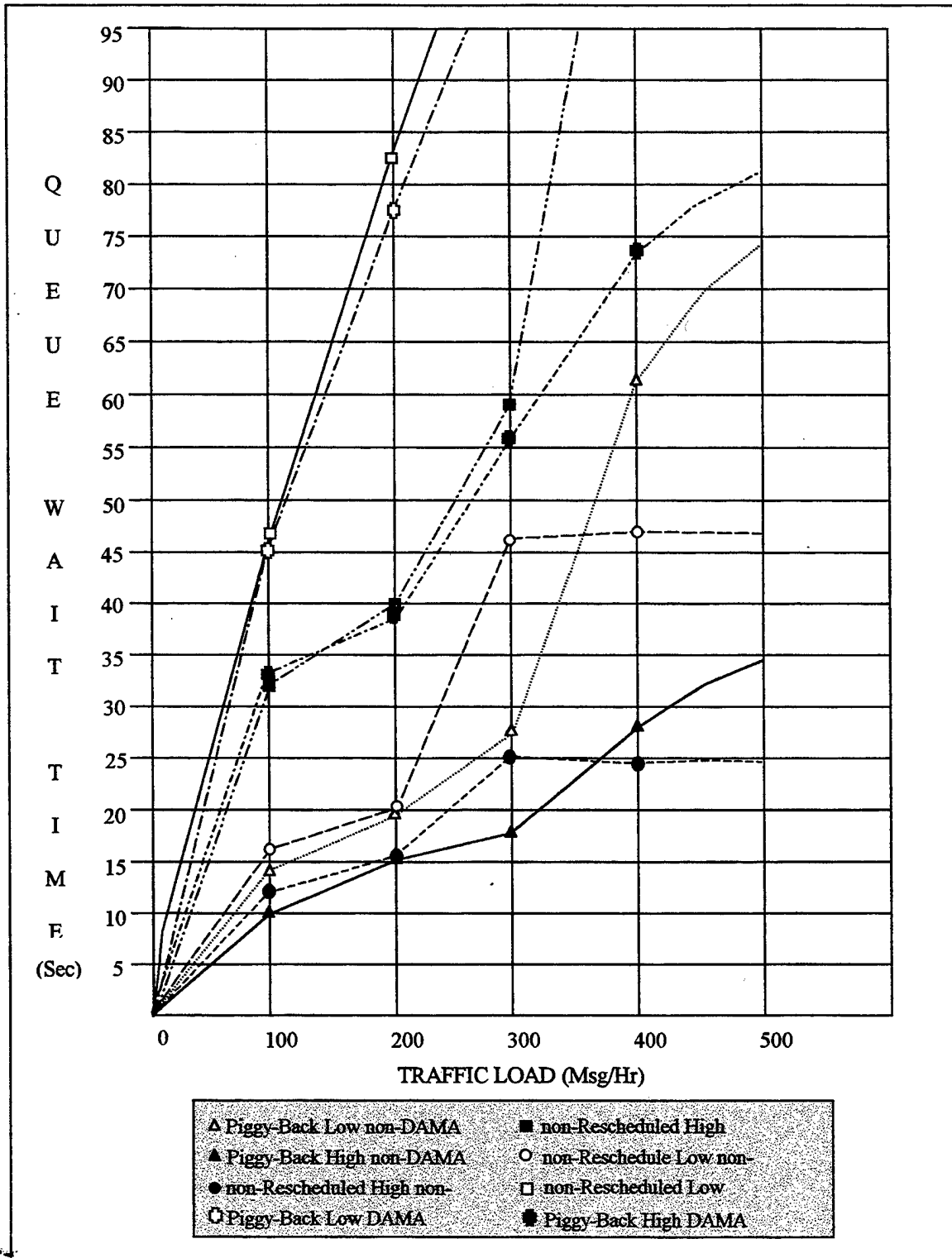

Figure C3-9. OTCIXS II Maximum: non-Rescheduled vs. Piggy-Back Queue Wait Time

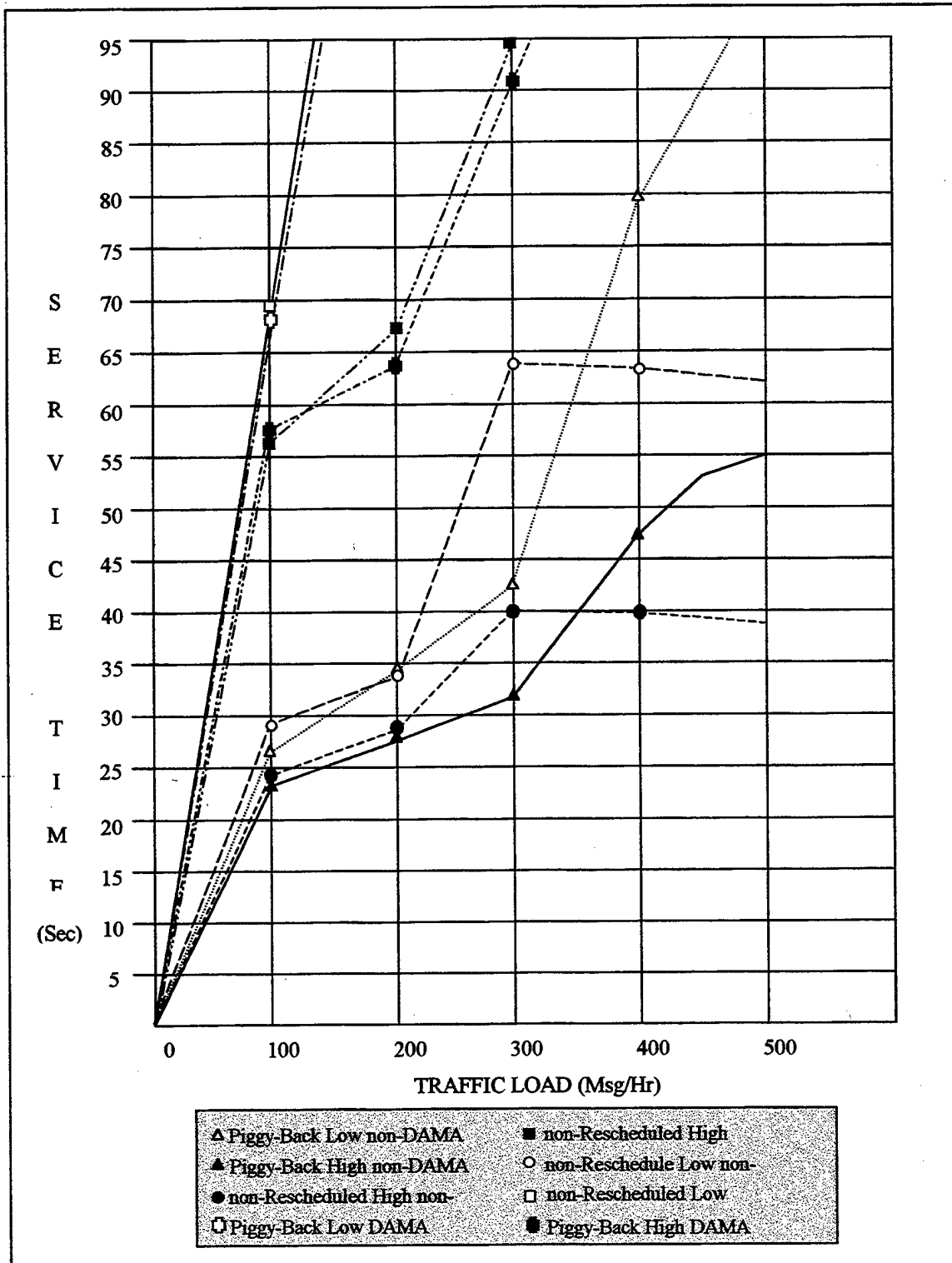

Figure C3-10. OTCIXS II Maximum: non-Rescheduled vs. Piggy-Back Service Time

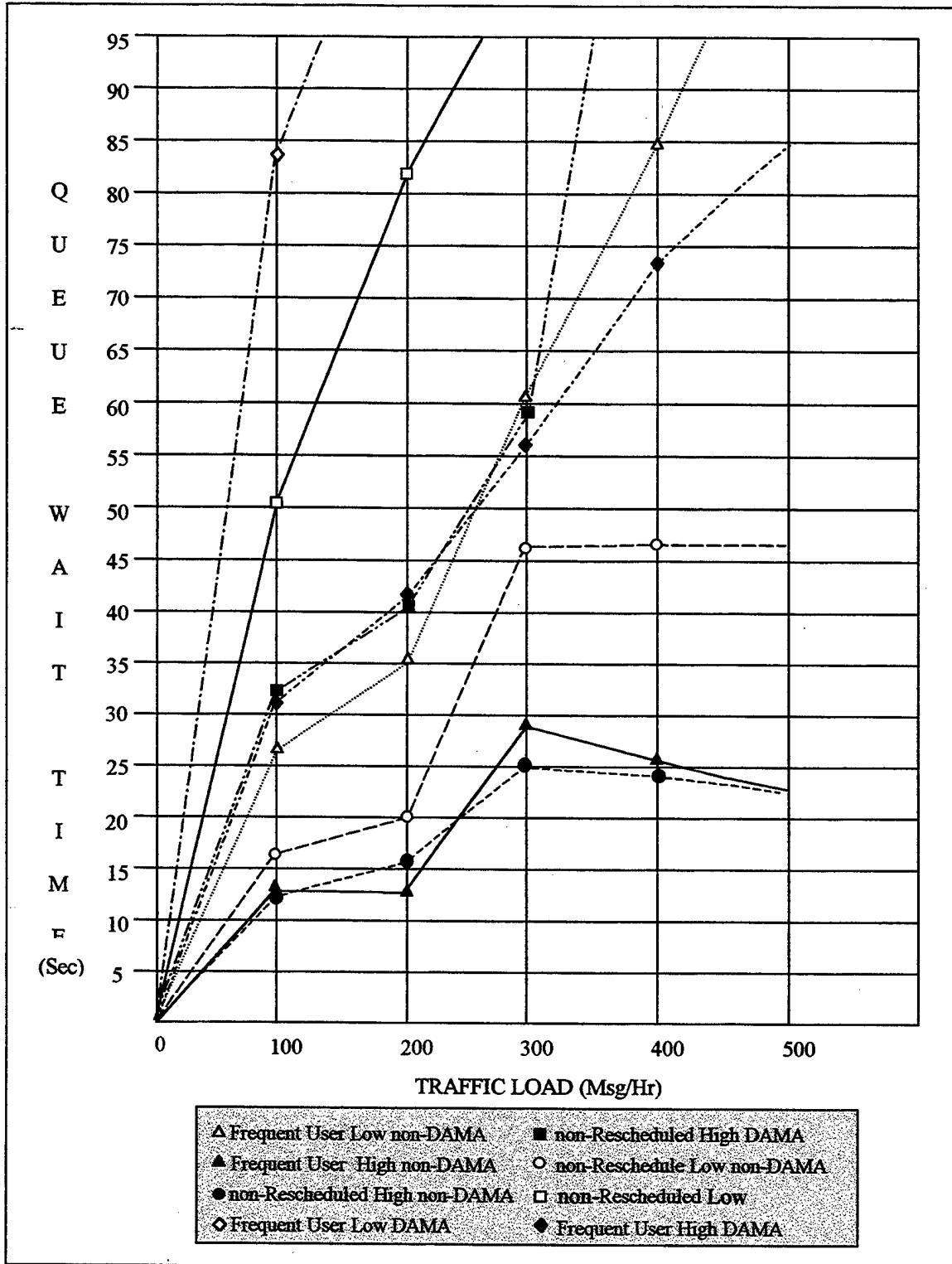

Figure C3-11. OTCIXS II Maximum: non-Rescheduled vs. Frequent User Queue Wait Time

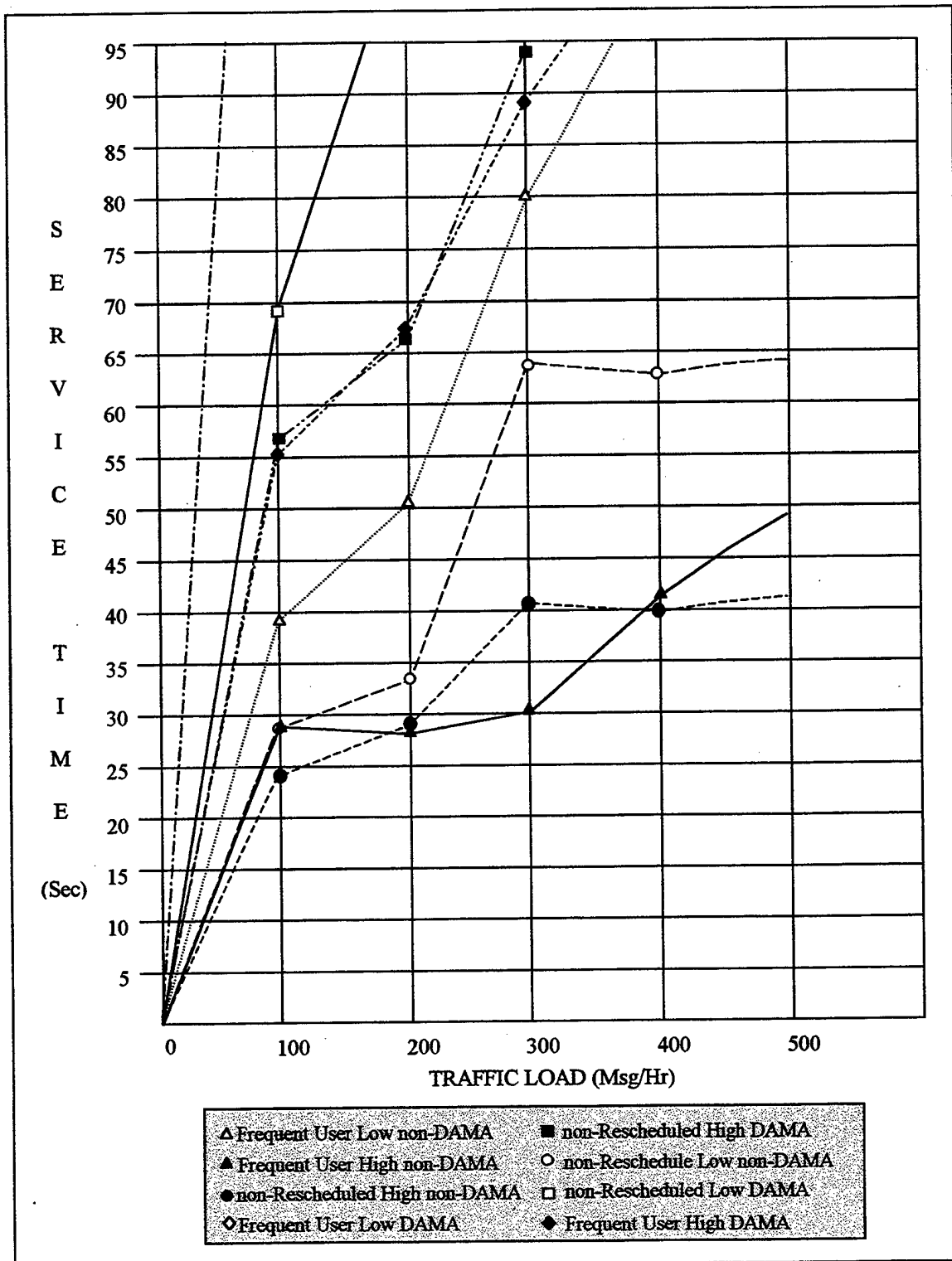

Figure C3-12. OTCIXS II Maximum: non-Rescheduled vs. Frequent User Service Time

THIS PAGE INTENTIONALLY LEFT BLANK

APPENDIX C - SECTION C4

OTCIXS MODEL NETWORK DESCRIPTION

The following is the source descriptions used to produce the OTCIXS network description file (NDF). This source was converted to the binary NDF using the OCTEDT program developed by Advanced Digital Systems (ADS).

ISECT

```
NETWORK = OTCIXS;  
DATE = "4 MAY 1999"  
SCENARIO = 1;
```

ENDS;

MSECT

```
DEFINE MESSAGE = TTYA;  
TYPE = TTY;  
SELECT PRECEDENCE = (<1:0.8>, <2:0.2>);  
SELECT COLLECTIVE = (<128:0.18>, <129:0.17>, <130:0.17>, <131:0.16>,  
                    <132:0.16>, <133:0.16>);  
SELECT NADRPM = (<1:0.9>, <2:0.08>, <3:0.02>);  
SELECT LENGTH = (< 100:0.10>, < 500:0.03>, < 550:0.05>, < 600:0.07>,  
                < 650:0.09>, < 700:0.10>, < 800:9.11>, < 900:0.10>,  
                < 1000:0.09>, < 1200:0.06>, < 1400:0.05>, < 1600:0.04>,  
                < 1800:0.02>, < 2000:0.01>, < 2500:0.01>, < 3000:0.02>,  
                < 4000:0.02>, < 6000:0.01>, < 7000:0.01>, < 8000:0.01>);
```

ENDDEF;

```
DEFINE MESSAGE = TDPA;  
TYPE = DATA;  
COPY TTYA.PRECEDENCE;  
COPY TTYA.COLLECTIVE;  
COPY TTYA.NADRPM;  
SELECT LENGTH = (< 100:0.10>, < 500:0.08>, < 600:0.07>, < 650:0.09>,  
                < 700:0.10>, < 800:0.11>, < 900:9.10>, < 1000:0.09>,  
                < 1200:0.06>, < 1400:0.05>, < 1600:0.04>, < 1800:0.02>,  
                < 2000:0.01>, < 2500:0.01>, < 3000:0.01>, < 4000:0.02>,  
                < 6000:0.01>, < 7000:0.01>, < 8000:0.01>, <10000:0.01>);
```

ENDDEF;

ENDS;

NSECT

```
DEFINE PLATFORM = AA01;
```

```

TYPE = SHORE;
SID = 1;

DEFINE DEVICE = TTY;
    CHANNEL = (75.0, 7.5, 0.00001, 0);
ENDDEF;

DEFINE DEVICE = TDP;
    CHANNEL = (4800.0, 8.0, 0.0001, 1);
ENDDEF;

DECLAIR SLCPARAM
    MAXMEM = 32367;
    PENALTY = 0.001;
    GUARD = (128);
    NOISE = BURST (20.0, 0.03, 8.0, 12.0);
    CLASS = TYPE1;
ENDP;
ENDDEF;

DEFINE PLATFORM = AA02;
    TYPE = SHIP;
    SID = 2;
    COPY AA01.DEVICE.TTY;
    COPY A001.DEVICE.TDP;
    DECLARE SLCPARAM;
        MAXMEM = 32367;
        PENALTY = 0.002;
        GUARD = (129);
        NOISE = BURST (12.0, 0.05, 8.0, 12.0);
        CLASS = TYPE2;
    ENDP;
ENDDEF;

DEFINE PLATFORM = AA03;
    TYPE = SHIP;
    SID = 3;
    COPY AA01.DEVICE.TTY;
    COPY A001.DEVICE.TDP;
    COPY A002.SLCPARAM;
    DECLARE SLCPARAM;
        GUARD = (130);
    ENDP;
ENDDEF;

DEFINE PLATFORM = AA04;
    TYPE = SHIP;
    SID = 4;
    COPY AA01.DEVICE.TTY;
    COPY A001.DEVICE.TDP;
    COPY A002.SLCPARAM;
    DECLARE SLCPARAM

```

```
        GUARD = (131);
        NOISE = BURST (10.0, 0.08, 8.0, 12.0);
        CLASS = TYPE1;
    ENDP;
ENDDEF;
```

```
DEFINE PLATFORM = AA05;
    TYPE = SHIP;
    SID = 5;
    COPY AA01.DEVICE.TTY;
    COPY A001.DEVICE.TDP;
    COPY A002.SLCPARAM;
    DECLARE SLCPARAM
        GUARD = (132);
    ENDP;
ENDDEF;
```

```
DEFINE PLATFORM = AA06;
    TYPE = SHIP;
    SID = 6;
    COPY AA01.DEVICE.TTY;
    COPY A001.DEVICE.TDP;
    COPY A002.SLCPARAM;
    DECLARE SLCPARAM
        GUARD = (133);
    ENDP;
ENDDEF;
```

```
DEFINE PLATFORM = AA07;
    TYPE = SHIP;
    SID = 7;
    COPY AA01.DEVICE.TTY;
    COPY A001.DEVICE.TDP;
    COPY A002.SLCPARAM;
    DECLARE SLCPARAM
        GUARD = (128);
        PENALTY = 0.002;
        CLASS = TYPE3;
    ENDP;
ENDDEF;
```

```
DEFINE PLATFORM = AA08;
    TYPE = SHIP;
    SID = 8;
    COPY AA01.DEVICE.TTY;
    COPY A001.DEVICE.TDP;
    COPY A002.SLCPARAM;
    DECLARE SLCPARAM
        GUARD = (129);
        PENALTY = 0.007;
        CLASS = TYPE3;
    ENDP;
```

ENDDEF;

```
DEFINE PLATFORM = AA09;  
  TYPE = SHIP;  
  SID = 9;  
  COPY AA01.DEVICE.TTY;  
  COPY A001.DEVICE.TDP;  
  COPY A002.SLCPARAM;  
  DECLARE SLCPARAM  
    GUARD = (130);  
    PENALTY = 0.002;  
    CLASS = TYPE3;  
  ENDP;  
ENDDEF;
```

```
DEFINE PLATFORM = AA10;  
  TYPE = SHIP;  
  SID = 10;  
  COPY AA01.DEVICE.TTY;  
  COPY A001.DEVICE.TDP;  
  COPY A002.SLCPARAM;  
  DECLARE SLCPARAM  
    GUARD = (131);  
    PENALTY = 0.001;  
    CLASS = TYPE3;  
  ENDP;  
ENDDEF;
```

```
DEFINE PLATFORM = AA11;  
  TYPE = SHIP;  
  SID = 11;  
  COPY AA01.DEVICE.TTY;  
  COPY A001.DEVICE.TDP;  
  COPY A002.SLCPARAM;  
  DECLARE SLCPARAM  
    GUARD = (132);  
    PENALTY = 0.002;  
    CLASS = TYPE3;  
  ENDP;  
ENDDEF;
```

```
DEFINE PLATFORM = AA12;  
  TYPE = SHIP;  
  SID = 12;  
  COPY AA01.DEVICE.TTY;  
  COPY A001.DEVICE.TDP;  
  COPY A002.SLCPARAM;  
  DECLARE SLCPARAM  
    GUARD = (133);  
    PENALTY = 0.002;  
    CLASS = TYPE3;
```

ENDP;
ENDDEF;

DEFINE PLATFORM = AA13;
TYPE = SHIP;
SID = 13;
COPY AA01.DEVICE.TTY;
COPY A001.DEVICE.TDP;
COPY A002.SLCPARAM;
DECLARE SLCPARAM
GUARD = (128);
PENALTY = 0.001;
CLASS = TYPE3;
ENDP;
ENDDEF;

DEFINE PLATFORM = AA14;
TYPE = SHIP;
SID = 14;
COPY AA01.DEVICE.TTY;
COPY A001.DEVICE.TDP;
COPY A002.SLCPARAM;
DECLARE SLCPARAM
GUARD = (129);
PENALTY = 0.001;
ENDP;
ENDDEF;

DEFINE PLATFORM = AA15;
TYPE = SHIP;
SID = 15;
COPY AA01.DEVICE.TTY;
COPY A001.DEVICE.TDP;
COPY A002.SLCPARAM;
DECLARE SLCPARAM
GUARD = (130);
PENALTY = 0.002;
CLASS = TYPE3;
ENDP;
ENDDEF;

DEFINE PLATFORM = AA16;
TYPE = SHIP;
SID = 16;
COPY AA01.DEVICE.TTY;
COPY A001.DEVICE.TDP;
COPY A002.SLCPARAM;
DECLARE SLCPARAM
GUARD = (131);
PENALTY = 0.001;
CLASS = TYPE3;
ENDP;
ENDDEF;

```
DEFINE PLATFORM = AA17;
  TYPE = SHIP;
  SID = 17;
  COPY AA01.DEVICE.TTY;
  COPY A001.DEVICE.TDP;
  COPY A002.SLCPARAM;
  DECLARE SLCPARAM
    GUARD = (132);
    PENALTY = 0.002;
    CLASS = TYPE3;
  ENDP;
ENDDEF;
```

```
DEFINE PLATFORM = AA18;
  TYPE = SHIP;
  SID = 18;
  COPY AA01.DEVICE.TTY;
  COPY A001.DEVICE.TDP;
  COPY A002.SLCPARAM;
  DECLARE SLCPARAM
    GUARD = (133);
    PENALTY = 0.001;
  ENDP;
ENDDEF;
```

```
DEFINE PLATFORM = AA19;
  TYPE = SHIP;
  SID = 19;
  COPY AA01.DEVICE.TTY;
  COPY A001.DEVICE.TDP;
  COPY A002.SLCPARAM;
  DECLARE SLCPARAM
    GUARD = (128);
  ENDP;
ENDDEF;
```

```
DEFINE PLATFORM = AA20;
  TYPE = SHIP;
  SID = 20;
  COPY AA01.DEVICE.TTY;
  COPY A001.DEVICE.TDP;
  COPY A002.SLCPARAM;
  DECLARE SLCPARAM
    GUARD = (129);
    PENALTY = 0.002;
    CLASS = TYPE3;
  ENDP;
ENDDEF;
```

```
DEFINE PLATFORM = AA21;
  TYPE = SHIP;
  SID = 21;
  COPY AA01.DEVICE.TTY;
```

```
COPY A001.DEVICE.TDP;
COPY A002.SLCPARAM;
DECLARE SLCPARAM
    GUARD = (130);
    CLASS = TYPE3;
ENDP;
ENDDEF;
```

```
DEFINE PLATFORM = AA22;
    TYPE = SHIP;
    SID = 22;
    COPY AA01.DEVICE.TTY;
    COPY A001.DEVICE.TDP;
    COPY A002.SLCPARAM;
    DECLARE SLCPARAM
        GUARD = (131);
        CLASS = TYPE3;
    ENDP;
    ENDDEF;
```

```
DEFINE PLATFORM = AA23;
    TYPE = SHIP;
    SID = 23;
    COPY AA01.DEVICE.TTY;
    COPY A001.DEVICE.TDP;
    COPY A002.SLCPARAM;
    DECLARE SLCPARAM
        GUARD = (132);
        CLASS = TYPE3;
    ENDP;
    ENDDEF;
```

```
DEFINE PLATFORM = AA24;
    TYPE = SHIP;
    SID = 24;
    COPY AA01.DEVICE.TTY;
    COPY A001.DEVICE.TDP;
    COPY A002.SLCPARAM;
    DECLARE SLCPARAM
        GUARD = (133);
        PENTALTY = 0.002;
        CLASS = TYPE3;
    ENDP;
    ENDDEF;
```

```
DEFINE PLATFORM = AA25;
    TYPE = SHIP;
    SID = 25;
    COPY AA01.DEVICE.TTY;
    COPY A001.DEVICE.TDP;
    COPY A002.SLCPARAM;
    DECLARE SLCPARAM
        GUARD = (128);
```

```
        PENTALTY = 0.002;  
        CLASS = TYPE3;  
ENDP;  
ENDDEF;
```

```
DEFINE PLATFORM = AA26;  
    TYPE = SHIP;  
    SID = 26;  
    COPY AA01.DEVICE.TTY;  
    COPY A001.DEVICE.TDP;  
    COPY A002.SLCPARAM;  
    DECLARE SLCPARAM  
        GUARD = (129);  
        CLASS = TYPE3;  
ENDP;  
ENDDEF;
```

```
DEFINE PLATFORM = AA27;  
    TYPE = SHIP;  
    SID = 27;  
    COPY AA01.DEVICE.TTY;  
    COPY A001.DEVICE.TDP;  
    COPY A002.SLCPARAM;  
    DECLARE SLCPARAM  
        GUARD = (130);  
        PENALTY = 0.001;  
        CLASS = TYPE3;  
ENDP;  
ENDDEF;
```

```
DEFINE PLATFORM = AA28;  
    TYPE = SHIP;  
    SID = 28;  
    COPY AA01.DEVICE.TTY;  
    COPY A001.DEVICE.TDP;  
    COPY A002.SLCPARAM;  
    DECLARE SLCPARAM  
        GUARD = (131);  
        CLASS = TYPE3;  
ENDP;  
ENDDEF;
```

```
DEFINE PLATFORM = AA29;  
    TYPE = SHIP;  
    SID = 29;  
    COPY AA01.DEVICE.TTY;  
    COPY A001.DEVICE.TDP;  
    COPY A002.SLCPARAM;  
    DECLARE SLCPARAM  
        GUARD = (132);  
        CLASS = TYPE3;  
ENDP;  
ENDDEF;
```

```

DEFINE PLATFORM = AA30;
    TYPE = SHIP;
    SID = 30;
    COPY AA01.DEVICE.TTY;
    COPY A001.DEVICE.TDP;
    COPY A002.SLCPARAM;
    DECLARE SLCPARAM
        GUARD = (133);
        CLASS = TYPE3;
    ENDP;
    ENDDEF;

DEFINE PLATFORM = AA31;
    TYPE = SHIP;
    SID = 31;
    COPY AA01.DEVICE.TTY;
    COPY A001.DEVICE.TDP;
    COPY A002.SLCPARAM;
    DECLARE SLCPARAM
        GUARD = (128);
        CLASS = TYPE3;
    ENDP;
    ENDDEF;

DEFINE PLATFORM = AA32;
    TYPE = SHIP;
    SID = 32;
    COPY AA01.DEVICE.TTY;
    COPY A001.DEVICE.TDP;
    COPY A002.SLCPARAM;
    DECLARE SLCPARAM
        GUARD = (129);
        PENALTY = 0.002;
        CLASS = TYPE3;
    ENDP;
    ENDDEF;

DEFINE PLATFORM = AA33;
    TYPE = SHIP;
    SID = 33;
    COPY AA01.DEVICE.TTY;
    COPY A001.DEVICE.TDP;
    COPY A002.SLCPARAM;
    DECLARE SLCPARAM
        GUARD = (133);
        CLASS = TYPE3;
    ENDP;
    ENDDEF;

DEFINE PLATFORM = AA34;
    TYPE = SHIP;
    SID = 34;
    COPY AA01.DEVICE.TTY;

```

```
COPY A001.DEVICE.TDP;
COPY A002.SLCPARAM;
DECLARE SLCPARAM
    GUARD = (131);
    PENALTY = 0.001;
    CLASS = TYPE3;
ENDP;
ENDDEF;
```

```
DEFINE PLATFORM = AA35;
    TYPE = SHIP;
    SID = 35;
    COPY AA01.DEVICE.TTY;
    COPY A001.DEVICE.TDP;
    COPY A002.SLCPARAM;
    DECLARE SLCPARAM
        GUARD = (132);
        CLASS = TYPE3;
    ENDP;
    ENDDEF;
```

```
DEFINE PLATFORM = AA36;
    TYPE = SHIP;
    SID = 36;
    COPY AA01.DEVICE.TTY;
    COPY A001.DEVICE.TDP;
    COPY A002.SLCPARAM;
    DECLARE SLCPARAM
        GUARD = (133);
        CLASS = TYPE3;
    ENDP;
    ENDDEF;
```

```
DEFINE PLATFORM = AA37;
    TYPE = SHIP;
    SID = 37;
    COPY AA01.DEVICE.TTY;
    COPY A001.DEVICE.TDP;
    COPY A002.SLCPARAM;
    DECLARE SLCPARAM
        GUARD = (132);
        PENALTY = 0.008;
        CLASS = TYPE3;
    ENDP;
    ENDDEF;
```

```
DEFINE PLATFORM = AA38;
    TYPE = SHIP;
    SID = 38;
    COPY AA01.DEVICE.TTY;
    COPY A001.DEVICE.TDP;
    COPY A002.SLCPARAM;
    DECLARE SLCPARAM
```

```

        GUARD = (131);
        CLASS = TYPE3;
    ENDP;
    ENDDEF;

DEFINE PLATFORM = AA39;
    TYPE = SHIP;
    SID = 39;
    COPY AA01.DEVICE.TTY;
    COPY A001.DEVICE.TDP;
    COPY A002.SLCPARAM;
    DECLARE SLCPARAM
        GUARD = (130);
        NOISE = BURST(6.0, 0.8, 5.0, 6.3);
        CLASS = TYPE3;
    ENDP;
    ENDDEF;

DEFINE PLATFORM = AA40;
    TYPE = SHIP;
    SID = 40;
    COPY AA01.DEVICE.TTY;
    COPY A001.DEVICE.TDP;
    COPY A002.SLCPARAM;
    DECLARE SLCPARAM
        GUARD = (129);
        CLASS = TYPE3;
    ENDP;
    ENDDEF;

ENDS;

DECLARE SOURCE
PLATFORM = AA01;
DEVICE = TDP;
MSG = TDPA;
USE DISCRETE = 0.25;
SELCET DISCRETE = *;
SELECT COLLECTIVE = (<1:0.9>,<2:0.08>,<3::0.02>);
SELECT NADRPM = (<1:0.09>,<2:0.08>,<3:0.02>);
ARRIVALS = POISSON(0.21);
    ENDP;

DECLARE SOURCE
PLATFORM = AA01;
DEVICE = TTY;
MSG = TTYA;
USE DISCRETE = 0.25;
SELCET DISCRETE = *;
SELECT COLLECTIVE = (<1:0.9>,<2:0.08>,<3::0.02>);
SELECT NADRPM = (<1:0.09>,<2:0.08>,<3:0.02>);
ARRIVALS = POISSON(0.34);

```

ENDP;

```
DECLARE SOURCE
PLATFORM = AA04;
DEVICE = TDP;
MSG = TDPA;
USE DISCRETE = 0.25;
SELCET DISCRETE = *;
SELECT COLLECTIVE = (<1:0.9>,<2:0.08>,<3::0.02>);
SELECT NADRPM = (<1:0.09>,<2:0.08>,<3:0.02>);
ARRIVALS = POISSON(0.09);
ENDP;
```

```
DECLARE SOURCE
PLATFORM = AA04;
DEVICE = TTY;
MSG = TTYA;
USE DISCRETE = 0.25;
SELCET DISCRETE = *;
SELECT COLLECTIVE = (<1:0.9>,<2:0.08>,<3::0.02>);
SELECT NADRPM = (<1:0.09>,<2:0.08>,<3:0.02>);
ARRIVALS = POISSON(0.025);
ENDP;
```

```
DECLARE SOURCE
PLATFORM = AA02;
DEVICE = TDP;
MSG = TDPA;
USE DISCRETE = 0.25;
SELCET DISCRETE = *;
SELECT COLLECTIVE = (<1:0.9>,<2:0.08>,<3::0.02>);
SELECT NADRPM = (<1:0.09>,<2:0.08>,<3:0.02>);
ARRIVALS = POISSON(0.10);
ENDP;
```

```
DECLARE SOURCE
PLATFORM = AA02;
DEVICE = TTY;
MSG = TTYA;
USE DISCRETE = 0.25;
SELCET DISCRETE = *;
SELECT COLLECTIVE = (<1:0.9>,<2:0.08>,<3::0.02>);
SELECT NADRPM = (<1:0.09>,<2:0.08>,<3:0.02>);
ARRIVALS = POISSON(0.01);
ENDP;
```

```
DECLARE SOURCE
PLATFORM = AA03;
DEVICE = TDP;
MSG = TDPA;
USE DISCRETE = 0.25;
SELCET DISCRETE = *;
SELECT COLLECTIVE = (<1:0.9>,<2:0.08>,<3::0.02>);
```

```
SELECT NADRPM = (<1:0.09>,<2:0.08>,<3:0.02>):  
ARRIVALS = POISSON(0.14);  
ENDP;
```

```
DECLARE SOURCE  
PLATFORM = AA03;  
DEVICE = TTY;  
MSG = TTYA;  
USE DISCRETE = 0.25;  
SELCET DISCRETE = *;  
SELECT COLLECTIVE = (<1:0.9>,<2:0.08>,<3::0.02>);  
SELECT NADRPM = (<1:0.09>,<2:0.08>,<3:0.02>):  
ARRIVALS = POISSON(0.009);  
ENDP;
```

```
DECLARE SOURCE  
PLATFORM = AA05;  
DEVICE = TDP;  
MSG = TDPA;  
USE DISCRETE = 0.25;  
SELCET DISCRETE = *;  
SELECT COLLECTIVE = (<1:0.9>,<2:0.08>,<3::0.02>);  
SELECT NADRPM = (<1:0.09>,<2:0.08>,<3:0.02>):  
ARRIVALS = POISSON(0.07);  
ENDP;
```

```
DECLARE SOURCE  
PLATFORM = AA05;  
DEVICE = TTY;  
MSG = TTYA;  
USE DISCRETE = 0.25;  
SELCET DISCRETE = *;  
SELECT COLLECTIVE = (<1:0.9>,<2:0.08>,<3::0.02>);  
SELECT NADRPM = (<1:0.09>,<2:0.08>,<3:0.02>):  
ARRIVALS = POISSON(0.009);  
ENDP;
```

```
DECLARE SOURCE  
PLATFORM = AA06;  
DEVICE = TDP;  
MSG = TDPA;  
USE DISCRETE = 0.25;  
SELCET DISCRETE = *;  
SELECT COLLECTIVE = (<1:0.9>,<2:0.08>,<3::0.02>);  
SELECT NADRPM = (<1:0.09>,<2:0.08>,<3:0.02>):  
ARRIVALS = POISSON(0.08);  
ENDP;
```

```
DECLARE SOURCE  
PLATFORM = AA06;  
DEVICE = TTY;  
MSG = TTYA;  
USE DISCRETE = 0.25;
```

```
SELCET DISCRETE = *;  
SELECT COLLECTIVE = (<1:0.9>,<2:0.08>,<3::0.02>);  
SELECT NADRPM = (<1:0.09>,<2:0.08>,<3:0.02>):  
ARRIVALS = POISSON(0.009);  
ENDP;
```

```
DECLARE SOURCE  
PLATFORM = AA13;  
DEVICE = TDP;  
MSG = TDPA;  
USE DISCRETE = 0.25;  
SELCET DISCRETE = *;  
SELECT COLLECTIVE = (<1:0.9>,<2:0.08>,<3::0.02>);  
SELECT NADRPM = (<1:0.09>,<2:0.08>,<3:0.02>):  
ARRIVALS = POISSON(0.20);  
ENDP;
```

```
DECLARE SOURCE  
PLATFORM = AA13;  
DEVICE = TTY;  
MSG = TTYA;  
USE DISCRETE = 0.25;  
SELCET DISCRETE = *;  
SELECT COLLECTIVE = (<1:0.9>,<2:0.08>,<3::0.02>);  
SELECT NADRPM = (<1:0.09>,<2:0.08>,<3:0.02>):  
ARRIVALS = POISSON(0.009);  
ENDP;
```

```
DECLARE SOURCE  
PLATFORM = AA14;  
DEVICE = TDP;  
MSG = TDPA;  
USE DISCRETE = 0.25;  
SELCET DISCRETE = *;  
SELECT COLLECTIVE = (<1:0.9>,<2:0.08>,<3::0.02>);  
SELECT NADRPM = (<1:0.09>,<2:0.08>,<3:0.02>):  
ARRIVALS = POISSON(0.25);  
ENDP;
```

```
DECLARE SOURCE  
PLATFORM = AA18;  
DEVICE = TTY;  
MSG = TTYA;  
USE DISCRETE = 0.25;  
SELCET DISCRETE = *;  
SELECT COLLECTIVE = (<1:0.9>,<2:0.08>,<3::0.02>);  
SELECT NADRPM = (<1:0.09>,<2:0.08>,<3:0.02>):  
ARRIVALS = POISSON(0.025);  
ENDP;
```

```
DECLARE SOURCE  
PLATFORM = AA19;  
DEVICE = TDP;
```

```
MSG = TDPA;
USE DISCRETE = 0.25;
SELCET DISCRETE = *;
SELECT COLLECTIVE = (<1:0.9>,<2:0.08>,<3::0.02>);
SELECT NADRPM = (<1:0.09>,<2:0.08>,<3:0.02>);
ARRIVALS = POISSON(0.025);
    ENDP;
```

```
DECLARE SOURCE
PLATFORM = AA07;
DEVICE = TDP;
MSG = TDPA;
USE DISCRETE = 0.25;
SELCET DISCRETE = *;
SELECT COLLECTIVE = (<1:0.9>,<2:0.08>,<3::0.02>);
SELECT NADRPM = (<1:0.09>,<2:0.08>,<3:0.02>);
ARRIVALS = POISSON(0.003);
    ENDP;
```

```
DECLARE SOURCE
PLATFORM = AA08;
DEVICE = TDP;
MSG = TDPA;
USE DISCRETE = 0.25;
SELCET DISCRETE = *;
SELECT COLLECTIVE = (<1:0.9>,<2:0.08>,<3::0.02>);
SELECT NADRPM = (<1:0.09>,<2:0.08>,<3:0.02>);
ARRIVALS = POISSON(0.003);
    ENDP;
```

```
DECLARE SOURCE
PLATFORM = AA09;
DEVICE = TDP;
MSG = TDPA;
USE DISCRETE = 0.25;
SELCET DISCRETE = *;
SELECT COLLECTIVE = (<1:0.9>,<2:0.08>,<3::0.02>);
SELECT NADRPM = (<1:0.09>,<2:0.08>,<3:0.02>);
ARRIVALS = POISSON(0.003);
    ENDP;
```

```
DECLARE SOURCE
PLATFORM = AA10;
DEVICE = TDP;
MSG = TDPA;
USE DISCRETE = 0.25;
SELCET DISCRETE = *;
SELECT COLLECTIVE = (<1:0.9>,<2:0.08>,<3::0.02>);
SELECT NADRPM = (<1:0.09>,<2:0.08>,<3:0.02>);
ARRIVALS = POISSON(0.003);
    ENDP;
```

```
DECLARE SOURCE
```

```
PLATFORM = AA11;
DEVICE = TDP;
MSG = TDPA;
USE DISCRETE = 0.25;
SELCET DISCRETE = *;
SELECT COLLECTIVE = (<1:0.9>,<2:0.08>,<3::0.02>);
SELECT NADRPM = (<1:0.09>,<2:0.08>,<3:0.02>);
ARRIVALS = POISSON(0.003);
        ENDP;
```

```
DECLARE SOURCE
PLATFORM = AA12;
DEVICE = TDP;
MSG = TDPA;
USE DISCRETE = 0.25;
SELCET DISCRETE = *;
SELECT COLLECTIVE = (<1:0.9>,<2:0.08>,<3::0.02>);
SELECT NADRPM = (<1:0.09>,<2:0.08>,<3:0.02>);
ARRIVALS = POISSON(0.003);
        ENDP;
```

```
DECLARE SOURCE
PLATFORM = AA15;
DEVICE = TDP;
MSG = TDPA;
USE DISCRETE = 0.25;
SELCET DISCRETE = *;
SELECT COLLECTIVE = (<1:0.9>,<2:0.08>,<3::0.02>);
SELECT NADRPM = (<1:0.09>,<2:0.08>,<3:0.02>);
ARRIVALS = POISSON(0.003);
        ENDP;
```

```
DECLARE SOURCE
PLATFORM = AA16;
DEVICE = TDP;
MSG = TDPA;
USE DISCRETE = 0.25;
SELCET DISCRETE = *;
SELECT COLLECTIVE = (<1:0.9>,<2:0.08>,<3::0.02>);
SELECT NADRPM = (<1:0.09>,<2:0.08>,<3:0.02>);
ARRIVALS = POISSON(0.003);
        ENDP;
```

```
DECLARE SOURCE
PLATFORM = AA17;
DEVICE = TDP;
MSG = TDPA;
USE DISCRETE = 0.25;
SELCET DISCRETE = *;
SELECT COLLECTIVE = (<1:0.9>,<2:0.08>,<3::0.02>);
SELECT NADRPM = (<1:0.09>,<2:0.08>,<3:0.02>);
ARRIVALS = POISSON(0.003);
        ENDP;
```

```
DECLARE SOURCE
PLATFORM = AA20;
DEVICE = TDP;
MSG = TDPA;
USE DISCRETE = 0.25;
SELCET DISCRETE = *;
SELECT COLLECTIVE = (<1:0.9>,<2:0.08>,<3::0.02>);
SELECT NADRPM = (<1:0.09>,<2:0.08>,<3:0.02>);
ARRIVALS = POISSON(0.003);
    ENDP;
```

```
DECLARE SOURCE
PLATFORM = AA21;
DEVICE = TDP;
MSG = TDPA;
USE DISCRETE = 0.25;
SELCET DISCRETE = *;
SELECT COLLECTIVE = (<1:0.9>,<2:0.08>,<3::0.02>);
SELECT NADRPM = (<1:0.09>,<2:0.08>,<3:0.02>);
ARRIVALS = POISSON(0.003);
    ENDP;
```

```
DECLARE SOURCE
PLATFORM = AA22;
DEVICE = TDP;
MSG = TDPA;
USE DISCRETE = 0.25;
SELCET DISCRETE = *;
SELECT COLLECTIVE = (<1:0.9>,<2:0.08>,<3::0.02>);
SELECT NADRPM = (<1:0.09>,<2:0.08>,<3:0.02>);
ARRIVALS = POISSON(0.003);
    ENDP;
```

```
DECLARE SOURCE
PLATFORM = AA23;
DEVICE = TDP;
MSG = TDPA;
USE DISCRETE = 0.25;
SELCET DISCRETE = *;
SELECT COLLECTIVE = (<1:0.9>,<2:0.08>,<3::0.02>);
SELECT NADRPM = (<1:0.09>,<2:0.08>,<3:0.02>);
ARRIVALS = POISSON(0.003);
    ENDP;
```

```
DECLARE SOURCE
PLATFORM = AA24;
DEVICE = TDP;
MSG = TDPA;
USE DISCRETE = 0.25;
SELCET DISCRETE = *;
SELECT COLLECTIVE = (<1:0.9>,<2:0.08>,<3::0.02>);
SELECT NADRPM = (<1:0.09>,<2:0.08>,<3:0.02>);
ARRIVALS = POISSON(0.003);
```

ENDP;

```
DECLARE SOURCE
PLATFORM = AA25;
DEVICE = TDP;
MSG = TDPA;
USE DISCRETE = 0.25;
SELCET DISCRETE = *;
SELECT COLLECTIVE = (<1:0.9>,<2:0.08>,<3::0.02>);
SELECT NADRPM = (<1:0.09>,<2:0.08>,<3:0.02>);
ARRIVALS = POISSON(0.003);
ENDP;
```

```
DECLARE SOURCE
PLATFORM = AA26;
DEVICE = TDP;
MSG = TDPA;
USE DISCRETE = 0.25;
SELCET DISCRETE = *;
SELECT COLLECTIVE = (<1:0.9>,<2:0.08>,<3::0.02>);
SELECT NADRPM = (<1:0.09>,<2:0.08>,<3:0.02>);
ARRIVALS = POISSON(0.003);
ENDP;
```

```
DECLARE SOURCE
PLATFORM = AA27;
DEVICE = TDP;
MSG = TDPA;
USE DISCRETE = 0.25;
SELCET DISCRETE = *;
SELECT COLLECTIVE = (<1:0.9>,<2:0.08>,<3::0.02>);
SELECT NADRPM = (<1:0.09>,<2:0.08>,<3:0.02>);
ARRIVALS = POISSON(0.003);
ENDP;
```

```
DECLARE SOURCE
PLATFORM = AA28;
DEVICE = TDP;
MSG = TDPA;
USE DISCRETE = 0.25;
SELCET DISCRETE = *;
SELECT COLLECTIVE = (<1:0.9>,<2:0.08>,<3::0.02>);
SELECT NADRPM = (<1:0.09>,<2:0.08>,<3:0.02>);
ARRIVALS = POISSON(0.003);
ENDP;
```

```
DECLARE SOURCE
PLATFORM = AA29;
DEVICE = TDP;
MSG = TDPA;
USE DISCRETE = 0.25;
SELCET DISCRETE = *;
SELECT COLLECTIVE = (<1:0.9>,<2:0.08>,<3::0.02>);
```

```
SELECT NADRPM = (<1:0.09>,<2:0.08>,<3:0.02>);
ARRIVALS = POISSON(0.003);
ENDP;
```

```
DECLARE SOURCE
PLATFORM = AA30;
DEVICE = TDP;
MSG = TDPA;
USE DISCRETE = 0.25;
SELCET DISCRETE = *;
SELECT COLLECTIVE = (<1:0.9>,<2:0.08>,<3::0.02>);
SELECT NADRPM = (<1:0.09>,<2:0.08>,<3:0.02>);
ARRIVALS = POISSON(0.003);
ENDP;
```

```
DECLARE SOURCE
PLATFORM = AA31;
DEVICE = TDP;
MSG = TDPA;
USE DISCRETE = 0.25;
SELCET DISCRETE = *;
SELECT COLLECTIVE = (<1:0.9>,<2:0.08>,<3::0.02>);
SELECT NADRPM = (<1:0.09>,<2:0.08>,<3:0.02>);
ARRIVALS = POISSON(0.003);
ENDP;
```

```
DECLARE SOURCE
PLATFORM = AA32;
DEVICE = TDP;
MSG = TDPA;
USE DISCRETE = 0.25;
SELCET DISCRETE = *;
SELECT COLLECTIVE = (<1:0.9>,<2:0.08>,<3::0.02>);
SELECT NADRPM = (<1:0.09>,<2:0.08>,<3:0.02>);
ARRIVALS = POISSON(0.003);
ENDP;
```

```
DECLARE SOURCE
PLATFORM = AA33;
DEVICE = TDP;
MSG = TDPA;
USE DISCRETE = 0.25;
SELCET DISCRETE = *;
SELECT COLLECTIVE = (<1:0.9>,<2:0.08>,<3::0.02>);
SELECT NADRPM = (<1:0.09>,<2:0.08>,<3:0.02>);
ARRIVALS = POISSON(0.003);
ENDP;
```

```
DECLARE SOURCE
PLATFORM = AA34;
DEVICE = TDP;
MSG = TDPA;
USE DISCRETE = 0.25;
```

```
SELCET DISCRETE = *;  
SELECT COLLECTIVE = (<1:0.9>,<2:0.08>,<3::0.02>);  
SELECT NADRPM = (<1:0.09>,<2:0.08>,<3:0.02>);  
ARRIVALS = POISSON(0.003);  
ENDP;
```

```
DECLARE SOURCE  
PLATFORM = AA35;  
DEVICE = TDP;  
MSG = TDPA;  
USE DISCRETE = 0.25;  
SELCET DISCRETE = *;  
SELECT COLLECTIVE = (<1:0.9>,<2:0.08>,<3::0.02>);  
SELECT NADRPM = (<1:0.09>,<2:0.08>,<3:0.02>);  
ARRIVALS = POISSON(0.003);  
ENDP;
```

```
DECLARE SOURCE  
PLATFORM = AA36;  
DEVICE = TDP;  
MSG = TDPA;  
USE DISCRETE = 0.25;  
SELCET DISCRETE = *;  
SELECT COLLECTIVE = (<1:0.9>,<2:0.08>,<3::0.02>);  
SELECT NADRPM = (<1:0.09>,<2:0.08>,<3:0.02>);  
ARRIVALS = POISSON(0.003);  
ENDP;
```

```
DECLARE SOURCE  
PLATFORM = AA37;  
DEVICE = TDP;  
MSG = TDPA;  
USE DISCRETE = 0.25;  
SELCET DISCRETE = *;  
SELECT COLLECTIVE = (<1:0.9>,<2:0.08>,<3::0.02>);  
SELECT NADRPM = (<1:0.09>,<2:0.08>,<3:0.02>);  
ARRIVALS = POISSON(0.003);  
ENDP;
```

```
DECLARE SOURCE  
PLATFORM = AA38;  
DEVICE = TDP;  
MSG = TDPA;  
USE DISCRETE = 0.25;  
SELCET DISCRETE = *;  
SELECT COLLECTIVE = (<1:0.9>,<2:0.08>,<3::0.02>);  
SELECT NADRPM = (<1:0.09>,<2:0.08>,<3:0.02>);  
ARRIVALS = POISSON(0.003);  
ENDP;
```

```
DECLARE SOURCE  
PLATFORM = AA39;  
DEVICE = TDP;
```

```
MSG = TDPA;  
USE DISCRETE = 0.25;  
SELCET DISCRETE = *;  
SELECT COLLECTIVE = (<1:0.9>,<2:0.08>,<3::0.02>);  
SELECT NADRPM = (<1:0.09>,<2:0.08>,<3:0.02>);  
ARRIVALS = POISSON(0.003);  
    ENDP;
```

```
DECLARE SOURCE  
PLATFORM = AA40;  
DEVICE = TDP;  
MSG = TDPA;  
USE DISCRETE = 0.25;  
SELCET DISCRETE = *;  
SELECT COLLECTIVE = (<1:0.9>,<2:0.08>,<3::0.02>);  
SELECT NADRPM = (<1:0.09>,<2:0.08>,<3:0.02>);  
ARRIVALS = POISSON(0.003);  
    ENDP;
```

THIS PAGE INTENTIONALLY LEFT BLANK

APPENDIX D

OTCIXS II MODEL SIMULATION SETUP FILE FORMAT

A. INTRODUCTION.

The OTCIXS II simulation setup file is used to specify run time parameters. The network description file (NDF) specifies the network subscriber and traffic characteristics; the setup file identifies the environment characteristic for the subscribers. These characteristic include such items as which NDF to use, non-DAMA or DAMA (including the OTCIXS II DAMA model), the net control station, data block sizes, transfer rates and other types of environment parameters.

The setup file format allows the user to specify parameter data for several exercises. This feature allows for several variations of environmental characteristics to be run against one or more NDF definitions. Thus analysis of various types and methods of OTIXS link operations can be performed. The following subsections describe the format and contents of the setup file.

B. GENERAL FORMAT

The setup file is a text file using standard ASCII. Each record in the file has a one character record code identifier as its first non-blank character. The record code is followed by one or more blanks and then auxiliary information related to the record code. The general format of the setup file record is as follows:

C PARAM DATA

Where:

- C - Record Code
- PARAM - Parameter identifier (if any)
- DATA - Data (if any)

C. RECORD CODES

The following is a list of the record codes in the setup file.

RECORD CODE	DESCRIPTION
A	Enables OTCIXS II model. This code must be included in each exercise that runs an OTCIXS II model.
C	Specifies the Crypto synchronization up link and down link factors Enables DAMA model and DAMA bit error rates. This model runs the non-DAMA OTCIXS model using a DAMA transmit/receive device simulation. This model is different from the OTCIXS II model: the OTCIXS II model is a network protocol designed specifically to operate in a DAMA environment.
D	Specifies the name of the even history file. This record is required
E	Specifies subscriber to satellite DAMA signal strength (figure of merit (FOM)) characteristics based on three class types of subscribers such that type 1 subscribers have very good signal quality, type 2 subscribers have fair signal quality, and type 3 subscribers have poor quality signals. The subscriber with the best FOM value will override other subscribers when a transmit contention condition occurs.
F	Specifies the name of the NDF. This record is required.
I	This record specifies a traffic multiplier that is applied to all traffic sources. This value is multiplied to the rate factor in the NDF that specifies subscriber message traffic.
M	Title of the current simulation.
N	Specifies signal to noise values. Only one pair can be specified per record, and at least one record must be specified. However, these values only need to be defined once, and will be used by all succeeding exercises. If these values are not defined, those equations that use signal/noise values to compute transmission errors will produce erroneous results.
P	Specifies link environment parameters such as net control station, subscriber link data rate, etc.
Q	Specifies four values to be used as initial (seed) values for computing random numbers. These values must be specified at
R	

least the first time the simulation is run.

S Specified the scenario identifier and exercise identifier.

T Specifies the termination criteria for this exercise.

X Specifies the name of the summary file. This record is required.

/ The slash (/) character specifies the end of the parameters for a given exercise. Any parameters that follow will be used for the next exercise. This process continues until the end of setup file condition occurs. An end of file condition will terminate the simulation; thus, the last exercise should end with the slash character followed by the end of file.

D. SPECIFIC RECORD CODE FORMATS

a. OTCIXS II Enable

A

Note: the A stands for SATLINK-A; this is a carry over from the original program that referred to a new experimental protocol as SATLINK-A. This experimental protocol was incorporated into the OTCIXS II protocol.

b. Crypto Synchronization Factors

C dnlf uplf dnlf uplf dnlf uplf

Where:

dnlf – Real number specifying the down link performance.

uplf – Real number specifying the up link performance.

c. DAMA Mode

D berlb berub berlb berup berlb berub

Where:

berlb – Bit error rate lower bound.

berup – Bit error rate upper bound.

d. Event History File

E filespec

Where:

filespec – file specification (30 characters or less) in the form
device:[directory]filename.extersnion;revision . The device and directory default to the
current user area. The cycle defaults to the most recent.

e. DAMA Figure Of Merit

F fomlb fomub fomlb fomub fomlb fomub

Where:

fomlb – figure of merit lower bound. The value should be a real number between 0
and 1. The three pairs of numbers are used for the three different type class of subscriber
transmit signal quality.

fomup – figure of merit upper bound.

f. Network Description File

I filespec

Where:

filespec- file specification (30 characters of less) in the form
device:[directory]filename.execution;revision. The device and directory default to the
current user area. The cycle defaults to the most recent. This file name must be the output
file from the OTCEDT program.

g. Traffic Multiplier

M number

Where:

number- Real number used to change the subscriber transmission rates. Default is 1.

h. Simulation Title

N title

Where:

Title – 1 to 60 ASCII characters

i. Signal/Noise Specification

P snr per

Where:

snr – Signal noise ration; this value should be between the low signal noise and high signal noise values, inclusive, used in the NDF model definition (NOISE = BURST (initiation time, average duration, low signal noise, high signal noise)).

per – Signal error rate probability; the grater this value, the greater the probability of noise burst errors occuring.

j. Link Environmental Parameters

Q	ADRSIZ	integer
	ADVUSR	integer
	BLKSIZ	integer
	CHKSUM	integer
	CRYPTO	{84}
	GDTSIZ	real
	HPRRS	integer
	LBPS	real
	LRATE	real
	MAXADR	integer
	MAXCPY	integer
	MSGCHK	integer
	MSGHDR	integer
	MSGHP	integer
	NCSID	sid
	PTRBYT	integer
	PTRCHK	integer
	RCVMDO	{T,F}

RRSGDT	real
RESCHD	
TOTRRS	integer
TTYMAX	integer

Where:

ADRSIZ – Length in bytes per datalink message address. Range of values: 1 to 4.

Default : 2.

ADVUSR- Specifies frequent users polling list. The numbers must correspond to the subscriber identification numbers used in the NDF definitions. The subscribers in the polling list are automatically acknowledged/pollled for low priority data transmissions.

Range of values: 1 to number of subscribers. Default : None

BLKSIZ – Number of bytes per data block. Range of values: 64 to 1024. Default : 256.

CHKSUM – Number of bytes per each data block's checksum. Range of values: 0 to 4. Default : 2.

CRYPTO – Crypto device type of KG-84. Range of value: 84. Default : 84

GDTSIZ - Guard time in seconds. Range of values: 0.0 to 1.0. Default : 0.25.

HPRRS – Specifies the number of high priority reservation request slots. Range of values: 1 to 20. Default : 1.

LBPC – Number bits/character transferred. Range of values: 6.0 to 10.5. Default : 8.0

LRATE – Subscriber satellite transfer rate in bits/second. Range of values: 75.0 to 19200.0. Default : 2400.0.

MAXADDR – Maximum number of addresses per message. Ignored by simulator. Range of values: 0 to 8. Default : 5.

MAXCPY – Number of times a subscriber uplinks transmission units (TU) will be transmitted in a SATS or BUSY cycle. A value of zero activates dynamic computation of the number of transmits based on the subscriber class type defined in the NDF (type 1 is best quality transmission and type 3 is poorest quality). Range of values: 0 to 5. Default: 2.

MSGCHK – Length in bytes of datalink message checksum. Range of values: 0 to 4. Default : 2.

MSGHDR – Length of datalink message header. Ignored by simulator. Range of values: 0 to 16. Default : 0 (included in data length).

MSGPH – Number of messages per hour to be generated in the network by all subscribers. Range of values: 10 to 1000. Default: 140.

NCSID – Net control station identifier. Must be one of the subscribers identifiers assigned in the NDF. Range of values: 1 to total number of subscribers. Assumes subscribers are assigned sequential numbers starting with 1. Default : 1.

PTRBYT – Number of bytes per datalink TU message pointer. Range of values: 0 to 4. Default: 2.

PTRCHK – Number of bytes per datalink TU pointer block checksum. Range of values: 0 to 4. Default: 2.

RCVMOD – Message processing takes place after every copy (TRUE) or after last copy (FALSE). Range of values: TRUE, FALSE. Default: FALSE.

RESCHD – Enables automatic “piggy-backing” of link access during transmission unit processing. The default state is no piggy-backed rescheduling; this option turns it on. Range of values: None. Default: False condition.

RRSGDT – Reservation request slot guard time. Valid for non-DAMA link

operations. Range of values: 0.0 to 1.3. Default: 0.5.

TOTRRS – Total number of reservation request slots. Range of values: 3 to 20.
Default: 8.

TTYMAX – Maximum length of TTY messages, in bytes. Range of values: 1024 to 8192. Default: 8000.

Note: These parameters persist from one exercise to the next and need only be entered when they change from the default or the last entered value.

k. Random Number Seed

R integer integer integer integer

Where:

integer – Number used as initial value for random number generation.

l. Scenario Exercise Specification

S scenario exercise

Where:

scenario – Integer identifying the scenario

exercise – Integer identifying the exercise in the current scenario

m. Termination Criteria

T ttymsg datamsg maxtime

Where:

ttymsg – Integer indicating maximum number of TTY messages to be sent.

Default: 10.

datamsg – Integer indicating maximum number of datalink messages to be sent.

Default: 50.

maxtime – Real number indicating maximum simulation time. Not clock time or computer time, but simulated clock time. Time interval is entered in seconds. Default: 1200.0

n. Summary File

X filespec

Where:

filespec – file specification (30 characters or less) in the form.

device:[directory]filename.extension;revision. The device and directory default to the current user area. The cycle defaults to the most recent.

THIS PAGE INTENTIONALLY LEFT BLANK

APPENDIX E

SETUP FILE STANDARD VALUES

A. NON-DAMA PARAMETERS

N OTCIXS II
A
I MODEL1.NDF
R 127 73 149 29
C 0.9787 0.9787 0.9587 0.9587 0.9344 0.9344
F 0.7 1.0 0.5 0.8 0.3 0.6
P 8.00 0.0000145
P 8.45 0.000015
P 8.90 0.0000155
P 9.35 0.000016
P 9.80 0.0000165
P 10.25 0.000017
P 10.70 0.0000175
P 11.15 0.000018
P 11.60 0.0000185
P 12.00 0.000019
Q LBPC 8.0
Q LRATE 2400.0
Q NCSID 4
T 100 1000 18000

B. DAMA PARAMETERS

N OTCIXS II
A
D 0.000015 0.00002 0.000005 0.00001 0.0000015 0.000004
I MODEL1.NDF
R 127 73 149 29
C 0.9787 0.9787 0.9587 0.9587 0.9344 0.9344
F 0.7 1.0 0.5 0.8 0.3 0.6
P 8.00 0.0000145
P 8.45 0.000015
P 8.90 0.0000155
P 9.35 0.000016
P 9.80 0.0000165
P 10.25 0.000017
P 10.70 0.0000175
P 11.15 0.000018
P 11.60 0.0000185

P	12.00	0.000019
Q	LBPC	8.0
Q	LRATE	2400.0
Q	NCSID	4
T	100 1000 18000	

LIST OF REFERENCES

PROGRAM DEFINITION DOCUMENTS.

a. FSCS-214-01A, Type A System Specification for the Officer in Tactical Command Information Exchange Subsystem II (OTCIXS II), SPAWARSYSCOM, 15 July 1988 with change 1.

b. FSCS-205-01B, Type A System Specification for the Tactical Data Information Exchange Subsystem (TADIXS) Phase IV, Revision B, SPAWARSYSCOM, 6 May 1988 with changes 1 and 2.

c. FSCS-205-20-1A, Program Performance Specification for the Tactical Data Information Exchange Subsystem (TADIXS) Gateway Processor (TGP), Phase IV, Revision A (Draft), SPAWARSYSCOM, 10 February 1988.

d. FSCS-205-20-3A, Program Performance Specification for the Tactical Data Information Exchange Subsystem (TADIXS) Radio Controller (RADCON) Phase IV, AN/USQ-64(V)x, SPAWARSYSCOM, 1 September 1987.

e. TE660-AD-MMO-020/PPS8430, Program Performance Specification for the Tactical Data Information Exchange Subsystem (TADIXS)/Officer-in-Tactical Command Information Exchange Subsystem Phase III, Revision 1, FCDSSA, 30 June 1987.

f. /IDS8648, Interface Design Specification between Officer-in-Tactical Command Information Exchange Subsystem (OTCIXS)/ Tactical Data Information Exchange Subsystem (TADIXS) and Tactical Data Processor (TDP) Systems, Revision 3, FCDSSA, 15 June 1987.

g. /IDS8649, Interface Design Specification between Officer in Tactical

Command Information Exchange Subsystem (OTCIXS)/ Tactical Data Information Exchange Subsystem (TADIXS) and the Sensor Interface Unit (SIU), Revision 1, FCDSSA, 27 September 1985 with change 1 (30 September 1986).

h. FSCS-205-24A, Interface Design Specification for the Tactical Data Information Exchange Subsystem (TADIXS), Phase IV, Volume I, Introduction, Revision A (Preliminary), SPAWARSSYSCOM, 29 January 1993.

i. FSCS-205-24A, Interface Design Specification for the Tactical Data Information Exchange Subsystem (TADIXS), Phase IV, Volume II, TADIXS Gateway Processor to Radio Controller, Revision A (Draft), SPAWARSSYSCOM, 11 March 1988.

j. PDW-120-S-00509, Over-the-Horizon Detection, Classification and Targeting (OTH/DCT) System Level Specification - Communications, Revision B, SPAWARSSYSCOM, 13 June 1985.

MILITARY SPECIFICATIONS.

a. MIL-STD-188C Military Communication System Technical Standard, DoD, 24 November 1969.

b. DOD-STD-1679A, Military Standard Software Development, DoD, 22 October 1983.

OTHER PUBLICATIONS.

a. ANSI X3.66, American National Standard for Advanced Data Communications Control Procedure (ADCCP), 1979.

b. International Telegraph and Telephone Consultative Committee (CCITT)

Recommendation V.41, 1980.

c. EE130-AC-OMI-010/E106, ON-143(V)X - Technical Manual - Operation and Maintenance Instructions - Organizational Level - Interconnecting Group ON-143(V)X/USQ, 30 June 1982.

d. EE163-GA-OMI-010/E106-TD1271B - Technical Manual - Operation and Maintenance Instructions - Organizational Level - Multiplexer TD-1271B/U.

THIS PAGE INTENTIONALLY LEFT BLANK

INITIAL DISTRIBUTION LIST

1. Defense Technical Information Center2
8725 John J. Kingman Rd., STE 0944
Ft. Belvoir, Virginia 22060-6218

2. Dudley Knox Library2
Naval Postgraduate School
411 Dyer Road
Monterey, California 93943-5101

3. Chairman, Code CS1
Naval Postgraduate School
Monterey, California 93943-5100

4. Professor Bert Lundy CS/LN1
Computer Science Department
Naval Postgraduate School
833 Dyer Road
Monterey, California 93943-5100

5. Commanding Officer1
ATTN John K. O'Leary / D8705
SPAWAR SYSTEMS CENTER San Diego
53560 Hull Street
San Diego, California 92152-5001

6. Commanding Officer2
ATTN Robert L. Franco / D873
SPAWAR SYSTEMS CENTER San Diego
53560 Hull Street
San Diego, California 92152-5001