

9/14/59  
NACA TN 2092

# NATIONAL ADVISORY COMMITTEE FOR AERONAUTICS

TECHNICAL NOTE 2092

APPROXIMATE AERODYNAMIC INFLUENCE COEFFICIENTS FOR  
WINGS OF ARBITRARY PLAN FORM IN SUBSONIC FLOW

By Franklin W. Diederich

Langley Aeronautical Laboratory  
Langley Air Force Base, Va.



**Reproduced From  
Best Available Copy**

Washington  
July 1950

**DISTRIBUTION STATEMENT A**  
Approved for Public Release  
Distribution Unlimited

20000731 192

DTIC QUALITY INSPECTED 4

AQM00-10-3366

NATIONAL ADVISORY COMMITTEE FOR AERONAUTICS

TECHNICAL NOTE 2092

APPROXIMATE AERODYNAMIC INFLUENCE COEFFICIENTS FOR  
WINGS OF ARBITRARY PLAN FORM IN SUBSONIC FLOW

By Franklin W. Diederich

SUMMARY

Aerodynamic influence coefficients for symmetrically loaded wings of arbitrary plan form in subsonic flow are derived from a simple empirical method of estimating spanwise lift distributions. The application of the coefficients to an aeroelastic analysis is discussed.

INTRODUCTION

In the aeroelastic analysis of reference 1 the spanwise lift distribution was assumed to be given by strip theory with over-all reduction and rounding at the tip to take aerodynamic induction approximately into account. The spanwise lift distribution may be incorporated into the aeroelastic analysis more accurately by using suitable aerodynamic influence coefficients. In this paper a method is presented for determining approximate aerodynamic influence coefficients for symmetric loadings from the method of estimating lift distributions presented in reference 2. An approximate means of taking the effect of the fuselage into account is also presented in the present paper; it is based on the assumption that the fuselage carries an amount of lift which depends solely on the angle of attack of the wing at its root.

Although this paper is intended primarily as an adjunct to reference 1, the method and coefficients presented herein may be used for calculating lift distributions apart from reference 1. In order to facilitate the application of the present paper to such calculations, all required definitions and numerical factors are presented herein. As in reference 1 matrix notation is used in the present paper. A short summary of matrix notation and algebra and a discussion and derivation of the pertinent integrating matrices are given in reference 1.

## SYMBOLS

b	span
b'	span less fuselage width
c	chord, parallel to plane of symmetry
$\bar{c}$	average chord $\left(\frac{S}{b}\right)$
$c_e$	average of root chord and chord in plane of symmetry
$c_s$	chord in plane of symmetry
$c_l$	local lift coefficient
$C_{L\alpha}$	wing lift-curve slope
w	fuselage width
f	"ideal" function (see fig. 1)
g	factor defined by equation (11)
$[K_1], [\bar{K}_1], [\bar{K}_{1e}]$	integrating matrices
$[K_1]_1$	first row of $K_1$ matrix
$[Q]$	aerodynamic-influence-coefficient matrix
S	total wing area
y	lateral ordinate measured from plane of symmetry
$y^*$	dimensionless lateral ordinate $\left(\frac{y}{b/2}\right)$
$\alpha$	angle of attack
$\bar{\alpha}$	average angle of attack, defined by equation (2)
$\eta$	lateral ordinate measured from wing root
$\eta^*$	dimensionless lateral ordinate $\left(\frac{\eta}{b'/2}\right)$

$\lambda$  taper ratio  
 $\Lambda$  angle of sweepback at quarter-chord line

## Subscripts:

a additional  
 b basic  
 r root

## Matrix notation:

$[ ]$  square matrix  
 $[ \overset{\circ}{ } ]$  diagonal matrix  
 $\{ \}$  column matrix  
 $[ \ ]$  row matrix  
 $[ I ]$  unit matrix

## CALCULATION OF INFLUENCE COEFFICIENTS

## Wing Alone

In reference 2 the spanwise lift distribution at subsonic speeds for any angle-of-attack distribution is obtained by considering separately the additional lift distribution and the basic lift distribution. The additional lift distribution is calculated from the average of the chord distribution and an "ideal" function  $f$  (given in reference 2 and reproduced in fig. 1 of the present paper), which has been obtained empirically for various angles of sweep:

$$\left( \frac{cc_l}{c} \right)_a = C_{L\alpha} \frac{1}{2} \left( \frac{c}{\bar{c}} + f \right) \bar{\alpha} \quad (1)$$

The average angle of attack  $\bar{\alpha}$  is obtained from

$$\bar{\alpha} = \frac{2}{S} \int_0^{b/2} \alpha c \, dy = \int_0^1 \alpha \frac{c}{\bar{c}} \, dy^* \quad (2)$$

where  $y^*$  is the dimensionless lateral ordinate defined by

$$y^* = \frac{y}{b/2}$$

Similarly, the basic lift distribution is obtained from one-half of the product of the chord distribution and the angle-of-attack distribution for zero lift ( $\alpha - \bar{\alpha}$ ):

$$\left(\frac{cc_l}{\bar{c}}\right)_b = C_{L\alpha} \frac{1}{2} \frac{c}{\bar{c}} (\alpha - \bar{\alpha}) \quad (3)$$

Any sharp corners in the resulting distribution must be rounded off.

Equations (1) and (3) may be combined and written in matrix notation as

$$\left\{ \frac{cc_l}{\bar{c}} \right\} = C_{L\alpha} \left\{ \frac{1}{2} \bar{\alpha} \overset{\circ}{[f]} \{1\} + \frac{1}{2} \overset{\circ}{\left[ \frac{c}{\bar{c}} \right]} \{ \alpha \} \right\} \quad (4)$$

where  $\{1\}$  represents a column of 1's. The integral required in calculating  $\bar{\alpha}$  may be evaluated by means of an integrating matrix. The first row of the  $K_1$  matrix of reference 1  $[K_1]_1$  serves to perform this operation and round off the basic distribution at the same time. The six-point  $[K_1]_1$  matrix (shown in table 1 of the present paper) is based on spanwise stations located at 0, 0.2, 0.4, 0.6, 0.8, and 0.9 of the distance over which the integration is performed. Consequently, the analysis of the wing alone is based on stations corresponding to  $y^* = 0, 0.2, 0.4, 0.6, 0.8, \text{ and } 0.9$ .

In order to fulfill the requirement that the integral of the basic lift distribution is zero, the value of  $\bar{\alpha}$  may be determined from the relation

$$[K_1]_1 C_{L\alpha} \frac{1}{2} \overset{\circ}{\left[ \frac{c}{\bar{c}} \right]} \left\{ \alpha - \bar{\alpha} \right\} = 0$$

or

$$\bar{\alpha} = g \left[ K_1 \right]_1 \left[ \frac{c}{\bar{c}} \right] \left\{ \alpha \right\} \quad (5)$$

where, for the special case of the wing alone,

$$g = \frac{1}{\left[ K_1 \right]_1 \left[ \frac{c}{\bar{c}} \right] \left\{ 1 \right\}} \quad (6)$$

The value of  $g$  is presented for various values of the taper ratio in figure 2. The case of the wing alone corresponds to  $\frac{w}{b} = 0$ .

Equation (5) may be substituted in equation (4) and both sides multiplied by  $\frac{\bar{c}}{c_r}$  to yield

$$\left\{ \frac{cc_l}{c_r} \right\} = C_{L\alpha} \left[ Q \right] \left\{ \alpha \right\} \quad (7)$$

where the aerodynamic-influence-coefficient matrix  $Q$  is defined by

$$\left[ Q \right] = \left[ g \left[ f \right] \frac{1}{2} \left[ \bar{K}_1 \right] + \frac{1}{2} \left[ I \right] \right] \left[ \frac{c}{c_r} \right] \quad (8)$$

The  $\bar{K}_1$  matrix is a square matrix consisting of rows all equal to  $\left[ K_1 \right]_1$ .

The elements of  $\frac{1}{2} \left[ \bar{K}_1 \right]$  and  $\frac{1}{2} \left[ I \right]$  are given in table 1, the factor of  $\frac{1}{2}$  being included to avoid the necessity of a final multiplication by that factor. In equations (7) and (8) the chord at the plane of symmetry could be used instead of the root chord  $c_r$  since the two are identical for a wing without fuselage.

In calculating the  $Q$  matrix the  $f$  values are first read for the given sweep angle from figure 1 at  $y^*$  values of 0, 0.2, 0.4, 0.6, 0.8, and 0.9; these  $f$  values are then entered in a diagonal matrix as shown in table 2 for an example wing with  $30^\circ$  sweepback. A value of  $g$  is then read from figure 2 for the given taper ratio ( $\lambda = 0.5$  for the example wing) and multiplied into the  $f$  matrix. The resulting matrix is postmultiplied by the  $\frac{1}{2} \left[ \bar{K}_1 \right]$  matrix of table 1. (See table 2 for

the result of this operation in the case of the example wing.) The  $\frac{1}{2}[\mathbf{I}]$  matrix is then added to the product. The resulting matrix is postmultiplied by a diagonal matrix of the  $\frac{c}{c_r}$  values at the previously cited values of  $y^*$  in order to obtain the desired  $Q$  matrix. (See table 2.)

### Wing and Fuselage

For the purpose of calculating aeroelastic effects the presence of the fuselage may be taken into account in several ways. In one method the wing root is considered to be at the plane of symmetry and the part of the wing inside the fuselage, to be infinitely stiff. In this case the coefficients obtained in the foregoing section may be used.

Another method consists of calculating the aerodynamic influence coefficients for stations corresponding to  $\eta^*$  (rather than  $y^*$ ) values of 0, 0.2, 0.4, 0.6, 0.8, and 0.9. In that case an assumption has to be made concerning the amount of lift carried by the fuselage and the effect of this lift on that carried by the wing.

For untwisted wings it is commonly assumed that the fuselage carries the same lift as the part of the wing it intercepts. In this analysis the same assumption is made for a twisted wing, and the part of the wing intercepted by the fuselage is assumed to be at the angle of attack of the wing root. The value of  $\bar{\alpha}$  for this assumption may then be obtained from the requirement that the basic lift distribution integrates to zero:

$$\frac{C_{L\alpha}}{2}(\alpha_r - \bar{\alpha})\frac{w}{b}\frac{1}{2}\left(\frac{c_s}{c} + \frac{c_r}{c}\right) + \frac{b'}{b}[K_1]_1 \frac{C_{L\alpha}}{2}\left[\frac{c}{c}\right]^0 \left\{\alpha - \bar{\alpha}\right\} = 0$$

or

$$\bar{\alpha} = g\left(\left(\frac{w}{b'}\frac{c_e}{c_r}\right)\left(\frac{c_r}{c}\alpha_r\right) + [K_1]_1\left[\frac{c}{c}\right]^0\left\{\alpha\right\}\right) \quad (9)$$

where  $w$ ,  $b'$ ,  $c_s$ , and  $c_r$  are geometric parameters defined in figure 3,

$$c_e = \frac{c_s + c_r}{2} \quad (10)$$

and

$$g = \frac{1}{\frac{w}{b'} \frac{c_e}{c} + \left[ \bar{K}_1 \right]_1 \left[ \frac{c}{c} \right] \{1\}} \quad (11)$$

Values of  $g$  are presented in figure 2 as a function of the fuselage-width and taper ratios.

With the value of  $\bar{\alpha}$  given by equation (9), equation (4) takes the form of equation (7) where  $Q$  is now defined by

$$\left[ Q \right] = \left[ g \left[ f \right] \frac{1}{2} \left[ \bar{K}_1 \right]_e \right] + \frac{1}{2} \left[ I \right] \left[ \frac{c}{c_r} \right] \quad (12)$$

Comparison of equations (9) and (12) with equations (5) and (8), respectively, indicates that the  $\left[ \bar{K}_1 \right]_e$  matrix is obtained by adding the quantity  $\frac{w}{b'} \frac{c_e}{c_r}$  to every element of the first column of the  $\left[ \bar{K}_1 \right]$  matrix.

When the  $Q$  matrix of equation (12) is used in equation (7), the values of  $\frac{c c_l}{c_r}$  will be obtained at stations corresponding to  $\eta^* = 0, 0.2, 0.4, 0.6, 0.8,$  and  $0.9$  for the given values of the angle of attack at those stations. The relation

$$y^* = \frac{b'}{b} \eta^* + \frac{w}{b}$$

may facilitate determination of the stations of interest. In calculating the  $Q$  matrix for the wing-fuselage combination, values of the  $f$  function and the  $\frac{c}{c_r}$  ratio are obtained at those stations. The average chord  $c_e$ , which is calculated from equation (9), is used to obtain the term  $\frac{1}{2} \frac{w}{b'} \frac{c_e}{c_r}$ , which is added to each element of the first column of the  $\frac{1}{2} \left[ \bar{K}_1 \right]$  matrix of table 1 to yield the  $\frac{1}{2} \left[ \bar{K}_1 \right]_e$  matrix.

This matrix is premultiplied by a diagonal matrix obtained by multiplying the  $f$  matrix by the value of  $g$  taken from figure 2 for

the given configuration. The  $\frac{1}{2}[I]$  matrix is added to the resulting matrix and the result is postmultiplied by the  $\frac{c}{c_r}$  matrix to yield the desired  $Q$  matrix.

#### APPLICATION OF INFLUENCE COEFFICIENTS

The aerodynamic influence coefficients calculated as outlined in the foregoing section may be used to calculate the lift distribution of wings with arbitrary sweep and taper for any symmetrical angle-of-attack distribution. (For discontinuous distributions, such as those caused by flap deflections, the equivalent  $\delta$  values of reference 3 may be used in order to obtain the rounding of the lift distribution at the point of discontinuity called for in reference 2.) Once the coefficients have been calculated for the plan form of interest (with or without fuselage), the values of the loading coefficient  $\frac{cc_l}{c_r}$  at stations corresponding to 0, 0.2, 0.4, 0.6, 0.8, and 0.9 of the distance from the wing root to the wing tip are obtained by premultiplying a column matrix of the values of the angle of attack at those stations by the influence-coefficient matrix.

When the influence coefficients are used in conjunction with the method of aeroelastic analysis presented in reference 1, steps (6) and (11) in table VI of reference 1 must be modified. The influence-coefficient matrix replaces the  $\frac{c}{c_r}$  matrix used in step (11). A matrix

$\left[ \begin{array}{c} e_{10} \\ e_{1r} \end{array} \frac{c}{c_r} \right]_{\text{sub}}$  must be calculated (from the given values of the moment

arm  $e_1$  pertinent to subsonic speeds and the given chord ratio  $\frac{c}{c_r}$ ) and postmultiplied by the influence-coefficient matrix. The resulting

matrix replaces the  $\left[ \begin{array}{c} e_{10} \\ e_{1r} \end{array} \left( \frac{c}{c_r} \right)^2 \right]_{\text{sub}}$  matrix called for in step (6). This

procedure is not applicable to the supersonic case since the aerodynamic influence coefficients have been obtained only for the subsonic case. Elsewhere in the method of reference 1, the lift-curve slope  $Cl_{\alpha}$  of the present paper is used in place of the effective slopes  $m_e$  and  $m_{e1}$ , the ratio  $\frac{m_{e1}}{m_e}$  is taken as 1, and the equivalent angle of attack  $\bar{\alpha}$  of reference 1 (not to be confused with the average angle of attack  $\bar{\alpha}$  of the present paper) is merely the sum of the geometric and structural

angles of attack. A convenient way of obtaining the lift coefficient for any calculated loading consists of multiplying the  $\bar{a}$  values obtained from equation (5) or (9) by the lift-curve slope  $Cl_{\alpha}$ . In all other respects the calculations indicated in reference 1 are unaffected by the use of the influence coefficients.

Compressibility corrections may be applied, as suggested in reference 2, by using an  $f$  function corresponding to an effective sweep angle and by using a corrected lift-curve slope.

### DISCUSSION

The influence-coefficient matrices of this paper constitute an expression of the empirical method of reference 2 in matrix form. The matrix elements are influence coefficients in the generalized sense that if multiplied by the angle-of-attack values along the span and summed up they will yield the value of the lift at a given station. Individually the elements do not necessarily represent the value of the lift at a given station due to a unit angle of attack at another station in the more narrow meaning of the term "influence coefficient."

The discussion in reference 2 of the merits and demerits of the empirical method applies to the aerodynamic influence coefficients as well. In short, at subcritical speeds they may be expected to yield results which are more reliable than those of a strip-theory analysis but not so reliable on the average as the results of one of the more refined theories for spanwise load distribution. The results differ from those of the method of reference 2 in only one respect. The rounding of the basic loading curve required in reference 2 is performed by integrating matrices in the present paper. In order to show the effect of this difference, the results of the two approaches for the basic lift distribution of an untapered unswept wing with washout of 1 radian are shown in figure 4. Also shown are results calculated by means of Multhopp's and Weissinger's analytical methods and on the basis of the modified strip theory used in reference 1.

The influence-coefficient method and the method of reference 2 yield almost identical results, which are in fair agreement with the results of Multhopp's and Weissinger's analytical methods. The agreement of the results calculated by the modified strip theory of reference 1 with the analytical results is somewhat poorer on the average. (The results of unmodified strip theory would be much poorer; for the case of fig. 4 the loading-coefficient curve would be 80 percent larger at every point than that of the modified strip theory and would not be rounded off at the tip.)

The methods used for the calculations represented in figure 4 (except that of modified strip theory) would yield almost equal results for the additional loading, which would be intermediate between elliptical and rectangular; whereas the result of modified strip theory would be a rectangular distribution rounded only at the tip. The results of the influence-coefficient method are therefore superior to those of the modified strip theory for both basic and additional lift distributions, although the difference is not so large for tapered wings as for the untapered wing considered in figure 4. Since the agreement of the results of the influence-coefficient method with those of the analytical methods is somewhat poorer for basic lift distributions than for additional lift distributions, the influence coefficients may be expected to be most useful when the angle of twist is less than the angle of attack. The influence coefficients will probably furnish fairly reliable results for the change in loading due to aeroelastic effects but somewhat less reliable results for the divergence speed. In general, they tend to overestimate the lift, particularly at the wing tip, so that aeroelastic effects are overestimated to some extent. For similar reasons the influence coefficients of this paper are not applicable to antisymmetric lift distributions because these lift distributions do not have an additional part.

#### CONCLUDING REMARKS

A method has been presented for calculating aerodynamic influence coefficients for symmetrical loadings at subsonic speeds from a simple empirical method of estimating spanwise lift distributions. The coefficients are particularly suited for aeroelastic analyses and may be expected to give good results for the changes in spanwise loading associated with aeroelastic effects but probably less reliable results for the divergence speed.

Langley Aeronautical Laboratory  
National Advisory Committee for Aeronautics  
Langley Air Force Base, Va., March 3, 1950

## REFERENCES

1. Diederich, Franklin W.: Calculation of the Aerodynamic Loading of Flexible Wings of Arbitrary Plan Form and Stiffness. NACA TN 1876, 1949.
2. Diederich, Franklin W.: A Simple Approximate Method for Obtaining Spanwise Lift Distribution over Swept Wings. NACA RM L7107, 1948.
3. Diederich, Franklin W.: Calculation of the Effects of Structural Flexibility on Lateral Control of Wings of Arbitrary Plan Form and Stiffness. NACA RM L8H24a, 1948.

TABLE 1

VALUES OF THE  $[K_1]_1$ ,  $\frac{1}{2}[\bar{K}_1]$ , AND  $\frac{1}{2}[I]$  MATRICES
$$[K_1]_1$$

Root			Tip		
0.06667	0.26667	0.13333	0.26667	0.09333	0.15085

$$\frac{1}{2}[\bar{K}_1]$$

Root			Tip		
0.03333	0.13333	0.06667	0.13333	0.04667	0.07542
.03333	.13333	.06667	.13333	.04667	.07542
.03333	.13333	.06667	.13333	.04667	.07542
.03333	.13333	.06667	.13333	.04667	.07542
.03333	.13333	.06667	.13333	.04667	.07542
.03333	.13333	.06667	.13333	.04667	.07542

Tip

$$\frac{1}{2}[I]$$

0.5000	0	0	0	0	0
0	.5000	0	0	0	0
0	0	.5000	0	0	0
0	0	0	.5000	0	0
0	0	0	0	.5000	0
0	0	0	0	0	.5000

TABLE 2  
SOME STEPS IN THE CALCULATION OF THE AERODYNAMIC-INFLUENCE-COEFFICIENT MATRIX FOR A  
WING WITH 30° SWEEPBACK, 0.5 TAPER RATIO

$\begin{bmatrix} f \\ f \end{bmatrix}$		$\begin{bmatrix} c \\ c_T \end{bmatrix}$	
Root	Tip	Root	Tip
1.037	0	1.0000	0
0	1.164	0	.9000
0	0	0	.8000
0	0	0	.7000
0	0	0	.6000
0	0	0	.5500

$* g \begin{bmatrix} f \\ f \end{bmatrix} \frac{1}{2} \begin{bmatrix} K_1 \\ K_1 \end{bmatrix}$		$[q]$	
Root	Tip	Root	Tip
0.0351	0.1403	0.5351	0.1263
.0394	.1575	.0394	.5918
.0411	.1646	.0411	.1481
.0387	.1548	.0387	.1393
.0299	.1195	.0299	.1075
.0197	.0789	.0197	.0710
0.0702	0.1403	0.0561	0.0982
.0788	.1575	.0630	.1103
.0823	.1646	.4658	.1152
.0774	.1548	.0619	.4584
.0598	.1195	.0478	.0836
.0395	.0789	.0316	.0552
0.0491	0.0794	0.0295	0.0437
.0551	.0891	.0331	.0490
.0576	.0931	.0346	.0512
.0542	.0876	.0325	.0482
.0418	.0676	.3251	.0372
.0276	.0446	.0166	.2996

\* g = 1.0149



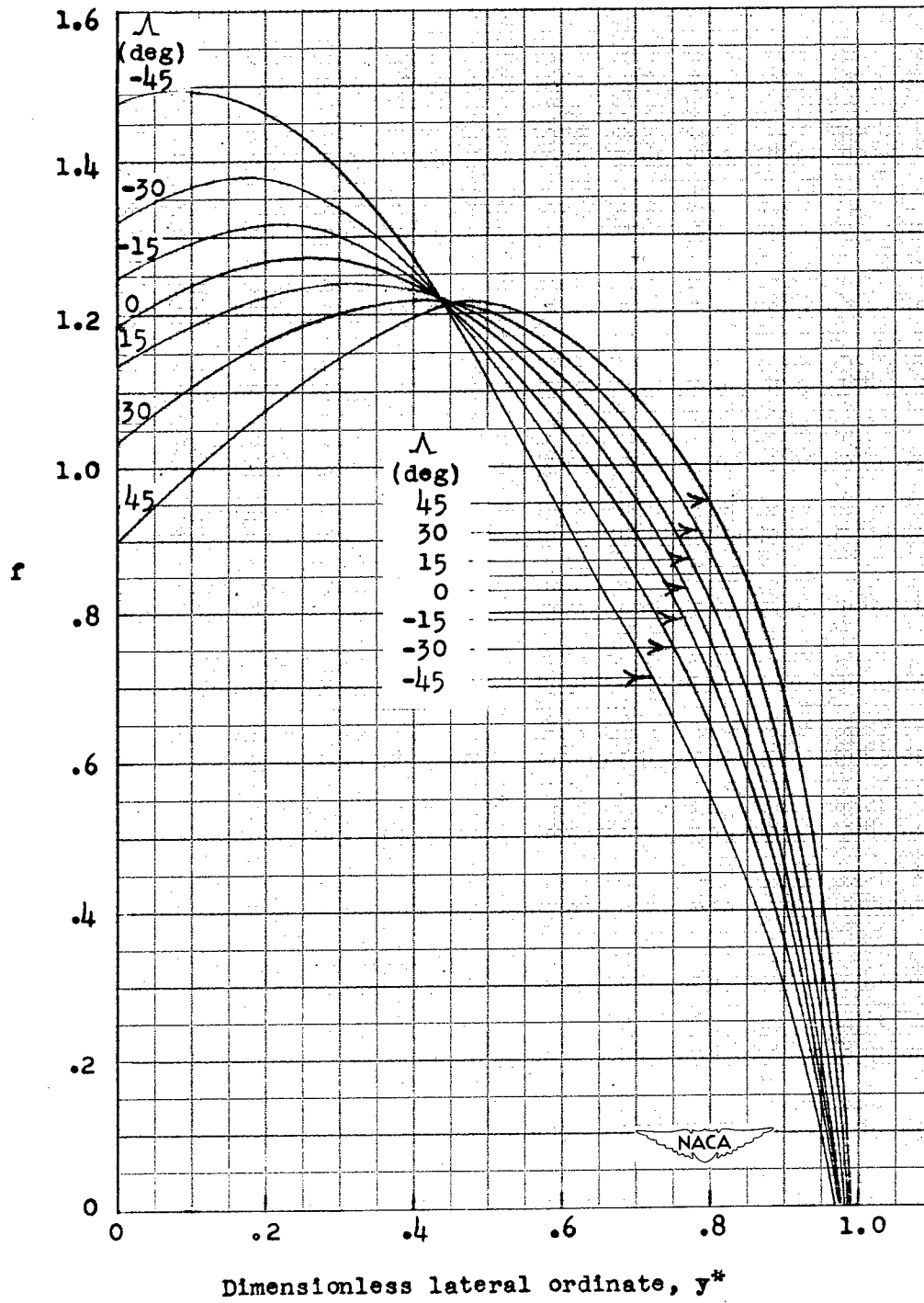

Figure 1.- The "ideal" distribution  $f$ .

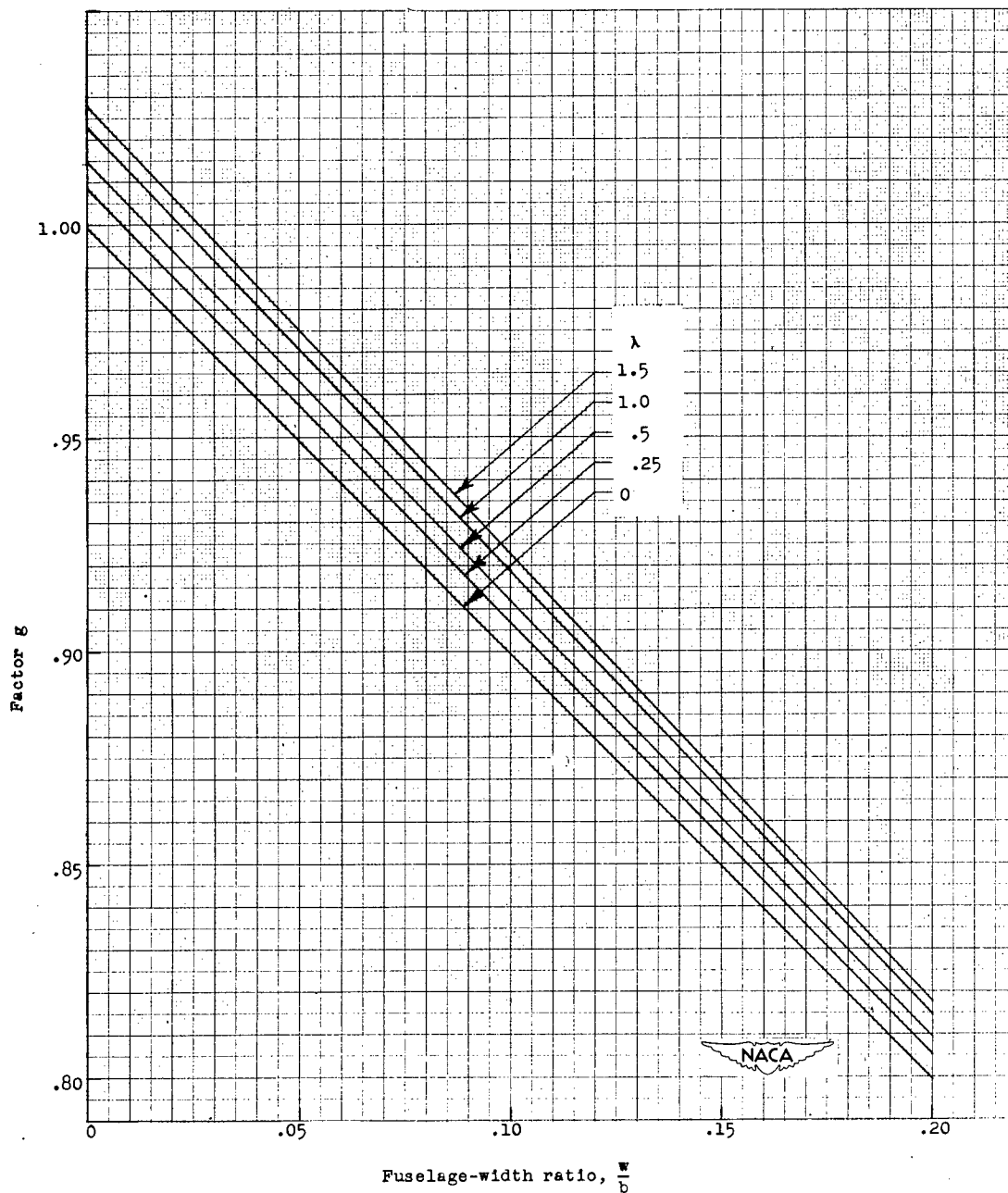

Figure 2.- Values of the factor g.

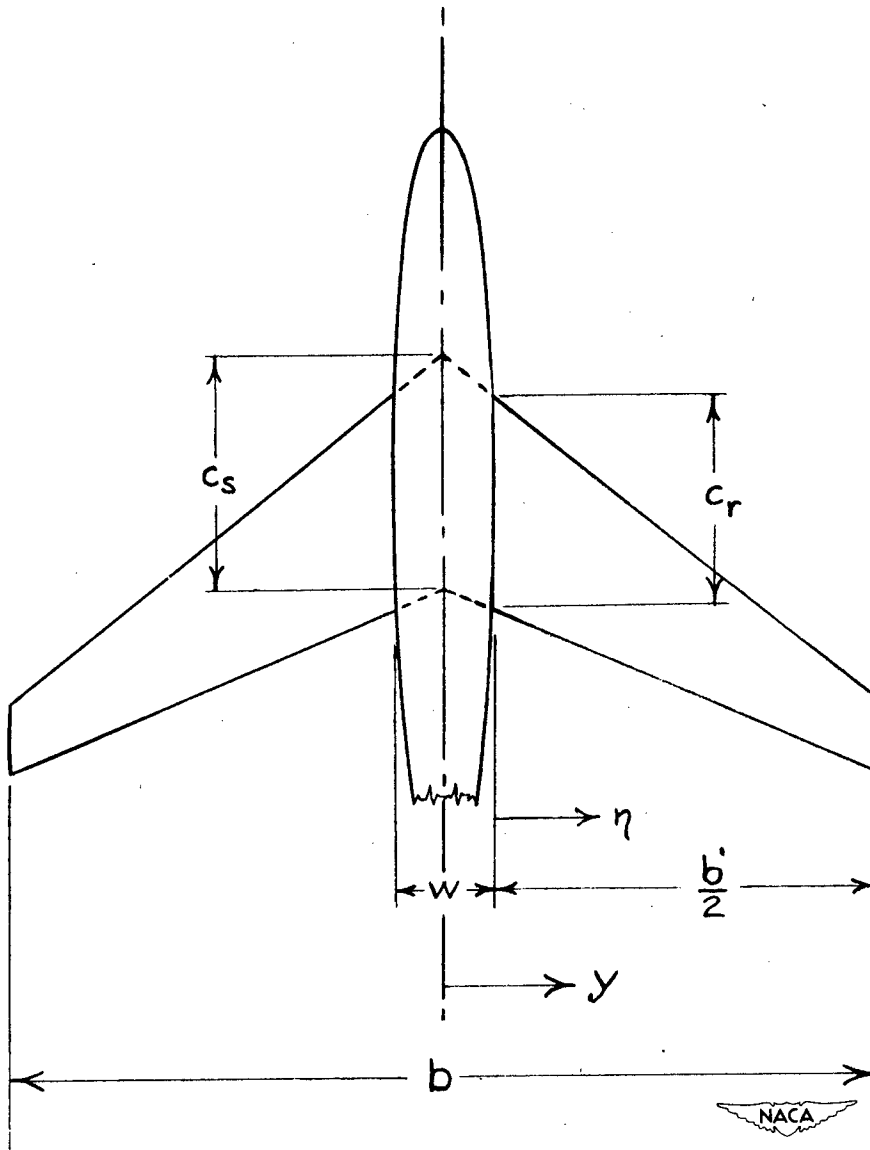

Figure 3.- Definitions of geometric parameters.

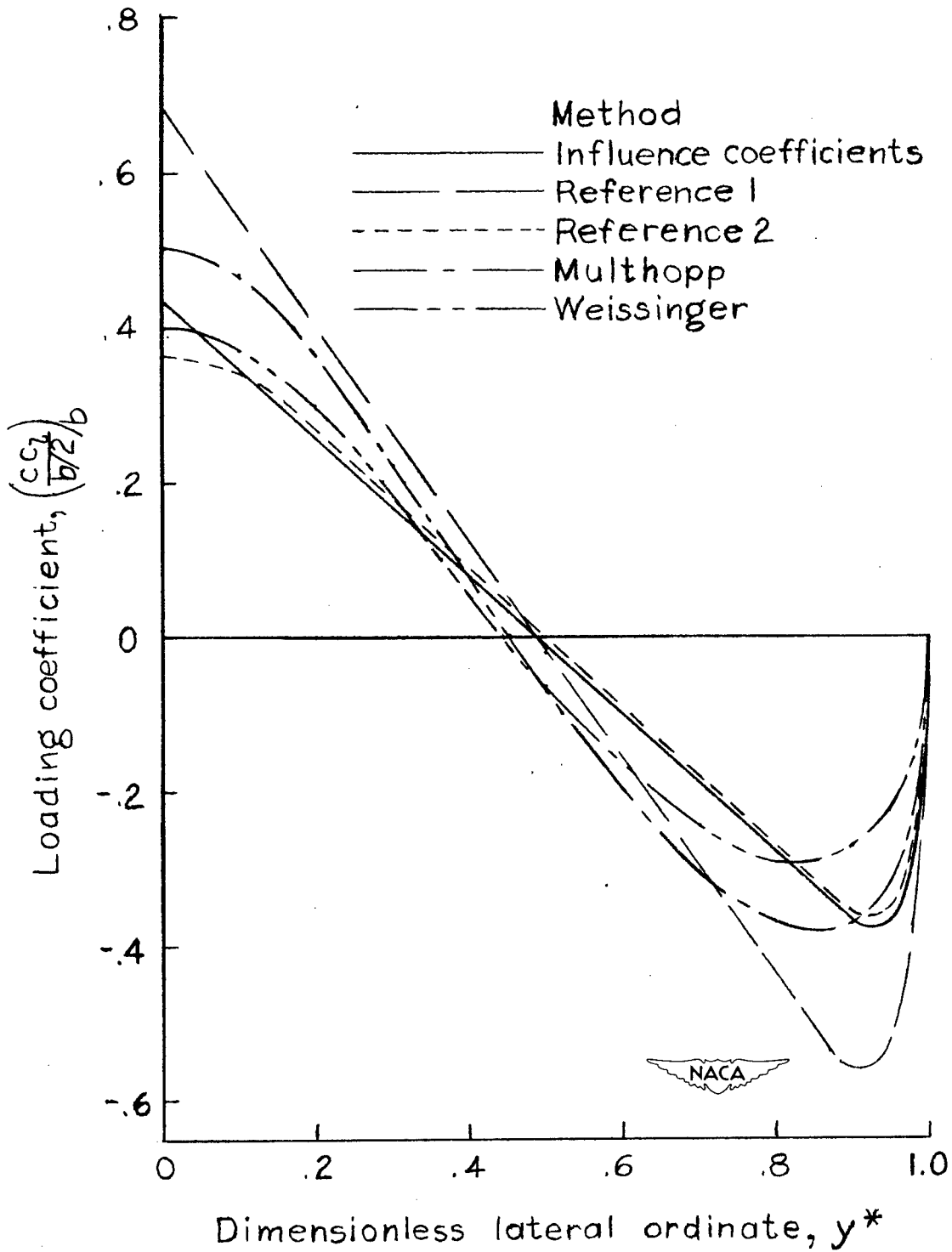

Figure 4.- Basic lift distribution of rectangular wing of aspect ratio 5 with unit linear symmetric twist in incompressible flow.