

NACA TN 1896

# NATIONAL ADVISORY COMMITTEE FOR AERONAUTICS

**DUPLICATE** TECHNICAL NOTE 1896  
**ATI No 56195**

IMPROVEMENT OF ACCURACY OF BALANCED-PRESSURE INDICATORS  
AND DEVELOPMENT OF AN INDICATOR CALIBRATING MACHINE

By James C. Livengood

Massachusetts Institute of Technology



**Reproduced From  
Best Available Copy**

Washington

June 1949

20000731 184

**DISTRIBUTION STATEMENT A**  
Approved for Public Release  
Distribution Unlimited

**DIC QUALITY INSPECTED 4**

AQM00-10-3348

**DUPLICATE**

**ATI No 56195**

NATIONAL ADVISORY COMMITTEE FOR AERONAUTICS

TECHNICAL NOTE 1896

IMPROVEMENT OF ACCURACY OF BALANCED-PRESSURE INDICATORS  
AND DEVELOPMENT OF AN INDICATOR CALIBRATING MACHINE

By James C. Livengood

SUMMARY

In an investigation to improve the accuracy of balanced-pressure indicators, the most serious error in light-spring diagrams made with a conventional clamped-diaphragm balanced-pressure indicator was found to be a zero shift due to elastic stress in the diaphragm. This error can be reduced to negligible proportions by leaving the edges of the diaphragm free, thus eliminating the practice of clamping the edges of the diaphragm between the backing plates. The use of such a free-diaphragm unit affords a means of obtaining very satisfactory light-spring diagrams from a high-speed engine.

It was found that both clamped- and free-diaphragm units have an uncertainty of about  $\pm 30 \times 10^{-6}$  second in time response when the rate of pressure change  $dp/dt$  is 20,000 to 30,000 psi per second. This uncertainty was unaffected by considerable changes in the mass, stiffness, and travel distance of the diaphragm. The introduction of a restricted passage between the diaphragm and the cylinder had a relatively small effect on diaphragm response to moderate rates of pressure change.

Electrical indicators tested did not appear to be suitable for light-spring diagrams. A sampling-valve indicator was unsatisfactory because of the length of time (0.001 sec) during which the valve was open; this caused distortion in the response to transients.

A rotating valve has been developed which makes it possible to test and compare indicator pickup units in a manner which shows both their responses to transient pressure change and the presence or absence of error in measuring pressure level. This valve is similar to the familiar three-way valve, but is made in disk form. Rates of pressure change of 30,000 psi per second are easily obtained; this compares with the rates usually encountered in light-spring diagrams from internal-combustion engines.

INTRODUCTION

The accurate measurement of the pressures existing during the inlet and exhaust processes of the internal-combustion-engine cycle is a difficult problem. Although the rate of pressure rise is relatively low and

the dynamic errors may be reduced in consequence, the sensitivity must be very great in order that it may record the small changes in pressure occurring during these parts of the cycle. This requirement for high sensitivity necessitates the use of a primary measuring element with small errors due to mass, stiffness, and damping. In the case of the conventional balanced-pressure indicator, this objective can be reached by reducing the diaphragm motion; obviously, if the diaphragm did not have to move at all when the unknown pressure reached the value of the balancing pressure, there would be no dynamic error. There could, of course, be a static zero error.

Experience has indicated, however, that the diaphragm motion must not be too small or the electrical contact will cause erratic behavior and poor diagrams of the engine cycle. Since the motion of the diaphragm cannot be indefinitely small, the use of a flexible diaphragm is desirable in order to reduce the error due to elastic stress in the diaphragm as it flexes during the cycle. But such a flexible diaphragm must be supported by perforated backing plates in order to limit its motion to a small amount during the part of the cycle when the unknown pressure is not equal to the balancing pressure. A question then arises as to the effect of the backing plates upon the diaphragm motion.

Aside from the possibility of a damping lag introduced by the backing plates, it can be stated with certainty that there is a lag due to the mass of the diaphragm. With the assumption that stiffness and damping are negligible, this time lag  $\Delta t$  can be shown to be:

$$\Delta t = K \left( \frac{mh}{CA} \right)^{1/3}$$

where

- m            mass of diaphragm in motion
- h            diaphragm travel necessary for recording
- A            diaphragm area
- C            time rate of pressure change
- K            constant dependent upon dimensions of units used

If it is assumed that the entire diaphragm moves, this can be expressed as

$$\Delta t = K_2 \left( \frac{y \xi h}{C} \right)^{1/3}$$

where

$y$             diaphragm thickness  
 $\xi$             density of diaphragm material  
 $K_2$            constant dependent upon units used

Since the pressure error  $\Delta p = C \Delta t$ ,

$$\Delta p = C^2/3K_2(y\xi h)^{1/3}$$

This is the equation for the pressure error of a balanced-pressure indicator having a diaphragm with negligible stiffness and no damping.

The justification of the preceding assumptions is not clear in the actual pickup unit of the balanced-pressure indicator. Accordingly, it was proposed to develop a means for determining experimentally the effect of changes in the important design parameters. The experiments were arranged specifically to determine these effects under conditions approximating those existing in the low-pressure parts of an engine cycle. This region of the cycle is of especial interest because the thermodynamic analysis of the combustion process depends upon a knowledge of the initial conditions of state of the cylinder contents before compression. It is also of interest in the study of volumetric efficiency and pumping losses.

In the absence of a standard indicator, the logical approach to the problem appears to be to conduct comparative tests of indicators with many different design features. This method was used by Caldwell and Fiock (reference 1) in their work on explosion pressures in constant-volume bombs.

For the purpose of determining by comparison the effects of design changes in a particular indicator or of comparing the responses of different types of indicator, a machine was needed which would produce a pressure which varied with time in a known manner; further, in order to study indicators of the point-by-point type, it was desirable that this pressure-time function repeat itself precisely with a reasonably high repetition rate. Two methods for achieving this end appeared to be promising:

The first method consisted in enclosing a known mass of a gas with known properties and then changing the volume of the gas in a known cyclic manner. The simplest cycle should be adiabatic and isentropic.

The second method consisted in establishing two reservoirs operated at different static pressures; a third small reservoir then to be connected alternately to the two steady-pressure reservoirs. Thus, after

brief transient periods, the pressure in the third reservoir would be equal, alternately, to the two steady pressures. The assumption in the second method is that the pressure in the third small reservoir will come to equilibrium with the steady pressure during the limited time available.

Although the second method would not yield complete knowledge of the pressure-time function, it would provide a cycle which could be repeated quite precisely and which contained two established pressure levels. The first method appeared to offer more serious objection, both because of the necessary thermodynamic assumptions and the difficulty of varying a sealed volume in a sufficiently precise manner.

This investigation was made at the Sloan Laboratories for Automotive and Aircraft Engines, Massachusetts Institute of Technology, under the sponsorship and with the financial assistance of the National Advisory Committee for Aeronautics.

## APPARATUS

### Description of Square-Wave Calibrating Valve

The elements of the valve which was used to apply alternately the two steady pressures to the indicator pickup units can be seen in the assembly drawing (fig. 1) and in the photograph (fig. 2). The valve is simply a three-way valve made in disk style instead of the more familiar plug type.

The valve consists of two cast-iron boxes which form the steady-pressure supply reservoirs and also serve as a supporting structure for the remaining parts. Between these boxes two thick side plates, cast from Meehanite, are clamped. Each side plate contains two threaded openings for indicator pickup holes. These ports register with similar openings in the boxes, thus communicating with the pressure reservoirs.

The side plates are separated by a steel annulus. Between the side plates and inside the annulus is the rotating valve disk. This disk is made of steel and is finished with hard chromium plate. It floats freely on a spherical region in the center of the drive shaft and is driven by means of a small pin which engages a keyway in the center bore of the disk. The valve disk (fig. 3) has two long annular ports, cut through the disk. These ports are the means by which the pickup units communicate with the stationary ports in the side plates. These ports in the rotating disk are long enough to overlap either pair of pickup unit holes and either pair of the stationary side-plate ports; but they are so short that the reservoirs containing different pressures cannot ever communicate with each other. A schematic operating cycle is shown in figure 4(a). If a pair of pickup units mounted adjacently are considered, then from point A to point B the units are in communication with each other and also with the pressure reservoir  $P_2$ . From B to C they are in

communication with each other only; from C to D they are in communication with each other and with the pressure reservoir  $P_1$ ; from D to E the units are separated by a solid portion of the valve disk and neither is in communication with either of the pressure reservoirs. The portion of the cycle E-F-G-H-A is similar to A-B-C-D-E except that the other rotating port is in action for the pair of units considered.

The reason that the flat "top" portion of the wave is of longer duration than the lower part is that each stationary pressure-supply port extends over a considerable angle and the pickup holes themselves occupy several degrees. If the direction of rotation of the disk is reversed, the cycle shown in figure 4(b) will be followed. The important thing which should be noted is that the solid-line portions of these cycles are the only regions wherein a comparison of pickup units is always permissible; in other portions of the cycles, the units are either not in communication with each other or are in transient states which do not necessarily start from the same initial state. In the dashed-line portions of the cycles the units are in communication with each other and probably have recovered from any effect of transient changes from different initial states.

The valve assembly was supported between two tanks, as shown in figure 5. Large flow passages were provided from these tanks into the pressure reservoirs in the cast-iron boxes of the valve assembly. Suitable gages and manometers were provided for measuring the pressures in the tanks.

#### Recording Apparatus

A reversible direct-current motor provided variable-speed drive, and an extension shaft from the same motor was used to drive the recording drum of the M.I.T. high-speed indicator. Other apparatus used consisted of a cathode-ray oscillograph and suitable amplifiers and marker circuits for observing the output of electronic pickup units; a high-speed strip camera of M.I.T. design was used for photographing the oscillograph trace.

For measurement of very short time intervals a synchroscope was used. This instrument is a cathode-ray oscillograph with calibrated sweep speeds as high as  $1.35 \times 10^6$  inches per second. Provision is made to initiate the sweep either upon application of the transient being studied or by means of a signal from an external contactor.

#### Types of Indicator Tested

Most of the tests were conducted with balanced-pressure pickup units of M.I.T. design (fig. 6). These units are quite conventional and are designed for reasonable compactness and ease of manufacture. As can be seen in figure 6, these units have a clamped diaphragm, and it is quite

likely that upon assembly an elastic deformation of the diaphragm will occur either toward or away from the electrical contact. Unless the clearance for diaphragm motion is so large that buckling occurs ("oil-can" effect), this condition should not affect the measurement of pressure differences, but it will, of course, result in inaccurate absolute-pressure determinations because of the elastic "zero shift." In order to avoid this zero shift, a pickup unit with a free diaphragm was developed. It is the same as the unit shown in figure 6 except that the diaphragm is not clamped but floats in a recess cut in one of the backing plates as shown in figure 7.

An electrically operated sampling valve was also tested. This device has a small poppet valve with its seat at the end of the threaded mounting shell. A contactor driven by the direct-current driving motor was used to discharge a condenser through a solenoid. This surge of current applied an impulse to an armature which opened the poppet valve briefly (about 0.001 sec, according to the manufacturer of the unit). The discharge pressure from the sampling valve was measured by a manometer after equilibrium was reached.

A magnetic pickup designed at M.I.T. was used for some measurements. It is described in reference 2, and it has a stiff steel diaphragm with a first-mode natural frequency of 90,000 cycles per second. Its output is proportional to  $dp/dt$ .

A quartz-crystal piezoelectric pickup unit of commercial design was used for comparison with the balanced-pressure units. It was used in conjunction with suitable amplifiers and a cathode-ray oscillograph.

## RESULTS AND DISCUSSION

### Calibrator Performance

The assumption that the pressure level at the pickup unit reached the value of the pressure in the steady-pressure reservoir was checked by means of the electrically operated sampling valve. Figure 8 shows a record obtained with this device. For comparison, a record made with a free-diaphragm balanced-pressure unit is superimposed upon the sampling-valve data. At any particular sampling point, the equilibrium pressures plotted are intermediate between the pressures in the cycle at beginning and end of the sampling-valve opening period. If these pressures are only slightly different, the approximation will be good; with high rates of pressure change, the distortion is serious. This method of obtaining pressure records proved to be exceedingly tedious, but it was demonstrated that the pressure at the pickup location in the square-wave calibrator, after the transient change, oscillated about the steady-pressure level in the reservoir.

### Zero Shift

The clamped-diaphragm units frequently exhibited a zero shift due to clamping stresses in the diaphragms. Tests were conducted to determine whether this zero shift, as measured statically with a manometer, would agree with the shift of the square-wave diagram under dynamic conditions. Almost without exception the agreement was within  $\pm 0.2$  inch of mercury. The width of the spark-recorded line on the diagrams made it impracticable to read pressures much closer than  $\pm 0.1$  inch of mercury on the largest-scale diagram.

### Effect of Pickup Location

A series of tests was made to determine whether the locations in the machine of two units being compared had a measurable effect upon the responses of the units. Figure 9 shows the result of such a test. A free-diaphragm unit was used for this test to avoid a zero shift. Since the natural frequency of such a diaphragm is low, the response to the rapid pressure variation in the acoustic vibration region is poor. The behavior when  $dp/dt$  is high, in the transient region, discloses no appreciable differences in the form of the pressure wave at the two locations. Other tests showed a similar agreement.

### Effect of Diaphragm Motion

A further series of tests was made to determine the effect of diaphragm clearance on the performance of the free-diaphragm unit. Figures 10(a) to 10(d) illustrate this effect. It will be noticed that the detail in the response to the acoustic waves improves as the clearance is reduced. This effect has been noted in clamped-diaphragm units also. The lower limit in units of this design, with diaphragms of 0.0015-inch-thick steel, appears to be from 0.005 to 0.0015 inch of diaphragm travel. If the motion is too small, the detail in the records is suppressed, and the unit may become entirely inoperative. Even for the extremes of clearance used for the diagrams in figures 10(a) to 10(d), however, the response to rapid pressure change (28,000 psi/sec) was not measurably affected, and the steep sides of these diagrams "fit" almost perfectly when superimposed.

The general behavior of the free-diaphragm unit was encouraging; where the clamped-diaphragm units often exhibited a change in the elastic zero shift during operation ("shake-down"), this never occurred in the free-diaphragm unit. In fact, the free-diaphragm unit seldom exhibited any trace of elastic zero shift. Some doubts were held concerning the use of this unit in a firing engine, but these were later at least partially dispelled.

### Effect of Restrictions

Some experiments were made to determine the effect of reduction in the connecting passages between the pressure being measured and the pickup unit. For this measurement, two adapters were used (fig. 7). One had a small cross-sectional area and the other, a large area. Figure 11 shows a typical result with the large adapter. The two diagrams were made on the same sheet while on the recording drum. The agreement is fair, even in the steepest portion of the cycle, although there is a suggestion of a more slowly rising pressure at the end of the adapter passage.

Figure 12 shows the superimposed diagrams from units with and without the small-adapter passage. Again, there is a perceptible difference, although not so large as might have been expected. Note that this diagram was made with the direction of rotation reversed so that the time scale is backward; also, the rising pressure transients start from the same initial pressure, but the falling transients do not. (See fig. 4(b)).

### Effect of Perforated Backing Plates

The effect due to damping of the air and diaphragm motions by the backing plates was investigated by comparing the responses of units with the standard design of backing plates (small holes) and with very large holes, as shown in figure 7. The differences in response are not systematic, as can be seen in figure 13, except in the region of the diagram where agreement cannot be expected (explained under APPARATUS). Of course, a unit with such large holes in the backing plates would fail almost immediately in an engine because of inadequate diaphragm support; but the use of small holes apparently does not cause serious distortion in the response when  $dp/dt$  is comparable with the  $dp/dt$  in the low-pressure part of an engine cycle.

### Detection of Small Errors in Response Time

The foregoing tests showed that pickup units constructed in accordance with figure 6 could be expected to yield accurate responses to the low-pressure parts of an engine cycle, except for the elastic zero shift experienced with clamped diaphragms, and that this difficulty may be substantially reduced by the use of free (unclamped) diaphragms. It is obvious, however, that there must be small errors due to diaphragm inertia and damping effects. With rates of pressure rise of 20,000 or 30,000 psi per second, these errors are too small to be measured with recording-drum speeds as high as 2000 rpm. This corresponds to a linear speed of 300 inches per second. On the spark-recorded diaphragm, measurements could be made, in the limit, within about  $\pm 0.01$  inch, which corresponds with  $\pm 0.000033$  second (33 microsecond). It was felt that there might be systematic differences in the pickup responses which could be hidden within this region of uncertainty.

For the investigation of this possibility the synchroscope was used to indicate accurately the difference in time between the instant of diaphragm contact in one unit and that in another when the units were subjected to the same pressure wave in the square-wave valve. Two "identical" clamped-diaphragm units were assembled and checked for zero shift. When tested as described, it was found that the time difference in diaphragm motions varied erratically from 0 to about 25 microseconds. Neither unit consistently lagged behind the other, and this resulted in a total spread of about 50 microseconds. This erratic behavior was not appreciably changed by gold plating on the diaphragms and contacts. When the diaphragm clearance was increased in one of the units (in an attempt to cause a delay in recording by increased travel time), this unit still recorded earlier some of the time. Free-diaphragm units showed the same erratic behavior and about the same spread in results. It is not known whether this phenomenon is a peculiarity of the square-wave valve and measuring apparatus or whether it is caused by the pickup units themselves. The attempt to discover systematic trends in pickup behavior failed, however, because of this uncertainty. The experiment showed, however, that the design changes tried (variations in diaphragm mass, motion, and damping) did not result in changes in response any greater than the existing uncertainties. Any of the units tested should be suitable for engine tests at moderate rates of pressure change (up to 30,000 psi/sec) provided, of course, that the unit is rugged enough to withstand the peak pressures and the temperature effects.

#### Tests with Other Types of Indicator

The use of the sampling-valve indicator has already been mentioned. Its use for light-spring (low-pressure) diagrams was very slow because of the long time required for establishment of pressure equilibrium at each selected sampling point. It was also unsuitable for measurement of rapidly changing pressures because of the comparatively long duration of the sampling period.

The M.I.T. magnetic pickup unit was used first for measurement of the frequency of the acoustic vibrations in the square-wave valve after each transient pressure change. Since its output is proportional to  $dp/dt$ , the record shown in figure 14 is the time derivative of the pressure function created by the square-wave valve. The acoustic vibrations have a frequency of approximately 600 cycles per second. It was noted that the presence of the steel valve disk rotating near the pickup caused quite a disturbance (fig. 15). This fact may be a handicap in the application of magnetic circuits to measurements in engines unless precautions are taken to avoid such stray field effects.

The quartz-crystal pickup, when used with suitable amplifiers, gave a very good wave form (fig. 16), and when it was checked against a balanced-pressure unit by means of marker circuits, there appeared to be no noticeable phase-shift effects. The output of the quartz element, however, is so small that high-gain amplifiers must be employed for

obtaining low-pressure diagrams of usable size. The attendant difficulties with hum and other interference would seem to limit the usefulness of the device for light-spring diagrams. Much more serious was the sensitivity of the pickup to mechanical vibration. This trouble was not present with the square-wave valve because this apparatus runs smoothly with very little vibration, but it proved impossible to obtain good low-pressure diagrams in a firing engine, largely because of the response to engine vibrations. Another disadvantage of the piezoelectric unit is that it gives pressure differences only, with no indication of the pressure level.

### Engine Tests

A few tests were performed in a CFR engine. The engine was operated under the following conditions:

speed, rpm . . . . .	1200
manifold pressure, in. Hg abs. . . . .	29.0
exhaust pressure, in. Hg abs. . . . .	30.1
spark advance, °B.T.C . . . . .	16
compression ratio . . . . .	6
fuel . . . . .	100-octane aviation gasoline
fuel-air ratio . . . . .	0.075
barometer, in. Hg . . . . .	30.1

Figures 17(a) and 17(b) show the results obtained from clamped- and free-diaphragm units. In addition, the effect of using the small adapter (fig. 7) between the cylinder and pickup is shown. The most interesting effect of this adapter is the long "spike" produced at the top of the high-pressure diagram. This spike may be due to combustion of gases within the adapter passage. In figure 17(b) it will be noted that the adapter passage decreased the amplitude of the oscillation during the exhaust period. The detail in the original diagram was improved also, and it may be that resonance of some sort was excited in the clamped diaphragm; the adapter passage could be expected to produce some damping. The use of connecting passages for mounting indicator pickup units appears to be a questionable procedure. The merit of any particular arrangement should be checked by experiment before it is assumed that the pressures measured are correct.

The useful life of the free-diaphragm unit was found to be in excess of 4 hours under conditions approximating those listed. It is not expected that its life will be as great ordinarily as that of the clamped-diaphragm unit. Some of the latter units have been observed to perform well after 15 to 20 hours of operation, even when fitted with 0.0015-inch-thick steel diaphragms.

### Effect of Thermal Gradients on Diaphragm Behavior

The experiments with the square-wave valve indicate that light-spring diagrams made with balanced-pressure pickup units have only negligible dynamic errors. Furthermore, units with free diaphragms are free from zero shift at room temperature. Since the diaphragm is entirely free, thermal effects in the body of the pickup unit can have no effect upon diaphragm behavior. However, the effect of temperature gradients in the diaphragm itself has not been determined. It is suggested that this effect could be determined by inserting a window in one of the pickup unit holes of the square-wave valve so that a spot of light from a strong arc could be focused on the diaphragm of a pickup in the adjacent hole. The light would be cut off periodically by the disk valve. In this way the pickup could be tested both with and without a dynamic temperature effect.

### CONCLUSIONS

In an investigation to improve the accuracy of balanced-pressure indicators, it was found that:

1. In light-spring diagrams, where the maximum rate of pressure change  $dp/dt$  does not exceed 30,000 psi per second, the most serious error found in the balanced-pressure pickup units was the zero shift caused by elastic stress in the diaphragm.
2. The zero shift can be greatly reduced by the use of thin, free (unclamped) diaphragms.
3. The errors introduced by the presence of well-perforated backing plates are not detectable in light-spring diagrams.
4. The transient-time effects in the pickup units tested were erratic. There appear to be uncertainties of the order of  $\pm 30 \times 10^{-6}$  second when  $dp/dt$  is 20,000 to 30,000 psi per second.
5. Small connecting passageways between the pickup and the engine cylinder should be avoided.
6. Excessive clearance for diaphragm motion causes loss of detail in the record. The lower limit of diaphragm travel is about 0.001 inch when thin diaphragms are used.
7. The sensitivity to engine vibration of the piezoelectric pickup which was tested made it unsuitable for light-spring measurements in an engine. However, excellent records were obtained with the square-wave test machine, which was quite free from vibration.

8. A magnetic pickup of M.I.T. design was unsuitable if moving masses of iron were nearby, because of the disturbance of the magnetic fields within the pickup.

9. The sampling valve tested was unsuitable for measuring rapid pressure changes because of the length of the open period. In addition, its operation was tedious because of the slowness with which the manometer reached equilibrium, even after the air volume in the manometer had been reduced to a minimum.

10. The square-wave valve described produces a reproducible pressure wave which oscillates alternately about the two steady pressures maintained in the supply tanks. Rates of pressure change of 20,000 to 30,000 psi per second are easily obtained.

Sloan Laboratories for Aircraft and Automotive Engines  
Massachusetts Institute of Technology  
Cambridge, Mass., June 5, 1947

## REFERENCES

1. Caldwell, Frank R., and Flock, Ernest F.: Some Factors Influencing the Performance of Diaphragm Indicators of Explosion Pressures. Res. Paper RP1368, Jour. Res., Nat. Bur. of Standards, vol. 26, no. 3, March 1941, pp. 175-196.
2. Draper, C. S., Lancor, J. H., and Davis, Leighton: The Application of an Electromagnetic Indicator to Internal Combustion Engine Problems. Jour. Aero. Sci., vol. 8, no. 1, Nov. 1940, pp. 7-16.

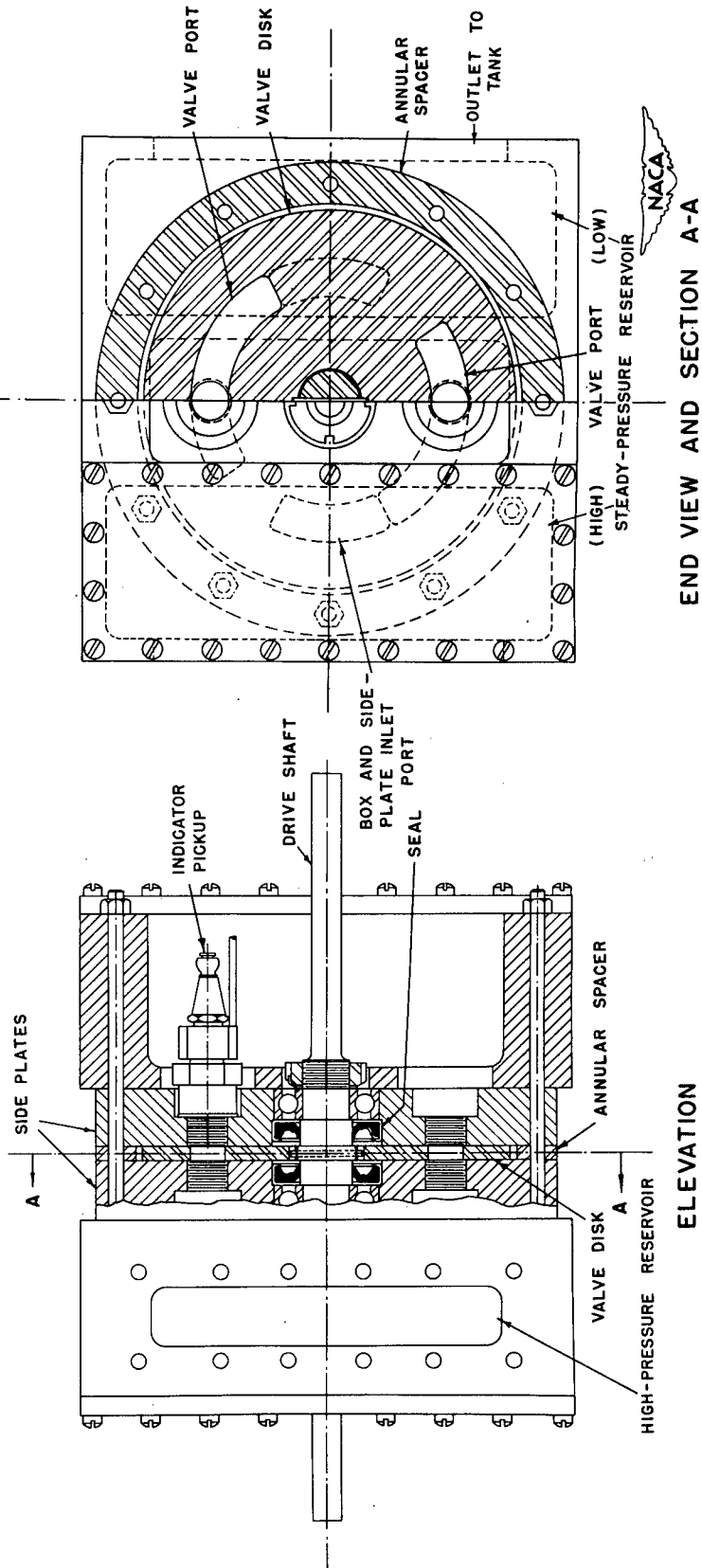

Figure 1.- Valve assembly.

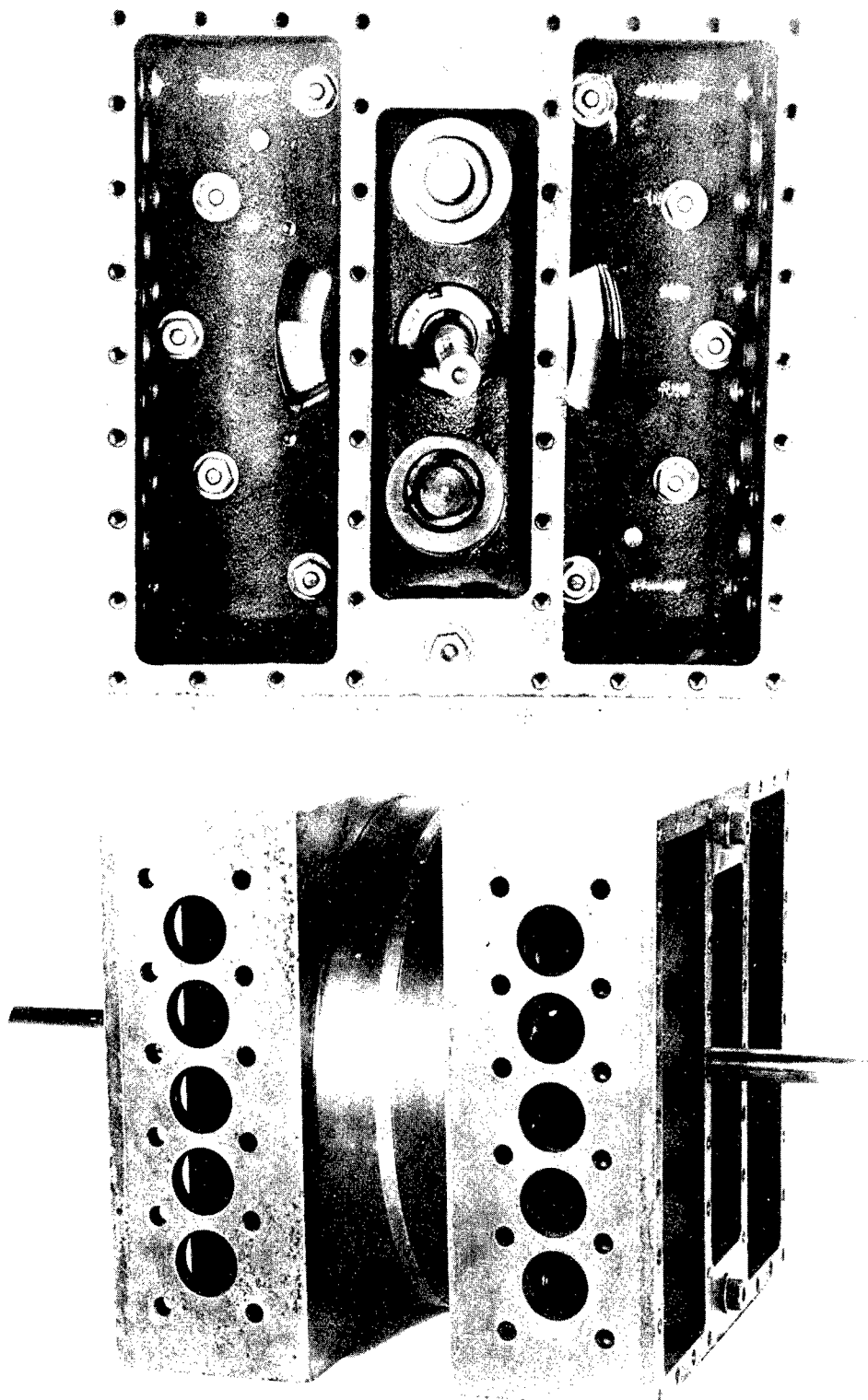

Figure 2.- Square-wave-valve assembly.



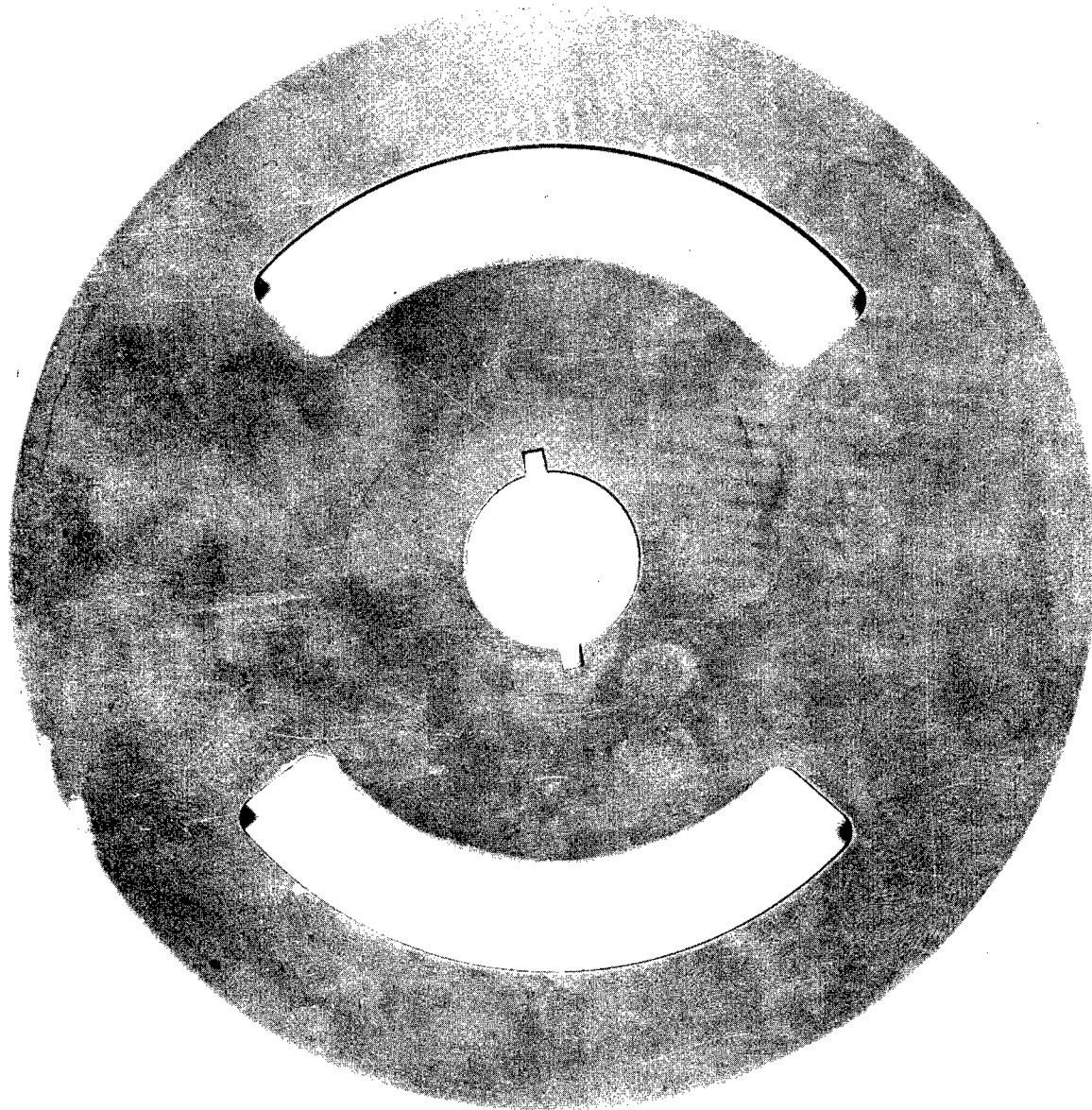

Figure 3.- Rotating valve disk.



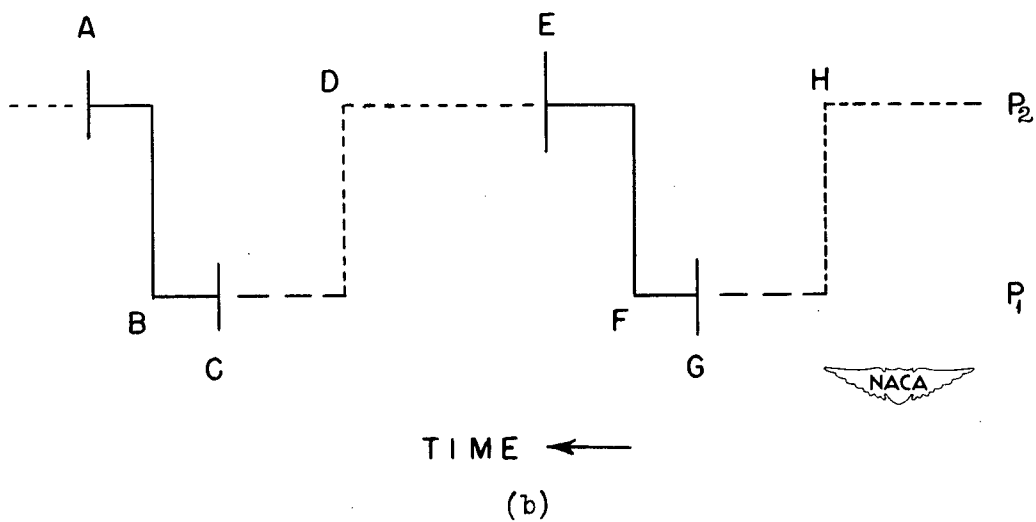
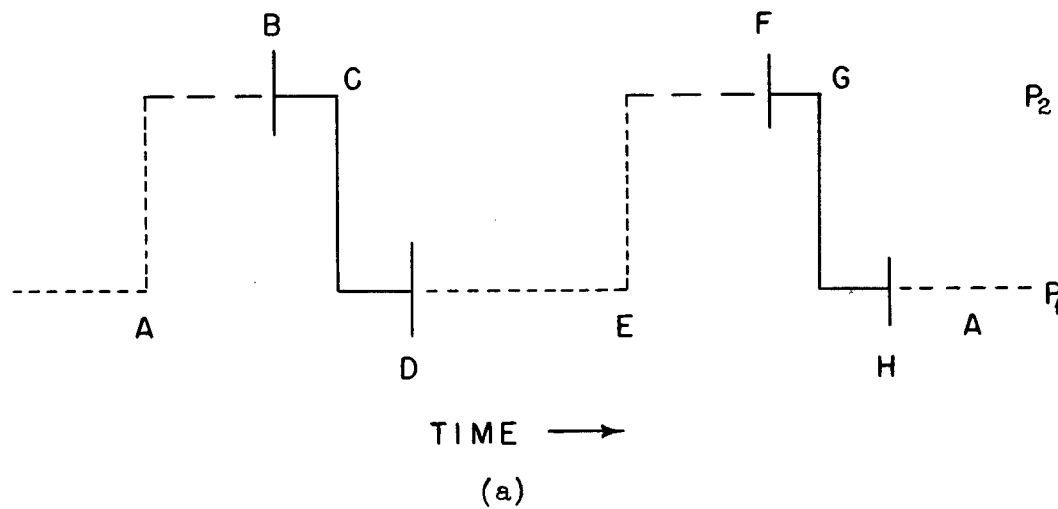

Figure 4.- Schematic square-wave cycles.

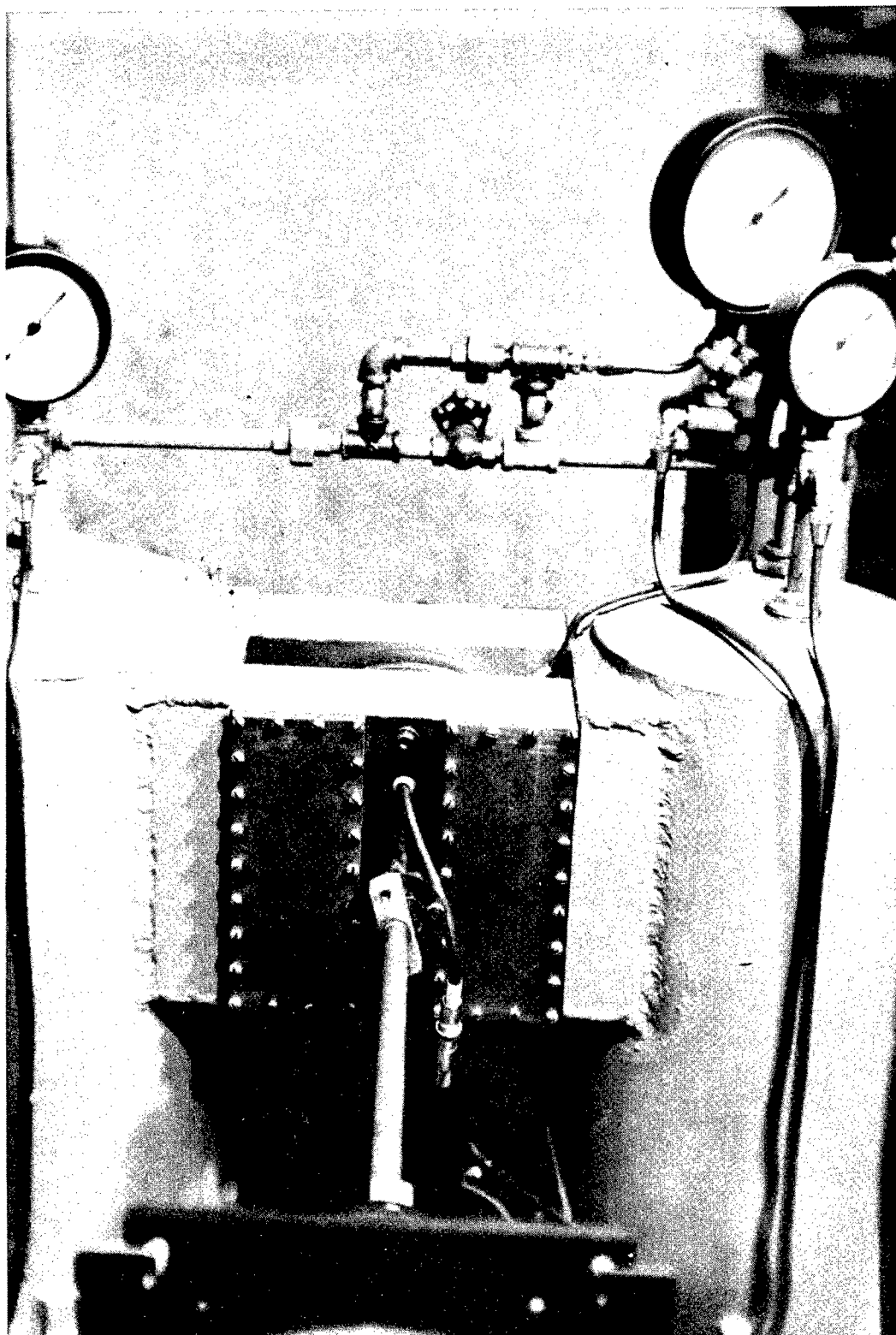

Figure 5.- Square-wave valve and tanks.

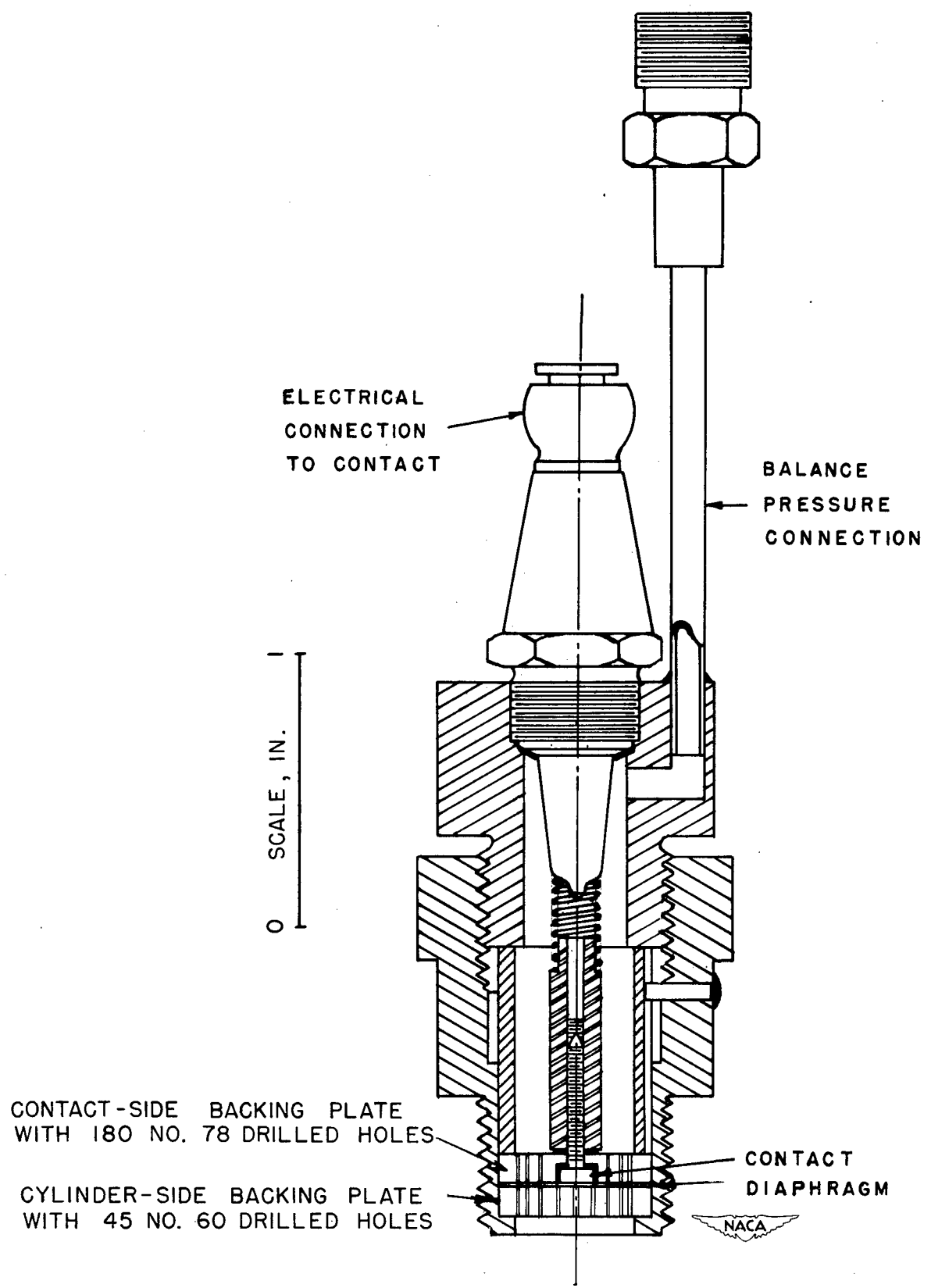
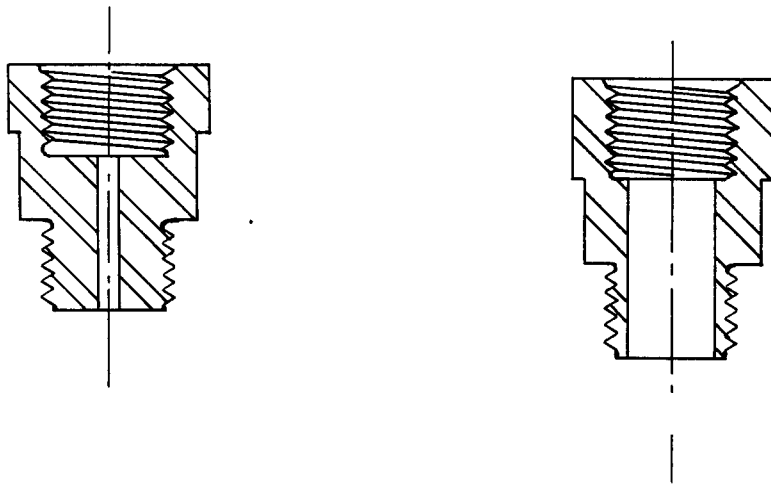
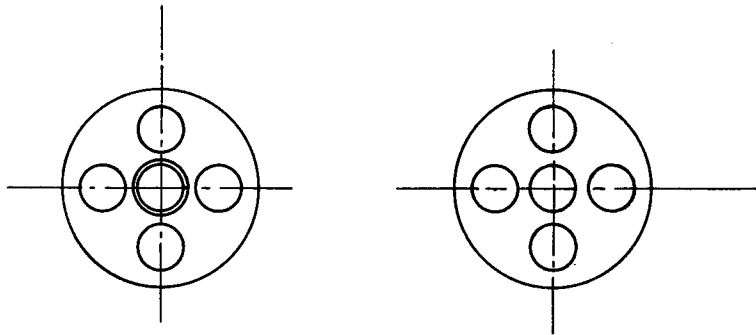

Figure 6.- Construction of pickup unit of M.I.T. balanced-pressure indicator.



(a) Small adapter (on left) and large adapter (on right). Full size.



(b) Backing plates with large holes. Double size.

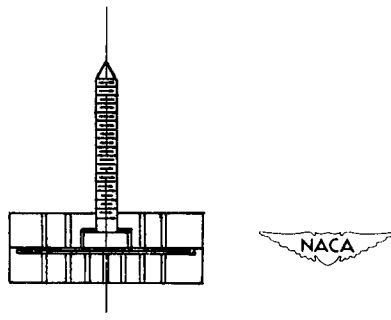

(c) Detail of free-diaphragm unit. Double size.

Figure 7.- Special adapters and backing plates.

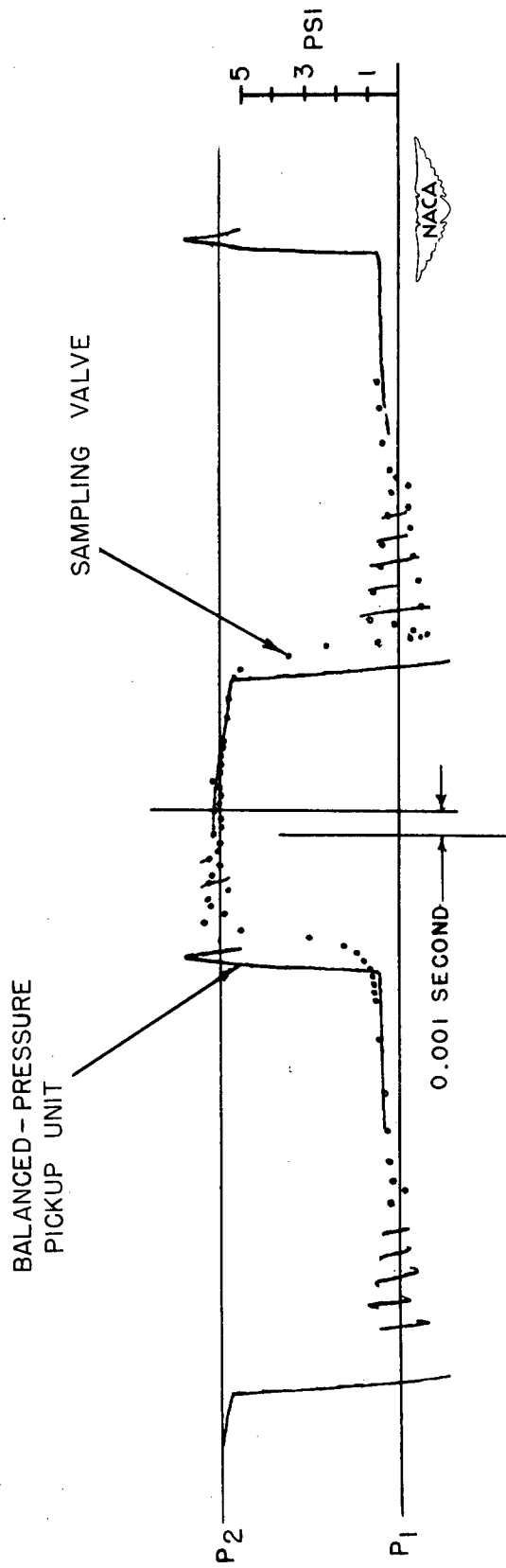

Figure 8.- Sampling-valve and balanced-pressure records.

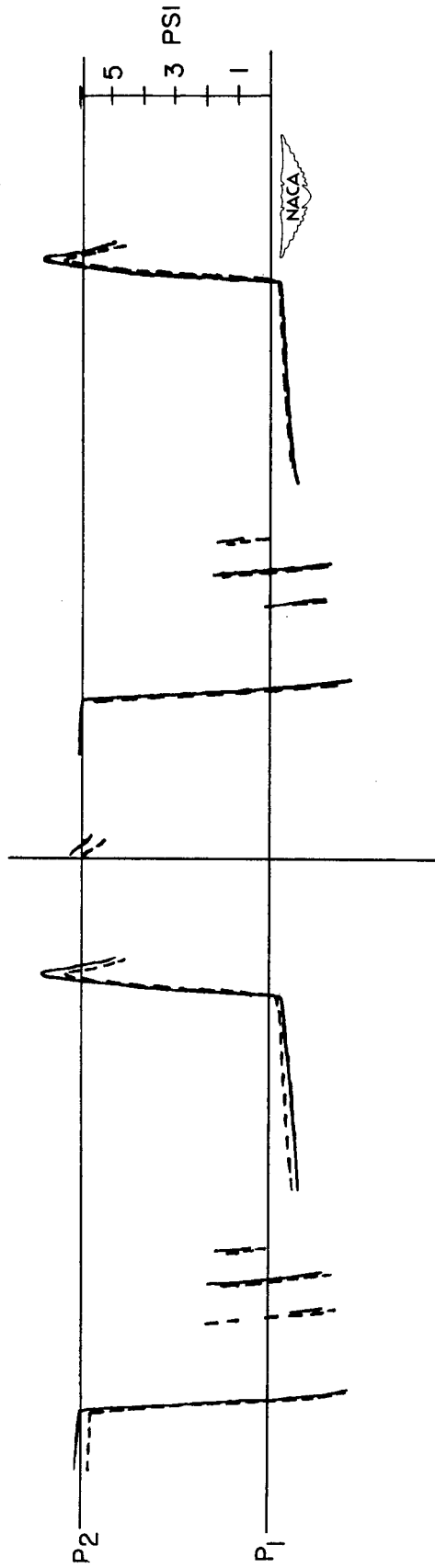
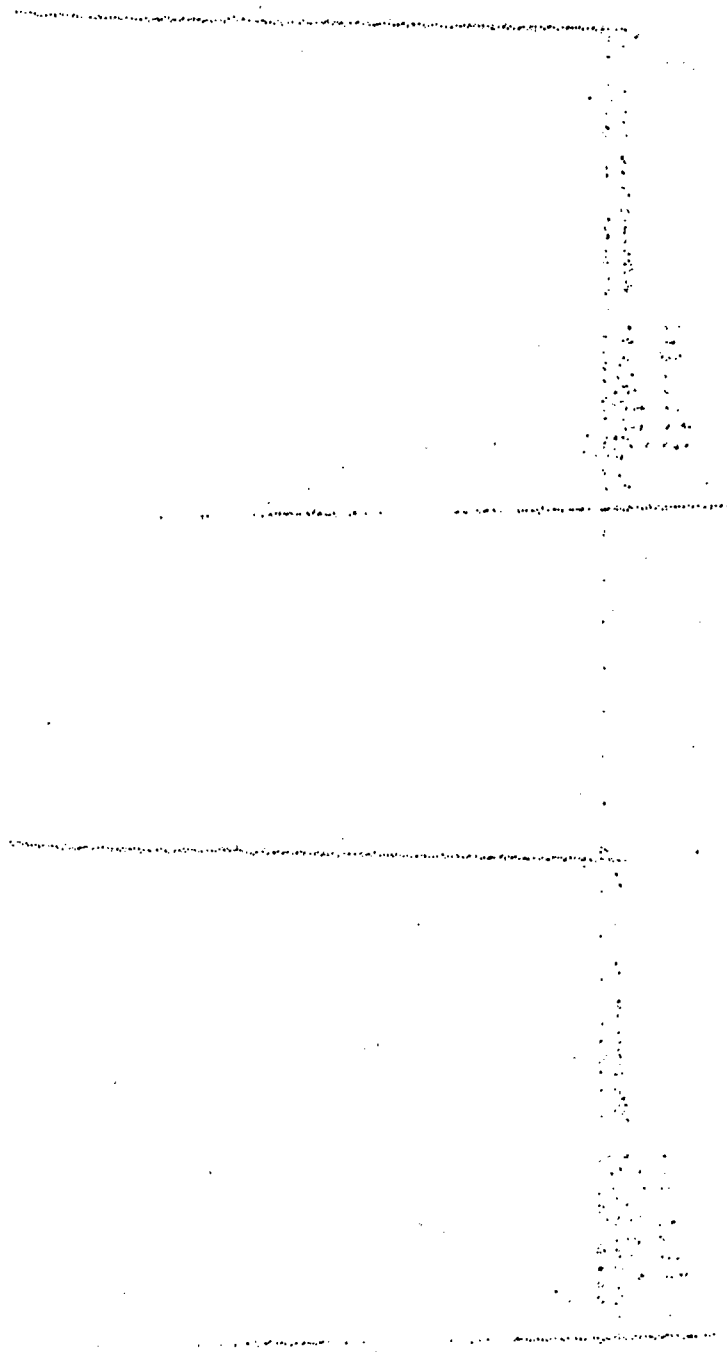
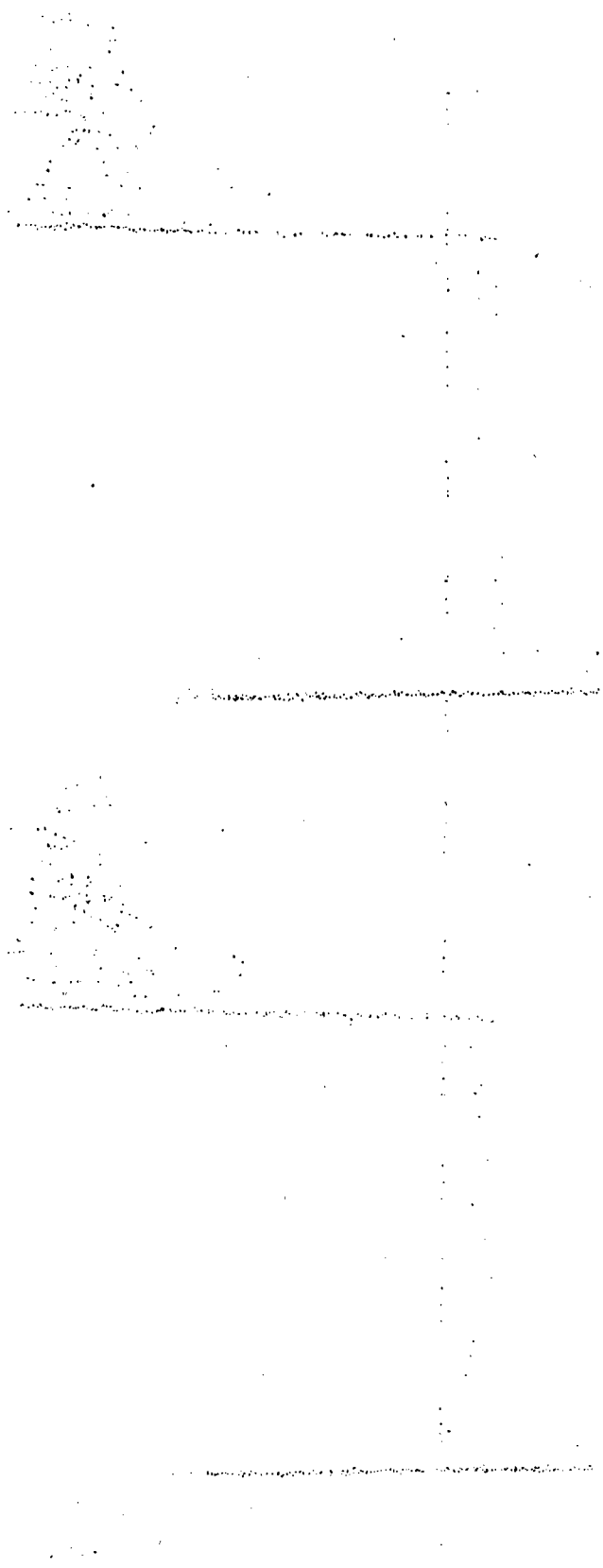

Figure 9.- Effect of pickup location in square-wave valve. Valve speed, 1500 rpm. Dashed and solid lines indicate two different pickup locations.



(a) Diaphragm motion, 0.009 inch.

Figure 10.- Effect of diaphragm motion on response. Valve speed, 1500 rpm.



(b) Diaphragm motion, 0.006 inch.

Figure 10.- Continued.

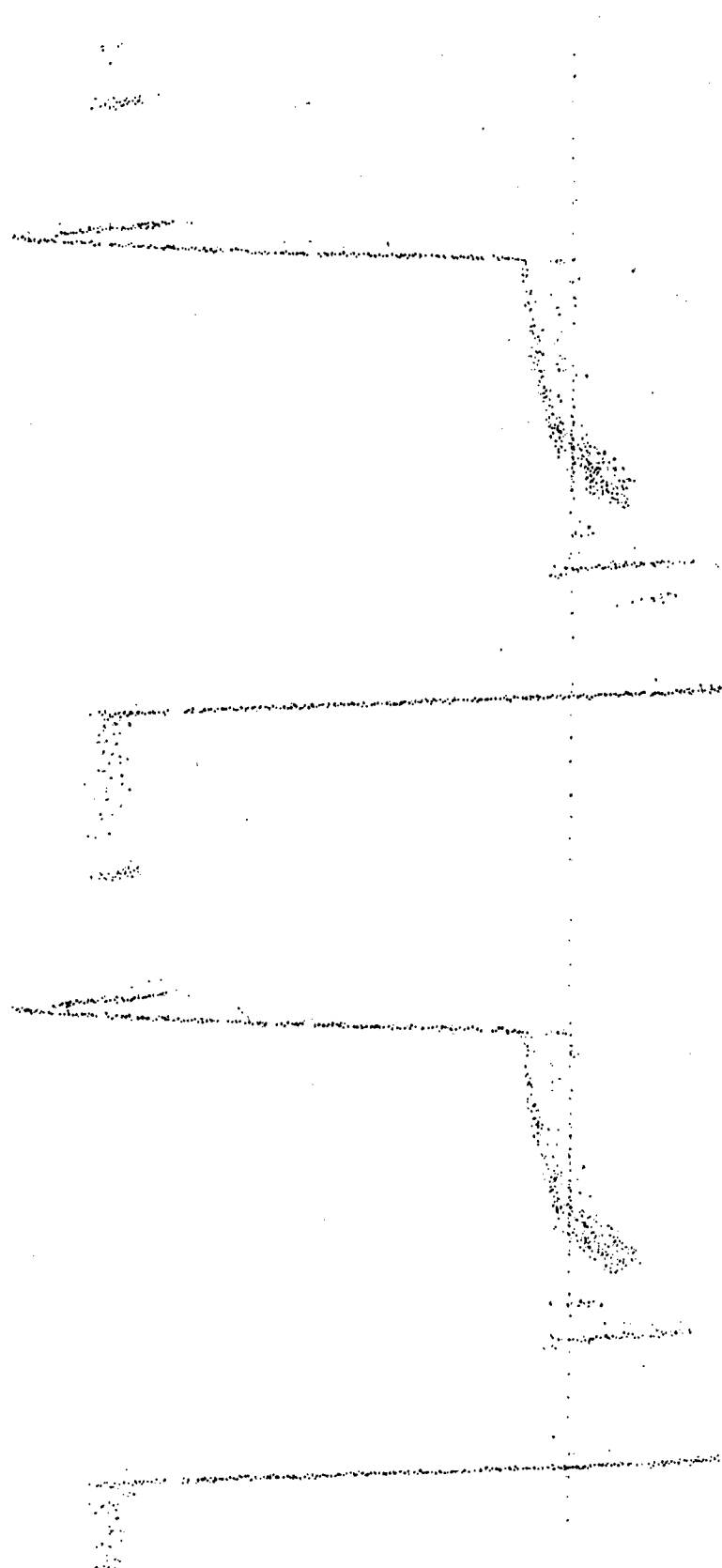

(c) Diaphragm motion, 0.0025 inch.

Figure 10.- Continued.

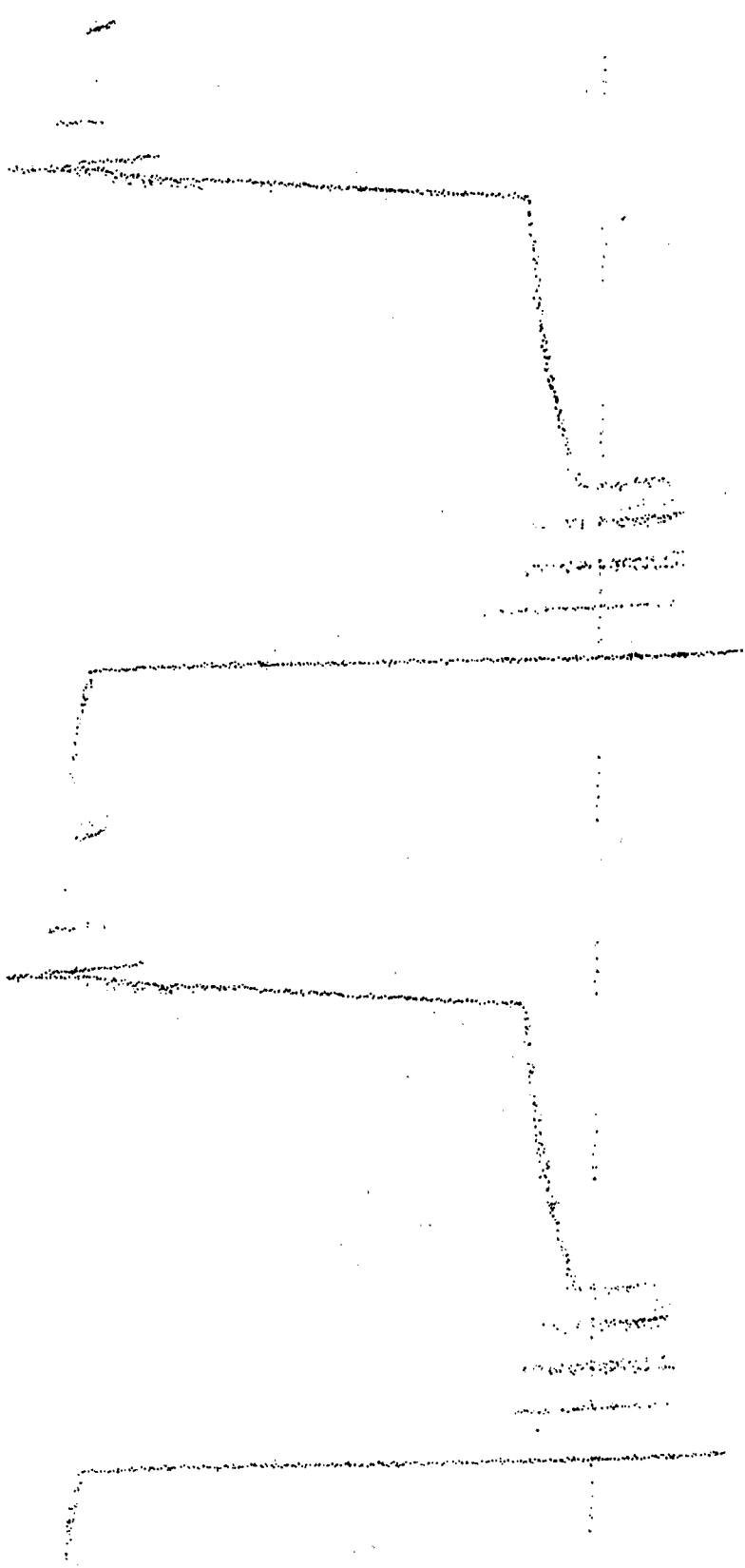

(d) Diaphragm motion, 0.002 inch.

Figure 10.- Concluded.

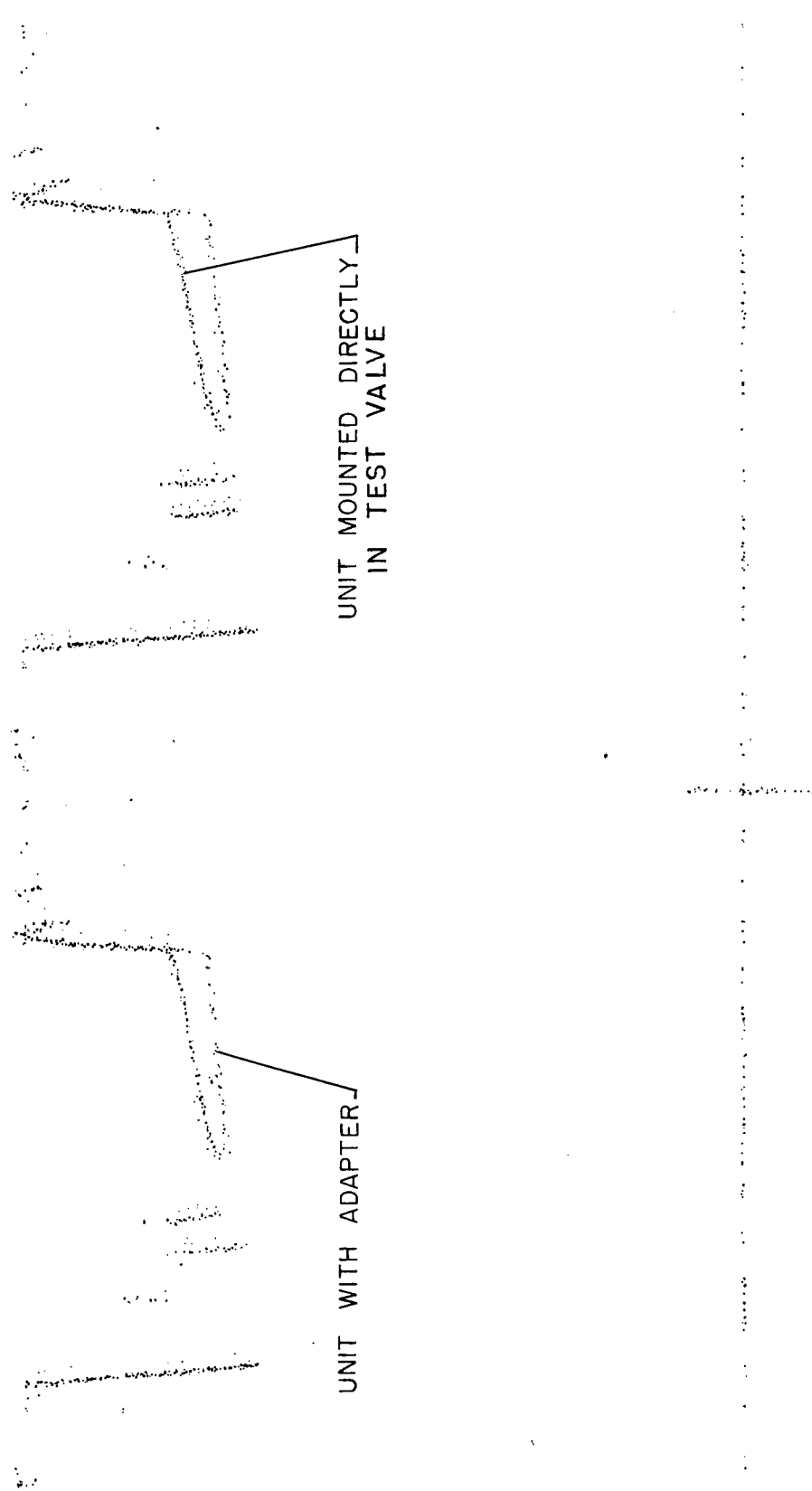

Figure 11.- Effect of connecting passage with large cross section. Valve speed, 1500 rpm.

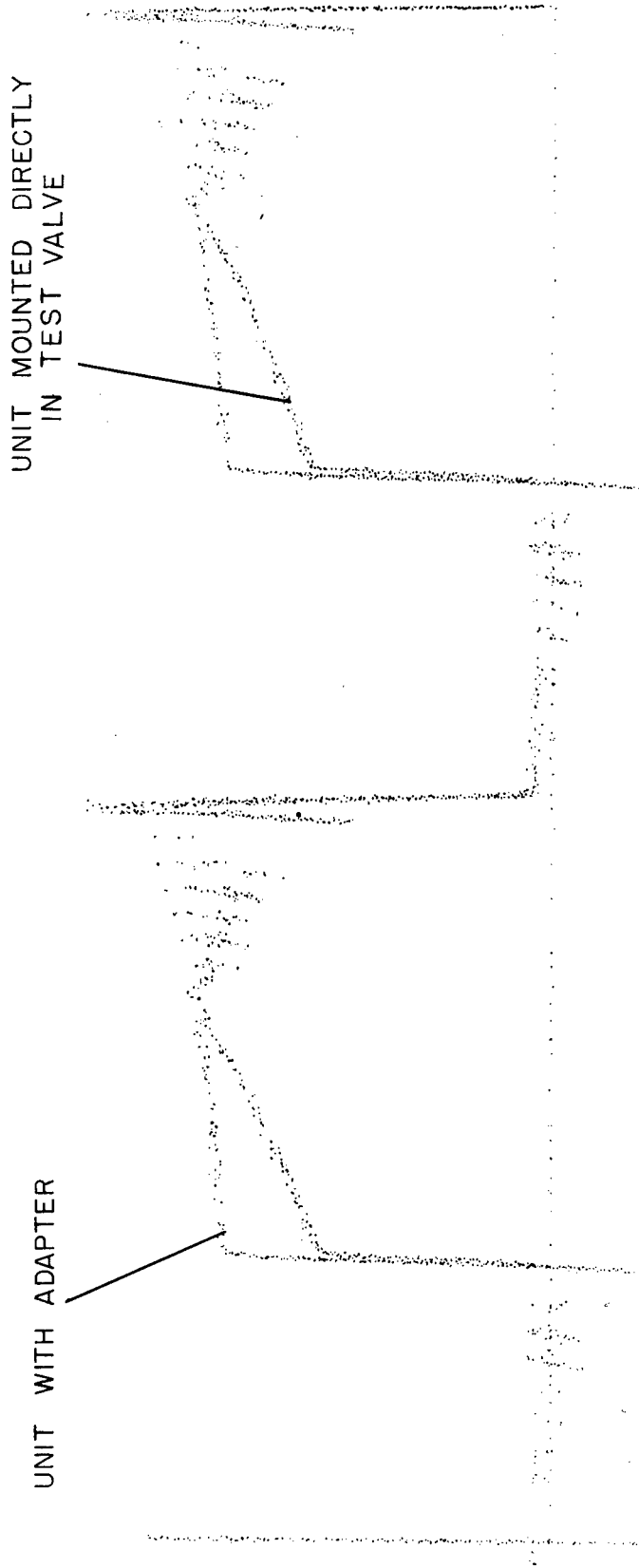

Figure 12.- Effect of connecting passage with small cross section. Valve speed, 900 rpm.

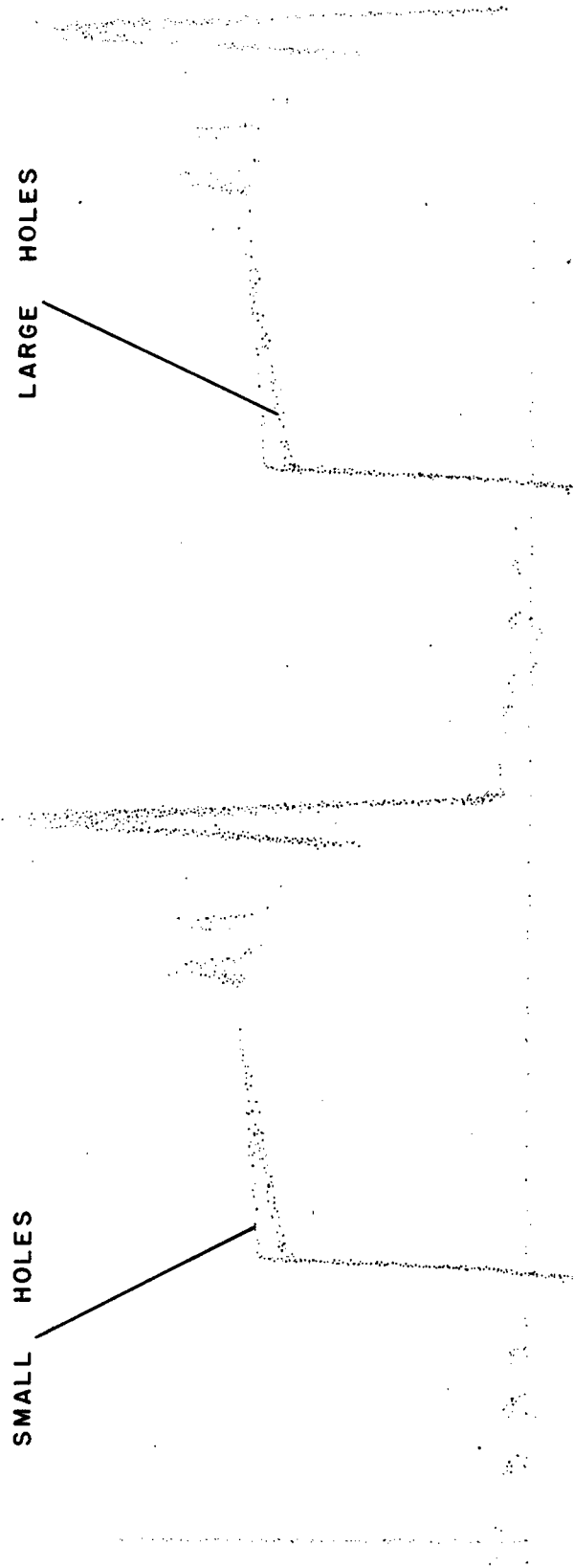

Figure 13.- Effect of backing plates. Valve speed, 1800 rpm.

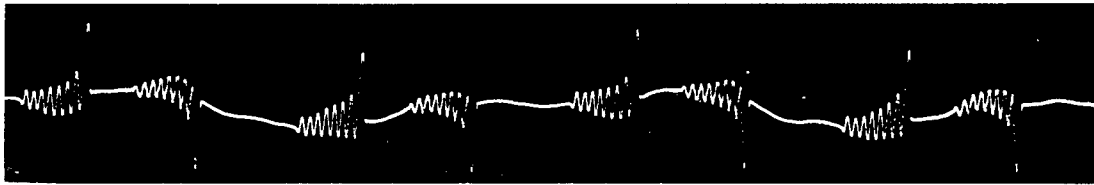

Figure 14.- Record from magnetic pickup of rate of pressure change against time.

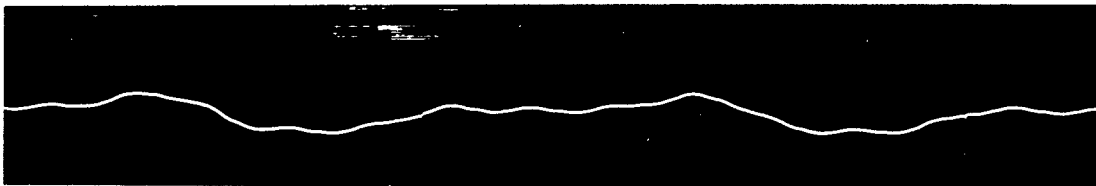

Figure 15.- Response of magnetic pickup to stray field effects of valve disk.

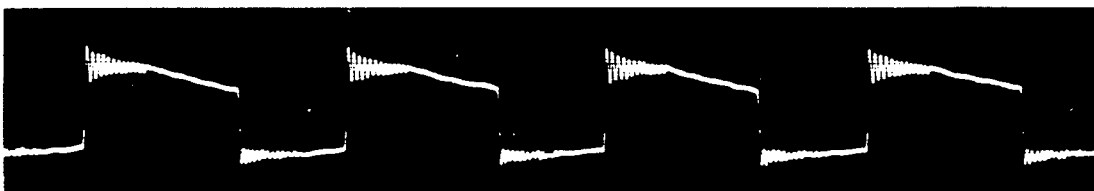
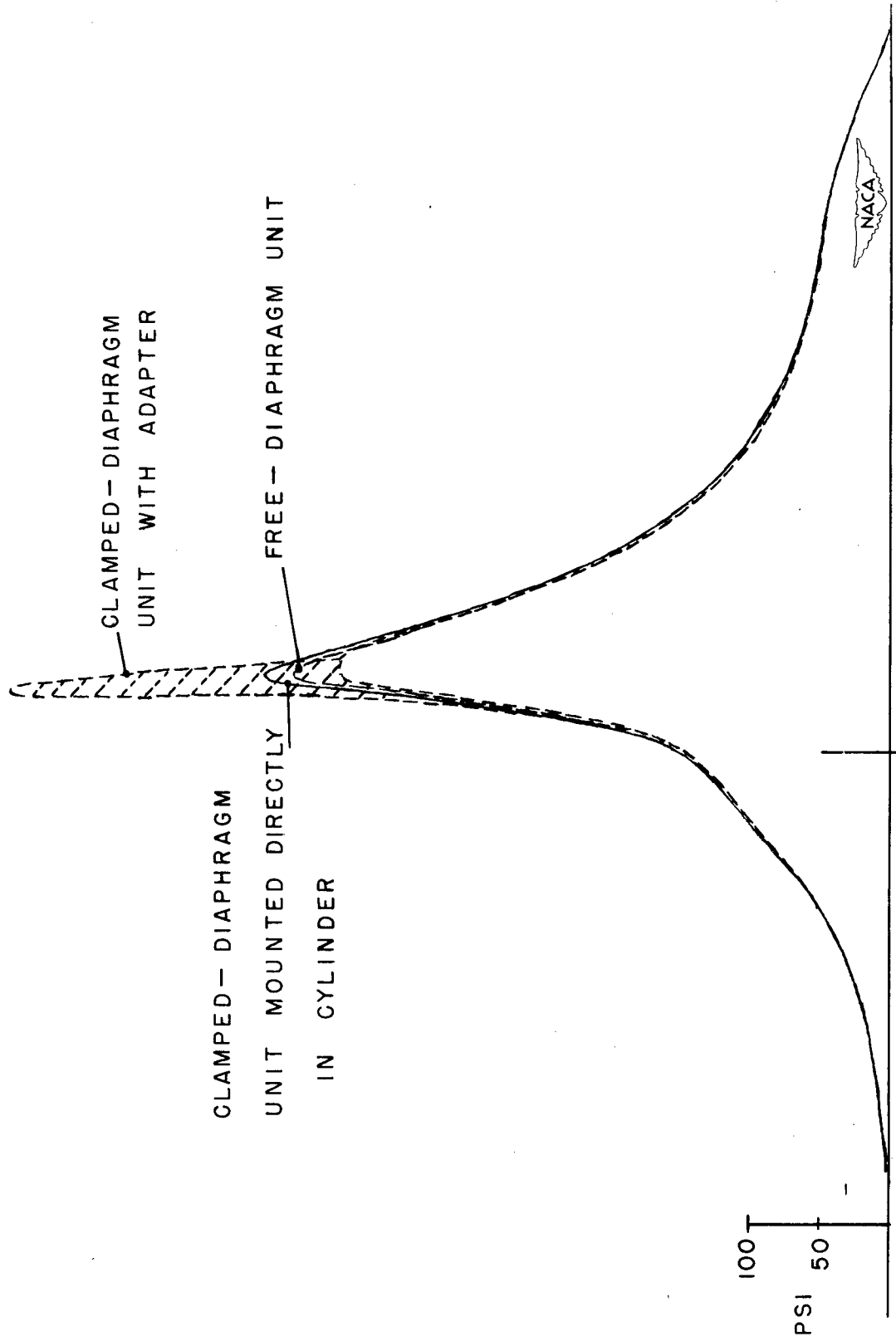
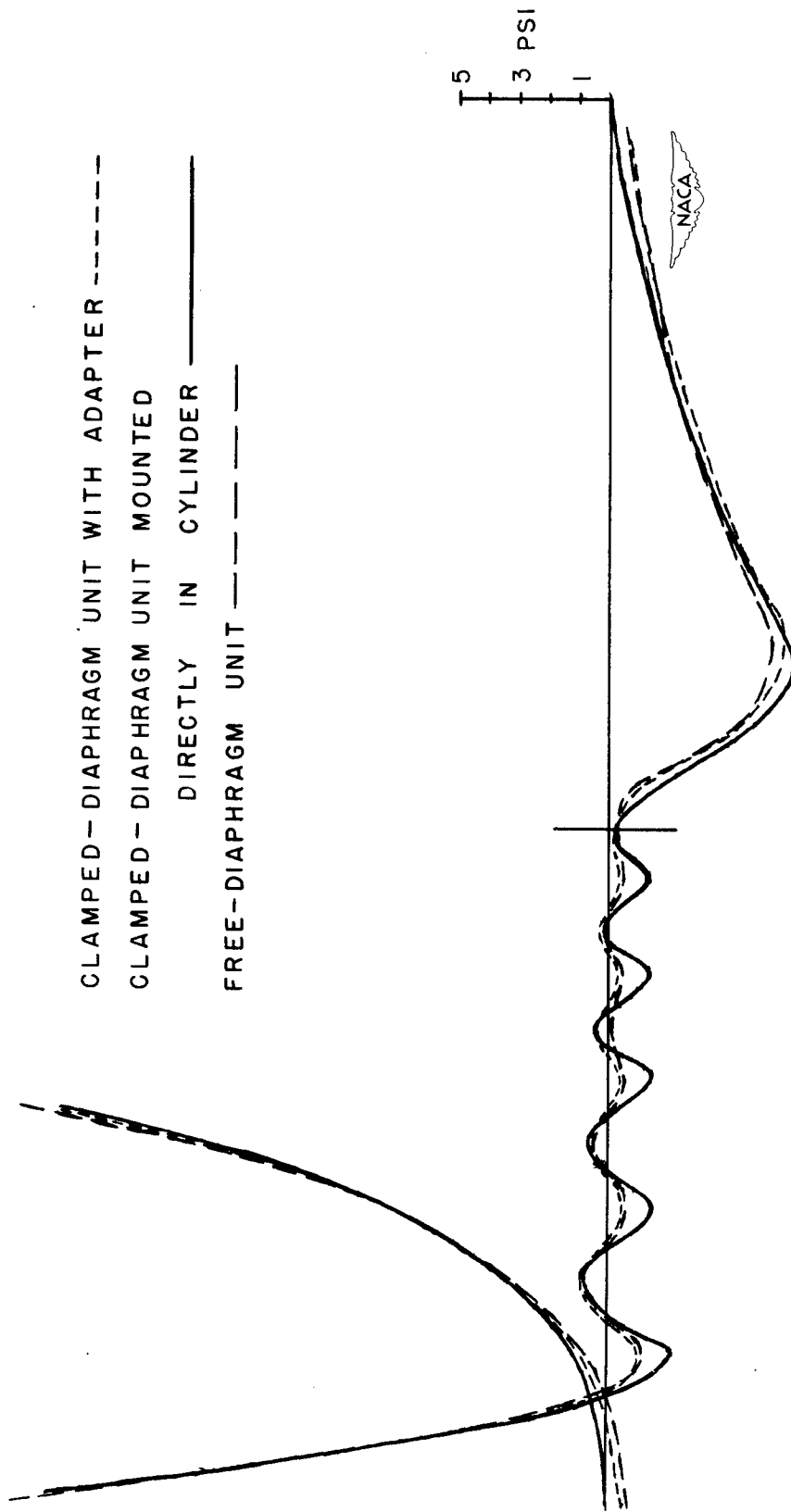

Figure 16.- Record from a piezoelectric pickup.



(a) High-pressure diagram.

Figure 17.- Records from a firing CFR engine.



(b) Low-pressure diagram.

Figure 17.- Concluded.

Charging and Control - Reciprocating Engines 3.2.1



Improvement of Accuracy of Balanced-Pressure Indicators and Development of an Indicator Calibrating Machine.

By James C. Livengood

NACA TN 1896

June 1949

(Abstract on Reverse Side)

Livengood, James C.



Improvement of Accuracy of Balanced-Pressure Indicators and Development of an Indicator Calibrating Machine.

By James C. Livengood

NACA TN 1896

June 1949

(Abstract on Reverse Side)

Research Equipment - Propulsion

9.1.4



Improvement of Accuracy of Balanced-Pressure Indicators and Development of an Indicator Calibrating Machine.

By James C. Livengood

NACA TN 1896

June 1949

(Abstract on Reverse Side)



Abstract

Tests and comparisons of clamped- and unclamped-diaphragm balanced-pressure indicators, electrical indicators, and a sampling-valve indicator are presented. The unclamped-diaphragm unit was found to give very satisfactory light-spring diagrams from a high-speed engine. A description is given of the square-pressure-wave calibrating valve.

Abstract

Tests and comparisons of clamped- and unclamped-diaphragm balanced-pressure indicators, electrical indicators, and a sampling-valve indicator are presented. The unclamped-diaphragm unit was found to give very satisfactory light-spring diagrams from a high-speed engine. A description is given of the square-pressure-wave calibrating valve.

Abstract

Tests and comparisons of clamped- and unclamped-diaphragm balanced-pressure indicators, electrical indicators, and a sampling-valve indicator are presented. The unclamped-diaphragm unit was found to give very satisfactory light-spring diagrams from a high-speed engine. A description is given of the square-pressure-wave calibrating valve.