

Jan  
10/12

NACA TN 1959

# NATIONAL ADVISORY COMMITTEE FOR AERONAUTICS

TECHNICAL NOTE 1959

GUST-TUNNEL INVESTIGATION OF A FLEXIBLE-WING MODEL  
WITH SEMICHORD LINE SWEPT BACK  $45^{\circ}$

By Thomas D. Reisert

Langley Aeronautical Laboratory  
Langley Air Force Base, Va.

**DISTRIBUTION STATEMENT A**  
Approved for Public Release  
Distribution Unlimited

Reproduced From  
Best Available Copy



Washington  
October 1949

20000801 132

DTIC QUALITY INSPECTED 4

AQ M 00-10-3327

NATIONAL ADVISORY COMMITTEE FOR AERONAUTICS

TECHNICAL NOTE 1959

GUST-TUNNEL INVESTIGATION OF A FLEXIBLE-WING MODEL

WITH SEMICHORD LINE SWEEP BACK  $45^\circ$

By Thomas D. Reisert

SUMMARY

An investigation was made in the Langley gust tunnel of a flexible-wing model with the semichord line swept back  $45^\circ$  to obtain experimental data on the amount of gust-load alleviation that might be expected as a result of the wings flexing under load. The results indicated that unless adverse pitching motion could be eliminated or reduced the overall load reduction would be small. The net reduction in bending moment, however, may be appreciable.

INTRODUCTION

Investigations made on sweptforward and sweptback rigid-wing models have indicated that the gust loads are less than for those of an equivalent straight wing (reference 1). The effects of elastic deformation of swept wings are now of interest in relation to gust alleviation. For a sweptback wing, bending of the wing panel offers a possibility of load alleviation since the local angle of attack of the wing is reduced. Bending deflections of a sweptforward wing, on the other hand, would then lead to increased loads. Inasmuch as bending deflections of sweptback wings are a possible means of gust alleviation, a preliminary investigation was made in the Langley gust tunnel to obtain experimental data on the amount of alleviation that might be expected for a representative sweptback-wing configuration.

The present paper gives the results of tests of a  $45^\circ$  sweptback-wing model with outer wing panels connected by means of spring hinges to the wing root. Accelerations and corresponding pitching motions of the model flown with the wings locked are compared with those for the wings free to deflect against a spring.

Preceding Page's Blank

## APPARATUS AND TESTS

The model used for the investigation was the  $45^\circ$  sweptback-wing model described in reference 1 modified by inserting hinges between the root section and the wing panels. A photograph of the model used in the tests is shown as figure 1, and the plan-view line drawing is shown in figure 2. The characteristics of the model and the test conditions are as follows:

Weight, W, pounds . . . . .	13.94
Wing area, S, square feet . . . . .	6.05
Wing loading, W/S, pounds per square foot . . . . .	2.30
Span, b, feet . . . . .	4.25
Aspect ratio, $b^2/S$ . . . . .	2.99
Chords measured parallel to plane of symmetry:	
Mean geometric chord, feet . . . . .	1.425
Root chord, $c_R$ , feet . . . . .	1.90
Tip chord, $c_t$ , feet . . . . .	0.95
Taper ratio, $c_t/c_R$ . . . . .	0.5
Slope of lift curve determined by force tests, per radian (reference 1) . . . . .	
Center-of-gravity position, percent of mean geometric chord . . .	31.07
Gust velocity, U, feet per second . . . . .	10.0
Forward velocity, V, miles per hour . . . . .	60.0

The wing hinges placed perpendicular to the 50-percent-chord line, as shown in figure 2, were restrained by torsion springs that allowed the panel to deflect in bending but not in twist. The outer panels were stiffened internally so that all deflection took place at the hinge. The hinge characteristics were such that a wing-tip deflection of 1.25 inches per g of acceleration was obtained corresponding to about 20 inches per g on a transport airplane of 100-foot span. The wing natural frequency about the hinge was about 8 cycles per second or 2 cycles per second for the corresponding full-scale airplane.

The present Langley gust tunnel is the same in principle as the gust tunnel described in reference 2 and utilizes like instrumentation and techniques. The capacity of the gust-tunnel equipment now used is such that 6-foot-span models can be flown up to speeds of 100 miles per hour through gusts with velocities up to 20 feet per second. The gust or jet of air provided is 8 feet wide and 14 feet long. The gust profile used in the tests is shown in figure 3 as the ratio of local gust velocity to the average maximum gust velocity plotted against the penetration in mean geometric chords of the model.

Tests of the hinged-wing model consisted of flights of the model at a forward speed of about 60 miles per hour through a sharp-edge gust

of about 10 feet per second with the wings locked in neutral position and then with the wings free to deflect or respond to the loads imposed by the gusts. A minimum of seven flights was made for each condition. Measurements of forward velocity, gust velocity, normal-acceleration increment (recorded acceleration minus acceleration in steady flight), and pitch-angle increment were made during each flight.

PRECISION

The measured quantities are estimated to be accurate within the following limits for any single test or single flight:

Acceleration increment, $\Delta n$ , g units . . . . .	$\pm 0.05$
Forward velocity, feet per second . . . . .	$\pm 0.5$
Gust velocity, feet per second . . . . .	$\pm 0.10$
Pitch-angle increment, $\Delta \theta$ , degrees . . . . .	$\pm 0.10$

Results from repeat flights should have a maximum error of not more than  $\pm 0.05g$  for a sharp-edge gust. Calculations indicate that the error should not exceed  $\pm 0.1g$  when the responses to the sharp-edge gust are built up to represent the responses to a gust with a gradient distance of 9 chords.

RESULTS

The records for all flights were evaluated to obtain histories of the normal-acceleration and pitch increments during the traverse of the gust. Representative histories of results for tests in a sharp-edge gust of the model with the wing panels locked and with them free to deflect are shown in figure 4(a).

Histories of events for the model penetrating a gust with a linear gradient distance of 9 chords were obtained by building up by superposition the histories obtained in the sharp-edge gust under the assumption that the gust profile of figure 3 can be considered to be a "unit-jump" type of gust (reference 3). Sample histories of responses to a gust with a linear gradient distance of 9 chords are shown in figure 4(b).

The maximum acceleration increment for each test flight was determined from the flight record and was corrected to a forward velocity of 60 miles per hour and a gust velocity of 10 feet per second on the basis of the assumption that the acceleration increment is directly proportional to forward speed and gust velocity. This

correction was made so that the effect of minor variations in launching speed and gust velocity can be eliminated. The corrected maximum acceleration increments for the flights made with the wing panels locked and for the flights with the wing panels free to deflect are presented in table I. The average of the corrected maximum acceleration increments is presented in table II.

### DISCUSSION

Comparison of the experimental values of  $\Delta n_{max}$  in table II indicates that, when the wings are free to deflect under load, reductions of 8 percent for the sharp-edge gust and 14 percent for the 9-chord gust are obtained. Simplified calculations, however, show that an ideal alleviation of about 25 percent could be expected if the wing panel is assumed to follow the application of load and if unsteady lift and pitch are neglected. The discrepancy between calculation and experiment was thought to be principally a result of pitching motion. Figure 4(a) shows that when the wings are free to deflect the pitching increment is almost double the value obtained with the wings locked and is in a direction which would increase the load.

In order to evaluate simply the effect of wing flexibility alone, the effect of pitching motion is removed from the value of  $\Delta n_{max}$  by subtracting the term

$$\Delta n_{\theta} = \frac{\rho m V^2 S}{114.6W} \int_0^{s_1} C_{L\alpha} (s_1 - s) \frac{d\theta}{ds} ds$$

so that

$$\Delta n_{max_0} = \Delta n_{max} - \Delta n_{\theta}$$

where

$\Delta n_{\theta}$	acceleration increment resulting from pitching motion of wing, g units
$\Delta n_{max}$	maximum acceleration increment, g units
$\rho$	mass density of air, slugs per cubic foot
$m$	slope of wing-lift curve, per radian
$V$	forward velocity, feet per second
$S$	wing area, square feet

W	weight of model, pounds
$\theta$	pitch angle of wing, degrees
s	distance penetrated into gust by foremost point of leading edge of wing, chords
$s_1$	distance penetrated into gust by foremost point of leading edge of wing at which acceleration increment is to be determined, chords
$C_{L\alpha}(s_1 - s)$	unsteady-lift function for a sudden change of angle of attack over entire wing expressed as a function of $s_1 - s$

Comparison of the values of  $\Delta n_{max_0}$  in table II for the two test conditions indicates that when the effect of pitch is removed the acceleration increment is reduced 20 percent by the wing deflecting under load. The increased pitching motion of the model when the wings are free can be explained on the basis that one of the characteristics common to sweptback wings is that, as the wing is deflected by a gust load, the local angle of attack of the tip is reduced which results in an inboard shift of the load center. This shift, in turn, causes a forward movement of the aerodynamic center which results in an additional pitching motion. Therefore, unless adverse pitching motion can be eliminated the gain in over-all load reduction will be small. An appreciable reduction of the wing bending moment occurs, however, since the outboard loads are reduced considerably.

Although no experimental investigation was made for sweptforward wings, in a gust the outboard loads on a flexible sweptforward wing could be expected to increase because of an increased angle of attack of the tip and this increase would result in a load increase. The change in spanwise load distribution would also result in a positive pitching motion as for the sweptback wing. For a  $45^\circ$  sweptforward wing, the load is therefore estimated to increase 20 percent as a result of the change in angle of attack of the outboard section and an additional 12 percent as a result of the pitching motion.

#### CONCLUDING REMARKS

The results of an investigation made of a flexible-wing model with the semichord line sweptback  $45^\circ$  indicated that wing flexibility resulted in an over-all reduction in gust load of approximately 8 percent for a sharp-edge gust and 14 percent for a 9-chord gradient gust. Elimination of the effects of pitching motion caused by a forward movement of the aerodynamic center when the wing was deflected, however,

indicated that the alleviation due to wing bending alone was approximately 20 percent. Therefore, unless adverse pitching motion can be eliminated or reduced, the gain in over-all load reduction will be small. The net reduction in bending moment, however, may be appreciable since the outboard loads are reduced considerably.

Langley Aeronautical Laboratory  
National Advisory Committee for Aeronautics  
Langley Air Force Base, Va., July 29, 1949

#### REFERENCES

1. Pierce, Harold B.: Tests of a  $45^\circ$  Sweptback-Wing Model in the Langley Gust Tunnel. NACA TN 1528, 1948.
2. Donely, Philip: An Experimental Investigation of the Normal Acceleration of an Airplane Model in a Gust. NACA TN 706, 1939.
3. Jones, Robert T.: Calculation of the Motion of an Airplane under the Influence of Irregular Disturbances. Jour. Aero. Sci., vol. 3, no. 12, Oct. 1936, pp. 419-425.

TABLE I  
VALUES OF CORRECTED MAXIMUM ACCELERATION INCREMENTS

Flight	$\Delta n_{\max}$ (g units)	
	Wings locked in zero position	Wing free to deflect
1	1.16	1.08
2	1.15	1.02
3	1.08	1.04
4	1.11	1.06
5	1.11	1.06
6	1.17	1.06
7	1.16	1.07
8	----	1.02
9	----	0.99

TABLE II  
COMPARISON OF AVERAGE CORRECTED MAXIMUM ACCELERATION INCREMENTS

Gradient distance (chords)	$\Delta n_{\max}$ (g units)		$\Delta n_{\max 0}$ ( $\Delta n_{\max}$ reduced to zero pitch) (g units)	
	Wings locked in zero position	Wings free to deflect	Wings locked in zero position	Wings free to deflect
0	1.13	1.04	1.00	0.80
9	.93	.80	.81	.64



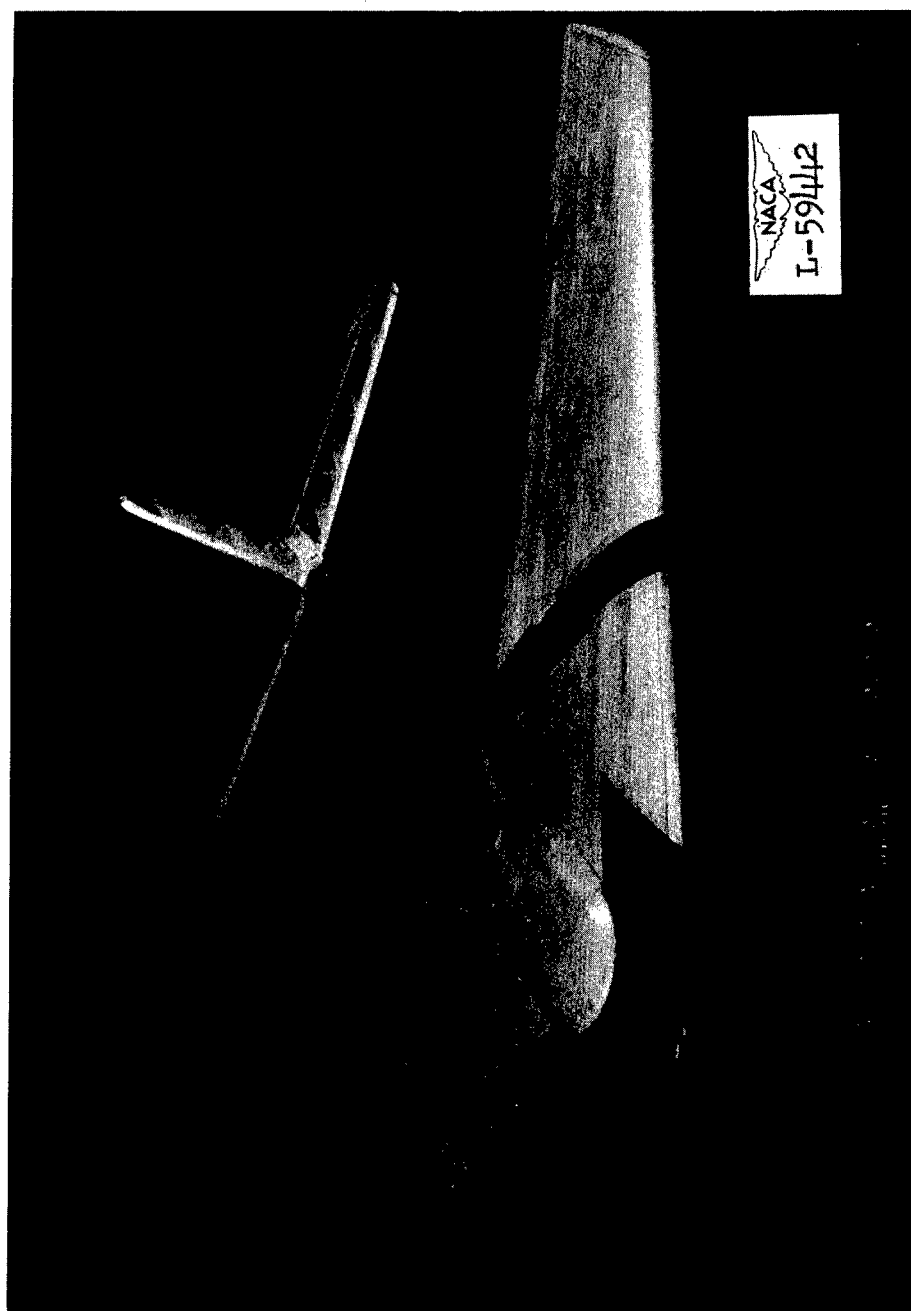

Figure 1.- Flexible-wing model with semichord line swept back  $45^\circ$ .

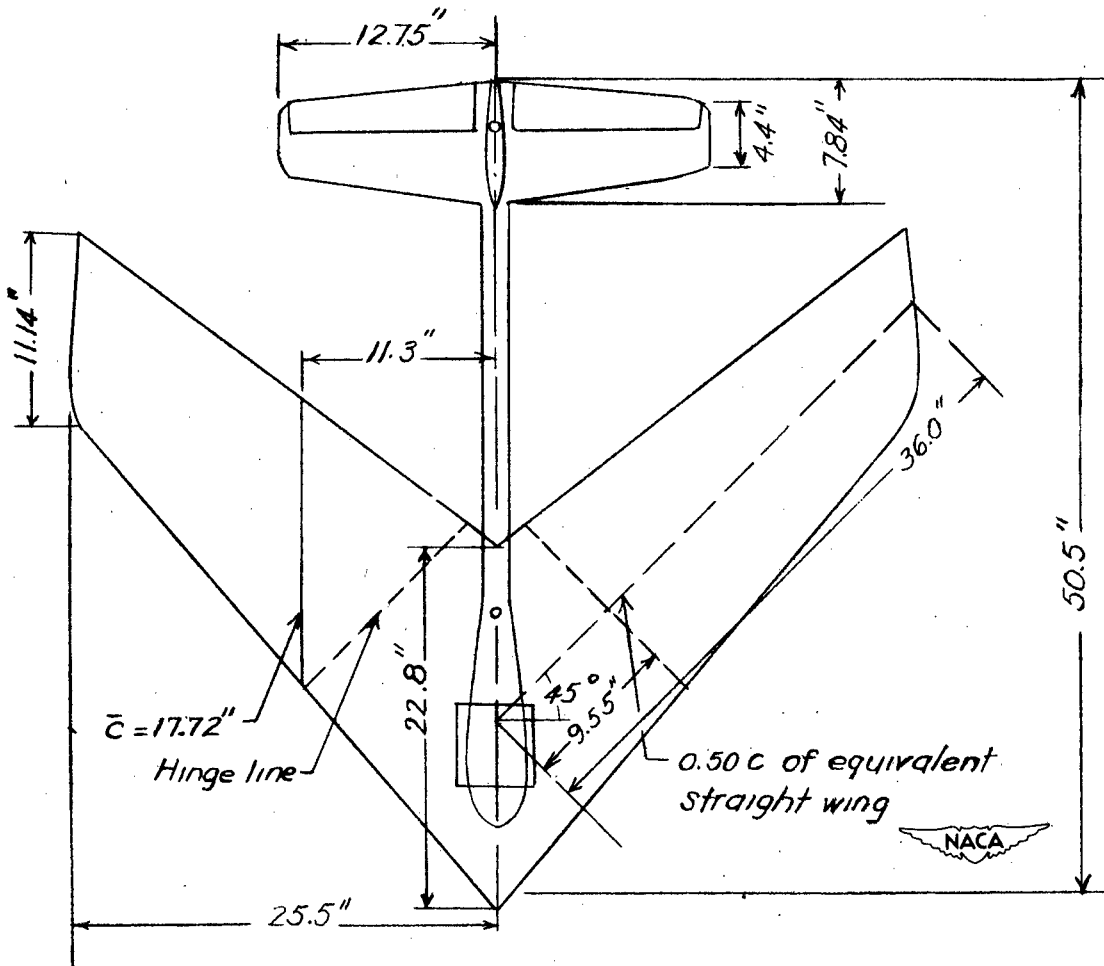

Figure 2.- Plan form of  $45^\circ$  sweptback wing model.

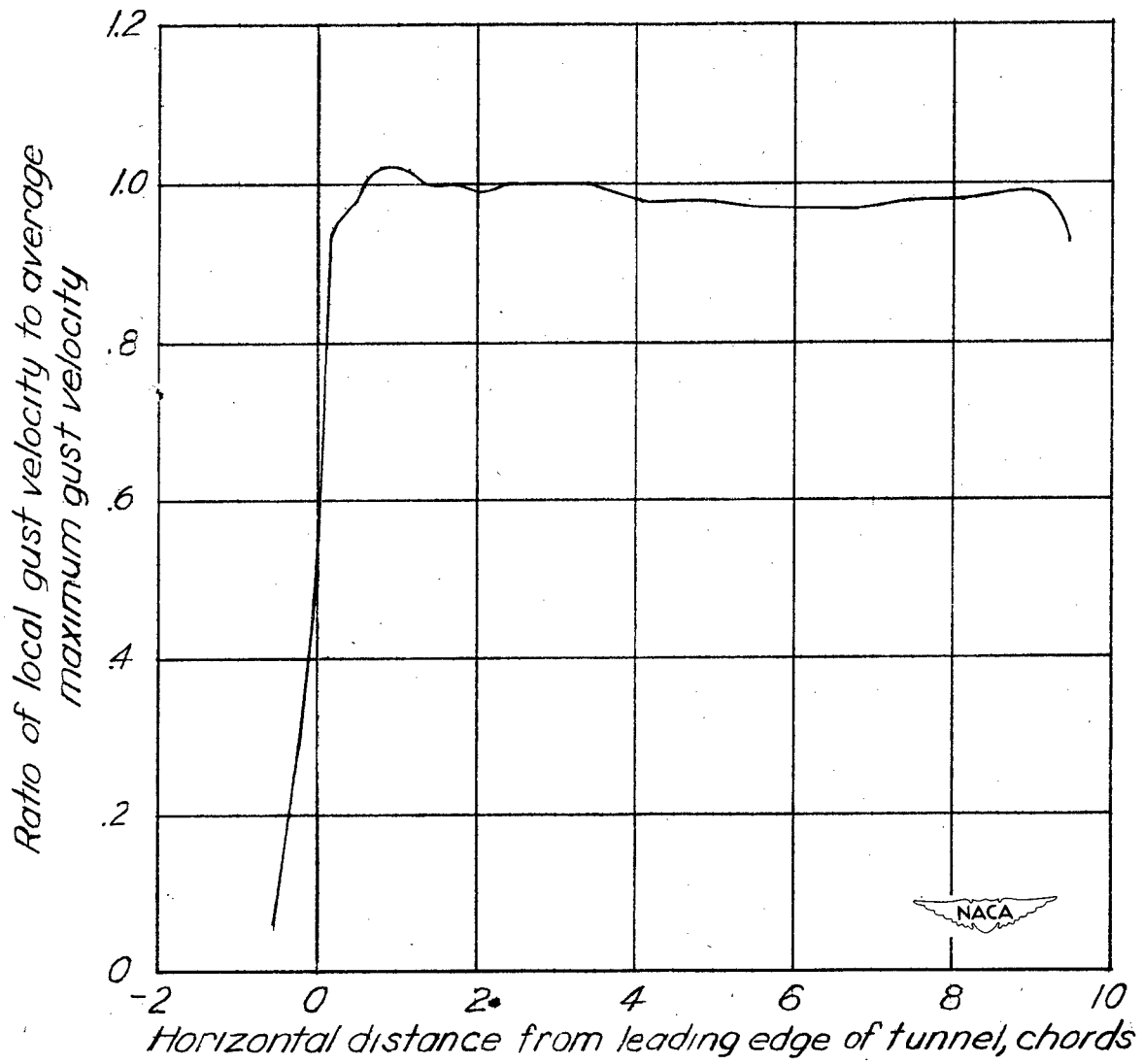
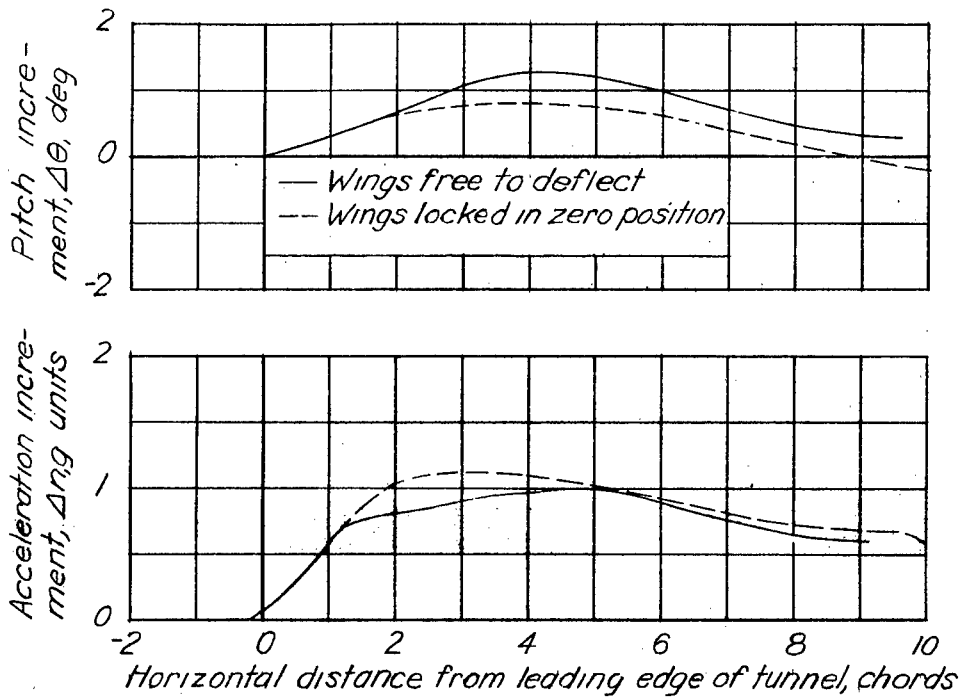
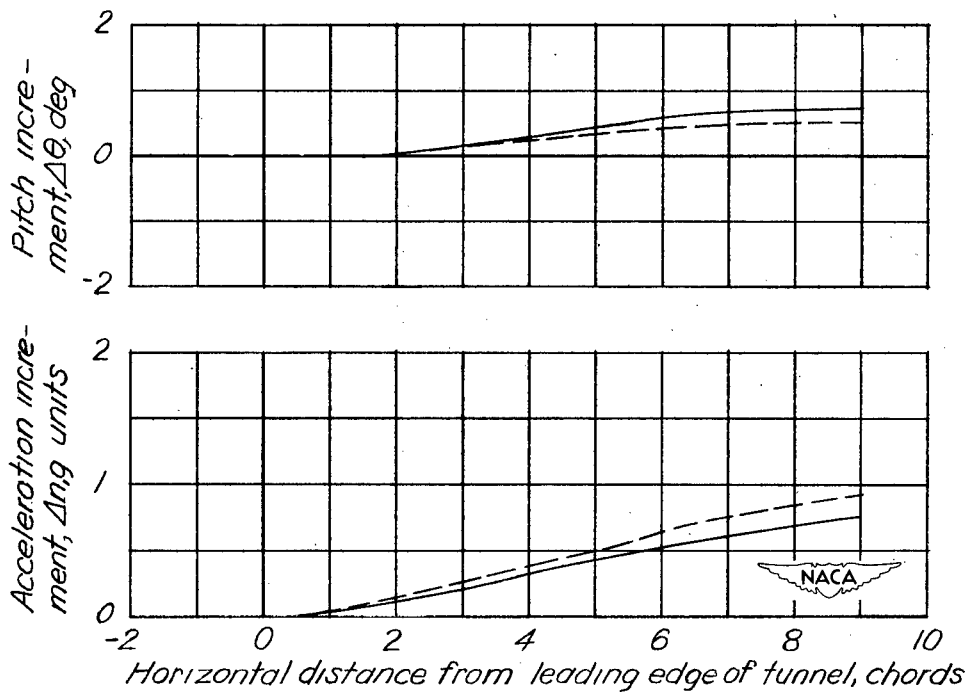

Figure 3.—Velocity distribution through jet.



(a) Sharp-edge gust



(b) Gust with 9-chord gradient distance. (Computed from experimental data for sharp-edge gust)

Figure 4.—Representative histories of events in test gusts.