

4425
17

NACA TN 2520

NATIONAL ADVISORY COMMITTEE FOR AERONAUTICS

TECHNICAL NOTE 2520

**EFFECTS OF PRESSURE-RAKE DESIGN PARAMETERS ON
STATIC-PRESSURE MEASUREMENT FOR RAKES USED
IN SUBSONIC FREE JETS**

By Lloyd N. Krause

Lewis Flight Propulsion Laboratory
Cleveland, Ohio

**Reproduced From
Best Available Copy**



Washington
October 1951

DISTRIBUTION STATEMENT A
Approved for Public Release
Distribution Unlimited

20000731 163

DTIC QUALITY INSPECTED 4

AQ M00-10-3255

1

NATIONAL ADVISORY COMMITTEE FOR AERONAUTICS

TECHNICAL NOTE 2520

EFFECTS OF PRESSURE-RAKE DESIGN PARAMETERS ON STATIC-PRESSURE
MEASUREMENT FOR RAKES USED IN SUBSONIC FREE JETS

By Lloyd N. Krause

SUMMARY

2273

A subsonic-free-jet investigation was conducted to determine the effect of pressure-rake design parameters on static-pressure measurement. The design parameters investigated include the location of the static orifices in relation to the tube nose and supporting strut, the proximity effects of adjacent tubes near the static orifices, and the effect of the ratio of support diameter to jet diameter. The investigation covered a Mach number range of 0.3 to 0.95.

Results of the investigation revealed that the effect of variation in the distance from the leading edge of the static-pressure tube to the static orifices was small compared with the effect of variation of the distance from the static orifices to the supporting strut. The effect of variation in the ratio of support diameter to jet diameter became pronounced at high velocities. Proximity effects of adjacent tubes near static-pressure tubes may be alleviated by proper orientation of the leading edge of the adjacent tube in relation to the static orifices.

Information and recommendations are provided for the design of pressure rakes to be used in subsonic free jets.

INTRODUCTION

As shown by many investigators, the accurate measurement of static pressure by the conventional tube depends upon the configuration chosen; that is, the proper location of the static orifices in relation to the nose and the support of the tube (for example, reference 1). These investigations were limited, however, to single tubes. Pressure rakes require considerable change in configuration from the basic tube design, which results in additional error in the static-pressure portion of the rake. The extent of this error depends mainly upon the five design parameters shown in figure 1. These parameters are: (1) the distance from the static orifices to the leading edge of the static-pressure

tube, (2) the distance from the static orifices to the support, (3) the distance between adjacent and static-pressure tubes, (4) the distance from the static orifices to the leading edge of the adjacent tubes, and (5) the ratio of support diameter to jet diameter.

In order to design rakes having minimum error and also to predict the magnitude of errors to be expected, the effects of each of the five parameters on static-pressure measurement were studied at the NACA Lewis laboratory.

The experiments covered a Mach number range of 0.3 to 0.95 at zero angle of attack. One representative rake configuration was also investigated over a Reynolds number range of 2×10^4 to 9×10^4 , which was based on the support diameter.

SYMBOLS

The following symbols are used in this report:

C_p	pressure coefficient ($\Delta p/q_c$)
d	diameter
M	free-stream Mach number
P	stream total pressure
p	stream static pressure
p'	static pressure indicated by static orifices of rake
Δp	static pressure error ($p' - p$)
q_c	impact pressure, difference between total pressure and static pressure ($P - p$)
X, Y	rake parameters as given in figure 1
Subscripts:	
j	jet
n	static pressure tube or adjacent tube, or both
s	support
t	distance from static orifices to leading edge of adjacent tubes

APPARATUS AND PROCEDURE

2273

A sketch of the pressure rake is shown in figure 1. The static-pressure tube consisted of cylindrical tubing with a hemispherical nose. Four static orifices were located on the tube 90° apart. Hemispherically nosed rods of the same diameter as the static-pressure tube were used to simulate the adjacent tubes and were located symmetrically on either side of the static-pressure tube. The support strut consisted of a cylindrical rod. Four different support diameters and two jet sizes ($3\frac{1}{2}$ -in. and 6-in. diam) were used to determine the effect of the ratio of support diameter to jet diameter.

The static pressure in the working region of the jets (0.5 to 1 jet diam downstream of the exit of the nozzle) remained very nearly ambient as determined by a calibration of the jets. This calibration was obtained with a 1/8-inch-diameter static-pressure search tube that extended from the stagnation chamber to a considerable distance downstream of the working region. The tube indicated that the static pressure in the working region was equal to ambient pressure to within 1 percent of the impact pressure q_c over the entire Mach number range.

The total pressure was equal to stagnation-tank pressure as determined by a total-pressure tube in the working region.

Air at random moisture content was used throughout the investigation. The effect of moisture on the results may be assumed to be small because the jets were free from measurable total-pressure loss.

Reynolds number effects were obtained by use of a jet in which the receiver pressure could be controlled.

RESULTS AND DISCUSSION

The geometry of the ideal rake configuration is such that its pressure coefficient will be zero at all Mach numbers and disturb the air flow as little as possible (that is, minimum frontal area). Because such a design is impossible in practice, a configuration with a minimum pressure coefficient is desired and the rake geometry should be such that the rate of change of pressure coefficient with Mach number is small.

The results of the rake-configuration investigation are shown in figures 2 to 8. In presenting the results, no attempt was made to isolate completely the effects of each parameter but rather to vary the value of a given parameter over the range normally encountered while the other parameters are held fixed at a nominal value. The effects of a given parameter are therefore analyzed as a change in pressure coefficient for a corresponding change in the value of the parameter.

Effect of nose of static-pressure tube. - The pressure indicated by static orifices located immediately behind the nose will be appreciably less than free-stream pressure because of the local acceleration created by the nose of the static-pressure tube. As the static orifices are moved downstream of the nose, the indicated pressure approaches the free-stream value. The effect on pressure coefficient of varying the distance from the static orifices to the leading edge of the static-pressure tube X_n from 3 to 7 diameters is shown in figure 2. The positive pressure coefficient at a free-stream Mach number of 0.9 is associated with shock due to flow over the nose. The pressure coefficient changes less than 1 percent for a variation in X_n from 3 to 7 diameters. Similar results are presented in reference 1. The remaining results are presented for X_n fixed at 5 diameters because the effect of the nose is small for values of X_n greater than 3.

Effect of support. - In rake design, a large source of error results from the location of the static orifices in relation to the support strut. This error occurs because of the stagnation region that exists at the front of the support.

The variation in pressure coefficient with Mach number for various distances of the static orifices from the support for a fixed ratio of support diameter to jet diameter is shown in figure 3. The distance from the static orifices to the support strut is expressed in terms of support diameters. For values of X_s less than 6 diameters, the slope of the pressure-coefficient Mach number curve becomes pronounced at high velocities. The resulting high pressure coefficient can be alleviated by reducing the radius of curvature at the leading edge of the support. The manner in which the pressure coefficient varies with parameter X_s at various Mach numbers is shown in figure 4. Again, a steep slope of the pressure-coefficient curve occurs for small values of X_s .

Changing the ratio of static-pressure-tube diameter to support diameter d_n/d_s over a range of d_n/d_s from 0.4 to 1.0 caused no change in the pressure coefficient.

Effect of ratio of support diameter to jet diameter. - A static-pressure sensing device when placed in an open jet will indicate a lower pressure than it would when placed in an infinite stream. The magnitude of this jet-boundary effect for the rake configuration investigated is shown in figure 5. The ordinate is expressed as the difference between the pressure coefficient indicated by the rake when placed in a free jet and that of an infinite stream, and the abscissa as the ratio of support diameter to jet diameter d_s/d_j . Figure 5 was obtained by linearly extrapolating the curves of figure 6 to zero support diameter and using that value of the pressure coefficient as the pressure coefficient of the configuration when placed in an infinite stream.

Over the range of d_s/d_j investigated in figure 5, the difference in the pressure coefficient for the free jet and the infinite stream varies linearly with d_s/d_j , the slope being nearly independent of X_s for a constant Mach number. The rate of change of the difference in pressure coefficient with d_s/d_j is small at low Mach numbers and becomes quite pronounced at the high velocities.

When water-cooled rakes are used at the exit of a jet engine, d_s/d_j is of the order of 0.03. For this value of d_s/d_j in figure 5, the jet boundary effects change the pressure coefficient from the infinite stream value by $7\frac{1}{2}$ percent at a Mach number of 0.9.

The results presented here are for rakes placed in an open jet. For closed ducts, the boundary effects are of opposite sign and of different magnitude depending on configuration. NOTE

In order to determine the effect of the Reynolds number, a configuration such as that of figure 6(a) with $d_s/d_j = 0.045$ was tested at several densities at a Mach number of 0.9. A variation in the Reynolds number, based on support diameter, from 2×10^4 to 9×10^4 changed the pressure coefficient less than 1 percent.

Tube proximity. - In many rake applications, large gradients necessitate placing total-pressure tubes, thermocouples, or other devices near static-pressure tubes on the same rake. It is important to know the extent to which the adjacent tubes influence the pressure coefficient.

The magnitude of the proximity effect for values of X_t of 1 diameter downstream and 1 diameter upstream of the static orifices is shown in figures 7(a) and 7(b), respectively. The adjacent tube induces a positive pressure coefficient when the leading edge is located downstream of the static orifices and a negative coefficient when upstream of the static orifices. The effect of variation in parameters X_t and Y at constant Mach number is shown more clearly in figure 8. The important feature of the curves is that the effect of variation in the Y -parameter becomes negligible for values of Y greater than 5 diameters. Also, for values of Y less than 5, the effect of variation in Y is negligible when $X_t = 0$; that is, when the leading edge of the adjacent tube is in line with the static orifices.

The results obtained with blunt-nosed adjacent tubes were of the same order of magnitude as the results for hemispherically nosed tubes.

Rake selection. - The choice of an optimum configuration which would satisfy any test condition desired is impractical because of the restrictions that many installations impose. However, certain recommendations can be stated as a guide to the choice of a rake configuration.

A value for the distance from the static orifices to the leading edge of the static-pressure tube greater than 3 diameters is recommended because the change in pressure coefficient for values greater than 3 diameters is small.

The choice of a value for the distance from the static orifices to support depends primarily upon tube strength considerations. It is desirable that the distance from the static orifices to support be at least greater than 6 support diameters. For values less than 6 diameters, the slope of the pressure-coefficient Mach number curve becomes steep at the high Mach numbers and an accurate estimate of the pressure coefficient becomes difficult. A value of 10 diameters or greater is preferable.

It is desirable to minimize the ratio of support diameter to jet diameter in order to obtain a pressure coefficient close to the infinite stream value.

If the ratio of support diameter to jet diameter and the distance from the static orifices to the support are known, figures 3 and 5 may be used to estimate the value of the pressure coefficient.

In considering the proximity effects of adjacent tubes near the static-pressure tubes, it is recommended that the tubes be 5 diameters or more apart. For cases where the tubes are less than 5 diameters apart, the leading edge of the adjacent tubes should be in line with the static orifices to minimize the proximity effects on pressure coefficient.

SUMMARY OF RESULTS

The following results were obtained in a subsonic-free-jet investigation conducted to determine the effect of pressure-rake design parameters on static-pressure measurement over a range of Mach numbers from 0.3 to 0.95:

1. The effect of variation in the distance from the leading edge of the static-pressure tube to the static orifices was small compared with the effect of the distance from the static orifices to the supporting strut.
2. The effect of variation in the ratio of support diameter to jet diameter became pronounced at high Mach numbers.

3. Proximity effects of adjacent tubes near static-pressure tubes may be alleviated by proper orientation of the leading edge of the adjacent tube in relation to the static orifices.

Lewis Flight Propulsion Laboratory
National Advisory Committee for Aeronautics
Cleveland, Ohio, July 31, 1951

REFERENCE

1. Huston, Wilber B.: Accuracy of Airspeed Measurements and Flight Calibration Procedures. NACA Rep. 919, 1948. (Formerly NACA TN 1605.)

2273

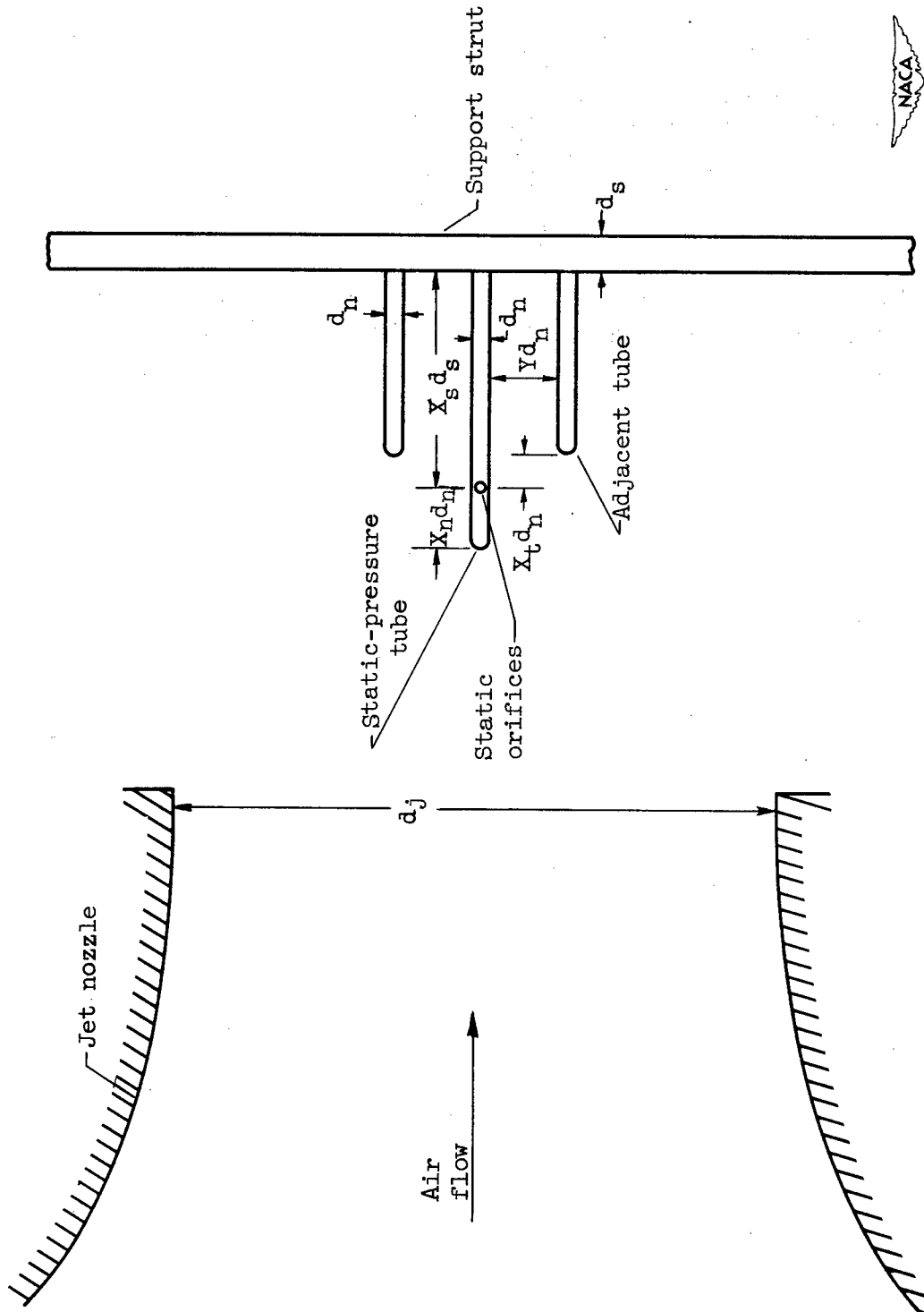

Figure 1. - Arrangement of pressure rake with respect to free jet showing rake components and design parameters.

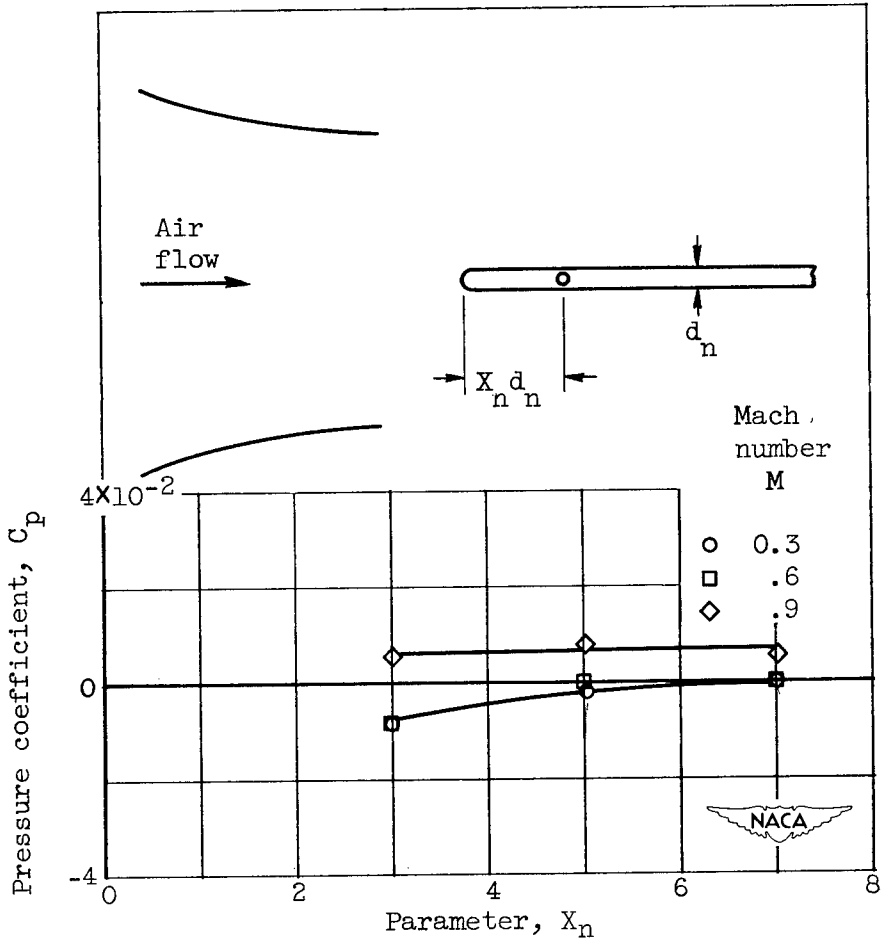

Figure 2. - Variation of pressure coefficient with distance from static orifices to leading edge of static-pressure tube.

2273

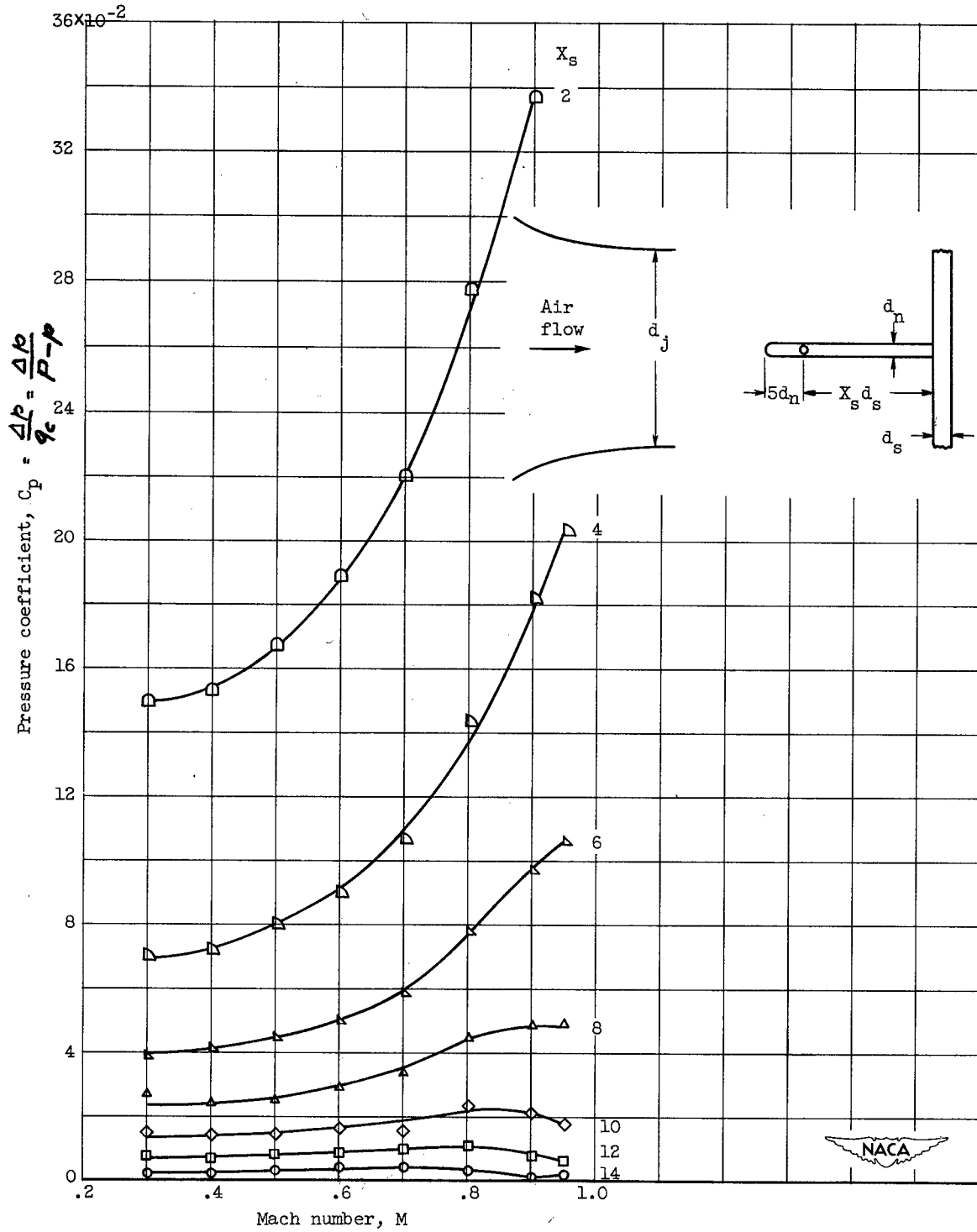

Figure 3. - Variation of pressure coefficient with Mach number for support at distance $X_s d_s$ behind static orifices; $d_n/d_s, 0.5$; $d_s/d_j, 0.036$.



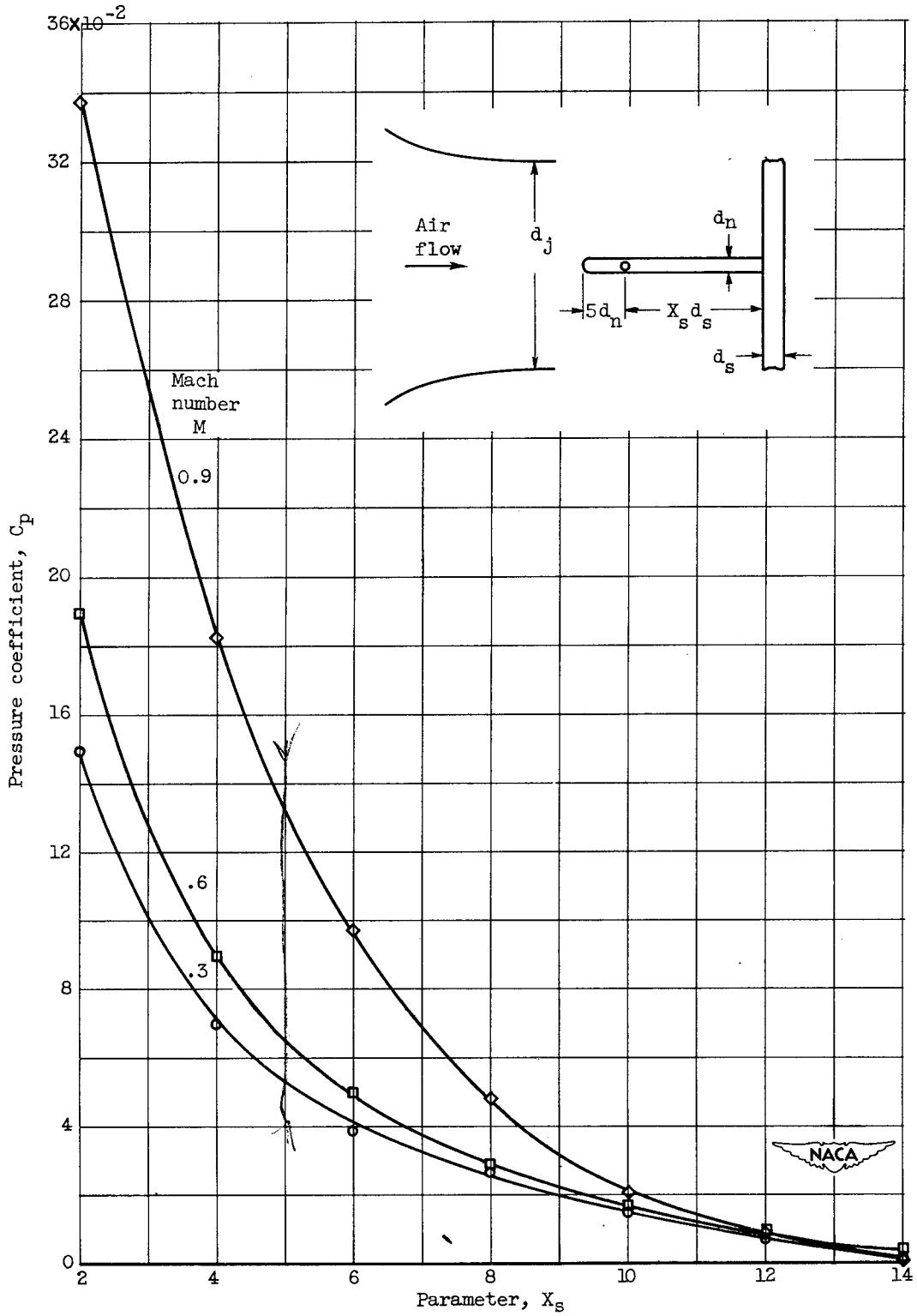

Figure 4. - Variation of pressure coefficient with distance from static orifices to support; $d_n/d_s, 0.5$; $d_s/d_j, 0.036$.

2273

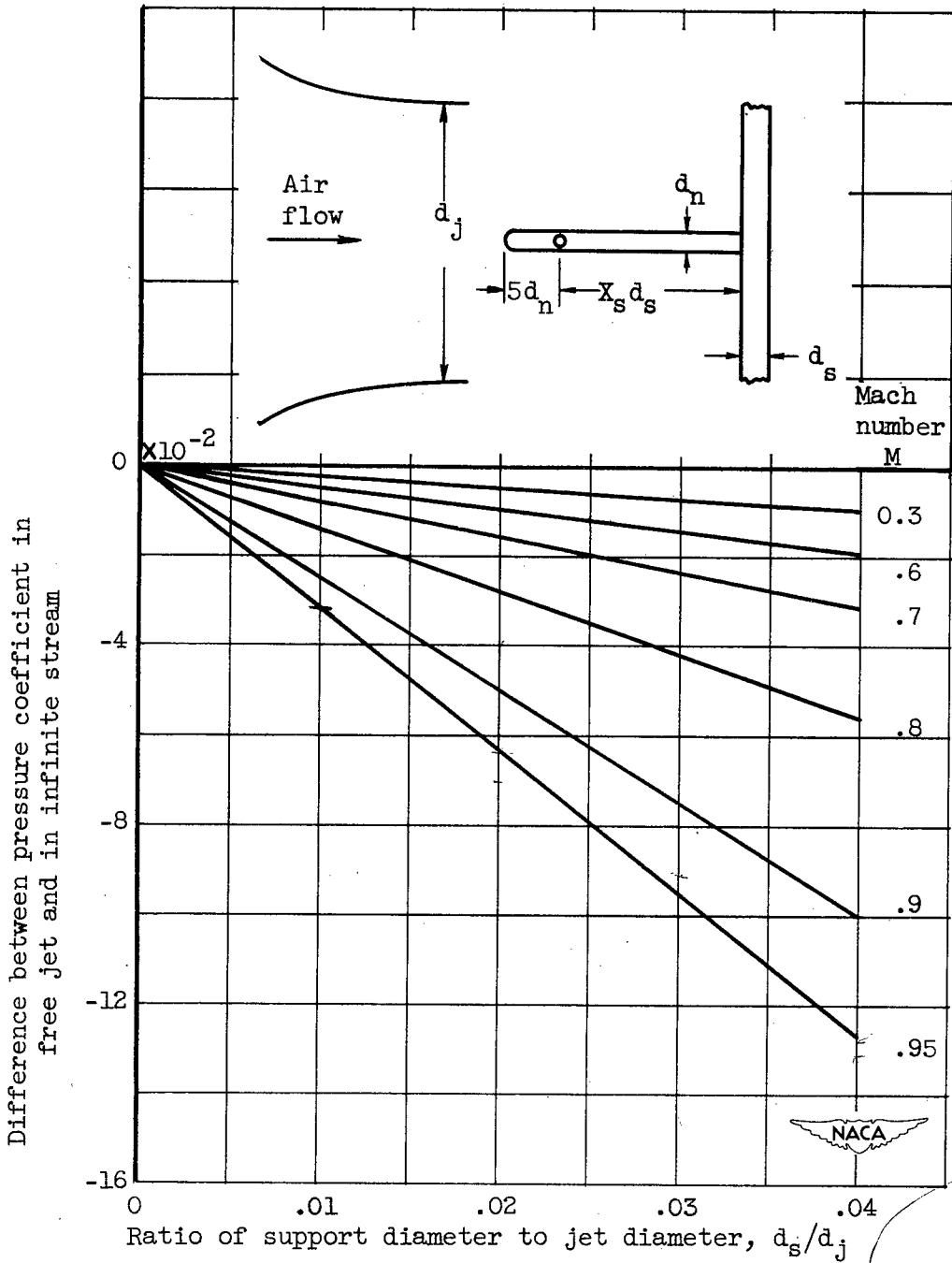
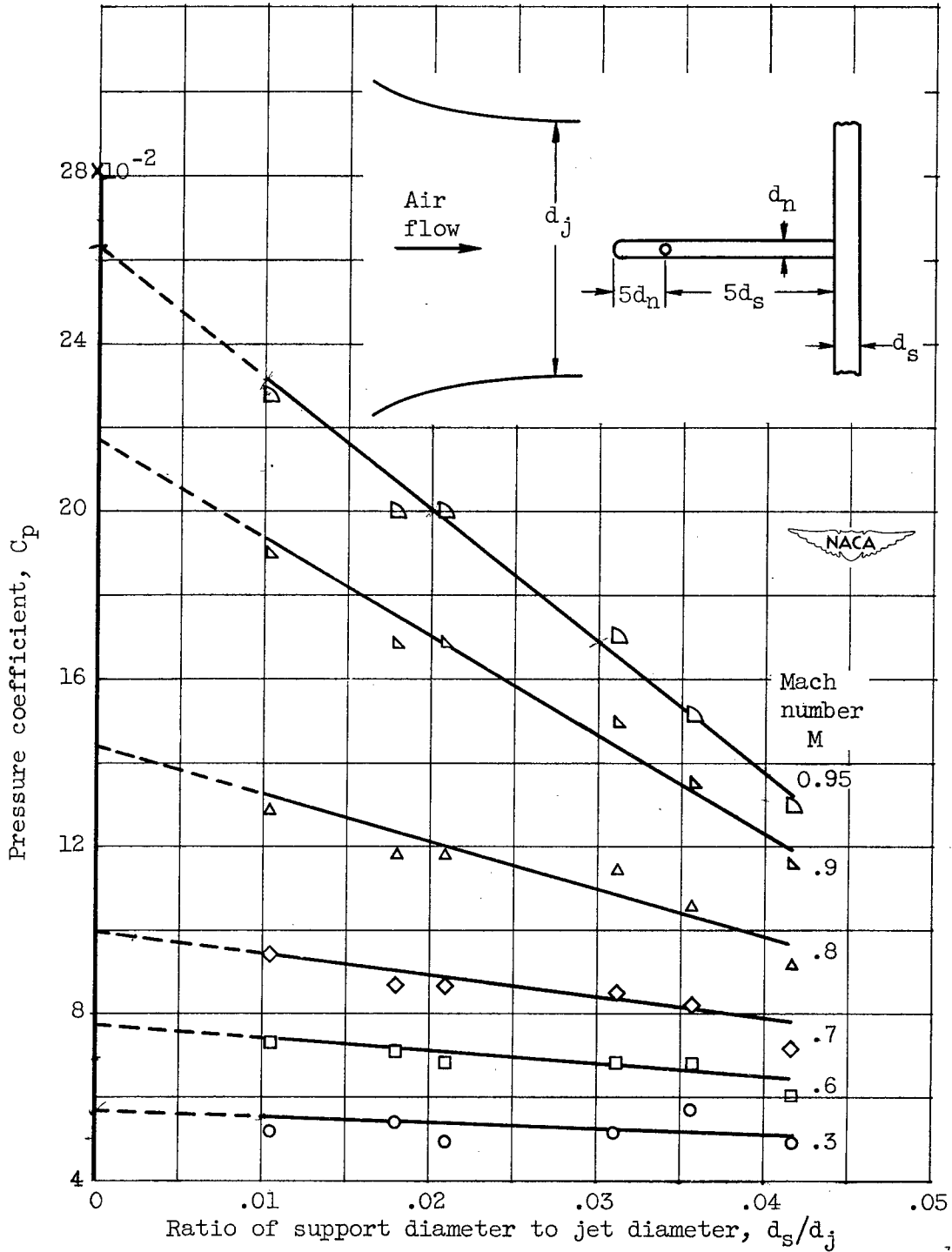

Figure 5. - Variation of difference between pressure coefficient in free jet and in infinite stream with ratio of support diameter to jet diameter; d_n/d_s , 0.5; X_s , 5 to 10.



2273



(a) Parameter, $X_s = 5$.

Figure 6. - Variation of pressure coefficient with ratio of support diameter to jet diameter; $d_n/d_s, 0.5$.

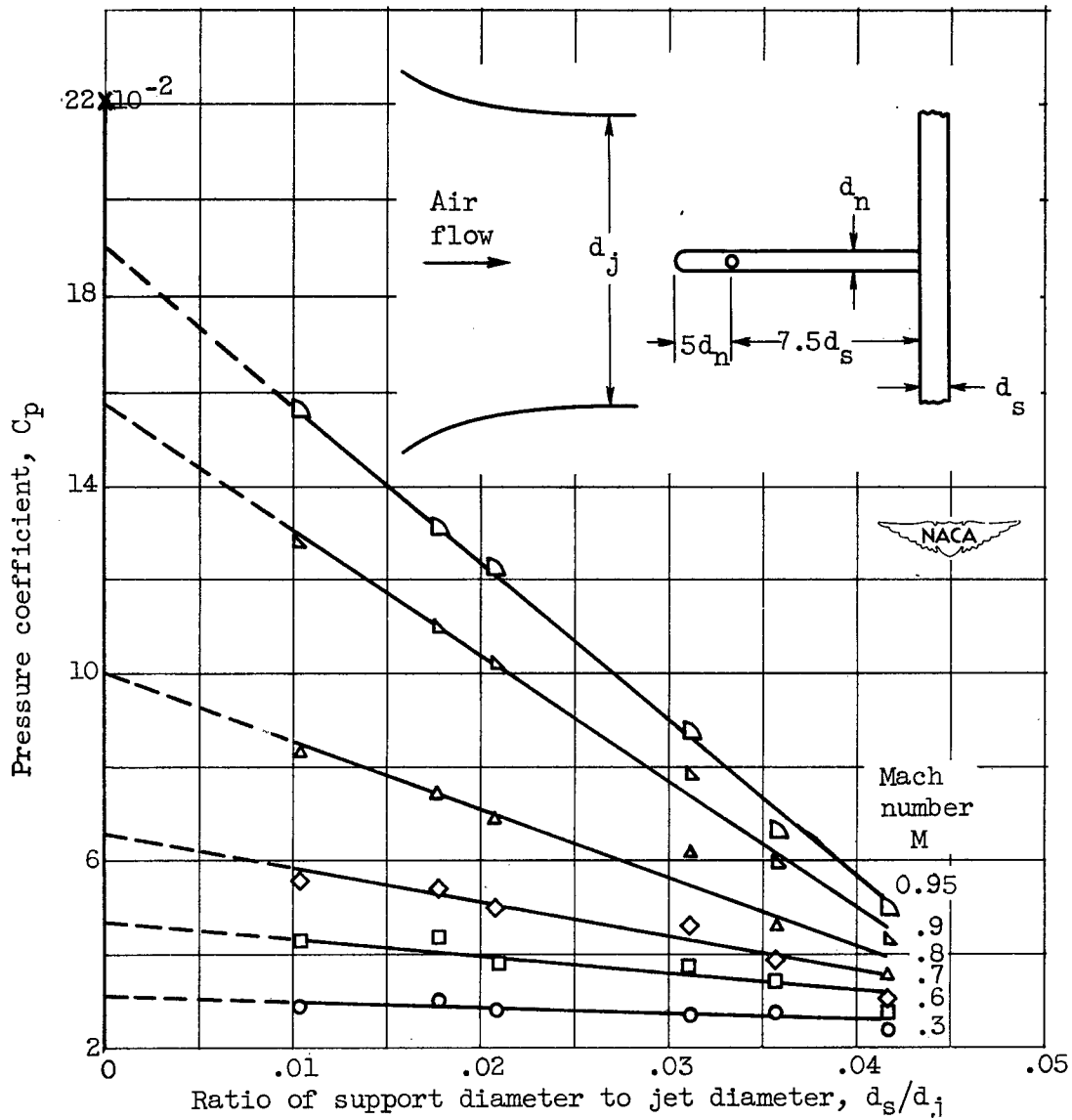

(b) Parameter, $X_s = 7.5$.

Figure 6. - Continued. Variation of pressure coefficient with ratio of support diameter to jet diameter; d_n/d_s , 0.5.

2273

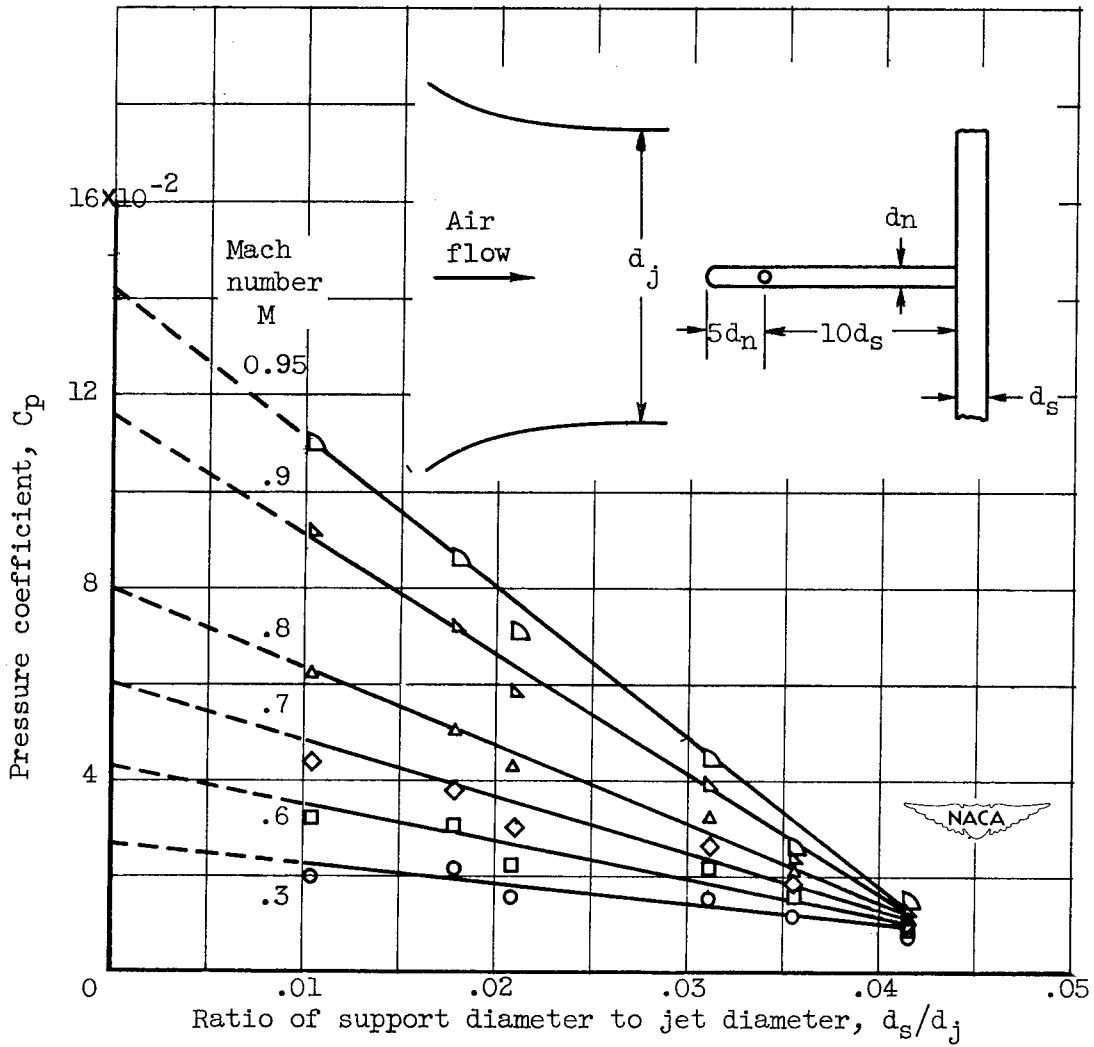

(c) Parameter, $X_s = 10$.

Figure 6. - Concluded. Variation of pressure coefficient with ratio of support diameter to jet diameter; d_n/d_s , 0.5.

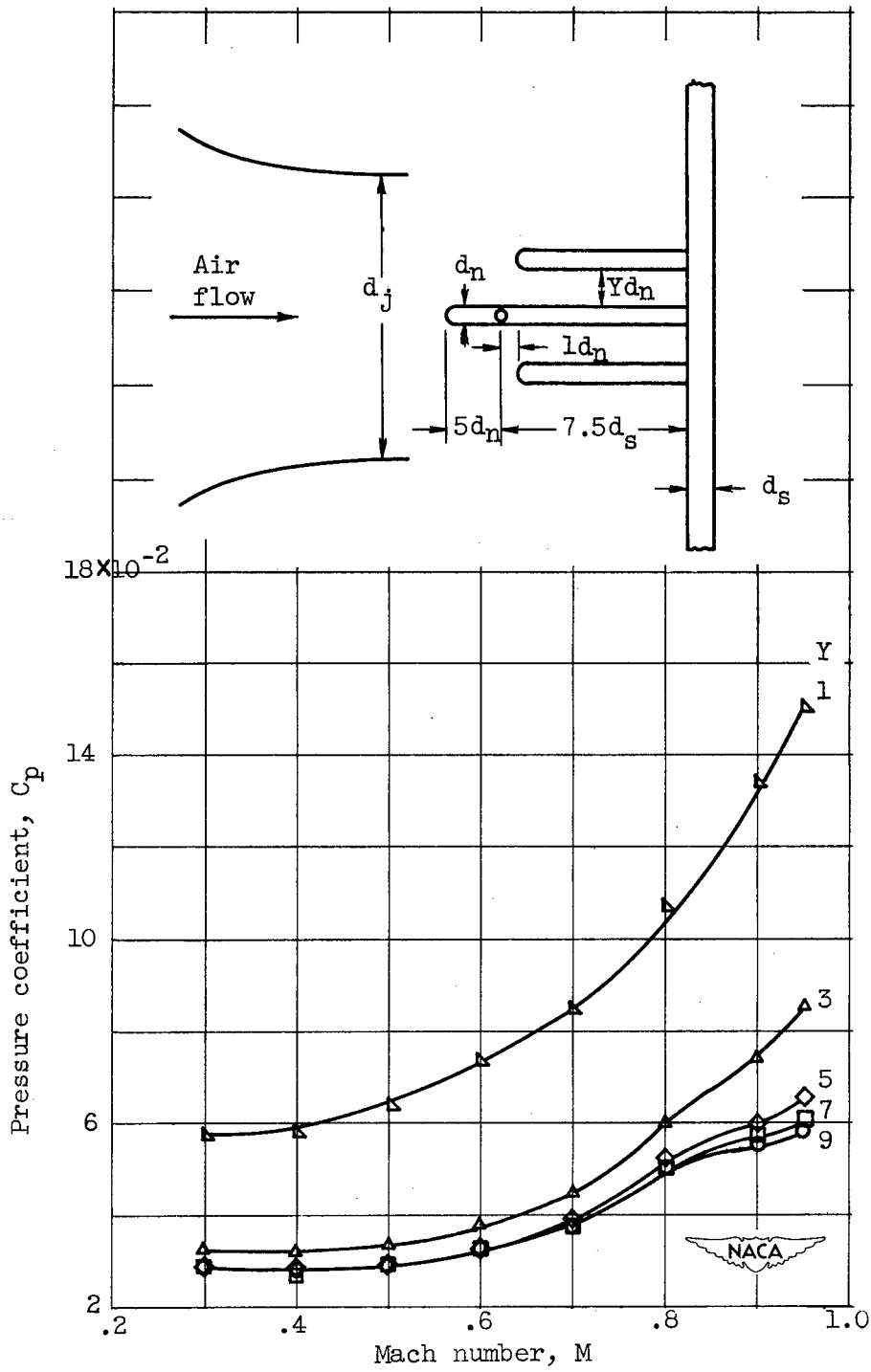

(a) Leading edge of adjacent tube located 1 diameter downstream of static orifices.

Figure 7. - Variation of pressure coefficient with Mach number for adjacent tubes at distance Yd_n from static-pressure tube; d_n/d_s , 0.5; d_s/d_j , 0.036.

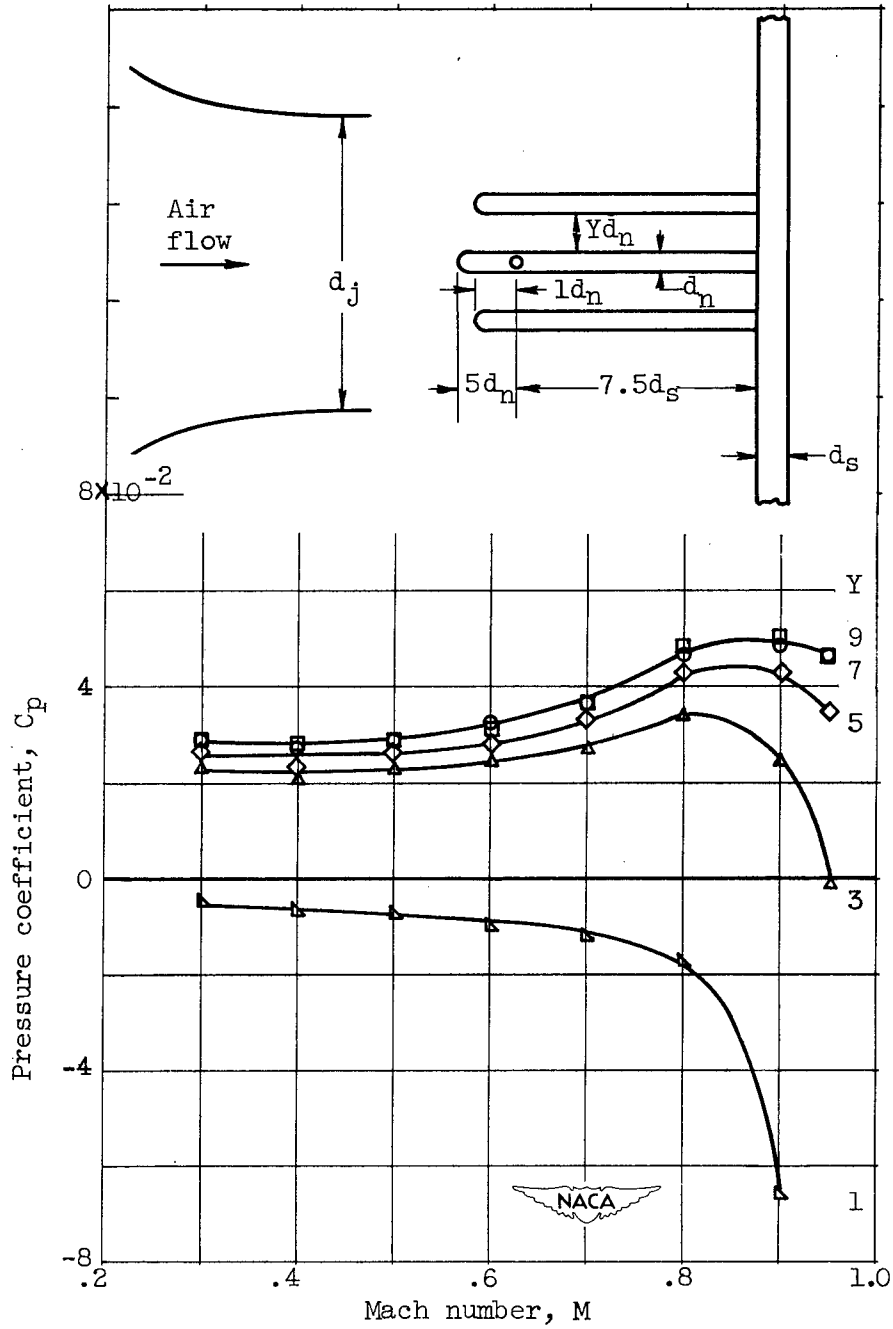

(b) Leading edge of adjacent tube located 1 diameter upstream of static orifices.

Figure 7. - Concluded. Variation of pressure coefficient with Mach number for adjacent tubes at distance Yd_n from static-pressure tube; $d_n/d_s, 0.5$; $d_s/d_j, 0.036$.

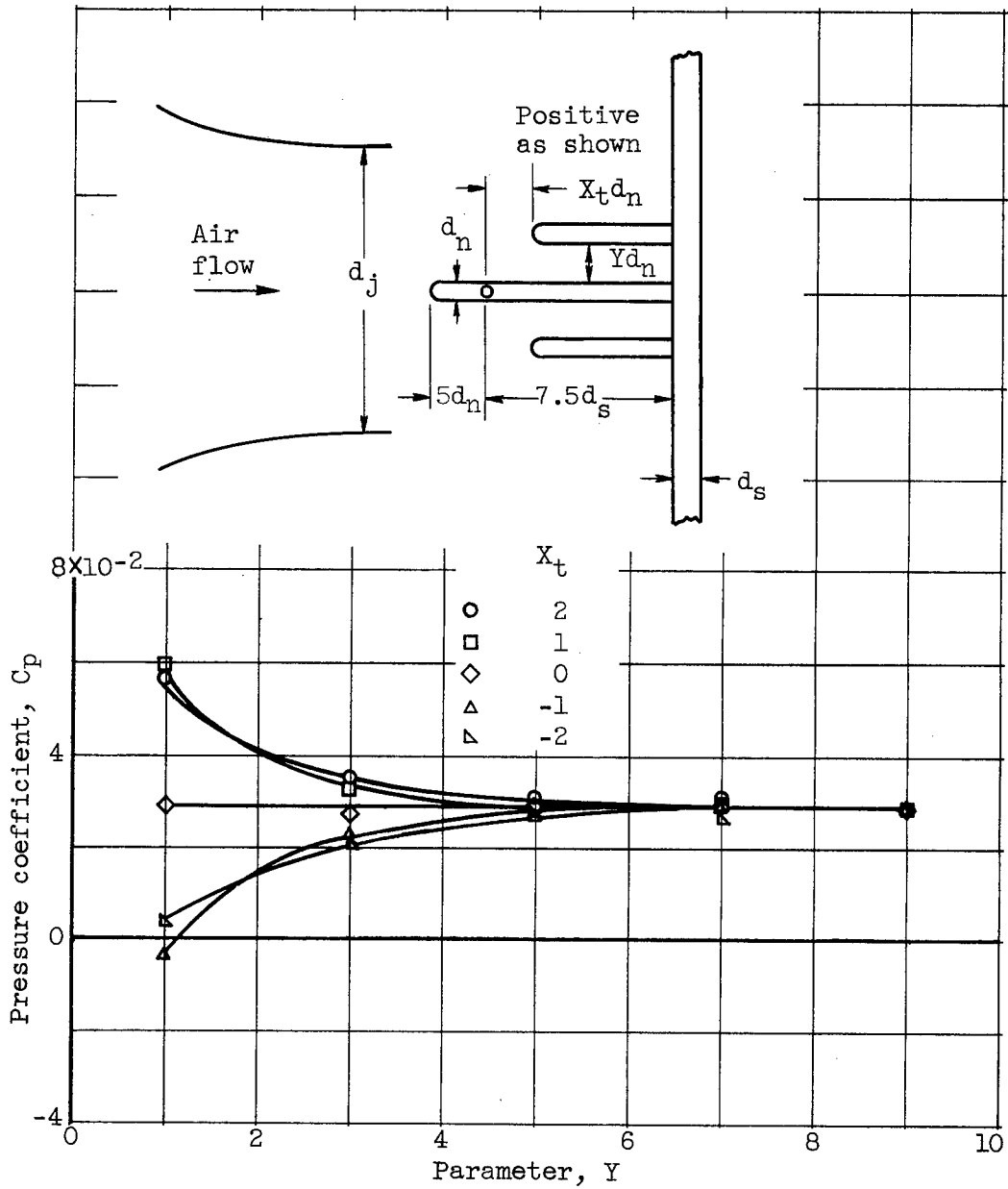

(a) Mach number, $M = 0.3$.

Figure 8. - Variation of pressure coefficient with distance between adjacent and static-pressure tubes for leading edge of adjacent tube located at distance $X_t d_n$ from static orifices; $d_n/d_s, 0.5$; $d_s/d_j, 0.036$.

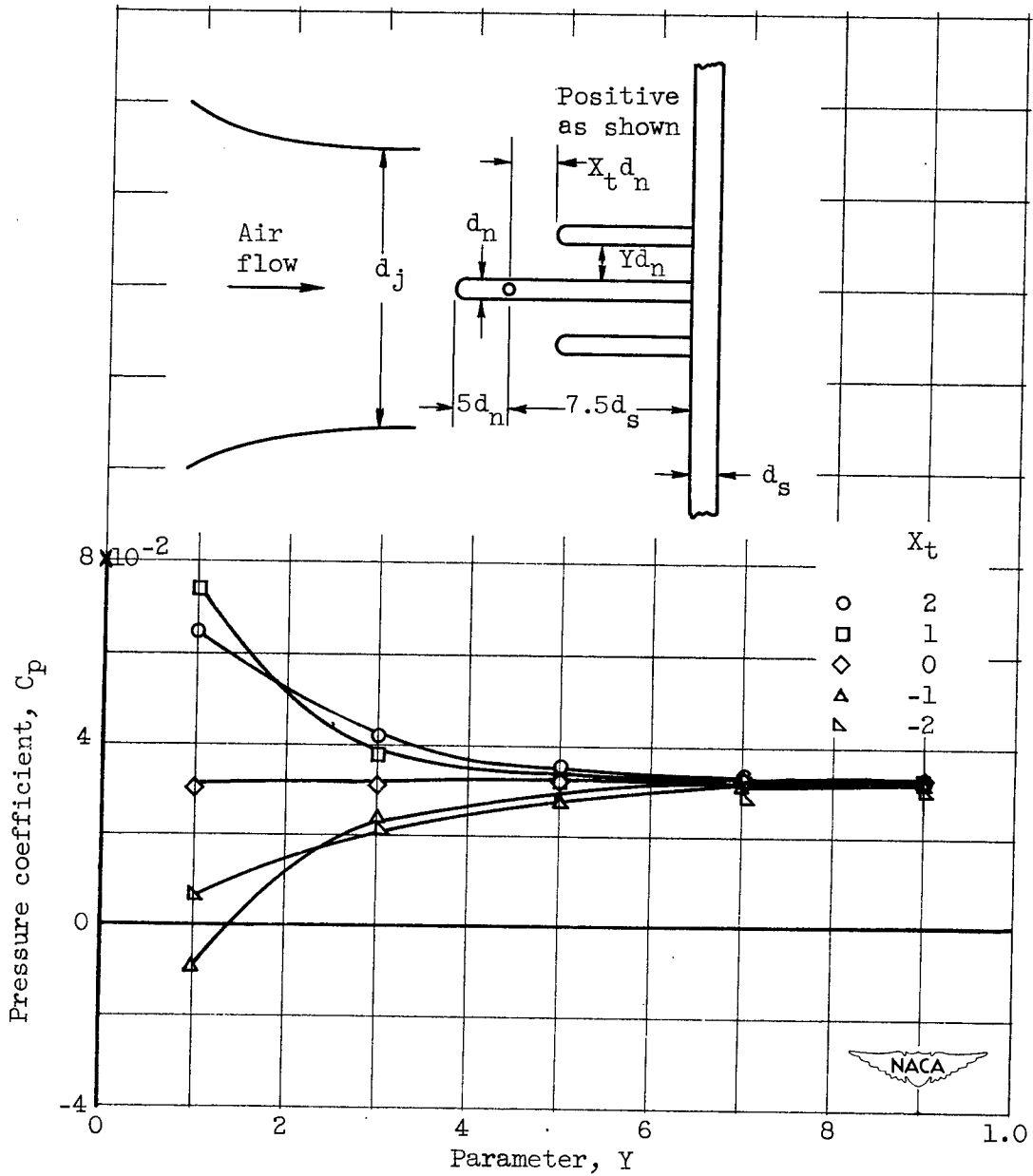

(b) Mach number, $M = 0.6$.

Figure 8. - Continued. Variation of pressure coefficient with distance between adjacent and static-pressure tubes for leading edge of adjacent tube located at distance $X_t d_n$ from static orifices; $d_n/d_s, 0.5$; $d_s/d_j, 0.036$.

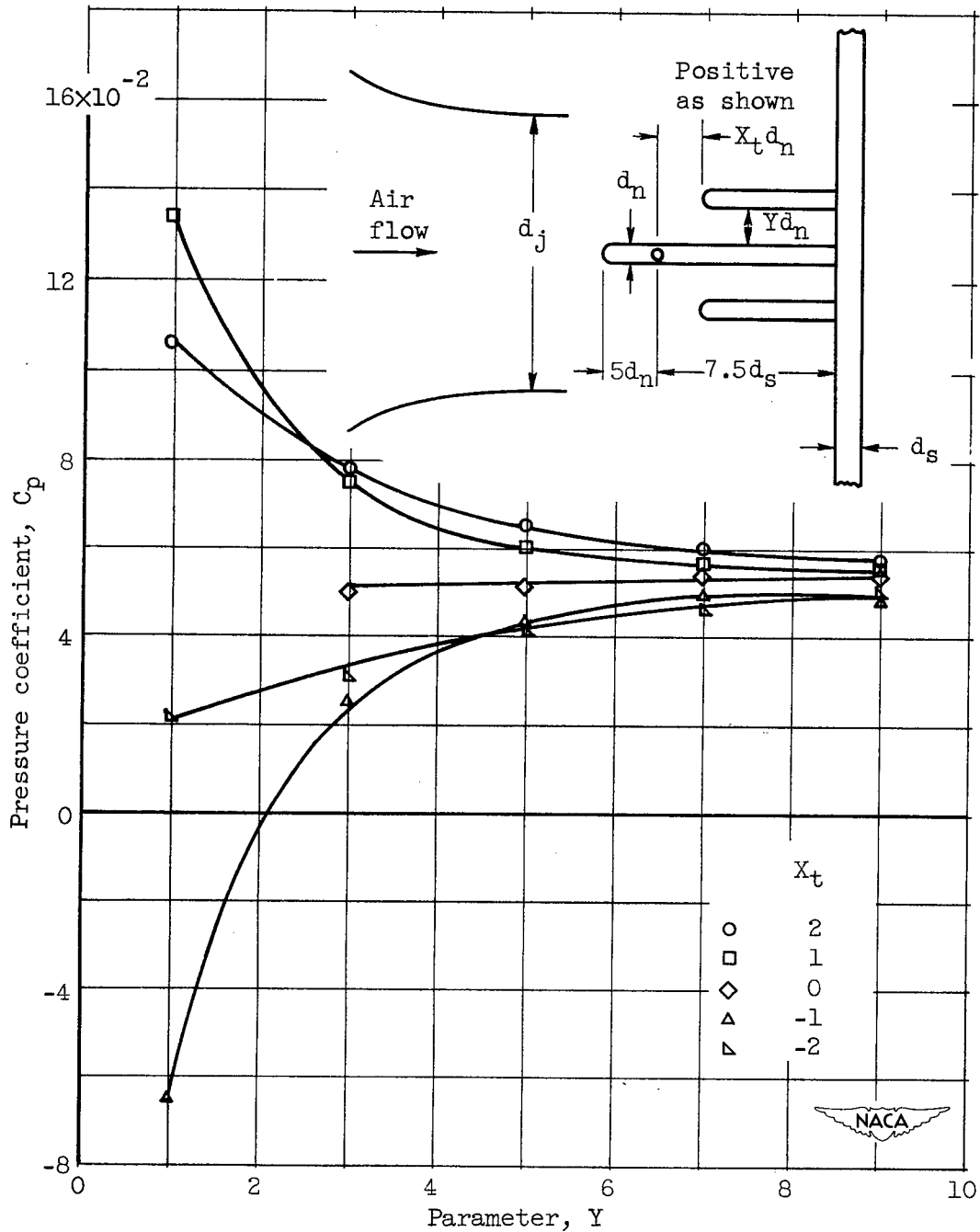

(c) Mach number, $M = 0.8$.

Figure 8. - Concluded. Variation of pressure coefficient with distance between adjacent and static-pressure tubes for leading edge of adjacent tube located at distance $X_t d_n$ from static orifices; $d_n/d_s, 0.5$; $d_s/d_j, 0.036$.