

NACA TN 2135

8/4/50
gml

NATIONAL ADVISORY COMMITTEE FOR AERONAUTICS

TECHNICAL NOTE 2135

THE CALCULATION OF DOWNWASH BEHIND WINGS OF ARBITRARY
PLAN FORM AT SUPERSONIC SPEEDS

By John C. Martin

Langley Aeronautical Laboratory
Langley Air Force Base, Va.



Reproduced From
Best Available Copy

Washington
July 1950

DISTRIBUTION STATEMENT A
Approved for Public Release
Distribution Unlimited

20000731 196

DTIC QUALITY INSPECTED 4

AQM00-10-3362

NATIONAL ADVISORY COMMITTEE FOR AERONAUTICS

TECHNICAL NOTE 2135

THE CALCULATION OF DOWNWASH BEHIND WINGS OF ARBITRARY
PLAN FORM AT SUPERSONIC SPEEDS

By John C. Martin

SUMMARY

Exact and approximate methods based upon linearized supersonic flow theory have been developed for the calculation of the velocity potential and the downwash from thin wings of arbitrary plan form. Particular attention is given to the evaluation of the downwash in the plane of the wing. The applicability of the method inherently depends upon a knowledge of the load distribution over the plan form of the wing. General expressions for the velocity potential and downwash have been derived. Simple modifications of these expressions produced formulas for the velocity potential and downwash from arbitrary curved lifting lines.

A complete development of all formulas, starting with the basic solution of the linearized potential equation for supersonic flow, is given. Although the paper contains many new results, some of the results presented have been obtained by other methods and are given here solely for completeness. The general formulation of the downwash equations can easily be used in finding exact and approximate expressions for the other velocity components.

The results of the theoretical development are used to determine the downwash from a pitching rectangular wing and to determine the expression for the local angle of attack necessary to give a specified load distribution. Comparisons of the exact and approximate values of the downwash for several lifting-line configurations are also presented.

INTRODUCTION

The calculation of the downwash fields induced by thin wings at supersonic speeds is necessary in order to evaluate accurately the aerodynamic load distribution over the tail, an important consideration for structural and stability calculations. Available methods, including the present, are based on the linearized-time-independent flow considerations. These methods, in general, utilize the following well-known concepts: conical flows, potential doublets, vortices, and pressure doublets. The

conical-flow method is used in reference 1 to calculate the downwash flow fields in the plane of the wing for several plan forms including the rectangular wing. The potential-doublet method is presented in reference 2 and is used to find the downwash behind a triangular wing over a range of Mach numbers in reference 3. The vortex method is developed for supersonic-flow applications in references 4 and 5 and is used in reference 6 to find the downwash due to thin wings approximated by lifting lines. The method used in reference 7 was the potential-doublet method; however, by integration by parts Ward obtained an expression for the velocity potential in space which agrees with the expression for the velocity potential in space determined herein.

The present method is essentially a development of the pressure-doublet method for the calculation of downwash flow fields. This method leads easily to expressions for the velocity potential and the downwash from arbitrary curved lifting lines. These expressions in turn lead to approximate expressions for the downwash from lifting lines. These approximate expressions have many computational advantages.

The method described herein has certain advantages in that most of the important results obtained by other methods can be obtained without difficulty by using the present approach. Integrations are performed only on the plan form; whereas other methods, excluding the conical-flow method, generally lead to integrations on the plan form and over the wake. An attempt was made to present a fairly complete development of the pressure-doublet method and at the same time present results which have not been obtained by other methods.

The accuracy of the developed approximate formulas is brought out in the evaluation of a rectangular pitching wing by use of exact (linearized) and approximate expressions. Comparisons are made between exact calculations of the downwash from certain lifting lines and approximate expressions. Other applications include some simple derivations of known results plus an expression for the local angle of attack necessary to give a specified load distribution.

SYMBOLS

c	chord
b/2	semispan
L_1, L_2	x_1 limits of integration
P	pressure coefficient $\left(\text{Pressure} / \frac{1}{2} \rho V^2 \right)$
f	denotes finite part of integral

$f(y_1)$	equation of an arbitrary line
i	variable index
k	a constant
h_1, h_2	y_1 limits of integration
M	free-stream Mach number
m	slope of line
n, n_1, n_2	limits of summation
q	angular velocity about y-axis
$R' = \sqrt{X^2 - \beta^2(Y^2 + Z^2)}$	
$R = \sqrt{X^2 - \beta^2(Y^2 + z^2)}$	
$R(\lambda) = \sqrt{(\lambda - x_1)^2 - \beta^2(Y^2 + Z^2)}$	
V	free-stream velocity
$X = x - x_1, Y = y - y_1, Z = z - z_1, X_i = x - x_i, Y_i = y - y_i$	
x, y, z, x_1, y_1, z_1	Cartesian coordinates
$\delta x_1, \delta y_1$	increments in x_1 and y_1 , respectively
α	angle of attack
$\beta = \sqrt{M^2 - 1}$	
Γ	circulation
ϵ	a small positive number
λ	an auxiliary variable
ρ	free-stream density
σ	local angle of attack

τ	area of plan form in forward Mach cone from point (x,y,z)
τ'	area of plan form and wake in forward Mach cone from point (x,y,z)
ϕ	perturbation velocity potential
$\delta\phi$	increment in velocity potential at point (x,y,z) due to an elementary lifting area at point $(x_1,y_1,0)$
$\Delta\phi_{x_1}$	difference in partial derivative of ϕ with respect to x_1 ($\phi_{x_1u} - \phi_{x_1l}$)
$\Delta\phi_{TE}$	value of potential difference at trailing edge ($\phi_{TEu} - \phi_{TEl}$)
$(\phi_z)_I, (\phi_z)_{II}, (\phi_z)_{III}$	vertical perturbation velocity at point (x,y,z) due to regions I, II, and III, respectively
\oint_{MC}	line integral around area of plan form in forward Mach cone from point $(x,y,0)$
Subscripts:	
u, l	upper and lower surfaces, respectively
x, y, z	partial derivatives with respect to x , y , and z , respectively
TE	trailing edge

THEORY

The theoretical development is divided into three parts: First, general formulas are derived for the potential and the upwash in space due to a thin lifting surface; the pressure distribution on the surface is assumed to be known. Second, because the formulas in the first part are in many cases difficult to evaluate, the expressions for the thin wing are used to develop formulas for the potential or upwash in space due to lifting lines. Third, because in some cases the expressions for lifting lines are difficult to evaluate, approximate expressions are also derived for the upwash from lifting lines.

Lifting Surfaces

Potential in space.- The partial-differential equation satisfied by the perturbation velocity potential in supersonic flow is

$$\beta^2 \frac{\partial^2 \phi}{\partial x^2} - \frac{\partial^2 \phi}{\partial y^2} - \frac{\partial^2 \phi}{\partial z^2} = 0 \quad (1)$$

A general solution of equation (1) is given in reference 8. (The boundary conditions for airfoils are given in reference 9.) For the purposes of the present paper this solution may be written in the form

$$\phi(x, y, z) = \frac{1}{2\pi} \int\limits_{\tau'}^f (\phi_u - \phi_l) \frac{\partial}{\partial z_1} \left(\frac{1}{R'} \right) dx_1 dy_1 \quad (2)$$

where ϕ_u and ϕ_l are the values of ϕ on the upper and lower sides of the surface $z = z_1$. The finite part of the integral in equation (2) must be taken as indicated by the symbol f . The double integrals that arise will be dealt with according to the methods for finding the finite part of the multiple integrals given by Hadamard in reference 8. The area of integration τ' is the area of the $z = z_1$ plane for which

$$x_1 \leq x - \beta \sqrt{y^2 + z^2}$$

Equation (2) remains valid when the velocity potential is replaced by its partial derivative with respect to the free-stream direction. Since the pressure is directly proportional to ϕ_x , replacing ϕ by ϕ_x in equation (2) has the effect of introducing a potential which is directly proportional to the acceleration potential.

Since

$$\phi(x, y, z) = \int_{-\infty}^x \phi_x(\lambda, y, z) d\lambda \quad (3)$$

it follows from equation (2) that

$$\phi(x, y, z) = \frac{1}{2\pi} \int_{-\infty}^x \int\limits_{\tau}^f (\phi_{x_1 u} - \phi_{x_1 l}) \frac{\partial}{\partial z_1} \left[\frac{1}{R'(\lambda)} \right] dx_1 dy_1 d\lambda \quad (4)$$

where

$$R'(\lambda) = \sqrt{(\lambda - x_1)^2 - \beta^2(y^2 + z^2)}$$

The difference in ϕ_{x_1} , $\Delta\phi_{x_1}$, is zero except on the plan form; therefore, the region of integration τ is over the plan form only.

It is proved in reference 4 that the order of integration of the finite part of a multiple integral can be changed. Equation (4) for $z_1 = 0$ can therefore be expressed in the form

$$\phi(x, y, z) = -\frac{1}{2\pi} \iint_{\tau} (\phi_{x_1 u} - \phi_{x_1 l}) \int_{-\infty}^x \frac{\beta^2 z}{R^3} d\lambda dx_1 dy_1 \quad (5)$$

The integral

$$\int_{-\infty}^x \frac{\beta^2 z}{R^3} d\lambda$$

must be integrated from the aftercone emanating from point $(x_1, y_1, 0)$ to the point (x, y, z) because a disturbance at point $(x_1, y_1, 0)$ only affects points in the aftercone from the point $(x_1, y_1, 0)$. The value of

the preceding integral is $\frac{-zX}{(Y^2 + z^2)R}$.

Equation (5) now becomes

$$\phi(x, y, z) = \frac{1}{2\pi} \iint_{\tau} \frac{\Delta\phi_{x_1} zX}{(Y^2 + z^2)R} dx_1 dy_1 \quad (6)$$

In general, equation (6) is a finite integral; therefore, the finite-parts symbol has been dropped. The expression for the velocity potential given by equation (6) was obtained in reference 7 by a different approach as indicated in the introduction. Equation (6) may also be readily obtained from Volterra's solution (reference 10).

Upwash in space.- Perhaps the most frequently desired quantity is the upwash ϕ_z . It is shown in the appendix that equation (6) may be differentiated with respect to z under the integral signs without consideration of the variable limits. The result of differentiating both sides of equation (6) with respect to z is

$$\phi_z = \frac{1}{2\pi} \iint_{\tau} \frac{\Delta\phi_{x_1} [(Y^2 - z^2)R^2 + \beta^2 z^2 (Y^2 + z^2)] X}{(Y^2 + z^2)^2 R^3} dx_1 dy_1 \quad (7)$$

An expression for the sidewash due to a discontinuous pressure sheet can be obtained in a manner similar to that used in finding equation (7).

Upwash in the wake.- In the $z = 0$ plane for points not on the plan form or in the wake, equation (7) reduces to the form

$$\phi_z = \frac{1}{2\pi} \iint_{\tau} \frac{\Delta\phi_{x_1} X}{Y^2 R} dx_1 dy_1 \quad (8)$$

The restrictions on equation (8) can easily be understood by comparing it with equation (6). Equation (6) is an expression for the potential in space due to a discontinuous pressure sheet. For points not on the plan form or in the wake, it can be seen from equations (6) and (8) that

$$\phi_z(x, y, 0) = \lim_{z \rightarrow 0} \frac{1}{z} \phi(x, y, z)$$

The preceding expression shows that in order for the right side of the expression to be finite the potential must approach zero as z approaches zero. It is well-known that the potential is zero in the $z = 0$ plane for zero-thickness wings except on the plan form or in the wake where the potential has a finite discontinuity across this plane. Because ϕ_z is in general finite and since the potential has a finite discontinuity across the $z = 0$ plane in the wake and on the plan form, equation (8) cannot hold on the plan form or in the wake.

Equation (7) may be used to find ϕ_z for points on the plan form or in the wake by performing the integrations for an arbitrary z and then setting z equal to zero. Generally the integrations for an arbitrary z are very difficult. Both integrations of equation (7) must be

performed for points on the plan form; whereas, only the integration with respect to y_1 is needed for points in the wake. The reason that one or both integrations must be performed before taking the limit of ϕ_z as z approaches zero is that the integrand tends to infinity along the line $y_1 = y$ as z approaches zero. The line $y_1 = y$ must therefore be removed from the area of integration. This line may be removed by removing a narrow strip, of width ϵ , on each side of the line $y_1 = y$ from the area of integration. (See fig. 1(a).) The integrations must be performed until the width ϵ is removed from the limits of integration. The limit of ϕ_z as z approaches zero may then be taken. The limit of ϕ_z as z approaches zero cannot be taken until the limit of ϕ_z as ϵ approaches zero is taken unless the effect of the strip is considered. Figure 1(b) shows the area of integration necessary to evaluate a point in the wake. It can be seen from this figure that the x_1 limits are independent of ϵ ; therefore, for points in the wake the x_1 integration need not be performed before the limits are taken.

The calculation of ϕ_z for points on the plan form or in the wake can be considerably simplified by using a combination of equation (7) and equation (8). For points in the wake, divide the area of integration as shown in figure 2. Each region of the integration may be considered as an independent wing with a local angle of attack necessary to give the load distribution of the region. Since regions I and III can be considered as being two different plan forms, equation (8) can be applied to regions I and III, but equation (7) must be applied to region II. The value of ϵ is chosen small; therefore, in region II the variation of $\Delta\phi_x$ with y_1 can be neglected in the first approximation provided the pressure is continuous over the plan form. Pressure discontinuities may be dealt with by subdividing the regions of integration.

The contribution of regions I and III to the vertical perturbation velocity when $z = 0$ is

$$(\phi_z)_{I+III} = \frac{1}{2\pi} \iint_{I+III} \frac{\Delta\phi_{x_1} x}{Y^2 R} dx_1 dy_1 \quad (9)$$

For a point above the wake the effect of region II is approximately

$$(\phi_z)_{II} \approx \frac{1}{2\pi} \int_{L_1}^{L_2} \int_{y-\epsilon}^{y+\epsilon} \frac{\Delta\phi_{x_1}(x_1, y, 0) x \left[(Y^2 - z^2)R^2 + \beta^2 z^2 (Y^2 + z^2) \right]}{(Y^2 + z^2)^2 R^3} dx_1 dy_1 \quad (10)$$

where $\Delta\phi_x(x_1, y, 0)$ is the difference in ϕ_x across the lifting surface along the line $y_1 = y$. The x_1 limits are denoted by L_1 and L_2 . After integration with respect to y_1 equation (10) becomes

$$(\phi_z)_{II} \approx \frac{1}{2\pi} \int_{L_1}^{L_2} \frac{\Delta\phi_{x_1}(x_1, y, 0) XY (R^2 - \beta^2 z^2)}{(X^2 - \beta^2 z^2)(Y^2 + z^2) R} \Big|_{y-\epsilon}^{y+\epsilon} dx_1$$

and for $z = 0$

$$(\phi_z)_{II} \approx -\frac{1}{\pi\epsilon} \int_{L_1}^{L_2} \frac{\Delta\phi_{x_1}(x_1, y, 0) \sqrt{X^2 - \beta^2 \epsilon^2}}{X} dx_1 \tag{11}$$

For points in the wake the resultant vertical perturbation velocity is then given by the sum of equations (9) and (11):

$$\phi_z(x, y, 0) \approx \frac{1}{2\pi} \iint_{I+III} \frac{\Delta\phi_{x_1} X}{Y^2 R} dy_1 dx_1 - \frac{1}{\pi\epsilon} \int_{L_1}^{L_2} \frac{\Delta\phi_{x_1}(x_1, y, 0) \sqrt{X^2 - \beta^2 \epsilon^2}}{X} dx_1 \tag{12}$$

Equation (12) is approximate when ϵ is not zero; however, the accuracy of the approximation increases as ϵ approaches zero and of course in the limit the equation is exact. The exact vertical perturbation velocity is then given by

$$\phi_z(x, y, 0) = \lim_{\epsilon \rightarrow 0} \left[\frac{1}{2\pi} \iint_{I+III} \frac{\Delta\phi_{x_1} X}{Y^2 R} dy_1 dx_1 - \frac{1}{\pi\epsilon} \int_{L_1}^{L_2} \frac{\Delta\phi_{x_1}(x_1, y, 0) \sqrt{X^2 - \beta^2 \epsilon^2}}{X} dx_1 \right] \tag{13}$$

Equation (13) can be expressed in the form

$$\phi_z(x,y,0) = -\frac{1}{2\pi} \iint_{\tau} \frac{\Delta\phi_{x_1 y_1}^R}{XY} dx_1 dy_1 - \frac{1}{2\pi} \oint_{MC} \frac{\Delta\phi_{x_1} \sqrt{X^2 - \beta^2 Y^2}}{XY} dx_1 \quad (14)$$

where the second integral is a line integral around the region of the plan form affecting the point $(x,y,0)$. Equation (14) was obtained from equation (13) by integrating the first term by parts with respect to y_1 .

A consideration of the previous division of the plan form into regions with regard to vortex distributions is helpful in understanding the physical meaning of the preceding manipulations.

Equation (10) is the expression for the upwash from a series of horseshoe vortices distributed over region II. The y_1 component of the vortex strength is proportional to $\Delta\phi_x(x_1,y,0)$. The x_1 component of the vortex strength is zero except along $y - \epsilon$ and $y + \epsilon$. (See fig. 3.) The spanwise distribution of the trailing vortices consists of only two vortices of finite strength $\Delta\phi(x,y,0)$ located along

$$y_1 = y - \epsilon$$

and along

$$y_1 = y + \epsilon$$

Equation (9) can be considered as the expression for the vertical perturbation velocity due to a system of vortices. The integral over region I represents the effect of the bound and trailing vortices associated with region I plus a finite vortex (see fig. 3) along

$$y_1 = y - \epsilon$$

This finite vortex is the sum of the y -components of the vortex strength along

$$y_1 = y - \epsilon$$

Since the divergence of a vortex field is zero, it is not surprising that a vortex of finite strength exists along this line. The integral over region III represents the effects of the bound and trailing vortices associated with region III plus a vortex of finite strength along

$$y_1 = y + \epsilon$$

Equation (9) gives the effect on the field point of the vortex distribution on regions I and III, the trailing vortices associated with the vortices on regions I and III, and two vortices of finite strength located a distance ϵ on either side of the line $y_1 = y$. For any small value of ϵ the strengths of the two finite vortices are almost equal and, since the field point lies midway between these finite vortices, it follows that equation (9) should tend to infinity as ϵ approaches zero. The infinity arising from equation (9) as $\epsilon \rightarrow 0$ is exactly canceled by the infinity arising from equation (11) as $\epsilon \rightarrow 0$. A finite downwash then results at the point $(x, y, 0)$ within the wake region provided that the spanwise derivative of the load distribution is continuous at y .

Upwash on the plan form.- In order to simplify the calculation of ϕ_z on the plan form, consider an arbitrary point slightly above the plan form and divide the area of integration into regions as shown in figure 4. Region IV is small; therefore, the value of $\Delta\phi_{x_1}$ is approximately constant in region IV. For points slightly above the plan form the contribution of region IV to the vertical perturbation velocity is approximately

$$(\phi_z)_{IV} \approx \frac{\Delta\phi_x(x, y, 0)}{2\pi} \iint_{IV} x \frac{[(Y^2 - z^2)R^2 + \beta^2 z^2(Y^2 + z^2)]}{(Y^2 + z^2)2R^3} dx_1 dy_1 \quad (15)$$

The result of performing the integrations in equation (15) is

$$(\phi_z)_{IV} \approx -\frac{\beta}{2} \Delta\phi_x(x, y, 0) \quad (16)$$

Actually the point at the apex of the hyperbola is a singular point and must be removed from the region of integration by a method such as is given in reference 8, pages 147 to 150. The integrals over regions I, II, and III for points slightly above the plan form are given approximately by equation (14). The vertical perturbation velocity ϕ_z is then approximately given by (equation (14) plus equation (16)):

$$\phi_z = -\frac{1}{2\pi} \iint_T \frac{\Delta\phi_{x_1 y_1}^R}{XY} dx_1 dy_1 - \frac{1}{2\pi} \oint_{MC} \frac{\Delta\phi_{x_1}^R}{XY} dx_1 - \frac{\beta}{2} \Delta\phi_x(x, y, 0) \quad (17)$$

Equation (17) is independent of ϵ ; therefore, it is exact for points on the plan form. The result given by equation (17) was also obtained independently by Dr. A. Busemann of the Langley Laboratory in an unpublished analysis using a different approach.

Lifting Lines

Integrations that arise in evaluating the potential or the downwash from thin wings are in most cases very difficult to perform. For most downwash problems reference 6 indicates that a lifting line can be used as a very good approximation. In this reference, formulas are developed for the upwash in space due to lifting lines. In the present paper, formulas are developed for the velocity potential and the upwash in space due to lifting lines by using the same approach that was used to develop the previous formulas for the thin wings. The results for the upwash agree with the corresponding results of reference 6.

Potential due to a lifting line.- The potential or upwash due to an arbitrary curved lifting line can be found from the preceding results. The following expression for the infinitesimal increment in the potential due to an elementary lifting area can be obtained from equation (6):

$$\frac{\delta\phi(x, y, z)}{\delta x_1 \delta y_1} = \frac{\Delta\phi_{x_1} zX}{2\pi(Y^2 + z^2)R} \quad (18)$$

The potential from an element of a lifting line is then

$$d\phi(x, y, z) = \lim_{\delta x_1 \delta y_1 \rightarrow 0} \frac{\Delta\phi_{x_1} \delta x_1 zX \delta y_1}{2\pi(Y^2 + z^2)R} \quad (19)$$

where the product $\Delta\phi_{x_1} \delta x_1$ is held constant as δx_1 approaches zero. The product $\Delta\phi_{x_1} \delta x_1$ is the difference in potential because $\Delta\phi_{x_1}$ is constant in the x-direction. Since $\Delta\phi$ is also the circulation, equation (19) can be written

$$d\phi(x,y,z) = \frac{\Gamma z X}{2\pi(Y^2 + z^2)R} dy_1 \quad (20)$$

where Γ denotes the circulation at point (x_1, y_1) .

Let the equation of the curve denoting an arbitrary lifting line be

$$x_1 = f(y_1) \quad (21)$$

Substituting this function into equation (20) and integrating yields the equation

$$\phi(x,y,z) = \frac{1}{2\pi} \int_{h_1}^{h_2} \frac{z(x-f)\Gamma(y_1)}{(Y^2 + z^2)\sqrt{(x-f)^2 - \beta^2(Y^2 + z^2)}} dy_1 \quad (22)$$

Upwash due to a lifting line. - The derivative of equation (22) with respect to z is

$$\phi_z(x,y,z) = \frac{1}{2\pi} \int_{h_1}^{h_2} \frac{\{[(x-f)^2 - \beta^2 Y^2] Y^2 - z^2 [(x-f)^2 - \beta^2(Y^2 + 2z^2)]\} (x-f)\Gamma}{(Y^2 + z^2)^2 [(x-f)^2 - \beta^2(Y^2 + z^2)]^{3/2}} dy_1 \quad (23)$$

An expression for the sidewash due to a lifting line can be obtained in a similar manner. For points in the $z = 0$ plane not directly behind the lifting line, equation (23) reduces to

$$\phi_z(x,y,0) = \frac{1}{2\pi} \int_{h_1}^{h_2} \frac{(x-f)\Gamma(y_1)}{Y^2 \sqrt{(x-f)^2 - \beta^2 Y^2}} dy_1 \quad (24)$$

For points directly behind the lifting line, however, the equation of the lifting line must be known in order to evaluate equation (23) in the $z = 0$ plane.

Unbent lifting lines. - For a lifting line parallel to the y-axis located at $x = a$, equation (23) becomes

$$\phi_z(x,y,z) = \frac{1}{2\pi} \int_{h_1}^{h_2} \frac{\left\{ [(x-a)^2 - \beta^2 Y^2] Y^2 - z^2 [(x-a)^2 - \beta^2 (Y^2 + 2z^2)] \right\} (x-a) \Gamma}{(Y^2 + z^2)^2 [(x-a)^2 - \beta^2 (Y^2 + z^2)]^{3/2}} dy_1 \quad (25)$$

When integrated by parts, equation (25) becomes

$$\phi_z(x,y,z) = \frac{XY(R^2 - \beta^2 z^2) \Gamma(y_1)}{2\pi(X^2 - \beta^2 z^2)(Y^2 + z^2)R} \Big|_{h_1}^{h_2} - \frac{1}{2\pi} \int_{h_1}^{h_2} \frac{XY(R^2 - \beta^2 z^2) \frac{d\Gamma(y_1)}{dy_1}}{(X^2 - \beta^2 z^2)(Y^2 + z^2)R} dy_1 \quad (26)$$

When one or both limits of the first term of equation (26) are the intersection of the Mach cone from point (x,y,z) with the lifting line, these limits are neglected because only the finite part is to be taken. For lifting lines that represent airfoils, Γ is zero at each end of the line; therefore, in this case equation (26) becomes

$$\phi_z(x,y,z) = -\frac{1}{2\pi} \int_{h_1}^{h_2} \frac{XY(R^2 - \beta^2 z^2) \frac{d\Gamma(y_1)}{dy_1}}{(X^2 - \beta^2 z^2)(Y^2 + z^2)R} dy_1 \quad (27)$$

This result was obtained in reference 6 by using vortex theory.

When $\frac{d\Gamma(y_1)}{dy_1}$ is zero, equation (26) becomes

$$\phi_z(x,y,z) = \frac{X\Gamma}{2\pi(X^2 - \beta^2 z^2)} \left(\frac{\{X^2 - \beta^2 [(y - h_2)^2 + 2z^2]\} (y - h_2)}{[(y - h_2)^2 + z^2] \sqrt{X^2 - \beta^2 [(y - h_2)^2 + z^2]}} - \frac{\{X^2 - \beta^2 [(y - h_1)^2 + 2z^2]\} (y - h_1)}{[(y - h_1)^2 + z^2] \sqrt{X^2 - \beta^2 [(y - h_1)^2 + z^2]}} \right) \quad (28)$$

Equation (28) is the upwash from a horseshoe vortex; this result was first obtained in reference 11.

The velocity potential in space due to an unbent lifting line can be expressed in terms of Γ and $\frac{d\Gamma}{dy_1}$. Integrating equation (22) by parts gives

$$\phi(x,y,z) = \frac{\Gamma(y_1)}{2\pi} \tan^{-1} \frac{zR}{YX} \Big|_{h_1}^{h_2} - \frac{1}{2\pi} \int_{h_1}^{h_2} \tan^{-1} \frac{zR}{YX} \frac{d\Gamma}{dy_1} dy_1 \quad (29)$$

For a horseshoe vortex $\frac{d\Gamma}{dy_1}$ is zero and

$$\Gamma(h_1) = \Gamma(h_2)$$

therefore, the potential in space due to a horseshoe vortex is

$$\phi(x,y,z) = \frac{\Gamma}{2\pi} \left[\tan^{-1} \frac{z\sqrt{(x-a)^2 - \beta^2(y-h_2)^2 - \beta^2 z^2}}{(y-h_2)X} - \tan^{-1} \frac{z\sqrt{(x-a)^2 - \beta^2(y-h_1)^2 - \beta^2 z^2}}{(y-h_1)X} \right] \quad (30)$$

The components of the velocity can be found from equation (30) by differentiation.

Lifting line of constant slope.- The potential due to a lifting line of constant slope can be expressed as (from equation (22))

$$\phi = \frac{1}{2\pi} \int_{h_1}^{h_2} \frac{z \left(x - \frac{y_1 - k}{m} \right) \Gamma(y_1)}{(Y^2 + z^2) \sqrt{\left(x - \frac{y_1 - k}{m} \right)^2 - \beta^2(Y^2 + z^2)}} dy_1 \quad (31)$$

where the equation of the lifting line is

$$y_1 = mx_1 + k$$

When integrated by parts, equation (31) becomes

$$\phi = \frac{\Gamma(y_1)}{2\pi} \tan^{-1} \frac{z \sqrt{\left(x - \frac{y_1 - k}{m} \right)^2 - \beta^2(Y^2 + z^2)}}{Y \left(x - \frac{y_1 - k}{m} \right) - \frac{z^2}{m}} \Bigg|_{h_1}^{h_2}$$

$$\frac{1}{2\pi} \int_{h_1}^{h_2} \frac{d\Gamma(y_1)}{dy_1} \tan^{-1} \frac{z \sqrt{\left(x - \frac{y_1 - k}{m} \right)^2 - \beta^2(Y^2 + z^2)}}{Y \left(x - \frac{y_1 - k}{m} \right) - \frac{z^2}{m}} dy_1 \quad (32)$$

The potential due to a bent lifting line as shown in figure 5(a) is

$$\phi = \frac{\Gamma(b/2)}{2\pi} \tan^{-1} \frac{z \sqrt{\left(x - \frac{b}{2} - k\right)^2 - \beta^2 \left(y - \frac{b}{2}\right)^2 - \beta^2 z^2}}{\left(y - \frac{b}{2}\right) \left(x - \frac{b}{2} - k\right) - \frac{z^2}{m}}$$

$$\frac{\Gamma(-b/2)}{2\pi} \tan^{-1} \frac{z \sqrt{\left(x - \frac{b}{2} + k\right)^2 - \beta^2 \left(y + \frac{b}{2}\right)^2 - \beta^2 z^2}}{\left(y + \frac{b}{2}\right) \left(x - \frac{b}{2} + k\right) + \frac{z^2}{m}} +$$

$$\Gamma(0) \tan^{-1} \frac{mz \sqrt{\left(x + \frac{k}{m}\right)^2 - \beta^2 (y^2 + z^2)}}{y(mx + k) - z^2}$$

$$\Gamma(0) \tan^{-1} \frac{mz \sqrt{\left(x - \frac{k}{m}\right)^2 - \beta^2 (y^2 + z^2)}}{y(mx - k) - z^2}$$

$$\frac{1}{2\pi} \int_{-b/2}^0 \frac{d\Gamma}{dy_1} \tan^{-1} \frac{z \sqrt{\left(x - \frac{-y_1 + k}{m}\right)^2 - \beta^2 (y^2 + z^2)}}{Y \left(x - \frac{-y_1 + k}{m}\right) + \frac{z^2}{m}} dy_1 -$$

$$\frac{1}{2\pi} \int_0^{b/2} \frac{d\Gamma}{dy_1} \tan^{-1} \frac{z \sqrt{\left(x - \frac{y_1 - k}{m}\right)^2 - \beta^2 (y^2 + z^2)}}{Y \left(x - \frac{y_1 - k}{m}\right) - \frac{z^2}{m}} dy_1$$

(33)

where m is the slope of the bent lifting line when y is positive (see fig. 5). When the lifting line is used to approximate a wing, $\Gamma(-b/2)$ and $\Gamma(b/2)$ are zero. The components of the velocity for a bent lifting line can be found by differentiation of equation (33).

When $d\Gamma(y_1)/dy_1$ is zero equation (33) becomes

$$\phi = \frac{\Gamma}{2\pi} \left[\tan^{-1} \frac{z \sqrt{\left(x - \frac{b}{2} - k\right)^2 - \beta^2 \left(y - \frac{b}{2}\right)^2 - \beta^2 z^2}}{\left(y - \frac{b}{2}\right) \left(x - \frac{b}{2} - k\right) - \frac{z^2}{m}} - \right.$$

$$\tan^{-1} \frac{z \sqrt{\left(x - \frac{b}{2} + k\right)^2 - \beta^2 \left(y + \frac{b}{2}\right)^2 - \beta^2 z^2}}{\left(y + \frac{b}{2}\right) \left(x - \frac{b}{2} + k\right) + \frac{z^2}{m}} +$$

$$\tan^{-1} \frac{mz \sqrt{\left(x + \frac{k}{m}\right)^2 - \beta^2 (y^2 + z^2)}}{y(mx + k) - z^2} -$$

$$\left. \tan^{-1} \frac{mz \sqrt{\left(x - \frac{k}{m}\right)^2 - \beta^2 (y^2 + z^2)}}{y(mx - k) + \frac{z^2}{m}} \right] \quad (34)$$

Equation (34) is the expression for the potential in space due to a vortex of constant strength as shown in figure 5(b). Since the velocity components can be found by differentiation, the upwash is given by

$$\begin{aligned}
 \phi_z = \frac{\Gamma}{2\pi} & \left(\frac{[(y - h_2)(mx - y) + z^2] [(mx - h_2)^2 - \beta^2 m^2 (y - h_2)^2] - 2\beta^2 m^2 z^2 (y - h_2)(mx - y)}{m [(y - h_2)^2 + z^2] [(mx - y)^2 + z^2 (1 - \beta^2 m^2)]} \sqrt{\left(x - \frac{h_1}{m}\right)^2 - \beta^2 [(y - h_2)^2 + z^2]} \right. \\
 & \left. \frac{[-(y - h_1)(mx + y) + z^2] [(mx + h_1)^2 - \beta^2 m^2 (y - h_1)^2] + 2\beta^2 m^2 z^2 (y - h_1)(mx + y)}{-m [(y - h_1)^2 + z^2] [(mx + y)^2 + z^2 (1 - \beta^2 m^2)]} \sqrt{\left(x + \frac{h_1}{m}\right)^2 - \beta^2 [(y - h_1)^2 + z^2]} \right. \\
 & \left. \frac{m \{ [-y(mx + y) + z^2] (x^2 - \beta^2 y^2) + 2\beta^2 z^2 y (mx + y) \}}{(y^2 + z^2) [(mx + y)^2 + z^2 (1 - \beta^2 m^2)]} \sqrt{x^2 - \beta^2 (y^2 + z^2)} \right. \\
 & \left. \frac{m \{ [y(mx - y) + z^2] (x^2 - \beta^2 y^2) - 2\beta^2 z^2 y (mx - y) \}}{(y^2 + z^2) [(mx - y)^2 + z^2 (1 - \beta^2 m^2)]} \sqrt{x^2 - \beta^2 (y^2 + z^2)} \right) \tag{35}
 \end{aligned}$$

where the origin of the axes has been transformed to the point $\left(\frac{k}{m}, 0, 0\right)$ of the original system of axes. Equation (35) can be obtained from the results of reference 6.

Approximations to the Upwash from Lifting Lines

Although the integrals that arise when lifting lines are used are much easier to evaluate than the integrals of exact lifting-surface expressions, many of the integrals that arise in connection with the use of lifting lines cannot be evaluated in closed form and many involve singularities. It is therefore desirable to obtain approximate expressions for lifting lines.

Approximation of an unbent lifting line.- Equation (28) can be used to approximate an unbent lifting line by a series of horseshoe vortices. The upwash from a series of horseshoe vortices that approximate the circulation by a series of steps as shown in figure 6(a) is

$$\phi_z = -\frac{1}{2\pi} \sum_{i=0}^n \frac{XY_i(X^2 - \beta^2 Y_i^2 - 2\beta^2 z^2) [\Gamma(y_i) - \Gamma(y_{i-1})]}{(X^2 - \beta^2 z^2)(Y_i^2 + z^2) \sqrt{X^2 - \beta^2 Y_i^2 - \beta^2 z^2}} \quad (36)$$

where Y_i denotes $y - y_i$ and i takes on all integral values from 0 to n . The upwash from a series of horseshoe vortices that approximates the circulation by a series of steps as shown in figure 6(b) is

$$\phi_z = -\frac{1}{2\pi} \sum_{i=0}^n \frac{XY_i(X^2 - \beta^2 Y_i^2 - 2\beta^2 z^2) [\Gamma(y_{i+1}) - \Gamma(y_i)]}{(X^2 - \beta^2 z^2)(Y_i^2 + z^2) \sqrt{X^2 - \beta^2 Y_i^2 - \beta^2 z^2}} \quad (37)$$

The average of equations (36) and (37) is

$$\phi_z = -\frac{1}{4\pi} \sum_{i=0}^n \frac{XY_i(X^2 - \beta^2 Y_i^2 - 2\beta^2 z^2) [\Gamma(y_{i+1}) - \Gamma(y_{i-1})]}{(X^2 - \beta^2 z^2)(Y_i^2 + z^2) \sqrt{X^2 - \beta^2(Y_i^2 + z^2)}} \quad (38)$$

Equation (38) is the upwash from a series of horseshoe vortices which approximates the circulation by a series of steps as shown in figure 6(c). In general, for points directly behind the lifting line, equation (38) should give best agreement with the exact lifting line when y (the coordinate for the field point) is midway between consecutive values of y_i . An expression for the sidewash may easily be obtained by using the sidewash due to a horseshoe vortex in the same manner that the upwash due to a horseshoe vortex was used in obtaining equation (38).

Approximation of bent lifting lines.- A bent lifting line can be approximated by a series of vortices of the form shown in figure 7 plus terms giving the effect of the bend in the center of the lifting line. Figure 8 shows a series of vortices of the form shown in figure 7 distributed along a bent lifting line. The upwash from such a system of vortices is

$$\phi_z = \frac{1}{4\pi} \sum_{i=1}^0 \left\{ \frac{[(y - y_i)(-mx - y) + z^2] [(mx + y_1)^2 - \beta^2 m^2 (y - y_1)^2] - 2\beta^2 m^2 z^2 (y - y_1)(-mx - y)}{-m [(y - y_1)^2 + z^2] [(mx + y)^2 + z^2 (1 - \beta^2 m^2)]} \sqrt{\left(x + \frac{y_1}{m}\right)^2 - \beta^2 (y - y_1)^2 - \beta^2 z^2} \right\} [\Gamma(y_{i+1}) - \Gamma(y_{i-1})]$$

$$\frac{1}{4\pi} \sum_{i=0}^{n_2} \left\{ \frac{[(y - y_i)(mx - y) + z^2] [(mx - y_1)^2 - \beta^2 m^2 (y - y_1)^2] - 2\beta^2 m^2 z^2 (y - y_1)(mx - y)}{m [(y - y_1)^2 + z^2] [(mx - y)^2 + z^2 (1 - \beta^2 m^2)]} \sqrt{\left(x - \frac{y_1}{m}\right)^2 - \beta^2 (y - y_1)^2 - \beta^2 z^2} \right\} [\Gamma(y_{i+1}) - \Gamma(y_{i-1})]$$

$$\frac{\Gamma(0)m \left\{ [-y(mx + y) + z^2] (x^2 - \beta^2 y^2) + 2\beta^2 z^2 y (mx + y) \right\}}{2\pi(y^2 + z^2) [(mx + y)^2 + z^2 (1 - \beta^2 m^2)]} \sqrt{x^2 - \beta^2 (y^2 + z^2)}$$

$$\frac{\Gamma(0)m \left\{ [y(mx - y) + z^2] (x^2 - \beta^2 y^2) - 2\beta^2 z^2 y (mx - y) \right\}}{2\pi(y^2 + z^2) [(mx - y)^2 + z^2 (1 - \beta^2 m^2)]} \sqrt{x^2 - \beta^2 (y^2 + z^2)} \tag{39}$$

where n_1 is related to negative values of y and n_2 is related to positive values of y . The first term on the right side represents the vortices for negative values of y ; the second represents the vortices for positive values of y . The remaining terms take into account the effect of the bend in the center of the lifting line. Equation (39) is set up for a distribution of vortices as shown in figure 8.

Equation (38) can be used to approximate a bent lifting line if X is replaced by X_i where X_i denotes $x - x_i$. When this is done, the result is

$$\phi_z = -\frac{1}{4\pi} \sum_{i=0}^n \frac{X_i Y_i (X_i^2 - \beta^2 Y_i^2 - 2\beta^2 z^2) [\Gamma(y_{i+1}) - \Gamma(y_{i-1})]}{(X_i^2 - \beta^2 z^2)(Y_i^2 + z^2) \sqrt{X_i^2 - \beta^2(Y_i^2 + z^2)}} \quad (40)$$

Equation (40) approximates a bent lifting line by adding the effects of a series of horseshoe vortices as shown in figure 9(a) when the circulation is symmetrical about the center of the lifting line, and when the points (x_i, y_i) are chosen symmetrically about the center of the lifting line. When the circulation is not symmetrical and/or the points (x_i, y_i) are not chosen symmetrically about the center of the lifting line, equation (40) approximates a bent lifting line by a series of vortices as shown in figure 9(b). The downwash from an infinite line vortex of constant strength and infinite slope is zero; therefore, equation (40) should give a reasonable approximation to a bent lifting line.

Résumé and Discussion of Theoretical Development

In the theoretical development exact and approximate formulas have been developed for the potential and the upwash due to thin wings. An expression for the potential in space due to a thin wing was derived from an expression for the partial derivative of the potential with respect to the free-stream direction. The upwash was found by differentiation of this expression. Formulas are derived for the upwash in the wake and on the plan form. The results of the exact expression for thin wings were used to find the potential and the upwash due to lifting lines, and the exact expressions for lifting lines were used to find approximate expressions for lifting lines.

In actual calculations better approximations to lifting surfaces may be obtained by using several lifting lines or their approximations distributed along the chord. Another approach would be to distribute finite vortices over the plan form. Either of the preceding methods

may be used to find a good approximation to the downwash from a lifting surface, provided that the apex of the hyperbola formed by the intersection of the Mach cone with the plane of the wing does not lie on the plan form. For cases where the apex is on the plan form there is a finite contribution along the Mach cone. This contribution may be evaluated by the same method that was used to evaluate the double integral in equation (15).

It should be remembered that this paper does not discuss the effects of thickness; however, these effects may be evaluated rather simply by use of source distributions.

APPLICATIONS

The results of the theoretical development can be applied to a number of problems. A few of these problems will be considered here.

Potential and Upwash at Infinity

When x approaches infinity equation (6) becomes

$$\phi(\infty, y, z) = \frac{z}{2\pi} \iint_T \frac{\Delta\phi_{x_1}}{y^2 + z^2} dx_1 dy_1$$

Since

$$\Delta\phi(x, y, z) = \int_{L.E.}^x \Delta\phi_{x_1} dx$$

integrating the preceding expression with respect to x_1 gives

$$\phi(\infty, y, z) = \frac{z}{2\pi} \int_{h_1}^{h_2} \frac{\Delta\phi_{TF}}{y^2 + z^2} dy_1 \quad (41)$$

Equation (41) is the same equation as the equation for the potential at infinity behind an airfoil in subsonic flow and is a well-known result noted in references 1 and 2.

The upwash at infinity is given by

$$\phi_z = \frac{1}{2\pi} \int_{h_1}^{h_2} \frac{(Y^2 - z^2) \Delta\phi_{TE}}{(Y^2 + z^2)^2} dy_1 \quad (42)$$

Integrating equation (42) by parts and replacing $\Delta\phi_{TE}$ by Γ gives

$$\phi_z = \frac{Y\Gamma}{2\pi(Y^2 + z^2)} \Big|_{h_1}^{h_2} - \frac{1}{2\pi} \int_{h_1}^{h_2} \frac{Y \frac{d\Gamma}{dy_1}}{Y^2 + z^2} dy_1 \quad (43)$$

For wings $\Gamma(h_1)$ and $\Gamma(h_2)$ are zero, the first term of equation (43) becomes zero, and the remaining term gives the upwash at infinity. The same result is given in reference 6.

The Upwash for a Flat Unswept Wing of Infinite Span

The $\Delta\phi_x$ on the plan form of an infinite unswept wing is $-\frac{2\alpha V}{\beta}$.

Since

$$\frac{\partial \Delta\phi_{x1}}{\partial y_1} = 0$$

equation (17) reduces to

$$\phi_z(x, y, 0) = -\alpha V$$

For points in the wake, equation (14) gives

$$\phi_z(x, y, 0) = 0$$

The preceding results are the well-known equations for the upwash in the $z = 0$ plane for the two-dimensional, flat, unswept wing.

Camber and Twist Necessary to Give Specified

Lift Distributions

Equation (17) may be used to find the camber and twist necessary to give a specified lift distribution. The local angle of attack is given by

$$\sigma = -\frac{\phi_z}{V} \quad (44)$$

and the pressure coefficient is given by

$$P = -\frac{2\Delta\phi_{x_1}}{V} \quad (45)$$

The local angle of attack for a given lift distribution, derived from equations (17), (44), and (45), is

$$\sigma = -\frac{\beta P}{4} - \frac{1}{4\pi} \oint_{MC} \frac{PR}{YX} dx_1 - \frac{1}{4\pi} \iint_T \frac{\frac{\partial P}{\partial y_1} R}{YX} dx_1 dy_1 \quad (46)$$

As an example, the local angle of attack of a rectangular wing with constant load is now considered.

When the pressure distribution is a constant, equation (46) becomes

$$\sigma = -\frac{\beta P}{4} - \frac{P}{4\pi} \oint_{MC} \frac{R}{YX} dx_1 \quad (47)$$

For the rectangular wing in the region unaffected by the tip, equation (47) becomes

$$\sigma = -\frac{\beta P}{4} \quad (48)$$

In the region affected by the tip, equation (47) becomes

$$\sigma = -\frac{\beta P}{4} - \frac{P}{4\pi y} \int_{x+\beta y}^0 \frac{\sqrt{(x-x_1)^2 - \beta^2 y_1^2}}{(x-x_1)} dx_1 \quad (49)$$

where the coordinates are now located at the intersection of the leading edge and the tip. (See fig. 10.) After the integration is performed equation (49) becomes

$$\sigma = \frac{P}{4\pi} \left(-\frac{\pi\beta}{2} + \frac{\sqrt{x^2 - \beta^2 y^2}}{y} + \beta \tan^{-1} \frac{\beta y}{\sqrt{x^2 - \beta^2 y^2}} \right) \quad (50)$$

Equation (50) agrees with the results in reference 10.

Upwash Close to the Trailing Edge

The value of the vertical perturbation velocity immediately behind the trailing edge can be obtained from equation (17).

In this application the concept of cancellation of pressure is utilized. It is assumed that the wing extends past the trailing edge. Since the pressure must be zero through the wake, this pressure behind the trailing edge must be canceled. The boundary conditions in the wake are then satisfied by the wing pressure extended past the trailing edge and the cancellation pressure. The upwash is therefore made up of the effect of the pressure on the wing, its extension behind the wing, and the cancellation of the pressure behind the trailing edge.

For trailing edges which are perpendicular to the free-stream direction the application of equation (17) (using the cancellation-of-pressure concept) to the upwash immediately behind the trailing edge leads directly to the relation

$$(\phi_z)_{TE} = -\sigma_{TE}V + \frac{\beta}{2}(\Delta\phi_x)_{TE} \quad (51)$$

where σ_{TE} is the local angle of attack of the wing at the trailing edge. The result given by equation (51) was obtained in references 1 and 2 from a physical consideration. When the trailing edge has a slope m , equation (17) yields

$$(\phi_z)_{TE} = -\sigma_{TE}V + \frac{(\Delta\phi_x)_{TE} \sqrt{\beta^2 m^2 - 1}}{2m} \quad (52)$$

Equation (52) is also obtained in reference 1.

Upwash in the Wake behind a Rectangular Wing

Pitching about Its Leading Edge

As an example to illustrate downwash calculations the upwash in the plane of the wing from a rectangular-pitching-wing is now calculated. (See fig. 10 for axes used in analysis.) For stationary axes a pitching wing moves in the arc of a circle; therefore, for axes fixed in the wing a pitching wing in linearized flow can be replaced by a wing which has a local angle of attack that varies linearly in the free-stream direction. It is assumed that the wake remains in the $z = 0$ plane and that the rolling-up of the trailing vortices can be neglected.

The wake behind a rectangular wing may be divided into two regions. One region is not affected by the tip or tips and is therefore a region which has a two-dimensional flow. The other region is the region affected by the tip or tips; in this region the flow is three-dimensional.

There is no upwash in the wake behind a two-dimensional unswept, pitching wing; therefore, only the region affected by the tips of the wing has upwash. Since the analysis is based on linearized flow, the two tip effects add directly and therefore only one tip need be treated.

The upwash in the $z = 0$ plane due to one tip of a rectangular pitching wing is shown in figures 10 and 11. The velocity potential and the pressure on a rectangular wing pitching about the leading edge were obtained by transforming the expressions given in reference 12 for the velocity potential and the pressure on a rectangular wing pitching about the half-chord line.

The upwash at the trailing edge was found by using equation (51). The upwash close to the trailing edge was found by use of equation (17). The evaluations of the integrals were performed numerically. Equation (17) was derived to find the downwash on the plan form, but it may be used in the wake by applying the cancellation-of-pressure concept.

A lifting line was used for calculating the upwash 2 or more chords behind the trailing edge inasmuch as this method was found to be accurate to two decimal places in this region.

The upwash at infinity was found by using equation (43). At infinity the upwash in the $z = 0$ plane for $\beta = C = 1$ is given by the following expressions:

For $y > 0$

$$\phi_z = \frac{4q}{3\pi} \left[\frac{(y+1)^2}{\sqrt{y(y+1)}} - y - \frac{3}{2} \right] \quad (53a)$$

for $-1 < y < 0$

$$\phi_z = -\frac{4q}{3\pi} \left(y + \frac{3}{2} \right) \quad (53b)$$

for $y < -1$

$$\phi_z = -\frac{4q}{3\pi} \left[\frac{(y+1)^2}{\sqrt{y(y+1)}} + y + \frac{3}{2} \right] \quad (53c)$$

Approximation of the Upwash from a
Rectangular Pitching Wing

The calculation of the downwash from the rectangular pitching wing together with results of reference 6 indicates that, for regions some distance behind the trailing edge, lifting lines give very good approximations to the actual flow fields. In many cases it is simpler to use the approximation given by equation (38) than to use the exact lifting-line expression. The accuracy of equation (38) was investigated by calculating the upwash from an unbent lifting line and comparing the results with the results obtained using equation (38). The unbent lifting line used was one that approximates the flow from the pitching rectangular wing.

In figure 12 the values of the upwash from the exact and the approximate lifting lines are plotted. Ten equally spaced points across the tip region were used in the approximation. It can be seen that for this case in most regions the approximation yields results which are as reliable as the exact values. If greater accuracy is required, it should be remembered that the accuracy of the approximation increases as the number of points is increased.

Approximation to the Upwash from a
Bent Lifting Line

The approximation to the upwash from a bent lifting line given by equation (39) was used to find the downwash along the line $z = 0$, $y = 0$ behind a triangular wing as shown in figure 13. Figure 13 shows the values given by equation (39) for 10 points across the semispan, the exact lifting line, and the exact linearized solution. The values for the exact lifting line for this case were taken from reference 6 and the values of the exact linearized solution were taken from reference 3.

Figure 13 shows good agreement between the approximate and exact bent lifting lines. In general, the accuracy of the approximation will increase as the number of points used in the approximation is increased; therefore, it is expected that the difference between the exact and approximate expressions given in figure 13 could be decreased by increasing the number of points across the semispan.

Langley Aeronautical Laboratory
National Advisory Committee for Aeronautics
Langley Air Force Base, Va., April 12, 1950

APPENDIX

DIFFERENTIATION UNDER THE INTEGRAL SIGN

OF THE EXPRESSION FOR ϕ

The fact that equation (6) may be differentiated with respect to z under the integral sign without consideration of the variable limits can be proved as follows:

If it is assumed that the right side of equation (6) can be differentiated by differentiating only the integrand, then

$$\phi_z = \frac{1}{2\pi} \iint_{\tau} \frac{\Delta\phi_x \left[(Y^2 - z^2)R^2 + \beta^2 z^2 (Y^2 + z^2) \right] X}{(Y^2 + z^2)^2 R^3} dx_1 dy_1 \quad (A1)$$

If the preceding equation is correct, the potential may be expressed by

$$\phi = \frac{1}{2\pi} \int_{-\infty}^z \iint_{\tau} \frac{\Delta\phi_x \left[(Y^2 - \lambda^2)R^2 + \beta^2 \lambda^2 (Y^2 + \lambda^2) \right] X}{(Y^2 + \lambda^2)^2 [R(\lambda)]^3} dx_1 dy_1 d\lambda \quad (A2)$$

since

$$\phi = \int_{-\infty}^z \phi_z(x, y, \lambda) d\lambda$$

Interchanging the order of integration of equation (A2) yields

$$\phi = \frac{1}{2\pi} \iint_{\tau} \Delta\phi_x \int_{-\infty}^z \frac{\left[(Y^2 - \lambda^2) [R(\lambda)]^2 + \beta^2 \lambda^2 (Y^2 + \lambda^2) \right] X}{(Y^2 + \lambda^2)^2 [R(\lambda)]^3} d\lambda dx_1 dy_1 \quad (A3)$$

The result of performing the first integration in equation (A3) is

$$\phi = \frac{1}{2\pi} \iint_{\tau} \frac{\Delta\phi_x zX}{(Y^2 + z^2)^R} dx_1 dy_1 \quad (A4)$$

Equation (A4) is the same as equation (6); therefore, it has been shown that equation (6) may be differentiated with respect to z under the integral sign without regard to the variable limits. Similar proof for the other velocity components can also be obtained.

REFERENCES

1. Lagerstrom, P. A., Graham, Martha E., and Grosslight, G.: Downwash and Sidewash Induced by Three-Dimensional Lifting Wings in Supersonic Flow. Rep. No. SM-13007, Douglas Aircraft Co., Inc., April 14, 1947.
2. Heaslet, Max. A., and Lomax, Harvard: The Calculation of Downwash behind Supersonic Wings with an Application to Triangular Plan Forms. NACA TN 1620, 1948.
3. Lomax, Harvard, and Sluder, Loma: Downwash in the Vertical and Horizontal Planes of Symmetry behind a Triangular Wing in Supersonic Flow. NACA TN 1803, 1949.
4. Robinson, A.: On source and Vortex Distributions in the Linearized Theory of Steady Supersonic Flow. Rep. No. 9, College of Aero. (Cranfield), Oct. 1947.
5. Robinson, A., and Hunter-Tod, J. H.: Bound and Trailing Vortices in the Linearized Theory of Supersonic Flow, and the Downwash in the Wake of a Delta Wing. Rep. No. 10, College of Aero. (Cranfield), Oct. 1947.
6. Mirels, Harold, and Haefeli, Rudolph C.: Line-Vortex Theory for Calculation of Supersonic Downwash. NACA TN 1925, 1949.
7. Ward, G. N.: Calculation of Downwash behind a Supersonic Wing. The Aeronautical Quarterly, vol. 1, pt. I, May 1949, pp. 35-38.
8. Hadamard, Jacques: Lectures on Cauchy's Problem in Linear Partial Differential Equations. Yale Univ. Press (New Haven), 1923.
9. Heaslet, Max. A., and Lomax, Harvard: The Use of Source-Sink and Doublet Distributions Extended to the Solution of Boundary-Value Problems in Supersonic Flow. NACA Rep. 900, 1948.
10. Heaslet, Max. A., Lomax, Harvard, and Jones, Arthur L.: Volterra's Solution of the Wave Equation as Applied to Three-Dimensional Supersonic Airfoil Problems. NACA Rep. 889, 1947.
11. Schlichting, H.: Airfoil Theory at Supersonic Speed. NACA TM 897, 1939.
12. Harmon, Sidney M.: Stability Derivatives at Supersonic Speeds of Thin Rectangular Wings with Diagonals ahead of Tip Mach Lines. NACA Rep. 925, 1949.

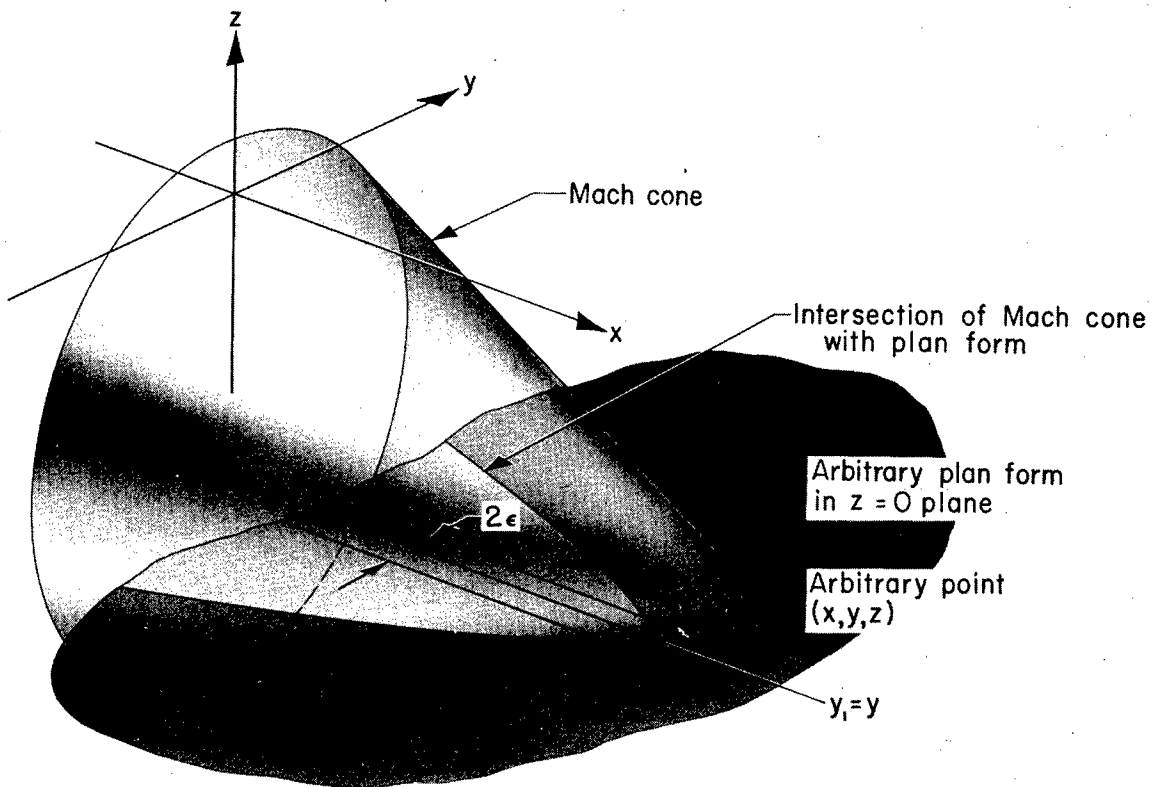

(a) Arbitrary point above plan form.

NACA
L-64103.1

Figure 1.- The intersection of forward Mach cone from point (x, y, z) with arbitrary plan form.

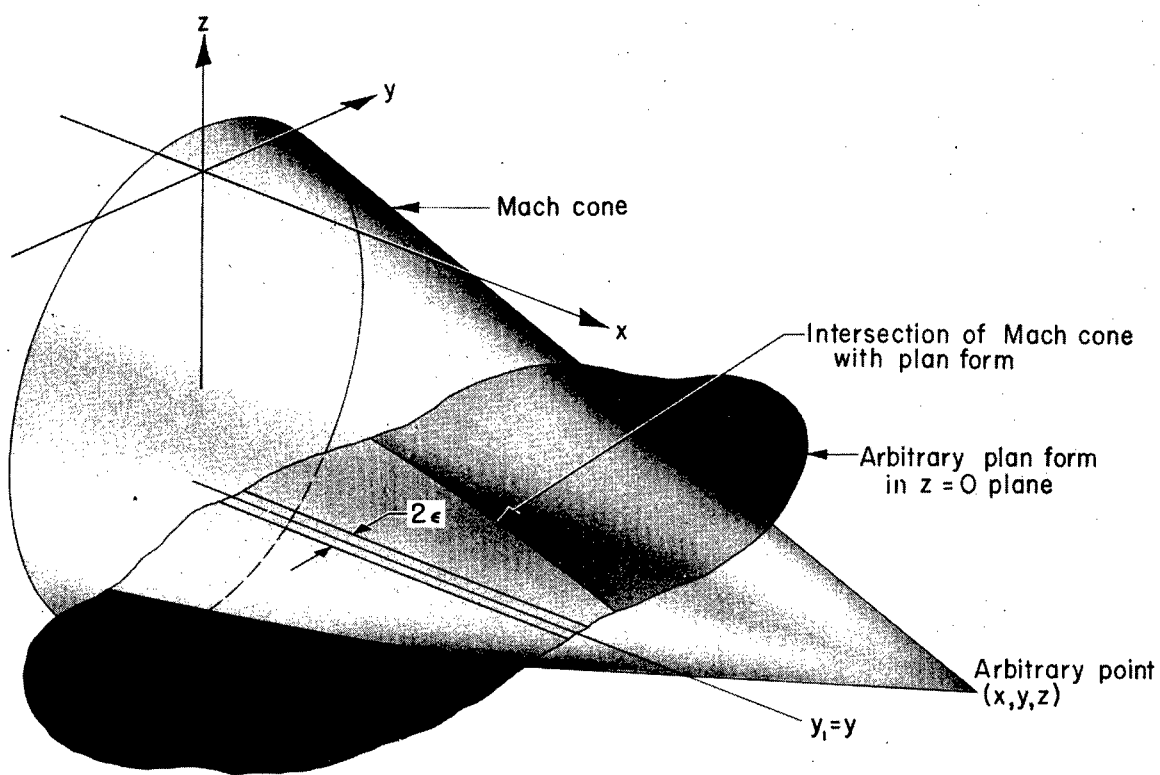

(b) Arbitrary point above wake.

NACA
L-64104.1

Figure 1.- Concluded.

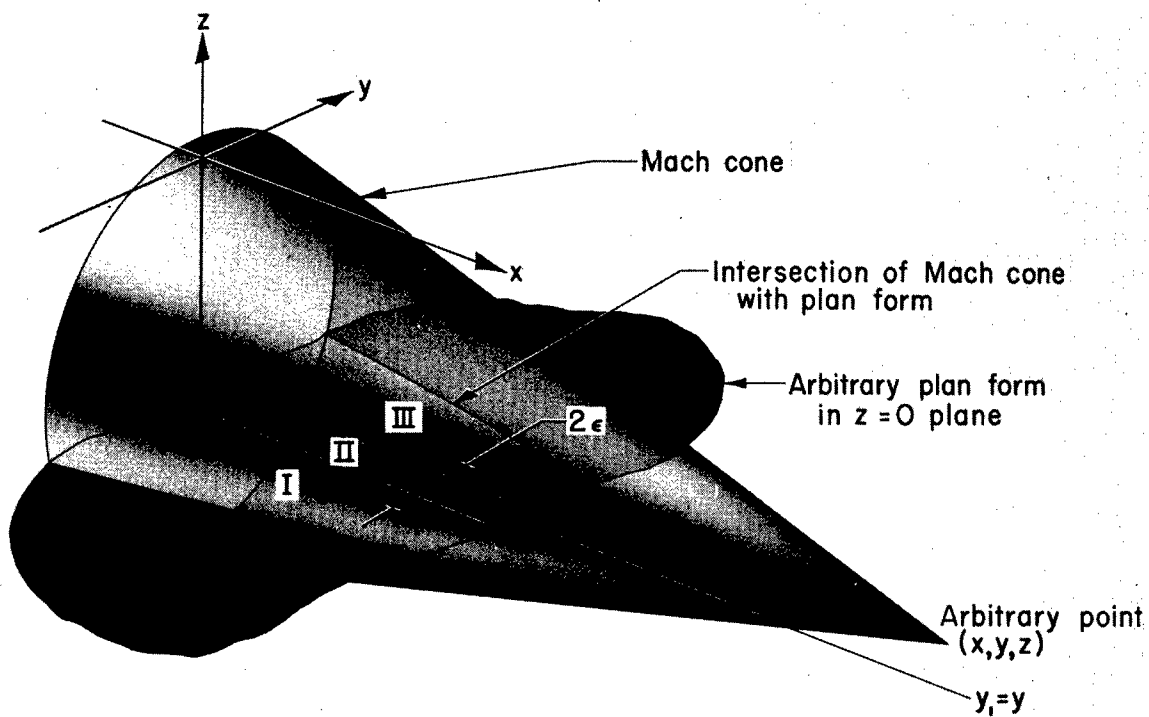

NACA
L-64105.1

Figure 2.- Regions of integration for a point affected by the wake.

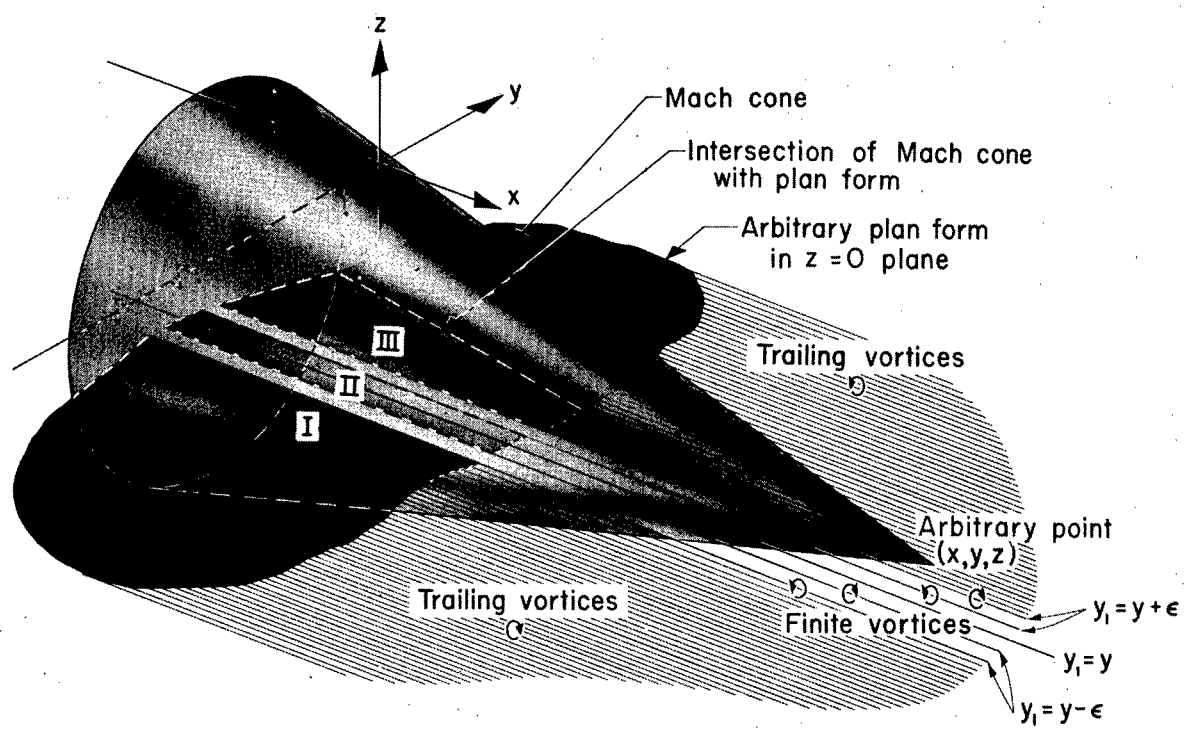

NACA
L-64106.1

Figure 3.- Vortices associated with the regions of integration.

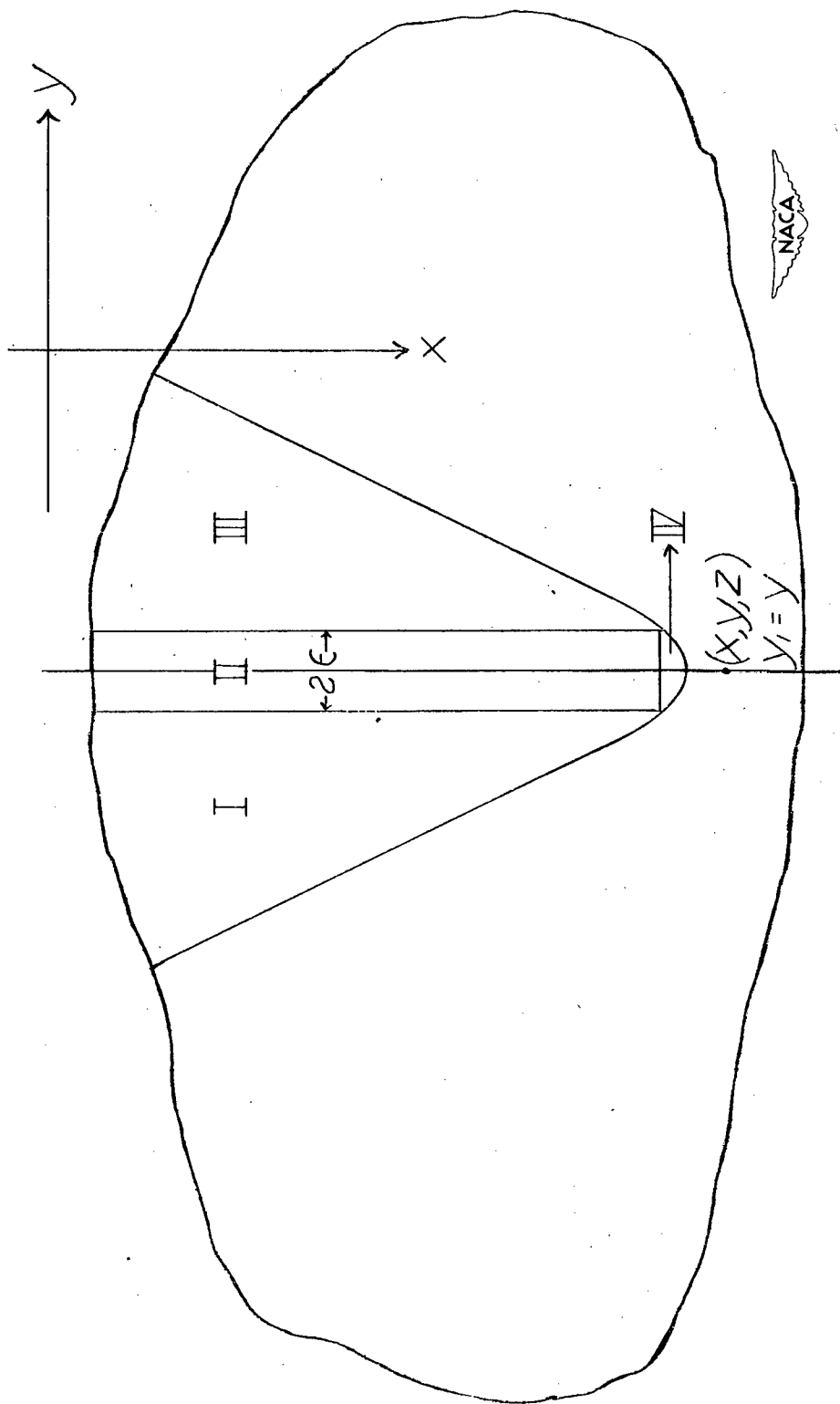
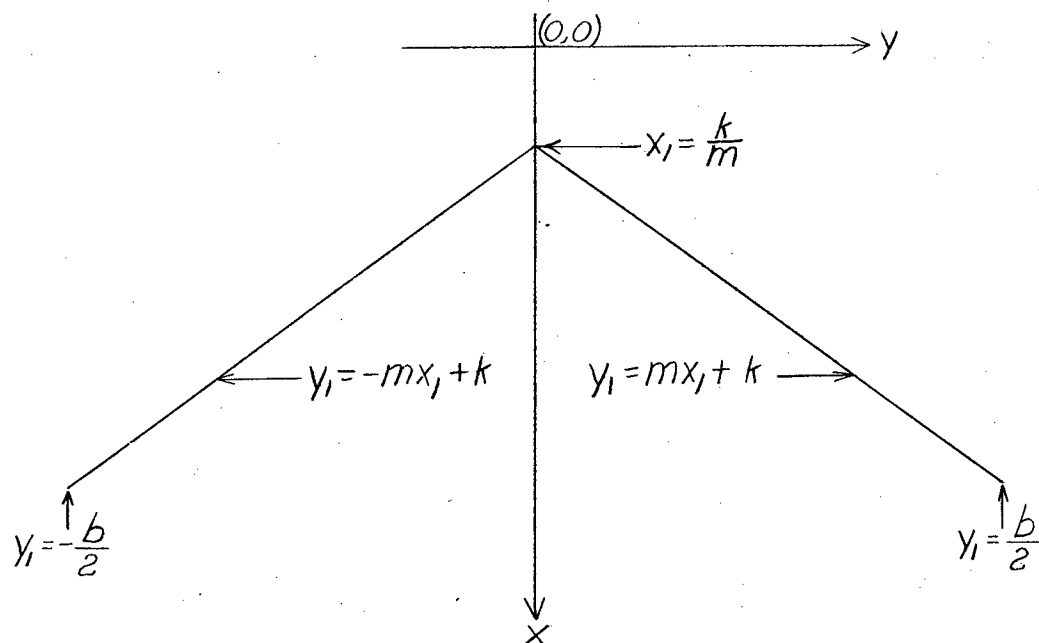
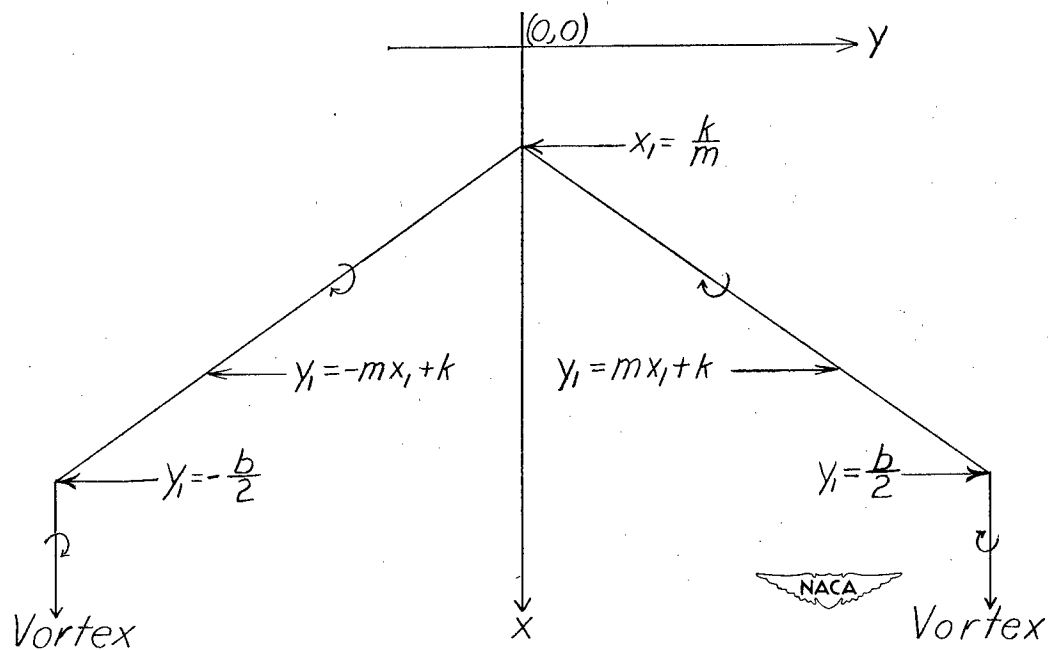

Figure 4.- Top view of regions of integration used in finding the downwash on the plan form.



(a) Bent lifting line.



(b) Vortex of constant strength.

Figure 5.- Lifting line of constant slope.

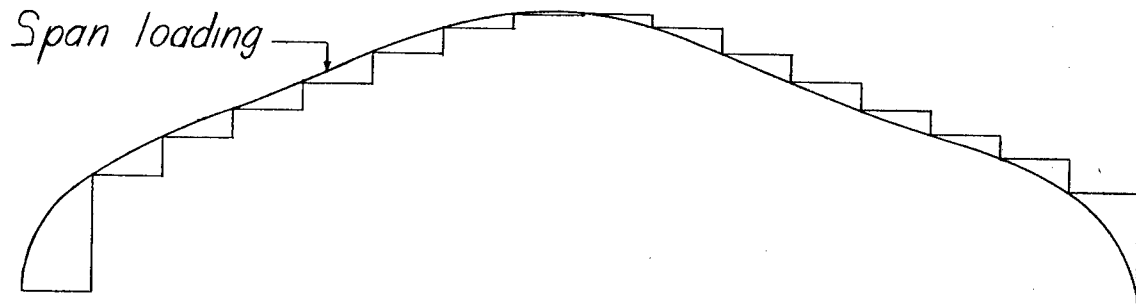

(a) Approximation that leads to equation (36).

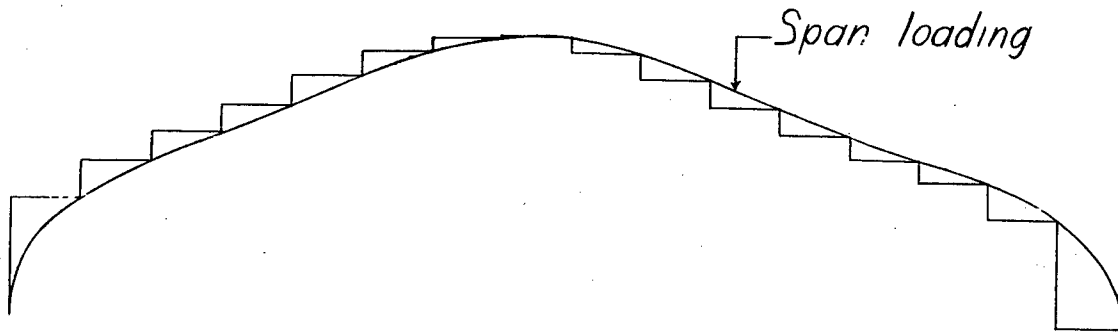

(b) Approximation that leads to equation (37).

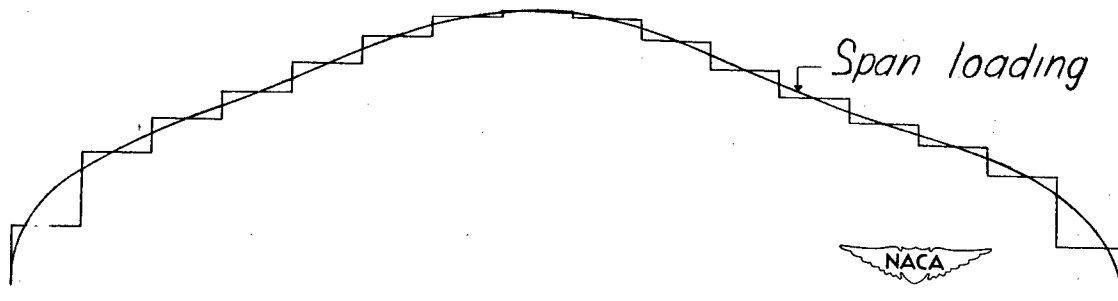

(c) Approximation that leads to equation (38).

Figure 6.- Approximations of the span loading by series of rectangles.

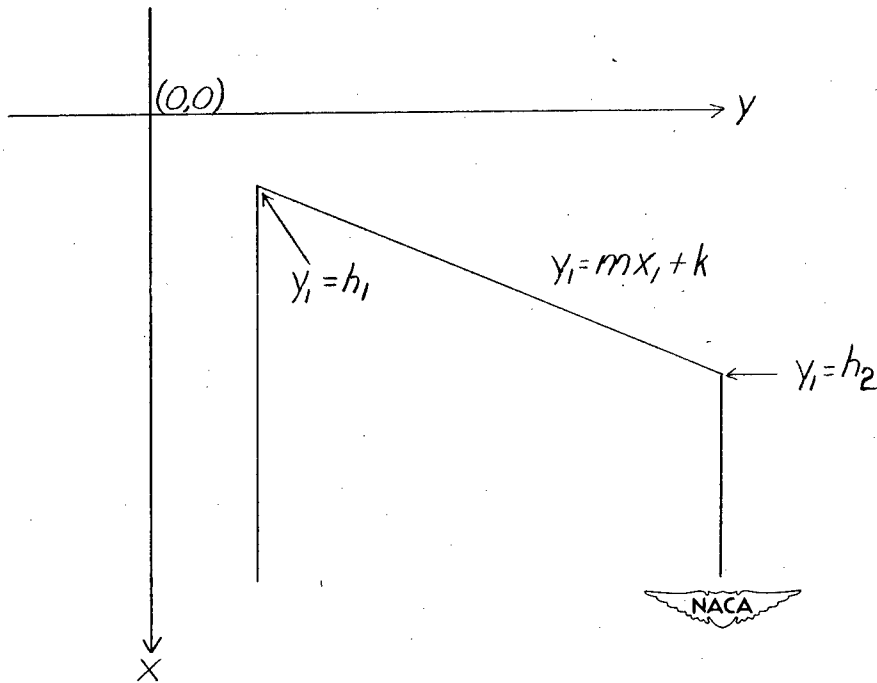

Figure 7.- Finite vortex of the form used to approximate a bent lifting line.

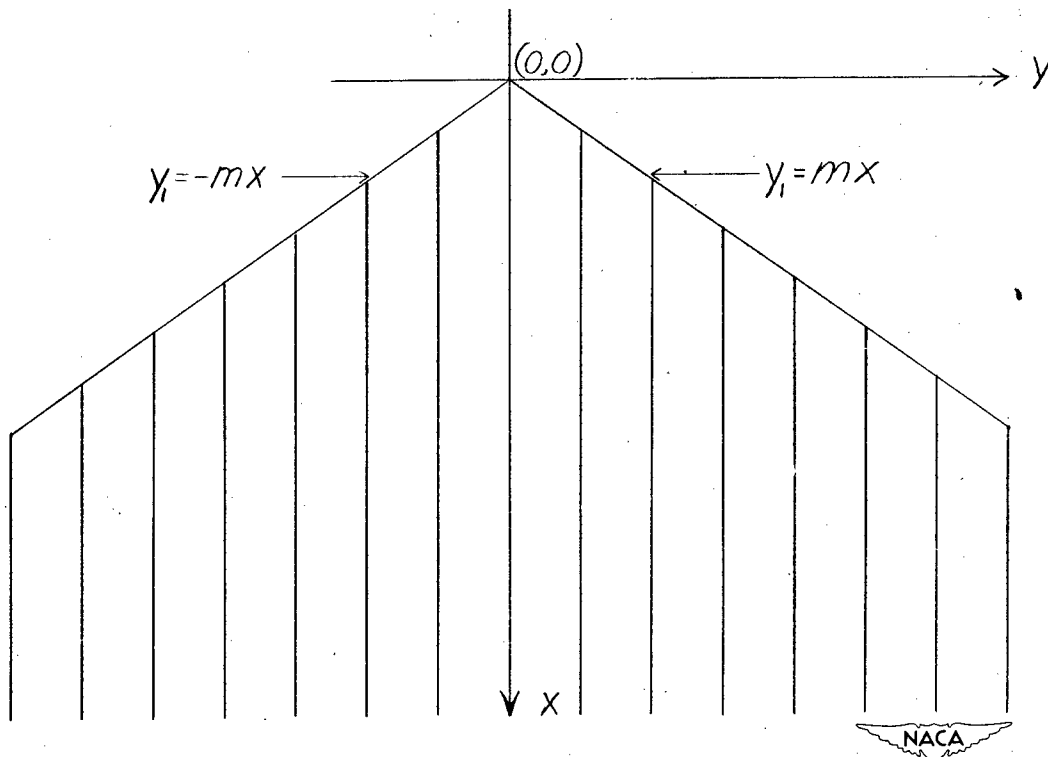
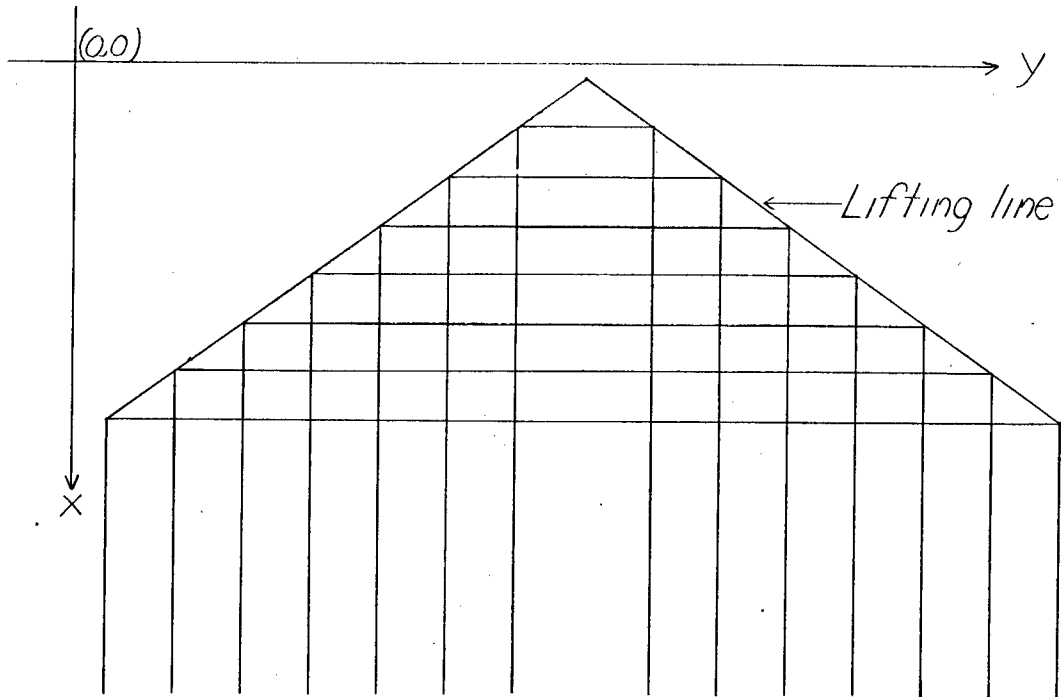
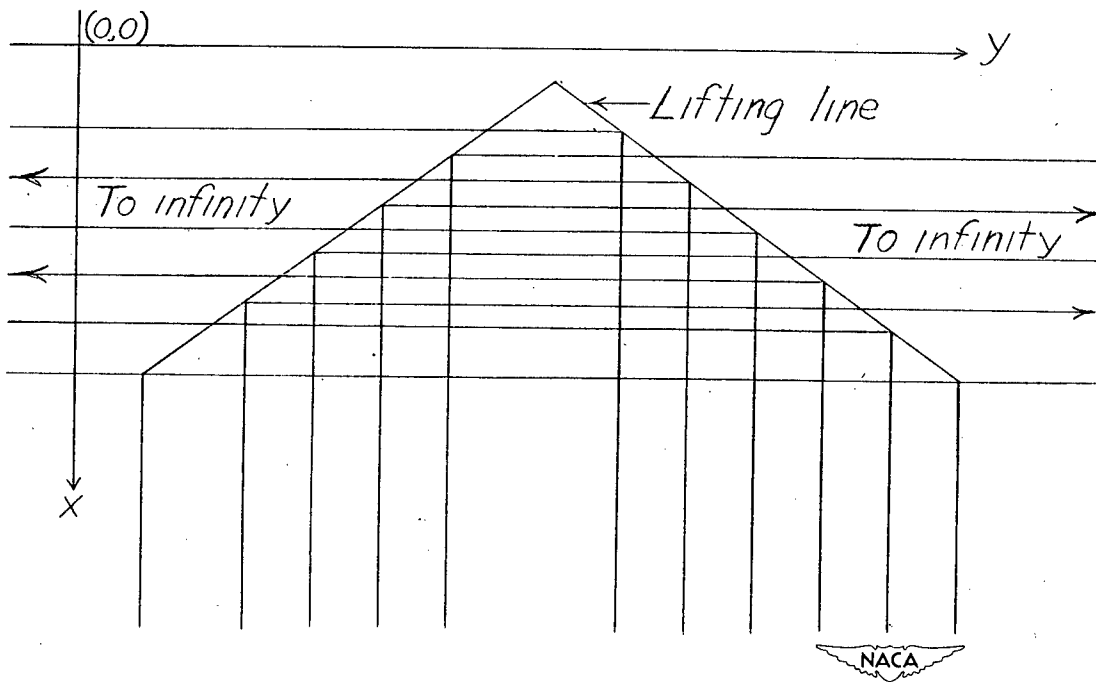

Figure 8.- Bent lifting line approximated by a series of finite vortices.



(a) Symmetrical loading and symmetrically distributed points.



(b) Unsymmetrical loading and/or unsymmetrically distributed points.

Figure 9.- Bent lifting lines approximated by a series of horseshoe vortices.

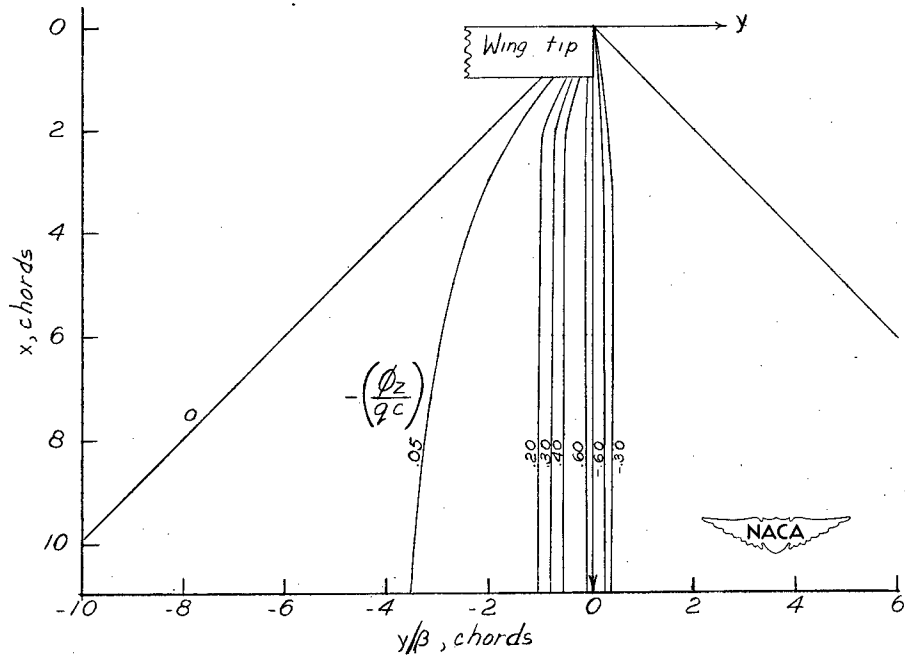

Figure 10.- Contour plot of the downwash from a pitching rectangular wing in $z = 0$ plane.

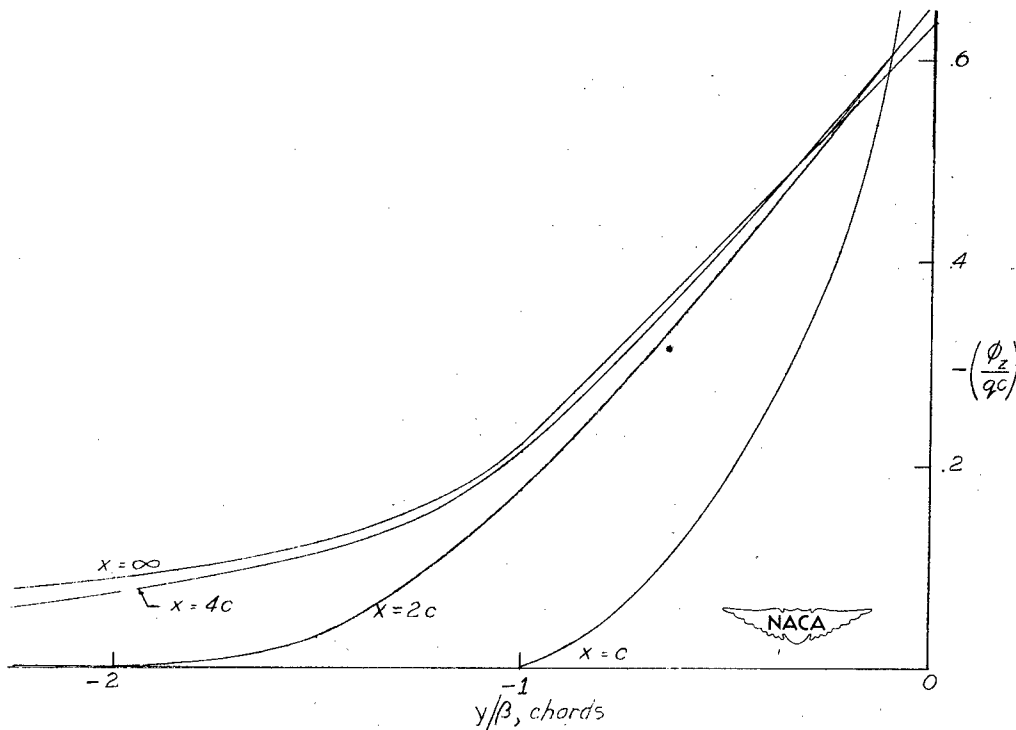

Figure 11.- Downwash behind a pitching rectangular wing in $z = 0$ plane.

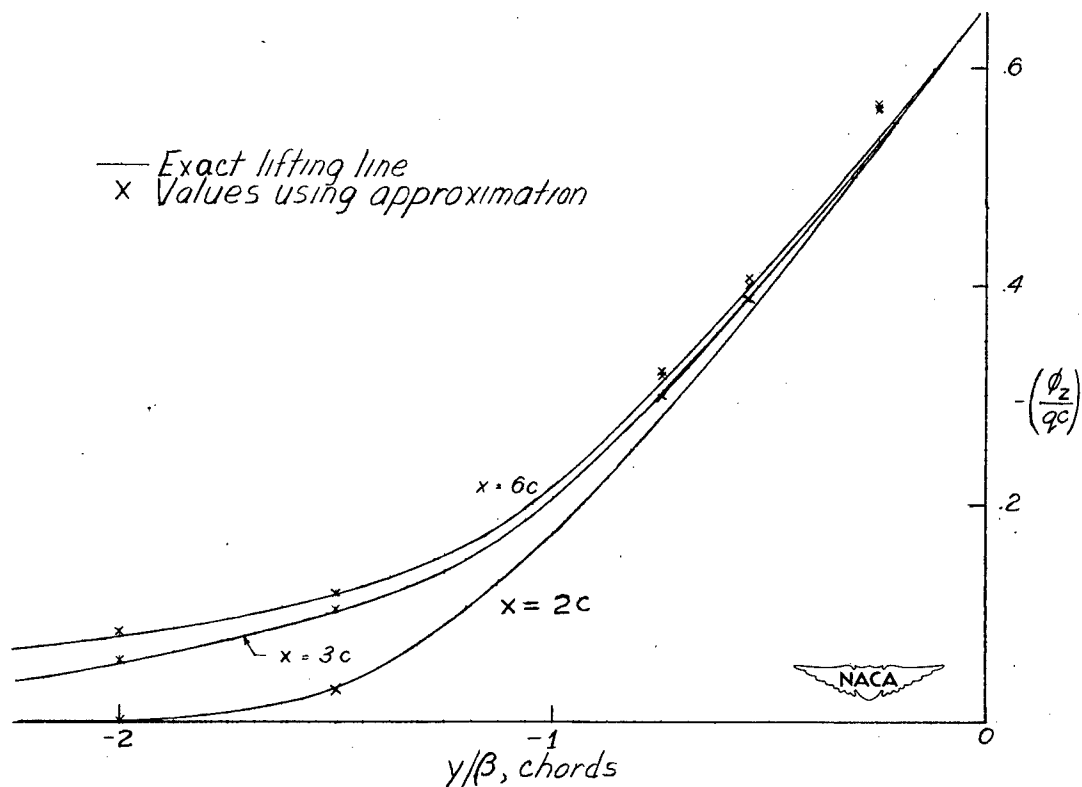

Figure 12.- Downwash from a lifting line and its approximation by a series of horseshoe vortices at ten equally spaced points. (Lifting line approximates a rectangular pitching wing.)

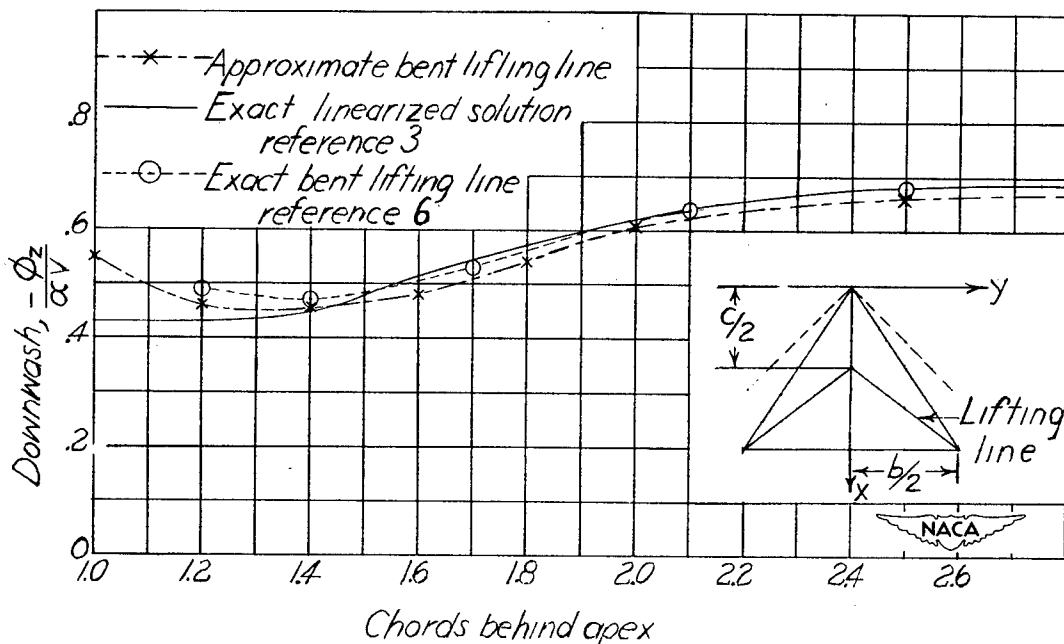

Figure 13.- Downwash determined by exact and approximate lifting lines along the line $z = 0, y = 0$ behind a triangular wing with aspect ratio of 3.2. $M = \sqrt{2}$.