

NATIONAL ADVISORY COMMITTEE FOR AERONAUTICS

TECHNICAL NOTE

No. 1518

STRUCTURAL EVALUATION OF AN EXTRUDED

MAGNESIUM-ALLOY T-STIFFENED PANEL

By Norris F. Dow and William A. Hickman

Langley Memorial Aeronautical Laboratory
Langley Field, Va.



Washington

February 1948

DISTRIBUTION STATEMENT A
Approved for Public Release
Distribution Unlimited

Reproduced From
Best Available Copy

20000807 140

NATIONAL ADVISORY COMMITTEE FOR AERONAUTICS

TECHNICAL NOTE NO. 1518

STRUCTURAL EVALUATION OF AN EXTRUDED
MAGNESIUM-ALLOY T-STIFFENED PANEL

By Norris F. Dow and William A. Hickman

SUMMARY

Compressive tests were made of six different lengths of a ZK60A magnesium-alloy flat panel having skin and longitudinal T-section stiffeners extruded as one integral unit. The results indicated that the extruded panel had structural characteristics which were somewhere between those for 24S-T and those for 75S-T aluminum-alloy Y-stiffened panels but, because of the integral nature of the extruded construction, required far fewer rivets to assemble than either the 24S-T or the 75S-T panels with which comparisons were made. The height of the stiffeners was also somewhat less for the extruded panel.

INTRODUCTION

The conventional method of riveting stiffeners to the skin on wing compression panels is costly, tends to roughen the outside surface of the skin, and tends to introduce an element of uncertainty regarding the panel strength, especially on short panels for which the panel strength is dependent on the diameter and the pitch of the rivets. (See reference 1.) An integral construction for skin and stiffeners, which can be obtained by the extrusion of the entire panel, offers possibilities of avoiding some of these objections to riveting.

Charts for the calculation of the critical compressive stress for such extruded panels were presented in reference 2. Extrusions of ZK60A magnesium alloy having proportions based on these charts have been made by the Dow Chemical Company. The present paper is concerned with the results of compressive tests on these extrusions.

SYMBOLS

L length of panel, inches
 ρ radius of gyration, inches
 σ_{cy} compressive yield stress, ksi

σ_{cr}	stress for local buckling, ksi
$\bar{\epsilon}_f$	unit shortening at failing load
P_i	compressive load per inch of panel width, kips per inch
c	coefficient of end fixity as used in Euler column formula
η	nondimensional coefficient that takes into account reduction in modulus of elasticity for stresses beyond elastic range; within elastic range, $\eta = 1$
$\bar{\sigma}_f$	average stress at failing load, ksi
$\bar{\sigma}_{f_{eq}}$	"equivalent" average stress at failing load, equal to failing load divided by cross-sectional area of a 24S-T aluminum-alloy panel of same weight per unit length as panel in question, ksi
\bar{h}	distance from outside surface of sheet to axis of center of gravity of panel, inches
E	Young's modulus, ksi
I_i	moment of inertia per inch of panel width, cubic inches
A_i	cross-sectional area per inch of panel width, inches
$\sigma_{cr_{eq}}$	"equivalent" stress for local buckling equal to load for local buckling divided by cross-sectional area of a 24S-T aluminum-alloy panel of same weight per unit length as panel in question, ksi
$A_{i_{eq}}$	"equivalent" area per inch of panel width, equal to cross-sectional area per inch of width of a 24S-T aluminum-alloy panel of same weight per unit length as panel in question, inches
H	over-all height of stiffeners, measured from inside surface of sheet, inches
S	average spacing of rivet lines, inches
b_s	stiffener spacing of ZK60A magnesium-alloy panel, inches
t_s	thickness of skin, inches
b_w	width of web of stiffener, inches
t_w	thickness of web of stiffener, inches

- b_F over-all width of outstanding flange of stiffener, inches
- t_F thickness of outstanding flange of stiffener, inches

TEST SPECIMENS AND METHOD OF TESTING

The test panels were constructed by riveting together three widths of extrusion and milling off the outstanding parts of the skin to obtain the cross section shown in figure 1. Seven test specimens having six different lengths were used. The nominal values of the slenderness ratio L/ρ were 20, 35, 55, 80, 110, and 150; a duplicate of the panel having $L/\rho = 35$ was also tested. Test specimens after failure are shown as figure 2.

The material properties of the ZK60A magnesium alloy of which the extrusions were made were determined by the manufacturer from specimens cut from the various locations indicated in figure 3. These properties are listed in table 1. A few specimens cut from the same locations and tested in the Langley structures research laboratory gave values of σ_{cy} which fell between the maximum and minimum values given in table 1. A stress-strain curve for an entire extrusion with the outstanding parts of the skin removed gave a value of σ_{cy} of 33.2 ksi.

The three sections of extrusion were riveted together with $\frac{3}{16}$ -inch diameter A17S-T flat-head rivets (AN442AD-6) at $\frac{9}{16}$ -inch pitch. Larger rivets were not used on account of the relatively small edge distance ($\frac{3}{8}$ in.) in the space provided for overlapping the extruded sections.

The method of testing was the same as that used in other panel tests in the Langley structures research laboratory. The panels were compressed flat-ended without side support in a hydraulic testing machine which has an accuracy of one-half of 1 percent of the load. The ends of the specimen were accurately ground flat and parallel in a special grinder, and the method of alignment in the testing machine was such as to insure uniform bearing on the ends of the specimen. A value of the end fixity coefficient of 3.75 has been indicated for such panel tests in this machine.

The stress for local buckling σ_{cr} was determined by the "strain-reversal method" on the two shortest panels. (See reference 3 for a discussion of this and other methods of experimentally determining σ_{cr} .) The unit shortening at failing load $\bar{\epsilon}_F$ was determined as the average of the strains indicated by four, $6\frac{1}{2}$ -inch gage length, resistance-type wire strain gages mounted at the quarter points along the length of the

second and fifth stiffeners near the axis of the center of gravity of the cross section. (See fig. 4 which shows the panel with $\frac{L}{\rho} = 55$ ready for test in the testing machine.)

RESULTS AND DISCUSSION

The test results are given in table 2 and values of $\bar{\sigma}_{feq}$ are plotted against the parameter $\frac{P_1}{L/\sqrt{C}}$ in figure 5. No correction has been made to the test results to take account of the fact that there was one more stiffener than bay on the test panel.

A critical stress for the panel was calculated from the charts of reference 2 to be approximately 26.6 ksi. In this calculation the secant modulus (as suggested in reference 4) was used to determine the effective modulus ηE from the stress-strain curve. (The curve for the entire cross section with the outstanding parts of the skin removed was used.) The calculated value of 26.6 ksi is in good agreement with the experimentally determined values of σ_{cr} for the two shortest panels. (See table 2.)

EVALUATION OF EXTRUDED PANEL

Because only one cross section of extruded panel was available for test, no design charts similar to those of references 5 and 6 can be prepared for this type of panel at present. In order to make some structural evaluation of the extruded panel, the "equivalent stresses" carried by the various lengths of extruded panel tested were therefore compared with those for minimum-weight designs of 24S-T and 75S-T aluminum-alloy Y-stiffened (riveted) panels. These minimum-weight designs were made to meet the loading conditions existing at failure for each length of extruded panel, and the skin thickness of the comparative designs was selected to give a shear stiffness approximately the same as that for the extruded panel. These stresses are compared in figure 6.

The equivalent stress is defined as the load divided by the area of a 24S-T aluminum-alloy panel of the same weight per unit length as the panel in question. Because the panels compared in figure 6 carry the same loads and have such areas that failure occurs at those loads, the stresses carried measure the cross-sectional areas and the equivalent stresses measure the panel weights. Accordingly, the higher the equivalent stress for a given load, the lighter in weight is the panel.

Figure 6 shows that the equivalent stress carried by the extruded panel is less than that for the 75S-T panels at all lengths but is greater than that for the 24S-T panels for all except the two greatest lengths. The greatest percentage increase in equivalent stress for the extruded panel over the corresponding 24S-T panel design occurs at the effective length L/\sqrt{c} of 39.2 inches.

Although the weight of the panel required to carry the compressive load may usually be considered of primary importance, other characteristics may also be important for particular applications. For example, a small distance \bar{h} between the axis of the center of gravity of the panel and the skin surface becomes more important as the wing thickness is decreased. A high bending stiffness of the cross section EI_1 for a given rib spacing becomes more important as the local air loads increase relative to the compression loads. A high buckling load $\sigma_{cr}A_1$ or $\sigma_{creq}A_{1eq}$ becomes more important as greater emphasis is placed on smooth wing surfaces. A small height of stiffeners H becomes more important as more space is required in the wing for cargo or fuel. A wide average spacing of rivet lines S to keep the number of rivets to a minimum, on the other hand, is always important.

Figure 7 was prepared to compare the weight, and the other characteristics just described, of the extruded ZK60A magnesium-alloy panel and the 24S-T and 75S-T aluminum-alloy Y-stiffened-panel designs at the effective length indicated in figure 6 to be most favorable to the extruded panel. The comparisons show that, for the extruded panel,

(1) A_{1eq} is 7.6 percent more than for the 75S-T aluminum-alloy Y-stiffened panel and 9.7 percent less than for the 24S-T panel

(2) \bar{h} is 18.7 percent more than for the 75S-T panel and 6.3 percent less than for the 24S-T panel

(3) EI_1 is 6.9 percent more than for the 75S-T panel and 35.6 percent less than for the 24S-T panel

(4) $\sigma_{creq}A_{1eq}$ is 26.8 percent more than for the 75S-T panel and 3.0 percent less than for the 24S-T panel

(5) H is 3.4 percent less than for the 75S-T panel and 16.6 percent less than for the 24S-T panel

(6) S is 416 percent more than for the 75S-T panel and 410 percent more than for the 24S-T panel

The characteristic for which the extruded panel has the most substantial advantage, as shown in figure 7, is the smaller number of rivets that are required on account of the wider average spacing of the rivet lines S . The height of the stiffeners H is shown to be

somewhat less for the extruded panel. All the other characteristics of the extruded panel considered are somewhere between those for 24S-T and those for 75S-T aluminum-alloy Y-stiffened panels.

CONCLUDING REMARKS

Compressive tests of six lengths of an extruded ZK60A magnesium-alloy panel indicated that the particular cross section tested at best had a structural efficiency somewhere between that for 24S-T and that for 75S-T aluminum-alloy Y-stiffened panels but, because of the integral nature of the extruded construction, required far fewer rivets to assemble than either the 24S-T or the 75S-T panels with which comparisons were made. The height of the stiffeners was also somewhat less for the extruded panel.

The comparisons made, however, were only for the one cross section tested. Whether other proportions of the extruded panel, as might be required for a particular application in actual construction, would show similar characteristics can hardly be predicted from such a limited series of tests. Such a prediction could be made if design charts similar to those of references 5 and 6 were prepared for extruded panels. The characteristics of the one cross section tested appear sufficiently promising to make the preparation of such charts desirable as soon as a wide enough range of proportions of extruded panels becomes available.

Langley Memorial Aeronautical Laboratory
National Advisory Committee for Aeronautics
Langley Field, Va. September 25, 1947

REFERENCES

1. Dow, Norris F., and Hickman, William A.: Effect of Variation in Diameter and Pitch of Rivets on Compressive Strength of Panels with Z-Section Stiffeners. I - Panels with Close Stiffener Spacing That Fail by Local Buckling. NACA RB No. L5G03, 1945.
2. Boughan, Rolla B., and Baab, George W.: Charts for Calculation of the Critical Compressive Stress for Local Instability of Idealized Web- and T-Stiffened Panels. NACA ARR No. L4H29, 1944.
3. Hu, Pai C., Lundquist, Eugene E., and Batdorf, S. B.: Effect of Small Deviations from Flatness on Effective Width and Buckling of Plates in Compression. NACA TN No. 1124, 1946.
4. Heimerl, George J.: Determination of Plate Compressive Strengths. NACA TN No. 1480, 1947.
5. Dow, Norris F., and Hickman, William A.: Design Charts for Flat Compression Panels Having Longitudinal Extruded Y-Section Stiffeners and Comparison with Panels Having Formed Z-Section Stiffeners. NACA TN No. 1389, 1947.
6. Schuette, Evan H.: Charts for the Minimum-Weight Design of 24S-T Aluminum-Alloy Flat Compression Panels with Longitudinal Z-Section Stiffeners. NACA ARR No. L5F15, 1945.

TABLE 1.- VALUES OF THE COMPRESSIVE YIELD STRESS FOR
THE SPECIMENS CUT FROM THE EXTRUDED SECTIONS

Location (see fig. 3)	σ_{cy} (ksi)		
	Maximum	Average	Minimum
A	34.6	32.5	31.3
B	34.2	32.7	30.6
C	39.4	38.0	35.0
D	37.6	33.5	30.6
E	40.6	39.1	37.3

NACA

TABLE 2.- DIMENSIONS AND TEST DATA FOR TEST SPECIMENS
[Nominal dimensions are given in parentheses]

L	Dimensions (in.)							Test data				
	b_s	t_s	b_w	t_w	b_p	t_p	$\bar{\sigma}_f$ (ksi)	σ_{or} (ksi)	P_1 L/\bar{c} (ksi)	ϵ_f		
18.77	(3.08)	(0.1100)	(2.28)	(0.1100)	(0.91)	(0.1600)	29.1	26.5	0.712	0.00533		
32.86	3.08	0.0971	2.25	0.1080	0.92	0.1623	27.4	25.4	.380	.00494		
33.24	3.10	.0962	2.24	.1084	.91	.1626	28.5	-----	.396	-----		
53.48	3.10	.1012	2.25	.1099	.92	.1629	26.3	-----	.232	.00440		
76.00	3.08	.1014	2.26	.1115	.90	.1639	24.3	-----	.147	.00392		
104.62	3.09	.0994	2.26	.1101	.91	.1615	18.4	-----	.080	.00232		
142.55	3.08	.0981	2.26	.1066	.90	.1615	10.6	-----	.035	.00164		
	3.10	.1033	2.26	.1068	.91	.1632						

NACA

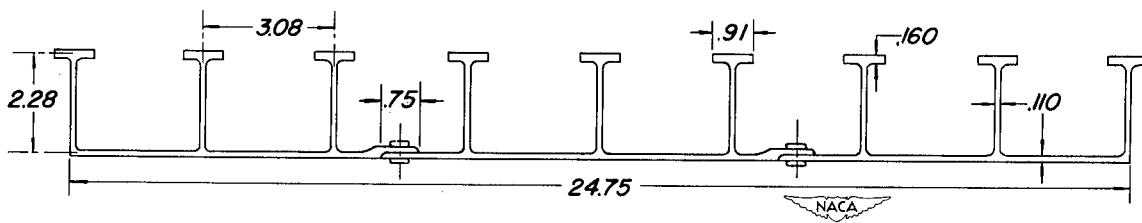

Figure 1.—Cross section of test specimens.

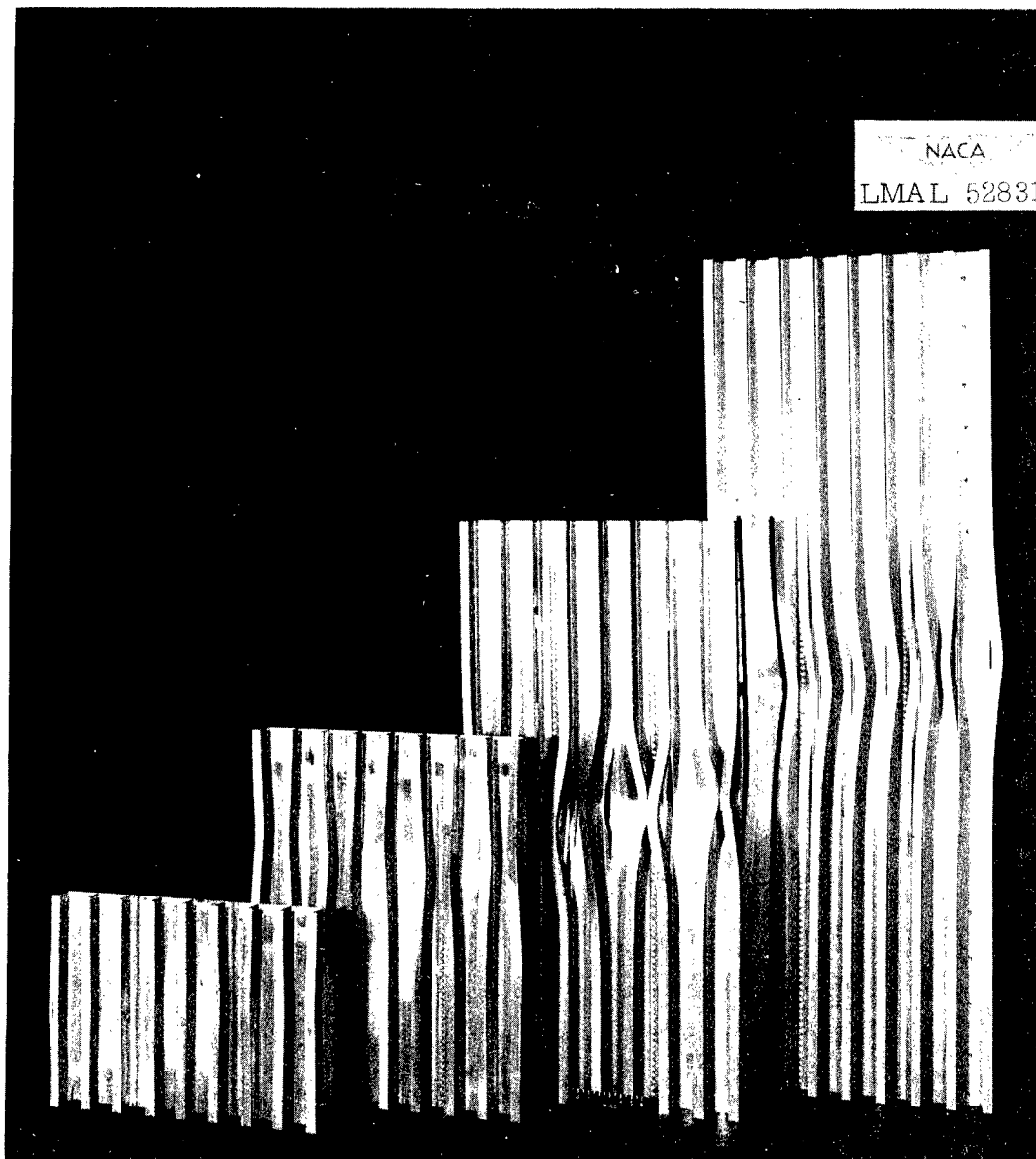

Figure 2.- Tested specimens having L/ρ of 20, 35, 55, and 80.

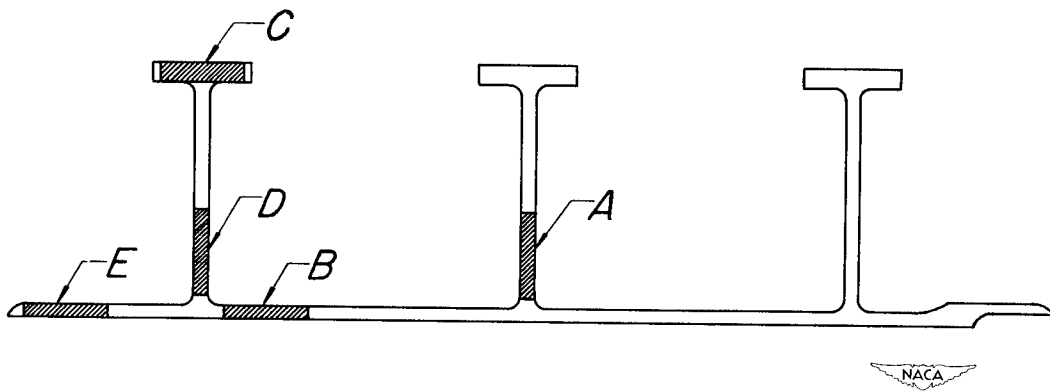

Figure 3.—Locations from which stress-strain specimens were cut from extruded sections. (See table I.)

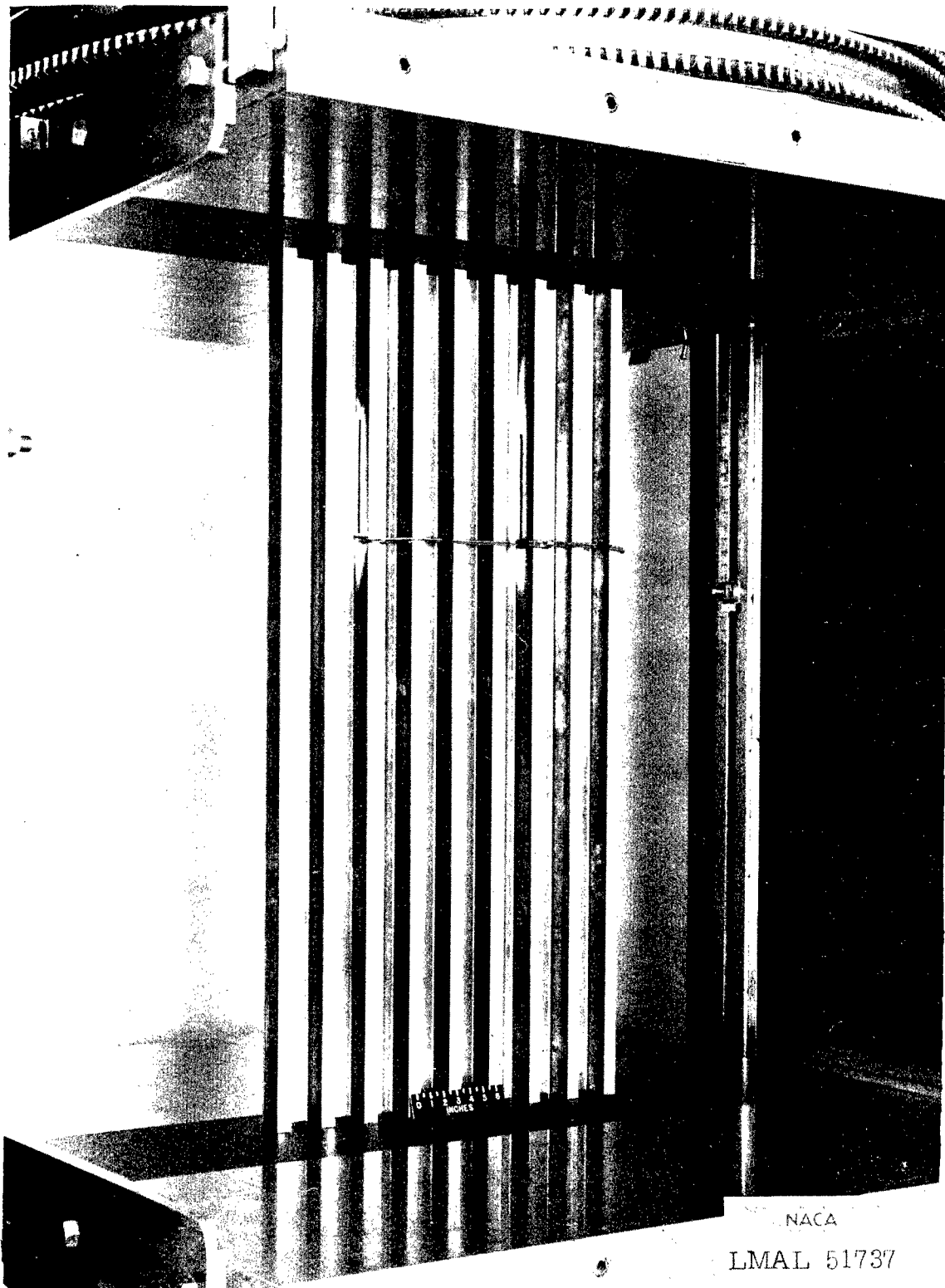

Figure 4.- Test specimen in testing machine. $\frac{L}{p} = 55.$

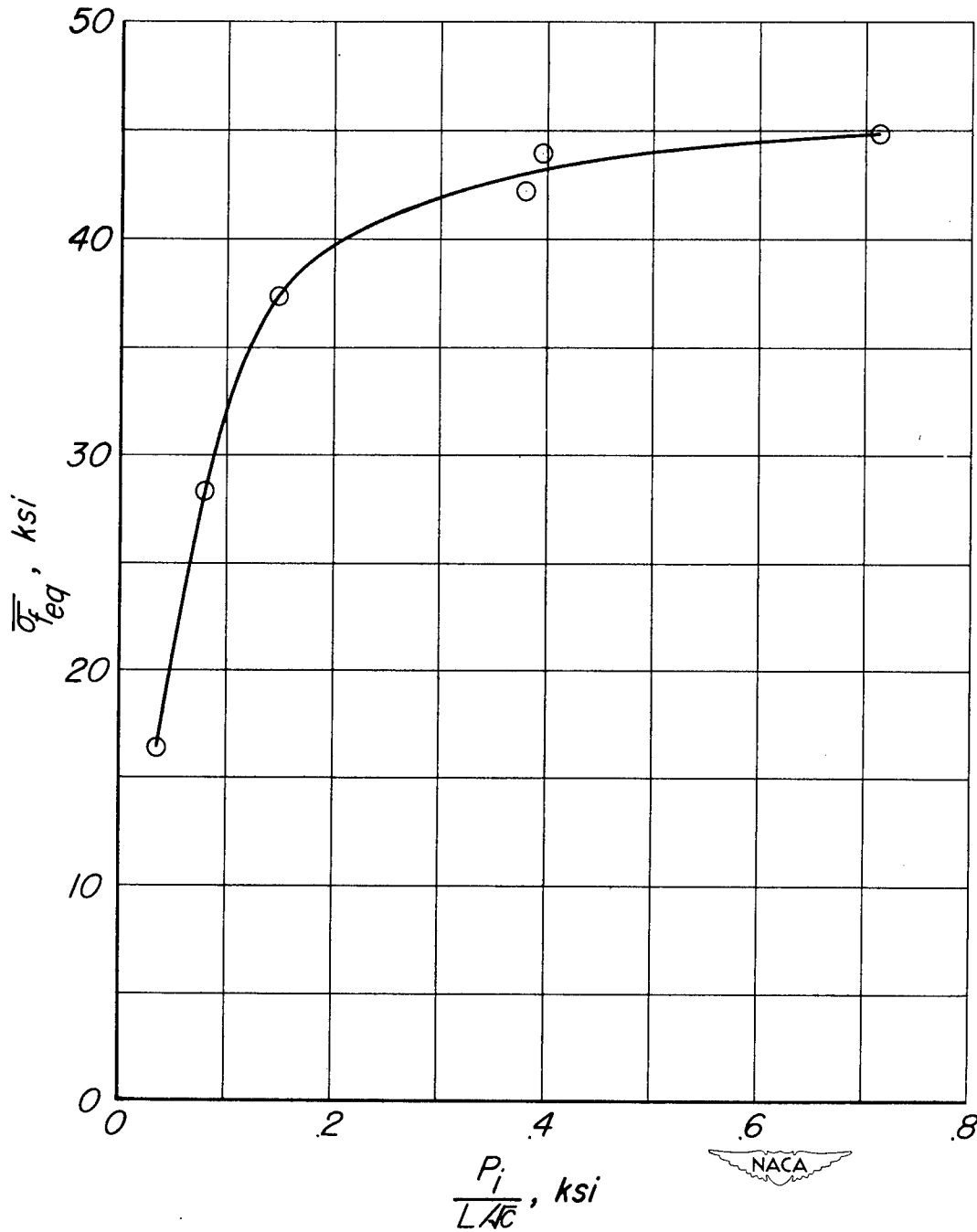

Figure 5.—Variation of stress with $\frac{P_i}{LAc}$ for extruded panels.

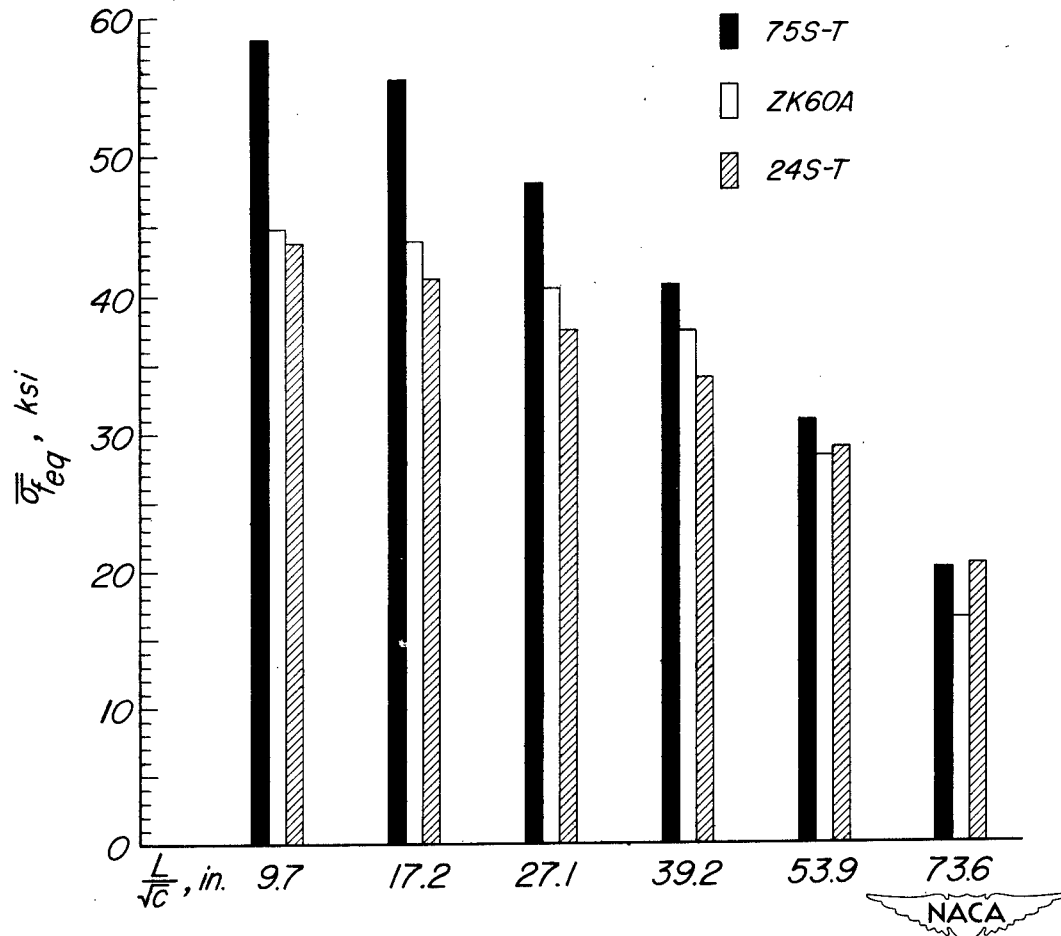

Figure 6.—Comparison of equivalent stresses carried by ZK60A extruded panels and the corresponding minimum weight designs of 24S-T and 75S-T Y-stiffened panels.

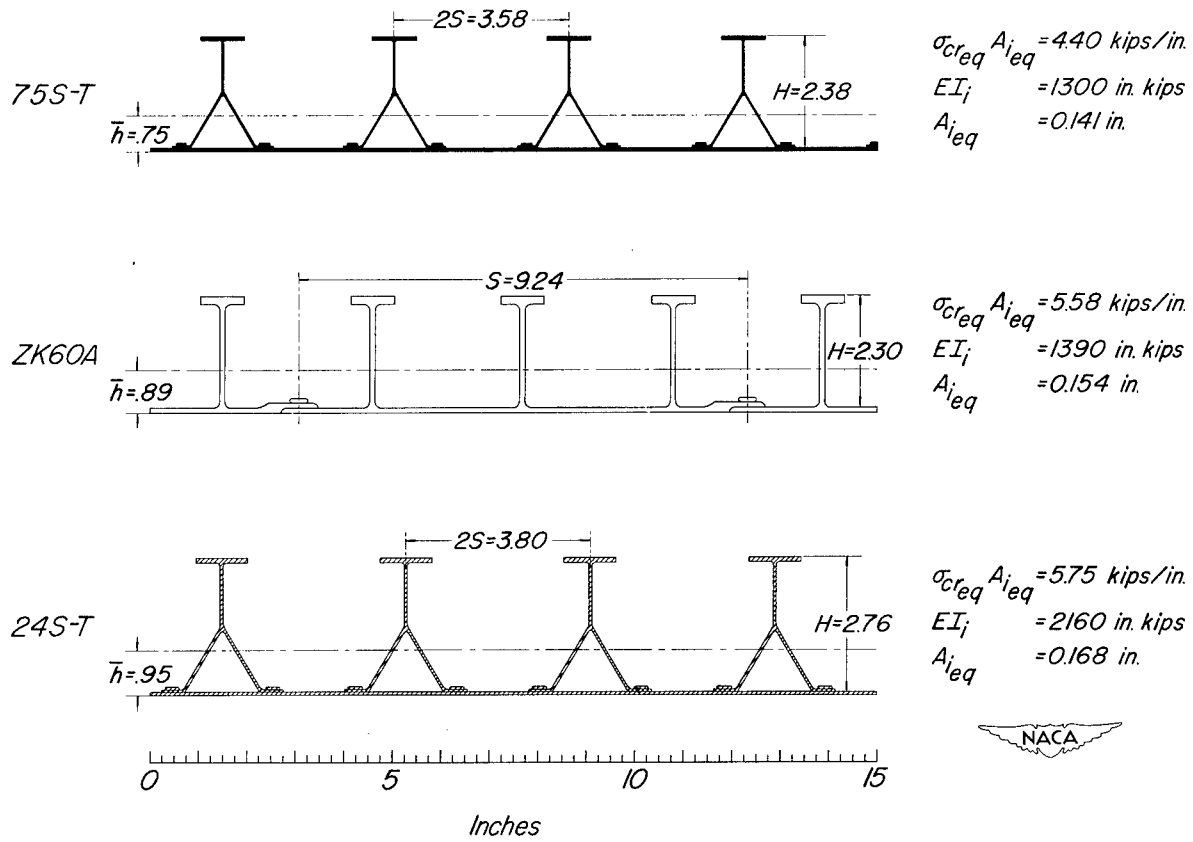

Figure 7.- Comparison of characteristics of the ZK60A extruded panel and 24S-T and 75S-T Y-stiffened panel designs for $P_j = 5.75$ kips per inch, $t_{seq} = 0.064$ inch, and $\frac{L}{\sqrt{c}} = 39.2$ inches.

