

# Summary of IMPACT Toolbox Models

Y. Chen and S. Fish

*Institute for Advanced Technology  
The University of Texas at Austin*

January 2000

IAT.R 0217

Approved for public release; distribution unlimited.

20000811 049

The views, opinions, and/or findings contained in this report are those of the author(s) and should not be construed as an official Department of the Army position, policy, or decision, unless so designated by other documentation.

# REPORT DOCUMENTATION PAGE

Form Approved  
OMB NO. 0704-0188

Public reporting burden for this collection of information is estimated to average 1 hour per response, including the time for reviewing instructions, searching existing data sources, gathering and maintaining the data needed, and completing and reviewing the collection of information. Send comments regarding this burden estimate or any other aspect of this collection of information, including suggestions for reducing this burden, to Washington Headquarters Services, Directorate for Information Operations and Reports, 1215 Jefferson Davis Highway, Suite 1204, Arlington, VA 22202-4302, and to the Office of Management and Budget, Paperwork Reduction Project (0704-0188), Washington, DC 20503.

1. AGENCY USE ONLY (Leave blank)		2. REPORT DATE January 2000		3. REPORT TYPE AND DATES COVERED technical report	
4. TITLE AND SUBTITLE Summary of IMPACT Toolbox Models				5. FUNDING NUMBERS Contract # DAAA21-93-C-0101	
6. AUTHOR(S) Y. Chen and S. Fish					
7. PERFORMING ORGANIZATION NAME(S) AND ADDRESS(ES) Institute for Advanced Technology The University of Texas at Austin 4030-2 W. Braker Lane, #200 Austin, TX 78759				8. PERFORMING ORGANIZATION REPORT NUMBER IAT.R 0217	
9. SPONSORING / MONITORING AGENCY NAME(S) AND ADDRESS(ES) U.S. Army Research Laboratory ATTN: AMSRL-WM-B Aberdeen Proving Ground, MD 21005-5066				10. SPONSORING / MONITORING AGENCY REPORT NUMBER	
11. SUPPLEMENTARY NOTES The view, opinions and/or findings contained in this report are those of the author(s) and should not be considered as an official Department of the Army position, policy, or decision, unless so designated by other documentation.					
12a. DISTRIBUTION / AVAILABILITY STATEMENT Approved for public release; distribution unlimited.				12b. DISTRIBUTION CODE A	
13. ABSTRACT (Maximum 200 words) This report documents the status of the Integrated Military Performance Analysis Collaborative Toolbox (IMPACT) as of its use in January 2000. IMPACT has become a rather large set of tools and has been ported for use in the latest version of MATLAB/Simulink. The goal with IMPACT was to provide a standard set of modeling blocks for vehicle-level performance analysis. To allow for suitable flexibility in order to adapt to various military applications, blocks depend on input characteristics for the componenets from the user, and a description of the mission to be simulated. The user is also responsible for the overall control system, as there has not yet been a general consensus on "best" control methods. A sample control system developed at the Institute for Advanced Technology is included in the IMPACT Demonstration Model. IMPACT is not stand-alone Plug and Play software. IMPACT is designed for users who are knowledgeable of both MATLAB/Simulink and the vehicle being simulated. This level of expertise allows the user more closely customize the simulation and understand the often complex simulation outputs.					
14. SUBJECT TERMS Itegrated Military Performance Analysis Collaborative Toollbox (IMPACT) MATLAB with Simulink; engine torque; Specific Fuel Consumption (SFC); 3-phase induction machine; d-q reference frame; 3-phase magnetic synchronous machine; flux; batteries (generic and pulse); vehicle dynamic blocks; pulsed power				15. NUMBER OF PAGES 25	
				16. PRICE CODE	
17. SECURITY CLASSIFICATION OF REPORT Unclassified	18. SECURITY CLASSIFICATION OF THIS PAGE Unclassified	19. SECURITY CLASSIFICATION OF ABSTRACT Unclassified	20. LIMITATION OF ABSTRACT UL		

## Table of Contents

1.	Abstract.....	1
2.	Overview of IMPACT.....	1
3.	Engines.....	2
	A) Scalable Engine with Speed Output.....	3
	B) Scalable Engine with Speed Input.....	3
4.	Machines.....	4
	A) Steady-State Electrical Machines.....	4
	i) Three-Phase Permanent Magnet Synchronous Machine (dq).....	4
	ii) Three-Phase Induction Machine(dq).....	5
	iii) Scalable Three-Phase Permanent Magnet Synchronous Machine.....	5
	B) Steady-State Electrical Controllers.....	5
	i) Stator Flux Orientation Torque Vector Controller.....	5
	ii) Stator Flux Orientation Torque Vector Controller with Flux Weakening.....	5
	iii) Stator Flux Orientation DC Current Controller.....	6
	iv) Stator Flux Orientation DC Current Controller with Flux Weakening.....	7
	v) Rotor Flux Orientation Torque Vector Controller.....	7
	vi) Global Maximum Torque Per Ampere Torque Controller.....	7
	vii) Rotor Flux Orientation DC Current Controller.....	7
	viii) Global Maximum Torque Per Ampere DC Current Controller.....	7
	C) Dynamic Electrical Machines.....	8
	D) Dynamic Electrical Controllers.....	8

	E) Miscellaneous.....	9
	i) Three-Phase Voltage Source.....	9
	ii) Reference Frame Transformation: abc to qd0.....	9
	iii) Inverse Reference Frame Transformation: qd0 to abc.....	9
5.	Batteries.....	9
	A) Generic Battery.....	10
	B) Generic Battery with Temperature Dependent Resistance.....	11
	C) Pulse Battery.....	11
	D) Pulse Battery with Charge Resistor.....	11
	E) Pulse Battery with Current Limits.....	11
6.	Vehicles.....	12
	A) Vehicle Dynamics (2 DOF).....	12
	B) Turning Tracked Vehicle Dynamics.....	13
	C) Amphibious Vehicle Dynamics.....	13
7.	Thermal.....	13
	A) Heat Exchangers.....	14
	B) Solid to Liquid Heat Exchanger.....	14
	C) Liquid to Gas Heat Exchanger: Radiator.....	15
	D) Insulated Sump.....	15
8.	Load and Couplings.....	15
	A) Speed Reducer.....	16
	B) Torque Converter.....	16
	C) Automatic Transmission.....	16
	D) Mechanical Loads.....	17
	i) Roller Bearing.....	17
	ii) Active Magnetic Bearing.....	17
	iii) Active Suspension.....	17
	iv) Windage.....	17
	v) Flywheel.....	17
	vi) Flywheel with Reset Speed.....	17
	vii) Flywheel with Magnetic Bearings.....	18

	viii) Flywheel with Magnetic Bearings and Reset Speed.....	18
	E) Electrical Couplings.....	18
	i) DC to DC Converter.....	18
	ii) AC to AC Converter.....	18
	iii) Three-Phase Diode Rectifier.....	19
	iv) Controlled Converter.....	19
	v) Three-Phase, Line-Commutated Inverter.....	19
	vi) Three-Phase, Pulse-Width Modulated, Voltage-Source Inverter.....	19
	F <sup>i</sup> ) Electrical Loads.....	19
	i) Three-Phase AC Dump Resistor.....	20
	ii) Filter Capacitor.....	20
9.	Pulsed Power.....	20
	A) Pulsed Alternator.....	21
	B) Pulse Forming Network.....	21
	C) High Powered Microwave.....	22
	D) Electromagnetic Armor with DC Bus-Based Charger.....	22
	E) Electromagnetic Armor.....	22
10.	Missions.....	22
	A) Mobility.....	23
	B) Pulsed Weapon.....	23
	C) Terrain.....	24
11.	Acknowledgment.....	24
12.	References.....	24
13.	Distribution List.....	25

## List of Figures

Figure 1.	IMPACT Version 3.00.....	2
Figure 2.	Engine Model Library.....	3
Figure 3.	Machine Model Library.....	4
Figure 4.	Steady-State Electrical Machine Model Library.....	4
Figure 5.	Steady-State Electrical Controller Model Library.....	6
Figure 6.	Dynamic Electrical Machine Model Library.....	8
Figure 7.	Dynamic Electrical Controller Model Library.....	8
Figure 8.	Miscellaneous Machine Model Library.....	9
Figure 9.	Battery Model Library.....	10
Figure 10.	Generic Battery Circuit Diagram.....	10
Figure 11.	Pulse Battery Circuit Diagram.....	11
Figure 12.	Circuit Diagram of Pulse Battery with Charge Resistor.....	12
Figure 13.	Vehicle Model Library.....	12
Figure 14.	Thermal Model Library.....	14
Figure 15.	Heat Exchanger Model Library.....	14
Figure 16.	Loads and Couplings Model Library.....	16
Figure 17.	Mechanical Couplings Model Library.....	16
Figure 18.	Mechanical Load Model Library.....	17
Figure 19.	Electrical Coupling Model Library.....	18
Figure 20.	Electrical Load Model Library.....	20
Figure 21.	Pulsed Power Model Library.....	21
Figure 22.	Mission Library.....	23

## Summary of IMPACT Toolbox Models Version 3.00

Yvonne Chen and Scott Fish

**Abstract**—This report documents the status of the Integrated Military Performance Analysis Collaborative Toolbox (IMPACT) as of its use in January 2000. IMPACT has become a rather large set of tools and has been ported recently for use in the latest version of MATLAB/Simulink. The goal with IMPACT was to provide a standard set of modeling blocks for vehicle-level performance analysis with suitable flexibility to allow it to adapt to various military applications. In doing so, the blocks depend on input characteristics for the components from the user, and a description of the mission to be simulated. The overall control system is also left to the user, as there has not yet been a general consensus on “best” control methods. A sample control system developed at the Institute for Advanced Technology is included in the IMPACT Demonstration Model. IMPACT is not stand-alone Plug and Play software. It functions as an add-on library of subsystem modeling blocks for MATLAB/Simulink. IMPACT was designed for users who are knowledgeable of both MATLAB/Simulink and the vehicle being simulated. This level of expertise allows the user to more closely customize the simulation and understand the often complex simulation outputs.

### 1 Overview of IMPACT

This document gives a general overview of the IMPACT code written and maintained by the Institute for Advanced Technology at The University of Texas (UT-IAT) Technology Integration group. IMPACT (Integrated Military Performance Analysis Collaborative Toolbox), Figure 1, was initially conceived as a standard set of modules for use in evaluating the performance of concept Hybrid Electric Combat Vehicle (HECV) configurations in simulated combat conditions. The modeling and simulation language for IMPACT is MATLAB with Simulink [1], a commercial package based on graphical or hard coded model assembly technique.

The toolbox is comprised of subsystem blocks, each of which contains the code that describes the behavior of a component or subsystem. The blocks are grouped into component libraries as shown in Figure 1. For IMPACT Version 3.00 [2], the component blocks are grouped into eight component libraries: Engines, Machines, Batteries, Vehicles, Thermal, Loads and Couplings, Pulsed Power, and Missions. By double clicking on a library folder, a new window is opened to illustrate the blocks or additional sub-libraries associated with that category of equipment.

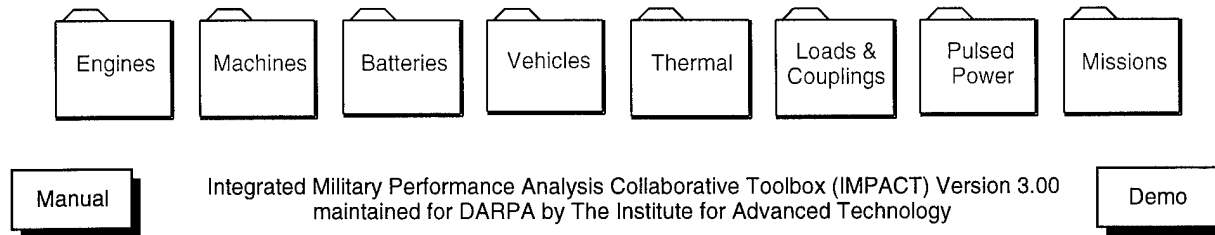

**Figure 1. IMPACT Version 3.00.**

The blocks are used by dragging and dropping their icons into the user's model window (see Simulink manual for creation of a Simulink graphical window). The overall model is then constructed by connecting the input and output ports associated with the various blocks to create the flow of vectored data between coupled components. Care must be taken when connecting these ports to insure that the correct information is passed. In addition, the user must define values and obey unit designations for parameters that are needed in most blocks. These parameters are shown in the block masks. The mask dialog box of each block contains structured variable names by default. It is suggested to use a top-level structured variable for each component from the toolbox in order to have a cleaner workspace. If two or more blocks from the toolbox are combined to make a new block, each block's top-level variable should then become fields of the single top-level variable.

The following sections present general description of the contents of the component libraries.

## **2 Engines**

The Engine Model Library, Figure 2, is composed of two models that can be used as user-defined engine blocks. An engine block is typically connected to mechanical transmissions or to a generator using a coupling (see the Loads and Couplings Library). Both engine models incorporate two components of engine drag torque: a constant Coulombic drag torque and a speed-dependent drag torque. Engine drag torque is active when the engine shaft is turning. To safeguard the model from unrealistic scenarios, shaft speeds less than epsilon, defined as  $2.2204 \times 10^{-16}$ , are considered zero rpm. The engine models, being quasi-steady, feed throttle flow, as a throttle lag response, and shaft speed to a steady-state performance table that yields developed torque. The performance tables can be scaled for notional engines from existing data using new values of rated power and rated speed. The mass of fuel consumed is subtracted from the initial mass of fuel. Outputs are Specific Fuel Consumption (SFC) and mass of fuel remaining. When the mass of fuel remaining is less than epsilon, the engine is shut off.

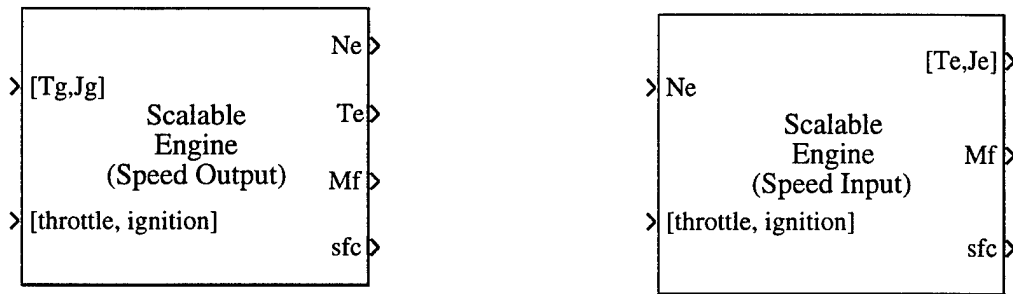

Figure 2. Engine Model Library.

### Scalable Engine with Speed Output

The Scalable Engine Model with Speed Output will accurately represent engine torque and fuel consumption characteristics given its input throttle setting and shaft torque. The model is quasi-steady with a user-defined first-order lag in response to the throttle. The time constant for this lag is a mask input which accounts for the transient associated with achieving air/fuel mixture equilibrium. Limits are used in the throttle lag implementation to assure combustion rates between 0 and 1 (full steady-state rating). The developed torque is interpolated from a lookup table of steady-state torque performance as a function of shaft speed and throttle setting. SFC is also empirical data. The SFC table is scaled with the engine power and speed. The output fuel mass represents the remaining mass of fuel in tanks connected to this engine. This data can be used by vehicle dynamics models (described later) to account for a decrease in vehicle weight due to fuel mass expenditure during engine operation. An on/off signal should be multiplexed with the input throttle signal to control ignition of the engine. Off stops fuel consumption and torque developed from combustion.

### Scalable Engine with Speed Input

The Scalable Engine Model with Speed Input will accurately represent engine torque and fuel consumption characteristics given its input throttle setting and shaft speed. The model is quasi-steady with a user-defined first-order lag in response to the throttle. The time constant for this lag is a mask input which accounts for the transient that achieves air/fuel mixture equilibrium. Limits are used in the throttle lag implementation to assure combustion rates between 0 and 1 (full steady-state rating). The developed torque is picked from a lookup table with steady-state performance data. SFC is also empirical data. The SFC table is scaled with the engine power and speed and is assumed independent of engine power rating. The output fuel mass represents the remaining mass of fuel in tanks connected to this engine. This data accounts for weight loss in time by vehicle dynamics models. An on/off port is used to control ignition of the engine. Off stops fuel consumption and torque developed from combustion.

### 3 Machines

The Machine Model Library, Figure 3, contains model blocks for a variety of electrical machines and their controllers for conversion between electrical and mechanical energy and are classified by Permanent Magnet, Induction, Synchronous, and Reluctance groups. All except one (Scalable Three-Phase Permanent Magnet Synchronous Machine) of the machine models require power electronics and control, which govern their behavior. Several types of power electronics converters may be suitable to be coupled with a single machine.

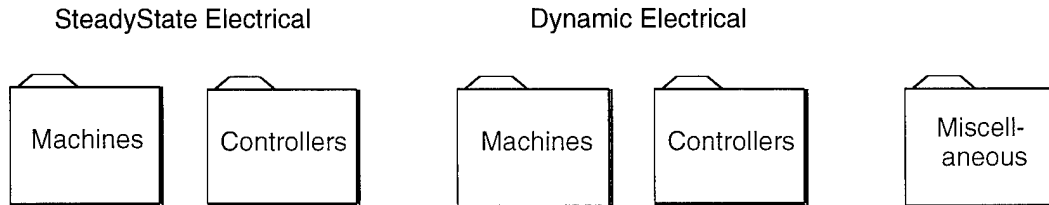

Figure 3. Machine Model Library.

#### Steady-State Electrical Machines

These machines (see Figure 4) neglect the high frequency electrical transient terms in the description of the machine performance. By doing so, these models can be run at much larger time steps than that required for the dynamic electrical models described later. Two of the models are written in direct and quadrature reference frame to again eliminate terms which depend directly on rotor position and therefore require greater integration time resolution. The third model, which is based on the machine speed-torque efficiency map, can serve as a user-defined machine block.

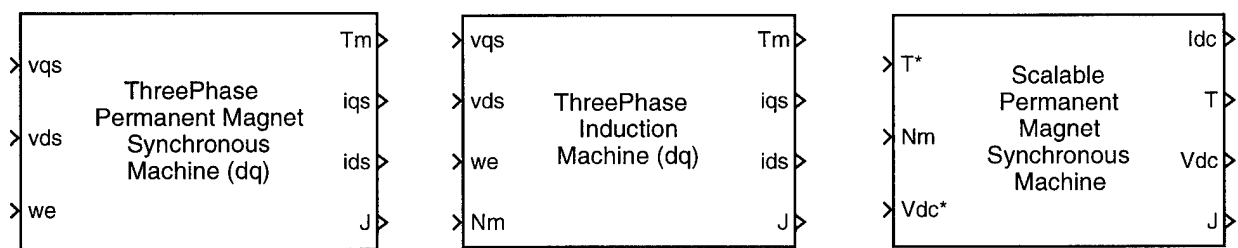

Figure 4. Steady-State Electrical Machine Model Library.

**Three-Phase Permanent Magnet Synchronous Machine (dq).** This model is used to represent a three-phase permanent magnet synchronous machine. The model is derived from the equivalent circuit for the direct and quadrature axes, obtained from Park's Transformation [3], in the synchronously rotating d-q reference frame.

**Three-Phase Induction Machine (dq).** This model is used to represent a three-phase induction machine. The model is derived from the equivalent circuit for the direct and quadrature axes, obtained from Park's Transformation, in the synchronously rotating d-q reference frame.

**Scalable Three-Phase Permanent Magnet Synchronous Machine.** This model is used to represent a three-phase permanent magnet synchronous machine. The model uses system efficiency maps for calculating the various steady-state system inputs and outputs, which include bus voltage, winding current, and torque. The system efficiency maps are normalized so that the model is scalable through torque and speed parameters.

### **Steady-State Electrical Controllers**

The machine controllers (see Figure 5) in this section are all feed-forward torque controllers. They do not include feedback terms because there are no electrical dynamics to control in achieving a desired torque for a given shaft speed. Given the shaft speed and desired torque, the appropriate stator voltage magnitude and frequency can be directly calculated from the machine equations. In the case of DC current control, the equivalent torque command can be calculated from the machine equations and a power conservation equation across the controlled converter.

**Stator Flux Orientation Torque Vector Controller (PM Machine).** This controller is designed to be used with the Steady-State, Three-Phase Permanent Magnet Machine (dq) and the Controlled Converter models. Stator flux orientation torque vector control for the permanent magnet machine is also widely known as "brushless DC" control. In this controller model, one component of stator current is held constant while the other component of stator current is varied to achieve the desired shaft torque. In a sense, the variable component of stator current is similar to the DC current across the armature in a DC machine in that each is directly proportional to the developed torque in the machine. In the synchronously rotating reference frame, the D-axis component of stator current is held constant (at zero for standard "brushless DC" control) and is termed the "flux-producing" component of stator current, while the Q-axis component is varied and is called the "torque-producing" component of stator current.

**Stator Flux Orientation Torque Vector Controller with Flux Weakening (PM Machine).** This controller is designed to be used with the Steady-State, Three-Phase Permanent Magnet Machine (dq) and the Controlled Converter models.

This control algorithm is identical to the previous one, except that flux weakening is included. The concept of flux weakening was introduced to overcome the problem of driving a permanent magnet machine in motor mode at high rotor speeds which in turn produces a high back EMF in the machine. The only way to get current to flow into the machine in motor mode is if the terminal voltage is higher than the back EMF, and by creating an opposing flux field such that the *net* effective flux field is reduced. A lower effective flux field translates into a lower back EMF for a given shaft speed, thus allowing the machine to operate at higher shaft speeds. In practice, standard vector control is used up to the speed at which the limit back EMF is reached. Above this speed, flux weakening is used to hold the back EMF at the limit while allowing the speed of the machine to increase.

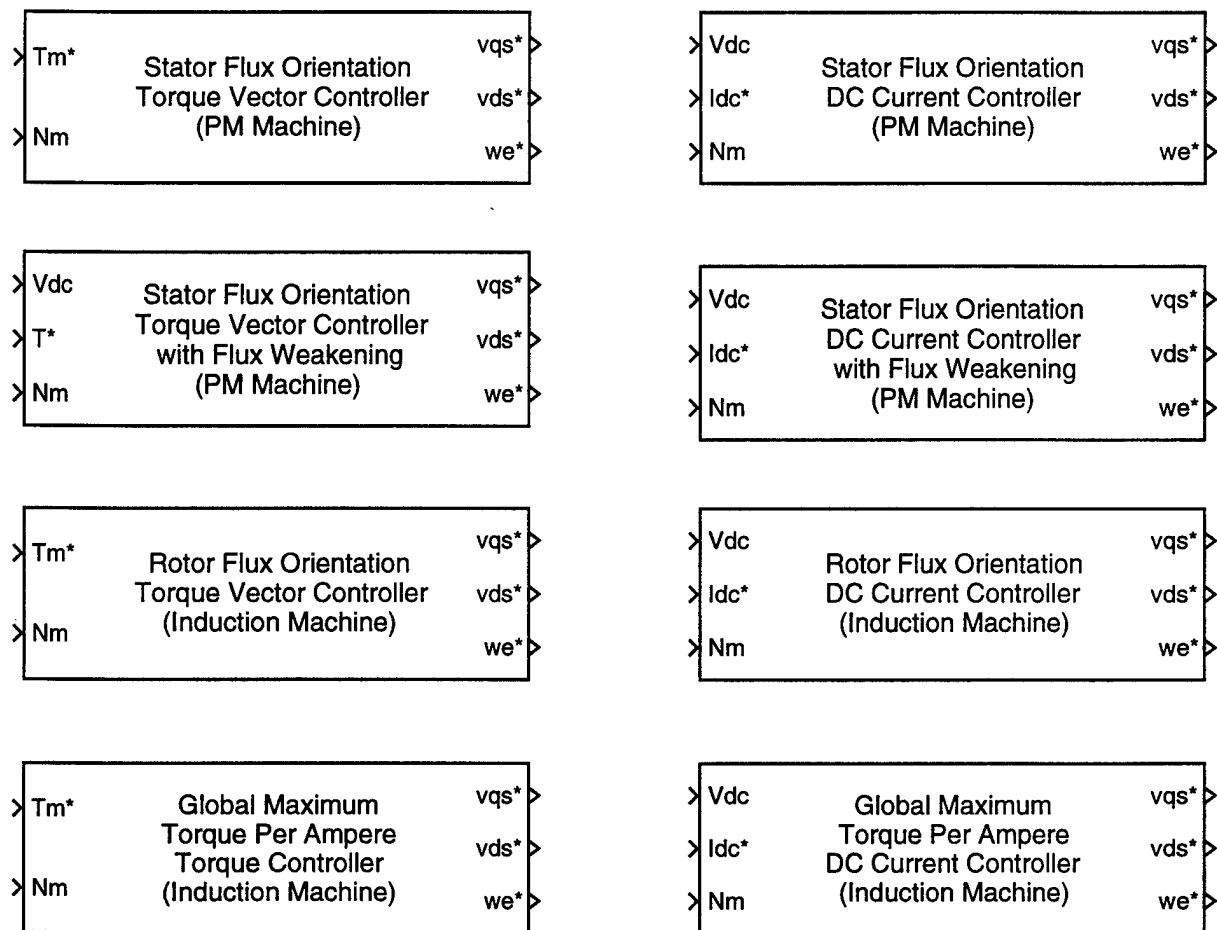

Figure 5. Steady-State Electrical Controller Model Library.

Obviously, it takes power to produce this opposing flux field, and none of this power is transformed into useful mechanical power. Thus, the efficiency of the machine can be expected to be reduced in the flux weakening region. Such is the tradeoff for being able to operate the machine in the high-speed region.

In this control scheme, in the region of standard control, the D-axis component of stator current is held constant at zero. In the flux weakening region, the D-axis current becomes negative to produce the opposing flux field. In either region, the Q-axis current is adjusted with respect to the D-axis current such that the desired shaft torque is produced.

**Stator Flux Orientation DC Current Controller (PM Machine).** This controller is designed to be used with the Steady-State, Three-Phase Permanent Magnet Machine (dq) and the Controlled Converter models.

The only difference between this control algorithm and the Stator Flux Orientation Torque Vector Controller is that the equivalent torque command is calculated from the DC current command and the Permanent Magnet Machine and Controlled Converter equations. Once the equivalent torque command is known, the identical control algorithm may be used.

**Stator Flux Orientation DC Current Controller with Flux Weakening (PM Machine).** This controller is designed to be used with the Steady-State, Three-Phase Permanent Magnet Machine (dq) and the Controlled Converter models.

The only difference between this control algorithm and the Stator Flux Orientation Torque Vector Controller with Flux Weakening is that the equivalent torque command is calculated from the DC current command and the Permanent Magnet Machine and Controlled Converter equations. Once the equivalent torque command is known, the identical control algorithm may be used.

**Rotor Flux Orientation Torque Vector Controller (Induction Machine).** This controller is designed to be used with the Steady-State, Three-Phase Induction Machine (dq) and the Controlled Converter models.

In the induction machine model the inputs to the machine (via its controlled converter) are  $v_{qs}$ ,  $v_{ds}$  and  $\omega_e$ . It is assumed that the machine controller has access to the measured shaft speed of the machine as well. Thus, the object of the machine controller is to specify  $v_{qs}^*$ ,  $v_{ds}^*$  and  $\omega_e^*$  based on  $\tau_m^*$  and  $\omega_r$  such that  $\tau_m = \tau_m^*$ . Vector control in the induction machine may be achieved by maintaining either the rotor, stator, or airgap flux at a constant level. The simplest and most practical implementation is constant rotor flux control, also known as vector current control.

**Global Maximum Torque Per Ampere Torque Controller (Induction Machine).** This controller is designed to be used with the Steady-State, Three-Phase Induction Machine (dq) and the Controlled Converter models.

The Global Maximum Torque Per Ampere (GMTA) controller is based on work done by Wasynczuk and Sudhoff [4]. As the name of the control algorithm suggests, the objective of this controller is to produce the desired torque with the minimum amount of stator current possible.

**Rotor Flux Orientation DC Current Controller (Induction Machine).** This controller is designed to be used with the Steady-State, Three-Phase Induction Machine (dq) and the Controlled Converter models.

Rotor flux orientation DC current control is essentially the same as rotor flux orientation torque vector control, with the only difference being that the controlled variable is DC current rather than net shaft torque. In order to leverage the development already done for the torque controller, we derived the equivalent torque command that will result in the desired DC current at the terminals of the controlled converter. We need not address torque losses here, as we are not concerned with the actual net torque at the shaft.

**Global Maximum Torque Per Ampere DC Current Controller (Induction Machine).** This controller is designed to be used with the Steady-State, Three-Phase Induction Machine (dq) and the Controlled Converter models.

Global maximum torque per ampere DC current control is essentially the same as global maximum torque per ampere torque control, with the only difference being that the controlled variable is DC current rather than net shaft torque. In order to leverage the development already done for the torque controller, we derived the equivalent torque command that will result in the

desired DC current at the terminals of the controlled converter. We need not address torque losses here, as we are not concerned with the actual net torque at the shaft.

### Dynamic Electrical Machines

This model (see Figure 6) simulates the dynamic response of an induction machine. Note the inputs and outputs of this model are in the fixed abc frame, while the calculation of the machine variables are carried out in the rotating (qd0) frame.

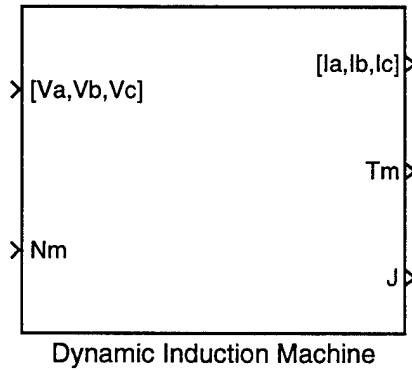

Figure 6. Dynamic Electrical Machine Model Library.

### Dynamic Electrical Controllers

This model (see Figure 7) calculates the dynamic bus current for a commanded torque at a certain bus voltage level.

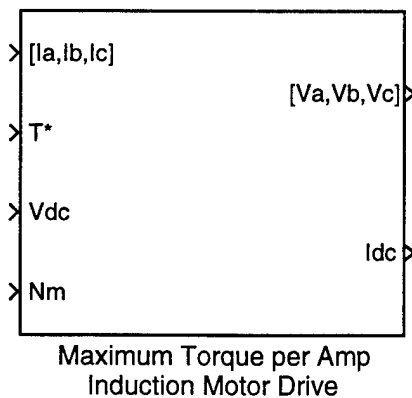

Figure 7. Dynamic Electrical Controller Model Library.

## Miscellaneous (See Figure 8)

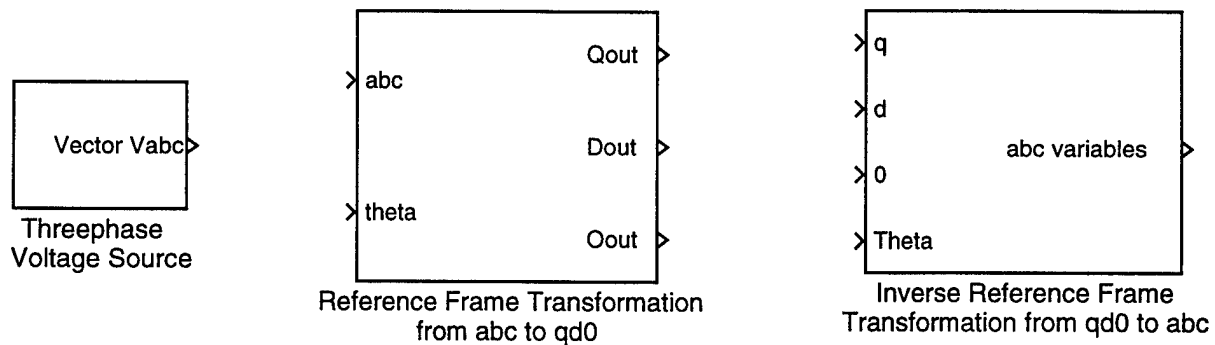

Figure 8. Miscellaneous Machine Model Library.

**Three-Phase Voltage Source.** This block represents a three-phase voltage source with user-defined voltage amplitude and frequency.

**Reference Frame Transformation: abc to qd0.** This block performs the transformation of stator variables from the fixed frame (abc) of the stator to the rotating frame (qd0) of the rotor (Park's transformation).

**Inverse Reference Frame Transformation: qd0 to abc.** This block performs the inverse Park's transformation.

## 4 Batteries

The battery models are shown in Figure 9. When modeling the battery system, each battery cell is assumed to have the same open circuit voltage and state of charge. In real systems, each battery can be at a somewhat different state of charge and therefore have a different open circuit voltage. Because this model scales the battery from the unit performance data input, typically at the cell or module level, it is incapable of accounting for these variations. It should be noted that the use of this model for each unit individually in a simulation could capture some of this behavior with an appropriate control of the current distribution to each.

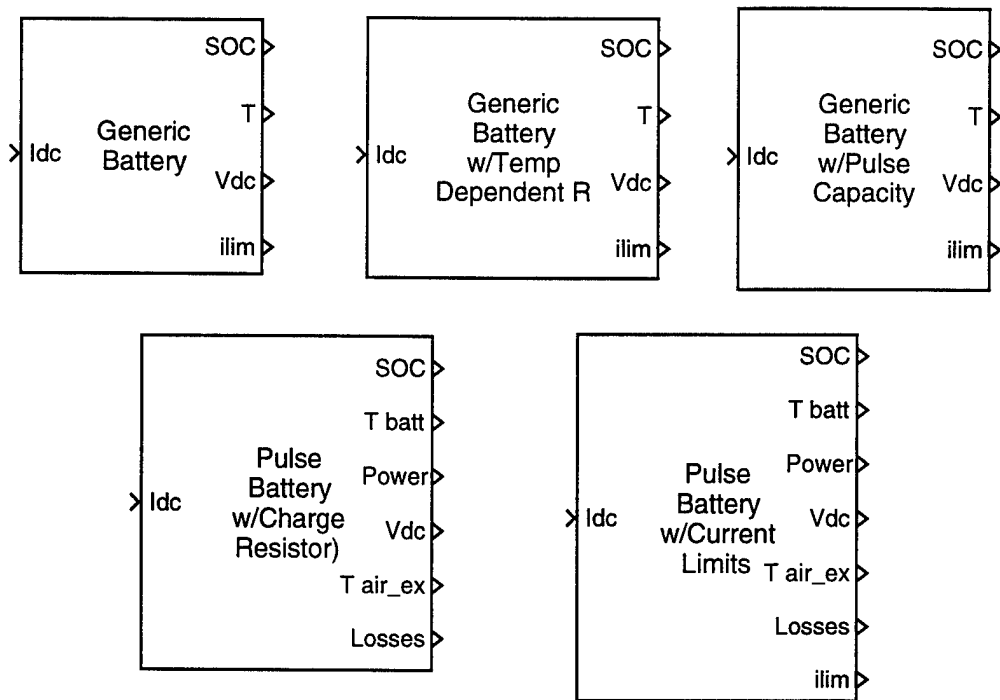

Figure 9. Battery Model Library.

### Generic Battery

The purpose of this block is to provide a voltage source to the system which has finite capacity and exhibits general behavioral characteristics of a battery. This model can be used to represent a single battery or a string, but the resulting string is assumed to share charging and discharging functions equally. No attempt is made to model the control of battery strings in this model. The generic battery circuit diagram is shown in Figure 10.

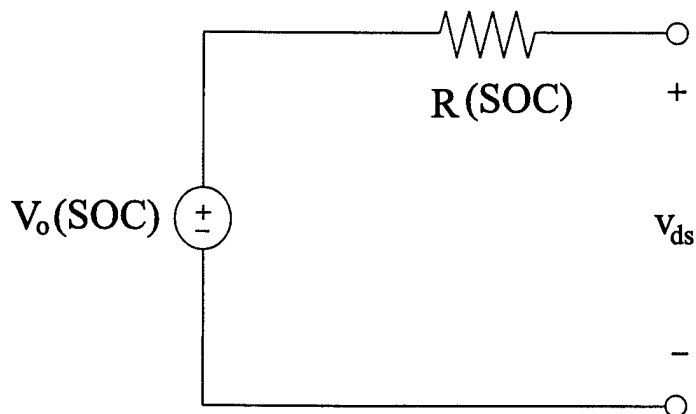

Figure 10. Generic Battery Circuit Diagram.

### Generic Battery with Temperature Dependent Resistance

The model is most accurate for battery applications where the current levels are on the order of 3C or less. Note that this model cannot capture the influence of low impedance capacity for pulse operation which has been observed in some battery types such as lithium ion. If sufficient pulse data is available to use the pulse model, it should be selected rather than this model. The equivalent circuit diagram of this model is the same as shown in Figure 10.

### Pulse Battery

The circuit includes a capacitor and additional resistor as shown in Figure 11. These additional elements allow the pulse behavior of the battery to be more accurately represented as would be expected from such a topology. Note that  $C$  is a constant parameter and  $R_e$  and  $R_t$  are functions of temperature (if you have data) and SOC. Because the  $R_c$  can be a weak function of SOC, we implement the  $R_e$ ,  $R_t$  lookup tables as a function of temperature and  $V_o$  resulting from SOC calculations.

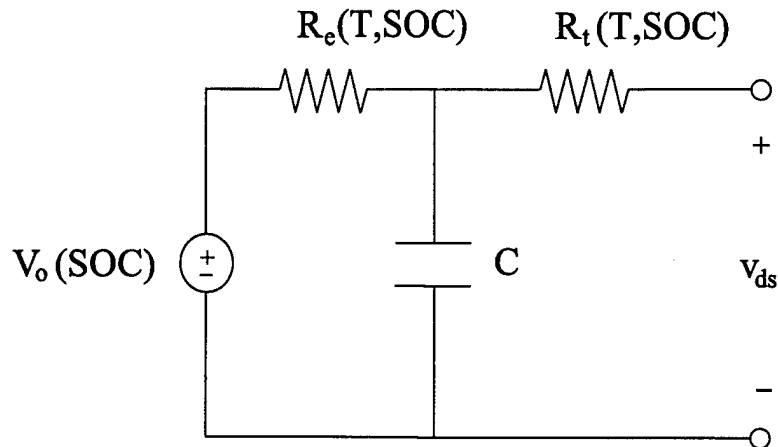

Figure 11. Pulse Battery Circuit Diagram.

### Pulse Battery with Charge Resistor

Pulse Battery with Charge Resistor is the same as the Pulse Battery except this circuit includes a resistor in series with the capacitor as shown in Figure 12. This addition allows the pulse behavior of the battery to be more accurately represented as would be expected from such a topology.

### Pulse Battery with Current Limits

Pulse Battery with Current Limits is the same as the Pulse Battery with Charge Resistor but this model includes the calculation of present state terminal current limits. The limits are maximum current the battery can source or sink under present SOC (state-of-charge). This model has the same circuit diagram shown in Figure 12.

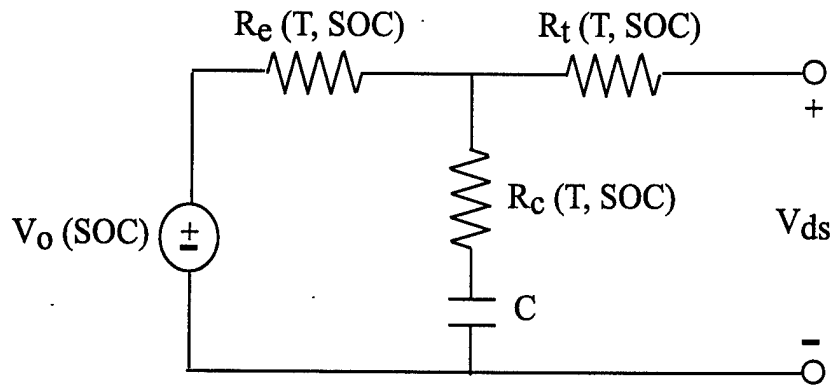

Figure 12. Circuit diagram of pulse battery with charge resistor.

## 5 Vehicles

This section describes the vehicle dynamics blocks, Figure 13, which have been developed so far. The general convention for these models is that they take all the loads impressed on the vehicle and determine what the corresponding vehicle acceleration, velocity, and position is at each time step. No control measures are taken in these blocks to achieve desired performance. This function should be performed separately in an appropriate model of the driver or automatic control system. All of the models at this time are point mass types, with no inclusion of pitch, roll or turning motions. Models which include these effects are currently in development.

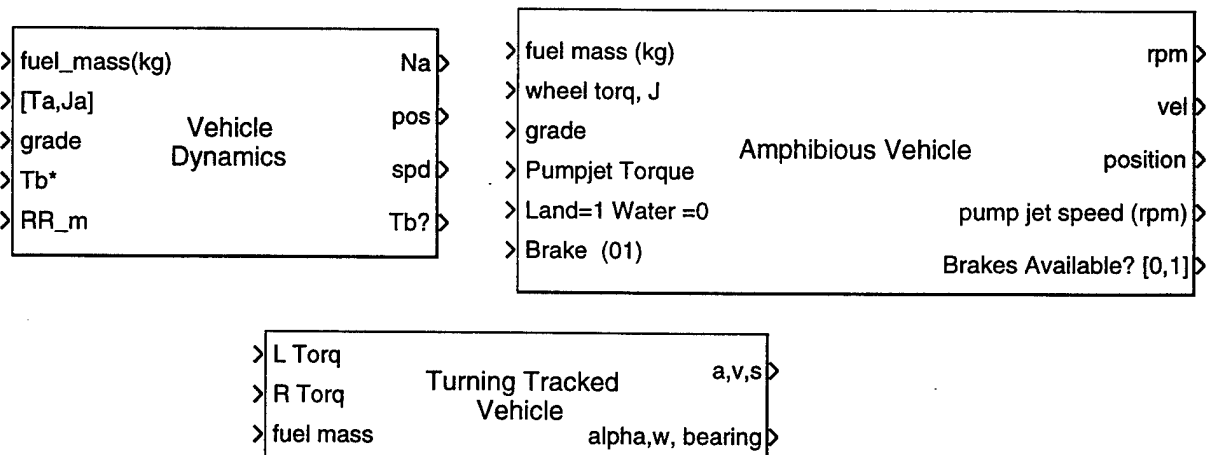

Figure 13. Vehicle Model Library.

### Vehicle Dynamics (2 DOF)

The purpose of this block is to simulate the two Degree Of Freedom (DOF) (horizontal and vertical translation) dynamics of a vehicle by summing forces from various inputs including aerodynamic drag, rolling resistance, and drag due to slope. This sum is divided by the inertia of the vehicle to determine its acceleration which is then integrated once for velocity and twice for

position. This model is appropriate for general modeling of vehicles and, in particular, vehicles with tracks where there is data on the static rolling resistance. This model does not include active suspension loads. The vehicle model takes, as an input, the total amount of torque available from all drive motors. The model also inputs a proportional brake command for active mechanical braking, and returns a braking availability signal for vehicle controllers. Both tracked and wheeled vehicle dynamics may be simulated by changing the rolling resistance and drag coefficient of the vehicle in the mask parameters.

### **Turning Tracked Vehicle Dynamics**

This Simulink block models the dynamics and kinematics of a turnable tracked vehicle. The model is designed to take motor torques for the left and right side drive sprockets and the amount of fuel remaining as inputs and output vectors of acceleration, velocity, and path length and angular acceleration, angular rotation rate, and total angle rotated. The user should take caution in interpreting the output. The model is capable of outputs which are not physically possible and represent a poor choice of torque input on the part of the user. Specifically, if the user drives the torque difference too high (89%) while moving forward at high speed (100%), the model will become unstable in rotation and the turning rate will grow without bound.

This model was initiated for a project which did not receive funding. It has yet to be used in a practical application and may require modification for certain vehicle concepts.

### **Amphibious Vehicle Dynamics**

This Simulink model was developed to simulate the mobility performance of an amphibious combat vehicle. Land propulsion is derived from the sprocket torque in the same manner as described above in Vehicle Dynamics (2DOF) section. Water-borne propulsion is provided by pumpjets. The land drive system contributes no propulsive force while the vehicle is in the water. The model was designed to take drive motor torque, pump motor torque, fuel mass remaining, terrain slope, terrain type (water or land), and a brake command as inputs and output vehicle velocity and position. The corresponding shaft speeds of the drive motors are also calculated to feed back to their respective motor models, as well as a brake availability signal for vehicle controllers. Pumpjet Thrust as a function of shaft torque must be known and input through the model mask.

This model was initiated for a project that did not receive funding. It has yet to be used in a practical application and may require modifications to suit specific vehicle concept.

## **6 Thermal**

This section includes components, see Figure 14, for modeling thermal effects. The few models included so far are simple but surprisingly powerful for use in vehicle applications. They include both the heat transfer characteristics and the fluid characteristics in a manner which allows them to be used as an overlay to existing electrical/mechanical models. The thermal library folders contain models for heat exchangers and sumps, with future additions being pumps and fans. Control blocks, user supplied in conjunction with those in the thermal library, will provide a basic thermal model of the vehicle. Note that the library models operate in metric units.

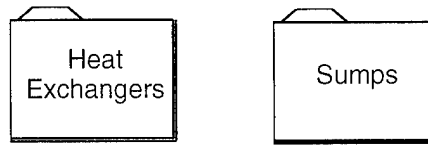

Figure 14. Thermal Model Library.

### Heat Exchangers

The Heat Exchanger Model Library (see Figure 15) contains two models for the conversion of heat energy from one medium to another. The first and most basic of these to model is the solid to liquid heat exchanger. It is used when heat generated in a solid is cooled with a forced fluid. This model can also be used to cool a sump with a forced fluid such as a cooling coil of forced fluid sitting in an oil bath. And second, the radiator (liquid to gas heat exchanger) model with a single coolant loop is used when heat generated in a forced fluid is cooled with forced air flow.

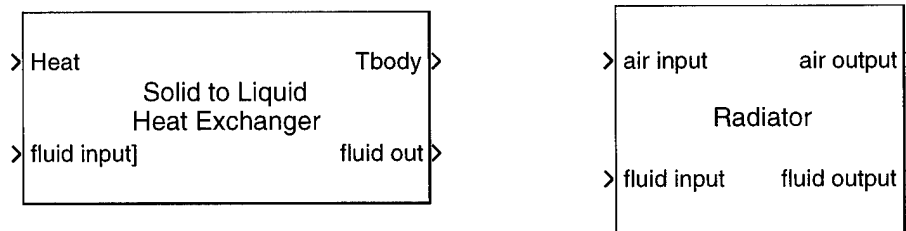

Figure 15. Heat Exchanger Model Library.

**Solid to Liquid Heat Exchanger.** The solid to liquid heat exchanger models the temperature dynamics of a homogeneous thermal mass with active liquid cooling. The model balances heat transfer against the temperature change in the coolant by relating the convective heat transfer of the solid to the specific heat and flow rate of the coolant. The specific heat of the solid and coolant are assumed not to vary over the temperature range being simulated. The pressure drop in the coolant line is also modeled. The model is calibrated with a known operating condition and a temperature-dependent coolant viscosity. Used as one segment of a coolant loop, the model allows the coolant dynamics and its heat removal from the solid to be coupled with the heat transfer in other parts of the loop and the pumping power being used.

This model assumes the coolant flow is well mixed (turbulent). Energy is balanced between heating the solid and convection to the coolant. Heat flow to the coolant is naturally dependent on the temperature of the solid and the average temperature of the coolant. Heat conduction in the mass being cooled is assumed to be much faster than the heat transfer rate in the heat exchanger which allows us to assume that the temperature of the solid is representative of a wall temperature in contact with the coolant.

The solid is modeled as a single lumped thermal mass, and therefore does not allow for "hot spots." This method is adequate when the coolant is designed to be close to the heat source,

and the thermal conductivity is high compared with the convection at the coolant/wall interface. Greater resolution of the temperature distribution in a solid which has significant internal thermal resistance will require a more complex model and associated geometric calibration.

**Liquid to Gas Heat Exchanger: Radiator.** The radiator model provides a method of representing the heat transfer associated with typical cross-flow type radiator hardware. The radiator model can be used more than once to account for stacked arrangements by properly feeding the output (typically air) temperature, pressure and mass flow rate into the input of the downstream radiator model.

Like the solid to liquid heat exchanger model, the equations used to determine output temperatures assume that the flow rates in both the air and the coolant are not zero. This limitation is based on the calculation of the net temperature increases which contain the flow rate in the denominator of their expressions. The specific heat of both the air and water are assumed to be constant over the temperature range being simulated. The temperature for the air and coolant for purposes of balancing the heat flow are assumed to be the average of the inlet and outlet temperatures.

The model simply balances the thermal energy lost by the coolant with the thermal energy gained by the gas (air). The heat transfer rate between the two media is controlled by the convective heat transfer coefficient between the radiator and the air, and the associated surface area of the radiator exposed to the air. A value for the combination of these two parameters ( $h \cdot A$ ) can be determined from testing.

### **Insulated Sump**

The insulated sump block models a control volume of fluid that may have a steady rate of change in volume determined by user-defined mass flow rates. Along with these inputs, the model uses the incoming temperature of the fluid as an input and the initial temperature of the sump to determine the outlet temperature of the fluid. The sump temperature is set equal to the outlet temperature and the simulation runs another time step, repeating until the time steps are completed. This calculation is made with a weighted average, so that the units of temperature need not correspond to the SI units required throughout the model. Sump temperature is calculated via an energy balance of both cooling loops. An absolute temperature scale must be selected. Though it is not necessary for present calculations, it will be utilized in the next generation of sump models.

The steady-state model assumes perfect mixing of fluid in the sump and the flow to be well mixed (turbulent). The surface area of the fluid in the sump is assumed to be constant (i.e., the walls of the sump are vertical) and zero when empty.

## **7 Loads and Couplings**

The Loads and Couplings Library contains both mechanical and electrical loads and couplings as seen in Figure 16. These blocks can be used to model a wide variety of bearings, active suspension, flywheels, electrical resistors and inverters.

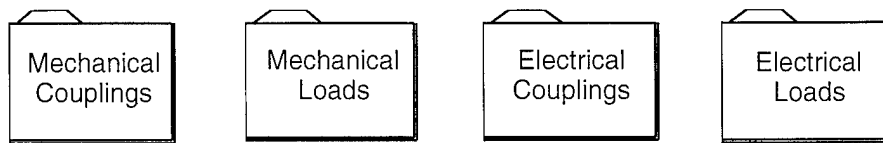

Figure 16. Loads and Couplings Model Library.

### Mechanical Couplings (See Figure 17)

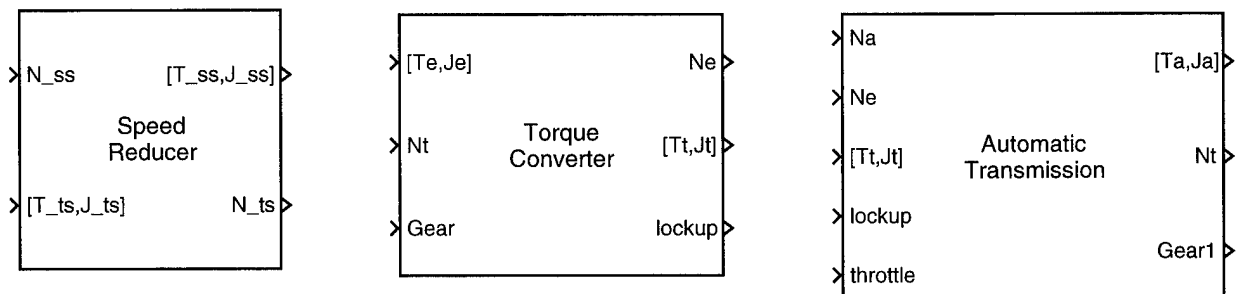

Figure 17. Mechanical Couplings Model Library.

**Speed Reducer.** This model allows connection of two shafts with a gear ratio. A gear ratio of 1 can model a rigid connection. The model assumes no compliance in the coupling (the natural frequency of the components is high compared with the inverse of the simulation time step). The model assumes normal causality in the shafts: one shaft is a torque source and the other is a speed source.

Bearing and other losses are accounted for by a constant efficiency parameter which will reduce the power flow through the coupling in the direction of positive power flow.

**Torque Converter.** This block models a hydrodynamic torque converter, which consists of a pump and a turbine. The torque converter provides torque multiplication between the engine and the transmission. Unlike the speed reducer, the torque converter model does not incorporate an explicit efficiency and compliance.

The lookup tables associated with the speed ratio and the torque ratio take into account a variable efficiency.

**Automatic Transmission.** This block models an automatic transmission. Shifting is determined based on engine speed and throttle setting.

## Mechanical Loads (See Figure 18)

**Roller Bearing.** This block models a roller bearing. Drag torque is calculated based on thrust load, radial load, and viscous drag.

**Active Magnetic Bearing.** This block approximately models an active magnetic bearing. Bearings are assumed to have a defined relationship between air gap flux and force. This model linearly interpolates the electric losses and rotating losses for the given input force at the base speed. The rotating losses are assumed to be due to eddy current and hysteresis losses in the magnetic core of the rotor. The eddy current losses will be proportional to speed squared while the hysteresis losses will be proportional to the speed. This allows scaling for speed variations of these rotating torques to account for speed effects.

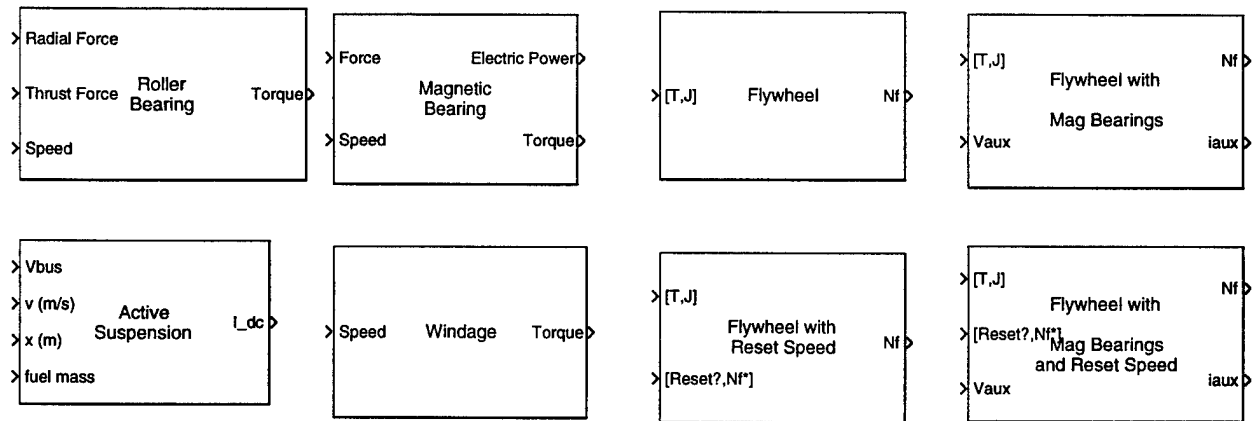

Figure 18. Mechanical Load Model Library.

**Active Suspension.** This block models the approximate power load of an active electromagnetic suspension system. The data used are based on output from suspension simulations by the Center for Electromechanics at The University of Texas (UT-CEM).

**Windage.** Calculates windage as a function of speed for a constant vacuum pressure in a rotating machine.

**Flywheel.** This block models a mechanical flywheel with internal viscous drag torque.

**Flywheel with Reset Speed.** This model is similar to the standard flywheel model but allows the speed to be reset to represent step changes in energy loss in the period of a time step. This feature allows the flywheel model to mimic the behavior of pulsed alternators.

The model assumes that the energy extraction under pulsed conditions occurs much faster than the time step of the simulation. The model relies on a trigger signal to tell it when a change in energy is required. Along with this trigger signal is the magnitude of energy being extracted or added, which is used to calculate the required change in speed. This change in speed is added to the previous speed of the flywheel, and the initial condition for the speed integration is reset.

**Flywheel with Magnetic Bearings.** This model is similar to the standard flywheel model but includes the model for the magnetic bearings (also in this section). The model is a simple extension of the flywheel and magnetic bearing models.

**Flywheel with Magnetic Bearings and Reset Speed.** This is an integration of the flywheel with reset speed and the magnetic bearing models.

**Electrical Couplings (See Figure 19)**

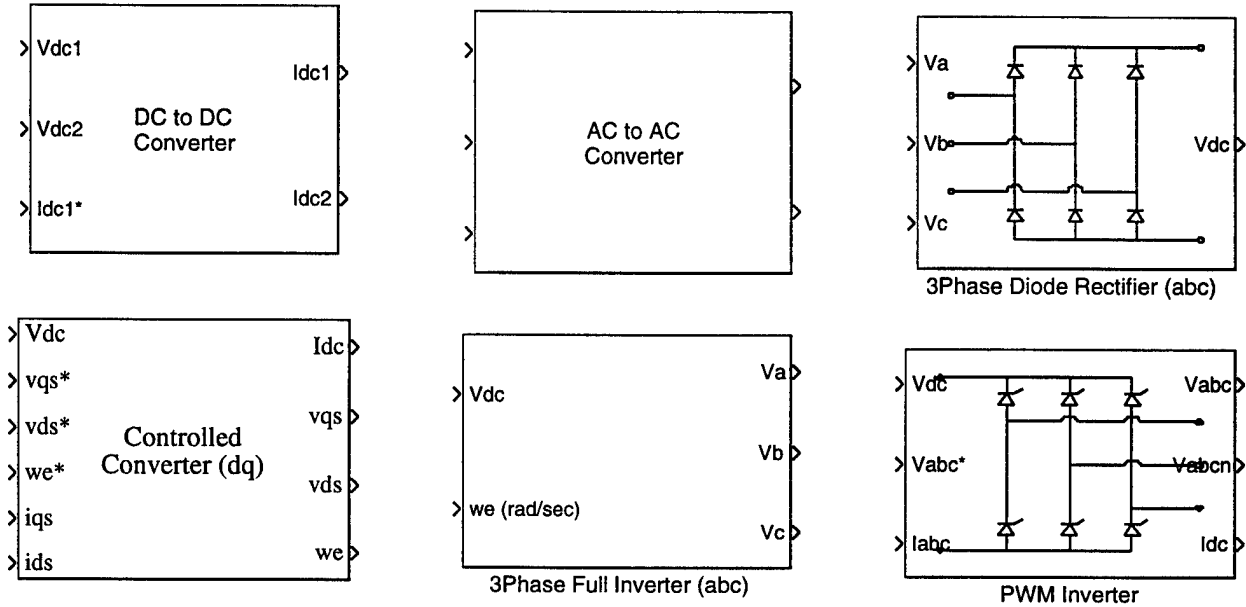

**Figure 19. Electrical Coupling Model Library.**

**DC to DC Converter.** The DC-DC Converter block models a solid-state converter which inverts, transforms, and rectifies electricity between two DC buses. This model is a simple power transformer with efficiency which accounts for the direction of power flow.

The frequency of the inverted power is assumed to be high to reduce ripple effects on the DC bus with small capacitors. The power required to be moved from the high voltage bus to the low voltage bus is input as a function of time, and the model determines the associated DC currents on each bus. Note the sign convention on the currents and power variables. The controller which supplies the power signal in watts must insure that the bus voltages are within desired ranges. Note that the currents are determined to conserve power and may become large as voltages are decreased by both this or other load paths. The model efficiency is independent of voltage difference between the buses. A more flexible efficiency model will be implemented soon.

**AC to AC Converter.** The AC-AC Converter block models a solid-state or conventional iron transformer for changing the voltage between two AC buses. This model is a simple power transformer with efficiency which accounts for the direction of power flow. It follows the same

convention used in the DC-DC converter. The power required to be moved from the high voltage bus to the low voltage bus is input as a function of time, and the model determines the associated DC currents on each bus. Note the sign convention on the currents and power variables. The controller which supplies the power signal in watts must insure that the bus voltages are within desired ranges. Note that the currents are determined to conserve power and may become large as voltages are decreased by both this and other load paths. The power transferred through this model assumes both buses are at a Power Factor of 1.

**Three-Phase Diode Rectifier.** This model performs direct rectification of three-phase AC voltage waveforms to DC assuming a full bridge of diodes. The model compares the voltage on each phase and outputs the difference between the maximum voltage and minimum voltage as the corresponding DC voltage. The model assumes perfect diode switching.

**Controlled Converter.** This model represents the actual switch hardware associated with a full bridge inverter-rectifier without its associated controller. The controllers are found in the Machines section. This model assumes a constant efficiency in the converter regardless of operating voltages, frequencies, and currents. A more advanced model is in development at this time.

**Three-Phase, Line-Commutated Inverter.** This block models a three-phase, variable frequency, variable voltage (based on input DC voltage level), line-commutated inverter assuming perfect, instantaneous switching (i.e., continuous voltage mode). There are no transients in the output voltage—all switching is assumed to occur instantaneously.

**Three-Phase, Pulse-Width Modulated, Voltage-Source Inverter.** This block models a three-phase, pulse-width modulated, voltage-source inverter. There are no transients in the output voltage—all switching is assumed to occur instantaneously. The higher-order harmonics in the voltage output are neglected. This implementation does not allow for rectifier-mode operation of the converter. The purpose of a three-phase, pulse-width modulated, voltage-source inverter is to use a DC voltage with a circuit containing IGBT's in order to produce a three-phase AC output voltage by modulating the switches appropriately. A reference AC voltage signal for each of the three-phases is a required input to the model, as is the resulting load currents across each of the three lines. The model output is the actual voltage across each of the three phases and the resulting DC load current.

### **Electrical Loads (See Figure 20)**

The DC Dump Resistor acts as a power sink for dumping energy from a DC bus. The model assumes that the requested average DC current will be achieved, except when this current exceeds the maximum possible current. This characteristic is based on the physical implementation of a chopper switch which controls the duty cycle of exposure of the dump resistor to the DC voltage. The limiting current is determined from the bus voltage and the resistance as the value when the duty cycle equals 1.0. The model also calculates the power loss (W) in the resistor.

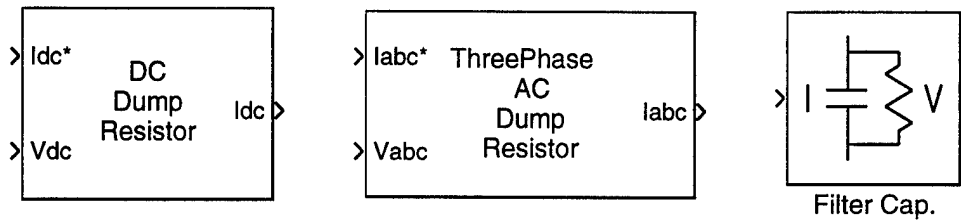

Figure 20. Electrical Load Model Library.

**Three-Phase AC Dump Resistor.** The AC Dump Resistor acts as a power sink for regenerative braking. The model assumes that the requested rms current will be achieved, except when this current exceeds the maximum possible current. The limiting current is determined from the bus line-to-line rms voltage and the resistance. The model also calculates the power loss (W) in the resistor.

**Filter Capacitor.** The Filter Capacitor models a parallel capacitor and resistor. This model can be used to define bus voltage for a low impedance DC system. The user is cautioned that the capacitance must be selected carefully in conjunction with the expected time steps and load currents to be imposed during the simulation to assure stable voltage.

## 8 Pulsed Power

This section describes two types of pulsed power model blocks (see Figure 21). The first is a rotating machine-based device or pulsed alternator. The second is a capacitor-based pulse forming network (PFN). The differences in their models are subtle but important in their behavior in the system. The pulsed alternator must be spun up prior to discharge but typically stores more than one discharge in its kinetic energy. The order to recharge itself typically comes after a shot. The PFN is typically a single-shot device which must be charged between shots. Charging is typically delayed until near the shot time to reduce the time at full charge and extend the life of the device. In this case, charging commands come prior to the discharge event.

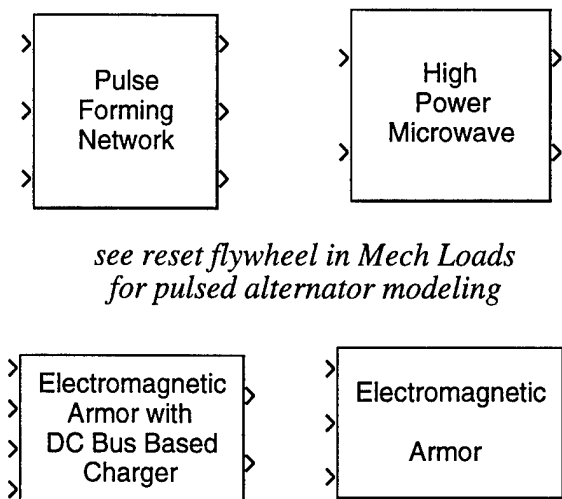

Figure 21. Pulsed Power Model Library.

### Pulsed Alternator

The pulsed alternator model characterizes the charge and discharge of the kinetic energy stored in its rotating mass. The model used here incorporates a permanent magnet drive motor coupled to a flywheel-type mass. A net charging efficiency is applied to the PM machine. The discharge is modeled as a step change in the state of the machine/flywheel in the form of a reduction in speed of the rotating mass. This speed reduction is correlated with the energy specified for the discharge which is an input along with the discharge trigger signal. The charge command is a signal (0-1) which is scaled with the charger power rating to determine the operating point for the motor.

### Pulse Forming Network

The Pulse Forming Network (PFN) model is basically a model for its capacitive element and associated charging electronics. It takes as an input the desired capacitor-charging current at each time step and imposes a simple linear capacitance law in determining the stored energy and voltage associated with the capacitor. It derives from transforming action with some efficiency loss. The equivalent current is drawn from the DC bus to which it is assumed to be connected. The charging circuitry is assumed to perform the required step-up or step-down voltage transformation to match the capacitor voltage at each time step and conserve energy in the system. A bounding current is imposed on the charge cycle to prevent damaging currents from being imposed on the capacitor by an uncompensating control system. As with the Pulsed Alternator model, the discharge phase of the PFN operation is assumed to occur at a fraction of a time step and therefore may be modeled with a step change in the storage capacity of the capacitor. Since we currently consider that the capacitor will be discharged completely for each shot, the state of the capacitor is set to zero following a shot. The block outputs its state of charge and voltage for use by appropriate control systems and triggers. The PFN block does not limit the current when the capacitor is fully charged. It relies on the controller to sense this condition and set the desired current appropriately. Nonlinear capacitors have yet to be modeled but can be

rather easily if the relationship between capacitance and voltage or voltage and coulombs is known.

### **High Powered Microwave**

The High Powered Microwave (HPM) block models the power supply draw from the system for running this weapon system. It is meant to be driven from a high voltage DC source and it will impose pulsed current loads on such a source. Note that it is the user's responsibility to insure that the DC supply can deliver these current pulses and maintain its voltage within design conditions. The HPM model will only draw current if its source voltage is within a certain bandwidth (80 to 113 kV). The HPM requires a signal (0 or 1) from a trigger device to signal when it should be operating. When operational, the HPM will extract current at the level required to maintain a certain peak pulsed power over the prescribed duty cycle of the device. In this first block, the duty cycle is 0.5 seconds peak power, followed by 1 second zero power, then repeat.

### **Electromagnetic Armor with DC Bus-Based Charger**

This block models the power draw of an electromagnetic (EM) armor system and includes a DC-DC converter for charging the armor. The armor is assumed to consist of a capacitor driven EM inductive launcher or capacitor discharge defeat mechanism. This capacitor is discharged when the armor is triggered, and a latent negative voltage may result from inductive current flow in the later part of the armor discharge. This model assumes that this negative voltage can be used in subsequent armor discharges by reversing the polarity of the charging circuit and making sure that the discharge circuit is insensitive to polarity. Also included in this model is a dump resistor which may be used at any time to dump the energy stored in the capacitor as might be appropriate for capacitance discharge defeat mechanisms.

### **Electromagnetic Armor**

This block is just like the EM Armor model described above except it assumes the user is not using a standard DC-DC converter to supply the charge current. The user must pull the current from some other model.

## **9 Missions**

The mission specification, contained in the three blocks shown in Figure 22, must contain all relevant external inputs required to exercise the vehicle in a desired fashion. Such information normally includes all input effected by the driver and all characteristics of the terrain over which the vehicle is assumed to operate. Ideally, the mission specification would also contain the initial condition for each state in the model; however, the implementation here has not developed to that point.

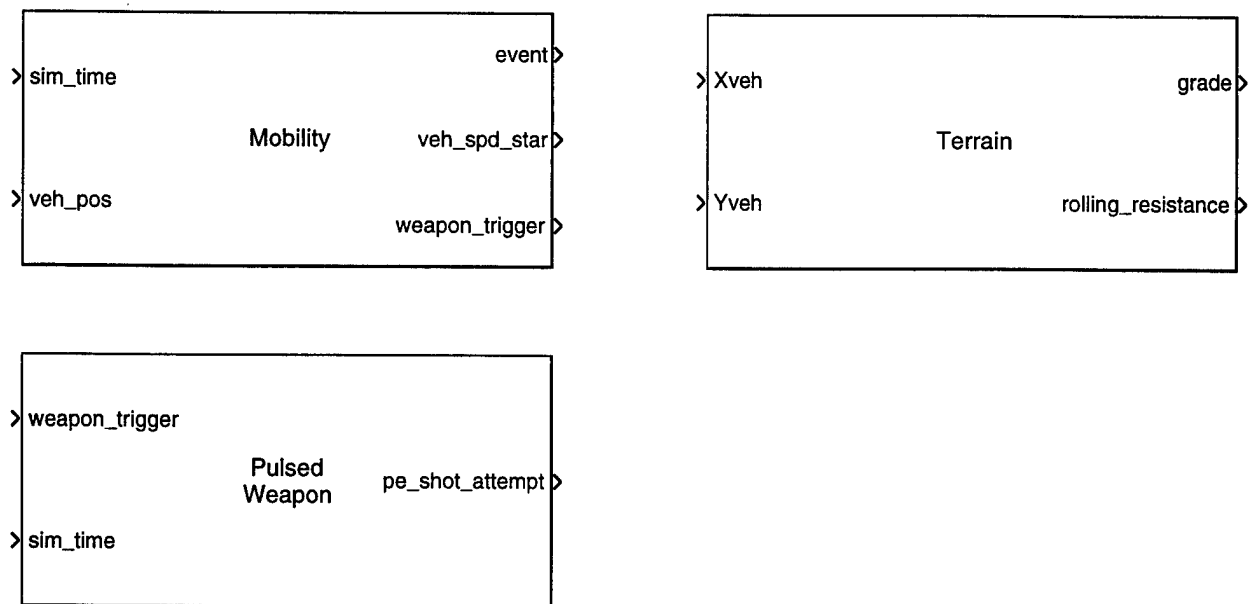

Figure 22. Mission Library.

In an effort to allow sharing of mission specification data, a standard mission format was developed for use by those performing simulation studies in connection with DARPA-funded vehicle development contracts. Please refer to the User's Guide for IMPACT [2] for detailed description of the standard mission format.

### Mobility

The purpose of the mission mobility block is to specify a reference velocity and mode of operation as a function of simulation time and/or vehicle position throughout the simulation. In addition, this block provides functionality to trigger a non-mobility event in synchronization with the beginning of a mobility event. The implementation provided in the toolbox allows for reference speed and weapon event triggering only. Future implementations may include operating mode and the ability to trigger non-mobility events other than the weapon.

### Pulsed Weapon

The weapon block included in the IMPACT Missions library is an implementation of a command generator for a pulsed weapon. The input to the block is the weapon\_trigger signal from the mission mobility block and the current simulation time. The output of this block is the magnitude of energy required for the current shot. Each shot signal is for one time step only.

Each shot sequence (i.e., weapon event) is time based and begins when a nonzero signal is received from the mission mobility block via weapon\_trigger. The shot sequence continues through the last shot unless it is interrupted by another trigger signal before the current shot sequence has finished.

## **Terrain**

The terrain block calculates the local gradient and rolling resistance required by the vehicle dynamics model. It does so by a 2-D interpolation in a terrain map defined by the X- and Y-position of the vehicle in meters.

## **Acknowledgment**

This work was supported by the U.S. Army Research Laboratory (ARL) and the Defense Advanced Research Projects Agency (DARPA) under contract DAAA21-93-C-0101.

## **References**

- [1] *MATLAB<sup>®</sup> High Performance Numeric Computation and Visualization Software*. The MathWorks, Inc., Natick, Mass.
- [2] *Users Guide for IMPACT*. IAT.M 0007, University of Texas at Austin, Institute for Advanced Technology, Austin, Tex.
- [3] R.H. Park. Two-reaction theory of synchronous machines-generalized method of analysis, part i. *AIEE Transactions*, 48:716-727, July 1929.
- [4] O. Wasynczuk and S.D. Sudhoff. A maximum torque per ampere control strategy for induction motor drives. *IEEE Transactions on Energy Conversion*, April 1997.

## Distribution List

Administrator  
Defense Technical Information Center  
Attn: DTIC-DDA  
8725 John J. Kingman Road,  
Ste 0944  
Ft. Belvoir, VA 22060-6218

Dr. Marilyn Freeman  
DARPA/TTO  
3701 N. Fairfax Drive  
Arlington, VA 22203-1714

Director  
US Army Research Lab  
ATTN: AMSRL OP SD TA  
2800 Powder Mill Road  
Adelphi, MD 20783-1145

William Jones  
HQ, US Army TRADOC  
DCSCD  
Ft. Monroe, VA 23651-5000

Director  
US Army Research Lab  
ATTN: AMSRL OP SD TL  
2800 Powder Mill Road  
Adelphi, MD 20783-1145

Mr. Dennis Ladd  
Commander, TACOM-ARDEC  
ATTN: AMSTA-AR-FSP-E / Dennis Ladd  
Bldg. 354  
Picatinny Arsenal, NJ 07806-5000

Director  
US Army Research Lab  
ATTN: AMSRL OP SD TP  
2800 Powder Mill Road  
Adelphi, MD 20783-1145

John Lewis  
US Army TACOM-TARDEC  
Attn: AMSTA-TR-D, MS 207  
Warren, MI 48397-5000

Army Research Laboratory  
AMSRL-CI-LP  
Technical Library 305  
Aberdeen Prvg Grd, MD 21005-5066

Dr. Edward M. Schmidt  
U.S. Army Research Laboratory  
AMSRL-WM-B  
Aberdeen Prvg Grd, MD 21005-5066

Mr. Dave Bauer  
IAP Research, Incorporated  
2763 Culver Avenue  
Dayton, OH 45429-3723

Munira Tournier  
US Army TACOM-TARDEC  
Attn: AMSTA-TR-D, MS 207  
Warren, MI 48397-5000

Douglas K. Brabston  
Project Officer, Mounted Systems Div.  
US Army Infantry Center  
ATTN: ATZB-CDM  
Fort Benning, GA 31905-5400

Mr. Alan Walls  
Center for Electromechanics  
The University of Texas at Austin  
BRC EME 133  
10100 Burnet Rd.  
Austin, TX 78758-4497

John Butler  
Directorate of Combat Development  
Attn: ATZK-CD  
U.S. Army Armor Center and School  
Fort Knox, KY 40121-5000

Wayne Wheelock  
Director  
US Army Tank Automotive and Armament  
Command  
Bldg. 212, MS 121  
Warren, MI 48397-5000