

8

NATIONAL ADVISORY COMMITTEE FOR AERONAUTICS

TECHNICAL NOTE

No. 1798

EFFECT OF THICKNESS ON THE LATERAL FORCE
AND YAWING MOMENT OF A SIDESLIPPING
DELTA WING AT SUPERSONIC SPEEDS

By Kenneth Margolis

Langley Aeronautical Laboratory
Langley Air Force Base, Va.



Washington

January 1949

Reproduced From
Best Available Copy

20000808 144

NATIONAL ADVISORY COMMITTEE FOR AERONAUTICS

TECHNICAL NOTE NO. 1798

EFFECT OF THICKNESS ON THE LATERAL FORCE
AND YAWING MOMENT OF A SIDESLIPPING
DELTA WING AT SUPERSONIC SPEEDS

By Kenneth Margolis

SUMMARY

Calculations, based on linearized supersonic-flow theory and on the additional assumption that the Mach cones yaw with the wing, are made to determine the effect of thickness on the lateral force and yawing moment of a sideslipping delta wing at supersonic speeds. Generalized equations are derived for delta wings with rhombic profile and constant thickness ratio. Results indicate that, for wings suitable for supersonic flight, the contribution of wing thickness to the stability derivatives $C_{Y\beta}$ and $C_{n\beta}$ (rates of change of lateral-force and yawing-moment coefficients with angle of sideslip) is small in comparison with the effects that may be expected from a vertical tail.

INTRODUCTION

Theoretical investigations of supersonic stability derivatives of isolated wings have been confined chiefly to the treatment of mathematically thin profiles (flat plates). Finite thickness will have certain effects, some of which can be estimated by consideration of small perturbations. The purpose of the present paper is to present some calculations showing the effect of thickness on the lateral-force and yawing-moment derivatives of a sideslipping delta wing at supersonic speeds.

On the basis of linearized theory, equations are developed for the stability derivatives $C_{Y\beta}$ and $C_{n\beta}$ (derivatives of lateral force and yawing moment with respect to sideslip) as functions of thickness ratio, aspect ratio, and Mach number for delta wings at zero lift. The airfoil sections parallel to the plane of symmetry are rhombuses, that is, symmetrical double wedges with maximum thickness at 50 percent chord, and are of constant thickness ratio.

In the analysis the Mach cones were assumed to yaw with the wing. This additional approximation introduces considerable mathematical simplifications into the problem. The assumption of the yawed Mach cones raises a question as to the quantitative validity of the results. Although verification of these quantitative results must await a more exact analysis, the qualitative results of the present investigation are believed to bring out the salient characteristics and significance of the thickness effects.

Generalized curves are presented to permit estimation of the derivatives for any specific delta wing. Series of curves giving variations of the derivatives with Mach number for various aspect ratios are also presented.

SYMBOLS

General:

x, y, z	Cartesian coordinates
V	flight velocity
u	incremental disturbance velocity parallel to x-axis
w	incremental disturbance velocity parallel to z-axis
ρ	density of air
Δp	pressure increment caused by disturbance
q	dynamic pressure $\left(\frac{1}{2}\rho V^2\right)$
ϕ	disturbance-velocity potential
M	Mach number
$B = \sqrt{M^2 - 1}$	
a	root semichord, measured in plane of wing symmetry
c	chord length at spanwise station y , measured in a plane parallel to plane of wing symmetry
t	maximum thickness of section with chord c at spanwise station y
Λ	angle of sweep of leading edge
m	slope of wing leading edge $(\cot \Lambda)$
b	span of wing
S	wing area
A	aspect ratio $\left(\frac{b^2}{S} = 4 \cot \Lambda\right)$

$$\mu = \cot \Lambda \sqrt{M^2 - 1} = \frac{A}{4} \sqrt{M^2 - 1}$$

β angle of sideslip

Y lateral force

N yawing moment

C_Y lateral-force coefficient $\left(\frac{Y}{\frac{1}{2}\rho V^2 S} \right)$

C_n yawing-moment coefficient $\left(\frac{N}{\frac{1}{2}\rho V^2 S b} \right)$

R.P. real part

Stability derivatives:

$$C_{Y\beta} = \left(\frac{\partial C_Y}{\partial \beta} \right)_{\beta \rightarrow 0}$$

$$C_{n\beta} = \left(\frac{\partial C_n}{\partial \beta} \right)_{\beta \rightarrow 0}$$

Subscripts:

$()_x$ yawing moment contribution (taken about wing apex)
due to lateral forces multiplied by x moment arms

$()_y$ yawing moment contribution (taken about wing apex)
due to longitudinal forces multiplied by y moment arms

β indicates velocity taken in flight direction,
except when used for stability-derivative
notation defined previously

ANALYSIS

The analysis is based on the linearized theory of supersonic flow and the derivation of equations and application of results are therefore subject to the usual limitations and restrictions of the theory. In order to minimize the mathematical complexities, all pertinent equations are

derived specifically for a delta plan form with rhombic profile. The method is applicable, however, to wings of arbitrary plan form and profile.

Consider the delta wing shown in figure 1(a). The wing is moving in a direction parallel to the axis of symmetry, that is, at zero lift and zero sideslip. The incremental disturbance velocity parallel to the x-axis, u , is readily obtained by methods outlined in references 1 to 3. The equation is

$$u = \frac{\partial \phi}{\partial x} = \text{R.P.} \frac{mV}{\pi} \left[\frac{w_1}{V \sqrt{1 - m^2 B^2}} \left(\cosh^{-1} \frac{x - mB^2 y}{B|y - mx|} + \cosh^{-1} \frac{x + mB^2 y}{B|y + mx|} \right) + \frac{2w_2}{V \sqrt{1 - 4m^2 B^2}} \left(\cosh^{-1} \frac{x - a - 2mB^2 y}{B|y - 2m(x-a)|} + \cosh^{-1} \frac{x - a + 2mB^2 y}{B|y + 2m(x-a)|} \right) \right] \quad (1)$$

where $\frac{w_1}{V}$ and $\frac{w_2}{V}$ for the forward wedge and rearward wedge, respectively, are found as follows:

$$\left. \begin{aligned} \frac{w_1}{V} &= \frac{t}{c} \\ \frac{w_2}{V} &= -2\frac{t}{c} \end{aligned} \right\} \quad (2)$$

It should be noted that equation (1) is applicable to other Mach line configurations as well as for that shown in figure 1.

Now consider the same wing sideslipping to the right at a small angle β . (See fig. 1(b).) The Mach cone is assumed to retain the same position relative to the wing for both the straight-flight and the sideslipping condition. This assumption follows from consideration of the discussion given in reference 4. The expression for u for the sideslipping wing is still given by equation (1) except that other values are required for $\frac{w_1}{V}$ and $\frac{w_2}{V}$. For small angles of sideslip these values are approximately as follows:

For the right half-wing,

$$\left. \begin{aligned} \frac{w_1}{V} &= \frac{t}{c} (1 + \beta \tan \Lambda) \\ \frac{w_2}{V} &= -\frac{t}{c} (2 + \beta \tan \Lambda) \end{aligned} \right\} \quad (3a)$$

and for the left half-wing,

$$\left. \begin{aligned} \frac{w_1}{V} &= \frac{t}{c}(1 - \beta \tan \Lambda) \\ \frac{w_2}{V} &= -\frac{t}{c}(2 - \beta \tan \Lambda) \end{aligned} \right\} \quad (3b)$$

For the sideslipping condition, equation (1) becomes

$$\begin{aligned} \frac{\partial \phi}{\partial x} = \text{R.P.} \frac{mV}{\pi} \frac{t}{c} & \left[\frac{(1 + \beta \tan \Lambda)}{\sqrt{1 - m^2 B^2}} \cosh^{-1} \frac{x - mB^2 y}{B|y - mx|} \right. \\ & + \frac{(1 - \beta \tan \Lambda)}{\sqrt{1 - m^2 B^2}} \cosh^{-1} \frac{x + mB^2 y}{B|y + mx|} - \frac{2(2 + \beta \tan \Lambda)}{\sqrt{1 - 4m^2 B^2}} \cosh^{-1} \frac{x - a - 2mB^2 y}{B|y - 2m(x-a)|} \\ & \left. - \frac{2(2 - \beta \tan \Lambda)}{\sqrt{1 - 4m^2 B^2}} \cosh^{-1} \frac{x - a + 2mB^2 y}{B|y + 2m(x-a)|} \right] \quad (4) \end{aligned}$$

The disturbance velocity in the flight direction u_β (positive forward) may be expressed in terms of components along and perpendicular to the axis of wing symmetry, $\frac{\partial \phi}{\partial x}$ and $\frac{\partial \phi}{\partial y}$. The relation is

$$u_\beta = \frac{\partial \phi}{\partial x} - \beta \frac{\partial \phi}{\partial y} \quad (5)$$

The increment in pressure caused by the disturbance is obtained from

$$\Delta p = \rho V u_\beta \quad (6)$$

which expresses Bernoulli's law with the approximation of small disturbances.

From equations (5) and (6), the pressure coefficient $\frac{\Delta p}{q}$ for one surface of the sideslipping delta wing is found to be

$$\frac{\Delta p}{q} = \frac{2}{V} \left(\frac{\partial \phi}{\partial x} - \beta \frac{\partial \phi}{\partial y} \right) \quad (7)$$

The expression for $\frac{\partial \phi}{\partial x}$ is given in equation (4); the term $\frac{\partial \phi}{\partial y}$ may be obtained in the following manner:

$$\frac{\partial \phi}{\partial y} = \frac{\partial}{\partial y} \int_{-\infty}^x \frac{\partial \phi}{\partial x} dx \quad (8)$$

The expression for $\frac{\partial \phi}{\partial y}$ is therefore

$$\begin{aligned} \frac{\partial \phi}{\partial y} = \text{R.P.} \frac{2}{\pi} \frac{V t}{c} & \left[\frac{1 - \beta \tan \Lambda}{2 \sqrt{1 - m^2 B^2}} \cosh^{-1} \frac{x + mB^2 y}{B|mx + y|} \right. \\ & - \frac{1 + \beta \tan \Lambda}{2 \sqrt{1 - m^2 B^2}} \cosh^{-1} \frac{x - mB^2 y}{B|mx - y|} + \beta \tan \Lambda \left(\cosh^{-1} \frac{x}{|yB|} - \cosh^{-1} \frac{x - a}{|yB|} \right) \\ & - \frac{2 - \beta \tan \Lambda}{2 \sqrt{1 - 4m^2 B^2}} \cosh^{-1} \frac{x - a + 2mB^2 y}{B|2m(x - a) + y|} \\ & \left. + \frac{2 + \beta \tan \Lambda}{2 \sqrt{1 - 4m^2 B^2}} \cosh^{-1} \frac{x - a - 2mB^2 y}{B|2m(x - a) - y|} \right] \quad (9) \end{aligned}$$

Performing the operations indicated in equation (7) and neglecting all terms of order β^2 and higher gives the following simplified expression for the pressure coefficient of the sideslipping delta wing:

$$\begin{aligned} \frac{\Delta p}{q} = \text{R.P.} \frac{2}{\pi} \frac{t}{c} & \left[\frac{m + 2\beta}{\sqrt{1 - m^2 B^2}} \cosh^{-1} \frac{x - mB^2 y}{B|y - mx|} + \frac{m - 2\beta}{\sqrt{1 - m^2 B^2}} \cosh^{-1} \frac{x + mB^2 y}{B|y + mx|} \right. \\ & \left. - \frac{4(m + \beta)}{\sqrt{1 - 4m^2 B^2}} \cosh^{-1} \frac{x - a - 2mB^2 y}{B|y - 2m(x-a)|} - \frac{4(m - \beta)}{\sqrt{1 - 4m^2 B^2}} \cosh^{-1} \frac{x - a + 2mB^2 y}{B|y + 2m(x-a)|} \right] \quad (10) \end{aligned}$$

The lateral-force and yawing-moment coefficients may then be obtained by appropriate integrations over the entire wing area, thus,

$$C_Y = \frac{Y}{\frac{1}{2} \rho V^2 S} = \frac{2}{S} \iint \frac{\Delta p}{q} \frac{dz}{dy} dx dy \quad (11)$$

and

$$C_n = \frac{N}{\frac{1}{2}\rho V^2 S b} = \frac{2}{S b} \left[- \iint \frac{\Delta p}{q} \frac{dz}{dy} x \, dx \, dy + \iint \frac{\Delta p}{q} \frac{dz}{dx} y \, dx \, dy \right] \quad (12)$$

where, for convenience, the moments are taken about the wing apex and are considered positive for clockwise rotation. The factor of 2 accounts for the equal additive contribution of the upper and lower surfaces. Information pertinent to the limits of integration is shown in figure 2. The integral expressions for C_Y are presented in appendix A and those for C_n in appendixes B and C. Appendix B presents the first term on the right-hand side of equation (12) which is designated $(C_n)_x$; appendix C presents the second term, which is designated $(C_n)_y$.

The indicated integrations were performed and the resulting expressions for the stability derivative $C_{Y\beta}$ and for the derivatives $(C_{n\beta})_x$ and $(C_{n\beta})_y$ are given as functions of μ in table I.

For moments taken about an arbitrary point x_0 an expression for $C_{n\beta}$ may readily be derived as

$$C_{n\beta} = (C_{n\beta})_x + (C_{n\beta})_y + \frac{2}{A} \frac{x_0}{c} C_{Y\beta} \quad (13)$$

Values of the stability derivative $C_{n\beta}$ are then obtained by adding the previously derived right-hand members of equation (13).

RESULTS AND DISCUSSION

It was pointed out in the introduction that the assumption of yawed Mach cones raises a question as to the quantitative validity of the results. The small triangular regions of the wing between the assumed (yawed) position of the Mach cones and the correct (unyawed) position have an area proportional to the sideslip angle β . It appears that the basic pressure for $\beta = 0$ acting on these small triangular regions may make a contribution to the stability derivatives $C_{Y\beta}$ and $C_{n\beta}$ that is of the same order of magnitude as that produced by the increment in pressure due to β acting over the entire wing. The quantitative results obtained herein must therefore be considered as rough approximations. The qualitative results, however, which represent the more important consideration of the present investigation, are believed to bring out the salient characteristics and significance of the thickness effects.

Stability derivative $C_{Y\beta}$.- A generalized curve showing the variation

of $A \frac{C_{Y\beta}}{(t/c)^2}$ with μ where $\mu = \frac{A}{4} \sqrt{M^2 - 1}$ is presented in figure 3. It

should be noted that the two discontinuities in slope evident in figure 3 (also in figs. 4 to 6) occur when the Mach lines are parallel to the maximum-thickness line and to the leading edge. For any given values of aspect ratio, Mach number, and thickness ratio, the stability derivative $C_{Y\beta}$ is readily obtained by use of this single curve. Variations

of $\frac{C_{Y\beta}}{(t/c)^2}$ with Mach number for various aspect ratios are presented in

figure 4. The contribution of wing thickness to the value of $C_{Y\beta}$ for suitable supersonic wings (10 percent thick or less) is found to be small in comparison with the value of $C_{Y\beta}$ that may be expected from a vertical tail.

Stability derivative $C_{n\beta}$.- Generalized curves showing the variations

of $A^2 \frac{(C_{n\beta})_x}{(t/c)^2}$ and $\frac{(C_{n\beta})_y}{(t/c)^2}$ with μ are shown in figures 5(a) and 5(b),

respectively. For any given set of parameters, the stability derivative $C_{n\beta}$ is obtained by proper use of figures 4 and 5 and equation (13).

Variations of $\frac{C_{n\beta}}{(t/c)^2}$ (moments taken about the $\frac{2}{3}$ -chord point) with Mach

number for various aspect ratios are presented in figure 6. As with $C_{Y\beta}$, the contribution of wing thickness to $C_{n\beta}$ for wings of small thickness is seen to be small compared with the expected contribution of a vertical tail, although for some airplane designs the value of $C_{n\beta}$ due to thickness may be appreciable when compared with the value of $C_{n\beta}$ for the complete airplane.

CONCLUDING REMARKS

On the basis of linearized theory, calculations have been made to determine the effect of thickness on the lateral force and yawing moment of a sideslipping delta wing at supersonic speeds. Results indicate that, for wings suitable for supersonic flight, the contribution of wing thickness to the values of $C_{Y\beta}$ and $C_{n\beta}$ is small in comparison with the effects that may be expected from a vertical tail, although for some airplane designs the value of $C_{n\beta}$ due to wing thickness may be appreciable when compared to the value of $C_{n\beta}$ for the complete airplane.

Langley Aeronautical Laboratory
National Advisory Committee for Aeronautics
Langley Air Force Base, Va., October 6, 1948

APPENDIX A

INTEGRAL EXPRESSIONS FOR C_Y

The integral expressions for C_Y for the cases indicated in figure 2 are as follows:

Case I ($0 \leq \mu \leq \frac{1}{2}$):

$$\frac{\pi a^2 m^2}{4\beta(t/c)^2} C_Y = - \frac{1}{\sqrt{1 - m^2 B^2}} \int_0^{2am} \int_{y/m}^{\frac{y+2am}{2m}} A \, dx \, dy$$

$$+ \frac{2}{\sqrt{1 - 4m^2 B^2}} \left(\int_0^{\frac{am}{1-mB}} \int_{By+a}^{\frac{y+2am}{m}} C \, dx \, dy + \int_{\frac{am}{1-mB}}^{2am} \int_{y/m}^{\frac{y+2am}{2m}} C \, dx \, dy \right)$$

where

$$A = \cosh^{-1} \frac{x - mB^2 y}{B|y - mx|} - \cosh^{-1} \frac{x + mB^2 y}{B|y + mx|}$$

and

$$C = \cosh^{-1} \frac{x - a - 2mB^2 y}{B|y - 2m(x - a)|} - \cosh^{-1} \frac{x - a + 2mB^2 y}{B|y + 2m(x - a)|}$$

Case II ($\frac{1}{2} < \mu \leq 1$):

$$\frac{\pi a^2 m^2}{4\beta(t/c)^2} C_Y = - \frac{1}{\sqrt{1 - m^2 B^2}} \int_0^{2am} \int_{y/m}^{\frac{y+2am}{2m}} A \, dx \, dy$$

where A is the function defined for case I.

Case III ($\mu > 1$):

$$\frac{\pi a^2 m^2}{4\beta(t/c)^2} C_Y = - \frac{1}{\sqrt{m^2 B^2 - 1}} \left(\int_0^{\frac{2am}{2mB-1}} \int_{y/m}^{yB} \pi \, dx \, dy \right. \\ \left. + \int_{\frac{2am}{2mB-1}}^{2am} \int_{y/m}^{\frac{y+2am}{2m}} \pi \, dx \, dy + \int_0^{\frac{2am}{2mB-1}} \int_{yB}^{\frac{y+2am}{2m}} D \, dx \, dy \right)$$

where

$$D = \cos^{-1} \frac{x - mB^2 y}{B|y - mx|} - \cos^{-1} \frac{x + mB^2 y}{B|y + mx|}$$

APPENDIX B

INTEGRAL EXPRESSIONS FOR $(C_n)_x$

Integral expressions for the yawing-moment contribution $(C_n)_x$ for the three cases shown in figure 2 are as follows:

Case I $(0 \leq \mu \leq \frac{1}{2})$:

$$\frac{\pi a^3 m^3}{\beta(t/c)^2} (C_n)_x = - \frac{1}{\sqrt{1 - m^2 B^2}} \int_0^{2am} \int_{y/m}^{\frac{y+2am}{2m}} Ax \, dx \, dy$$

$$+ \frac{2}{\sqrt{1 - 4m^2 B^2}} \left(\int_0^{am} \int_{\frac{y+2am}{2m}}^{\frac{y+2am}{2m}} Cx \, dx \, dy + \int_{\frac{am}{1-mB}}^{2am} \int_{y/m}^{\frac{y+2am}{2m}} Cx \, dx \, dy \right)$$

where

$$A = \cosh^{-1} \frac{x - mB^2 y}{B|y - mx|} - \cosh^{-1} \frac{x + mB^2 y}{B|y + mx|}$$

and

$$C = \cosh^{-1} \frac{x - a - 2mB^2 y}{B|y - 2m(x - a)|} - \cosh^{-1} \frac{x - a + 2mB^2 y}{B|y + 2m(x - a)|}$$

Case II $(\frac{1}{2} < \mu \leq 1)$:

$$\frac{\pi a^3 m^3}{\beta(t/c)^2} (C_n)_x = - \frac{1}{\sqrt{1 - m^2 B^2}} \int_0^{2am} \int_{y/m}^{\frac{y+2am}{2m}} Ax \, dx \, dy$$

where A is the function defined for case I.

Case III ($\mu > 1$):

$$\frac{\pi a^3 m^3}{\beta (t/c)^2} (C_n)_x = - \frac{1}{\sqrt{m^2 B^2 - 1}} \left(\int_0^{\frac{2am}{2mB-1}} \int_{y/m}^{yB} \pi x \, dx \, dy \right. \\ \left. + \int_{\frac{2am}{2mB-1}}^{2am} \int_{y/m}^{\frac{y+2am}{2m}} \pi x \, dx \, dy + \int_0^{\frac{2am}{2mB-1}} \int_{yB}^{\frac{y+2am}{2m}} D x \, dx \, dy \right)$$

where

$$D = \cos^{-1} \frac{x - mB^2 y}{B|y - mx|} - \cos^{-1} \frac{x + mB^2 y}{B|y + mx|}$$

APPENDIX C

INTEGRAL EXPRESSIONS FOR $(C_n)_y$

Integral expressions for the yawing-moment contribution $(C_n)_y$ for the cases shown in figure 2 are as follows:

Case I $(0 \leq \mu \leq \frac{1}{2})$:

$$\begin{aligned} \frac{\pi a^3 m^2}{\beta(t/c)^2} (C_n)_y = & \frac{1}{\sqrt{1 - m^2 B^2}} \left(\int_0^{2am} \int_{y/m}^{\frac{y+2am}{2m}} A_y \, dx \, dy - \int_0^{2am} \int_{\frac{y+2am}{2m}}^{2a} A_y \, dx \, dy \right) \\ & + \frac{2}{\sqrt{1 - 4m^2 B^2}} \left(\int_0^{2am} \int_{\frac{y+2am}{2m}}^{2a} C_y \, dx \, dy \right. \\ & \left. - \int_{\frac{am}{1-mB}}^{2am} \int_{y/m}^{\frac{y+2am}{2m}} C_y \, dx \, dy - \int_0^{\frac{am}{1-mB}} \int_{By+a}^{\frac{y+2am}{2m}} C_y \, dx \, dy \right) \end{aligned}$$

where

$$A = \cosh^{-1} \frac{x - mB^2 y}{B|y - mx|} - \cosh^{-1} \frac{x + mB^2 y}{B|y + mx|}$$

and

$$C = \cosh^{-1} \frac{x - a - 2mB^2 y}{B|y - 2m(x - a)|} - \cosh^{-1} \frac{x - a + 2mB^2 y}{B|y + 2m(x - a)|}$$

Case II $\left(\frac{1}{2} < \mu \leq 1\right)$:

$$\begin{aligned} \frac{\pi a^3 m^2}{\beta(t/c)^2} (C_n)_y &= \frac{1}{\sqrt{1 - m^2 B^2}} \left(\int_0^{2am} \int_{y/m}^{\frac{y+2am}{2m}} A_y \, dx \, dy - \int_0^{2am} \int_{\frac{y+2am}{2m}}^{2a} A_y \, dx \, dy \right) \\ &+ \frac{2}{\sqrt{4m^2 B^2 - 1}} \left(\int_0^{a/B} \int_{\frac{y+2am}{2m}}^{yB+a} \pi y \, dx \, dy + \int_0^{a/B} \int_{yB+a}^{2a} E_y \, dx \, dy \right. \\ &\left. + \int_{a/B}^{2am} \int_{\frac{y+2am}{2m}}^{2a} \pi y \, dx \, dy \right) \end{aligned}$$

where A is the function defined for case I and

$$E = \cos^{-1} \frac{x - a - 2mB^2 y}{B|y - 2m(x - a)|} - \cos^{-1} \frac{x - a + 2mB^2 y}{B|y + 2m(x - a)|}$$

Case III ($\mu > 1$):

$$\frac{\pi a^3 m^2}{\beta (t/c)^2} (C_n)_y = \frac{1}{\sqrt{m^2 B^2 - 1}} \left(\int_0^{\frac{2am}{2mB-1}} \int_{y/m}^{yB} \pi y \, dx \, dy \right. \\ + \int_{\frac{2am}{2mB-1}}^{2am} \int_{y/m}^{\frac{y+2am}{2m}} \pi y \, dx \, dy - \int_{\frac{2am}{2mB-1}}^{2a/B} \int_{\frac{y+2am}{2m}}^{yB} \pi y \, dx \, dy - \int_{2a/B}^{2am} \int_{\frac{y+2am}{2m}}^{2a} \pi y \, dx \, dy \\ + \int_0^{\frac{2am}{2mB-1}} \int_{yB}^{\frac{y+2am}{2m}} Dy \, dx \, dy - \int_0^{\frac{2am}{2mB-1}} \int_{\frac{y+2am}{2m}}^{2a} Dy \, dx \, dy - \left. \int_{\frac{2am}{2mB-1}}^{2a/B} \int_{yB}^{2a} Dy \, dx \, dy \right) \\ + \frac{2}{\sqrt{4m^2 B^2 - 1}} \left(\int_0^{a/B} \int_{\frac{y+2am}{2m}}^{\frac{yB+a}{2m}} \pi y \, dx \, dy + \int_0^{a/B} \int_{yB+a}^{2a} Ey \, dx \, dy \right. \\ \left. + \int_{a/B}^{2am} \int_{\frac{y+2am}{2m}}^{2a} \pi y \, dx \, dy \right)$$

where E is the function defined for case II and

$$D = \cos^{-1} \frac{x - mB^2 y}{B|y - mx|} - \cos^{-1} \frac{x + mB^2 y}{B|y + mx|}$$

REFERENCES

1. Jones, Robert T.: Thin Oblique Airfoils at Supersonic Speed.
NACA Rep.No. 851, 1946.
2. Puckett, Allen E.: Supersonic Wave Drag of Thin Airfoils. Jour.
Aero. Sci., vol. 13, no. 9, Sept. 1946, pp. 475-484.
3. Margolis, Kenneth: Supersonic Wave Drag of Sweptback Tapered Wings
at Zero Lift. NACA TN No. 1448, 1947.
4. Ribner, Herbert S., and Malvestuto, Frank S., Jr.: Stability
Derivatives of Triangular Wings at Supersonic Speeds.
NACA TN No. 1572, 1948, p. 8.

TABLE I
 FORMULAS FOR LATERAL-FORCE AND YAWING-MOMENT DERIVATIVES

μ	$\frac{3\pi A}{64(t/c)^2} C_{Y\beta}$	$\frac{9\pi A^2}{64(t/c)^2} (C_{N\beta})_x$	$\frac{9\pi A^2}{4(t/c)^2} (C_{N\beta})_y$
0	0	$-2 \log_6 2$	3
$0 < \mu < \frac{1}{2}$	$\frac{1}{\sqrt{1-\mu^2}} \log_6 \frac{1-2\mu^2 + \sqrt{(1-\mu^2)(1-4\mu^2)}}{\mu(1+\sqrt{1-\mu^2})}$ $- \frac{1}{\sqrt{1-4\mu^2}} \log_6 \frac{1-2\mu^2 + \sqrt{(1-\mu^2)(1-4\mu^2)}}{\mu(1+\sqrt{1-4\mu^2})}$	$\frac{8\mu^2 - 11}{3(1-\mu^2)^{3/2}} \log_6 \frac{1-2\mu^2 + \sqrt{(1-\mu^2)(1-4\mu^2)}}{\mu}$ $- \frac{11}{3\sqrt{1-4\mu^2}} \log_6 2\mu - \frac{\sqrt{1-4\mu^2}}{1-\mu^2}$ $+ \frac{8}{3\sqrt{1-\mu^2}} \log_6 (1 + \sqrt{1-\mu^2})$ $- \frac{4(11\mu^2 - 2)}{3(1-4\mu^2)^{3/2}} \log_6 \frac{2-4\mu^2 + 2\sqrt{(1-\mu^2)(1-4\mu^2)}}{1 + \sqrt{1-4\mu^2}}$ $- \frac{1-2\sqrt{1-\mu^2}}{1-4\mu^2}$	$\frac{8}{3\sqrt{1-\mu^2}} \log_6 (1 + \sqrt{1-\mu^2}) - \frac{3\pi}{2\mu}$ $- \frac{\sqrt{1-4\mu^2}}{1-\mu^2} + \frac{5\mu^2 - 8}{3(1-\mu^2)^{3/2}} \operatorname{cosech}^{-1} \frac{1-2\mu^2}{\mu}$ $+ \frac{4(2\sqrt{1-\mu^2} - 1)}{1-4\mu^2} + \frac{3}{\mu} (2 \operatorname{cosech}^{-1} \mu - \operatorname{cosech}^{-1} 2\mu)$ $+ \frac{8(10\mu^2 - 1)}{3(1-4\mu^2)^{3/2}} \log_6 \frac{1 + \sqrt{1-4\mu^2}}{2(1-2\mu^2 + \sqrt{(1-4\mu^2)(1-\mu^2)})}$ $+ \frac{8}{3\sqrt{1-4\mu^2}} \operatorname{cosech}^{-1} \frac{1+4\mu^2}{4\mu}$
$\frac{1}{2}$	-1.45	4.94	11.28
$\frac{1}{2} < \mu < 1$	$\frac{1}{\sqrt{4\mu^2 - 1}} (\operatorname{cosech}^{-1} \frac{1}{2\mu} - \operatorname{cosech}^{-1} \frac{1-2\mu^2}{\mu})$ $- \frac{1}{\sqrt{1-\mu^2}} \log_6 (1 + \sqrt{1-\mu^2})$	$\frac{8}{3\sqrt{1-\mu^2}} \log_6 (1 + \sqrt{1-\mu^2}) - \frac{1-2\sqrt{1-\mu^2}}{1-4\mu^2}$ $+ \frac{4(11\mu^2 - 2)}{3(4\mu^2 - 1)^{3/2}} (\operatorname{cosech}^{-1} \frac{1-2\mu^2}{\mu} - \operatorname{cosech}^{-1} \frac{1}{2\mu})$	$\frac{8}{3\sqrt{1-\mu^2}} \log_6 (1 + \sqrt{1-\mu^2}) + \frac{4(2\sqrt{1-\mu^2} - 1)}{1-4\mu^2}$ $- \frac{3\pi}{2\mu} + \frac{8(10\mu^2 - 1)}{3(4\mu^2 - 1)^{3/2}} (\operatorname{cosech}^{-1} \frac{1-2\mu^2}{\mu} - \operatorname{cosech}^{-1} \frac{1}{2\mu})$ $+ \frac{6}{\mu} \operatorname{cosech}^{-1} \mu$
1	-2.21	7.84	8.96
$\mu > 1$	$- \frac{1}{\sqrt{\mu^2 - 1}} \operatorname{cosech}^{-1} \frac{1}{\mu} - \frac{1}{\sqrt{4\mu^2 - 1}} \operatorname{cosech}^{-1} \frac{1}{2\mu}$	$\frac{8}{3\sqrt{\mu^2 - 1}} \operatorname{cosech}^{-1} \frac{1}{\mu} + \frac{1}{4\mu^2 - 1}$ $+ \frac{4(11\mu^2 - 2)}{3(4\mu^2 - 1)^{3/2}} \operatorname{cosech}^{-1} \frac{1}{2\mu}$	$\frac{8}{3\sqrt{\mu^2 - 1}} \operatorname{cosech}^{-1} \frac{1}{\mu} + \frac{4}{4\mu^2 - 1} - \frac{3\pi}{2\mu}$ $+ \frac{8(10\mu^2 - 1)}{3(4\mu^2 - 1)^{3/2}} \operatorname{cosech}^{-1} \frac{1}{2\mu}$



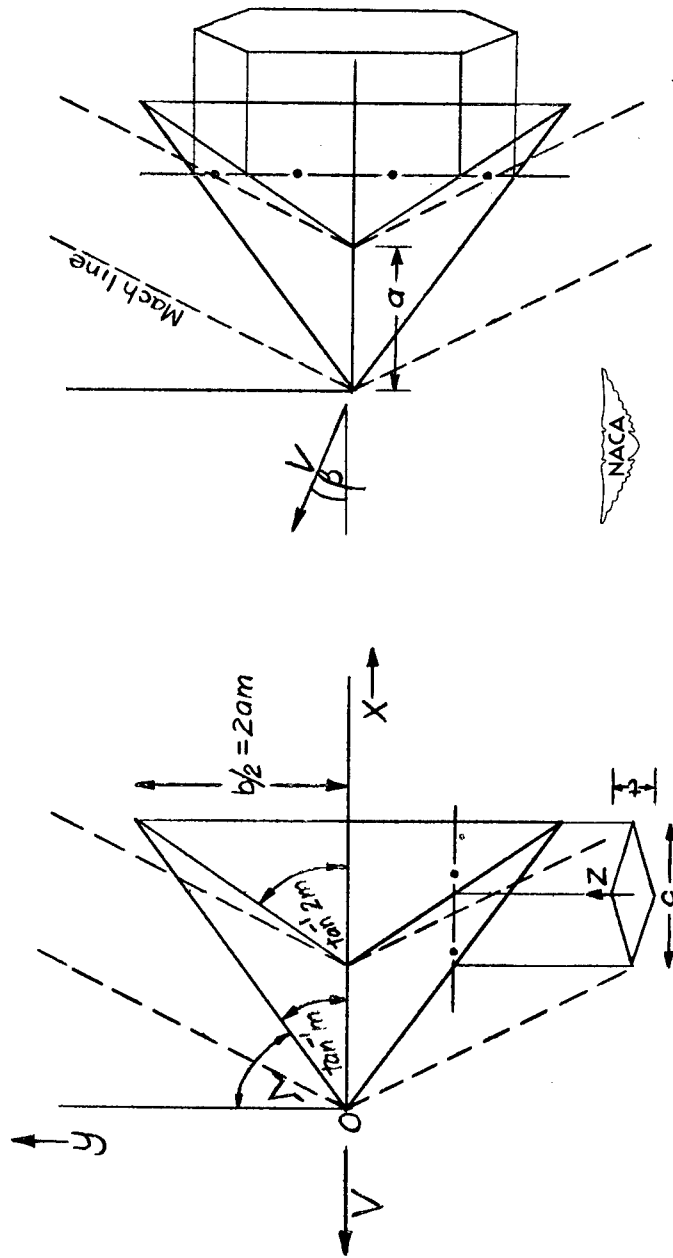

(a) Zero sideslip.

(b) Small sideslip.

Figure 1.- Wing plan form and profile, system of axes, and symbols used in analysis.

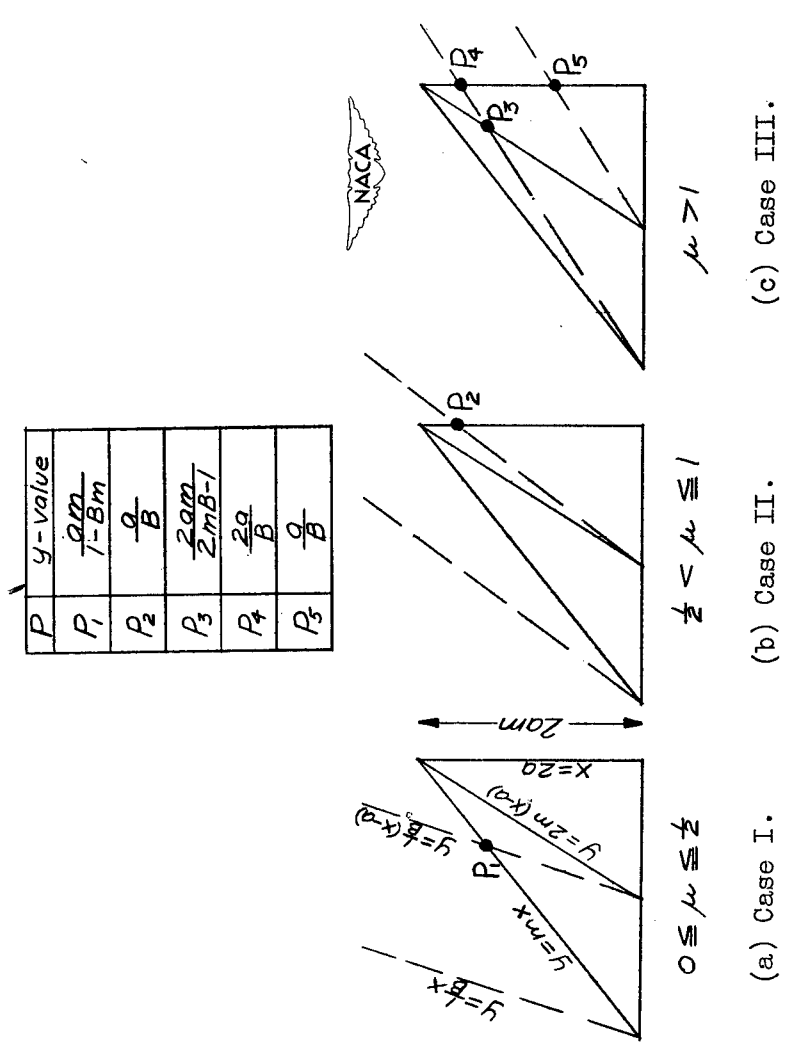

Figure 2.- Information pertinent to integration limits for equations presented in appendixes.

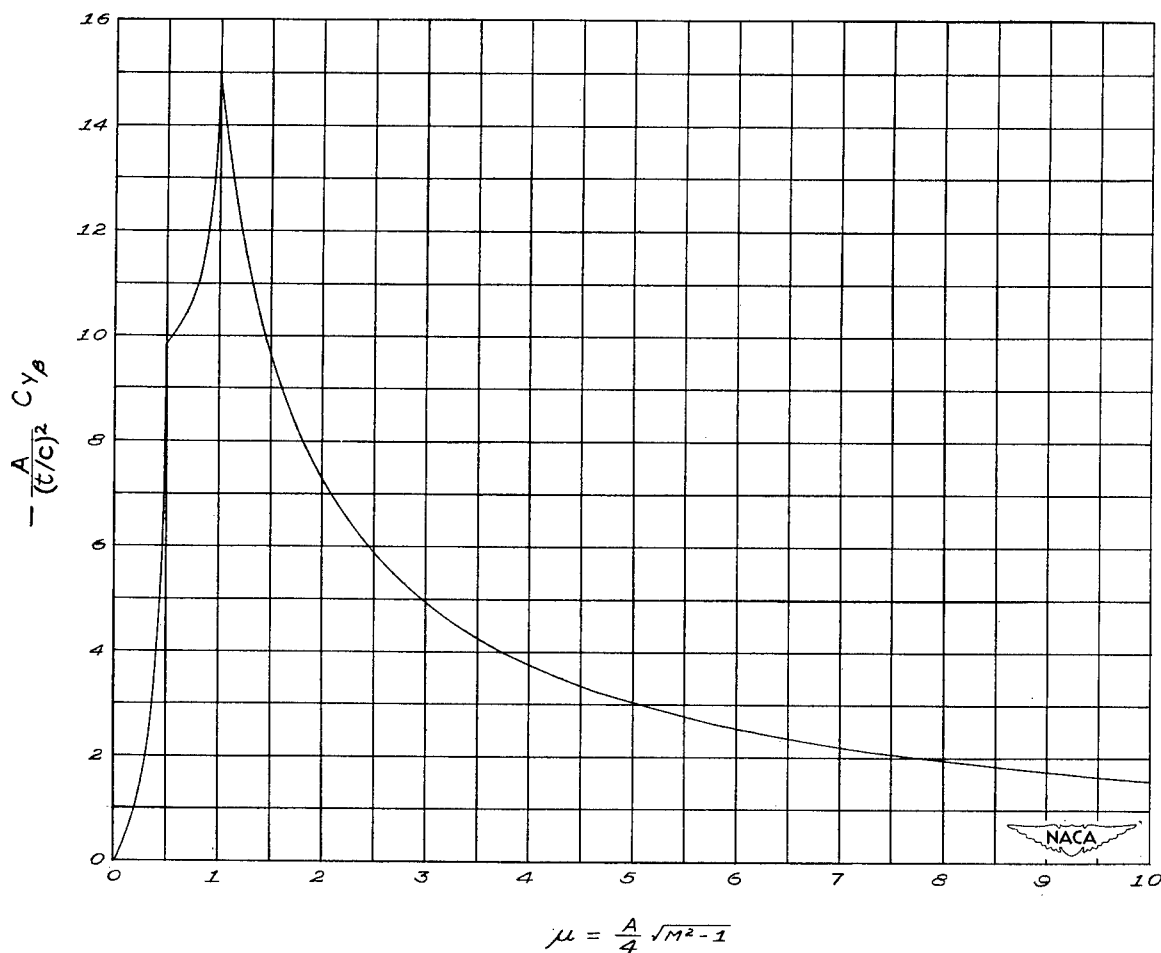

Figure 3.- Generalized curve presenting the variation of lateral-force derivative with a parameter relating aspect ratio and Mach number.

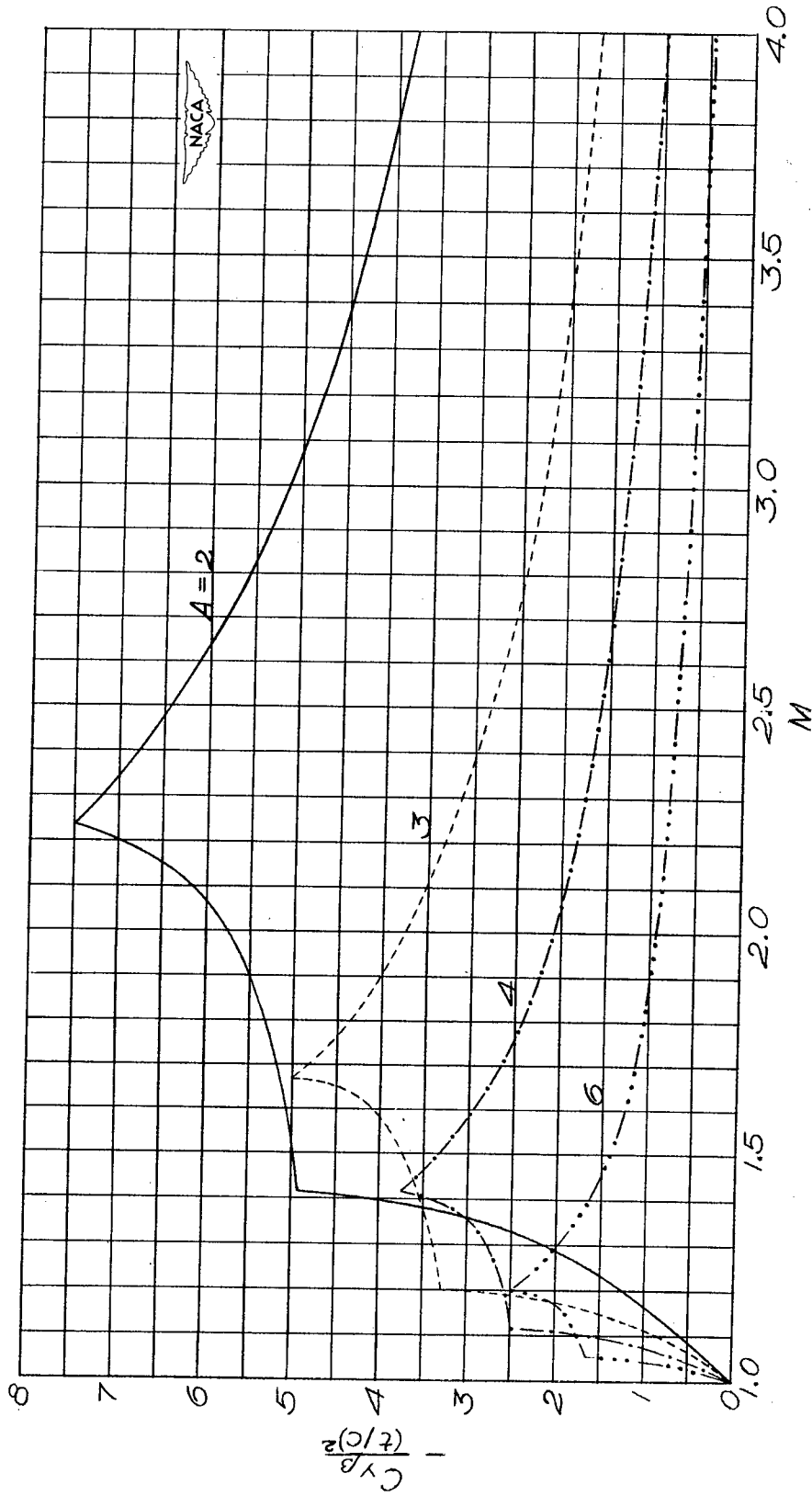
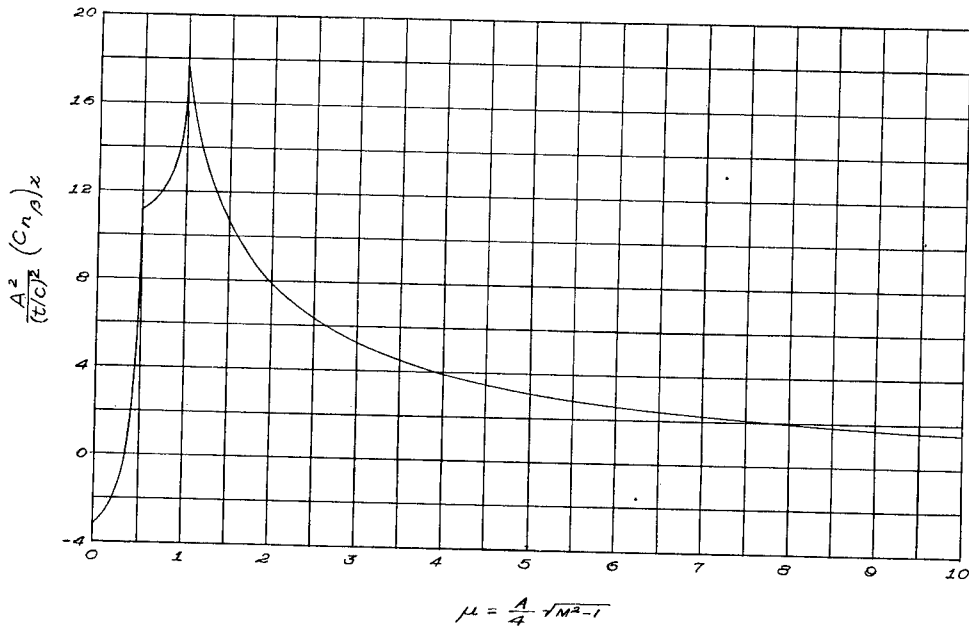
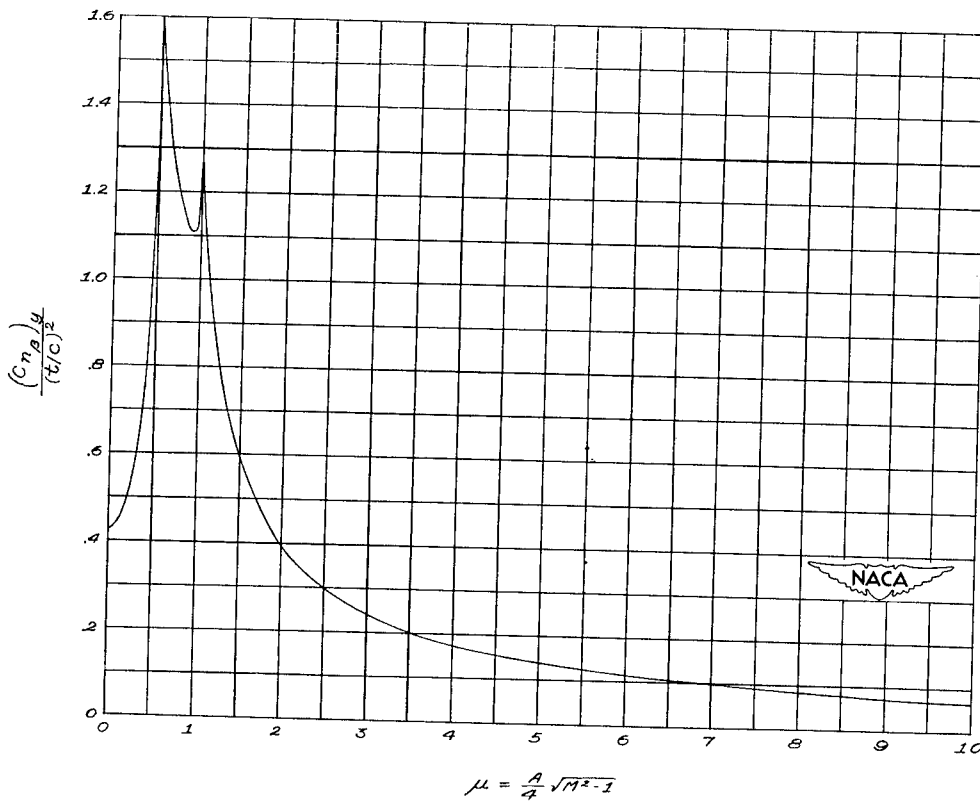

Figure 4.- Variation of lateral-force derivative with Mach number for various aspect ratios.



(a) Component involving x moment arms.



(b) Component involving y moment arms.

Figure 5.- Generalized curves presenting variation of yawing-moment derivative with a parameter relating aspect ratio and Mach number.

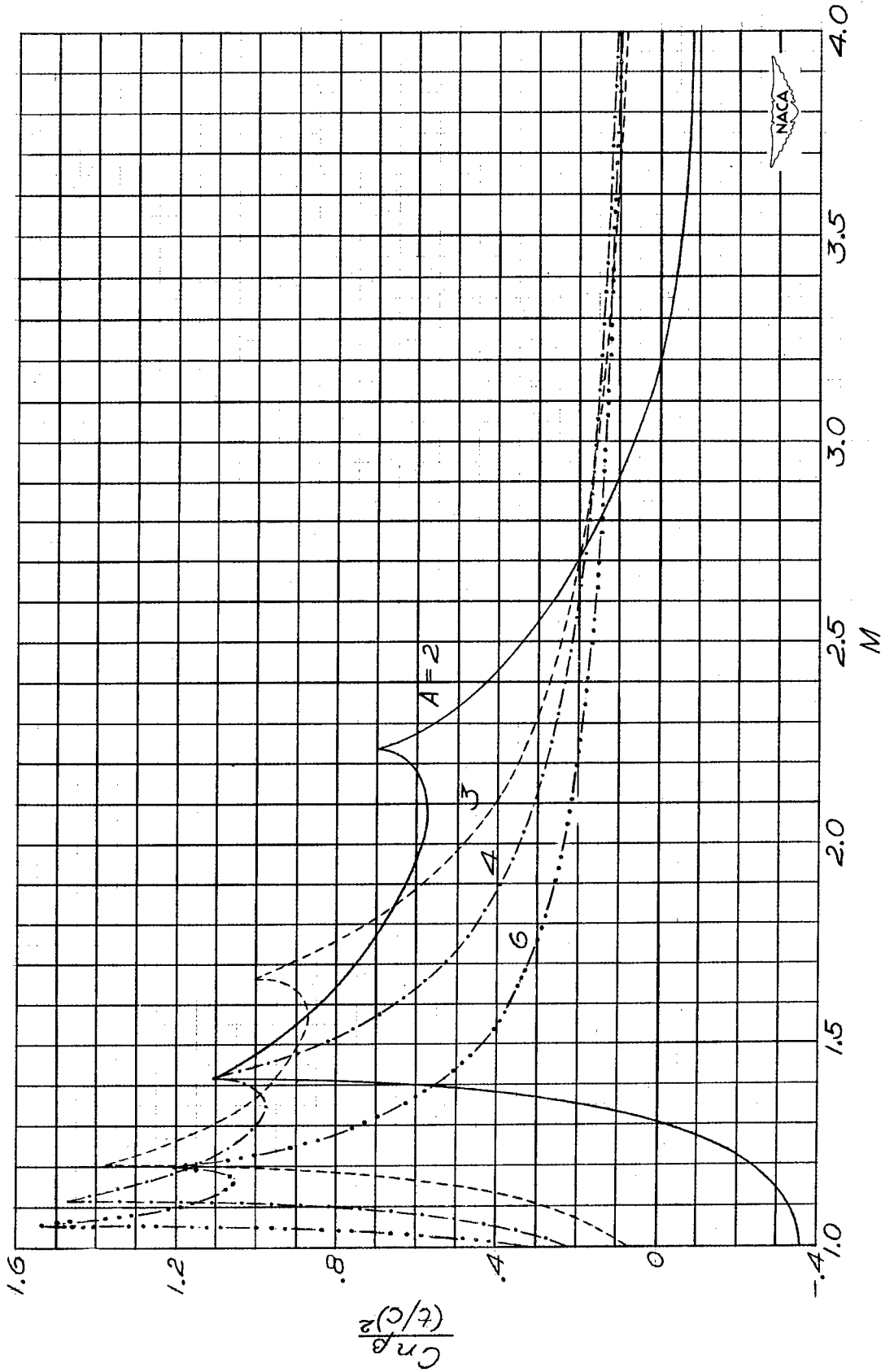

Figure 6.- Variation of yawing-moment derivative with Mach number for various aspect ratios.