

# NATIONAL ADVISORY COMMITTEE FOR AERONAUTICS

TECHNICAL NOTE

No. 1601

CHARACTERISTICS OF THIN TRIANGULAR WINGS WITH CONSTANT-CHORD  
FULL-SPAN CONTROL SURFACES AT SUPERSONIC SPEEDS

By Warren A. Tucker

Langley Aeronautical Laboratory  
Langley Field, Va.

**DISTRIBUTION STATEMENT A**  
Approved for Public Release  
Distribution Unlimited



Washington

July 1948

Reproduced From  
Best Available Copy

20000807 136

**DEC QUALITY INSPECTED 4**

AQM 00-11-3616

NATIONAL ADVISORY COMMITTEE FOR AERONAUTICS

---

TECHNICAL NOTE NO. 1601

---

CHARACTERISTICS OF THIN TRIANGULAR WINGS WITH CONSTANT-CHORD  
FULL-SPAN CONTROL SURFACES AT SUPERSONIC SPEEDS

By Warren A. Tucker

SUMMARY

A theoretical analysis was made of the characteristics of constant-chord full-span control surfaces on thin triangular wings at supersonic speeds by use of methods based on the linearized equation for supersonic flow. Expressions were found for the lift effectiveness, pitching-moment coefficient, hinge-moment coefficient due to control deflection, and hinge-moment coefficient due to angle of attack. These expressions were given as functions of the ratio of flap chord to wing chord and the ratio of the tangent of the wing-semiapex angle to the tangent of the Mach angle.

High values were found for the lift effectiveness, defined as the ratio of the lift coefficient produced by a unit flap deflection to the lift coefficient produced by a unit angle of attack of the wing. For certain combinations of flap size, wing-apex angle, and Mach number, the lift produced by a unit flap deflection was actually greater than the lift resulting from a unit angle of attack of the entire wing. These high values of lift effectiveness were the result of the low lift-curve slope of the wing rather than of any remarkable lift-producing capability on the part of the flap.

When the ratio of lift effectiveness to hinge-moment coefficient due to control deflection was compared with the corresponding ratio for a two-dimensional wing-flap combination having the same ratio of flap area to wing area, the present arrangement was slightly inferior to the two-dimensional case when the Mach lines were behind the leading edge. As the Mach lines moved ahead of the leading edge, the efficiency of the present arrangement reached and exceeded that of the two-dimensional combination.

INTRODUCTION

A variety of control-surface arrangements has been suggested for use on triangular wings at supersonic speeds. Some of the more obvious are the triangular-tip flap (reference 1), the constant-percent-chord flap, and the constant-chord flap. Of these various control-surface types, perhaps the simplest is the familiar constant-chord full-span trailing-edge flap.

The characteristics of this type of control surface are analyzed in the present paper by use of methods based on the linearized equation for supersonic flow. Simple expressions are obtained for the lift effectiveness, pitching-moment coefficient, hinge-moment coefficient due to control deflection, and hinge-moment coefficient due to angle of attack.

The results, having been found by methods based on the linearized equation, are valid only for small control-surface deflections and angles of attack.

### SYMBOLS

$b$  maximum wing span

$c$  wing root chord

$c_l$  wing local chord

$\bar{c}$  wing mean aerodynamic chord  $\left( \frac{2}{\pi} \int_0^{b/2} c_l^2 dy = \frac{2}{3}c \right)$

$c_f$  flap chord

$\bar{c}_f$  flap root-mean-square chord  $\left( \sqrt{c_f^2 - \frac{2}{3} \frac{c_f^3}{c}} \right)$

$C_L$  lift coefficient  $\left( \frac{\text{Lift}}{qS} \right)$

$C_m$  pitching-moment coefficient about wing aerodynamic center  $\left( \frac{\text{Pitching moment}}{qS\bar{c}} \right)$

$C_h$  hinge-moment coefficient  $\left( \frac{H}{qb\bar{c}_f^2} \right)$

$C_p$  lifting pressure coefficient  $\left( \frac{P}{q} \right)$

$E\left(\sqrt{1-m^2}\right)$  complete elliptic integral of second kind with modulus  $\sqrt{1-m^2}$

$H$  flap hinge moment

$M$  free-stream Mach number

$$m \equiv \frac{\tan \epsilon}{\tan \mu}$$

P lifting pressure on flap

q free-stream dynamic pressure  $\left(\frac{\rho V^2}{2}\right)$

S wing area  $\left(\frac{bc}{2}\right)$

$S_f$  flap area

V free-stream velocity

x,y Cartesian coordinates parallel and normal, respectively, to free-stream direction

$x_{cp}$  distance behind wing apex of center of pressure of lift resulting from flap deflection

$\alpha$  angle of attack

$\alpha_\delta$  lift effectiveness  $\left(\frac{C_{L_\delta}}{C_{L_\alpha}}\right)$

$$\beta \equiv \sqrt{M^2 - 1}$$

$\delta$  angle of flap deflection

$\epsilon$  wing-semiapex angle

$\mu$  Mach angle  $\left(\tan^{-1} \frac{1}{\beta}\right)$

$$v \equiv \frac{\beta y}{x} \equiv \frac{y/x}{\tan \mu}$$

$\rho$  free-stream density

$\phi$  disturbance-velocity potential

$\phi_x$  disturbance velocity in x-direction

## Subscripts:

- $\alpha$  partial derivative of coefficient with respect to  $\alpha$   
 (example:  $C_{L\alpha} \equiv \frac{\partial C_L}{\partial \alpha}$ )
- $\delta$  partial derivative of coefficient with respect to  $\delta$  (except when used in  $\alpha_\delta$ )
- $C_L$  partial derivative of coefficient with respect to  $C_L$
- $\infty$  two-dimensional case

All angles are in radians, unless otherwise specified.

## ANALYSIS

## Lift Effectiveness

The control-surface configuration under investigation is shown in figure 1. In calculating the lift caused by a flap deflection  $\delta$ , the angle of attack  $\alpha$  may be assumed to be zero. The deflected flap may then conveniently be regarded as a trapezoidal wing at an angle of attack equal to  $\delta$ . Two regions of flow are distinguished in determining the lift. (See fig. 2.) In region  $S_I$ , the pressure is constant and equal to the pressure on a wing of infinite span. In each of the regions  $S_{II}$  the effect of the finite tip must be considered.

The pressure in regions  $S_{II}$  may be calculated by a powerful method developed by Evvard (reference 2). Figure 3 shows the notation used in reference 2. The equations of the leading edge and the tip are defined in reference 2 in terms of an oblique  $u,v$ -coordinate system whose axes are the Mach lines originating at the tip. For the present case, the values of  $k_1$  and  $k_2$  (fig. 3) become

$$\left. \begin{aligned} k_1 &= 1 \\ k_2 &= \frac{1 + \beta \tan \epsilon}{1 - \beta \tan \epsilon} \end{aligned} \right\} \quad (1)$$

The velocity potential at a point  $(x,y)$  on one surface is given by equation (20) of reference 2 for a wing having a wedge-shaped section. As pointed out in reference 2, only the second term (which is independent of the airfoil section) contributes to the lift due to angle of attack. The potential at a point  $(x,y)$  on one side of the surface for the present case is thus given by

$$\phi = \frac{v\delta}{\pi\beta} \left\{ \frac{(k_1 + k_2)(x + \beta y) [(k_2 - 1)x - (k_2 + 1)\beta y]}{k_2^2} + \frac{(1 + k_1)x + (1 - k_1)\beta y}{\sqrt{k_1}} \tan^{-1} \sqrt{\frac{k_1 [(k_2 - 1)x - (k_2 + 1)\beta y]}{(k_1 + k_2)(x + \beta y)}} \right\} \quad (2)$$

where  $k_1$  and  $k_2$  have the values noted in equation (1).

In order to obtain an expression for the pressure, the disturbance-velocity component  $\phi_x$  on which the pressure is dependent is obtained by differentiating equation (2) with respect to  $x$ . The differentiation yields

$$\phi_x = \frac{2v\delta}{\pi\beta} \left( \frac{\beta \tan \epsilon}{1 + \beta \tan \epsilon} \sqrt{\frac{1 + \frac{\beta y}{x}}{\beta \tan \epsilon - \frac{\beta y}{x}}} + \tan^{-1} \sqrt{\frac{\beta \tan \epsilon - \frac{\beta y}{x}}{1 + \frac{\beta y}{x}}} \right)$$

For convenience write

$$m = \beta \tan \epsilon$$

where  $0 \leq m \leq 1$  and

$$v = \beta \frac{y}{x} \quad (3)$$

where  $-1 \leq v \leq m$ . When  $m = 1$ , the Mach line lies along the wing tip; when  $m = 0$ , the tip is rectangular (for Mach numbers greater than unity). The value  $v = m$  defines the wing tip; the value  $v = -1$  defines the tip Mach line lying on the flap. The equation for  $\phi_x$  then becomes

$$\phi_x = \frac{2v\delta}{\pi\beta} \left( \frac{m}{1 + m} \sqrt{\frac{1 + v}{m - v}} + \tan^{-1} \sqrt{\frac{m - v}{1 + v}} \right) \quad (4)$$

By defining a pressure coefficient as

$$C_p = \frac{P}{q}$$

where  $P$  is the lifting pressure on the flap,

$$C_p = \frac{4}{v} \phi_x$$

or

$$C_p = \frac{8\delta}{\pi\beta} \left( \frac{m}{1+m} \sqrt{\frac{1+v}{m-v}} + \tan^{-1} \sqrt{\frac{m-v}{1+v}} \right) \quad (5)$$

Values of  $C_p\beta/\delta$  are shown in figure 4 for several values of  $m$ . When  $m = 0$ , equation (5) correctly gives the pressure distribution over the tip of a rectangular wing as found by other investigators.

With the pressure known at all points, determination of the lift coefficient per unit flap deflection is now possible. The derivation is carried out for the case shown in figure 2, where the Mach lines do not intersect each other. As is pointed out subsequently, the result obtained is also valid when the Mach lines intersect, so long as the Mach line from one tip does not cross the opposite tip. The lift on one tip is

$$L_{II} = q \int_{S_{II}} C_p dS = \frac{c_f^2}{2\beta} q \int_{-1}^m C_p dv$$

or

$$\frac{L_{II}}{q\delta} = \frac{4c_f^2}{\pi\beta^2} \left( \frac{m}{1+m} \int_{-1}^m \sqrt{\frac{1+v}{m-v}} dv + \int_{-1}^m \tan^{-1} \sqrt{\frac{m-v}{1+v}} dv \right)$$

The integrals may be evaluated with the aid of equation (111), (161), and (169) of reference 3 and the result is

$$\frac{L_{II}}{q\delta} = \frac{c_f^2}{\beta^2}(3m + 1)$$

The pressure coefficient in the region  $S_I$  has the two-dimensional value  $4\delta/\beta$ , and the area  $S_I$  can be shown to be

$$S_I = bc_f - \frac{c_f^2}{\beta}(1 + 2m)$$

so that

$$\frac{L_I}{q\delta} = \frac{4}{\beta} \left[ bc_f - \frac{c_f^2}{\beta}(1 + 2m) \right]$$

If the lift coefficient is based on the total wing area  $bc/2$ , then the lift coefficient per unit flap deflection is

$$C_{L\delta} = \frac{2 \left( \frac{L_I}{q\delta} + 2 \frac{L_{II}}{q\delta} \right)}{bc}$$

Substituting the expressions for  $L_I/q\delta$  and  $L_{II}/q\delta$  results in

$$C_{L\delta} = \frac{4}{\beta} \left[ 2 \frac{c_f}{c} - \left( \frac{1+m}{2m} \right) \left( \frac{c_f}{c} \right)^2 \right] \quad (6a)$$

The case  $\frac{c_f}{c} = 1$  represents a complete triangular wing, and when  $m = 1$  equation (6a) correctly gives the lift-curve slope as found by other investigators (references 4 and 5). However, when  $m$  is different from 1, equation (6a) does not give the values found in references 4 and 5. An examination of the range of applicability is thus in order.

Equation (2) is noted to be valid only for  $0 < m < 1$  (Mach lines ahead of the leading edge), so that equation (6a) should not be expected to hold for  $m > 1$ . A further restriction is necessary for  $m < 1$ .

Equation (6a) was derived for the case where the Mach line from one tip does not meet the Mach line from the other tip. The case where the Mach lines intersect has been examined, and equation (6a) has been found to apply also to this case so long as the Mach line from one tip does not cross the opposite tip. This situation is similar to that arising in the case of the lift of a rectangular wing. (See reference 6, for example.) For the present configuration, the limiting condition corre-

sponds to  $\frac{c_f}{c} \leq \frac{2m}{1+m}$ . The range of applicability for  $m < 1$  is shown in figure 5. The same range is also applicable to the results for pitching moment and hinge moment due to control deflection to be found subsequently. The restriction will be found unnecessary in the case of hinge moment due to angle of attack.

For the cases when  $m > 1$  (Mach lines behind the leading edge), use may be made of an analysis in reference 5 which shows that the lift coefficient and center of pressure are the same as if the flap were subject to the uniform lift distribution of an infinite span airfoil. (Note the similarity of this case to that of a triangular wing with the Mach lines behind the leading edge.) For this case equation (6a) applies if  $m$  is set equal to unity. The quantity in brackets then becomes the flap area ratio  $S_f/S$ .

Now that the range in which the results are applicable is known, the complete equations may be written

$$C_{L\delta} = \frac{4}{\beta} \left[ 2 \frac{c_f}{c} - \left( \frac{1+m}{2m} \right) \left( \frac{c_f}{c} \right)^2 \right] \quad (6b)$$

where  $\frac{c_f/c}{2 - \frac{c_f}{c}} \leq m \leq 1$  and

$$C_{L\delta} = \frac{4}{\beta} \left[ 2 \frac{c_f}{c} - \left( \frac{c_f}{c} \right)^2 \right] = \frac{4}{\beta} \frac{S_f}{S} \quad (6c)$$

where  $m \geq 1$ .

The nondimensional quantity  $\alpha_\delta$  is customarily used to express the lift effectiveness of a control surface, which may be regarded as the ratio of the lift coefficient produced by a unit flap deflection to the lift coefficient produced by a unit angle of attack of the whole wing.

In reference 4 an expression has been obtained for the lift-curve slope of a triangular wing for  $m \leq 1$ . Rewriting the expression of reference 4 in the notation of the present paper gives

$$C_{L\alpha} = \frac{1}{\beta} \frac{2\pi m}{E(\sqrt{1-m^2})} \quad (7a)$$

where  $E(\sqrt{1-m^2})$  is the complete elliptic integral of the second kind with modulus  $\sqrt{1-m^2}$ . For the case  $m \geq 1$ , the value of  $C_{L\alpha}$  has been found in reference 7 and is simply

$$C_{L\alpha} = \frac{4}{\beta} \quad (7b)$$

The lift effectiveness is

$$\alpha_\delta = \frac{C_{L\delta}}{C_{L\alpha}}$$

or

$$\alpha_\delta = \frac{2E(\sqrt{1-m^2})}{\pi m} \left[ 2 \frac{c_f}{c} - \left( \frac{1+m}{2m} \right) \left( \frac{c_f}{c} \right)^2 \right] \quad (8a)$$

where  $\frac{c_f/c}{2 - \frac{c_f}{c}} \leq m \leq 1$  and

$$\alpha_\delta = 2 \frac{c_f}{c} - \left( \frac{c_f}{c} \right)^2 = \frac{3_f}{3} \quad (8b)$$

where  $m \geq 1$ . Values of  $\alpha_\delta$  are given in figure 6. At  $\frac{c_f}{c} = 1$ ,  $\alpha_\delta = 1$  for any value of  $m$  because the control surface now comprises the entire wing. The very high values of  $\alpha_\delta$  are due more to the low lift-curve slope of the wing rather than to any particular efficacy on the part of

the flap. For certain combinations of  $c_f/c$  and  $m$ ,  $\alpha_\delta$  is greater than unity; this fact indicates that a unit flap deflection will produce more lift than a unit angle of attack of the whole wing.

A standard of comparison for control-surface arrangements is the two-dimensional wing-flap combination. For this case, the lift effectiveness is merely

$$\alpha_{\delta_\infty} = \left(\frac{c_f}{c}\right)_\infty = \left(\frac{S_f}{S}\right)_\infty \quad (9)$$

When the Mach lines are behind the leading edge ( $m \geq 1$ ),

$$\frac{\alpha_\delta}{\alpha_{\delta_\infty}} = \frac{S_f/S}{(S_f/S)_\infty}$$

so that for equal flap area ratios  $\frac{\alpha_\delta}{\alpha_{\delta_\infty}} = 1$ . A more complete comparison

with the two-dimensional case is made in the section entitled "Discussion and Concluding Remarks."

#### Pitching Moment

An important parameter in stability and control calculations is the pitching moment about the wing aerodynamic center resulting from a given lift on the flap. If the pitching-moment coefficient is based on the total wing area and the wing mean aerodynamic chord  $\left(\frac{2}{3}c\right)$  so that

$$C_m = \frac{\text{Pitching moment}}{qS\bar{c}} = \frac{3}{2} \frac{\text{Pitching moment}}{qSc}$$

and if the wing aerodynamic center is noted to be at  $\frac{2}{3}c$  behind the wing apex, then the pitching moment resulting from lift on the flap can be expressed in coefficient form as

$$C_{mC_L} = \frac{\partial}{\partial C_L} \left[ \frac{3}{2} \frac{C_L q S \left( x_{cp} - \frac{2}{3}c \right)}{q S c} \right] = \frac{3}{2} \left( \frac{x_{cp}}{c} - \frac{2}{3} \right)$$

where  $x_{cp}/c$  is the distance (expressed as a fraction of the root chord) behind the wing apex of the center of pressure of the lift resulting from flap deflection. This distance is found to be

$$\frac{x_{cp}}{c} = \frac{12m - (3 + 9m)\frac{c_f}{c} + (1 + 3m)\left(\frac{c_f}{c}\right)^2}{12m - (3 + 3m)\frac{c_f}{c}} \quad (10a)$$

where  $\frac{c_f/c}{2 - \frac{c_f}{c}} \leq m \leq 1$  and

$$\frac{x_{cp}}{c} = \frac{6 - 6\frac{c_f}{c} + 2\left(\frac{c_f}{c}\right)^2}{6 - 3\frac{c_f}{c}} \quad (10b)$$

where  $m \geq 1$  so that

$$C_{mC_L} = - \frac{4m - (1 + 7m)\frac{c_f}{c} + (1 + 3m)\left(\frac{c_f}{c}\right)^2}{8m - (2 + 2m)\frac{c_f}{c}} \quad (11a)$$

where  $\frac{c_f/c}{2 - \frac{c_f}{c}} \leq m \leq 1$  and

$$C_{mC_L} = - \frac{1 - 2\frac{c_f}{c} + \left(\frac{c_f}{c}\right)^2}{2 - \frac{c_f}{c}} \quad (11b)$$

where  $m \geq 1$ . Values of  $-C_{mC_L}$  are given in figure 7.

## Hinge Moment Due to Control Deflection

The hinge-moment coefficient caused by a unit flap deflection  $C_{h\delta}$  can be found in the same manner as  $C_{mC_L}$  if moments are taken about the hinge line rather than the aerodynamic center. If the hinge-moment coefficient is based on the maximum flap span  $b$  and the square of the root-mean-square flap chord  $\bar{c}_F$  so that

$$C_h = \frac{H}{qb\bar{c}_F^2} \quad (12)$$

where

$$\bar{c}_F^2 = c_F^2 - \frac{2}{3} \frac{c_F^3}{c}$$

then

$$C_{h\delta} = -\frac{2}{\beta} \left( \frac{3 - \frac{1}{m} \frac{c_F}{c}}{3 - 2 \frac{c_F}{c}} \right) \quad (13a)$$

where  $\frac{c_F/c}{2 - \frac{c_F}{c}} \leq m \leq 1$  and

$$C_{h\delta} = -\frac{2}{\beta} \left( \frac{3 - \frac{c_F}{c}}{3 - 2 \frac{c_F}{c}} \right) \quad (13b)$$

where  $m \geq 1$ . Values of  $-C_{h\delta}\beta/2$  are given in figure 8. The values of  $-C_{h\delta}\beta/2$  for  $\frac{c_F}{c} = 1$  (shown by circles) are the values of  $-C_{h\alpha}\beta/2$  taken from the next section, since at  $\frac{c_F}{c} = 1$   $C_{h\delta}$  must necessarily equal  $C_{h\alpha}$ . The value of  $C_{h\delta}$  for the two-dimensional case is simply

$$C_{h\delta\infty} = -\frac{2}{\beta} \quad (14)$$

so that the values of  $-C_{h\delta}\beta/2$  in figure 8 are also the values of  $C_{h\delta}/C_{h\delta_\infty}$ .

#### Hinge Moment Due to Angle of Attack

An expression for the flap hinge moment resulting from a change in angle of attack of the wing  $C_{h\alpha}$  may be obtained even more simply than the expressions derived previously, since in this case the only knowledge required is that of the lift-curve slope of a triangular wing, which has been found by other investigators (references 4, 5, and 7).

The scheme employed is shown in figure 9. If the area of the whole wing is denoted by  $S$  and the wing area minus the flap area by  $S - S_f$ , then the flap hinge moment  $H$  can be written as

$$H = H_S - H_{S-S_f}$$

or

$$\frac{H}{q\alpha} = C_{I_\alpha} \left[ S \left( \frac{c}{3} - c_f \right) - S \left( \frac{c - c_f}{c} \right)^2 \left( \frac{c - c_f}{3} \right) \right]$$

If as before the flap hinge-moment coefficient is based on  $b\bar{c}_f^2$  so that

$$C_{h\alpha} = \frac{H/q\alpha}{b\bar{c}_f^2}$$

then

$$C_{h\alpha} = -C_{I_\alpha} \left( \frac{3 - \frac{c_f}{c}}{6 - 4\frac{c_f}{c}} \right)$$

Substituting the expressions for  $C_{I_\alpha}$  given by equations (7a) and (7b) gives

$$C_{h\alpha} = -\frac{2}{\beta} \frac{\pi m}{2E(\sqrt{1-m^2})} \left( \frac{3 - \frac{c_f}{c}}{3 - 2\frac{c_f}{c}} \right) \quad (15a)$$

where  $m \leq 1$  and

$$C_{h\alpha} = -\frac{2}{\beta} \left( \frac{3 - \frac{c_f}{c}}{3 - 2\frac{c_f}{c}} \right) \quad (15b)$$

where  $m \geq 1$ . Note that the expression for  $C_{h\alpha}$  for  $m \geq 1$  is identical to that obtained for  $C_{h\delta}$  for  $m \geq 1$  (equation (13b)). This identity should be true because when the Mach lines are behind the leading edge either the lift on a triangular wing or the lift on the trapezoid wing considered to represent the flap are the same as if the pressure on the wing were constant and had the two-dimensional value.

Values of  $-C_{h\alpha}\beta/2$  are presented in figure 10. The value of  $C_{h\alpha}$  for the two-dimensional wing-flap combination is

$$C_{h\alpha_{\infty}} = -\frac{2}{\beta} \quad (16)$$

so that figure 10 is also a plot of  $C_{h\alpha}/C_{h\alpha_{\infty}}$ .

#### DISCUSSION AND CONCLUDING REMARKS

Several quantities may be used to evaluate the efficiency of a control-surface system. One commonly used quantity is the ratio  $\alpha_{\delta}/C_{h\delta}$ , which is an indication of the lift resulting from the application of a given control force. By use of this ratio, the present control-surface arrangement can be compared with a two-dimensional wing-flap combination on the basis of equal ratios of flap area to total wing area. The comparison gives

$$\left( \frac{\alpha_\delta / C_{h\delta}}{\alpha_{\delta_\infty} / C_{h\delta_\infty}} \right) \frac{S_f}{S} = \left( \frac{S_f}{S} \right)^\infty = \frac{2E \left( \sqrt{1 - m^2} \right)^{\pi m}}{1 - \frac{1 - m}{2m} \left[ 1 - \frac{1 - m}{2m} \left( 2 - \frac{S_f}{S} - 2 \sqrt{1 - \frac{S_f}{S}} \right) \right]} \left[ \frac{3 - 2 \left( 1 - \sqrt{1 - \frac{S_f}{S}} \right)}{3 - \frac{1}{m} \left( 1 - \sqrt{1 - \frac{S_f}{S}} \right)} \right] \quad (17a)$$

where

$$\frac{1 - \sqrt{1 - \frac{S_f}{S}}}{1 + \sqrt{1 - \frac{S_f}{S}}} \leq m \leq 1$$

and

$$\left( \frac{\alpha_\delta / C_{h\delta}}{\alpha_{\delta_\infty} / C_{h\delta_\infty}} \right) \frac{S_f}{S} = \left( \frac{S_f}{S} \right)^\infty = \frac{3 - 2 \left( 1 - \sqrt{1 - \frac{S_f}{S}} \right)}{3 - \left( 1 - \sqrt{1 - \frac{S_f}{S}} \right)} \quad (17b)$$

where  $m \geq 1$ . Values from equations (17) are shown in figure 11. For the usual range of the ratio of flap area to wing area (less than 0.5, for example), the value of  $\alpha_\delta / C_{h\delta}$  for the present arrangement is never less than 0.9 of the value for the two-dimensional combination. As the Mach lines move ahead of the leading edge, the efficiency of the present arrangement increases

and soon exceeds that of the two-dimensional combination for a wide range of flap area ratios. A large part of this increase results from the dropping off of the lift-curve slope of the triangular wing.

In reference 1 the efficiency of a triangular-tip flap on a triangular wing with the Mach lines behind the leading edge was shown to be equal to that of a two-dimensional wing-flap combination having the same flap area ratio. So long as the Mach lines are behind the leading edge, then, the triangular-tip control surface appears to be superior to the constant-chord flap on the basis of  $\alpha_0/C_{h\delta}$  (although for flap area ratios less than about 0.5 the difference in efficiencies is not considerable). The results of an analysis of the triangular-tip flap with the Mach lines ahead of the leading edge are not yet available, so that a comparison of the constant-chord flap with this perhaps more interesting case cannot yet be made.

For certain combinations of  $c_f/c$  and  $m$ , the lift effectiveness  $\alpha_0$  is greater than unity. (See fig. 6.) These very high values are more the result of the low lift-curve slope of the wing for low values of  $m$  rather than of any remarkable lift-producing capability on the part of the flap.

Although the parameter  $m$  arises naturally in the analysis of triangular wings, expression of control-surface characteristics as direct functions of the Mach number  $M$  is often convenient, especially for design purposes. Figure 12 shows the variation of control-surface characteristics with Mach number for one particular configuration with  $\epsilon = 45^\circ$  and  $\frac{c_f}{c} = 0.2$ . Other such plots can be made from the equations presented in this paper or from the figures.

Langley Memorial Aeronautical Laboratory  
National Advisory Committee for Aeronautics  
Langley Field, Va., March 29, 1948

## REFERENCES

1. Tucker, Warren A.: Characteristics of Thin Triangular Wings with Triangular-Tip Control Surfaces at Supersonic Speeds with Mach Lines behind the Leading Edge. NACA TN No. 1600, 1948.
2. Evard, John C.: Distribution of Wave Drag and Lift in the Vicinity of Wing Tips at Supersonic Speeds. NACA TN No. 1382, 1947.
3. Peirce, B. O.: A Short Table of Integrals. Second ed., Ginn and Co., 1910.
4. Stewart, H. J.: The Lift of a Delta Wing at Supersonic Speeds. Quarterly Appl. Math., vol. IV, no. 3, Oct. 1946, pp. 246-254.
5. Brown, Clinton E.: Theoretical Lift and Drag of Thin Triangular Wings at Supersonic Speeds. NACA TN No. 1183, 1946.
6. Snow, R. M., and Bonney, E. A.: Aerodynamic Characteristics of Wings at Supersonic Speeds. Bumblebee Rep. No. 55, The Johns Hopkins Univ., Appl. Physics Lab., March 1947.
7. Puckett, Allen E.: Supersonic Wave Drag of Thin Airfoils. Jour. Aero. Sci., vol. 13, no. 9, Sept. 1946, pp. 475-484.

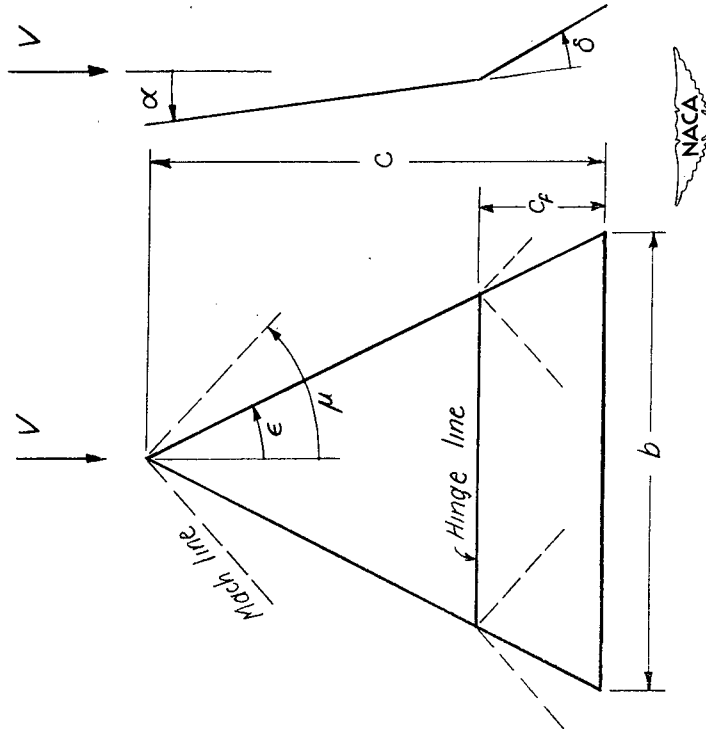

Figure 1.- Control-surface configuration.

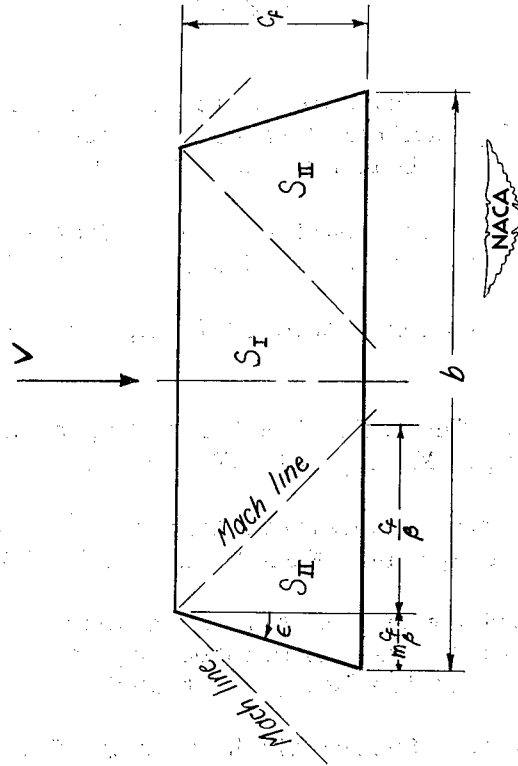

Figure 2.- The flap regarded as a trapezoidal wing.

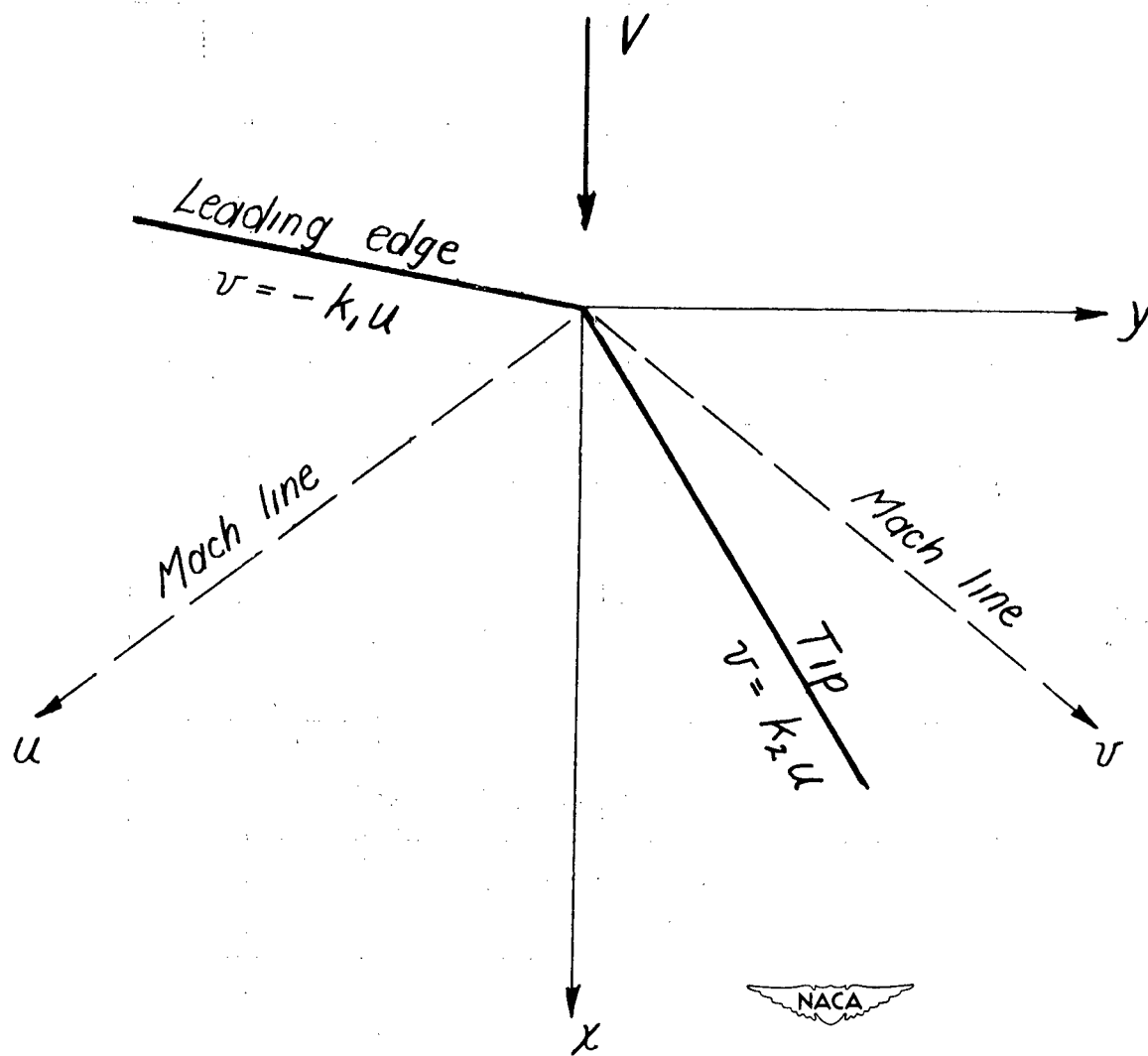

Figure 3.- Notation for the case considered in reference 2.

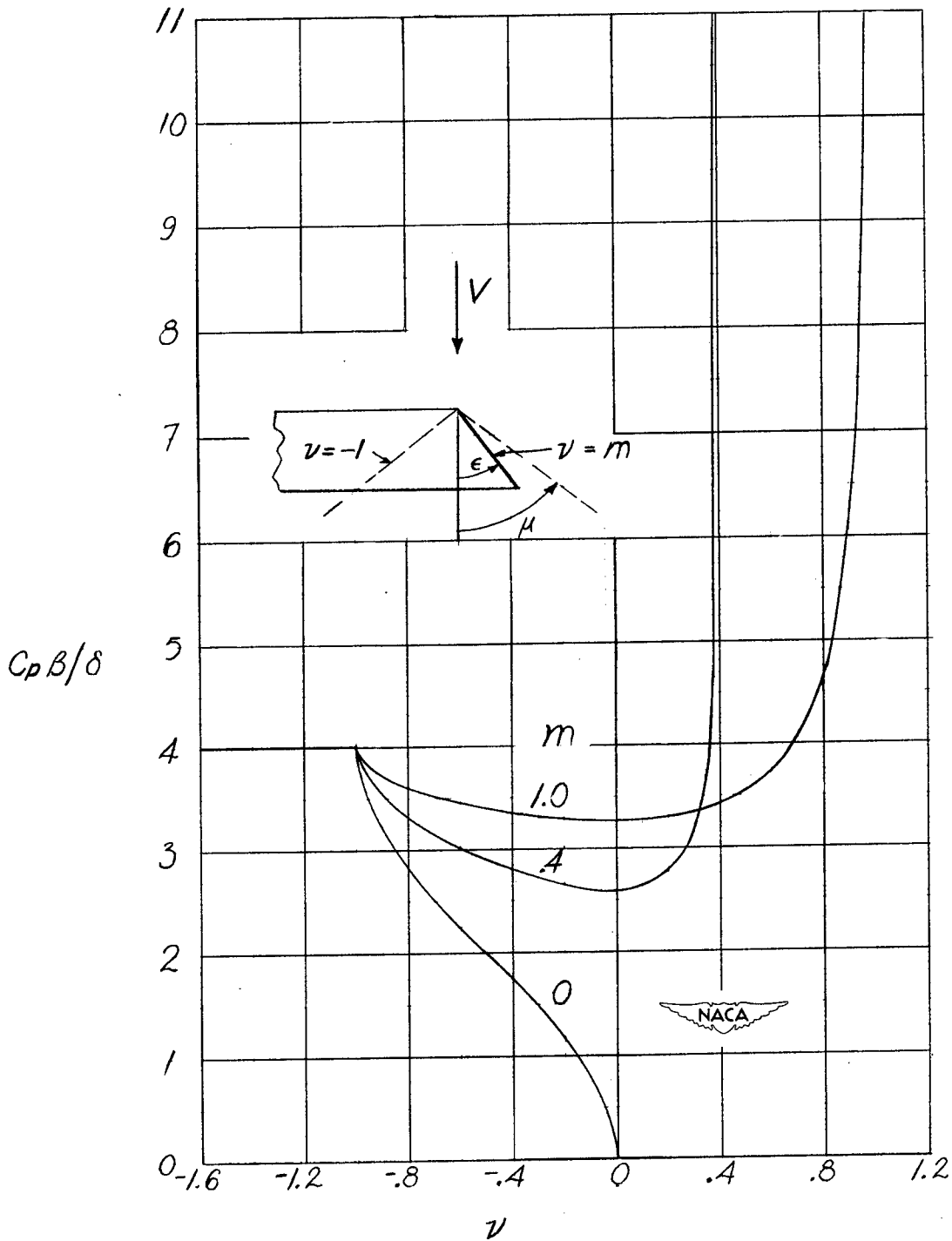

Figure 4.- Pressure distribution in the tip region of a trapezoid wing.

$$m = \frac{\tan \epsilon}{\tan \mu}$$

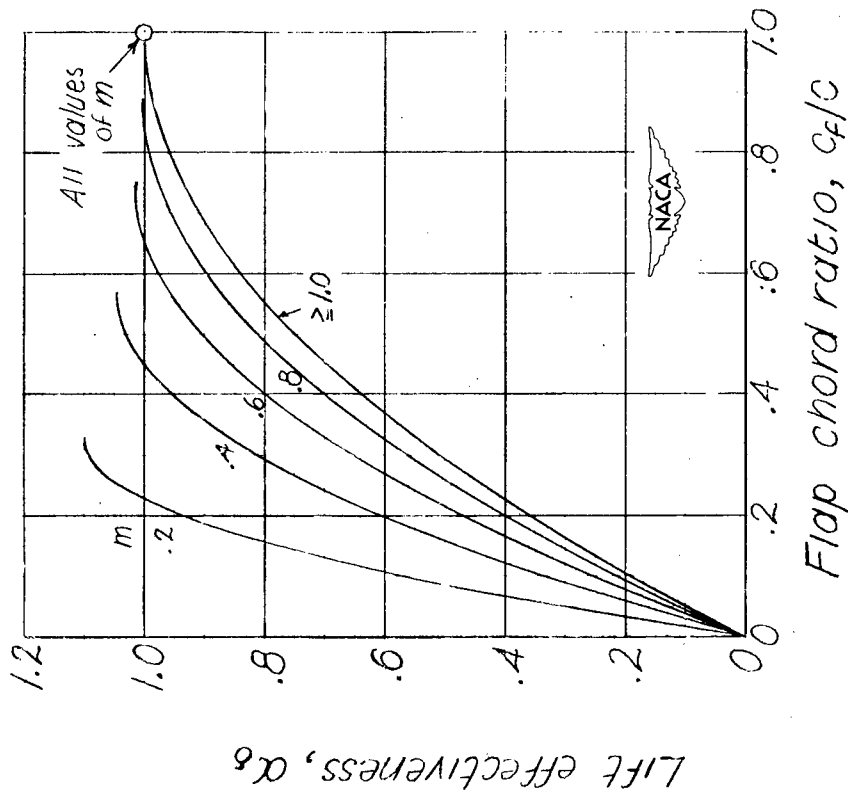

Figure 6.- Lift effectiveness of constant-chord full-span control surfaces on triangular wings.

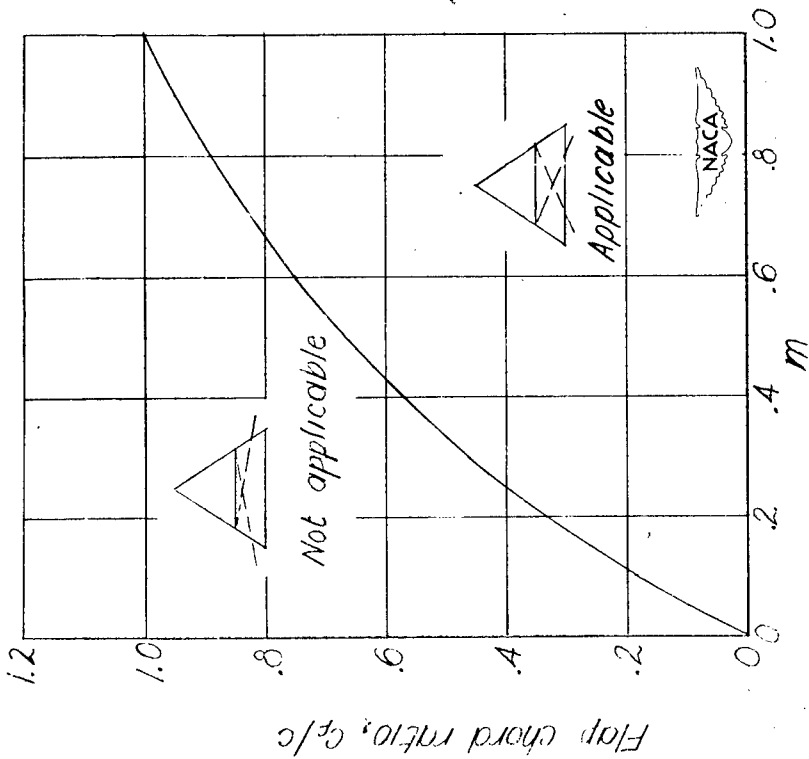
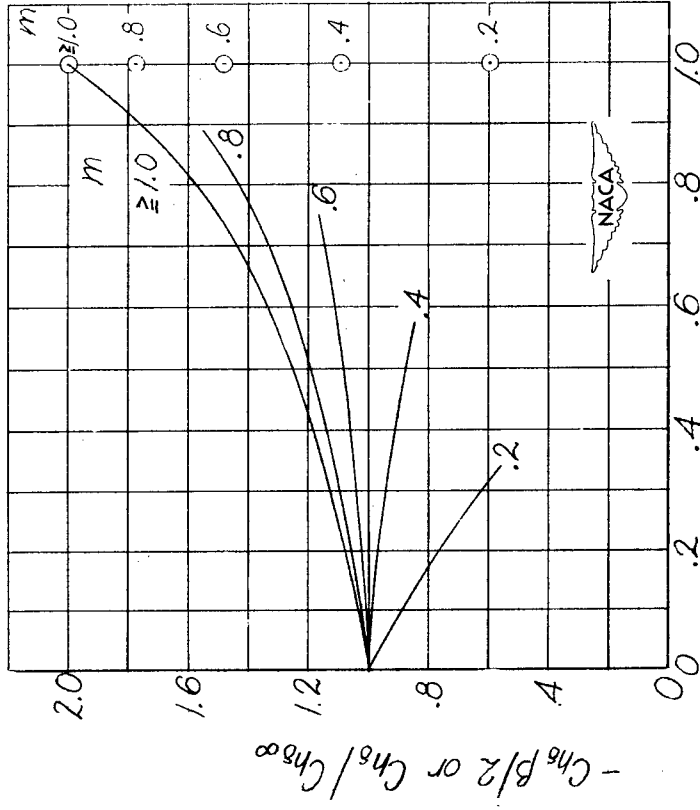
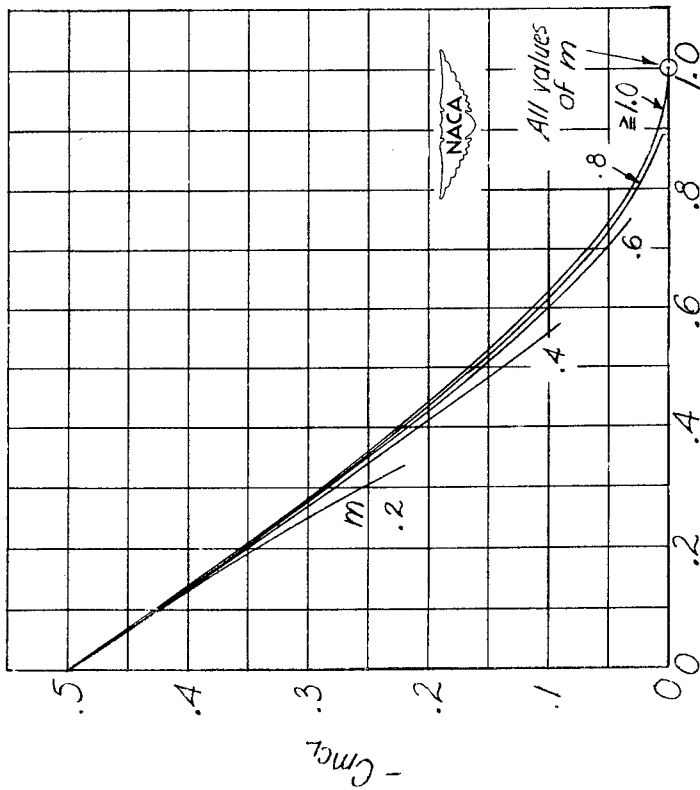

Figure 5.- Range of applicability of equations for lift, pitching moment, and hinge moment due to control deflection.



Flap chord ratio,  $q_f/c$

Figure 8.- Characteristics of hinge moment due to control deflection. Constant-chord full-span control surfaces on triangular wings.



Flap chord ratio,  $q_f/c$

Figure 7.- Pitching-moment characteristics of constant-chord full-span control surfaces on triangular wings.

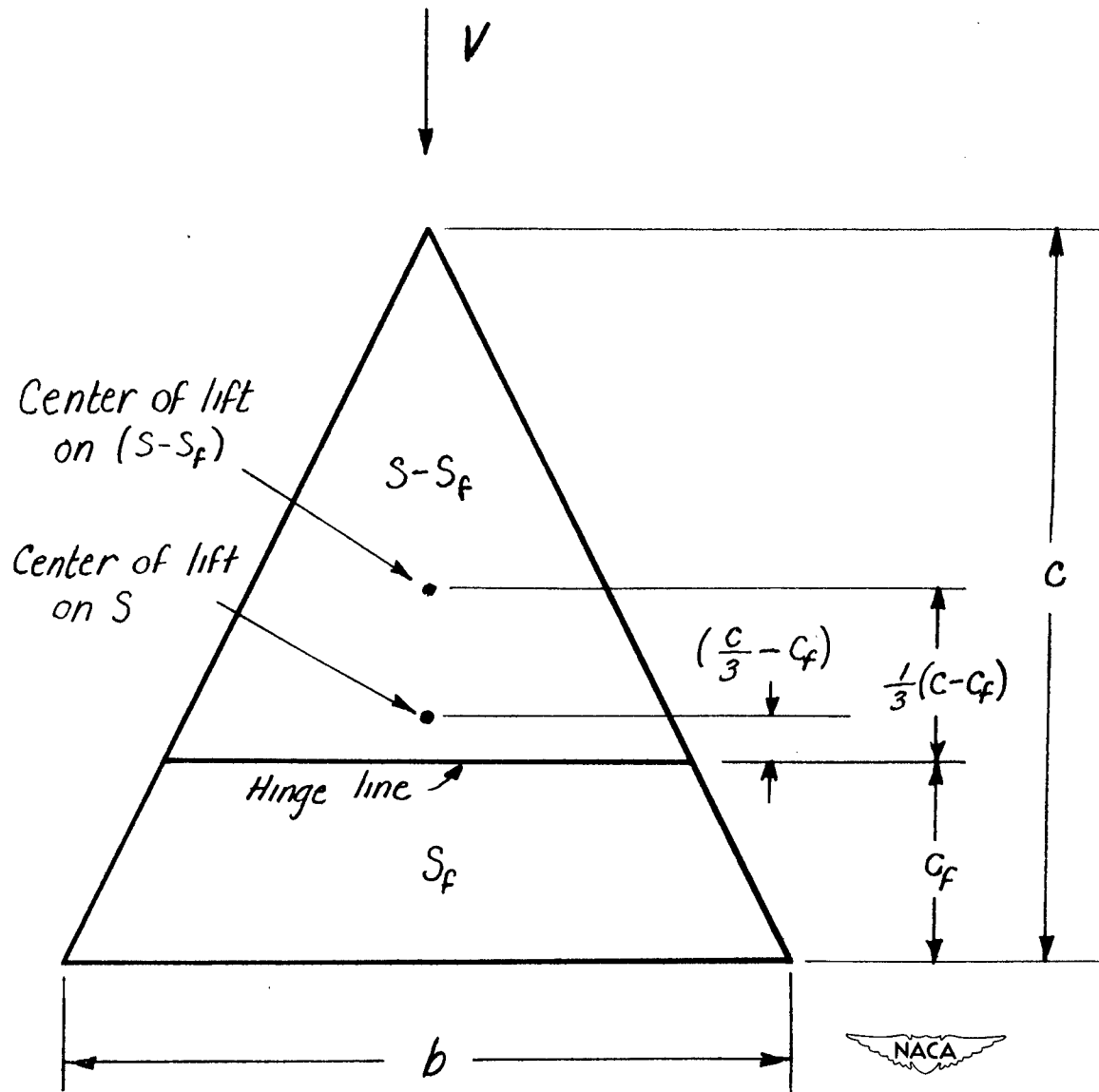

Figure 9.- Notation used in derivation of hinge moment due to angle of attack.

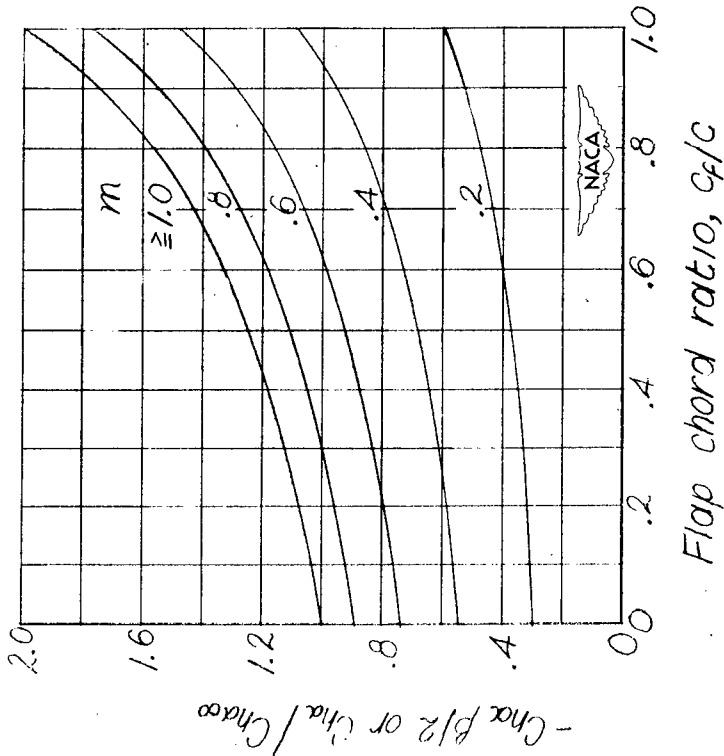

Figure 10. - Characteristics of hinge moment due to angle of attack. Constant-chord full-span control surfaces on triangular wings.

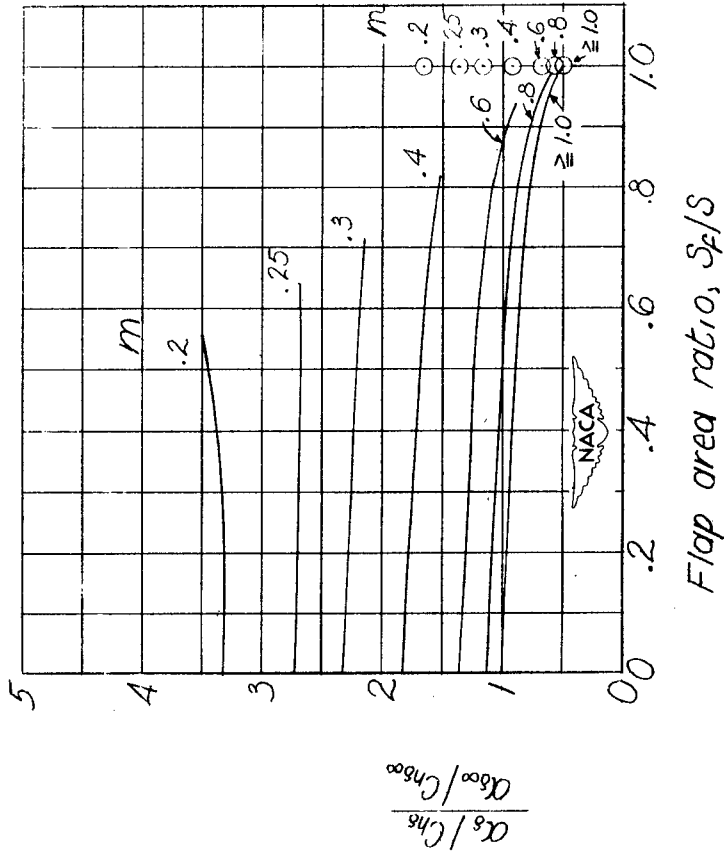

Figure 11. - Relative efficiency of constant-chord full-span control surfaces on triangular wings as compared with two-dimensional wing-flap combination having same flap area ratio.

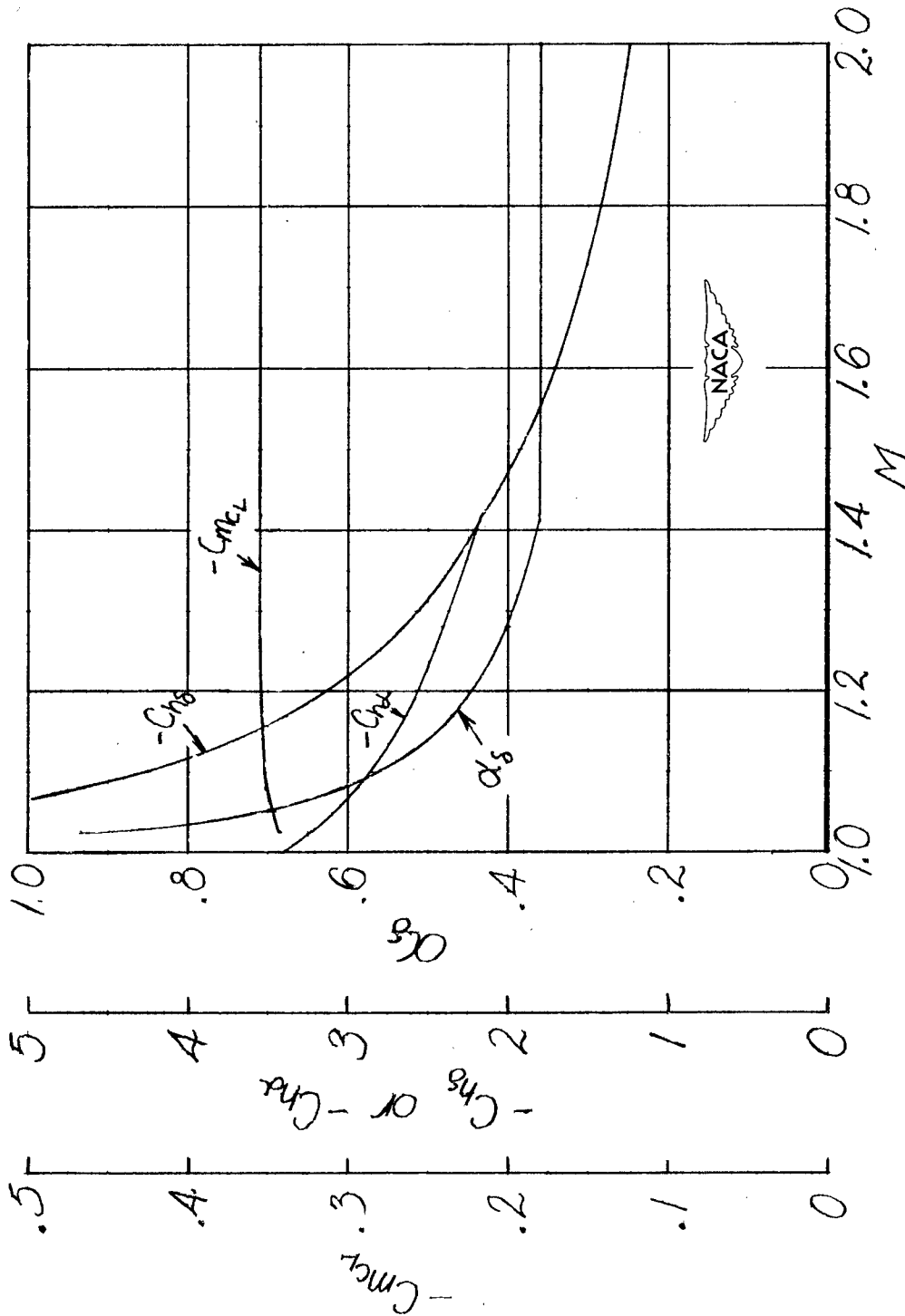

Figure 12. - Sample variation of control-surface characteristics with Mach number.  $\epsilon_s$ , 45°;  $q/c$ , 0.2.