

T.N. 1678

NATIONAL ADVISORY COMMITTEE
FOR AERONAUTICS

TECHNICAL NOTE

No. 1678

THEORETICAL WAVE DRAG AND LIFT OF THIN
SUPERSONIC RING AIRFOILS

By Harold Mirels

Flight Propulsion Research Laboratory
Cleveland, Ohio



Washington
August 1948

Reproduced From
Best Available Copy

DISTRIBUTION STATEMENT A
Approved for Public Release
Distribution Unlimited

20000808 154

DTIC QUALITY INSPECTED 4

AQM00-11-3673

NATIONAL ADVISORY COMMITTEE FOR AERONAUTICS

TECHNICAL NOTE NO. 1678

THEORETICAL WAVE DRAG AND LIFT OF THIN
SUPERSONIC RING AIRFOILS

By Harold Mirels

SUMMARY

An approximate linearized solution is presented for the wave drag and lift of an airfoil generated by rotating a thin supersonic profile about an axis parallel, or nearly parallel, to its chord. The aerodynamic coefficients are obtained from a surface distribution of sources, of strengths proportional to the local airfoil slopes, about a cylinder whose radius and chord equal those of the original ring airfoil. This source distribution satisfies the boundary conditions when the part of the wing within the forward Mach cone from a point on the wing surface departs only slightly from a plane. The solution is therefore accurate for ring airfoils having chords that are small in comparison to the radius of rotation.

The lift coefficient of thin supersonic ring airfoils, based on the airfoil-surface area, is one-half the Ackeret value for a two-dimensional wing of infinite span. The drag coefficient is equal to the sum of the Ackeret value for the given profile (with the ring airfoil at zero angle of attack) and the induced drag coefficient. These coefficients are probably within 5 percent of the correct linearized values for ring airfoils whose chord-radius parameter (chord divided by the product of the radius and the cotangent of the Mach angle) is within the range from 0 to 0.20.

INTRODUCTION

The linearized solution for the aerodynamic coefficients of a thin supersonic airfoil whose chord elements form a flat surface is currently in an advanced stage. Conical superposition has been extensively used to determine performance when the plan form is bounded by straight-line segments. Surface source distributions have been used to develop analytical and numerical methods of solution (references 1 and 2) for an arbitrarily shaped plan-form boundary. However, airfoils whose chord surface is not flat have been comparatively neglected.

Wave drag and lift are evaluated herein for the supersonic ring airfoil generated by rotating a thin sharp-edged profile section about an axis parallel, or nearly parallel, to its chord. The chord-radius ratio of the ring airfoil is assumed to be small. A surface source distribution, as originally proposed in reference 3 for essentially flat airfoils, is used as the basis for the analysis. The limiting chord-radius ratios for which this source distribution gives a valid linearized solution are estimated by comparing the results for the external surface of the ring airfoil to those obtained by the numerical method of reference 4. The ring airfoil in subsonic flight is considered in reference 5.

The investigation, conducted at the NACA Cleveland Laboratory, was completed during December, 1947.

SYMBOLS

The following symbols are used in this report:

- C_D drag coefficient based on wing surface, $\left(\frac{D}{\frac{1}{2}\rho U^2 2\pi\bar{r}c} \right)$
- C_F skin-friction drag coefficient based on wing-surface area, $\left(\frac{\text{friction drag}}{\frac{1}{2}\rho U^2 2\pi\bar{r}c} \right)$
- C_L lift coefficient based on wing-surface area, $\left(\frac{L}{\frac{1}{2}\rho U^2 2\pi\bar{r}c} \right)$
- C_p pressure coefficient, $\left(\frac{\text{incremental pressure}}{\frac{1}{2}\rho U^2} \right)$
- c wing chord
- D drag
- L lift
- M free-stream Mach number
- q local source strength per unit area
- \bar{r} mean radius of airfoil

- s area of integration
- t maximum profile thickness
- t/c thickness ratio
- U free-stream velocity, taken in positive x direction
- w perturbation velocity normal to source surface
- x, ξ }
 y, η } Cartesian coordinate system
 z }
- x, ξ }
 r } cylindrical coordinate system
 θ, ω }
- α angle of attack, radians
- α_0 angle between chord of profile section and axis of ring airfoil, radians
- β cotangent of Mach angle, $(\sqrt{M^2-1})$
- λ local slope of wing surface with respect to direction of free-stream velocity
- ρ free-stream density
- σ local slope of wing surface with respect to chord
- φ perturbation-velocity potential
- Subscripts:
- e external surface of ring airfoil
- i internal surface of ring airfoil

696

METHOD OF ANALYSIS

The linearized equation for the perturbation-velocity potential of an irrotational, compressible fluid is given by

$$(1 - M^2) \frac{\partial^2 \varphi}{\partial x^2} + \frac{\partial^2 \varphi}{\partial y^2} + \frac{\partial^2 \varphi}{\partial z^2} = 0 \quad (1)$$

A general solution of equation (1) can be obtained from a surface distribution of sources. The potential at a point in the flow field is the sum of the contributions of the elemental sources in the forward Mach cone from that point. If the source surface is in the x, y plane, the potential at a point in the x, y plane is given by

$$\varphi = - \iint_S \frac{q d\xi d\eta}{\sqrt{(x - \xi)^2 - \beta^2 (y - \eta)^2}} \quad (2)$$

where q is the function defining the source-strength distribution. The coordinate system and the limits of integration are illustrated in figure 1(a).

The induced normal perturbation velocity at a point on, or an infinitesimal distance from, a plane containing sources is simply a function of the local source strength and equals $q\pi$. (See reference 3.) Thus, if a planar distribution of sources is to represent the flow about the top or bottom surface of a thin supersonic airfoil whose chord surface is flat, the boundary conditions are satisfied by setting

$$q = \frac{w}{\pi} = \frac{\lambda U}{\pi} \quad (3)$$

where $\lambda = w/U$ is the local slope of the wing surface in the free-stream direction. If the sources are assumed to be in the x, y plane, the equation for the velocity potential becomes

$$\varphi = - \frac{U}{\pi} \iint_S \frac{\lambda d\xi d\eta}{\sqrt{(x - \xi)^2 - \beta^2 (y - \eta)^2}} \quad (4)$$

The following sign convention for λ will be used: When the surface normal projecting into the stream has a component in the positive x direction, the slope is considered negative; when the surface normal has a component in the negative x direction, the slope is considered positive. For a flat plate at angle of attack α , the slopes for the upper and lower surfaces are constant and have the values $\lambda = -\alpha$ and $\lambda = \alpha$, respectively.

The potential flow about a thin-ring airfoil can be found from a source distribution about a circular cylinder whose axis is parallel to the free-stream direction and whose radius and chord equal those of the original airfoil; however, the function defining the source-strength distribution remains to be determined. In the limiting case of a thin-ring airfoil having a small chord-radius ratio, the wing section in the forward Mach cone from a point on the wing departs only slightly from a plane. From the previous discussion, a source distribution defined by the local wing slope $q = \lambda U/\pi$ adequately satisfies the boundary conditions. This representation is directly analogous to the solution of an essentially flat wing in that allowance is made for variations of wing slope, but the departure of the wing surface from a plane is considered negligible. The velocity potential for points on a ring airfoil of small chord, expressed in cylindrical coordinates, is then

$$\varphi = -\frac{U}{\pi} \iint_S \frac{\lambda d\xi d\omega}{\sqrt{\left(\frac{x-\xi}{\bar{r}}\right)^2 - \beta^2 (\theta - \omega)^2}} \quad (5)$$

where $\bar{r}d\omega$, $\omega\bar{r}$, and $\theta\bar{r}$ have replaced $d\eta$, η , and y of equation (4). The coordinate system is illustrated in figure 1(b).

The normal perturbation velocity at a point on a three-dimensional source surface is not a simple function of the local source strength. Equation (3), and consequently equation (5), therefore do not satisfy the boundary conditions when the chord-radius ratio of a ring airfoil is sufficiently large that the deviation from a plane of the chord surface in the forward Mach cone is no longer negligible.

WAVE DRAG AND LIFT OF CYLINDRICAL-RING AIRFOIL

A cylindrical-ring airfoil is a ring airfoil of zero profile thickness, camber, and flare ($\alpha_0 = 0$). The velocity potential

of such an airfoil may be found if the function defining λ at all points is known. For small angles of attack and a small chord, this function is shown in appendix A to be

$$\lambda_e = -\alpha \sin \omega \quad (6)$$

$$\lambda_i = \alpha \sin \omega \quad (6a)$$

The expression for the velocity potential of the external surface of a cylindrical-ring airfoil results from the substitution of equation (6) into equation (5):

$$\begin{aligned} \varphi_e &= -\frac{U}{\pi} \iint_s \frac{(-\alpha \sin \omega) d\xi d\omega}{\sqrt{\left(\frac{x-\xi}{r}\right)^2 - \beta^2 (\theta - \omega)^2}} \\ &= \frac{U\alpha}{\pi} \int_0^x d\xi \int_{\theta - \frac{x-\xi}{\beta r}}^{\theta + \frac{x-\xi}{\beta r}} \frac{\sin \omega d\omega}{\sqrt{\left(\frac{x-\xi}{r}\right)^2 - \beta^2 (\theta - \omega)^2}} \end{aligned} \quad (7)$$

It is desirable to solve equation (7) directly for $\partial\varphi_e/\partial x$. In appendix B, this solution shows that

$$\frac{\partial\varphi_e}{\partial x} = \frac{U\alpha \sin \theta}{\beta} \left[1 - \frac{1}{4} \left(\frac{x}{\beta r}\right)^2 + \frac{1}{64} \left(\frac{x}{\beta r}\right)^4 - \dots \right] \quad (8)$$

The pressure coefficient for a point on the external surface, based on the linearized Bernoulli equation, is then

$$\begin{aligned} c_{p,e} &= -\frac{2}{U} \frac{\partial\varphi_e}{\partial x} \\ &= \frac{-2\alpha \sin \theta}{\beta} \left[1 - \frac{1}{4} \left(\frac{x}{\beta r}\right)^2 + \frac{1}{64} \left(\frac{x}{\beta r}\right)^4 - \dots \right] \end{aligned} \quad (9)$$

The pressure coefficient for the internal surface is the negative of that for the external surface.

The lift and drag coefficients, referred to the airfoil-surface area, may be obtained from the respective summations of the effective lift and drag forces acting on each element of area:

$$C_L = \frac{2 \int_0^c dx \int_{-\frac{\pi}{2}}^{\frac{\pi}{2}} [(C_{p,i} - C_{p,e}) \sin \theta] \bar{r} d\theta}{2 \int_0^c dx \int_{-\frac{\pi}{2}}^{\frac{\pi}{2}} \bar{r} d\theta} \quad (10)$$

$$C_D = \frac{2 \int_0^c dx \int_{-\frac{\pi}{2}}^{\frac{\pi}{2}} (C_{p,i} \lambda_i + C_{p,e} \lambda_e) \bar{r} d\theta}{2 \int_0^c dx \int_{-\frac{\pi}{2}}^{\frac{\pi}{2}} \bar{r} d\theta} \quad (11)$$

The results for the lift and drag coefficients show that

$$C_L = \frac{2\alpha}{\beta} \left[1 - \frac{1}{12} \left(\frac{c}{\beta \bar{r}} \right)^2 + \frac{1}{320} \left(\frac{c}{\beta \bar{r}} \right)^4 - \dots \right] \quad (12)$$

and

$$C_D = \frac{2\alpha^2}{\beta} \left[1 - \frac{1}{12} \left(\frac{c}{\beta \bar{r}} \right)^2 + \frac{1}{320} \left(\frac{c}{\beta \bar{r}} \right)^4 - \dots \right] \quad (13)$$

The series in equations (9), (12), and (13) converge very rapidly for values of $x/(\beta \bar{r})$ and $c/(\beta \bar{r})$ that are sufficiently small to justify the use of a source distribution defined by the local

wing slopes. No appreciable error will be introduced by assuming these series to equal 1. The pressure coefficient then becomes simply the Ackeret value corresponding to the local slope:

$$C_{p,e} = \frac{2}{\beta} (-\alpha \sin \theta) \quad (14)$$

This result indicates that the spanwise variation of slope in the forward Mach cone, due to chord-surface curvature, may be neglected when calculating the pressure coefficient at points on an airfoil by means of a source distribution defined by $q = \lambda U/\pi$. Therefore equation (14) could have been obtained directly from equation (7) by using the mean value $\sin \theta$ instead of $\sin \omega$.

Similarly, the lift and drag coefficients become

$$C_L = \frac{2\alpha}{\beta} \quad (15)$$

and

$$C_D = \frac{2\alpha^2}{\beta} \quad (16)$$

Both coefficients are one-half the Ackeret values for a flat-plate airfoil of infinite span.

WAVE DRAG AND LIFT OF RING AIRFOIL OF GENERAL PROFILE

In the general case, a ring-airfoil profile section has camber and thickness and its chord makes a finite angle with the axis of the airfoil. The local airfoil slopes are then given by the expressions

$$\lambda_e = \sigma_e - (\alpha_0 + \alpha \sin \theta) \quad (17)$$

$$\lambda_i = \sigma_i + (\alpha_0 + \alpha \sin \theta) \quad (17a)$$

For a small chord, the pressure coefficient has been shown to equal approximately the Ackeret value corresponding to the local slope.

$$C_{p,e} = \frac{2}{\beta} [\sigma_e - (\alpha_0 + \alpha \sin \theta)] \quad (18)$$

$$C_{p,i} = \frac{2}{\beta} [\sigma_i + (\alpha_0 + \alpha \sin \theta)] \quad (18a)$$

The lift coefficient obtained by substituting these pressure coefficients in equation (10) equals that of the cylindrical-ring airfoil. Thus the lift coefficient of a ring airfoil is independent of its profile slope.

The drag coefficient is

$$C_D = \frac{2\alpha^2}{\beta} + \frac{4\alpha_0^2}{\beta} + \frac{2}{\beta c} \int_0^c (\sigma_e^2 + \sigma_i^2) dx \quad (19)$$

The first term of equation (19) defines the induced drag due to lift and is one-half the Ackeret value for induced drag coefficient. The last two terms represent the drag of the ring airfoil at zero angle of attack and equal the drag coefficient of an Ackeret airfoil (having the given profile section) at angle of attack α_0 .

LIFT-DRAG RATIOS OF RING AIRFOIL

A calculation can be made to illustrate the order of magnitude of lift-drag ratios obtainable from a ring-type airfoil. For a symmetrical diamond profile, no flare, and a skin-friction drag coefficient C_f , the lift-drag ratio is given by

$$\frac{L}{D} = \frac{\frac{2\alpha}{\beta}}{\frac{2\alpha^2}{\beta} + \frac{4}{\beta} \left(\frac{t}{c}\right)^2 + C_f} \quad (20)$$

For small values of t/c and C_f , the L/D performance approaches that of an Ackeret airfoil. With increasing t/c , the L/D approaches one-half the value for the corresponding Ackeret airfoil. Equation (20) can be maximized to give the angle of attack at which $(L/D)_{\max}$ occurs for a given t/c and βC_f . The result shows

$$\alpha = \sqrt{2\left(\frac{t}{c}\right)^2 + \frac{\beta}{2} C_f} \quad (21)$$

and the corresponding value of $(L/D)_{\max}$ is

$$\left(\frac{L}{D}\right)_{\max} = \frac{1}{2 \sqrt{2 \left(\frac{t}{c}\right)^2 + \frac{\beta}{2} C_f}} \quad (22)$$

Equation (22) is plotted in figure 2. The values of airfoil lift coefficient at which $(L/D)_{\max}$ occurs are cross-plotted in this figure. As shown by equations (15), (21), and (22), this lift coefficient is the reciprocal of $(L/D)_{\max}$.

Little information is available on the value of friction drag coefficients at supersonic speeds. The mean value $C_f = 0.006$ is sometimes used for thin supersonic airfoils. If C_f is assumed independent of Mach number, figure 2 indicates that $(L/D)_{\max}$ decreases with increased flight speed, but this effect becomes less pronounced with larger values of t/c .

Because the flare was considered zero and a diamond profile has the lowest possible wave drag for a given thickness ratio, the values for $(L/D)_{\max}$ presented in figure 2 are the largest values theoretically obtainable from a ring-type airfoil.

VALUES OF $c/(\beta r)$ FOR WHICH AERODYNAMIC

COEFFICIENTS ARE ACCURATE

The values of chord-radius ratio beyond which equations (15) and (19) are no longer valid can be estimated by comparing the external lift and drag coefficients as indicated by these equations to the values found from the numerical method of reference 4, which is an extension of the solution for slender, pointed-nose bodies of revolution presented in references 6 and 7. A line distribution of sources and doublets is placed along the axis of an open-nosed body of revolution, and the strength distribution is so adjusted that the flow and cross-flow components of the free-stream velocity follow the external contour of the body. The resulting values for external wave drag and lift may be considered the correct linearized solution. The internal flow, however, is not properly described.

By use of the line-doublet distribution of reference 4, the lift coefficient for the external surface of a cylindrical-ring airfoil, expressed in the form $\beta C_{L,e}/\alpha$, was found to be solely a

function of the airfoil parameter $c/(\beta\bar{r})$. The relation is shown in figure 3. The decrease in lift with increase in chord indicates that the downstream sections of the cylindrical-ring airfoil have progressively lower external lift. Equation (15), based on the surface source distribution, yields a constant value for $\beta C_{L,e}/\alpha$, but the discrepancy between the two methods is less than 5 percent for values of $c/(\beta\bar{r})$ up to 0.20.

Computations for the external lift and drag of finite-thickness ring airfoils indicate that the effect of thickness ratio on the discrepancy between the two methods is small for the magnitudes of thickness ratio permitted by the linearized theory. These discrepancies depend primarily on the value of $c/(\beta\bar{r})$. This result is to be expected, as chord-plane curvature, and not thickness ratio, is the source of the difference. If the discrepancy for the internal surface is assumed to be of the same order as that for the external surface, the generalization may be made that the coefficients expressed in equations (15) and (19) are correct to within 5 percent for values of $c/(\beta\bar{r})$ up to 0.20. The degree of error may be estimated by the plot of figure 3.

SUMMARY OF RESULTS

An approximate linearized solution for the aerodynamic coefficients of ring airfoils having small chord-radius ratios indicates that the lift coefficient, based on the wing-surface area, is independent of the profile shape and equals one-half the Ackeret value for a two-dimensional wing of infinite span. The drag coefficient equals the Ackeret value for the given profile (with the ring airfoil at zero angle of attack) plus the induced drag coefficient. These coefficients are probably within 5 percent of the correct linearized solution for values of chord-radius ratio from 0 to 0.20.

Flight Propulsion Research Laboratory,
National Advisory Committee for Aeronautics,
Cleveland, Ohio, April 30, 1948.

APPENDIX A

FUNCTION DEFINING LOCAL SLOPES ON CYLINDRICAL RING AIRFOIL

A cylindrical ring airfoil of small chord and at a small angle of attack is assumed,

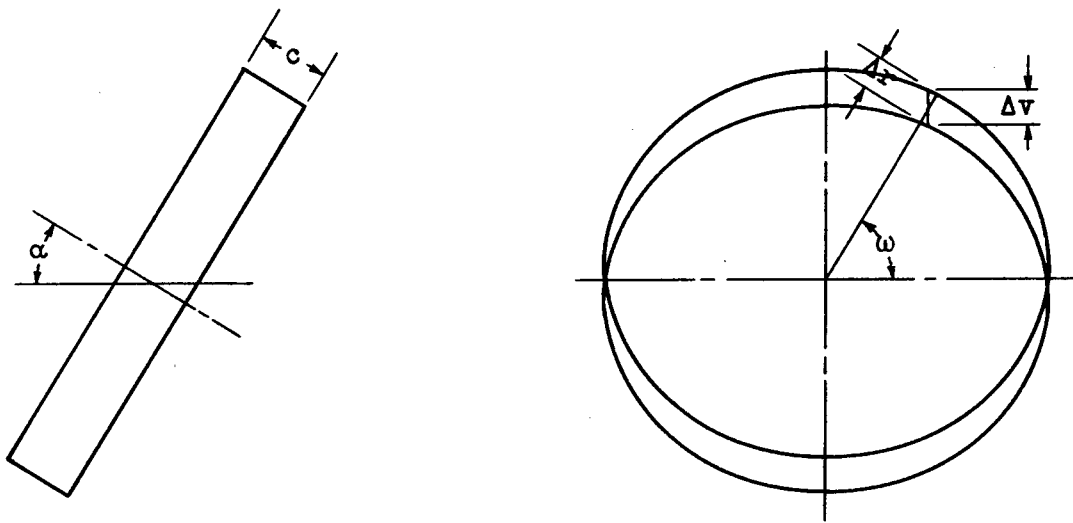

060

for which

Δv vertical displacement between corresponding points on leading and trailing edges

Δr radial distance between corresponding points on leading and trailing edges

Then

$$\Delta v = c \sin \alpha$$

$$\Delta r = \Delta v \sin \omega$$

$$= c \sin \alpha \sin \omega$$

But

$$\lambda = \frac{\Delta r}{c} = \sin \alpha \sin \omega$$

Inasmuch as α is small

$$\lambda = \alpha \sin \omega$$

and with the proper sign convention

$$\lambda_e = -\alpha \sin \omega$$

and

$$\lambda_i = \alpha \sin \omega$$

APPENDIX B

SOLUTION FOR $\frac{\partial \varphi}{\partial x}$ FROM VELOCITY-POTENTIAL EQUATION

From equation (7)

$$\varphi_e = \frac{U\alpha}{\pi} \int_0^x d\xi \int_{\theta - \frac{x-\xi}{\beta\bar{r}}}^{\theta + \frac{x-\xi}{\beta\bar{r}}} \frac{\sin \omega d\omega}{\sqrt{\left(\frac{x-\xi}{\bar{r}}\right)^2 - \beta^2 (\theta - \omega)^2}} \quad (B1)$$

Because $\sin \omega$ is independent of ξ , the order of integration of equation (B1) can be reversed and the equation integrated with respect to ξ . The resulting expression for φ_e can then be differentiated with respect to x to yield a line integral equation for $\partial\varphi_e/\partial x$. Reference 1 shows that the result is equivalent to a line integration along the leading edge $\xi=0$ of the airfoil.

Therefore,

$$\begin{aligned} \frac{\partial \varphi_e}{\partial x} &= \frac{U\alpha}{\pi} \int_{\theta - x/(\beta\bar{r})}^{\theta + x/(\beta\bar{r})} \frac{\sin \omega d\omega}{\sqrt{\left(\frac{x}{\bar{r}}\right)^2 - \beta^2 (\theta - \omega)^2}} \\ &= \frac{U\alpha}{\pi\beta} \int_{\theta - x/(\beta\bar{r})}^{\theta + x/(\beta\bar{r})} \frac{\sin \omega d\omega}{\sqrt{-\omega^2 + 2\omega\theta - \theta^2 + \frac{x^2}{\bar{r}^2\beta^2}}} \end{aligned} \quad (B2)$$

Integrating by parts gives

$$\frac{\partial \varphi_e}{\partial x} = \frac{U}{\pi} \frac{\alpha}{\beta} \left\{ \pi \sin \theta \cos \frac{x}{\beta\bar{r}} + \int_{\theta - x/(\beta\bar{r})}^{\theta + x/(\beta\bar{r})} \cos \omega \sin^{-1} \left[\frac{\theta - \omega}{x/(\beta\bar{r})} \right] d\omega \right\} \quad (B3)$$

Let

$$\frac{\theta - \omega}{x/(\beta r)} = z$$

Then

$$\int_{\theta-x/(\beta r)}^{\theta+x/(\beta r)} \cos \omega \sin^{-1} \left[\frac{\theta - \omega}{x/(\beta r)} \right] d\omega = - \frac{x}{\beta r} \int_1^{-1} \cos \left(\theta - \frac{zx}{\beta r} \right) \sin^{-1} z dz$$

$$= - \frac{x}{\beta r} \int_1^{-1} \left(\cos \theta \cos \frac{zx}{\beta r} + \sin \theta \sin \frac{zx}{\beta r} \right) \sin^{-1} z dz$$

(B4)

And by sine and cosine series expansions

$$= - \frac{x}{\beta r} \cos \theta \int_1^{-1} \left[1 - \frac{1}{2!} \left(\frac{zx}{\beta r} \right)^2 + \frac{1}{4!} \left(\frac{zx}{\beta r} \right)^4 - \dots \right] \sin^{-1} z dz$$

$$- \frac{x}{\beta r} \sin \theta \int_1^{-1} \left[\left(\frac{zx}{\beta r} \right) - \frac{1}{3!} \left(\frac{zx}{\beta r} \right)^3 + \dots \right] \sin^{-1} z dz$$

(B5)

But

$$\int_1^{-1} z^n \sin^{-1} z dz = 0$$

for n equal to a positive even integer or zero, and

$$\int_1^{-1} z^n \sin^{-1} z dz = \frac{\pi}{n+1} \left(-1 + \frac{n}{n+1} \times \frac{n-2}{n-1} \times \frac{n-4}{n-3} \dots \frac{1}{2} \right)$$

for n equal to a positive odd integer. Therefore

$$\int_{\theta-x/(\beta\bar{r})}^{\theta+x/(\beta\bar{r})} \cos \omega \sin \left[\frac{\theta - \omega}{x/(\beta\bar{r})} \right] d\omega = -\frac{x}{\beta\bar{r}} \sin \theta \left[\frac{x}{\beta\bar{r}} \left(\frac{\pi}{2} \right) \left(-1 + \frac{1}{2} \right) \right. \\ \left. - \frac{1}{3!} \left(\frac{x}{\beta\bar{r}} \right)^3 \frac{\pi}{4} \left(-1 + \frac{3 \times 1}{4 \times 2} \right) + \frac{1}{5!} \left(\frac{x}{\beta\bar{r}} \right)^5 \frac{\pi}{6} \left(-1 + \frac{5 \times 3 \times 1}{6 \times 4 \times 2} \right) - \dots \right] \\ = -\pi \sin \theta \left[\cos \frac{x}{\beta\bar{r}} - 1 + \left(\frac{x}{\beta\bar{r}} \right)^2 \frac{1}{2!} \times \frac{1}{2} - \left(\frac{x}{\beta\bar{r}} \right)^4 \frac{1}{4!} \times \frac{3 \times 1}{4 \times 2} \right. \\ \left. + \left(\frac{x}{\beta\bar{r}} \right)^6 \frac{1}{6!} \times \frac{5 \times 3 \times 1}{6 \times 4 \times 2} - \dots \right] \quad (B6)$$

Substituting equation (B6) in equation (B3) gives

$$\frac{\partial \varphi_e}{\partial x} = \frac{U \alpha}{\pi \beta} \left\{ \pi \sin \theta \cos \frac{x}{\beta\bar{r}} - \pi \sin \theta \cos \frac{x}{\beta\bar{r}} \right. \\ \left. + \pi \sin \theta \left[1 - \left(\frac{x}{\beta\bar{r}} \right)^2 \frac{1}{2!} \times \frac{1}{2} + \left(\frac{x}{\beta\bar{r}} \right)^4 \frac{1}{4!} \times \frac{3 \times 1}{4 \times 2} \right. \right. \\ \left. \left. - \left(\frac{x}{\beta\bar{r}} \right)^6 \frac{1}{6!} \times \frac{5 \times 3 \times 1}{6 \times 4 \times 2} + \dots \right] \right\} \\ = \frac{U \alpha}{\beta} \sin \theta \left[1 - \left(\frac{x}{\beta\bar{r}} \right)^2 \times \frac{1}{4} + \left(\frac{x}{\beta\bar{r}} \right)^4 \times \frac{1}{64} - \dots \right] \quad (B7)$$

REFERENCES

1. Eppard, John C.: Theoretical Distribution of Lift on Thin Wings at Supersonic Speeds (An Extension). NACA TN No. 1585, 1948.
2. Cohen, Clarence B., and Eppard, John C.: Graphical Method of Obtaining Theoretical Lift Distributions on Thin Wings at Supersonic Speeds. NACA TN No. 1676, 1948.
3. Puckett, Allen E.: Supersonic Wave Drag of Thin Airfoils. Jour. Aero. Sci., vol. 13, no. 9, Sept. 1946, pp. 475-484.
4. Brown, Clinton E., and Parker, Herman M.: A Method for the Calculation of External Lift, Moment, and Pressure Drag of Slender Open-Nose Bodies of Revolution at Supersonic Speeds. NACA ACR No. L5L29, 1946.
5. Ribner, Herbert S.: The Ring Airfoil in Nonaxial Flow. Jour. Aero. Sci., vol. 14, no. 9, Sept. 1947, pp. 529-530.
6. von Kármán, Theodor, and Moore, Norton B.: Resistance of Slender Bodies Moving with Supersonic Velocities, with Special Reference to Projectiles. Trans. A.S.M.E., vol. 54, no. 23, Dec. 15, 1932, pp. 303-310.
7. Tsien, Hsue-Shen: Supersonic Flow over an Inclined Body of Revolution. Jour. Aero. Sci., vol. 5, no. 12, Oct. 1938, pp. 480-483.

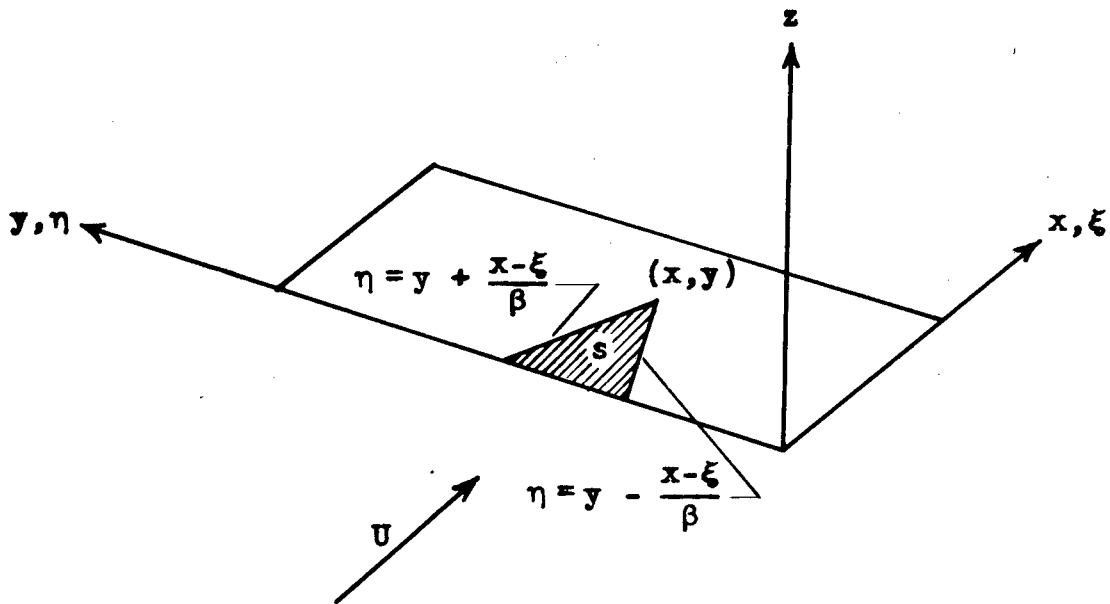

(a) Source distribution in x,y plane.

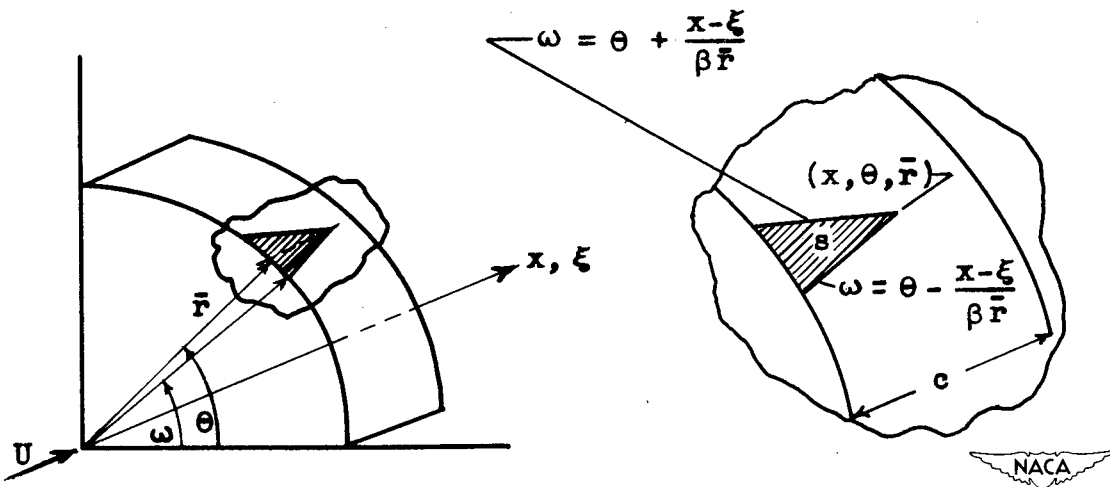

(b) Source distribution about circular cylinder (first quadrant shown).

Figure 1. - Coordinate systems and limits of integration for surface source distributions.

969

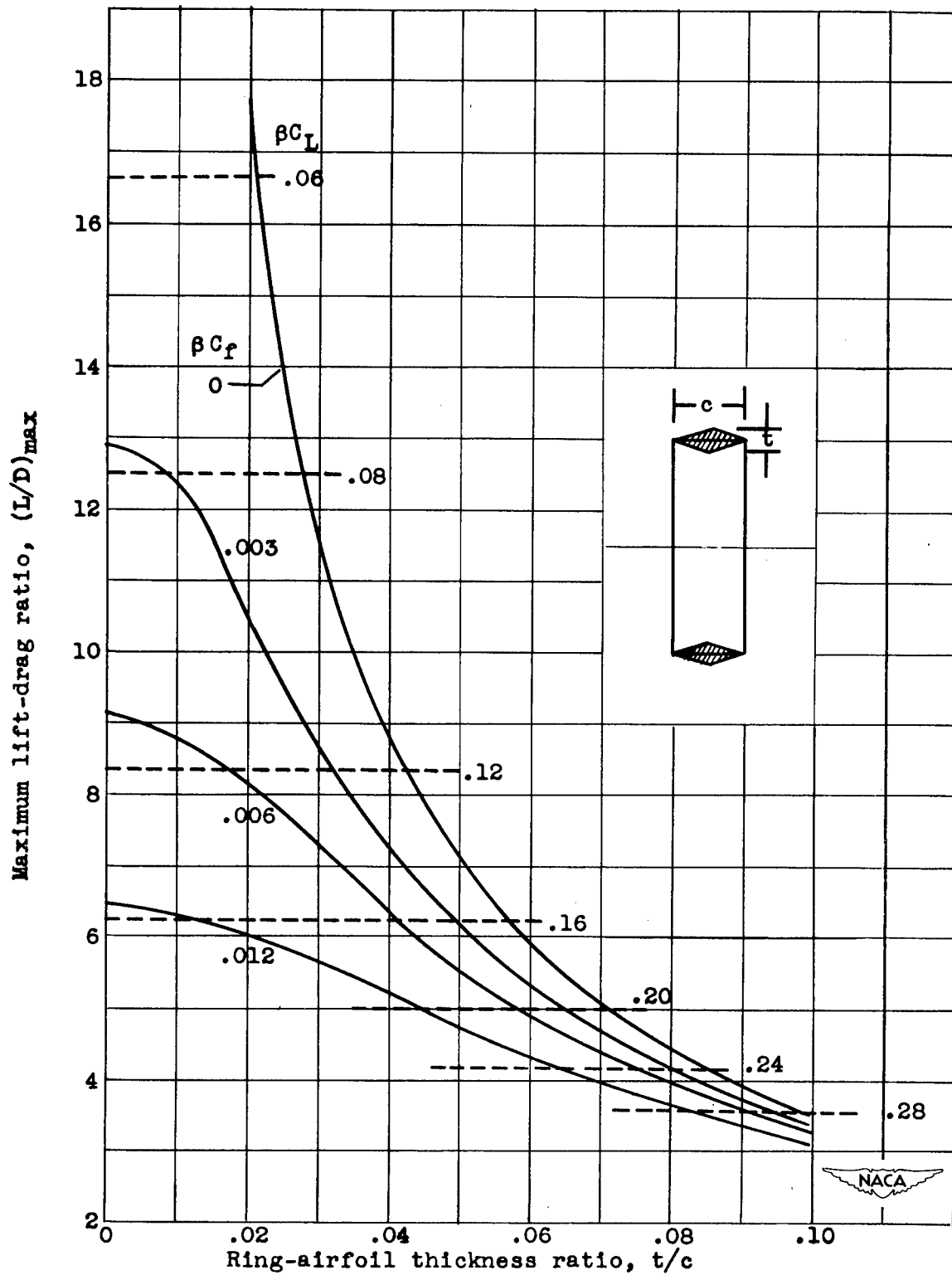

Figure 2. - Maximum lift-drag ratios obtainable from ring airfoil having symmetrical diamond profile and no flare.

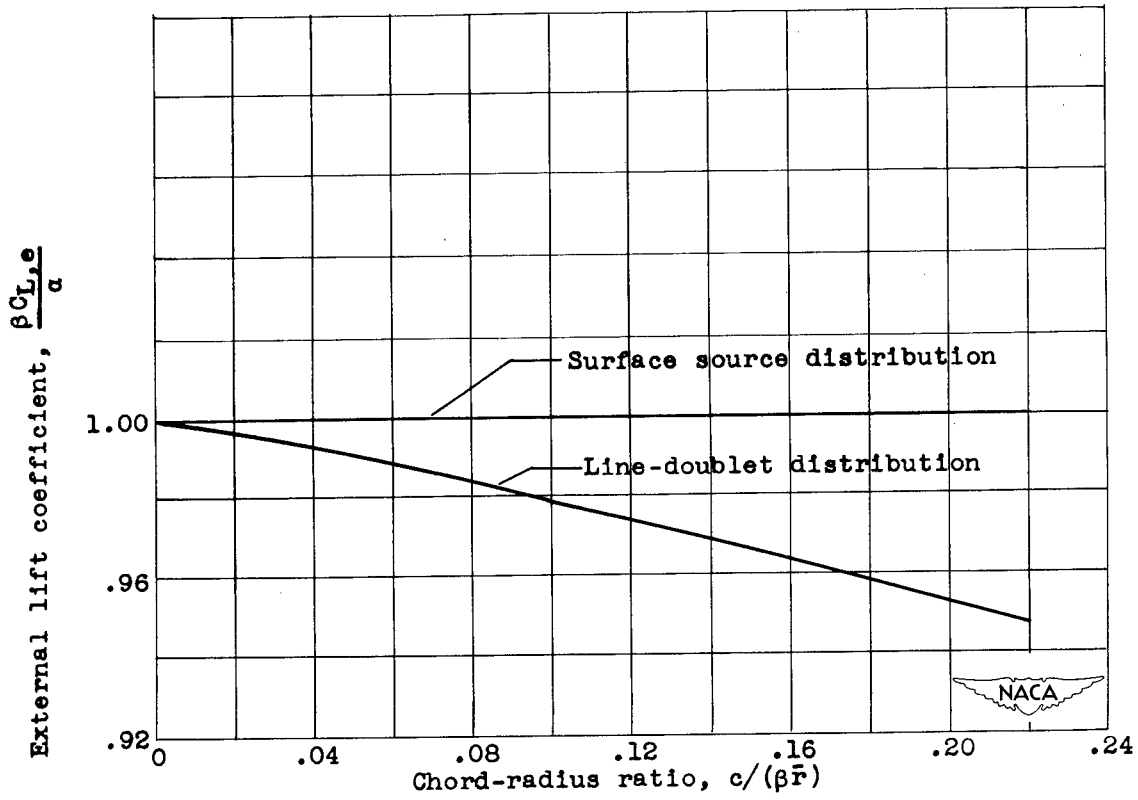

Figure 3. - External lift coefficients of cylindrical-ring airfoils as indicated by line-doublet distribution of reference 4 and by surface source distribution.