

NATIONAL ADVISORY COMMITTEE FOR AERONAUTICS

TECHNICAL NOTE 2145

LIFT-CANCELLATION TECHNIQUE IN LINEARIZED
SUPERSONIC-WING THEORY

By Harold Mirels

Lewis Flight Propulsion Laboratory
Cleveland, Ohio

DISTRIBUTION STATEMENT A
Approved for Public Release
Distribution Unlimited



Washington
August 1950

20000803 219

Reproduced From
Best Available Copy

NATIONAL ADVISORY COMMITTEE FOR AERONAUTICS

TECHNICAL NOTE 2145

LIFT-CANCELLATION TECHNIQUE IN LINEARIZED
SUPERSONIC-WING THEORY

By Harold Mirels

SUMMARY

A lift-cancellation technique is presented for determining load distributions on thin wings at supersonic speeds. The technique retains certain features of the method recently introduced by Theodore R. Goodman, while simplifying and generalizing others.

A general expression is derived for the load distribution over a cancellation wing. This expression permits the determination of lift distributions on wings that cannot be solved by cancellation techniques based on the superposition of conical flows. The boundary conditions for either a subsonic leading edge or a subsonic trailing edge can be satisfied. Applications of the expression to swept wings having curvilinear plan forms and to wings having reentrant side edges are indicated.

INTRODUCTION

The method of lift cancellation for obtaining the lift distribution on thin wings at supersonic speeds was first suggested in reference 1. The lift distribution on a given wing is determined by canceling excess lift, through the use of a "cancellation wing," on a related plan form having a known loading. This approach has been applied by several authors (for example, references 2 to 4). The expressions provided in reference 1 are applicable for wings that can be generated by the superposition of conical fields.

A procedure is presented in reference 5 for determining lift on a more general class of plan forms than can be handled by conical superposition. The method utilizes a surface distribution of doublets and an inversion by means of Abel's integral equation and is equivalent to a lift cancellation.

This report, prepared at the NACA Lewis laboratory, retains certain features of reference 5 (that is, the use of a surface distribution of doublets and an inversion by means of Abel's integral equation), whereas other features are simplified and generalized. The simplification consists in eliminating steps in the procedure for obtaining lift distributions. The generalization consists in determining a solution that can be made to satisfy the boundary conditions for either a subsonic leading edge or a subsonic trailing edge (Kutta condition). The method of reference 5 yields only the Kutta solution. The lift-cancellation technique developed herein is illustrated by several examples.

In a concurrent investigation (reference 6), source distributions and integral-equation formulations have been applied to obtain the loading on a special series of cancellation wings. Reference 7 employs some of these cancellation wings for the determination of lift and moments on swept wings.

THEORY

The usual assumptions of an inviscid fluid and small perturbations are made. The velocity field consists of the free-stream velocity U (taken in the positive x -direction) plus the perturbation velocities u , v , and w . The wing boundary conditions are specified in the $z = 0$ plane.

The local lift coefficient ΔC_p may be expressed in terms of Δu . That is,

$$\Delta C_p = \frac{p_B - p_T}{q} = \frac{2(u_T - u_B)}{U} = \frac{2\Delta u}{U} \quad (1)$$

(All symbols used in this report are defined in appendix A.) Inasmuch as the local lift coefficient is directly proportional to Δu , Δu will be referred to as "lift" in later developments.

Lift-Cancellation Method

The lift distribution on a given wing is to be determined by canceling excess lift on a related wing with a known loading. The method is illustrated in figure 1. The wing for which the lift distribution is desired is shown in figure 1(a). The solution can be expressed as the two-dimensional wing (fig. 1(b)) minus a cancellation wing (fig. 1(c)). The loading in region I of the

cancellation wing equals the loading in the corresponding region of the two-dimensional wing and the upwash w in region II of the cancellation wing is zero. The loading of the two-dimensional wing minus that of the cancellation wing satisfies the boundary conditions for the flow about the given wing and is the desired solution.

The fundamental problem in the lift-cancellation method is then to determine the lift in region II of a cancellation wing subject to the condition $w = 0$ in this region and with the assumption of a known loading in region I. Solution of this problem is presented in the following sections.

Derivation of Lift-Cancellation Equations

The lift distribution in region II will be expressed in terms of quantities in region I.

Consider the cancellation wing shown in figure 2. The portion of the leading edge to the left of the origin coincides with a Mach line. The portion of the leading edge to the right (designated $r = r_1(s)$) is shown as a supersonic edge, although no restrictions as to a subsonic or supersonic edge are imposed. (A plan-form edge is subsonic or supersonic depending on whether the component of the free stream normal to the edge is subsonic or supersonic.) The line designated $r = r_2(s)$ separates region I and region II and is assumed to be subsonically inclined to the free stream at all points. This line corresponds to a plan-form edge of the wing for which the lift distribution is desired.

General solution for load distribution on cancellation wing. - The upwash field in the $z = 0$ plane (due to an arbitrary distribution of vorticity Δu and Δv) may be written, from reference 8,

$$w = \frac{\beta^2}{2\pi} \int \int_{\tau} \frac{[(y-y_0)\Delta v + (x-x_0)\Delta u] dx_0 dy_0}{[(x-x_0)^2 - \beta^2(y-y_0)^2]^{3/2}} \quad (2)$$

The symbol \int designates the finite part of an infinite integral, as defined in reference 9. Application of the finite-part concept to linearized supersonic-wing theory and the evaluation of the finite part of an infinite integral are discussed in references 8 and 10. For the present, it will suffice to state the fundamental definition of the finite part of an integral with a $3/2$ -power singularity, namely,

$$\int_a^x \frac{f(x_0) dx_0}{(x-x_0)^{3/2}} = \int_a^x \frac{[f(x_0)-f(x)] dx_0}{(x-x_0)^{3/2}} - \frac{2f(x)}{(x-a)^{1/2}} \quad (3)$$

By a transformation to the Mach coordinates of reference 11,

$$\left. \begin{aligned} x &= \frac{\beta}{M} (s+r) & r &= \frac{M}{2\beta} (x-\beta y) \\ y &= \frac{1}{M} (s-r) & s &= \frac{M}{2\beta} (x+\beta y) \\ \text{elemental area} &= \frac{2\beta}{M^2} dr ds \end{aligned} \right\} \quad (4)$$

equation (2) becomes

$$w = \frac{M}{8\pi} \iint_{\tau} \frac{[(s-s_0) \frac{\partial \Delta\phi}{\partial s_0} + (r-r_0) \frac{\partial \Delta\phi}{\partial r_0}] dr_0 ds_0}{[(r-r_0)(s-s_0)]^{3/2}} \quad (5)$$

Upon substitution of the limits of integration, as indicated in figure 2,

$$w = \frac{M}{8\pi} \left\{ \int_0^s \frac{ds_0}{(s-s_0)^{3/2}} \int_{r_1(s_0)}^r \frac{\frac{\partial \Delta\phi}{\partial r_0} dr_0}{(r-r_0)^{1/2}} + \int_0^s \frac{ds_0}{(s-s_0)^{1/2}} \int_{r_1(s_0)}^r \frac{\frac{\partial \Delta\phi}{\partial s_0} dr_0}{(r-r_0)^{3/2}} \right\} \quad (6)$$

Integrating by parts, noting that $\Delta\Phi = 0$ at $r_0 = r_1(s_0)$, and recalling the definition of the finite part (equation (3)) yield

$$\int_{r_1(s_0)}^r \frac{\frac{\partial \Delta\Phi}{\partial r_0} dr_0}{(r-r_0)^{1/2}} \equiv \lim_{r_0 \rightarrow r} \left\{ \frac{\Delta\Phi}{(r-r_0)^{1/2}} \Big|_{r_1(s_0)}^{r_0} - \frac{1}{2} \int_{r_1(s_0)}^{r_0} \frac{\Delta\Phi dr_0}{(r-r_0)^{3/2}} \right\}$$

$$\equiv -\frac{1}{2} \int_{r_1(s_0)}^r \frac{\Delta\Phi dr_0}{(r-r_0)^{3/2}} \quad (7)$$

Thus

$$\int_0^s \frac{ds_0}{(s-s_0)^{3/2}} \int_{r_1(s_0)}^r \frac{\frac{\partial \Delta\Phi}{\partial r_0} dr_0}{(r-r_0)^{1/2}} \equiv -\frac{1}{2} \int_0^s \frac{ds_0}{(s-s_0)^{3/2}} \int_{r_1(s_0)}^r \frac{\Delta\Phi dr_0}{(r-r_0)^{3/2}} \quad (8)$$

Similarly, reversing the order of integration (with appropriate changes in limits of integration), integrating by parts, and then returning to the original order of integration establish the identity

$$\int_0^s \frac{ds_0}{(s-s_0)^{1/2}} \int_{r_1(s_0)}^r \frac{\frac{\partial \Delta\Phi}{\partial s_0} dr_0}{(r-r_0)^{3/2}} \equiv -\frac{1}{2} \int_0^s \frac{ds_0}{(s-s_0)^{3/2}} \int_{r_1(s_0)}^r \frac{\Delta\Phi dr_0}{(r-r_0)^{3/2}} \quad (9)$$

1297

The right side of equations (8) and (9) are identical. Equation (6) can now be written as

$$w = -\frac{M}{8\pi} \int_0^s \frac{ds_0}{(s-s_0)^{3/2}} \int_{r_1(s_0)}^r \frac{\Delta\phi dr_0}{(r-r_0)^{3/2}} \quad (10)$$

For points in region II, $w = 0$ and equation (10) becomes

$$0 = \int_0^s \frac{ds_0}{(s-s_0)^{3/2}} \int_{r_1(s_0)}^r \frac{\Delta\phi dr_0}{(r-r_0)^{3/2}} \quad (11a)$$

or

$$0 = \int_0^s \frac{G(r, s_0) ds_0}{(s-s_0)^{3/2}} \quad (11b)$$

where

$$G(r, s_0) = \int_{r_1(s_0)}^r \frac{\Delta\phi dr_0}{(r-r_0)^{3/2}} \quad (12)$$

Equation (11b) is an integral equation for the unknown function $G(r, s_0)$. The solution (appendix B) is

$$G(r, s_0) = 0 \quad (13)$$

Thus,

$$0 = \int_{r_1(s_0)}^r \frac{\Delta\phi dr_0}{(r-r_0)^{3/2}} \equiv \int_{r_1(s_0)}^{r_2(s_0)} \frac{\Delta\phi_I dr_0}{(r-r_0)^{3/2}} + \int_{r_2(s_0)}^r \frac{\Delta\phi_{II} dr_0}{(r-r_0)^{3/2}}$$

or

$$\int_{r_2(s_0)}^r \frac{\Delta\varphi_{II} dr_0}{(r-r_0)^{3/2}} = - \int_{r_1(s_0)}^{r_2(s_0)} \frac{\Delta\varphi_I dr_0}{(r-r_0)^{3/2}} \quad (14)$$

The right side of equation (14) will be considered known. Equation (14) is then an integral equation for $\Delta\varphi_{II}$. The solution (appendix B) is

$$\Delta\varphi_{II} = \frac{\sqrt{r-r_2(s)}}{\pi} \int_{r_1(s)}^{r_2(s)} \frac{\Delta\varphi_I dr_0}{(r-r_0)\sqrt{r_2(s)-r_0}} \quad (15)$$

Equation (15) indicates that the doublet strength in region II, namely $\Delta\varphi_{II}$, can be obtained by a line integration along $s_0 = s$ in region I. The geometric interpretation of the various terms in equation (15) is shown in figure 3.

It can be shown, by expanding $\Delta\varphi_I$ in a Taylor's series about $r = r_2(s)$, that equation (15) yields a continuous solution ($\Delta\varphi_{II} = \Delta\varphi_I$) at $r = r_2(s)$. (A discontinuity in $\Delta\varphi$ implies a lifting line (reference 12) and is unrealistic.)

The lift distribution in region II can be expressed as

$$\begin{aligned} \Delta u_{II} &= \frac{\partial \Delta\varphi_{II}}{\partial x} = \frac{\partial \Delta\varphi_{II}}{\partial r} \frac{\partial r}{\partial x} + \frac{\partial \Delta\varphi_{II}}{\partial s} \frac{\partial s}{\partial x} \\ &= \frac{M}{2\beta} \left(\frac{\partial}{\partial r} + \frac{\partial}{\partial s} \right) \Delta\varphi_{II} \end{aligned}$$

or, from equation (15),

$$\frac{2\beta}{M} \Delta u_{II} = \left(\frac{\partial}{\partial r} + \frac{\partial}{\partial s} \right) \left[\frac{\sqrt{r-r_2(s)}}{\pi} \int_{r_1(s)}^{r_2(s)} \frac{\Delta\varphi_I dr_0}{(r-r_0)\sqrt{r_2(s)-r_0}} \right] \quad (16)$$

Differentiation yields (See appendix C.)

$$\Delta u_{II} = \frac{\sqrt{r-r_2(s)}}{\pi} \int_{r_1(s)}^{r_2(s)} \frac{\Delta u_I dr_o}{(r-r_o)\sqrt{r_2(s)-r_o}} -$$

$$\frac{1 - \frac{dr_2(s)}{ds}}{2\beta\pi\sqrt{r-r_2(s)}} \int_{r_1(s)}^{r_2(s)} \frac{(\beta\Delta u_I - \Delta v_I) dr_o}{\sqrt{r_2(s)-r_o}} \quad (17a)$$

Equation (17a) is the desired expression for the lift distribution in region II in terms of quantities in region I.

Consider Δu_{II} to consist of two components, $\Delta u_{II}'$ and $\Delta u_{II}''$, where $\Delta u_{II}'$ and $\Delta u_{II}''$ are the first and second terms on the right side of equation (17a), respectively. Investigation of the integrals indicates that at $r = r_2(s)$, $\Delta u_{II}' = \Delta u_I$; whereas $\Delta u_{II}''$, in general, has a half-order singularity.

When region II is to the right of region I (fig. 3(b)), the integration for Δu_{II} is conducted along the line $r_o = r$ and may be written as

$$\Delta u_{II} = \frac{\sqrt{s-s_2(r)}}{\pi} \int_{s_1(r)}^{s_2(r)} \frac{\Delta u_I ds_o}{(s-s_o)\sqrt{s_2(r)-s_o}} -$$

$$\frac{1 - \frac{ds_2(r)}{dr}}{2\beta\pi\sqrt{s-s_2(r)}} \int_{s_1(r)}^{s_2(r)} \frac{(\beta\Delta u_I + \Delta v_I) ds_o}{\sqrt{s_2(r)-s_o}} \quad (17b)$$

Discussion of equations (17a) and (17b). - In the paragraph preceding equation (2), the line $r = r_2(s)$ was described as subsonically inclined at all points to the free stream. This condition is necessary so that the inner integral in equation (11a) (that is, $G(r, s_0)$) can be equated to zero for all points in region II. If this restriction on $r = r_2(s)$ is not satisfied, the development beyond equation (11a) becomes invalid. The derivation of cancellation equations when $r = r_2(s)$ is supersonic was not undertaken because such problems can be solved more simply by other methods.

In regard to the boundary conditions, it has been assumed that Δu_I is specified. Equations (17a) and (17b), however, indicate that a knowledge of Δv_I is also required in order to obtain a solution for Δu_{II} . Two possibilities exist, as illustrated in figure 4. In the first case (fig. 4(a)), region I is upstream of region II (along the line $r = r_2(s)$) and Δv_I is uniquely defined by the specified Δu_I according to the relation

$$\Delta v_I = \frac{\partial}{\partial y} \int_{x_1(y)}^x \Delta u_I dx_0 \quad (18a)$$

The integration is conducted along lines of constant y . In the second case (fig. 4(b)), region II is upstream of region I (along the line $r = r_2(s)$) and the expression for Δv_I in region I (for $y \leq 0$) is

$$\Delta v_I = \frac{\partial}{\partial y} \left[\int_{-\beta y}^{x_2(y)} \Delta u_{II} dx_0 + \int_{x_2(y)}^x \Delta u_I dx_0 \right] \quad (18b)$$

Equation (18b) indicates that a knowledge of Δu_{II} is required in order to find Δv_I . But Δv_I must be known (equation (17a)) before Δu_{II} can be found. Thus, the solution for Δu_{II} from a specified Δu_I is not unique for the configuration of figure 4(b) and an additional boundary condition must be imposed. The line $r = r_2(s)$, however, corresponds to a plan-form edge of the airfoil whose load

distribution is desired. The situation indicated in figure 4(b) occurs when $r = r_2(s)$ corresponds to a subsonic trailing edge. The additional condition to be imposed is therefore the Kutta condition. In terms of the cancellation wing, this condition requires that the perturbation velocities be continuous in crossing $r = r_2(s)$.

Solution for Δu_{II} satisfying Kutta condition at $r = r_2(s)$. -

It will now be shown that when the Kutta condition is imposed at $r = r_2(s)$, the appropriate Δv_I distribution is such as to make the second integral in equation (17a) identically zero; that is,

$$\int_{r_1(s)}^{r_2(s)} \frac{\beta \Delta u_I - \Delta v_I}{[r_2(s) - r_o]^{1/2}} dr_o = 0$$

or, inasmuch as $\beta \Delta u_I - \Delta v_I = M \frac{\partial \Delta \phi_I}{\partial r_o}$,

$$\int_{r_1(s)}^{r_2(s)} \frac{\frac{\partial \Delta \phi_I}{\partial r_o} dr_o}{[r_2(s) - r_o]^{1/2}} = 0$$

This concept and its proof follow from a suggestion of H. S. Ribner of the NACA Lewis laboratory.

Thus, from equation (7), (12), and (13),

$$\int_{r_1(s)}^r \frac{\frac{\partial \Delta \phi}{\partial r_o} dr_o}{(r - r_o)^{1/2}} = 0 \quad (19)$$

for all points (r, s) in region II. Therefore,

$$\int_{r_1(s)}^{r_2(s)} \frac{\frac{\partial \Delta \phi_I}{\partial r_o} dr_o}{(r - r_o)^{1/2}} = - \int_{r_2(s)}^r \frac{\frac{\partial \Delta \phi_{II}}{\partial r_o} dr_o}{(r - r_o)^{1/2}} \quad (20)$$

Upon taking the limit as r approaches $r_2(s)$, equation (20) becomes

$$\int_{r_1(s)}^{r_2(s)} \frac{\frac{\partial \Delta \varphi_I}{\partial r_o} dr_o}{[r_2(s) - r_o]^{1/2}} = \lim_{r \rightarrow r_2(s)} \left[- \int_{r_2(s)}^r \frac{\frac{\partial \Delta \varphi_{II}}{\partial r_o} dr_o}{(r - r_o)^{1/2}} \right] \quad (21)$$

However, $\partial \Delta \varphi_I / \partial r_o$ must be continuous in the vicinity of $r_2(s)$. (The perturbation velocities on the basic wing can be discontinuous only along Mach lines or along plan-form edges. Inasmuch as $r = r_2(s)$ is neither of these cases, all derivatives of $\Delta \varphi_I$ must be continuous in the vicinity of $r = r_2(s)$.) When the Kutta condition is imposed, $\partial \Delta \varphi_{II} / \partial r_o$ is therefore also continuous (and bounded) in the neighborhood of $r = r_2(s)$. Then, using a mean value for $\partial \Delta \varphi_{II} / \partial r_o$,

$$\begin{aligned} & \lim_{r \rightarrow r_2(s)} \left[\int_{r_2(s)}^r \frac{\frac{\partial \Delta \varphi_{II}}{\partial r_o} dr_o}{(r - r_o)^{1/2}} \right] \\ &= \lim_{r \rightarrow r_2(s)} \left[\left(\frac{\partial \Delta \varphi_{II}}{\partial r_o} \right)_{(r_2(s) < r_o < r)} \int_{r_2(s)}^r \frac{dr_o}{(r - r_o)^{1/2}} \right] \\ &= 0 \end{aligned} \quad (22)$$

Therefore

$$\int_{r_1(s)}^{r_2(s)} \frac{\frac{\partial \Delta \varphi_I}{\partial r_o} dr_o}{[r_2(s) - r_o]^{1/2}} = 0 \quad (23)$$

which was to be proved.

1297

The solution for Δu_{II} that satisfies the Kutta condition at $r = r_2(s)$ is then, from equations (17a) and (23),

$$\Delta u_{II} = \frac{\sqrt{r-r_2(s)}}{\pi} \int_{r_1(s)}^{r_2(s)} \frac{\Delta u_I dr_o}{(r-r_o)\sqrt{r_2(s)-r_o}} \quad (24a)$$

for the wing of figure 3(a). Similarly,

$$\Delta u_{II} = \frac{\sqrt{s-s_2(r)}}{\pi} \int_{s_1(r)}^{s_2(r)} \frac{\Delta u_I ds_o}{(s-s_o)\sqrt{s_2(r)-s_o}} \quad (24b)$$

for the wing of figure 3(b).

An alternate derivation of equations (24a) and (24b) (appendix D) indicates that only solutions satisfying the Kutta condition will result from the integral equation formulations of reference 5.

Sidewash in region II. - An expression for Δv_{II} can be obtained by differentiating equation (15) with respect to y . The result is

$$\Delta v_{II} = \frac{\sqrt{r-r_2(s)}}{\pi} \int_{r_1(s)}^{r_2(s)} \frac{\Delta v_I dr_o}{(r-r_o)\sqrt{r_2(s)-r_o}} + \frac{1 + \frac{dr_2(s)}{ds}}{2\pi\sqrt{r-r_2(s)}} \int_{r_1(s)}^{r_2(s)} \frac{\beta\Delta u_I - \Delta v_I}{\sqrt{r_2(s)-r_o}} dr_o$$

Similarly, for region II to the right of region I,

$$\Delta v_{II} = \frac{\sqrt{s-s_2(r)}}{\pi} \int_{s_1(r)}^{s_2(r)} \frac{\Delta v_I ds_0}{(s-s_0)\sqrt{s_2(r)-s_0}} +$$

$$\frac{1 + \frac{ds_2(r)}{ds}}{2\pi\sqrt{s-s_2(r)}} \int_{s_1(r)}^{s_2(r)} \frac{\beta\Delta u_I + \Delta v_I}{\sqrt{s_2(r)-s_0}} ds_0$$

When the Kutta condition applies, these equations become, respectively,

$$\Delta v_{II} = \frac{\sqrt{r-r_2(s)}}{\pi} \int_{r_1(s)}^{r_2(s)} \frac{\Delta v_I dr_0}{(r-r_0)\sqrt{r_2(s)-r_0}}$$

and

$$\Delta v_{II} = \frac{\sqrt{s-s_2(r)}}{\pi} \int_{s_1(r)}^{s_2(r)} \frac{\Delta v_I ds_0}{(s-s_0)\sqrt{s_2(r)-s_0}}$$

It should be noted that when $r = r_2(s)$ corresponds to a subsonic trailing edge, Δv_I , as well as Δv_{II} , is not generally known. The preceding expressions are therefore primarily useful for those problems where $r = r_2(s)$ corresponds to a subsonic leading edge.

APPLICATIONS

The loading in region II of a cancellation wing is given by the line integrals of equation (17a) or (17b). When the Kutta condition is imposed at a subsonic trailing edge, the expressions reduce to equations (24a) and (24b). These equations can be used to find the load distribution on a large variety of wings that cannot be solved by cancellation techniques based on conical

superposition. Wings with curvilinear plan forms or arbitrary camber are examples. In each case, however, the solution for the related wing must be known.

The equations are applied in several illustrative examples. Only the solution associated with the cancellation wing is considered. The complete solution consists in the loading of the related wing minus the loading of the cancellation wing.

Leading-Edge and Side-Edge Cancellations

In these cases, the lift to be canceled is upstream or to the side of the plan form for which the loading is desired (figs. 5 and 6).

Tip region of swept wing. - The loading in the region influenced by the side edge (II_a and II_b of fig. 5) of a swept wing having a subsonic leading and a supersonic trailing edge can be obtained by canceling excess lift on a triangular wing. The Kutta condition is applied across the portion of $r = r_2(s)$ influencing region II_b . The lift to be canceled in region I is (reference 13, equation (23))

$$\Delta u_I = \frac{H\theta^2 x}{\sqrt{\theta^2 x^2 - \beta^2 y^2}} = \frac{H\theta^2 (s+r)}{\sqrt{\theta^2 (s+r)^2 - (s-r)^2}} \quad (25)$$

where H and θ are constants defined in appendix A. The doublet distribution in region I_a , again from reference 13, is

$$\Delta\phi_{I_a} = H\sqrt{\theta^2 x^2 - \beta^2 y^2} = \frac{\beta H}{M}\sqrt{\theta^2 (s+r)^2 - (s-r)^2}$$

from which

$$\Delta v_{I_a} = \frac{\partial \Delta\phi_{I_a}}{\partial y} = \frac{-\beta H^2 y}{\sqrt{\theta^2 x^2 - \beta^2 y^2}} = \frac{-\beta H (s-r)}{\sqrt{\theta^2 (s+r)^2 - (s-r)^2}} \quad (26)$$

The sidewash distribution in region I_b (that is, Δv_{I_b}) could be found by an integration of the type indicated in equation (18b). A knowledge of Δv_{I_b} , however, is unnecessary in the present problem because the Kutta condition is applied for region II_b .

The loading in region II_a is obtained by substituting equations (25) and (26), with r replaced by r_0 , into equation (17a), which yields

$$\Delta u_{II_a} = \frac{H\theta^2 \sqrt{r-r_2(s)}}{\pi} \int_{r_1(s)}^{r_2(s)} \frac{(s+r_0) dr_0}{(r-r_0) \sqrt{r_2(s)-r_0} \sqrt{\theta^2(s+r_0)^2 - (s-r_0)^2}}$$

$$\frac{H \left[1 - \frac{dr_2(s)}{ds} \right]}{2\pi \sqrt{r-r_2(s)}} \int_{r_1(s)}^{r_2(s)} \frac{[\theta^2(s+r_0) + (s-r_0)] dr_0}{\sqrt{r_2(s)-r_0} \sqrt{\theta^2(s+r_0)^2 - (s-r_0)^2}} \quad (27)$$

For region II_b, the Kutta condition applies and

$$\Delta u_{II_b} = \frac{H\theta^2 \sqrt{r-r_2(s)}}{\pi} \int_{r_1(s)}^{r_2(s)} \frac{(s+r_0) dr_0}{(r-r_0) \sqrt{r_2(s)-r_0} \sqrt{\theta^2(s+r_0)^2 - (s-r_0)^2}} \quad (28)$$

Equations (27) and (28) reduce to elliptic integrals of the first, second, and third kind upon transforming the variable of integration from r_0 to ω_0 according to the relation

$$r_0 = \frac{1}{1+\theta} \left[(1-\theta)s + a_2 \omega_0^2 \right] \quad (29)$$

where

$$a_2 = (1+\theta)r_2(s) - (1-\theta)s$$

Equations (27) and (28) may then be written

$$\Delta u_{IIa} = \frac{H\theta^2 \sqrt{r-r_2(s)}}{\pi \sqrt{s\theta}} \left\{ \frac{(s+r)(1+\theta)}{a} \left[\Pi\left(\frac{\pi}{2}, n, k\right) - \Pi(\phi, n, k) \right] - \left[F\left(\frac{\pi}{2}, k\right) - F(\phi, k) \right] \right\} - \frac{H \sqrt{s\theta} \left[1 - \frac{dr_2(s)}{ds} \right]}{\pi \sqrt{r-r_2(s)}} \left\{ 2 \left[E\left(\frac{\pi}{2}, k\right) - E(\phi, k) \right] - \left[F\left(\frac{\pi}{2}, k\right) - F(\phi, k) \right] \right\} \quad (30)$$

and

$$\Delta u_{IIb} = \frac{H\theta^2 \sqrt{r-r_2(s)}}{\pi \sqrt{s\theta}} \left\{ \frac{(s+r)(1+\theta)}{a} \left[\Pi\left(\frac{\pi}{2}, n, k\right) - \Pi(\phi, n, k) \right] - \left[F\left(\frac{\pi}{2}, k\right) - F(\phi, k) \right] \right\} \quad (31)$$

where

$$k = \sqrt{\frac{1-\theta}{4s\theta}} a_2 \quad a = (1+\theta) r - (1-\theta)s$$

$$\phi = \sin^{-1} \sqrt{\frac{a_1}{a_2}} \quad a_1 = (1+\theta) r_1(s) - (1-\theta)s$$

$$n = -\frac{a_2}{a} \quad a_2 = (1+\theta) r_2(s) - (1-\theta)s$$

Reentrant side edge. - A plan form has a reentrant edge if a line of constant y intersects the plan form at more than two points.

The load distribution in the region influenced by the reentrant side edge is to be determined for the wing of figure 6. The side

edge is first, for simplicity, the straight line $r = K_2s$, which is a subsonic trailing edge across which the Kutta condition is applied. The side edge then alternately becomes a subsonic leading and a subsonic trailing edge. The load distribution in region I is simply the Ackeret value $\Delta u_I = \frac{2\alpha U}{\beta}$, and $\Delta v_{I_a} = 0$. Regions II_a, II_b, and II_c are considered separately.

Region II_a.

From equation (24a) with $\Delta u_I = \frac{2\alpha U}{\beta}$

$$\begin{aligned} \Delta u_{II_a} &= \frac{\sqrt{r-K_2s}}{\pi} \int_{-s}^{K_2s} \frac{2\alpha U dr_o}{\beta(r-r_o)\sqrt{K_2s-r_o}} \\ &= \frac{4\alpha U}{\beta\pi} \tan^{-1} \sqrt{\frac{(K_2+1)s}{r-K_2s}} \end{aligned} \quad (32a)$$

or, in x,y-coordinates

$$\Delta u_{II_a} = \frac{4\alpha U}{\beta\pi} \tan^{-1} \sqrt{\frac{x+\beta y}{\beta(m_2x-y)}} \quad (32b)$$

Region II_b.

A knowledge of Δv_{I_b} is required. From equation (18b),

$$\begin{aligned} \Delta v_{I_b} &= \frac{\partial}{\partial y} \left[\frac{4\alpha U}{\beta\pi} \int_{-\beta y}^{y/m_2} \tan^{-1} \sqrt{\frac{x_o+\beta y}{\beta(m_2x_o-y)}} dx_o + \frac{2\alpha U}{\beta} \int_{y/m_2}^x dx_o \right] \\ &= \frac{2\alpha U}{\sqrt{|\beta m_2|}} = 2\alpha U \sqrt{\frac{K_2+1}{K_2-1}} \end{aligned} \quad (33)$$

The load distribution in region II_b is then, recalling that $\Delta v_{I_a} = 0$,

$$\begin{aligned} \Delta u_{II_b} &= \frac{\sqrt{r-r_2(s)}}{\pi} \int_{-s}^{r_2(s)} \frac{2\alpha U dr_0}{\beta(r-r_0) \sqrt{r_2(s)-r_0}} - \\ & \left[\frac{1 - \frac{dr_2(s)}{ds}}{2\beta\pi \sqrt{r-r_2(s)}} \int_{-s}^s \frac{2\alpha U dr_0}{\sqrt{r_2(s)-r_0}} + \int_{-s}^{r_2(s)} \left(2\alpha U - 2\alpha U \sqrt{\frac{K_2+1}{K_2-1}} \frac{dr_0}{\sqrt{r_2(s)-r_0}} \right) \right] \\ &= \frac{2\alpha U}{\beta\pi} \left(2 \tan^{-1} \sqrt{\frac{r_2(s)+s}{r-r_2(s)}} - \frac{1 - \frac{dr_2(s)}{ds}}{\sqrt{r-r_2(s)}} \left\{ \sqrt{r_2(s)+s} - \sqrt{\left(\frac{K_2+1}{K_2-1}\right) [r_2(s)-s]} \right\} \right) \end{aligned} \quad (34)$$

Region II_c.

Because the Kutta condition is applied,

$$\Delta u_{II_c} = \frac{4\alpha U}{\beta\pi} \tan^{-1} \sqrt{\frac{r_2(s)+s}{r-r_2(s)}} \quad (35)$$

Trailing-Edge Cancellation

The calculation of lift distributions on swept wings having subsonic trailing edges requires cancellation wings of the type shown in figure 7. These wings cancel that part of the lift of the basic triangular wing that is downstream of the trailing edge of the swept wing (references 3, 4, 6, and 7). The lift is specified in region I. The lift in regions II and III is to be determined subject to the conditions that $w = 0$ and that the Kutta condition applies at $r = r_1(s)$ and $r = r_2(s)$.

The wing of figure 7(a) differs from the previously discussed cases in that two unknown regions (II and III) are continuously interacting. A special treatment is required in order to obtain the loading in regions II and III. (See, for example, reference 6.) Approximate solutions can be obtained, however, using equations (24a) and (24b). For example, if the load at (r,s) in region II is desired, first assume that Δu_{III} is known. Then

$$\Delta u_{II} = \frac{\sqrt{r-r_2(s)}}{\pi} \left[\int_{\frac{Mc_r}{2\beta}}^{r_1(s)} \frac{\Delta u_{III} dr_0}{(r-r_0)\sqrt{r_2(s)-r_0}} + \int_{r_1(s)}^{r_2(s)} \frac{\Delta u_I dr_0}{(r-r_0)\sqrt{r_2(s)-r_0}} \right] \quad (36)$$

An expression for Δu_{III} is, by integrating along lines of constant r_0 (fig. 7(a)),

$$\Delta u_{III} = \frac{\sqrt{s-s_1(r_0)}}{\pi} \left[\int_{\frac{Mc_r}{2\beta}}^{s_2(r_0)} \frac{\Delta u_{II} ds_0}{(s-s_0)\sqrt{s_1(r_0)-s_0}} + \int_{s_2(r_0)}^{s_1(r_0)} \frac{\Delta u_I ds_0}{(s-s_0)\sqrt{s_1(r_0)-s_0}} \right]$$

An approximate expression for Δu_{III} is then

$$\Delta u_{III} \approx \frac{\sqrt{s-s_1(r_0)}}{\pi} \int_{s_2(r_0)}^{s_1(r_0)} \frac{\Delta u_I ds_0}{(s-s_0)\sqrt{s_1(r_0)-s_0}} \quad (37)$$

Equation (36), which may now be written in terms of Δu_I by substituting equation (37) for Δu_{III} , becomes

$$\Delta u_{II} \approx \left\{ \frac{\sqrt{r-r_2(s)}}{\pi} \int_{r_1(s)}^{r_2(s)} \frac{Mc_T}{2\beta} \frac{dr_0}{(r-r_0)\sqrt{r_2(s)-r_0}} \left[\frac{\sqrt{s-s_1(r_0)}}{\pi} \int_{s_2(r_0)}^{s_1(r_0)} \frac{\Delta u_I ds_0}{(s-s_0)\sqrt{s_1(r_0)-s_0}} \right] + \int_{r_1(s)}^{r_2(s)} \frac{\Delta u_I dr_0}{(r-r_0)\sqrt{r_2(s)-r_0}} \right\} \quad (38)$$

The first term on the right side of equation (38) approximates the contribution of region III to the loading in region II. This term, as indicated in reference 6, is negligible for the commonly encountered Δu_I distributions (corresponding to steady lift, roll, or pitch) and $\frac{L}{\beta dy} \frac{dx}{x} > 0.5$. For those cases, equation (38) simplifies to

$$\Delta u_{II} \approx \frac{\sqrt{r-r_2(s)}}{\pi} \int_{r_1(s)}^{r_2(s)} \frac{\Delta u_I dr_0}{(r-r_0)\sqrt{r_2(s)-r_0}} \quad (39)$$

The Kutta condition at $r = r_2(s)$ is satisfied by both equations (38) and (39). Equation (39) can be reduced to canonical form by the substitution indicated in equation (29).

When region I has a partly supersonic leading edge (fig. 7(b)), it is possible to write exact expressions for the linearized load distribution in regions II and III. For example, the load at point (r,s) of figure 7(b) is

$$\Delta u_{II} = \frac{\sqrt{r-r_2(s)}}{\pi} \left\{ \int_c^{r_1(s)} \frac{dr_0}{(r-r_0)\sqrt{r_2(s)-r_0}} \left[\frac{\sqrt{s-s_1(r_0)}}{\pi} \int_{s_3(r_0)}^{s_1(r_0)} \frac{\Delta u_I ds_0}{(s-s_0)\sqrt{s_1(r_0)-s_0}} \right] + \int_{r_1(s)}^{r_2(s)} \frac{\Delta u_I dr_0}{(r-r_0)\sqrt{r_2(s)-r_0}} \right\} \quad (40)$$

Successive Cancellations

A cancellation wing may induce lift that itself must be canceled in order to satisfy boundary conditions completely. Thus, in figure 8, the cancellation of lift in region I

induces lift in region I'. The cancellation of lift in region I' induces lift in region I'', and so forth. Each of these cancellations is handled as previously described. These computations are very tedious when lift is induced upstream of a subsonic leading edge (for example, region I' of fig. 8), inasmuch as a knowledge of the sidewash (Δv_{T_1}), as well as of the lift distribution (Δu_{T_1}), is needed in order to continue the cancellation process. Numerical methods are generally required.

Successive cancellations are discussed more extensively in references 3 and 4.

SUMMARY OF ANALYSIS AND APPLICATIONS

A general expression was determined for the lift distribution over a cancellation wing. The expression is valid when the plan-form boundary (on cancellation wing) separating the region of zero upwash from the region for which the lift is specified is everywhere subsonically inclined to the free stream. This expression permits the determination of lift distributions on wings that cannot be solved by cancellation techniques based on conical superposition. The boundary conditions for either the flow about a subsonic leading edge or a subsonic trailing edge can be satisfied.

The lift cancellation technique was illustrated for swept wings having curvilinear plan forms. Leading-edge and trailing-edge cancellations were considered. In addition, the loading in a region influenced by a reentrant side edge was found.

Lewis Flight Propulsion Laboratory,
National Advisory Committee for Aeronautics,
Cleveland, Ohio, January 16, 1950.

APPENDIX A

SYMBOLS

The following symbols are used in this report:

a $(1+\theta)r-(1-\theta)s$

a_1 $(1+\theta)r_1(s)-(1-\theta)s$

a_2 $(1+\theta)r_2(s)-(1-\theta)s$

ΔC_p local lift coefficient, $\frac{P_B - P_T}{q}$

c constant

c_r root chord of swept wing

$E(\phi, k)$ elliptic integral of second kind,

$$E(\phi, k) = \int_0^{\sin \phi} \frac{\sqrt{1-k^2 \omega_o^2}}{\sqrt{1-\omega_o^2}} d\omega_o$$

$F(\phi, k)$ elliptic integral of first kind,

$$F(\phi, k) = \int_0^{\sin \phi} \frac{d\omega_o}{\sqrt{(1-\omega_o^2)(1-k^2 \omega_o^2)}}$$

$G(r, s_o)$ function of r and s_o defined by equation (12)

$$H = \frac{2\alpha U}{\beta E\left(\frac{\pi}{2}, \sqrt{1-\theta^2}\right)}$$

K slope of plan-form edge in r, s -coordinates, dr/ds

k modulus of elliptic integrals

M Mach number

m slope of plan-form edge in x,y-coordinates, dy/dx

n parameter of elliptic integral of third kind

p local static pressure

$$q = \frac{1}{2} \rho U^2$$

$\left. \begin{array}{l} r, r_0 \\ s, s_0 \end{array} \right\}$ Mach coordinate system (equation (4))

U free-stream velocity

u,v,w perturbation velocities in x-, y-, and z-directions, respectively

$$\Delta u = u_T - u_B \quad (\text{proportional to local lift})$$

$$\Delta v = v_T - v_B$$

$\left. \begin{array}{l} x, x_0 \\ y, y_0 \\ z, z_0 \end{array} \right\}$ Cartesian coordinate system

α angle of attack

$$\beta = \sqrt{M^2 - 1}$$

δ semivertex angle of triangular wing

$$\theta = \beta \tan \delta$$

$\Pi(\phi, n, k)$ elliptic integral of third kind,

$$\int_0^{\sin \phi} \frac{d\omega_0}{(1+n\omega_0^2) \sqrt{(1-k^2\omega_0^2)(1-\omega_0^2)}}$$

ρ	density
τ	area of integration
ϕ	amplitude of elliptic integrals
φ	perturbation velocity potential
$\Delta\varphi$	doublet strength, $\varphi_T - \varphi_B$
ω_0	integration variable

Regions:

I	region on cancellation wing for which loading is specified
I_a, I_b, \dots	subdivisions of region I
II	region on cancellation wing for which $w = 0$
II_a, II_b, \dots	subdivisions of region II
III	additional region on cancellation wing for which $w = 0$

Special designations:

$r = r_1(s)$	r as function of s along plan-form boundary 1
$s = s_1(r)$	s as function of r along plan-form boundary 1
$y = y_1(x)$	y as function of x along plan-form boundary 1
$x = x_1(y)$	x as function of y along plan-form boundary 1
$r = r_2(s)$	r as function of s along plan-form boundary 2
$s = s_2(r)$	s as function of r along plan-form boundary 2

and so forth.

Subscripts:

- 1,2,3 refers to plan-form boundaries 1, 2, and 3, respectively
- I,II refers to regions I and II, respectively
- B bottom surface of $z = 0$ plane
- T top surface of $z = 0$ plane
- o variable of integration

APPENDIX B

SOLUTION OF INTEGRAL EQUATIONS

Consider the following integral equation (in the notation of the appendix in reference 5), where the function $f(x)$ is assumed known and the function $u(\xi)$ is to be determined:

$$\begin{aligned}
 f(x) &= \int_a^x \frac{u(\xi) d\xi}{(x-\xi)^{3/2}} \\
 &= \int_a^x \frac{[u(\xi)-u(x)] d\xi}{(x-\xi)^{3/2}} - \frac{2u(x)}{(x-a)^{1/2}}
 \end{aligned} \tag{B1}$$

After an integration by parts, equation (B1) may be written

$$-\frac{f(x)}{2} - \frac{u(a)}{(x-a)^{1/2}} = \int_a^x \frac{u'(\xi) d\xi}{(x-\xi)^{1/2}} \tag{B2}$$

Equation (B2) is now an integral equation of the Abel type. The continuous solution for $u(\xi)$ is (reference 14)

$$u(z) = -\frac{1}{2\pi} \int_a^z \frac{f(x) dx}{(z-x)^{1/2}} \tag{B3}$$

evaluated at $z = \xi$. This result is presented in reference 5.

Equation (11b) corresponds to equation (B1) with $u(\xi) = G(r, s_0)$ and $f(x) = 0$. The solution for $G(r, s_0)$, according to equation (B3), is then

$$G(r, s_0) = 0 \tag{13}$$

Equation (14) corresponds to equation (B1) with

$$\xi = r_0 \quad a = r_2(s_0)$$

$$x = r \quad f(x) = - \int_{r_1(s_0)}^{r_2(s_0)} \frac{\Delta\varphi_I dr_0}{(r-r_0)^{3/2}}$$

$$u(\xi) = \Delta\varphi_{II}$$

The solution for $\Delta\varphi_{II}$ according to equation (B3) is then

$$\Delta\varphi_{II} = \frac{1}{2\pi} \int_{r_2(s_0)}^z \frac{dr}{\sqrt{z-r}} \int_{r_1(s_0)}^{r_2(s_0)} \frac{\Delta\varphi_I dr_0}{(r-r_0)^{3/2}} \quad (B4)$$

After reversing the order of integration and integrating,

$$\Delta\varphi_{II} = \frac{\sqrt{z-r_2(s_0)}}{\pi} \int_{r_1(s_0)}^{r_2(s_0)} \frac{\Delta\varphi_I dr_0}{(z-r_0) \sqrt{r_2(s_0)-r_0}} \quad (B5)$$

Equation (B5), evaluated at $z = r$ and $s_0 = s$, yields

$$\Delta\varphi_{II} = \frac{\sqrt{r-r_2(s)}}{\pi} \int_{r_1(s)}^{r_2(s)} \frac{\Delta\varphi_I dr_0}{(r-r_0) \sqrt{r_2(s)-r_0}} \quad (15)$$

The derivation of equation (15) is similar to that for equation (16) of reference 5.

APPENDIX C

DIFFERENTIATION TO OBTAIN Δu_{II}

The differentiation indicated in equation (16)

$$\frac{2\beta}{M} \Delta u_{II} = \left(\frac{\partial}{\partial r} + \frac{\partial}{\partial s} \right) \left[\frac{\sqrt{r-r_2(s)}}{\pi} \int_{r_1(s)}^{r_2(s)} \frac{\Delta\varphi_I dr_o}{(r-r_o)\sqrt{r_2(s)-r_o}} \right] \quad (16)$$

is to be conducted.

First

$$\begin{aligned} \frac{2\beta}{M} \Delta u_{II} &= \frac{1 - \frac{dr_2(s)}{ds}}{2\pi\sqrt{r-r_2(s)}} \int_{r_1(s)}^{r_2(s)} \frac{\Delta\varphi_I dr_o}{(r-r_o)\sqrt{r_2(s)-r_o}} + \\ &\frac{\sqrt{r-r_2(s)}}{\pi} \left(\frac{\partial}{\partial r} + \frac{\partial}{\partial s} \right) \int_{r_1(s)}^{r_2(s)} \frac{\Delta\varphi_I dr_o}{(r-r_o)\sqrt{r_2(s)-r_o}} \quad (C1) \end{aligned}$$

Inasmuch as $\Delta\varphi_I$ is a function of r_o and s ,

$$\frac{\partial}{\partial r} \int_{r_1(s)}^{r_2(s)} \frac{\Delta\varphi_I dr_o}{(r-r_o)\sqrt{r_2(s)-r_o}} = - \int_{r_1(s)}^{r_2(s)} \frac{\Delta\varphi_I dr_o}{(r-r_o)^2 \sqrt{r_2(s)-r_o}} \quad (C2a)$$

1297

and

$$\frac{\partial}{\partial s} \int_{r_1(s)}^{r_2(s)} \frac{\Delta\varphi_I dr_o}{(r-r_o)\sqrt{r_2(s)-r_o}} = \int_{r_1(s)}^{r_2(s)} \frac{\left(\frac{\partial\Delta\varphi_I}{\partial s}\right) dr_o}{(r-r_o)\sqrt{r_2(s)-r_o}} +$$

$$\lim_{r_o \rightarrow r_2(s)} \left\{ -\frac{1}{2} \frac{dr_2(s)}{ds} \int_{r_1(s)}^{r_o} \frac{\Delta\varphi_I dr_o}{(r-r_o)[r_2(s)-r_o]^{3/2}} + \right.$$

$$\left. \frac{(\Delta\varphi_I)_{r_o=r_2(s)} dr_2(s)}{(r-r_o)\sqrt{r_2(s)-r_o} ds} \right\} - \frac{(\Delta\varphi_I)_{r_o=r_1(s)} dr_1(s)}{[r-r_1(s)]\sqrt{r_2(s)-r_1(s)} ds}$$

(C2b)

However, $(\Delta\varphi_I)_{r_o=r_1(s)} = 0$ and, by integration by parts,

$$\int_{r_1(s)}^{r_2(s)} \frac{\Delta\varphi_I dr_o}{(r-r_o)[r_2(s)-r_o]^{3/2}} = -2 \int_{r_1(s)}^{r_2(s)} \frac{\left[\frac{\partial\Delta\varphi_I}{\partial r_o} + \frac{\Delta\varphi_I}{(r-r_o)} \right] dr_o}{(r-r_o)\sqrt{r_2(s)-r_o}} +$$

$$\lim_{r_o \rightarrow r_2(s)} \left\{ \frac{2\Delta\varphi_I}{(r-r_o)\sqrt{r_2(s)-r_o}} \right\}_{r_1(s)}^{r_o}$$

so that equation (C2b) can be written as

$$\frac{\partial}{\partial s} \int_{r_1(s)}^{r_2(s)} \frac{\Delta\varphi_I dr_o}{(r-r_o)\sqrt{r_2(s)-r_o}} = \int_{r_1(s)}^{r_2(s)} \frac{\frac{\partial\Delta\varphi_I}{\partial s} dr_o}{(r-r_o)\sqrt{r_2(s)-r_o}} +$$

$$\frac{dr_2(s)}{ds} \int_{r_1(s)}^{r_2(s)} \frac{\left[\frac{\partial\Delta\varphi_I}{\partial r_o} + \frac{\Delta\varphi_I}{(r-r_o)} \right] dr_o}{(r-r_o)\sqrt{r_2(s)-r_o}} \quad (C3)$$

Upon substituting equations (C2a) and (C3) into equation (C1) and integrating by parts those integrals containing $\Delta\varphi_I$, equation (C1) finally reduces to

$$\Delta u_{II} = \frac{\sqrt{r-r_2(s)}}{\pi} \int_{r_1(s)}^{r_2(s)} \frac{\Delta u_I dr_o}{(r-r_o)\sqrt{r_2(s)-r_o}} -$$

$$\frac{1 - \frac{dr_2(s)}{ds}}{2\beta\pi\sqrt{r-r_2(s)}} \int_{r_1(s)}^{r_2(s)} \frac{(\beta\Delta u_I - \Delta v_I) dr_o}{\sqrt{r_2(s)-r_o}} \quad (17a)$$

APPENDIX D

ALTERNATE DERIVATION OF SOLUTION SATISFYING

KUTTA CONDITION AT $r = r_2(s)$

The integral equation formulation in terms of $\Delta\phi$ (equation (14)) resulted in a solution that was continuous in $\Delta\phi$ (equation (15)) but discontinuous, in general, in the derivative $\frac{\partial\Delta\phi}{\partial x} = \Delta u$ (equation (17a)) at $r = r_2(s)$. In order to obtain a solution continuous in Δu , an integral equation may be formulated that is similar to equation (14), but in terms of Δu rather than $\Delta\phi$. The inversion shown in appendix B should result in a solution that is continuous in Δu but discontinuous in the derivatives of Δu at $r = r_2(s)$.

Consider equation (10) for the w distribution in the $z = 0$ plane. This equation will be differentiated with respect to x using a technique introduced in reference 15 (equations (1) to (3)). The expression for w at any point (r,s) is, from equation (10),

$$w = -\frac{M}{8\pi} \iint_{\tau} \frac{\Delta\phi \, dr_o \, ds_o}{(s-s_o)^{3/2} (r-r_o)^{3/2}} \quad (D1)$$

where τ is the area abc in figure 9(a). The wing is moved upstream a distance dx (fig. 9(b)), keeping the coordinate system fixed in space. The expression for the upwash at (r,s) now becomes

$$w + \frac{\partial w}{\partial x} dx = -\frac{M}{8\pi} \left[\iint_{\tau} \frac{\left(\Delta\phi + \frac{\partial\Delta\phi}{\partial x_o} dx \right) dr_o \, ds_o}{(s-s_o)^{3/2} (r-r_o)^{3/2}} + \iint_{\Delta\tau} \frac{\Delta\phi \, dr_o \, ds_o}{(s-s_o)^{3/2} (r-r_o)^{3/2}} \right] \quad (D2)$$

The second term on the right side of equation (D2) is zero because $\Delta\Phi = 0$ along the leading edge. Subtraction of equation (D1) from equation (D2) then yields

$$\frac{\partial w}{\partial x} = -\frac{M}{8\pi} \left[\iint_{\Gamma} \frac{\Delta u \, dr_o \, ds_o}{(s-s_o)^{3/2} (r-r_o)^{3/2}} \right] \quad (D3)$$

For points in region II of a cancellation wing, $\frac{\partial w}{\partial x} = 0$. Thus, for the wing of figure 3(a),

$$0 = \left[\int_0^s \frac{ds_o}{(s-s_o)^{3/2}} \int_{r_1(s_o)}^r \frac{\Delta u \, dr_o}{(r-r_o)^{3/2}} \right] \quad (D4)$$

This equation is the same as equation (11a) except that Δu replaces $\Delta\Phi$. The inversion by Abel's integral equation, for Δu_{II} in terms of Δu_I then gives (from equation (15))

$$\Delta u_{II} = \frac{\sqrt{r-r_2(s)}}{\pi} \int_{r_1(s)}^{r_2(s)} \frac{\Delta u_I \, dr_o}{(r-r_o) \sqrt{r_2(s)-r_o}} \quad (24a)$$

Inasmuch as the integral equations of reference 5 are formulated in terms of Δu and are inverted by means of Abel's integral equation, only solutions satisfying the Kutta condition will result therein.

REFERENCES

1. Lagerstrom, Paco A.: Linearized Supersonic Theory of Conical Wings. NACA TN 1685, 1948.
2. Coleman, T. F.: Supersonic Lift Solutions Obtained by Extending the Simple Linearized Conical Flow Theory. Rep. No. CM-440, North American Aviation, Inc., Feb. 20, 1948. (Bumblebee Proj. Contract NOrd 9784.)
3. Cohen, Doris: The Theoretical Lift of Flat Swept-Back Wings at Supersonic Speeds. NACA TN 1555, 1948.

4. Cohen, Doris: Theoretical Loading at Supersonic Speeds of Flat Swept-Back Wings with Interacting Trailing and Leading Edges. NACA TN 1991, 1949.
5. Goodman, Theodore R.: The Lift Distribution on Conical and Nonconical Flow Regions of Thin Finite Wings in a Supersonic Stream. Jour. Aero. Sci., vol. 16, no. 6, June 1949, pp. 365-374.
6. Ribner, Herbert S.: Some Conical and Quasi-Conical Flows in Linearized Supersonic Wing Theory. NACA TN 2147, 1950.
7. Ribner, Herbert S.: On the Effect of Subsonic Trailing Edges on Damping in Roll and Pitch of Thin Sweptback Wings in a Supersonic Stream. NACA TN 2146, 1950.
8. Robinson, A.: On Source and Vortex Distributions in the Linearized Theory of Steady Supersonic Flow. Rep. No. 9, College Aero. (Cranfield), Oct. 1947.
9. Hadamard, Jacques: Lectures on Cauchy's Problem in Linear Partial Differential Equations. Oxford Univ. Press (London), 1923, pp. 133-135.
10. Heaslet, Max. A., and Lomax, Harvard: The Use of Source-Sink and Doublet Distributions Extended to the Solution of Boundary Value Problems in Supersonic Flow. NACA Rep. 900, 1948. (Formerly NACA TN 1515.)
11. Evvard, John C.: Use of Source Distributions for Evaluating Theoretical Aerodynamics of Thin Finite Wings at Supersonic Speeds. NACA Rep. 951, 1950
12. Mirels, Harold, and Haefeli, Rudolph C.: Line-Vortex Theory for Calculation of Supersonic Downwash. NACA TN 1925, 1949.
13. Heaslet, Max A., and Lomax, Harvard: The Calculation of Downwash behind Supersonic Wings with an Application to Triangular Plan Forms. NACA TN 1620, 1948.
14. Whittaker, E. T., and Watson, G. N.: Modern Analysis. The MacMillan Co. (New York), 1943, p. 229.
15. Evvard, John C.: Theoretical Distribution of Lift on Thin Wings at Supersonic Speeds (An Extension). NACA TN 1585, 1948.

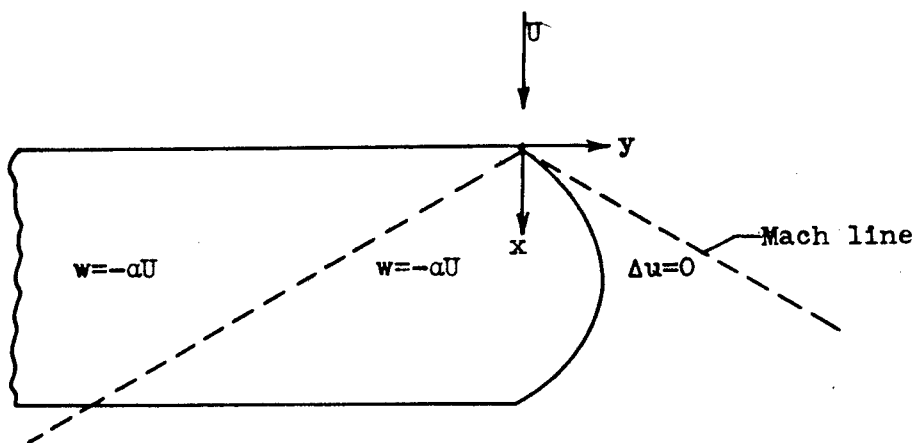

(a) Given wing.

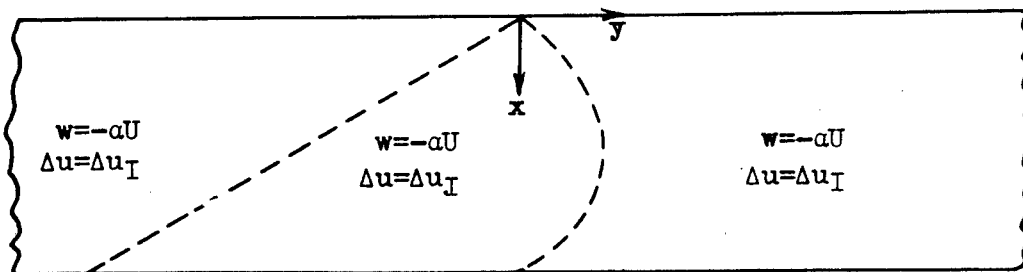

(b) Two-dimensional wing.

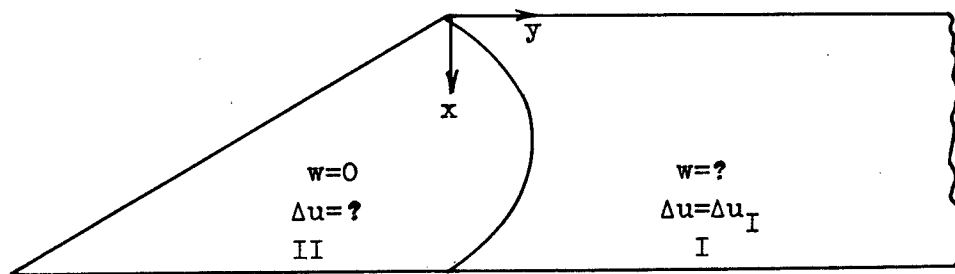

(c) Cancellation wing.



Figure 1. - Superposition to obtain lift on given wing by canceling lift on two-dimensional wing. (Given wing equals two-dimensional wing minus cancellation wing.)

1297

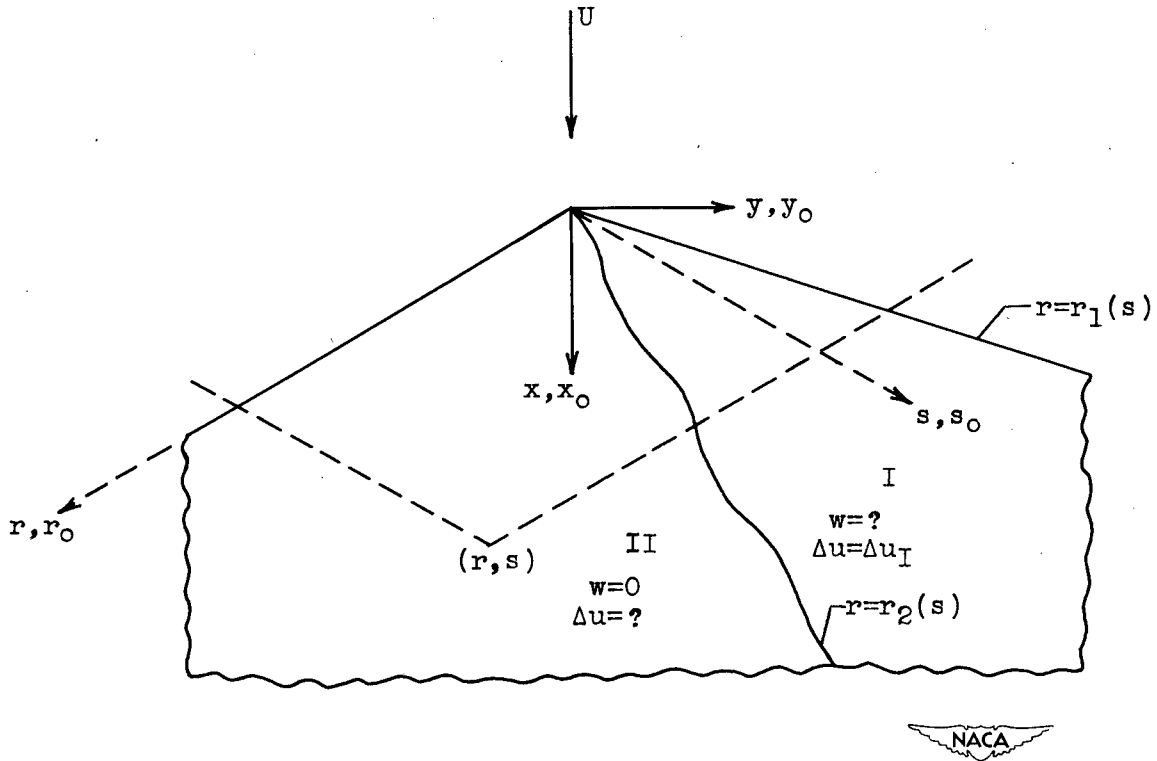
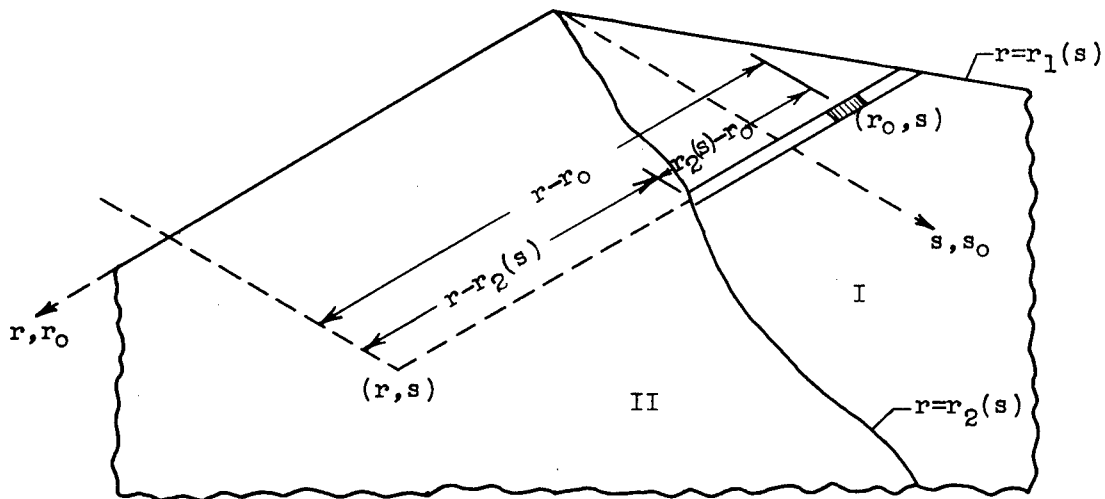
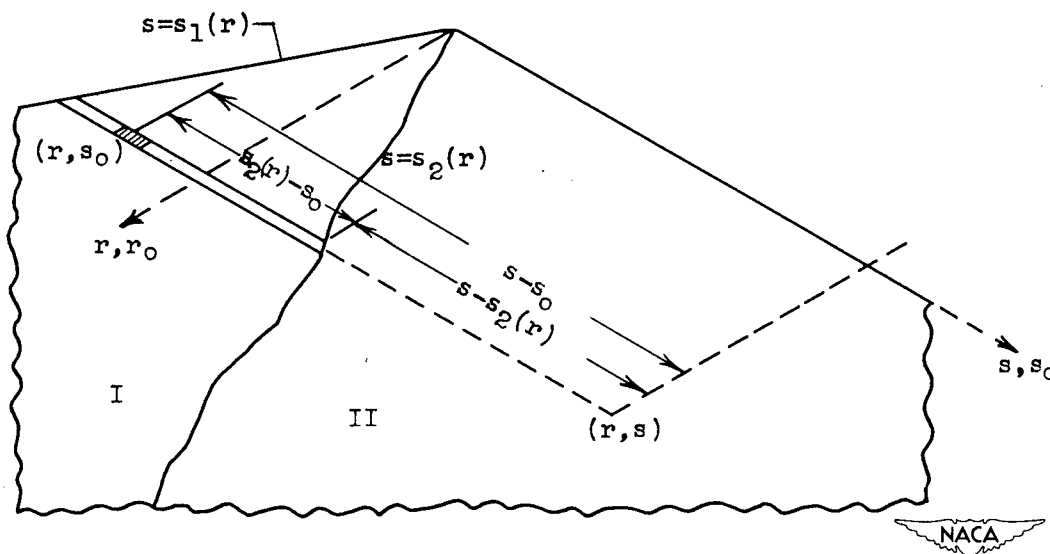

Figure 2. - Typical cancellation wing.



(a) Region I intersected by right forward Mach line from (r, s) .



(b) Region I intersected by left forward Mach line from (r, s) .

Figure 3. - Geometric interpretation of terms in equations (17a) and (17b).

1297

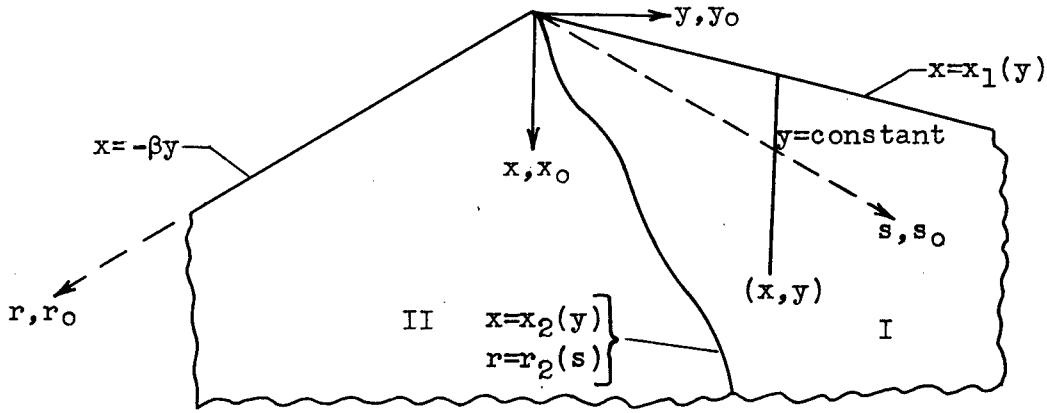

(a) Region I upstream of region II (along $r=r_2(s)$).

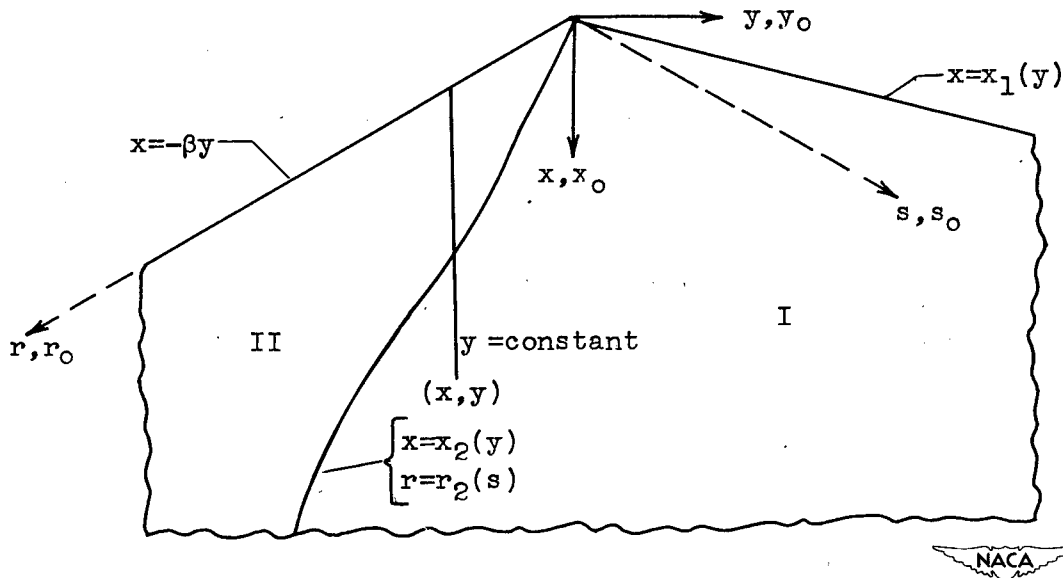

(b) Region II upstream of region I (along $r=r_2(s)$).

Figure 4. - Possible relations between regions I and II in regard to determination of Δv_I .

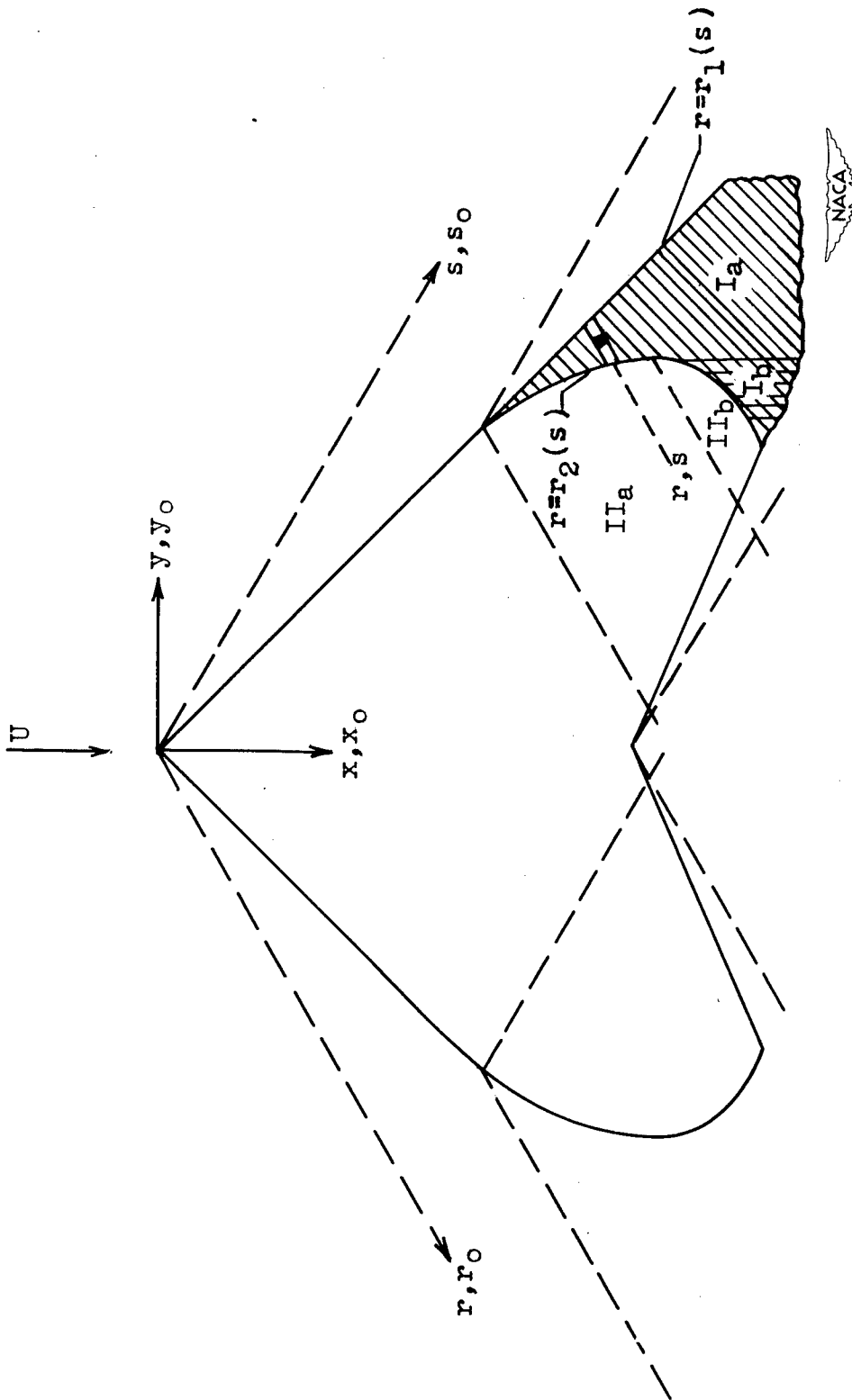

Figure 5. - Cancellation for obtaining loading in tip region of swept wing having supersonic trailing edges.

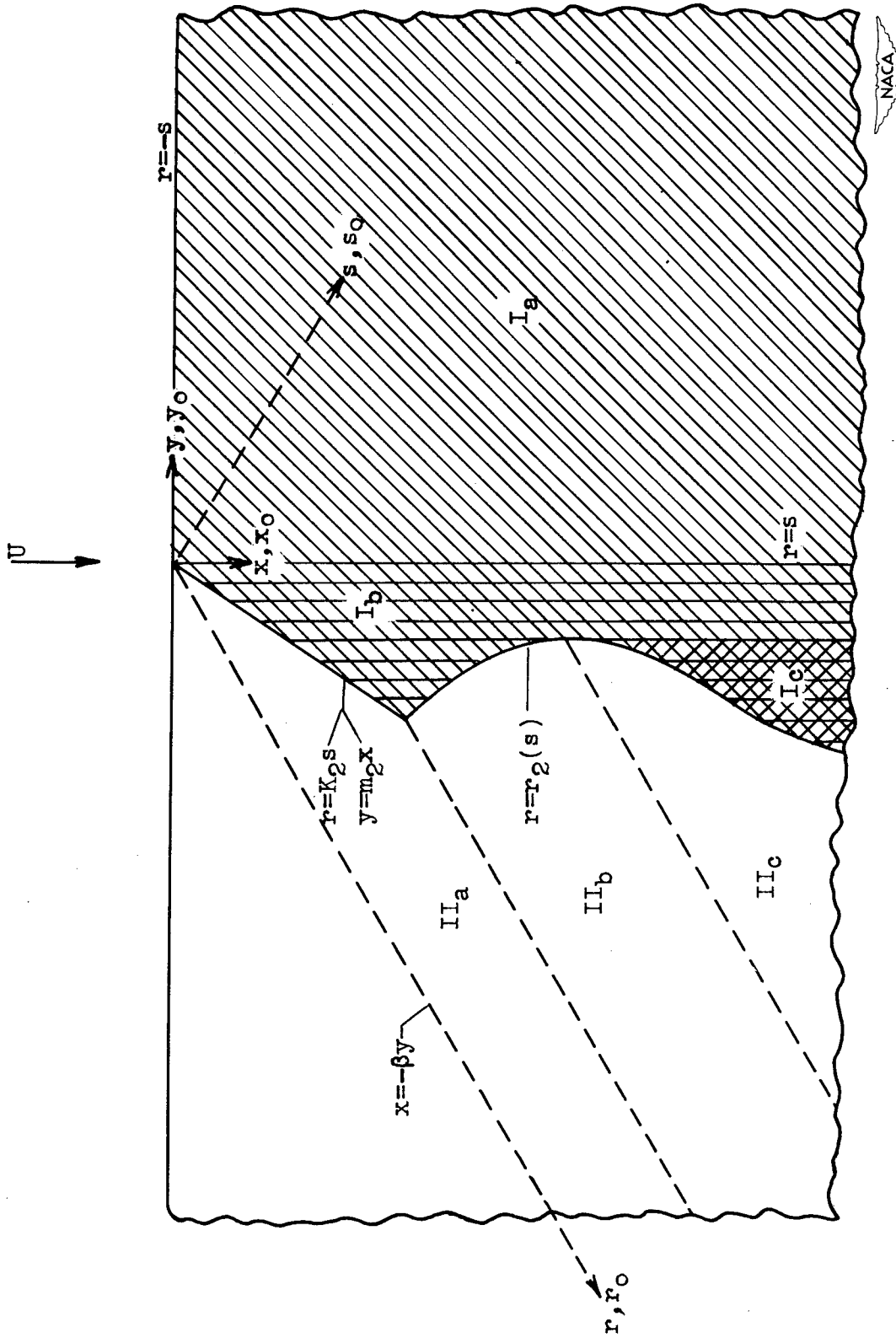
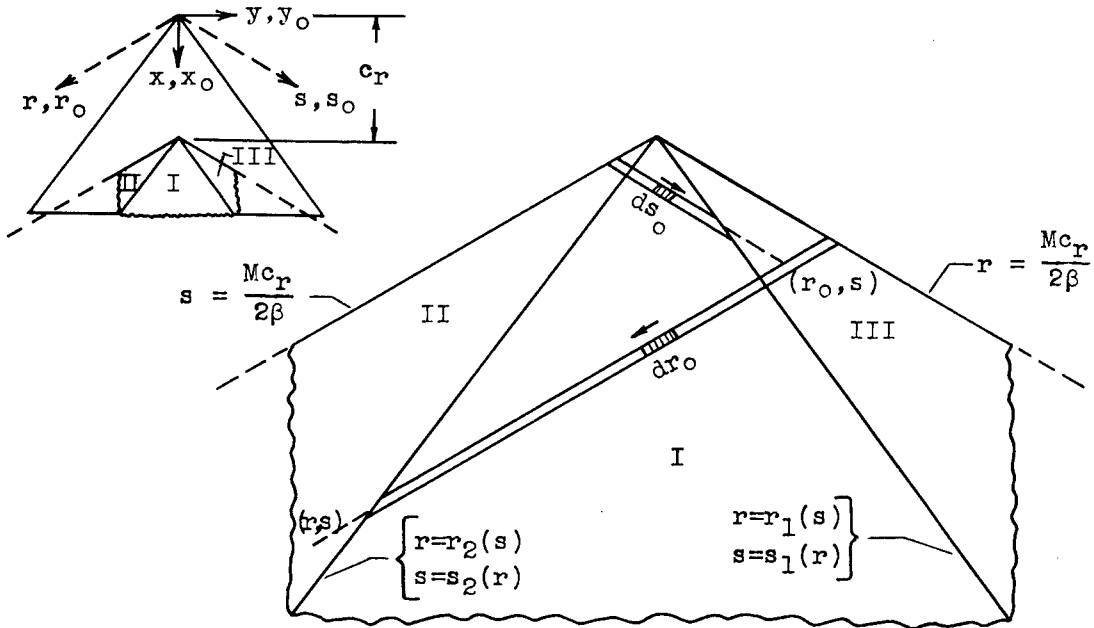
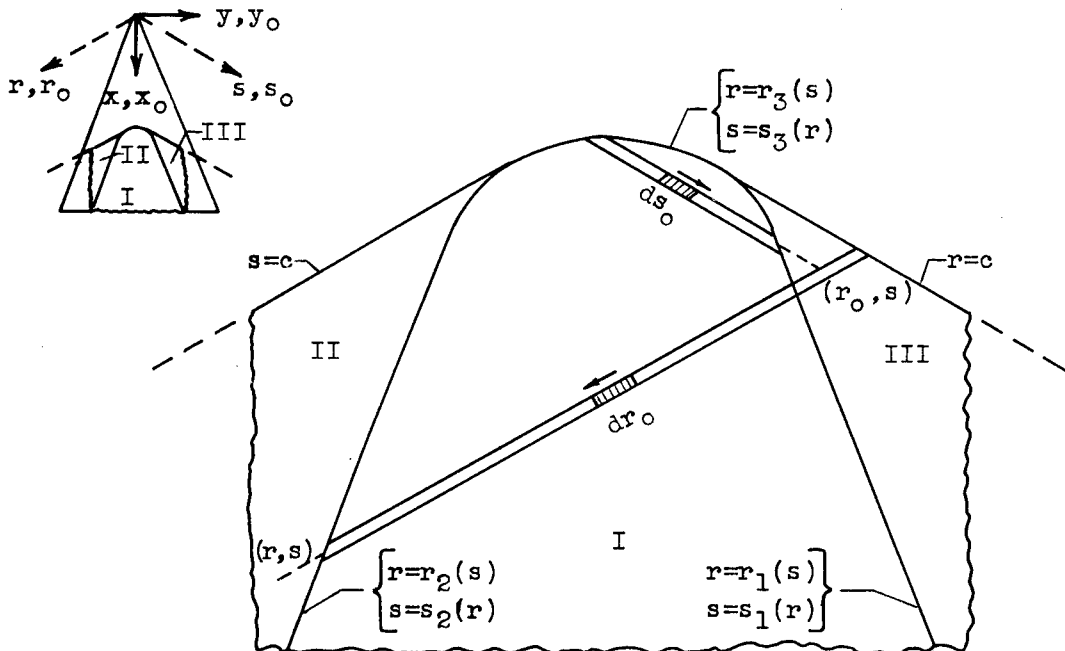

Figure 6. - Cancellation for obtaining loading in region influenced by reentrant side edge.



(a) Regions II and III continuously interacting.



(b) Regions II and III not continuously interacting.

Figure 7. - Typical cancellation wings for canceling lift downstream of subsonic trailing edge of swept wings.

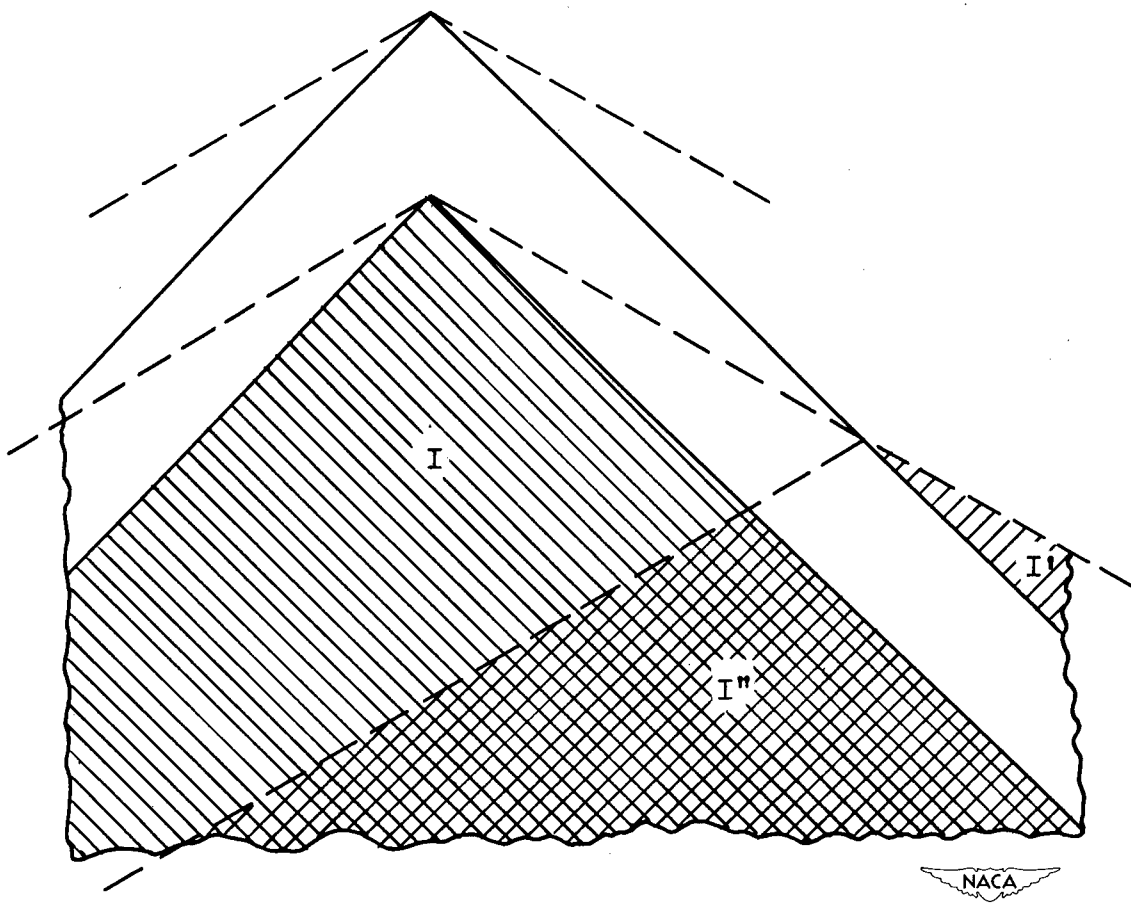
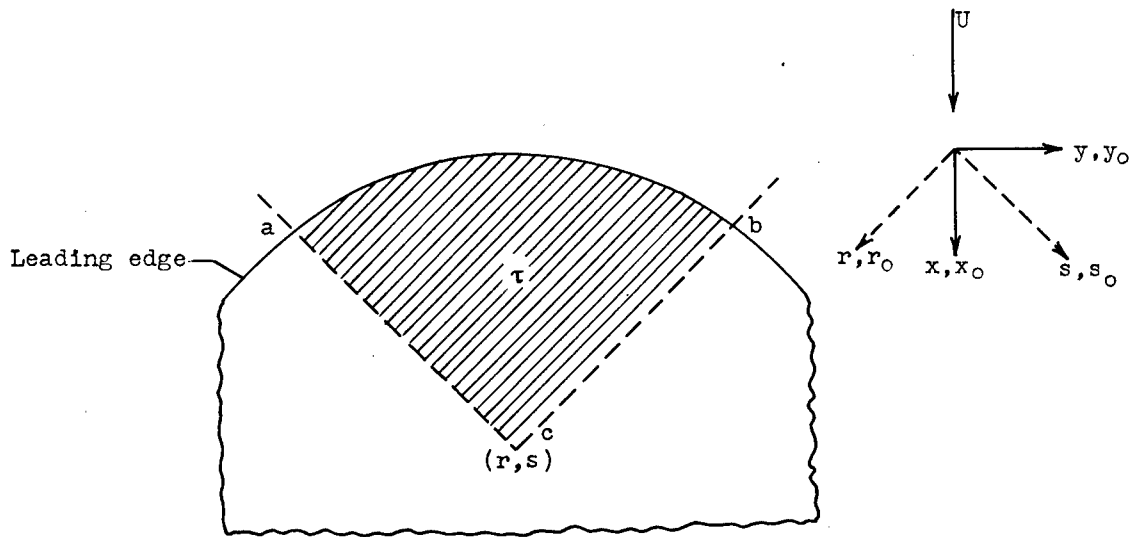
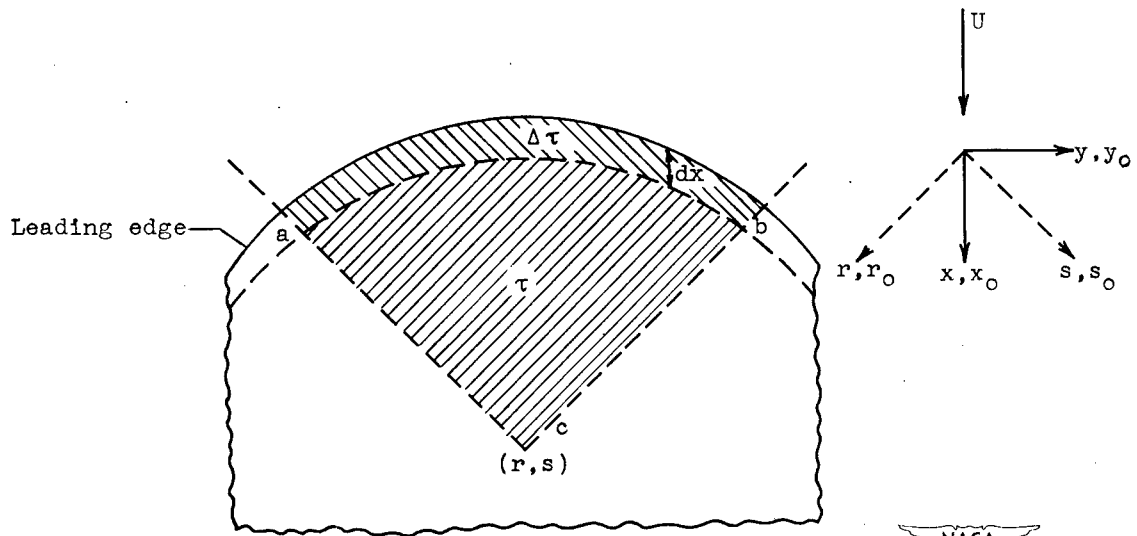

Figure 8. - Successive cancellations.



(a) Original position of wing.



(b) Wing moved upstream distance dx .

Figure 9. - Areas of integration relating to equations (D1) and (D2).

