

ARMY RESEARCH LABORATORY



# Mechanical Design Report for the Main Control Unit of a New Acoustic Sensor Unit

Mark Probst

ARL-MR-467

July 2000

Approved for public release; distribution unlimited.

ARL-MR-467

20000818 145

The findings in this report are not to be construed as an official Department of the Army position unless so designated by other authorized documents.

Citation of manufacturer's or trade names does not constitute an official endorsement or approval of the use thereof.

Destroy this report when it is no longer needed. Do not return it to the originator.

# Army Research Laboratory

Adelphi, MD 20783-1197

---

ARL-MR-467

July 2000

## Mechanical Design Report for the Main Control Unit of a New Acoustic Sensor Unit

Mark Probst

Sensors and Electron Devices Directorate

---

Approved for public release; distribution unlimited.

---

---

---

## Abstract

---

This report documents the mechanical design and fabrication of the main control unit (MCU), one component of the Army Research Laboratory's recent upgrade of its signal-processing field hardware used in data collection and algorithm evaluation. The overall upgrade includes six new acoustic sensor units, each of which has one MCU and two analog signal conditioning boxes (ASCBs). Two appendices provide fabrication and assembly details of the MCU and drawings of the custom-built hardware used to assemble the MCU.

# Contents

<b>1. Introduction</b> .....	<b>1</b>
<b>2. Main Control Unit Mechanical Design Rationale and Description</b> .....	<b>2</b>
<b>2.1 MCU Housing and Housing-Mounted Hardware</b> .....	<b>2</b>
2.1.1 <i>MCU Housing Selection</i> .....	2
2.1.2 <i>MCU Heating and Cooling</i> .....	2
2.1.3 <i>MCU I/O Connector Panels</i> .....	4
<b>2.2 Internal Components and Mounting Hardware</b> .....	<b>5</b>
2.2.1 <i>Floor Plate and Corner Mounting Brackets</i> .....	5
2.2.2 <i>Compact PCI Chassis</i> .....	6
2.2.3 <i>Iomega Jaz Drive</i> .....	9
2.2.4 <i>Precision Lightweight Global Positioning Satellite Receiver</i> .....	11
2.2.5 <i>Packet Radio</i> .....	11
2.2.6 <i>Aironet Series 4500 Wireless LAN Radio</i> .....	11
2.2.7 <i>Dc-to-dc Power Supply/Fuse Panel/Power Distribution Assembly</i> .....	11
<b>Distribution</b> .....	<b>53</b>
<b>Report Documentation Page</b> .....	<b>55</b>

# Appendices

<b>A. MCU Housing Modification and Assembly Notes</b> .....	<b>13</b>
<b>B. MCU Parts Fabrication Drawings</b> .....	<b>23</b>

# Figures

1. Top/front view of MCU; I/O panels in end recesses not visible at this angle .....	3
2. MCU with lid removed and I/O panel, fan, and exhaust doors in operational positions .....	4
3. End view of MCU with lid removed .....	5
4. Looking down into MCU with lid removed .....	6
5. Compact PCI chassis in conventional horizontal orientation .....	7
6. Compact PCI chassis in alternate vertical orientation .....	8
7. Compact PCI chassis after modification/lowering .....	9
8. MCU system components and empty mounting brackets installed on floor plate .....	10
9. MCU system components and empty mounting brackets installed on floor plate .....	10
10. Dc-to-dc power supply/fuse panel/power distribution assembly mount .....	12

# 1. Introduction

The Army Research Laboratory recently upgraded its acoustic signal-processing field hardware used for data collection and algorithm evaluation. The previous hardware system was used to demonstrate remote networked acoustic sensors (RNASs). The upgrade effort consisted of the design and fabrication of six functionally identical sensor units. Each sensor unit has one main control unit (MCU) and two analog signal conditioning boxes (ASCBs), plus the potential to handle from one to eight ASCBs. Each ASCB can receive inputs from one to eight remote sensors. For functional details of and rationale for this upgrade, as well as additional information about the sensor units, MCUs, and ASCBs, see Mays.\* This report describes the mechanical design of the MCU and includes two appendices—the first documents the fabrication and assembly details of the MCU, and the second contains fabrication drawings of all custom-built hardware used to assemble the MCU.

---

\*Mays, B., "Hardware overview for new acoustic sensor" (AMSRL-SE-SA internal memo), 2 February 1999.

## 2. Main Control Unit Mechanical Design Rationale and Description

The MCU functionally and physically consists of two major subassemblies—the housing with housing-mounted hardware (filtered fan and exhaust port assemblies, input/output (I/O) connector panels, and miscellaneous hardware, brackets), and the internal component subassembly comprising a floor plate plus all essential system components and their mounting hardware. With the addition of a few clip leads and interface connectors, the internal component subassembly could perform as a fully assembled MCU if placed in a benign environment. The essential system components of the MCU are a compact peripheral computer interface (PCI) chassis, an Iomega Jaz drive (removable-media SCSI (small computer system interface) device), a Precision Lightweight Global Positioning System Receiver (PLGR), a packet radio, an Aironet wireless LAN (local area network) radio, a dc-to-dc power supply/fuse panel/power distribution assembly, a printed circuit board (PCB) assembly (which provides climate control/emergency shutdown circuitry and breakout connector feeds for the ASCB cables), and various interconnection cables and wiring harnesses.

### 2.1 MCU Housing and Housing-Mounted Hardware

#### 2.1.1 *MCU Housing Selection*

Mechanical design of the MCU proceeded in an unorthodox manner due to a budgetary necessity to commit funds for the main housings before the system was fully defined. The goal was to use a ruggedized shipping case as the MCU housing to facilitate transportation to and from field tests with minimal or no additional packaging. Based upon known sizes for all anticipated components, the design team selected a rotationally molded polyethylene shipping case with 2-in.-thick interior foam lining. In addition to being much cheaper than similarly sized metal or fiberglass shipping cases, the molded polyethylene shipping cases would be easier to modify than metal or fiberglass cases.

#### 2.1.2 *MCU Heating and Cooling*

Since the program was committed to a maximum use of commercial off-the-shelf (COTS) components, we preferred a totally sealed system, especially because dust- and moisture-sensitive disk drives were involved. We could have used either a reversible, solid-state Peltier-effect system or a conventional compressor-based heat pump system for temperature control, but both were too expensive and required too much power (most field test applications of the MCU are in remote areas where battery power is used). Fan cooling and resistance heating (if needed) were the only viable options for the MCU. Given the program's objective

of providing a versatile low-cost test bed system with upgrade capability, we decided that the risk that hot weather operability might be limited was acceptable. If test requirements dictate high-temperature use beyond system limits and shade from direct sunlight does not give adequate improvement, we will need an external cooling source or controlled enclosure.

As figure 1 shows, the case has deep recesses molded into its exterior (one per end and two per side) that are shaped to provide stiffness as well as handgrips for lifting. These exterior recesses were logical sites for I/O connector panels, fans, and exhaust vents (hinged doors could protect them during shipment and the door latches would be adequately protected in the recesses). We chose the two end sites for I/O connector panels and the four side sites for fans and vents; the size of these sites was adequate for standard 4.5-in. muffin fans.

As noted in Mays,\* testing of the first system built showed that one fan would hold the internal MCU temperature to 5 °F above the ambient air outside the container when the system is operating at a nominal dissipation of 60 W. We thus concluded that the addition of a second fan was unwarranted, since it could extend the operating limit by only a few degrees at best. The Jaz disk drive is the limiting MCU component (+50 to +110 °F), and testing showed that a 30-W resistive heater was needed for standby heat if the MCU electronics are shut down during cool weather operation. This report also includes functional details and system operating limits of the complete climate control system (fan, heater, thermostat circuitry, and out-of-range emergency shutdown circuitry).

Figure 1. Top/front view of MCU; I/O panels in end recesses not visible at this angle.

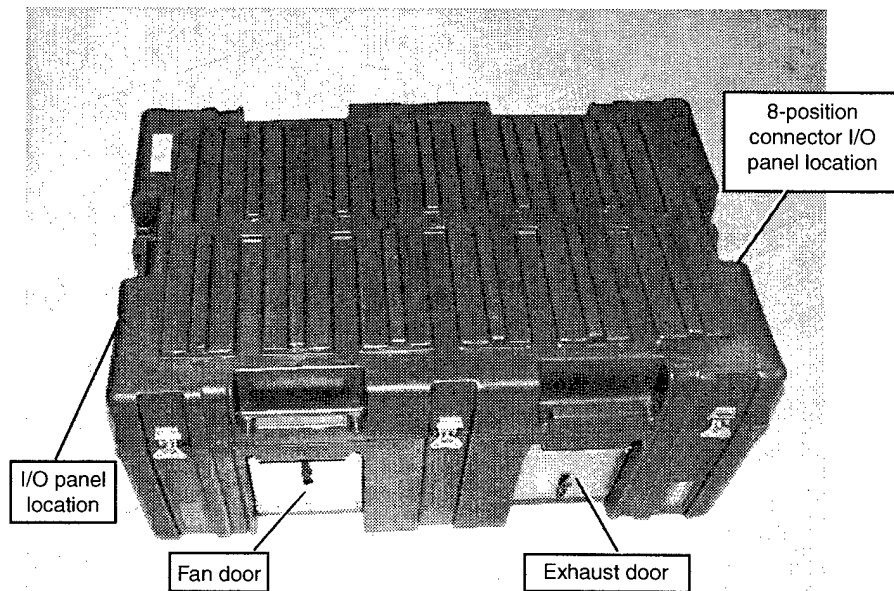

\*Mays, B., "Hardware overview for new acoustic sensor" (AMSRL-SE-SA internal memo), 2 February 1999.

Following conventional practice for particulate avoidance, we placed the fan just inside the filtered inlet port of the MCU so that the closed compartment is pressurized when the fan is on; thus air is drawn into the system only through the filtered inlet port and vented through the filtered exhaust port. As long as the inlet filter performs as designed, unanticipated gasket failures or other system compartment leaks cannot become inlet paths for unwanted particles as they would if the fan were placed in the exhaust port and used to evacuate the enclosure.

The fan door is hinged along its lower edge and the vent door along its upper edge. When unlatched for field operation of the MCU, the fan door flips down and remains open, while the vent door remains closed except when the climate control system turns the fan on; the door is then held partially open by the outgoing air until the fan is shut down (fig. 2).

### 2.1.3 MCU I/O Connector Panels

Known I/O requirements for the MCU at the outset included one group of eight identical 26-conductor cables to link to the eight ASCBs and a second miscellaneous group including dc input power, GPS antenna, and packet radio antenna. The eight 26-contact Mil-style bulkhead connectors for the ASCB cables fit into one of the container's end recesses, so the recess at the other end was left for the antenna and power connectors plus various items such as switches, pilot lights, and diagnostic/communication connectors not yet determined.

All I/O connectors and other devices needed to be well protected when the MCU was in its shipping configuration, and a recessed connector panel with a flange that seated on the recessed surface in the end of the container appeared to meet this need. A hinged door and latch would be

Figure 2. MCU with lid removed and I/O panel, fan, and exhaust doors in operational positions.

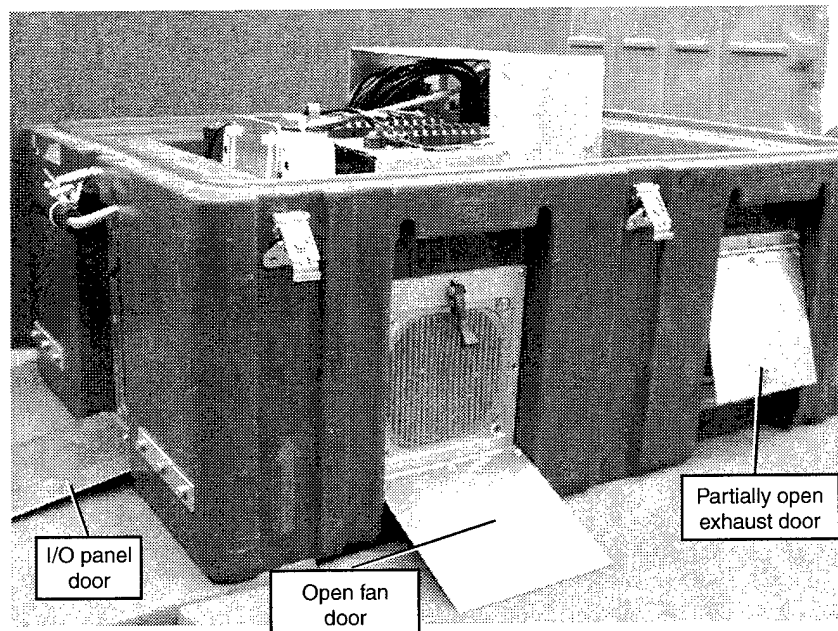

safely recessed during shipment, and the 2-in. foam lining inside the box was thick enough that the recessed connector panels would not encroach into the usable volume inside the container. We needed a simple rectangular box with a flange around the outside (like a typical stainless steel sink that drops into a countertop cutout). We searched standard cast aluminum BUD™ boxes and found a box that was readily adaptable for this application ( $7\frac{1}{2} \times 4\frac{3}{4} \times 1\frac{3}{4}$  in.). We fabricated aluminum flanges and attached them to the boxes using screws from the discarded lids. These assemblies formed the basic recessed connector panels for each end of the MCU. Then it was necessary only to add the appropriate device mounting-hole cutouts to the bottoms of the boxes. Figure 3 shows the I/O panel for the eight Mil-style bulkhead connectors.

## 2.2 Internal Components and Mounting Hardware

### 2.2.1 Floor Plate and Corner Mounting Brackets

A simple way to provide shock mounting for the MCU's internal components was to mount them to a flat plate that rested directly on the flat 2-in. foam lining on the base of the housing. (The next section provides additional details of this shock-mounting scheme.) We designed mounting brackets for the floor plate to be attached to the end walls of the housing near each of the four corners with through-bolts and outside stiffening plates (see fig. 3). Captive fasteners on the underside of these brackets allow the floor plate to be easily installed or removed. This drop-in, plate-mounted design provided two benefits essential to a program with a severely compressed schedule for brassboard to prototype to final design, fabrication, and assembly. First, it allowed a major portion of the

Figure 3. End view of MCU with lid removed.

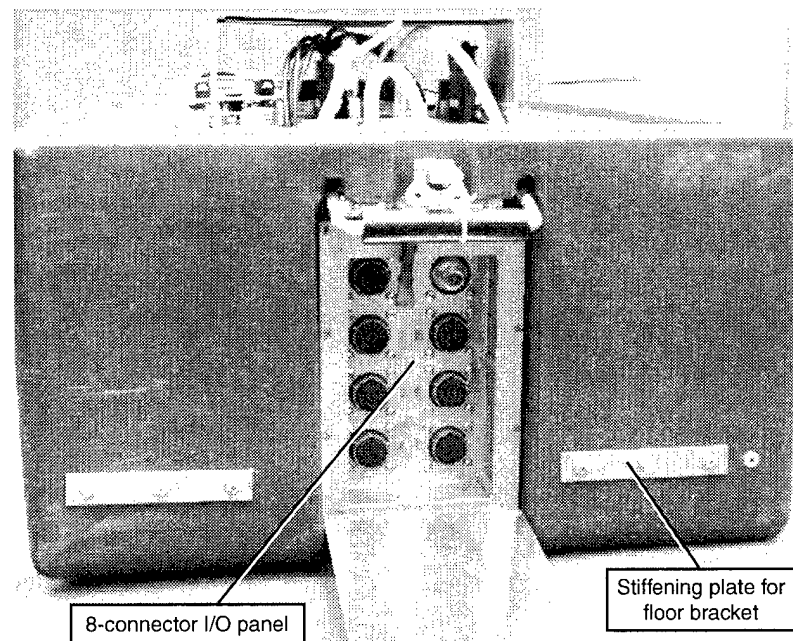

internal hardware fabrication to begin before the system configuration had been finalized: we were able to build mounting brackets for system components while we were optimizing component locations on the floor plate during brassboard and prototype testing; only the floor plate was delayed until component layout finalization. Second, it allowed internal components to be mounted and wired in an assembly-line fashion while the housings underwent modification and installation of ventilation and I/O hardware. Figure 4 shows the final layout of all MCU components as installed with all interconnection cables in place.

### 2.2.2 Compact PCI Chassis

In addition to an internal power supply, the compact PCI chassis houses computing, signal-processing, and some storage-media hardware for the MCU in a rigid 3U-high backplane-type VME (versa module Eurocard) card cage. As figure 5 shows, conventional mounting of the chassis would be in a horizontal configuration with backplane to the rear and the various plug-in components removable to the front. To save space and facilitate diskette removal, we decided it was best to mount the chassis vertically with its end panel flanges bolted flat to the MCU floor plate. The one drawback to this orientation was limited vertical clearance when all I/O cables were connected to the unit's front panel (now its top panel). When we selected the shipping cases, it was not apparent from the

Figure 4. Looking down into MCU with lid removed.

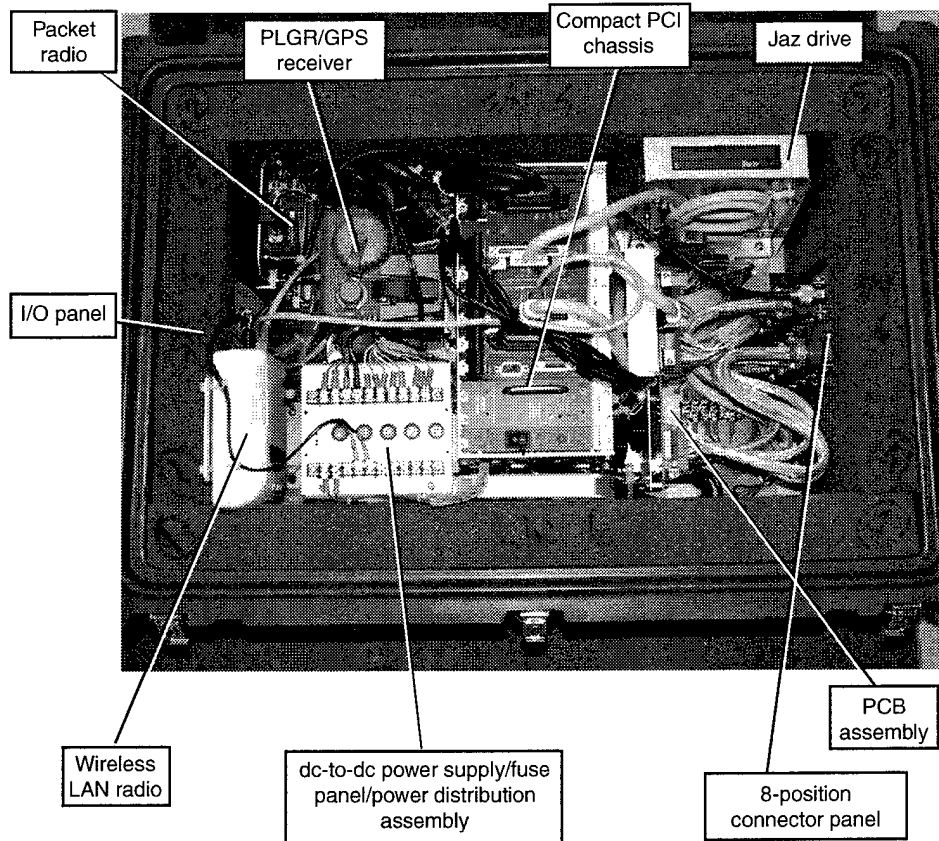

**Figure 5. Compact PCI chassis in conventional horizontal orientation.**

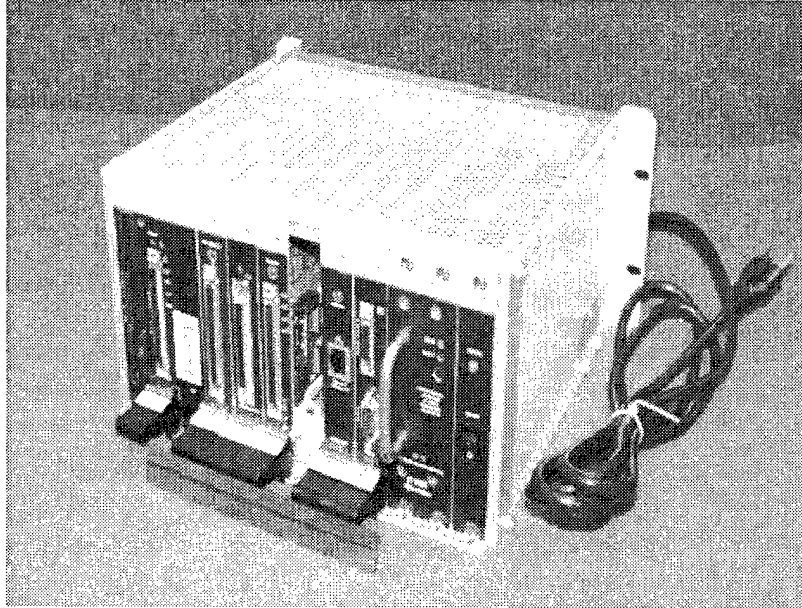

vendor's catalog that the inside case dimensions were for the bare-walled, unlined case. Thus the cases that were believed to have a comfortable margin of excess volume when ordered were in fact a little snug; after subtracting the 2-in. foam lining on all six interior walls, a box-shaped volume  $21.5 \times 13 \times 10.5$  in. remained for system hardware. Fortunately, vertical clearance for the PCI cables was the only real problem; all other system components were shorter and some margin in the case's length and width still remained. The additional cable clearance needed above the PCI chassis was about 2 in., and we made two modifications to gain this clearance.

The first modification was lowering the PCI chassis. As shown in figure 6, there is a little less than 1 in. of clearance beneath the PCI chassis when it is mounted vertically on the flanges of its end panels. Since the ac power cord was the only thing that extended into this space, we saw that the chassis could be lowered if the power cord were rerouted and the end panels shortened. Rather than cutting off the end panels and then having to fabricate and add mounting flanges, we determined that they could be detached and reattached 2 cm ( $\approx 0.8$  in.) higher up on the internal chassis corner rails. This was possible due to the VME-standard configuration of the chassis structural components—the end panels are made with a series of holes on 1-cm spacing, and all internal hardware matches this hole spacing. Thus when we moved the panels and shifted them upward by 2 cm, all of the mounting screws were merely moved down by 2 cm. The only panel modifications required for this shift were the addition of two screw holes in each panel (located 2 cm below the lowest existing holes) and the addition of two grommet holes in one panel—one for the rerouted ac power cord and the other for a dc power cable. The standard configuration of the compact PCI includes an ac-to-dc power converter/

Figure 6. Compact PCI chassis in alternate vertical orientation.

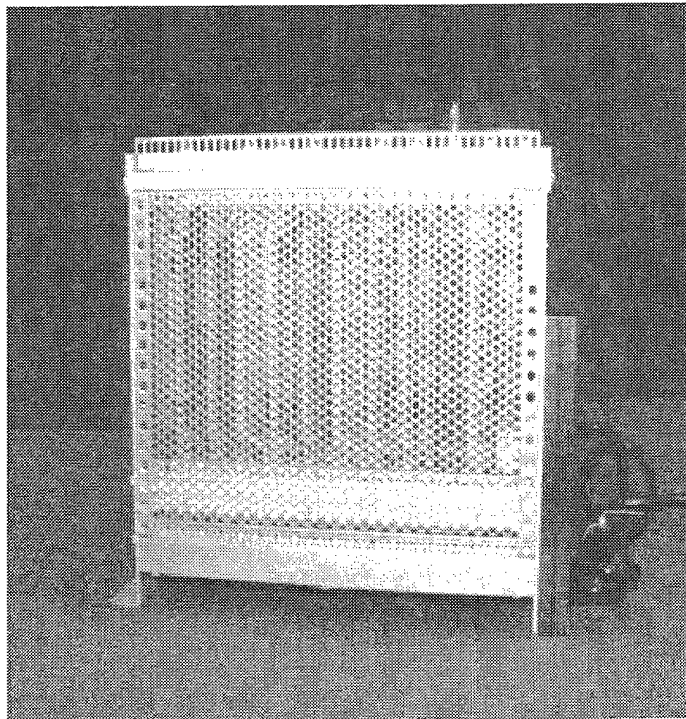

regulator with internal terminals for optional direct feed of dc power. Although the unit would operate via direct-feed dc in its fielded configuration in the MCU, we maintained the ac power option for operation and testing prior to final system assembly. Figure 7 shows the PCI chassis in its modified/lowered configuration.

We needed an additional 1¼-in. clearance, and the cable requiring this maximum clearance was also the least rugged of all those used. Thus it was critical to both provide the necessary clearance and prevent any intrusion into this clearance zone that might occur if the case lid flexed too far due to rough handling or some other unexpected abuse. Our electrical engineering staff provided a simple two-part design fix for this problem. A rectangular C-shaped brace was formed from sheet aluminum and bolted to the end panels of the PCI chassis to create a shield over the cables at the appropriate clearance height. This brace is shown in figures 2 and 3. The second part of the fix was to slice away a 1-in. layer of the case's foam lid liner so that when the lid is in place, there is a slight compression of the foam liner above the brace.

The above-described cable-clearance/protection fix also provided an essential element of the MCU system shock-mounting design. With the floor plate resting flat on the bottom layer of foam and tied to the four corner brackets, it was well supported in the downward direction but relatively unconstrained in the upward direction, due to the flexibility of the plate and corner brackets in this direction. With the rigid PCI chassis plus brace in the center of the floor plate, upward loading is transferred to the foam-lined case lid and the system is now cushioned and constrained

Figure 7. Compact PCI chassis after modification/lowering.

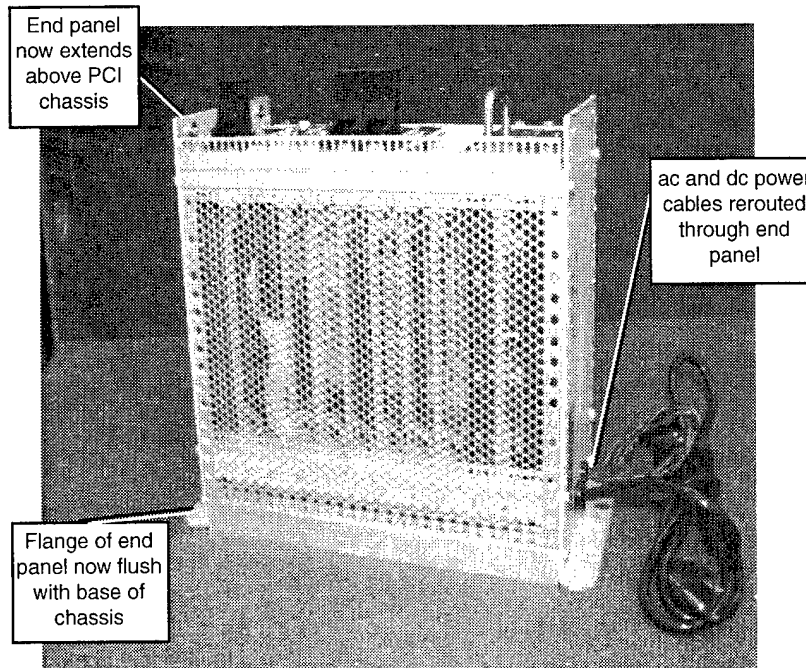

in both the up and down directions. Additional braces to provide this constraint were no longer necessary.

The foam lining on the side walls of the case plays no role in the MCU system shock-mounting design; all internal components are mounted with brackets bolted to the floor plate and no physical mechanism exists for horizontal load transfer to, or motion constraint by, this lining. Because the floor plate and corner brackets are relatively rigid in the horizontal direction, shock loads in this direction might be a problem for components rigidly mounted to the plate. Except for the PCI chassis, all internal component-mounting brackets are relatively flexible in the horizontal direction. With component centers of gravity well above the floor plate level, this flexibility reduces transmissibility of horizontal shock loading.

### 2.2.3 *Iomega Jaz Drive*

The Iomega Jaz drive is a removable-media SCSI device that we purchased in its internal configuration because of a slightly wider operational temperature range than specified for its stand-alone configuration. Mounting rails to fit standard desktop PC openings were included, and since space was available, we used the rails to mount the device to its floor-attachment bracket. If future system changes require tighter spacing, the rails could be eliminated but the bracket would be a little more difficult to fabricate. Figure 8 shows the mounting bracket as installed on the floor plate (see also fig. 4 and 9).

Figure 8. MCU system components and empty mounting brackets installed on floor plate.

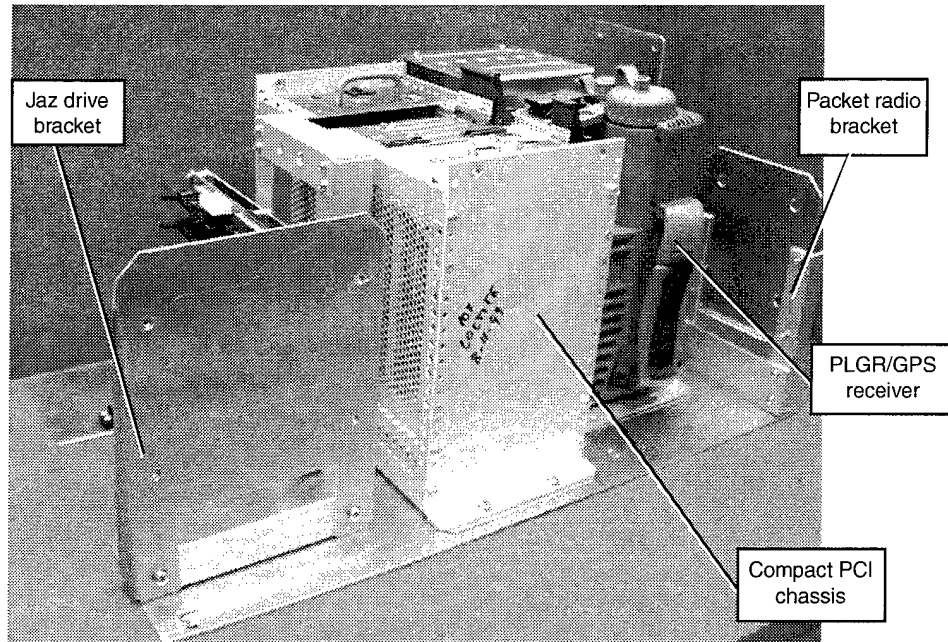
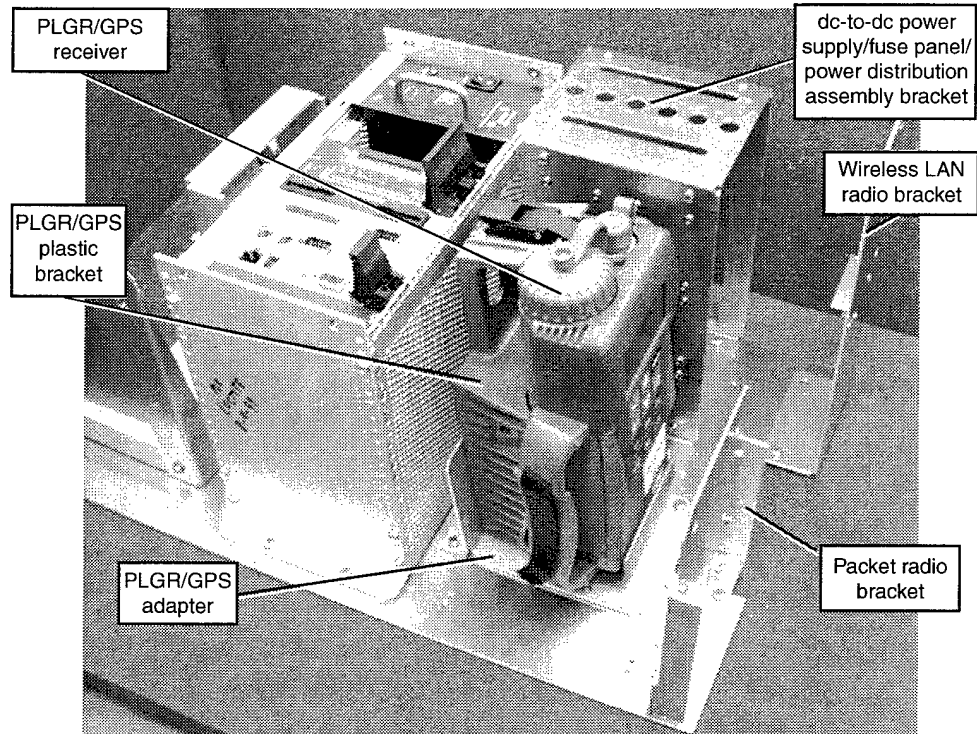

Figure 9. MCU system components and empty mounting brackets installed on floor plate.



### **2.2.4 *Precision Lightweight Global Positioning Satellite Receiver***

The PLGR is delivered in its military configuration with a rigid thermoplastic mounting bracket that closely conforms to the irregular exterior of the receiver—a quick-release latch allows easy removal or installation of the receiver. Since the bracket was configured to be bolted to a vertical surface, we fabricated a simple adapter to match the bolt pattern of the bracket and then bolted the entire assembly to the MCU floor plate (see fig. 8 and 9).

### **2.2.5 *Packet Radio***

The packet radio is a rectangular, box-shaped device approximately  $1 \times 3 \times 6$  in. with connectors at each of the  $1 \times 3$ -in. ends—a dc power connector and a DE-9 interface connector at one end, as well as a BNC jack for the antenna cable at the other end. We mounted the radio vertically about 2 in. above the floor plate with the antenna connector facing downward. The radio was attached with nylon cable ties to a flat plate with a formed lip at its lower edge to prevent vertical slippage. We attached this plate to an aluminum-angle frame, which was bolted to the MCU floor plate (see fig. 4, 8, and 9).

### **2.2.6 *Aironet Series 4500 Wireless LAN Radio***

The Aironet wireless LAN radio is a rectangular, box-shaped device approximately  $1\frac{1}{2} \times 4 \times 5$  in. with all connectors at one of the  $1\frac{1}{2} \times 4$ -in. ends—a dc power connector, a reverse-SMA jack antenna connector, an eight-position modular receptacle, and a DE-9 RS-232 connector. We mounted the radio with cable ties to a formed vertical plate—it was flipped so that its  $4 \times 5$ -in. base was against the vertical plate and one of its  $1\frac{1}{2} \times 5$ -in. sides rested on a support lip that was  $5\frac{1}{2}$  in. above the MCU floor plate (see fig. 4, 8, and 9).

### **2.2.7 *Dc-to-dc Power Supply/Fuse Panel/Power Distribution Assembly***

This assembly consists of (1) six  $2\frac{3}{8} \times 2\frac{3}{8} \times \frac{3}{8}$ -in. high dc-to-dc power supplies mounted in three rows of two each on a  $5 \times 9$ -in. flat plate, (2) a  $5 \times 4\frac{1}{2}$ -in. plate (attached horizontally to the top edge of the first plate) with six fuse holders and two 10-position terminal strips, and (3) a vertical support bracket from the free edge of the second plate to the MCU floor plate (see fig. 4, 9, and 10). The vertical support bracket is directly in front of the fan, so we provided a cutout to allow airflow directly onto the power supplies.

Figure 10. Dc-to-dc power supply/fuse panel/power distribution assembly mounting hardware.

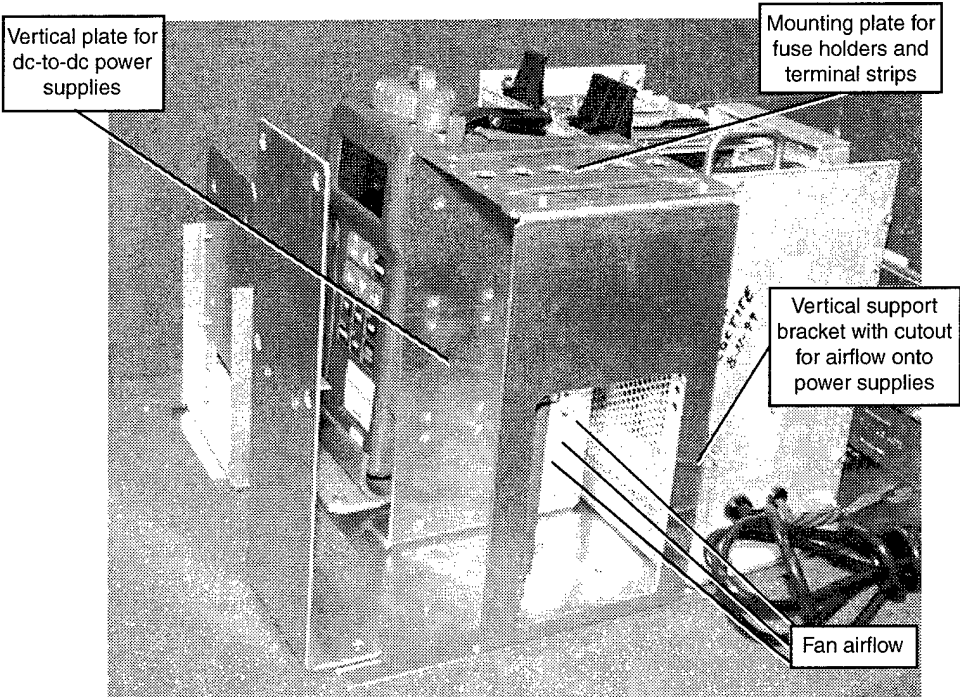

## **Appendix A.—MCU Housing Modification and Assembly Notes**

## Symbols and Acronyms

Ø	diameter
PHCS	pan-head cap screw
SS	stainless steel
FH	flat-head
s/n	serial number
a/r	as required

## Fabrication and Assembly

1. Mark s/n on lid and main box.
2. Mark corner numbers on long foam sections (fig. A-1).
3. Remove two end foam pieces; cut off portion (a/r) of the four remaining approximately 1- × 1- × 4-in. foam spacers (one per corner) to about 1 in. above “floor” level to give room for Floor Mounting Brackets (SK MRP074).
4. Use permanent Sharpie pen and mark box s/n and corner numbers as follows on four Floor Mounting Brackets (SK MRP074):
  - 2 ea SK MRP074-1: corners 1 and 3
  - 2 ea SK MRP074-2: corners 2 and 4
5. Drill box for each bracket as follows:
 

Required:

  - 4 ea Backup Plates, SK MRP074-3
  - 12 ea #10-32 × ¾-in. PHCS plus lockwashers
  - Ø5/32-in. drill
  - Ø0.203-in. drill

**Figure A-1. Corner numbering of MCU housing.**

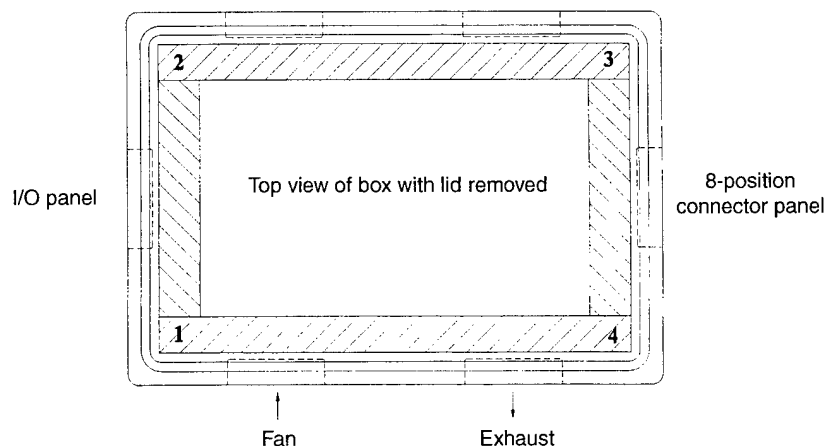

Brackets for corners 1, 2, and 4 should be located flush against both inside walls of their respective corners.

*Bracket for corner 3 should be located flush against the inside end of the box and the side wall of the recess for the 8-position connector panel.*

Procedure: Position box on end on work surface with adequate overhang for through-drilling (may clamp to table with large Knu-Vise or C-clamp):

- Hold bracket flush against foam floor and walls of box and use innermost Pem™ nut as drill guide to drill  $\frac{5}{32}$ -in. hole through box end wall. Repeat for remaining brackets—*be sure to locate bracket for corner 3 correctly per above note.*
  - Remove brackets, place box on end on floor, and using a #10-32 screw in self-tapping mode, attach a Backup Plate (SK MRP074-3) to each of the two  $\frac{5}{32}$ -in. holes. Use a machinist's square to align plates parallel with box bottom and use the plates as drill guides to drill two  $\text{Ø}0.203$ -in. holes through box at each plate location. Remove plates and drill out the remaining two  $\text{Ø}\frac{5}{32}$ -in. holes to  $\text{Ø}0.203$  in.
  - Flip box over onto opposite end and repeat the above for remaining two bracket locations.
  - Place box on horizontal work surface and install brackets and Backup Plates using three screws at each location.
6. Location/drilling of Floor Plate (SK MRP070):

Required:

- 2 ea small C-clamps
- $\frac{1}{8}$ - and  $\frac{1}{4}$ -in. drills
- piece of angle bracket or other material to align one end of plate
- number punches

With four Floor Mounting Brackets (SK MRP074) tightly in place and end foam pieces reinstalled:

- Place the Floor Plate (SK MRP070) on a horizontal surface with the Pem nuts face down. The Floor Plate has a  $\frac{1}{16}$ -in. pilot hole at each corner-mounting point—three are located 1 in. from the long edge and 0.65 in. from the short edge, and the fourth is 2.1 in. from the long edge and 0.40 in. from the short edge. This odd one corresponds to corner #3 and is adjacent to the cutout in the plate for the 8-position connector panel.
- Stamp s/n of box on top surface of plate next to the cutout at the 8-position connector panel end.

- Place the Floor Plate (SK MRP070) in the box with the #3 corner over the #3 Floor Mounting Bracket, and center the plate while aligning it parallel to one end with appropriate material (piece of aluminum angle, etc.). C-clamp the Floor Plate to two of the brackets.
- Floor Plate has  $\frac{1}{16}$ -in. pilot hole at each corner-mounting point—drill  $\frac{1}{8}$ -in. hole at these locations through plate and bracket. (It may help to insert #6 screw or appropriate transfer punch after each hole is drilled to minimize motion.)
- Remove plate and redrill corner holes to 0.250 in. and deburr. **Plate is now ready for system hardware installation.**
- Remove end foam pieces (save) and four Floor Mounting Brackets with Backup Plates; redrill the plate-mounting holes to 0.250 in. (do not deburr bottom side) and install #10-32 Pem nut on bottom side. Set aside for final box assembly.

7. Box end modifications and handle removal:

Required:

- Sharp knife/exacto tool, sharp shears (Craftsman)
- Vise-grip™ sheet metal pliers (wide, “duckbill” style)
- $\text{Ø}\frac{3}{16}$ -in. drill
- Handle Backup Plate (SK MRP089)
- Procedure (repeat at each end):
  - Use  $\text{Ø}\frac{3}{16}$ -in. drill to drill out three rivets. Remove handle and inside backer plate; discard plate and set aside handle for final assembly.
  - Install Handle Backup Plate with two #10-32 screws (narrow offset edge of plate downward) and use lower edge as guide to lightly scribe a line on the inside (double) wall of box. Extend scribed line equally to either side to accommodate connector panel back frame ( $\approx 5.6$  in. wide). Remove plate and set aside for final assembly.
  - Separate double-walled section at inside over handle location and scrape out adhesive as required for next step.
  - Use rigid straight edge as guide about  $\frac{1}{16}$  in. *above* scribed line and make several passes with sharp knife for entire 5.6-in. width. Using shears, make vertical cuts from lower edge of inside wall to each end of 5.6-in. cut.
  - Grasp the rectangular piece of the inside wall with the Vise-grip pliers and flex back and forth until it breaks free—it may be necessary to make more cuts with sharp knife.

8. Mark panel locations as follows prior to next steps. Dimensions are from bottom surface of box (which is about  $\frac{1}{2}$  in. above patterned seating surface) to lower edge of panels:
  - end connector panels =  $\frac{5}{16}$  in.
  - fan and exhaust panels =  $1\frac{3}{8}$  in.
9. Box end connector and I/O panel modifications:

Required:

- Sharp knife, three-sided scraper, deburring tool, reciprocating saw, and file
- $\frac{5}{16}$ - and  $\frac{1}{2}$ -in. sheet metal drills
- #4 sheet metal screws
- $\frac{1}{16}$ ,  $\frac{3}{32}$ , and  $\frac{5}{32}$ -in. drills
- Connector Panel Back Frame (SK MRP060)—use as drill guide and template for cutout

Procedure:

- Position Connector Panel Back Frame in recess of box end with #4-40 hole at top center; check/adjust position using handle removed in step 7—top of frame right against handle plate.
- Using  $\frac{3}{32}$ -in. drill, drill through the four corner screw holes (#6-32) and then fasten the frame in place with 4 ea #4 sheet metal screws.
- Drill through the five remaining #6-32 holes with same drill and then through the #4-40 hole with the  $\frac{1}{16}$ -in. drill.
- Using the inside perimeter of frame as a template, scribe/score several times around as deeply as possible into the plastic.
- Drill at each corner with  $\frac{5}{16}$ -in. sheet metal drill and then remove the frame and set aside for final installation.
- Drill several overlapping holes in the center of the cutout with the  $\frac{1}{2}$ -in. sheet metal drill to allow entry of the reciprocating saw blade. Cut "X" pattern from center to each corner and then grasp and flex the four triangular pieces until they break away (may have to make additional cuts with sharp knife).
- Clean up rough edges with deburring tool or file. Check cutout size for easy clearance with BUD™ box/connector panel and adjust as required.
- Redrill all holes with  $\frac{5}{32}$ -in. drill.
- Repeat at other end of box.

## 10. Box end 8-position connector and I/O panel installation:

## Required:

- 2 ea Connector Panel Back Frame (SK MRP060)
- 2 ea Connector Panel Frame (SK MRP059)
- 2 ea rubber tab-handle/bracket portion of Southco™ Flexible Draw Latch (p/n 37-10-051-20)
- 2 ea Pop™ rivet— $\frac{1}{8}$ -in. sealed dome head
- 2 ea #4-40  $\times \frac{7}{8}$  or 1-in. SS PHCS with lockwasher
- 12 ea #6-32  $\times \frac{1}{2}$ -in. SS FH screws
- 8 ea #6-32  $\times \frac{3}{4}$ -in. SS FH screw
- 12 ea #6-32  $\times \frac{3}{4}$ -in. SS PHCS with lockwasher
- 1 ea modified BUD box for 8-position connectors (SK MRP061)
- 2 ea End Panel Hinged Door Assembly (no drawing—see SK MRP076)
- 2 ea Hinge Spacer (SK MRP076-2)
- Loctite™ #242

## Procedure: 8-position connector panel end of box:

- Position the rubber tab-handle/bracket over the two holes at the top center of the frame and attach it to frame using a Pop rivet from the back side of the frame through the lower (counterbored) hole in the frame.
- Attach modified BUD box to Connector Panel Frame with 6 ea #6-32  $\times \frac{1}{2}$ -in. SS FH screws and Loctite.
- Place back frame inside box opening and attach frame/box subassembly with 4 ea #6-32  $\times \frac{3}{4}$ -in. SS FH screws and Loctite.
- Install 2 ea #6-32  $\times \frac{3}{4}$ -in. PHCS with lockwasher in the upper corners of the frame.
- Install a #4-40  $\times \frac{7}{8}$  or 1-in. SS PHCS with lockwasher into the upper hole of the rubber tab-handle/bracket.
- Place a Hinge Spacer over the bottom three frame holes and install an End Panel Hinged Door Assembly over it using 3 ea #6-32  $\times \frac{3}{4}$ -in. PHCS with lockwasher.

## Procedure: I/O panel end of box:

- Same as above except skip second step—modified BUD box installed later.

11. Box fan and exhaust modifications:

Required:

- Template and sharp serrated knife to cut foam
- Sharp knife, three-sided scraper, deburring tool, reciprocating saw, and file
- $\frac{5}{16}$ - and  $\frac{1}{2}$ -in. sheet metal drills
- #4 sheet metal screws
- $\frac{3}{32}$ - and  $\frac{1}{8}$ -in. drills
- Filter Cover Panel (SK MRP066)—use as drill guide and template for cutout

Procedure:

- Position template against long section of foam at front of box and mark openings for fan and exhaust; cut and remove foam.
- Position Filter Cover Panel in left recess of box front; using  $\frac{3}{32}$ -in. drill, drill through the four corner screw holes ( $\text{Ø}0.125$  in.) and then fasten the frame in place with 4 ea #4 sheet metal screws.
- Drill through the five remaining frame holes with  $\frac{1}{8}$ -in. drill.
- Using the inside perimeter of frame as a template, scribe/score several times around as deeply as possible into the plastic.
- Drill at each corner with  $\frac{5}{16}$ -in. sheet metal drill and then remove the frame and set aside for final installation.
- Drill several overlapping holes in the center of the cutout with the  $\frac{1}{2}$ -in. sheet metal drill to allow entry of the reciprocating saw blade. Cut "X" pattern from center to each corner and then grasp and flex the four triangular pieces until they break away (may have to make additional cuts with sharp knife).
- Clean up rough edges with deburring tool or file. Check cutout size for easy clearance with fan and adjust as required.
- Redrill four corner holes with  $\frac{1}{8}$ -in. drill.
- Repeat at right recess of box front for exhaust opening, again using Filter Cover Panel as template for cutout and mounting holes.

12. Fan and exhaust installation:

Required:

- 1 ea Fan Frame Mount (SK MRP063)

- 1 ea Fan Back Panel (SK MRP064)
- 1 ea Filter Mount Assembly (SK MRP065)
- 1 ea Filter Cover Panel (SK MRP066)
- 1 ea Fan, Interfan (p/n PM082-24D-4B)
- Ø0.196-in. drill
- 4 ea Rivnut™ (p/n S6B321), #6-32 × 100° FH × 0.281–0.321 grip
- 2 ea rubber tab-handle/bracket portion of Southco Flexible Draw Latch (p/n 37-10-051-20)
- 2 ea Pop rivet— $\frac{1}{8}$ -in. sealed dome head
- 12 ea #4-40 ×  $\frac{7}{8}$  or 1-in. SS PHCS w/lockwasher
- 4 ea #4-40 ×  $\frac{3}{4}$ -in. FH screw
- 2 ea Fan/Exhaust Hinged Door Assembly (no drawing—see SK MRP075)
- 2 ea Hinge Spacer (SK MRP075-2)
- Loctite #242

Procedure—Fan:

- Position the rubber tab-handle/bracket over the two holes at the top center of the Fan Frame Mount and attach it to frame using a Pop rivet from the back side of the frame through the lower (counterbored) hole.
- Check rotation/flow direction arrows on fan. Flow must be into the box; therefore, the fan flange that the flow arrow points away from must be attached to the inside surface of the Fan Frame Mount. Identify this fan flange and redrill the four corner-mounting holes with the 0.196-in. drill.
- Place the fan on horizontal surface with the redrilled flange up and position the frame over it so that the four countersunk holes around the circular opening are aligned with the fan-mounting flange holes and the red and black fan power leads are toward the top of the frame.
- Place the four Rivnuts into the holes to maintain position and then set the Rivnuts one at a time.
- Place Fan Back Panel inside box opening, position frame/fan subassembly with latch toward top of box, and attach frame/fan subassembly with 2 ea #4-40 ×  $\frac{3}{4}$ -in. SS FH screws and Loctite.
- Install 2 ea #4-40 ×  $\frac{7}{8}$  or 1-in. SS PHCS with lockwasher in the upper corners of the frame.

- Install a #4-40  $\times$   $\frac{7}{8}$  or 1-in. SS PHCS with lockwasher into the upper hole of the rubber tab-handle/bracket.
- Place a Hinge Spacer over the bottom three frame holes and install an End Panel Hinged Door Assembly over it using 3 ea #4-40  $\times$   $\frac{7}{8}$  or 1-in. SS PHCS with lockwasher.

Procedure—Exhaust:

- Position the rubber tab-handle/bracket over the two holes at the top center of the Filter Cover Panel and attach it to the panel using a Pop rivet from the back side of the panel through the lower (counterbored) hole.
- Place Filter Mount Assembly inside box opening, position Filter Cover Panel with latch now toward bottom of box, and attach it to Filter Mount Assembly with 2 ea #4-40  $\times$   $\frac{3}{4}$ -in. SS FH screws and Loctite.
- Install 2 ea #4-40  $\times$   $\frac{7}{8}$  or 1-in. SS PHCS with lockwasher in the lower corners of the panel.
- Install a #4-40  $\times$   $\frac{7}{8}$  or 1-in. SS PHCS with lockwasher into the remaining hole of the rubber tab-handle/bracket.
- Place a Hinge Spacer over the top three panel holes and install a Hinged Door Assembly over it using 3 ea #4-40  $\times$   $\frac{7}{8}$  or 1-in. SS PHCS with lockwasher.

## Appendix B.—MCU Parts Fabrication Drawings

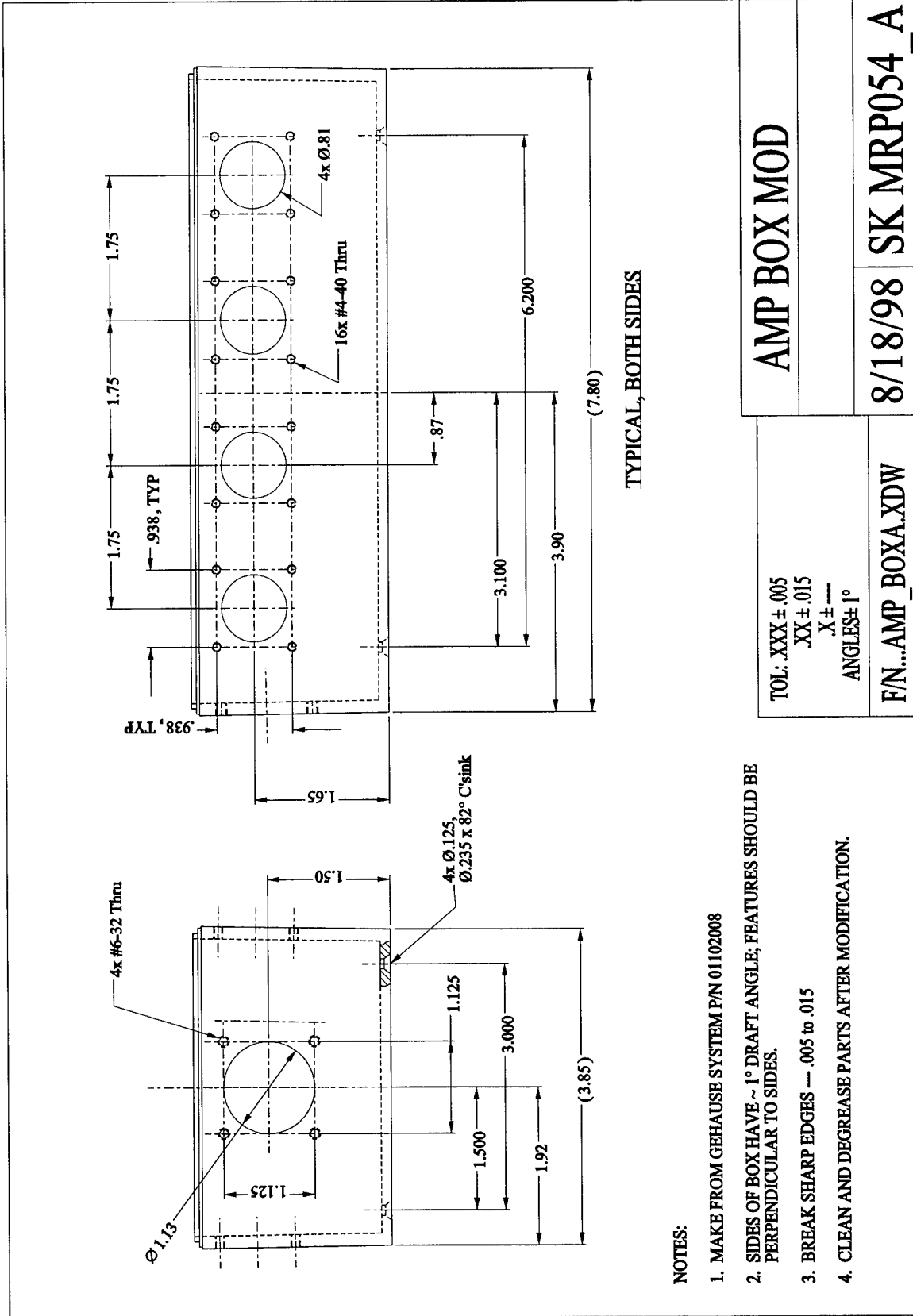

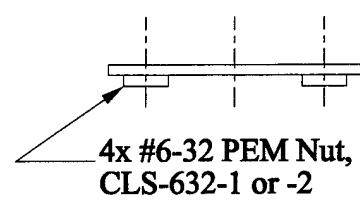
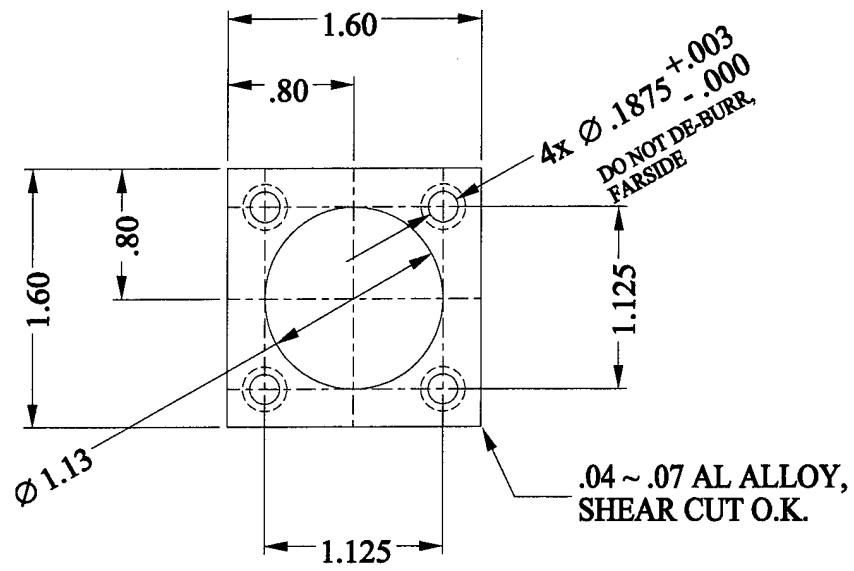

P/N	DESCRIPTION
--1	AS DRAWN
--2	WITHOUT Ø1.13 HOLE
<b>RECEPTACLE NUTPLATE MS3472-W16-26P or -S</b>	
9/29/98	SK MRP055_A

TOL: .XXX ± .005 .XX ± .015 .X ± — ANGLES ± —
NUTPLT_A.XDW

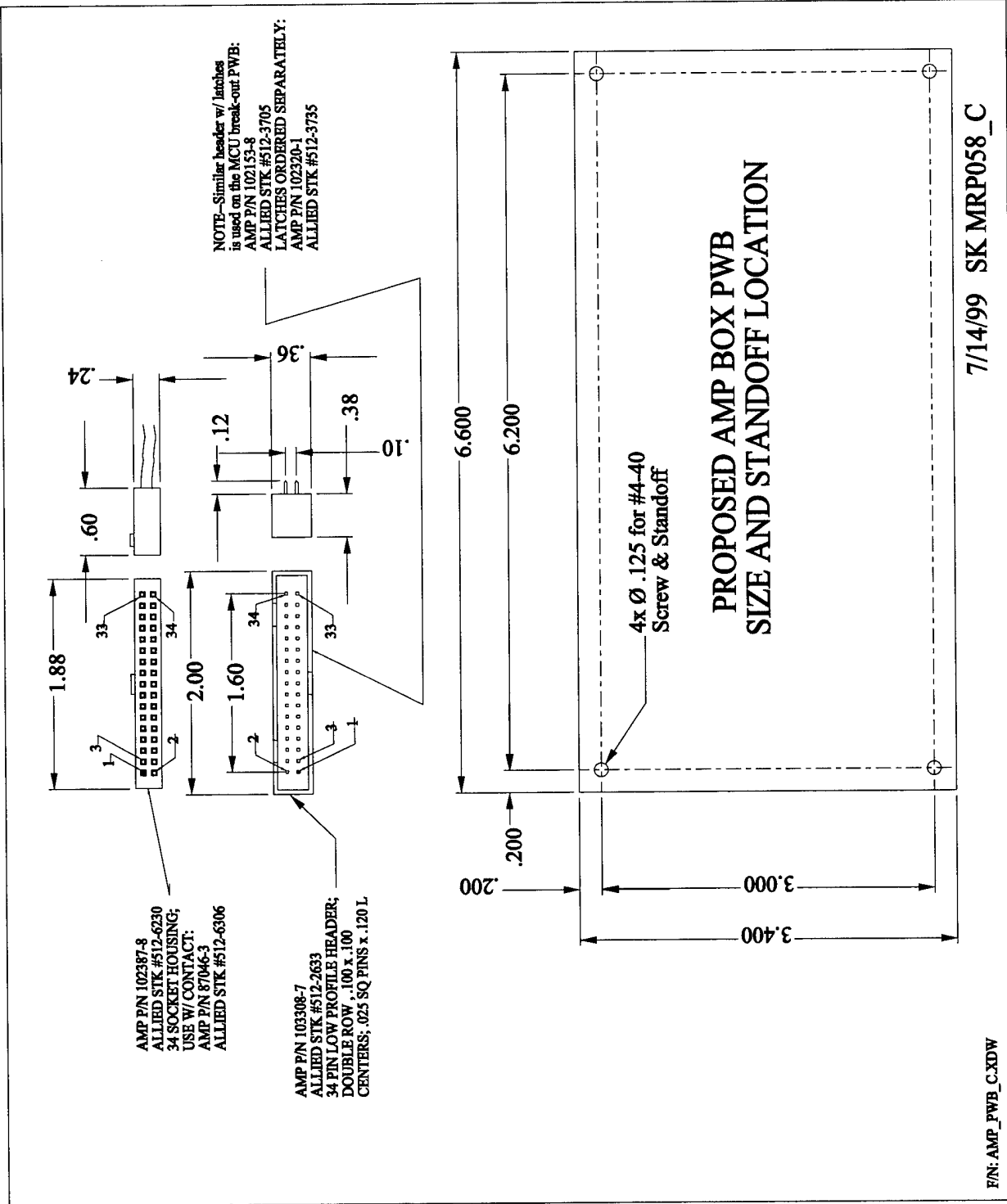

7/14/99 SK MRP058\_C

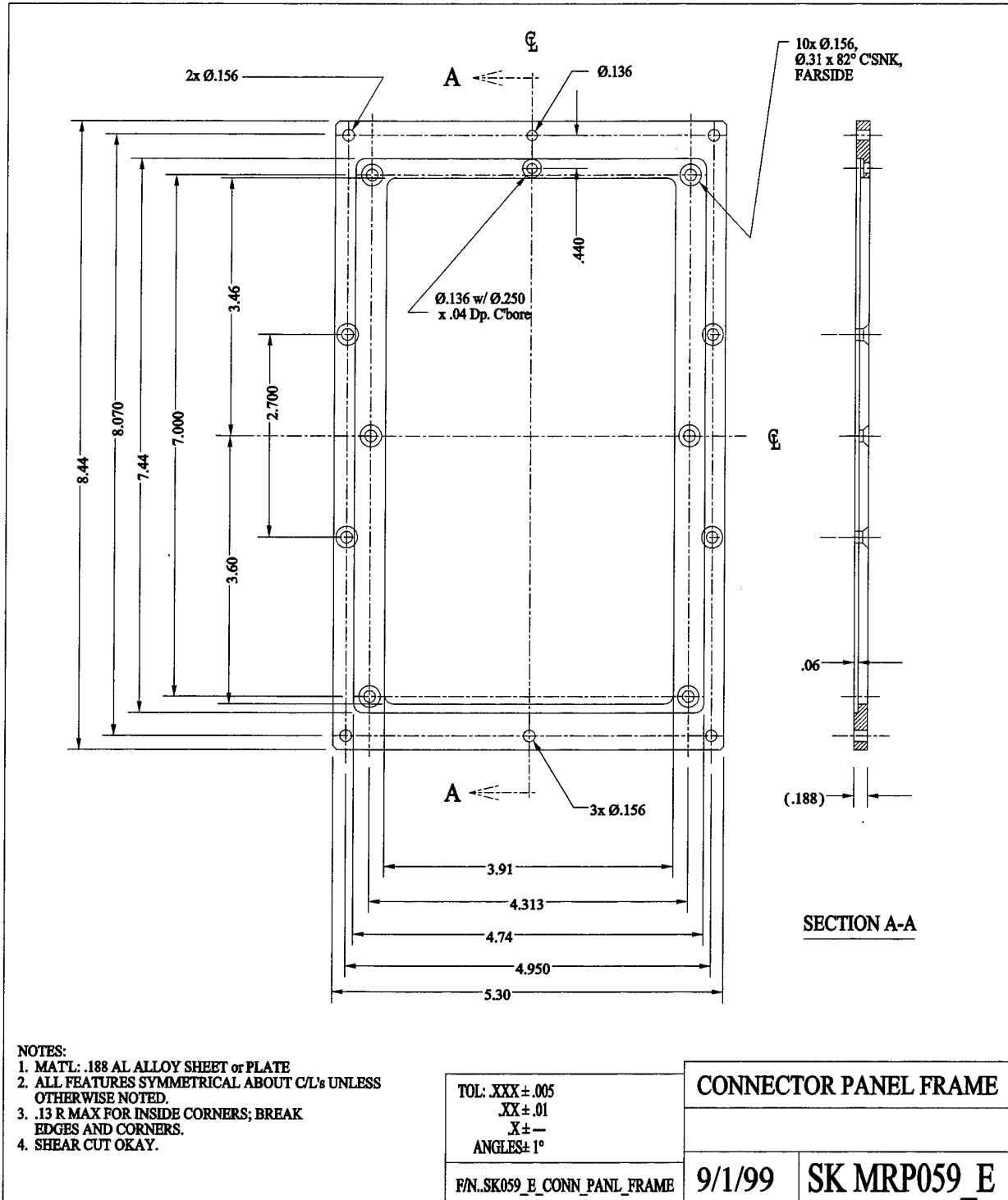

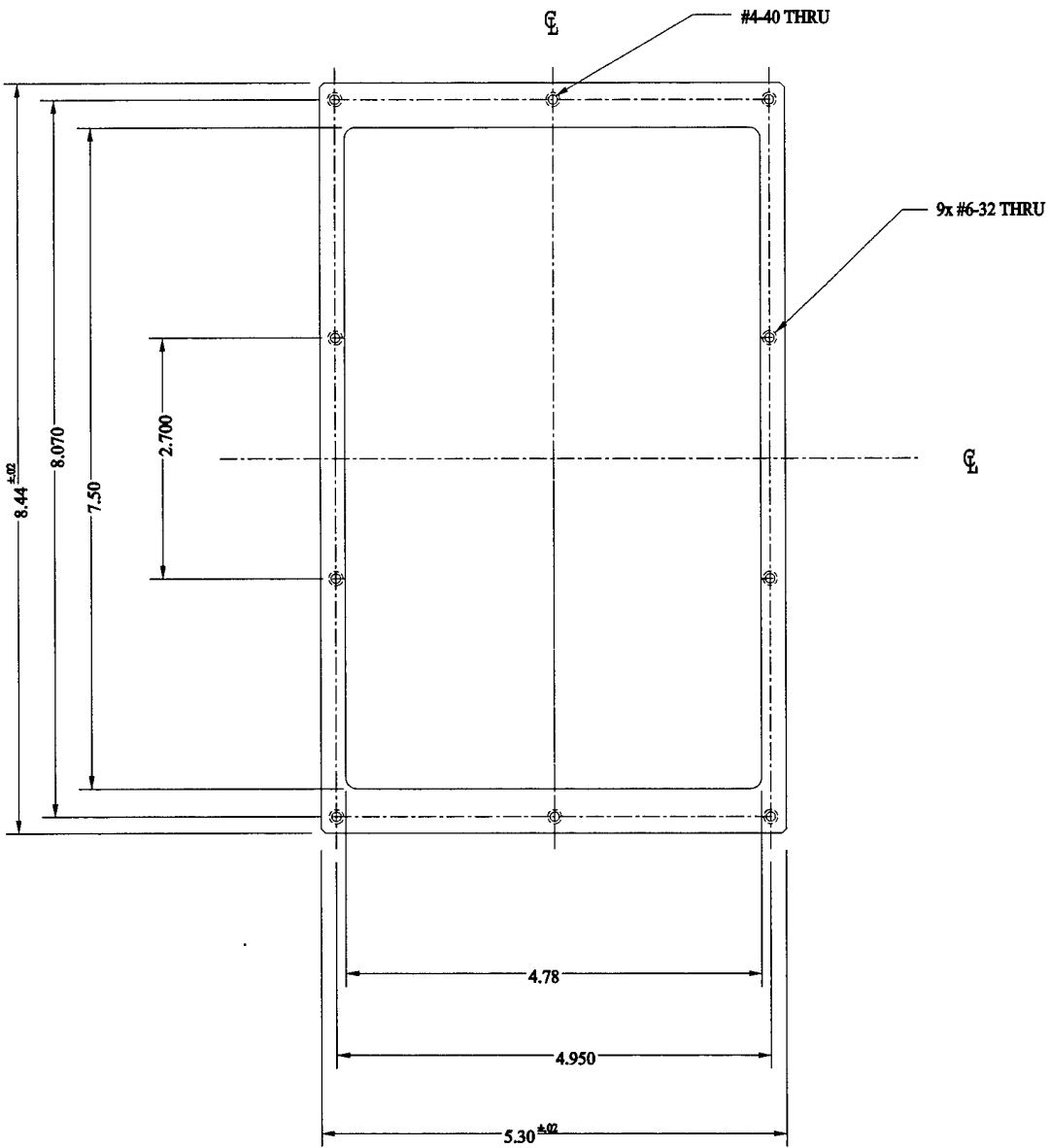

NOTES:

1. MATL: .188 AL ALLOY SHEET or PLATE
2. ALL FEATURES SYMMETRICAL ABOUT C/L's UNLESS OTHERWISE NOTED.
3. .13 R MAX FOR INSIDE CORNERS; BREAK EDGES AND CORNERS.
4. SHEAR CUT OKAY.

TOL: .XXX ± .005  
 .XX ± .01  
 X ± —  
 ANGLES ± 1°

**CONNECTOR PANEL  
 BACK FRAME**

F/N.SK060\_B\_BACK\_FRAME

6/15/99 SK MRP060\_B

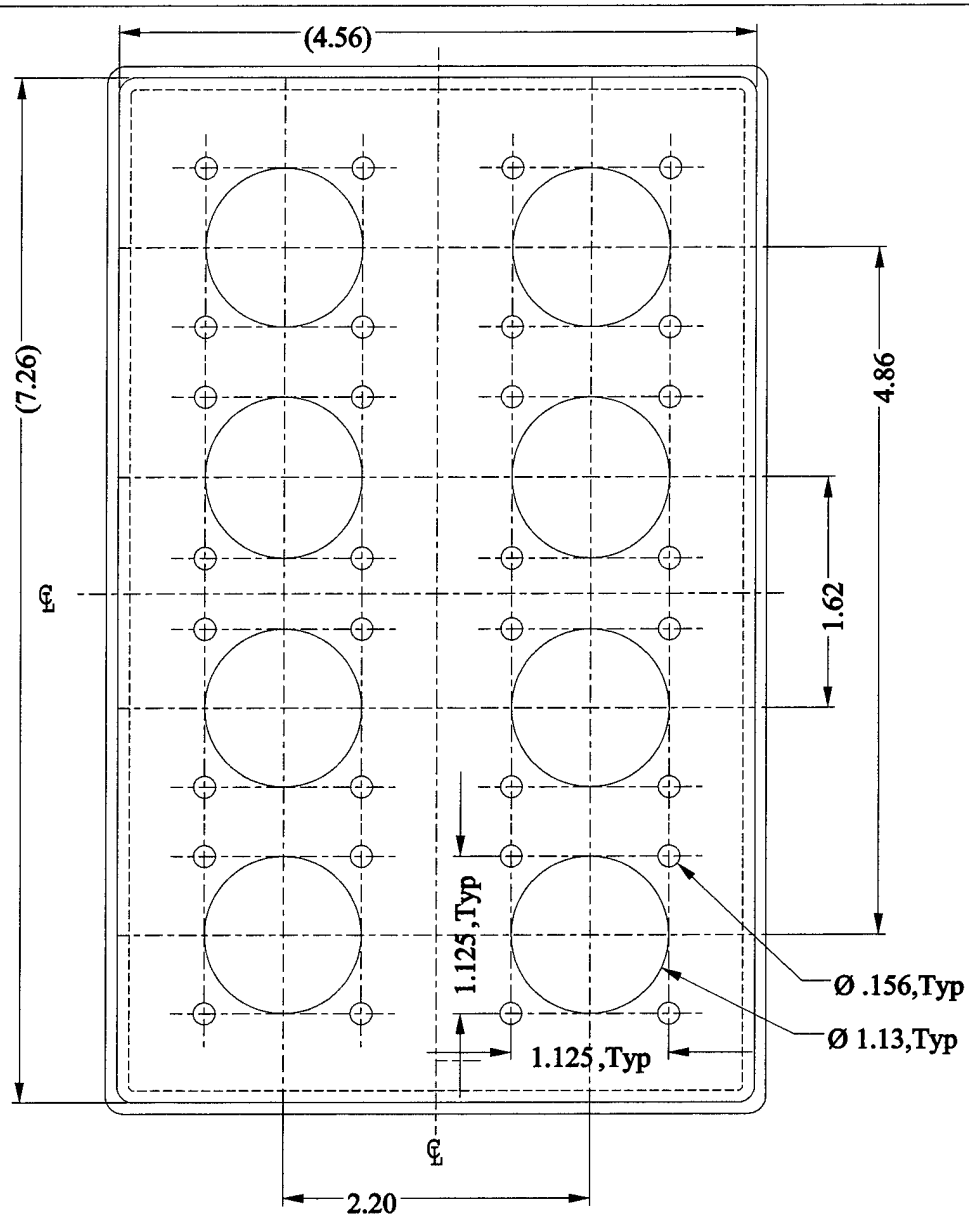

- NOTES:  
 1. VIEW SHOWN IS OUTSIDE BOTTOM OF BOX – BUD# CU-247.  
 2. UNLESS OTHERWISE NOTED, FEATURES ARE SYMMETRICAL ABOUT C/L's OF BOX BOTTOM.

TOL: .XXX±.005 .XX±.015 .X±— ANGLES±—	BUD: CU-247 MOD for 8 MS3472-W16-26P or -S	
	BUD8CON_A.XDW	5/24/99

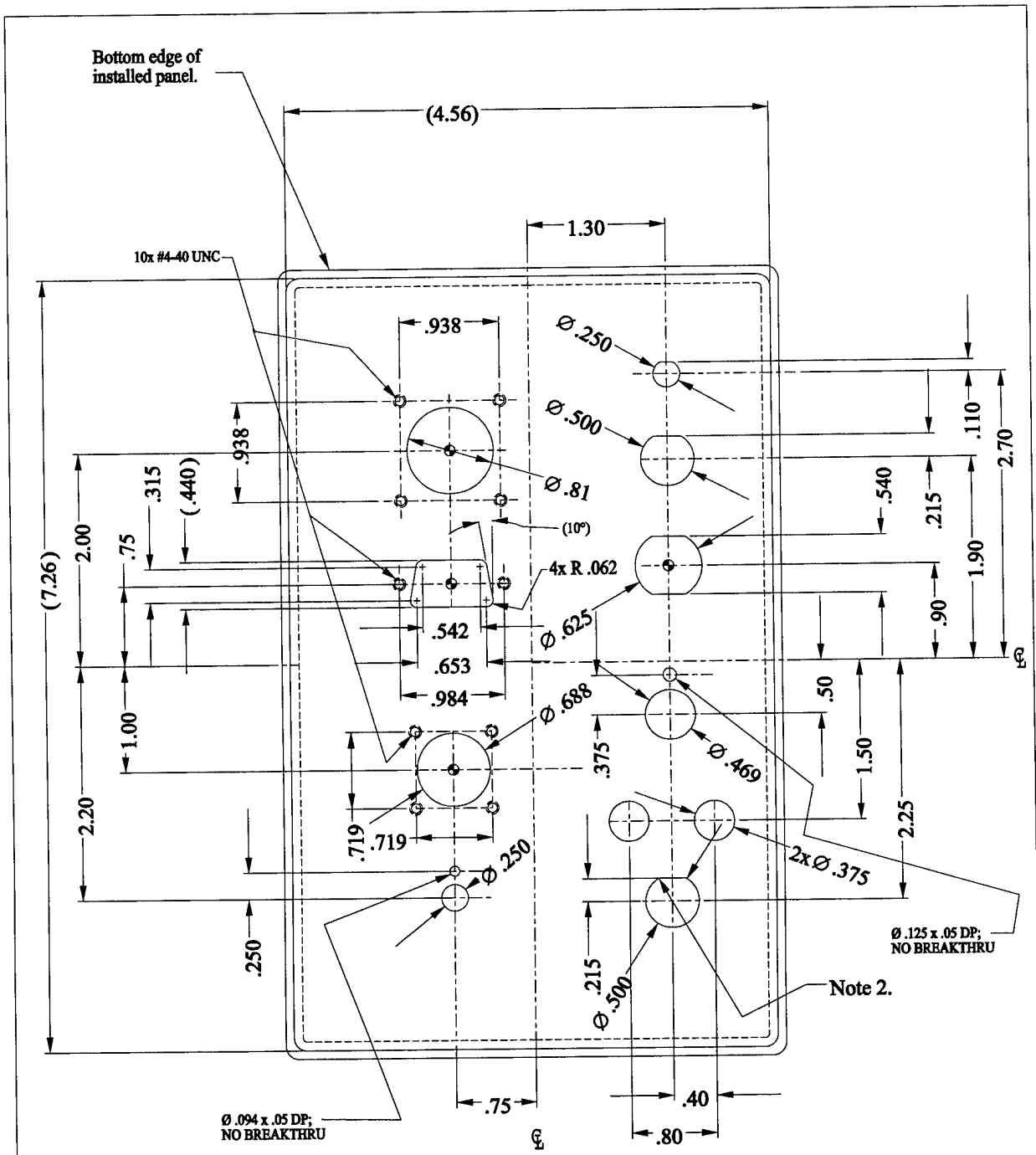

NOTES:

1. VIEW SHOWN IS OUTSIDE BOTTOM OF BOX - BUD# CU-247.
2. MAX .032 R FOR INSIDE 'CORNERS' OF ALL 'D' AND 'DOUBLE-D' FEATURES.
3. CUTOUTS, PATTERNS, ETC. SHOULD BE ASSUMED TO BE SYMMETRICAL ABOUT THEIR CENTERLINES FOR CASES WHERE 1/4-OFFSET DIMENSIONS ARE OMITTED.

TOL: .XXX ± .005
.XX ± .015
X ± —
ANGLES ± —

BUD: CU-247 MOD for  
ANTENNAS AND PWR

BUD\_PWR\_D.XDW

6/15/99 SK MRP062\_D

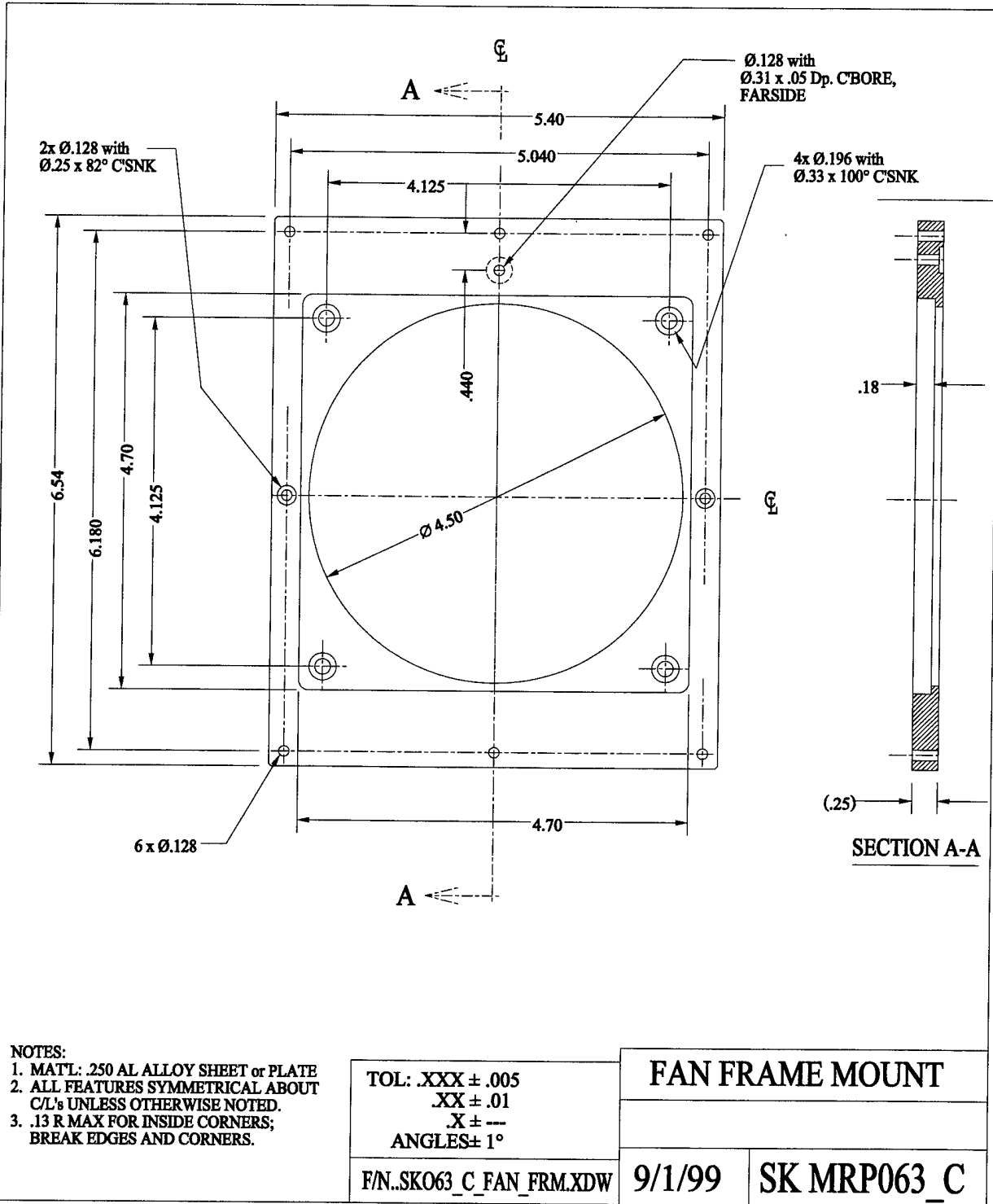

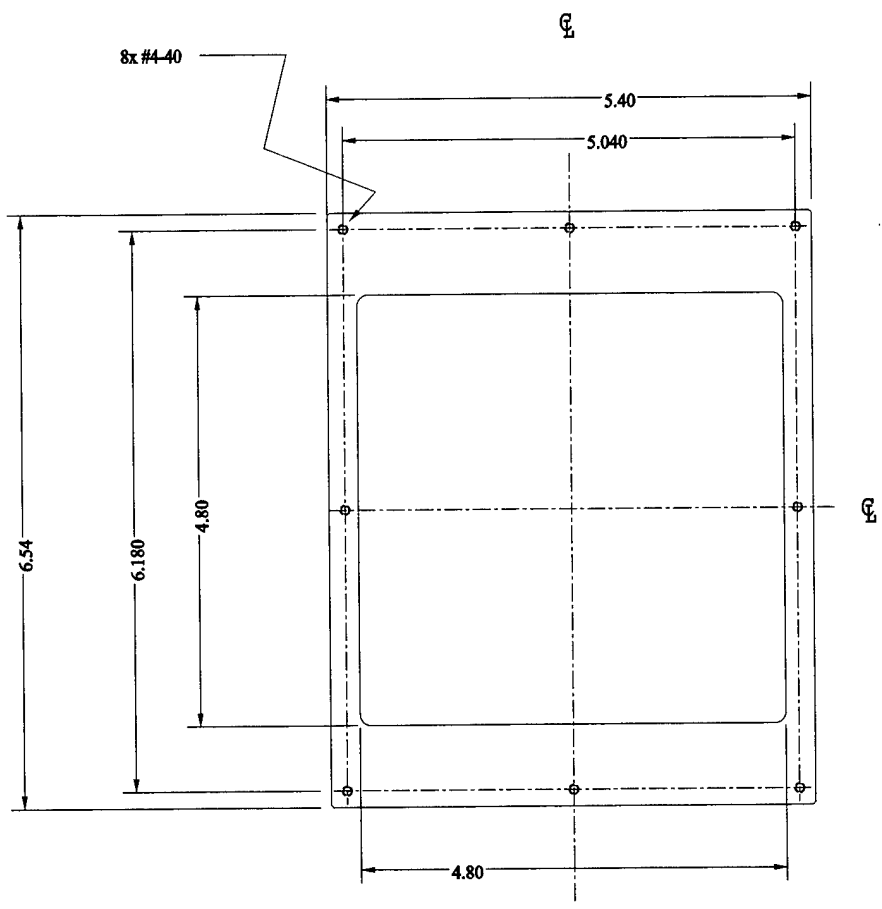

NOTES:

1. MATL: .188 AL ALLOY SHEET or PLATE
2. ALL FEATURES SYMMETRICAL ABOUT C/L's UNLESS OTHERWISE NOTED.
3. .13 R MAX FOR INSIDE CORNERS; BREAK EDGES AND CORNERS.
4. SHEAR CUT OKAY.

TOL: .XXX ± .005 .XX ± .01 .X ± — ANGLES ± 1°	<b>FAN BACK PANEL</b>	
	9/1/99	SK MRP064_A
F/N.SK064_A_FAN_BK_PNL.XDW		

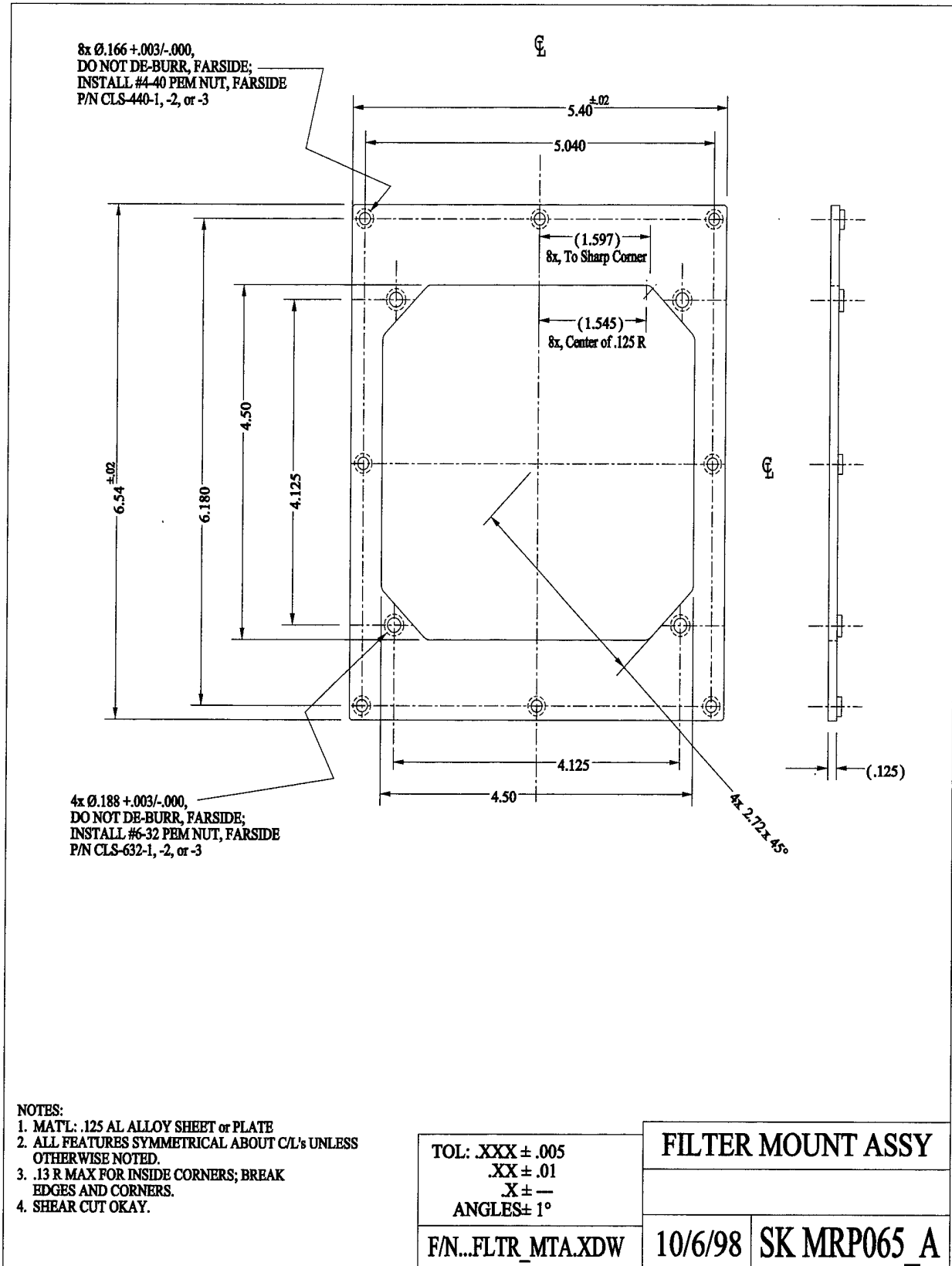

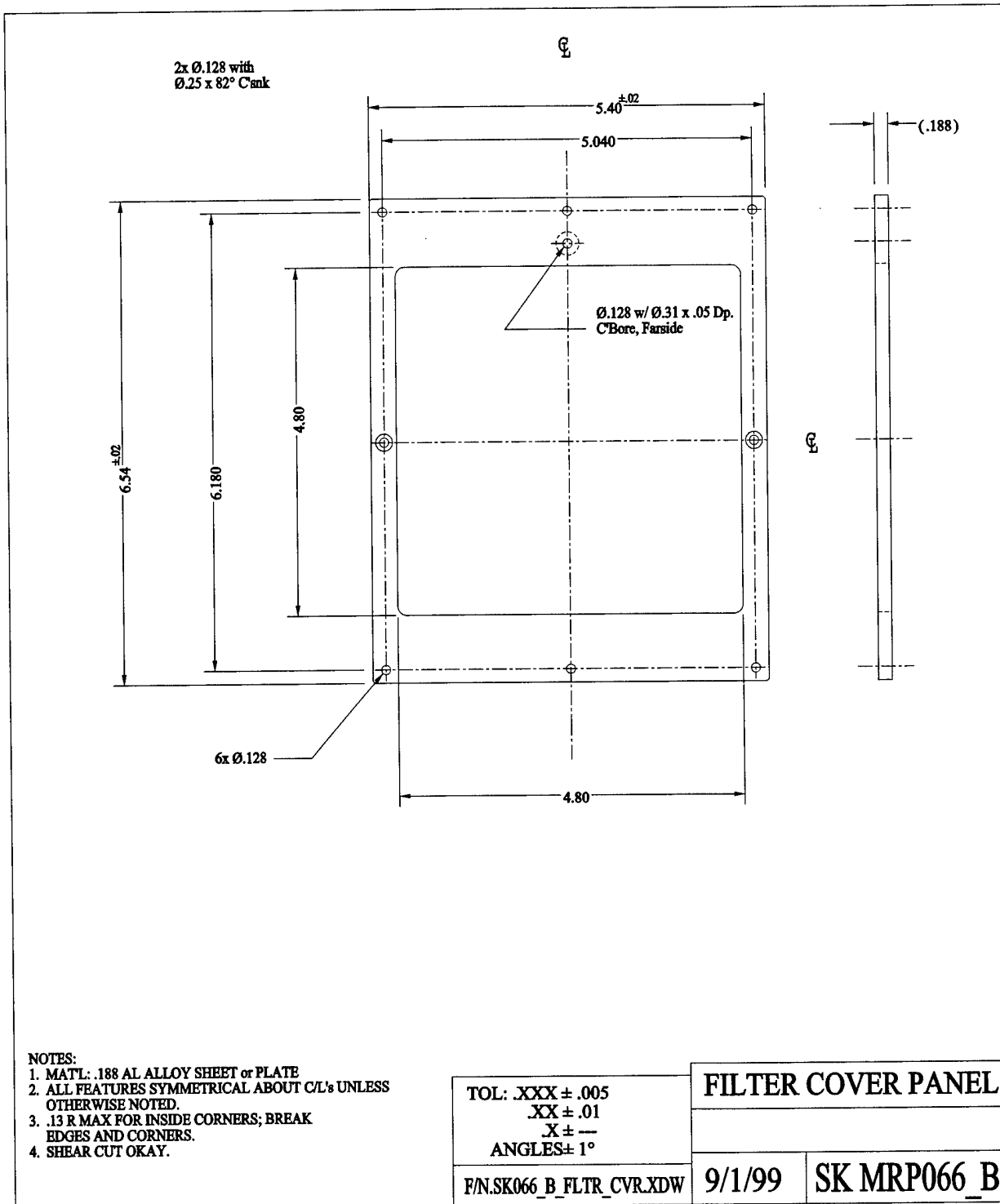

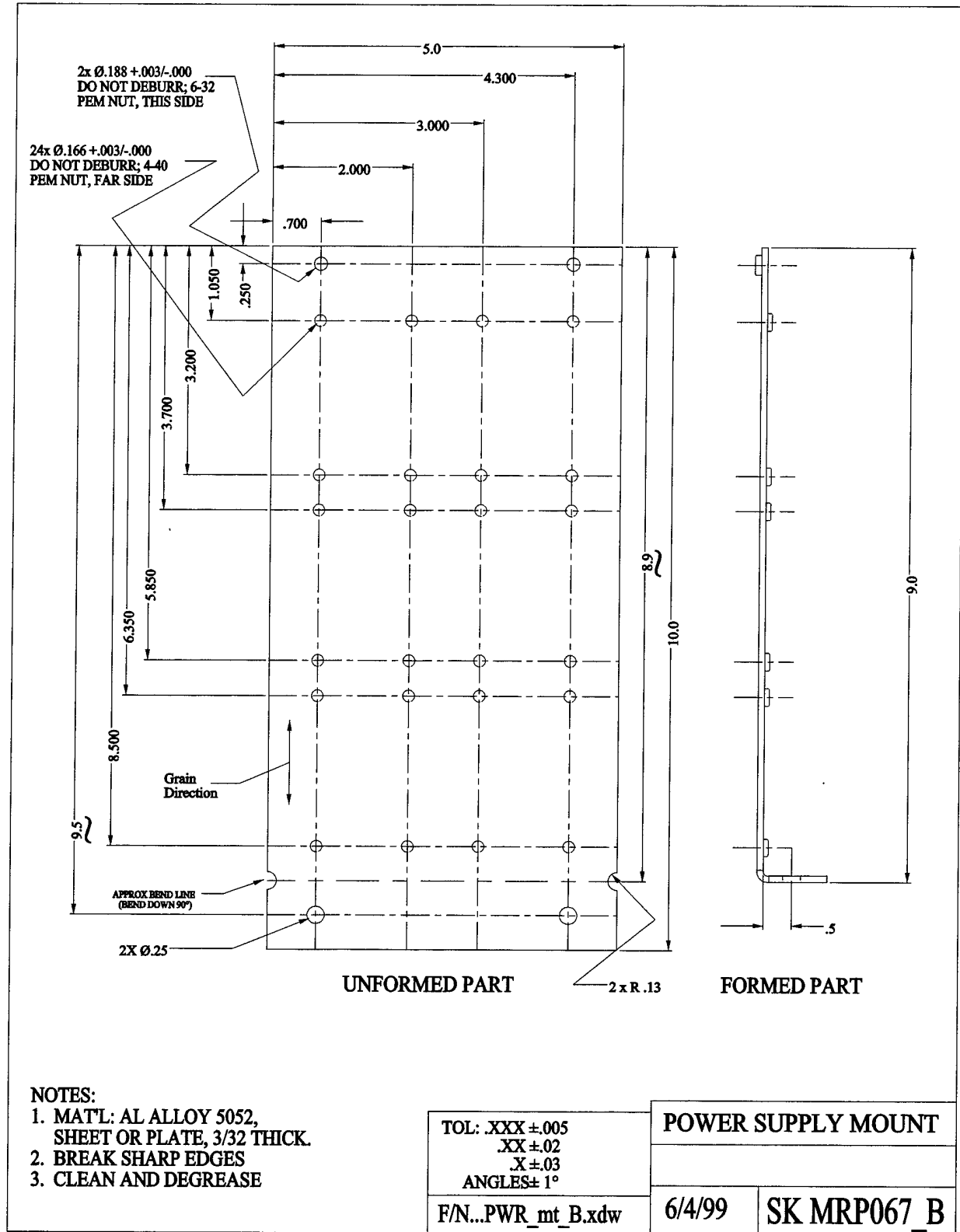

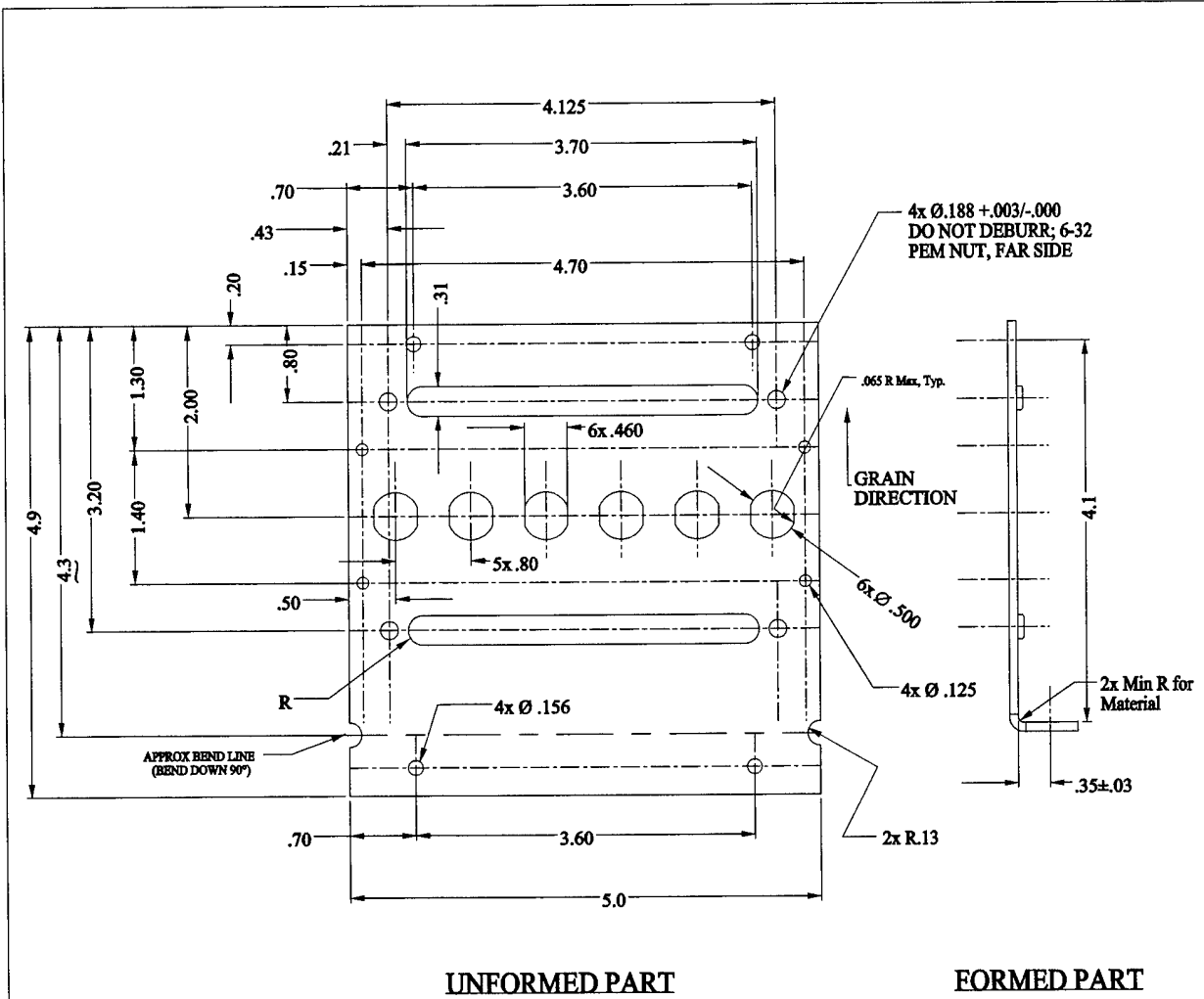

**NOTES:**

1. MAT'L: AL ALLOY 5052, SHEET OR PLATE, 3/32 THICK.
2. BREAK SHARP EDGES
3. CLEAN AND DEGREASE

TOL: .XXX±.005 .XX±.02 X±.03 ANGLES±1°	<b>TERMINAL BLOCK &amp; FUSE PLATE</b>	
	F/N...TRMFUS_C.xdw	5/24/99

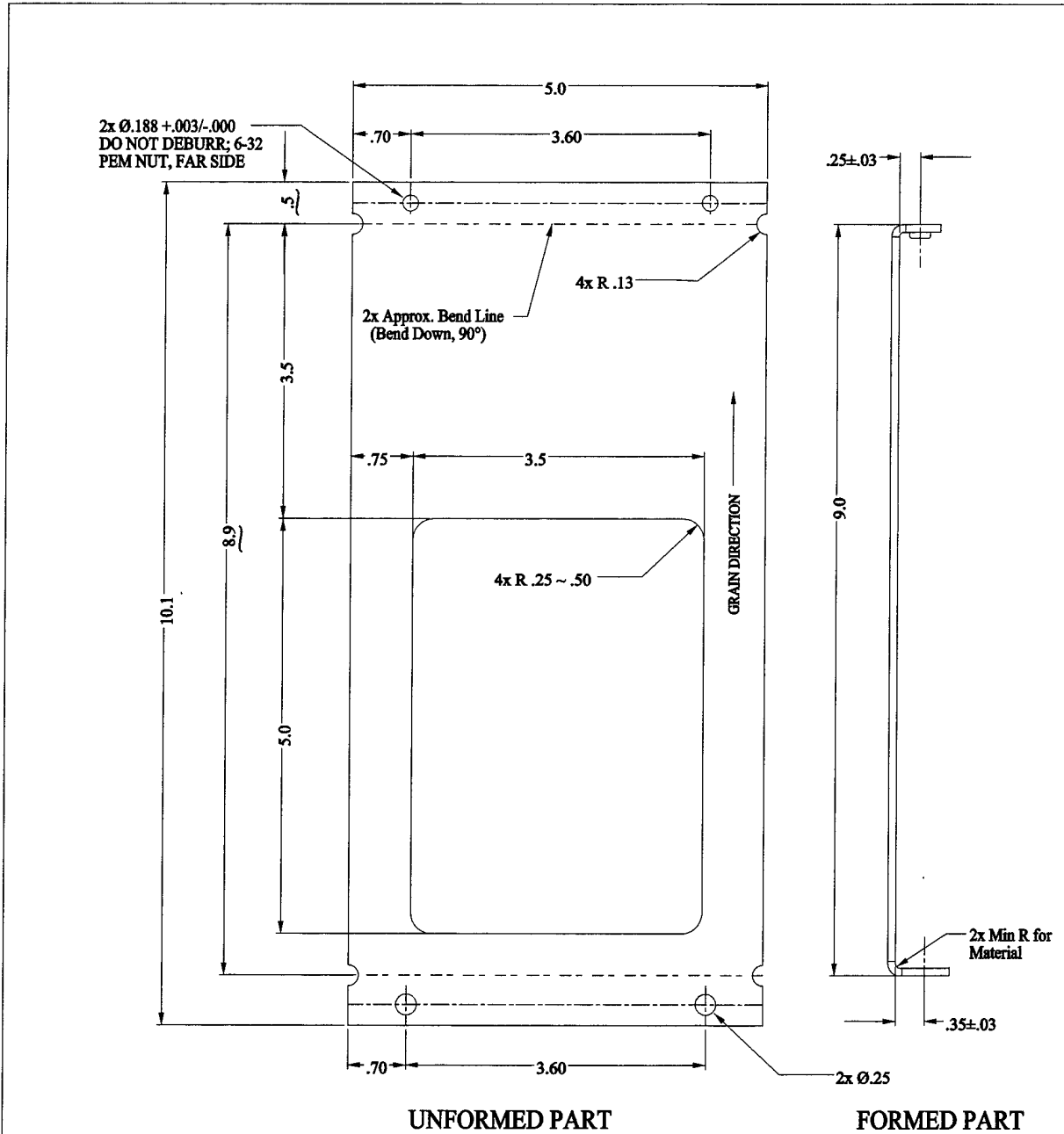

- NOTES:
1. MATL: AL ALLOY 5052, SHEET OR PLATE, 3/32 THICK.
  2. BREAK SHARP EDGES
  3. CLEAN AND DEGREASE

TOL: .XXX ± .005 .XX ± .02 .X ± .03 ANGLES ± 1°	FUSE/TERMINAL BLOCK SUPPORT BRACKET	
F/N...FUS_BRKT_A.xdw		

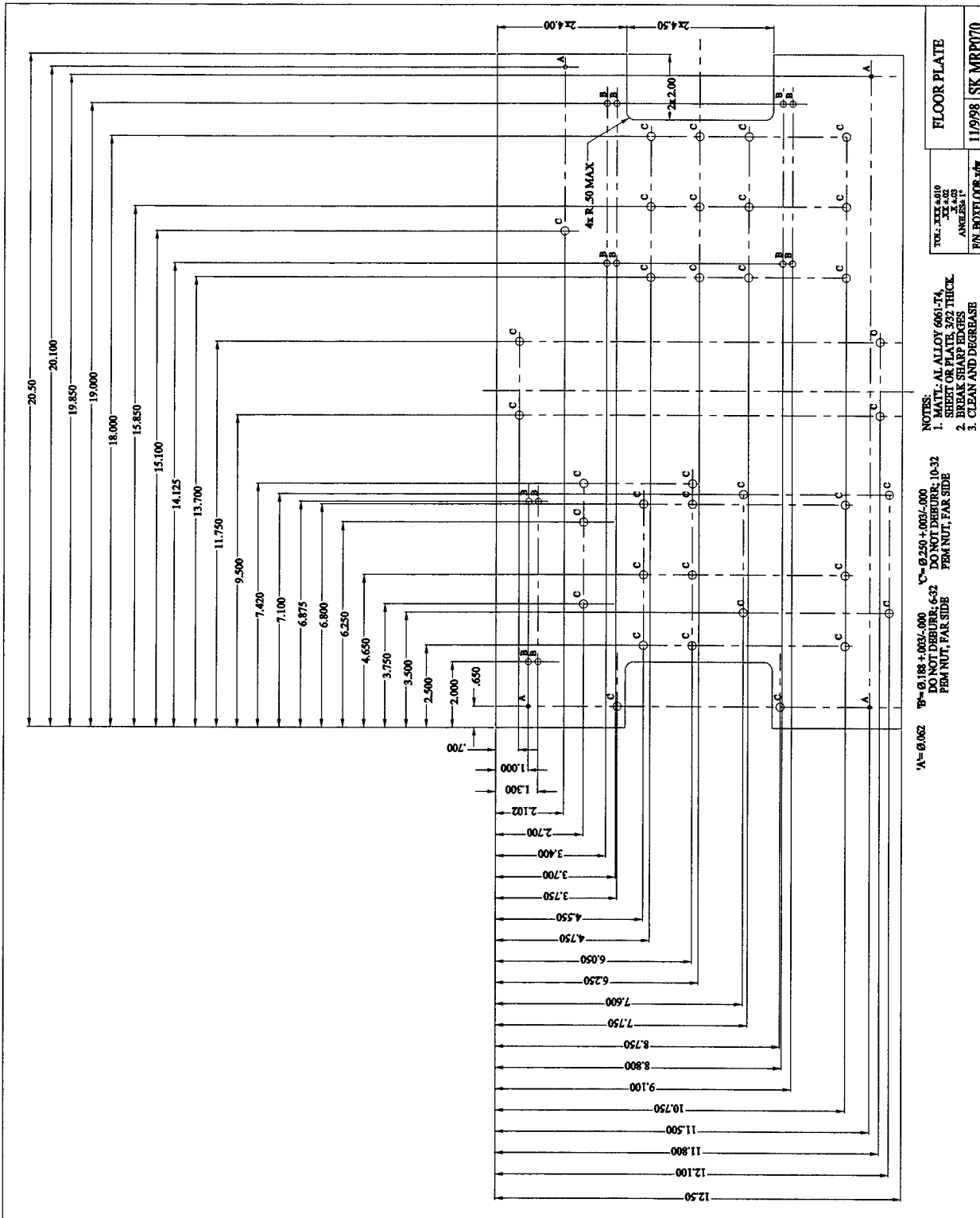

**FLOOR PLATE**  
 TOL. XXX.010  
 XX.402  
 ANGLES 1°  
 FN. BOYFLOOR.dwg  
 11/9/98 SK.MRP070

NOTES:  
 1. MATL: AL ALLOY 6061-T4  
 SHEET OR PLATE, 3/32 THICK.  
 2. BREAK SHARP EDGES  
 3. CLEAN AND DEGREASE

'A' = 0.062    'B' = 0.188 + 0.031/-0.000    'C' = 0.250 + 0.031/-0.000  
 DO NOT DEBURR; 6-32    DO NOT DEBURR; 10-32  
 FEM NUT, FAR SIDE    FEM NUT, FAR SIDE

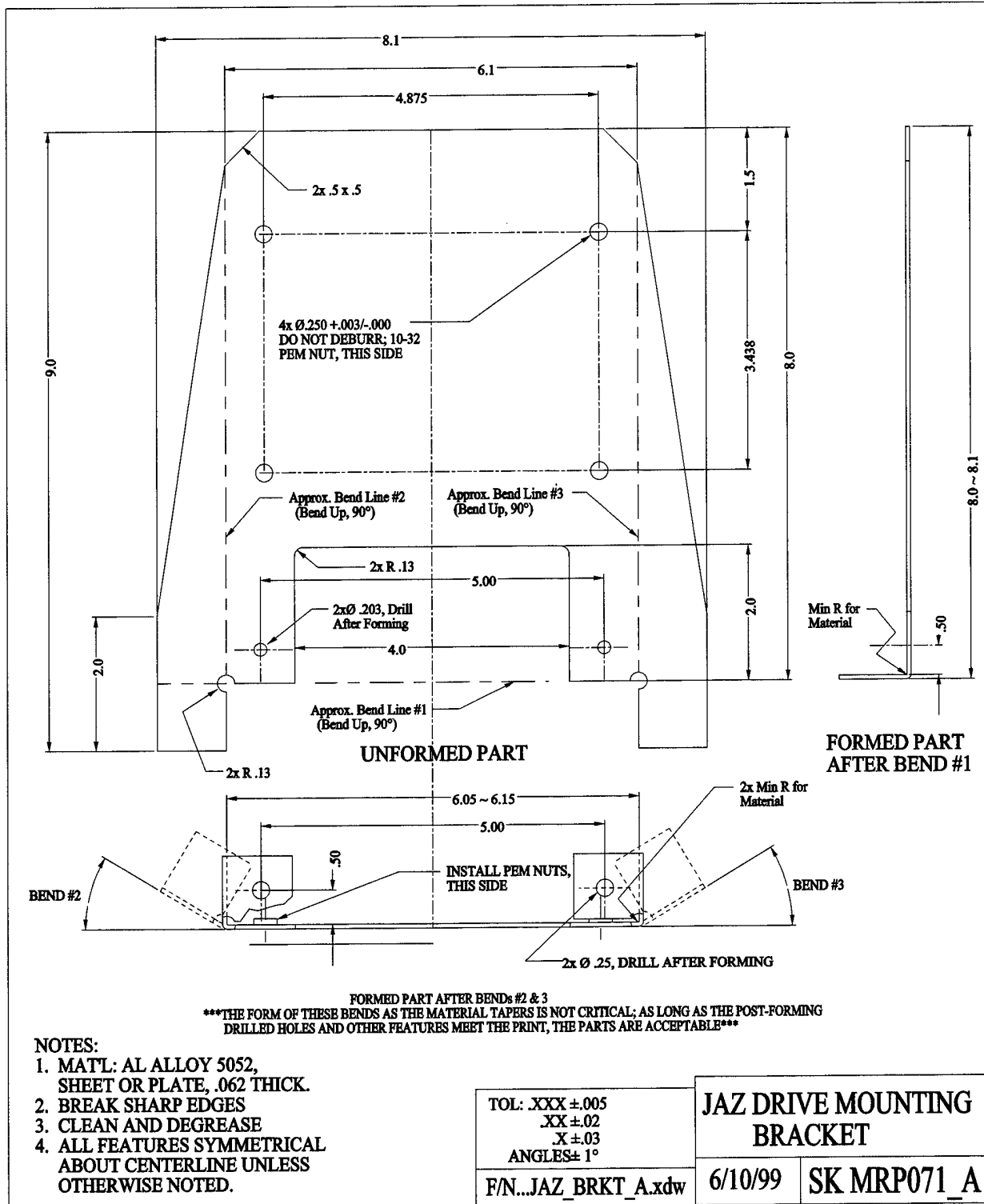

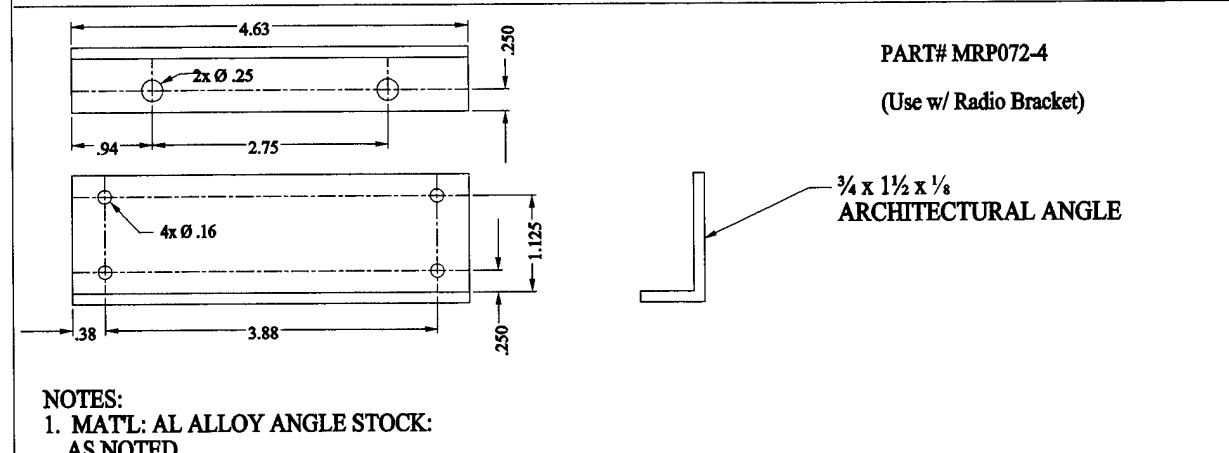
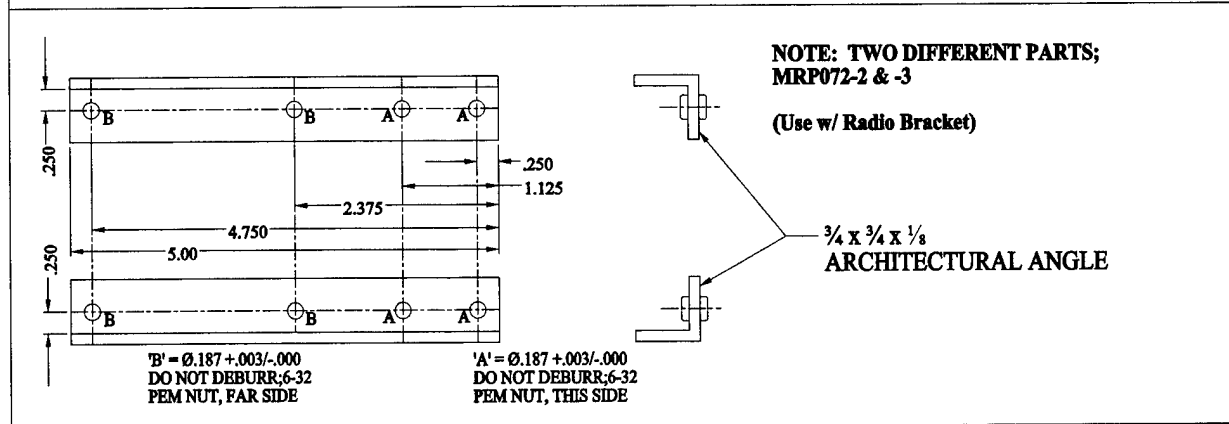
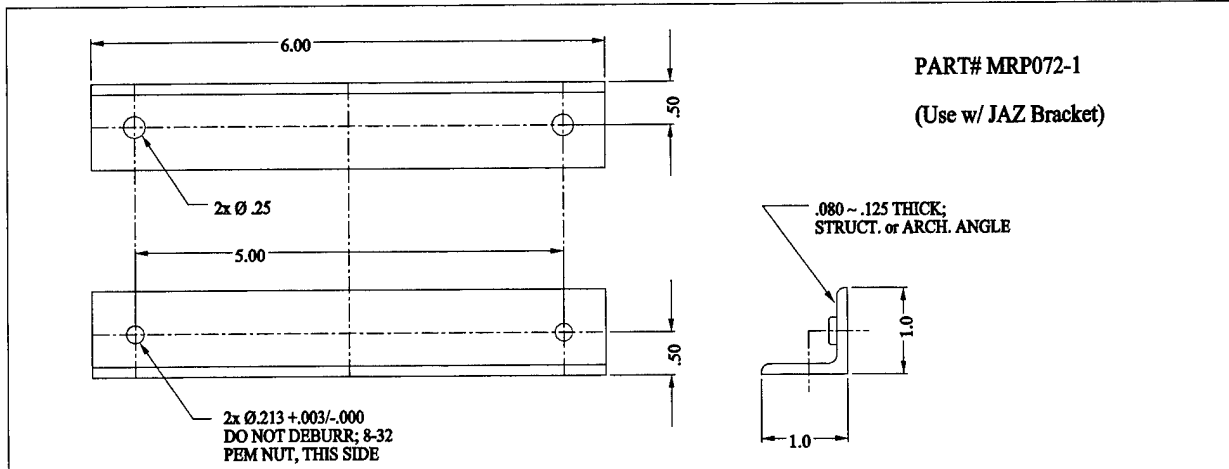

- NOTES:**
1. MATL: AL ALLOY ANGLE STOCK:  
AS NOTED.
  2. BREAK SHARP EDGES
  3. CLEAN AND DEGREASE

TOL: .XXX ±.005  
.XX ±.02  
.X ±.03  
ANGLES ± 1°

**ANGLE BRACKETS**

F/N...BAS\_BRKT.xdw

6/10/98

SK MRP072

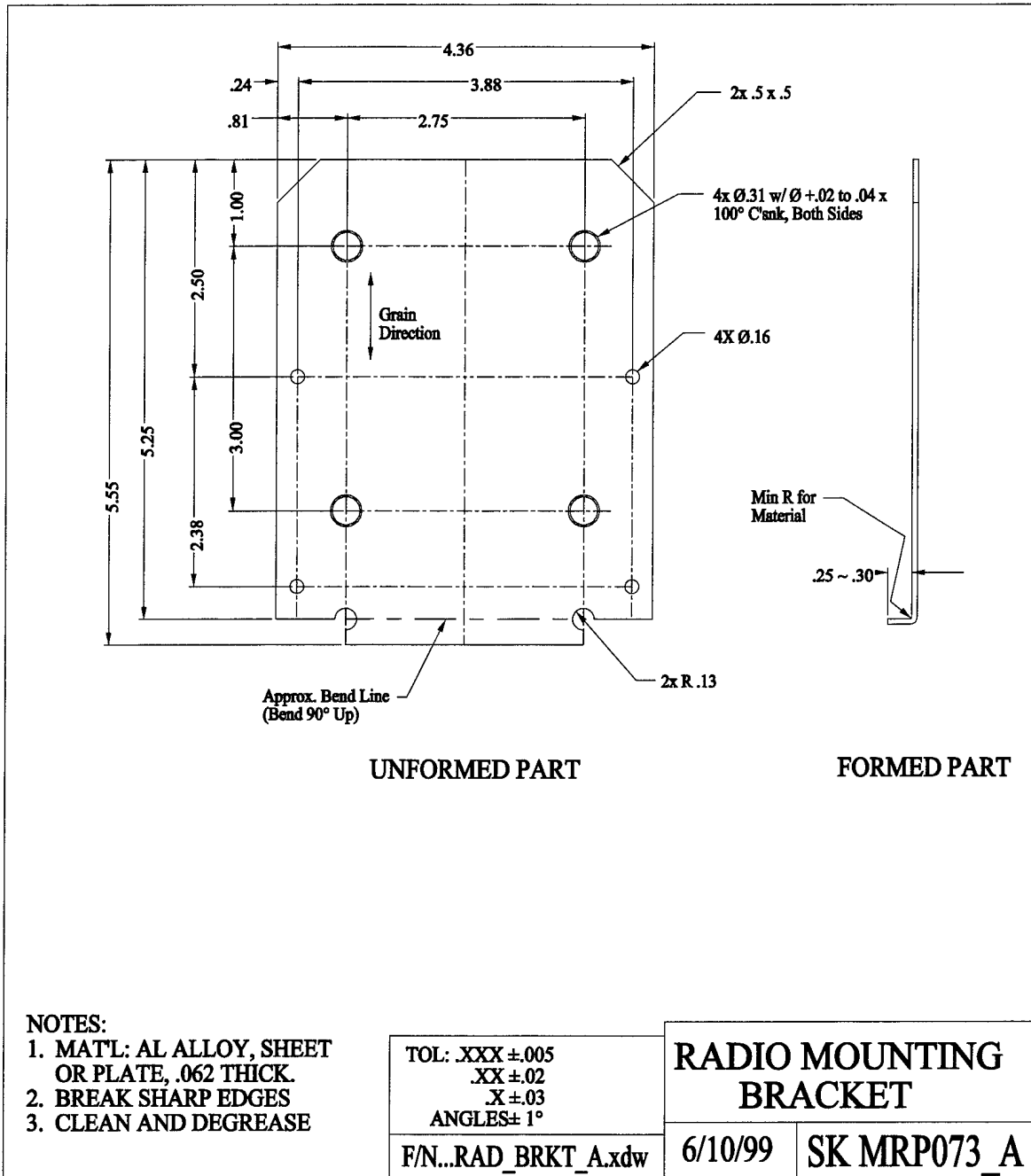

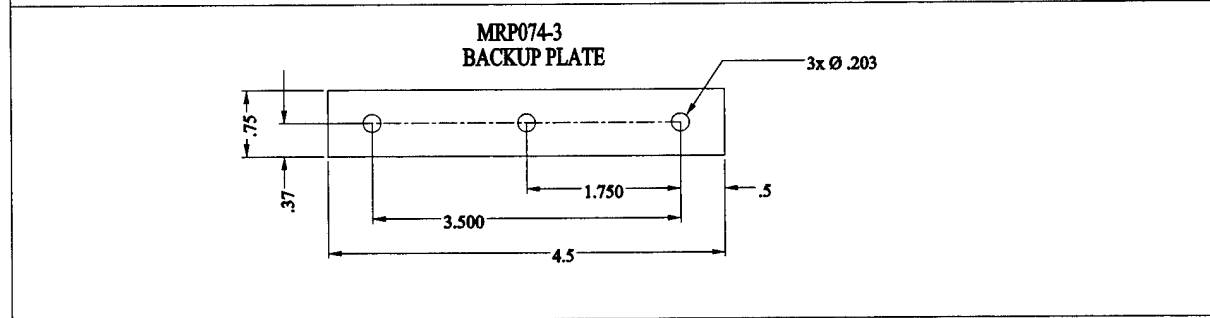
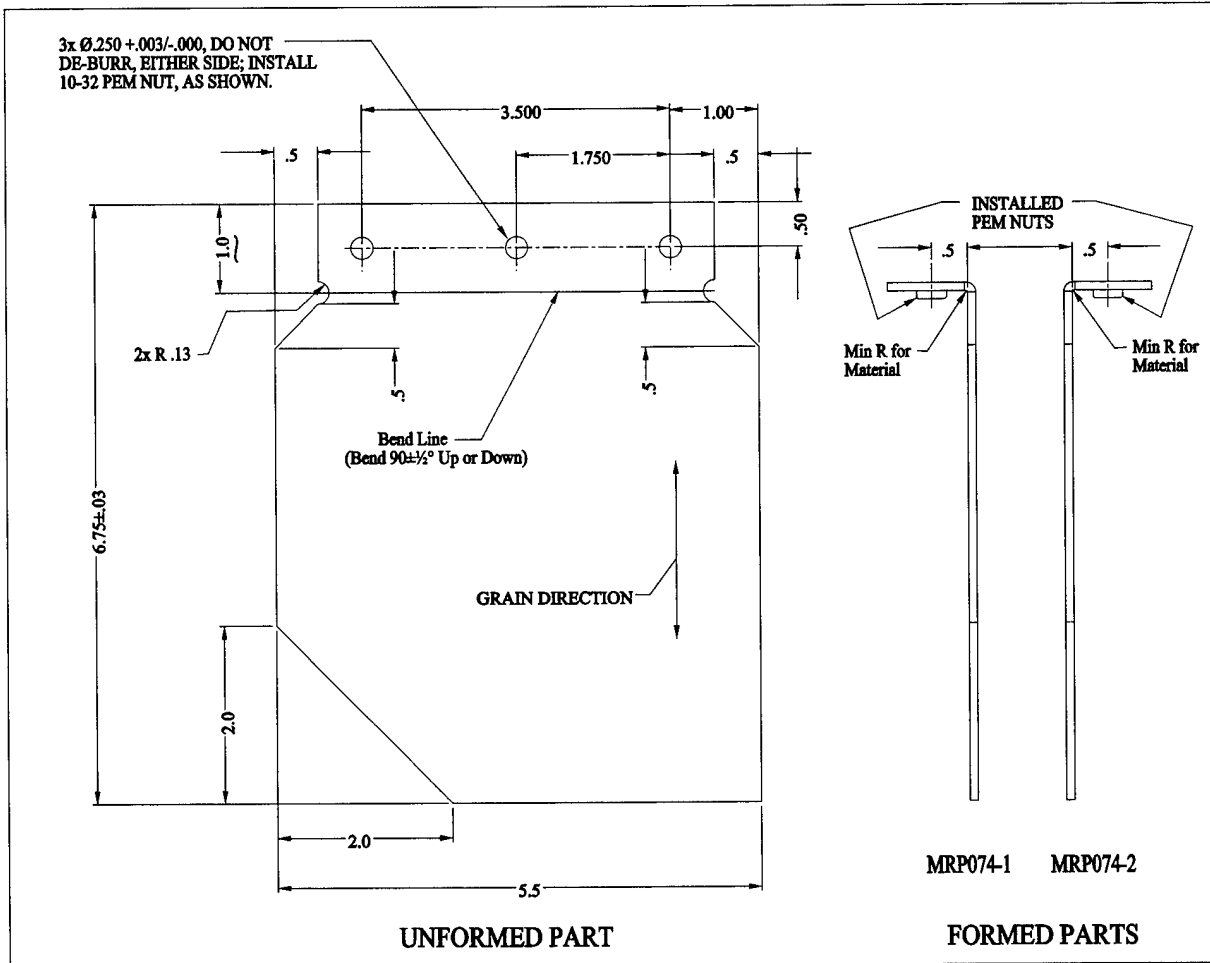

NOTES:

1. MAT'L: AL ALLOY 5052, SHEET OR PLATE, 3/32" THICK.
2. BREAK SHARP EDGES
3. CLEAN AND DEGREASE
4. SHEAR CUT OK.

TOL: .XXX $\pm .005$ .XX $\pm .02$ .X $\pm .03$ ANGLES $\pm \frac{1}{2}^\circ$
F/N...BOXBRKT_A.xdw

BOX FLOOR MOUNTING BRACKETS & BACKUP PLATE	
6/4/99	SK MRP074_A

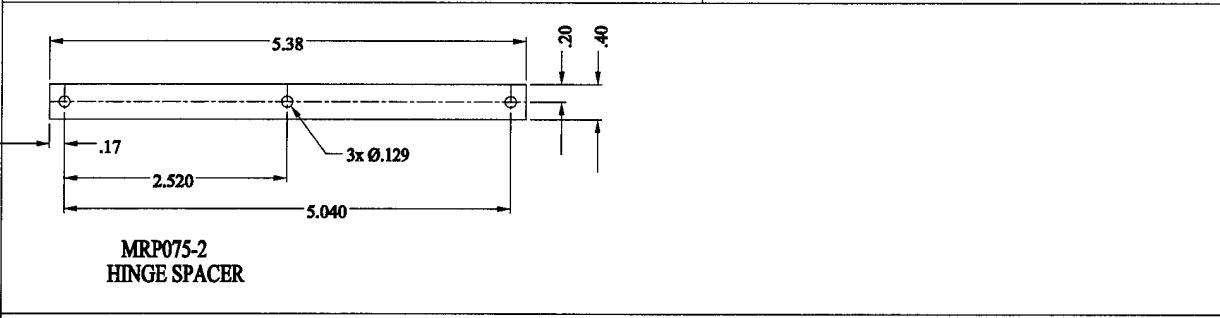
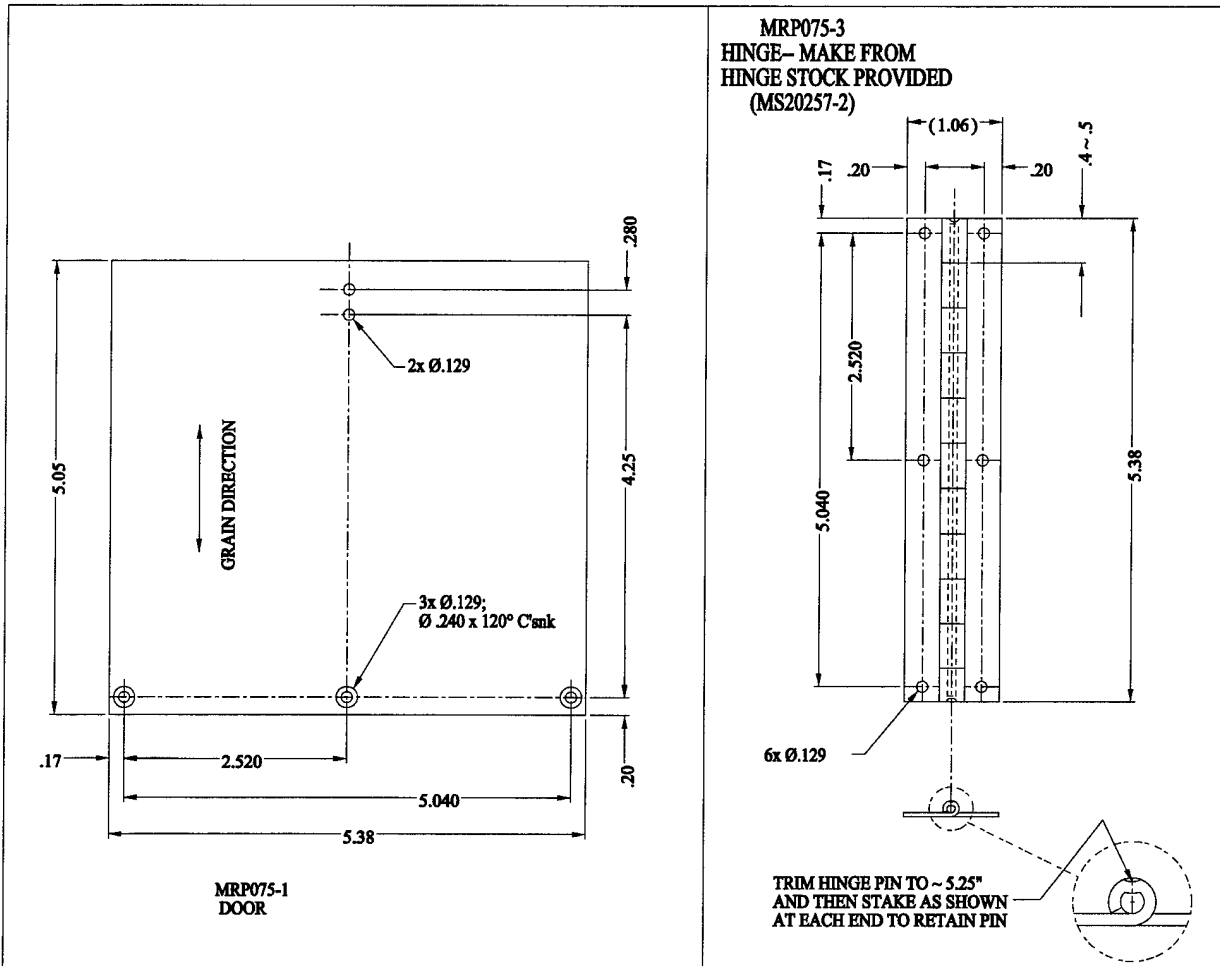

- NOTES:**
1. **MATL: AL ALLOY 6061-T4, SHEET OR PLATE, 1/16" THICK.**
  2. **BREAK SHARP EDGES**
  3. **CLEAN AND DEGREASE**

TOL: .XXX ±.005 XX ±.02 X ±.03 ANGLES ± 1°
F/N...FAN_DR_A.xdw

<b>FAN / EXHAUST HINGED DOOR</b>	
6/16/99	SK MRP075_A

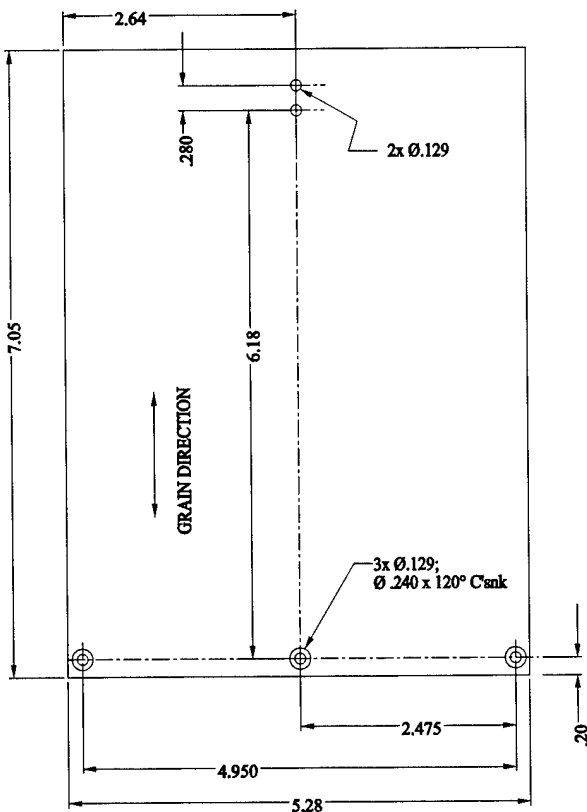

MRP076-1  
END PANEL DOOR

MRP076-3  
HINGE - MAKE FROM  
HINGE STOCK PROVIDED  
(MS20257-2)

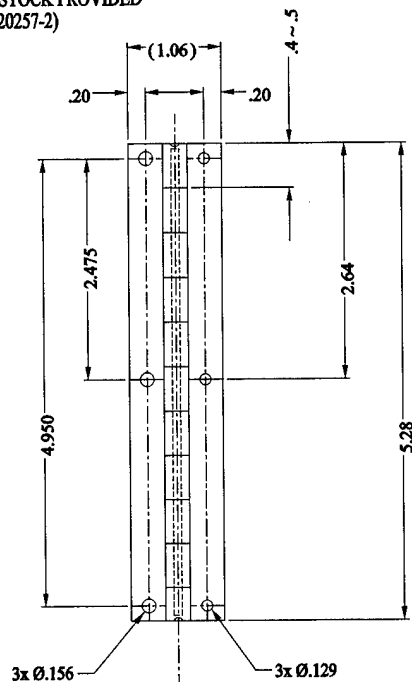

TRIM HINGE PIN TO ~5.15"  
AND THEN STAKE AS SHOWN  
AT EACH END TO RETAIN PIN

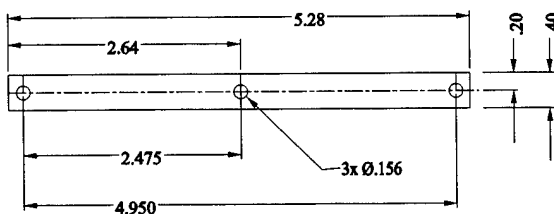

MRP076-2  
HINGE SPACER

NOTES:

1. MAT'L: AL ALLOY 6061-T4,  
SHEET OR PLATE, 1/16" THICK.
2. BREAK SHARP EDGES
3. CLEAN AND DEGREASE
4. SHEAR CUT OKAY

TOL: .XXX ±.005  
.XX ±.02  
.X ±.03  
ANGLES ± 1°

END PANEL  
HINGED DOOR

F/N..PANL\_DR\_A.xdw

6/16/99

SK MRP076\_A

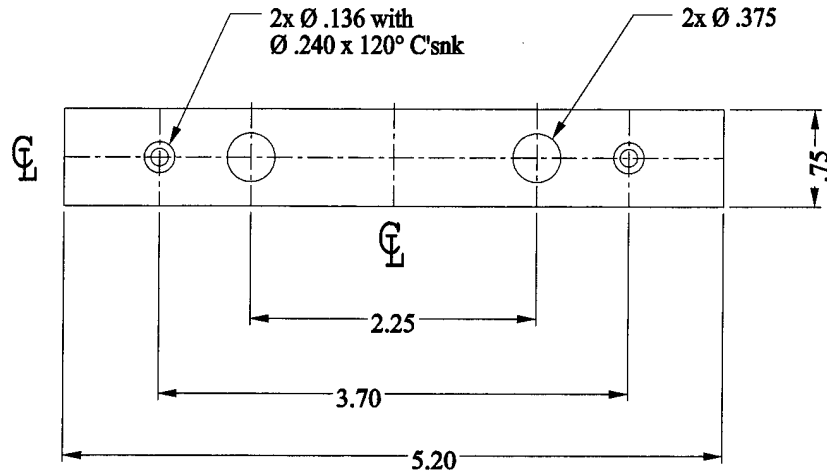

**NOTES:**

1. MAT'L: AL ALLOY, SHEET OR PLATE, 1/16" THICK.
2. BREAK SHARP EDGES
3. CLEAN AND DEGREASE
4. SHEAR CUT OKAY
5. FEATURES SYMMETRIC ABOUT CENTERLINE UNLESS OTHERWISE NOTED.

TOL: .XXX ±.005 .XX ±.02 .X ±.03 ANGLES± 1°	<h2>PC SPACER</h2>	
	11/18/98	SK MRP077
F/N...PC_SPACR.xdw		

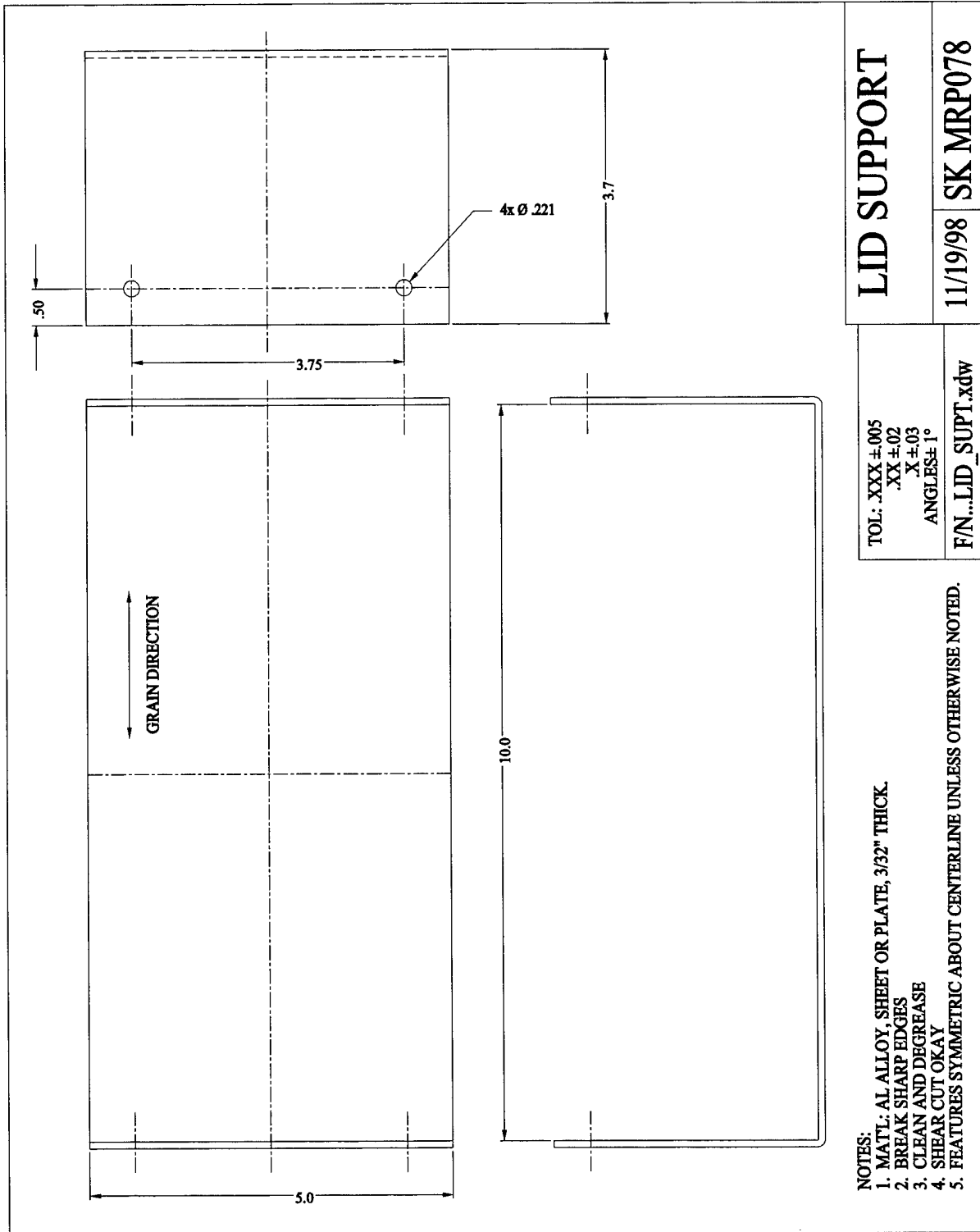

**LID SUPPORT**

TOL: .XXX ±.005  
 .XX ±.02  
 X ±.03  
 ANGLES ± 1°

F/N: LID\_SUPT\_.xdw

**NOTES:**

1. MATL: AL ALLOY SHEET OR PLATE, 3/32" THICK.
2. BREAK SHARP EDGES
3. CLEAN AND DEGREASE
4. SHEAR CUT OKAY
5. FEATURES SYMMETRIC ABOUT CENTERLINE UNLESS OTHERWISE NOTED.

11/19/98 SK MRP078

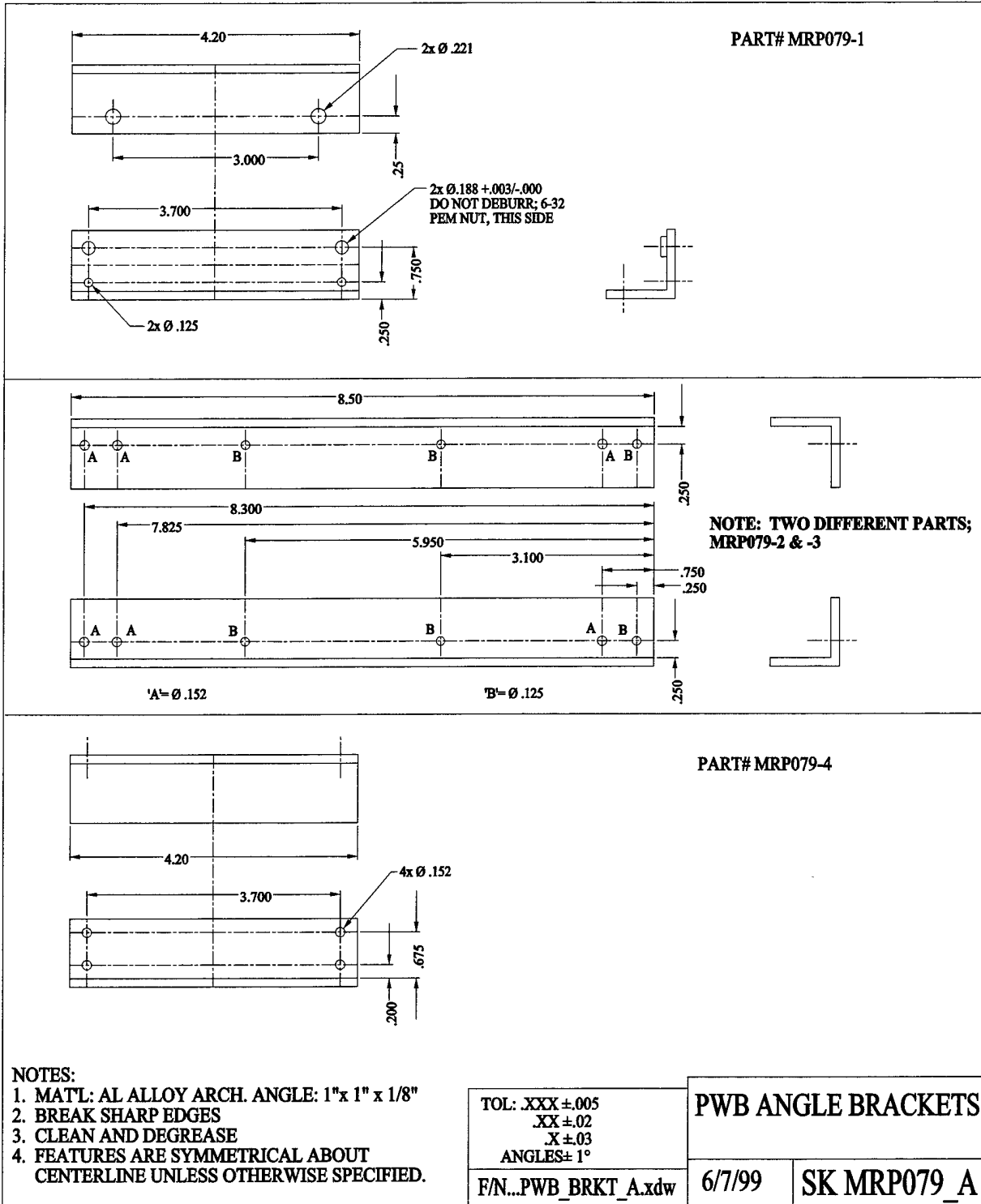

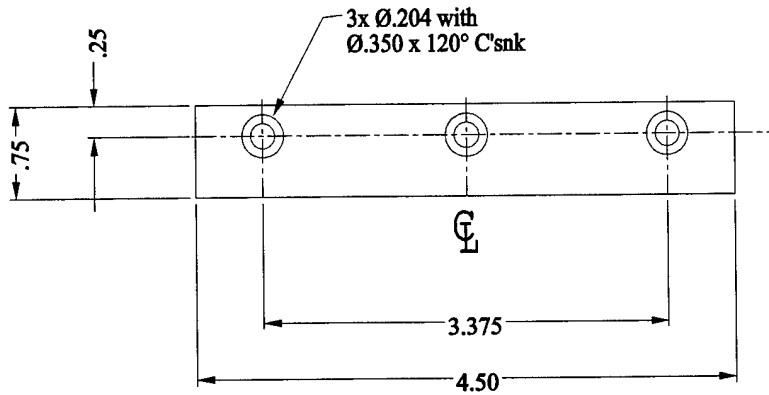

**NOTES:**

1. MAT'L: AL ALLOY, SHEET OR PLATE, 1/16" THICK.
2. BREAK SHARP EDGES
3. CLEAN AND DEGREASE
4. SHEAR CUT OKAY
5. FEATURES SYMMETRIC ABOUT CENTERLINE UNLESS OTHERWISE NOTED.

TOL: .XXX ±.005 .XX ±.02 .X ±.03 ANGLES ± 1°	<b>HANDLE BACKUP PLATE</b>	
	F/N:SK089_HANDLE_BACKUP	6/10/99 SK MRP089

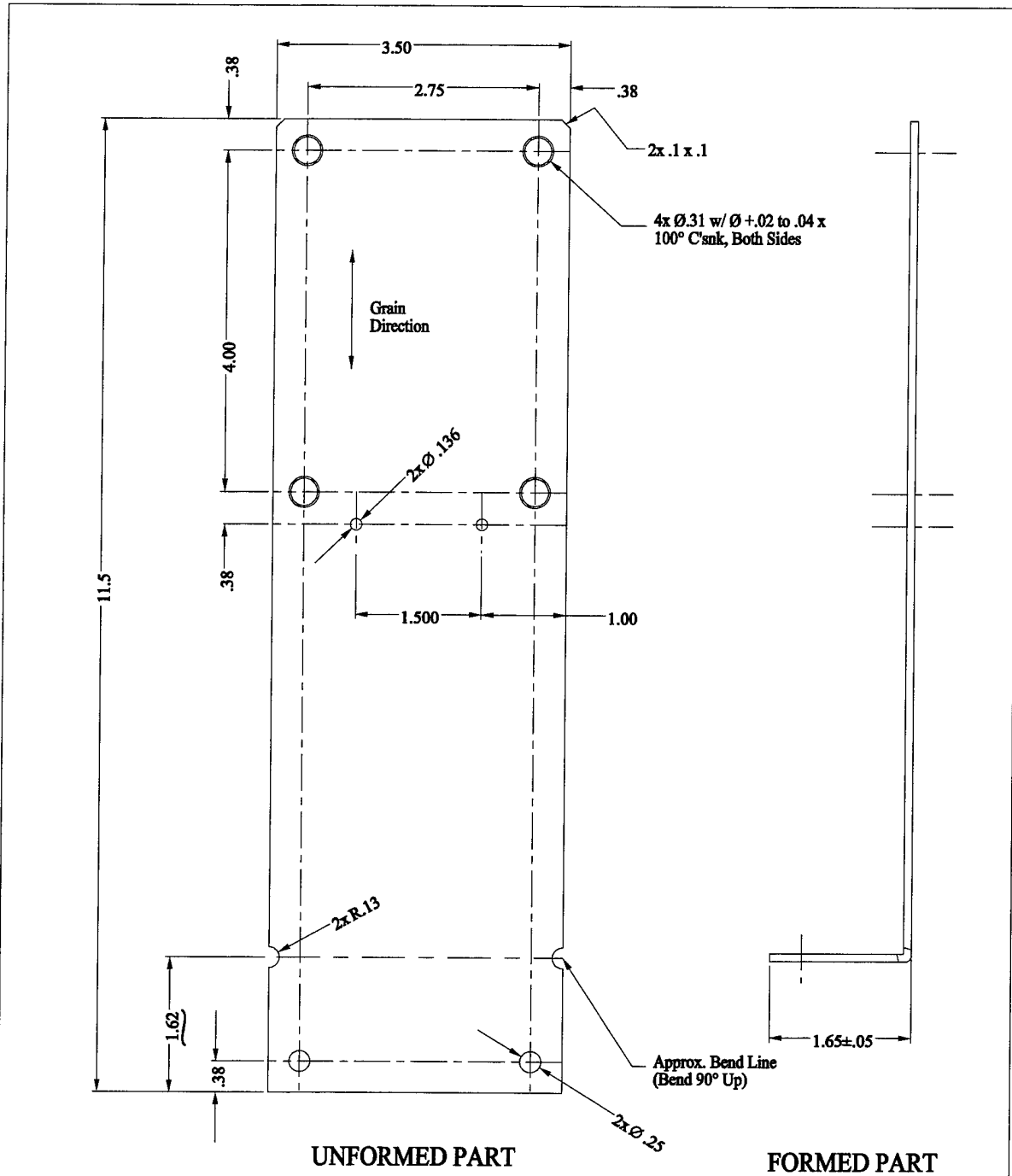

NOTES:

1. MAT'L: 5052 AL ALLOY, SHEET OR PLATE, 3/32" THICK.
2. SHEAR CUT OKAY
3. BREAK SHARP EDGES
4. CLEAN AND DEGREASE

TOL: .XXX ±.005 .XX ±.02 .X ±.03 ANGLES± 1°	<b>WIRELESS MOUNTING BRACKET</b>	
	8/27/99	<b>SK MRP090</b>

F/N:SK090\_WIRELESS\_BRKT.xdw

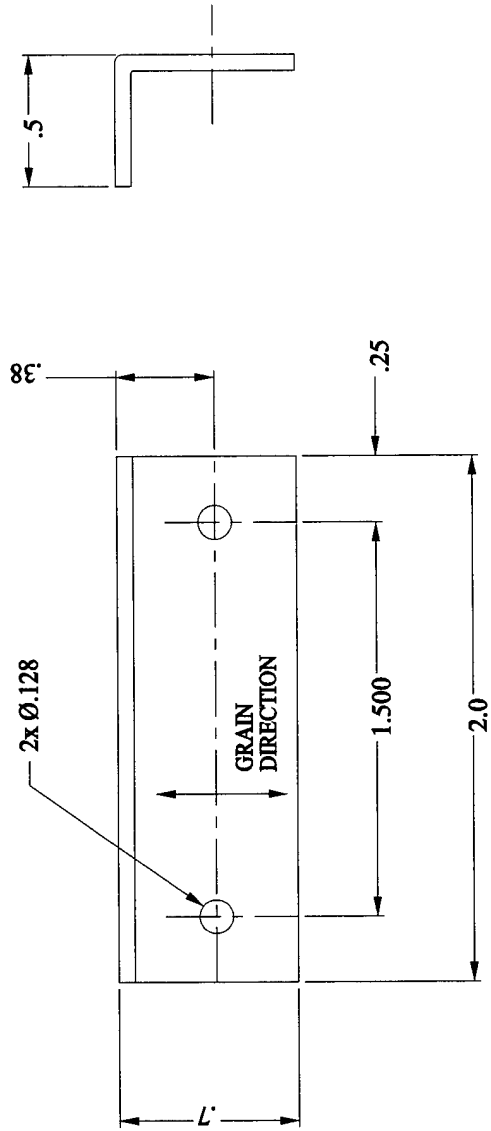

- NOTES:**
1. MAT'L: 5052 AL ALLOY, SHEET OR PLATE, 1/16" THICK.
  2. SHEAR CUT OKAY
  3. BREAK SHARP EDGES
  4. CLEAN AND DEGREASE

**WIRELESS SUPPORT  
BRACKET**

TOL: .XXX ±.005  
.XX ±.02  
.X ±.03  
ANGLES ± 1°

8/27/99 SK MRP091

FN:SK091\_WIRELESS\_SUPPORT.xdw

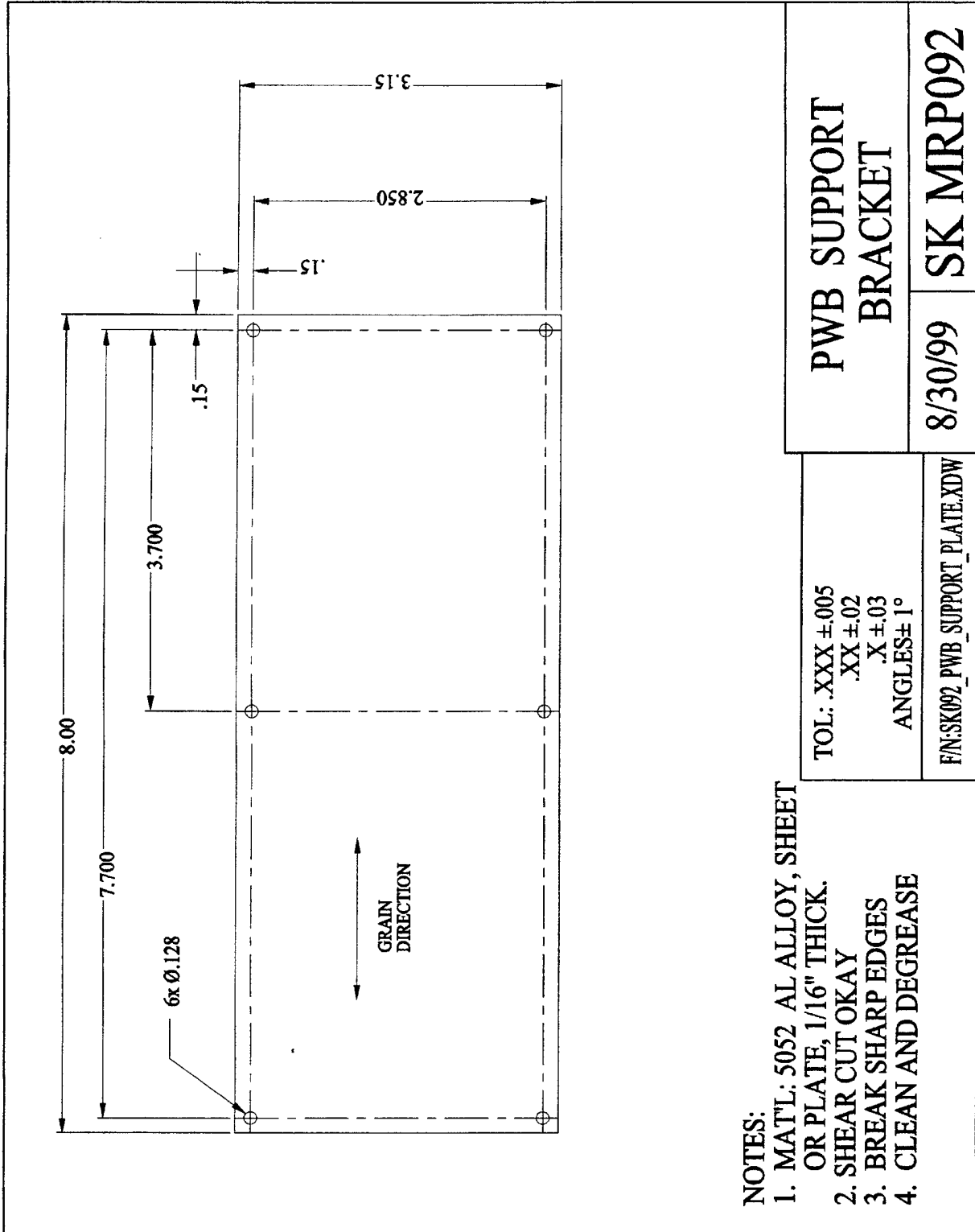

**NOTES:**

1. MAT'L: 5052 AL ALLOY, SHEET OR PLATE, 1/16" THICK.
2. SHEAR CUT OKAY
3. BREAK SHARP EDGES
4. CLEAN AND DEGREASE

TOL: .XXX ±.005  
 .XX ±.02  
 .X ±.03  
 ANGLES ± 1°

F/N:SK092\_PWB\_SUPPORT\_PLATE.XDW

**PWB SUPPORT BRACKET**

**8/30/99 SK MRP092**

## Distribution

Admnstr  
Defns Techl Info Ctr  
Attn DTIC-OCP  
8725 John J Kingman Rd Ste 0944  
FT Belvoir VA 22060-6218

Ofc of the Secy of Defns  
Attn ODDRE (R&AT)  
Attn OUSD(A&T)/ODDR&E(R) R J Trew  
The Pentagon  
Washington DC 20301-3080

AMCOM MRDEC  
Attn AMSMI-RD W C McCorkle  
Redstone Arsenal AL 35898-5240

Dir for MANPRINT  
Ofc of the Deputy Chief of Staff for Prsnl  
Attn J Hiller  
The Pentagon Rm 2C733  
Washington DC 20301-0300

SMC/CZA  
2435 Vela Way Ste 1613  
El Segundo CA 90245-5500

US Army ARDEC  
Attn AMSTA-AR-TD M Fisette  
Bldg 1  
Picatinny Arsenal NJ 07806-5000

US Army Info Sys Engrg Cmnd  
Attn AMSEL-IE-TD F Jenia  
FT Huachuca AZ 85613-5300

US Army Natick RDEC Acting Techl Dir  
Attn SBCN-T P Brandler  
Natick MA 01760-5002

US Army Simulation, Train, & Instrmntn  
Cmnd  
Attn AMSTI-CG M Macedonia  
12350 Research Parkway  
Orlando FL 32826-3726

US Army Soldier & Biol Chem Cmnd Dir of  
Rsrch & Techlgy Dirctr  
Attn SMCCR-RS I G Resnick  
Aberdeen Proving Ground MD 21010-5423

US Army Tank-Automtv Cmnd Rsrch, Dev, &  
Engrg Ctr  
Attn AMSTA-TR J Chapin  
Warren MI 48397-5000

US Army Train & Doctrine Cmnd Battle Lab  
Integration & Techl Dirctr  
Attn ATCD-B  
FT Monroe VA 23651-5850

US Army White Sands Missile Range  
Attn STEWS-IM-ITZ Techl Lib Br  
White Sands Missile Range NM 88002-5501

US Military Academy  
Mathematical Sci Ctr of Excellence  
Attn MDN-A LTC M D Phillips  
Dept of Mathematical Sci Thayer Hall  
West Point NY 10996-1786

Nav Surface Warfare Ctr  
Attn Code B07 J Pennella  
17320 Dahlgren Rd Bldg 1470 Rm 1101  
Dahlgren VA 22448-5100

DARPA  
Attn S Welby  
3701 N Fairfax Dr  
Arlington VA 22203-1714

Hicks & Associates Inc  
Attn G Singley III  
1710 Goodrich Dr Ste 1300  
McLean VA 22102

Palisades Inst for Rsrch Svc Inc  
Attn E Carr  
1745 Jefferson Davis Hwy Ste 500  
Arlington VA 22202-3402

## Distribution

US Army Rsrch Lab  
Attn AMSRL-CI-LP (305)  
Aberdeen Proving Ground MD 21005

Director  
US Army Rsrch Ofc  
Attn AMSRL-RO-D JCI Chang  
Attn AMSRL-RO-EN W D Bach  
PO Box 12211  
Research Triangle Park NC 27709

US Army Rsrch Lab  
Attn AMSRL-CI-AI-R Mail & Records Mgmt  
Attn AMSRL-CI-AP Techl Pub (3 copies)  
Attn AMSRL-CI-LL Techl Lib (3 copies)  
Attn AMSRL-DD J M Miller  
Attn AMSRL-SE-SA A Ladas  
Attn AMSRL-SE-SA B Mays  
Attn AMSRL-SE-SA L Sim  
Attn AMSRL-SE-SA M Probst (3 copies)  
Attn AMSRL-SE-SA N Srour  
Attn AMSRL-SE-SA S Tenney  
Attn AMSRL-SE-SE J Hopkins  
Adelphi MD 20783-1197

# REPORT DOCUMENTATION PAGE

Form Approved  
OMB No. 0704-0188

Public reporting burden for this collection of information is estimated to average 1 hour per response, including the time for reviewing instructions, searching existing data sources, gathering and maintaining the data needed, and completing and reviewing the collection of information. Send comments regarding this burden estimate or any other aspect of this collection of information, including suggestions for reducing this burden, to Washington Headquarters Services, Directorate for Information Operations and Reports, 1215 Jefferson Davis Highway, Suite 1204, Arlington, VA 22202-4302, and to the Office of Management and Budget, Paperwork Reduction Project (0704-0188), Washington, DC 20503.

1. AGENCY USE ONLY (Leave blank)		2. REPORT DATE July 2000	3. REPORT TYPE AND DATES COVERED Final, 6/98-8/99	
4. TITLE AND SUBTITLE Mechanical Design Report for the Main Control Unit of a New Acoustic Sensor Unit			5. FUNDING NUMBERS DA PR: AH54 PE: 61104A	
6. AUTHOR(S) Mark Probst				
7. PERFORMING ORGANIZATION NAME(S) AND ADDRESS(ES) U.S. Army Research Laboratory Attn: AMSRL-SE-SA email: mprobst@arl.mil 2800 Powder Mill Road Adelphi, MD 20783-1197			8. PERFORMING ORGANIZATION REPORT NUMBER ARL-MR-467	
9. SPONSORING/MONITORING AGENCY NAME(S) AND ADDRESS(ES) U.S. Army Research Laboratory 2800 Powder Mill Road Adelphi, MD 20783-1197			10. SPONSORING/MONITORING AGENCY REPORT NUMBER	
11. SUPPLEMENTARY NOTES ARL PR: 9NE4T3 AMS code: 611104.H54				
12a. DISTRIBUTION/AVAILABILITY STATEMENT Approved for public release; distribution unlimited.			12b. DISTRIBUTION CODE	
13. ABSTRACT (Maximum 200 words) This report documents the mechanical design and fabrication of the main control unit (MCU), one component of the Army Research Laboratory's recent upgrade of its signal-processing field hardware used in data collection and algorithm evaluation. The overall upgrade includes six new acoustic sensor units, each of which has one MCU and two analog signal conditioning boxes (ASCBs). Two appendices provide fabrication and assembly details of the MCU and drawings of the custom-built hardware used to assemble the MCU.				
14. SUBJECT TERMS Main control unit, ruggedized shipping container, commercial off-the-shelf			15. NUMBER OF PAGES 60	
			16. PRICE CODE	
17. SECURITY CLASSIFICATION OF REPORT Unclassified	18. SECURITY CLASSIFICATION OF THIS PAGE Unclassified	19. SECURITY CLASSIFICATION OF ABSTRACT Unclassified	20. LIMITATION OF ABSTRACT UL	