

Stress Analysis of a Tuner for an Electromagnetic Reverberation Chamber

Frank Weeks

DSTO-TN-0272

DISTRIBUTION STATEMENT A
Approved for Public Release
Distribution Unlimited

DTIC QUALITY INSPECTED 4
20000822 119

Stress Analyses of a Tuner for an Electromagnetic Reverberation Chamber

Frank Weeks

Air Operations Division
Aeronautical and Maritime Research Laboratory

DSTO-TN-0272

ABSTRACT

Structural analyses of a tuner for a large electromagnetic reverberation chamber are presented in this note. The analyses cover drive motor, highly stressed welds of the paddle assembly, torque in drive shafts, and weld fatigue life. The analyses have been conducted for normal operating conditions as well as for a variety of possible overload conditions. Recommendations for minor modifications are made, including the installation of a safety collar.

RELEASE LIMITATION

Approved for public release

DEPARTMENT OF DEFENCE
DEFENCE SCIENCE & TECHNOLOGY ORGANISATION

DSTO

AQF00-11-3099

Published by

*DSTO Aeronautical and Maritime Research Laboratory
PO Box 4331
Melbourne Victoria 3001 Australia*

*Telephone: (03) 9626 7000
Fax: (03) 9626 7999
© Commonwealth of Australia 2000
AR-011-423
February 2000*

APPROVED FOR PUBLIC RELEASE

Stress Analyses of a Tuner for an Electromagnetic Reverberation Chamber

Executive Summary

The tuner assembly used in the Defence Science Technology Organisation (DSTO) Electromagnetic Reverberation Chamber has been analysed for structural soundness. It was found to be structurally sound under normal operating conditions. However, when analysed for a variety of overload fault conditions the structure was found to have lower than desirable safety factors. A failure could result in damage to the tuner assembly and possibly to the equipment under test.

The installation of several strengthening webs, a safety collar and load shear key are therefore recommended. In addition, the more highly stressed welds have been analysed for fatigue failure and found to be safe under normal operating conditions. A table in the summary shows individual case safety factors and, where applicable, the recommended modifications.

Contents

1. INTRODUCTION	1
2. OPERATING PARAMETERS.....	1
2.1 Constructional requirements of the tuner paddles	1
2.2 Modes of operation.....	1
2.2.1 Stepping mode.....	1
2.2.2 Continuous rotation	2
3. MAJOR PARTS OF TUNER.....	2
4. DRIVE MOTOR AND GEARBOX SELECTION	4
4.1.1 Tuner inertia	4
4.1.2 Electric drive motor and gear box ratio selection	4
5. OPERATING CONDITIONS ANALYSED.....	4
5.1 Welds.....	4
5.1.1 Modes of operation analysed.....	4
5.2 Torque analysis	5
5.3 Additional analyses.....	5
6. WELDS ANALYSED.....	5
6.1 Weld stress at the root of the hub and shaft	5
6.1.1 Case 1: Normal operation.....	5
6.1.2 Case 2: Paddle jams while the drive motor is in operation	6
6.1.3 Case 3: Control card requests a sudden stop of the motor	6
6.1.4 Case 4: Stress in welds due to the weight of the paddle.....	6
6.2 Weld stress between the spar mounting plate and the paddle main spar	7
6.2.1 Case 1: Normal running mode	7
6.2.2 Case 2: Paddle jams while the motor is in operation	7
6.2.3 Case 3: Control card requests a sudden stop of the motor	7
6.2.4 Case 4: Load on weld due to the weight of the paddle.....	7
6.3 Weld stress on 'U' channel paddle structure.....	8
6.4 Stress on the paddle spar cross section.....	8
7. TORQUE CALCULATIONS	8
7.1 Torque on the paddle flange welds, 100° paddle at 40°.....	8
7.2 Torsional loads between the gearbox main drive shaft and the drive flange9	
7.3 Torsional load on the 82mm diameter main gearbox shaft	9
7.4 Torsional load on the tuner 150mm by 150mm main shaft.....	9
8. SHEAR STRENGTH OF THE DRIVE KEY IN THE MAIN GEARBOX DRIVE SHAFT	10
9. FATIGUE	10
9.1 Fatigue stress in the weld at the paddle hub	10
9.2 Fatigue stress between the weld at the main shaft and coupling flange	10
9.3 Fatigue stress in the gearbox main shaft	11

1. Introduction

The tuner (stirrer) is an essential part of a electromagnetic reverberation chamber as it moves (stirs) the standing waves within the chamber ensuring a statistically isotropic, randomly polarised and uniform energy field. The tuner consists of 4 paddles, each set at a different angle to the rotational axis, see photograph 1.

To achieve as low a frequency as possible from the DSTO chamber, a philosophy of using a single large tuner was employed, resulting in a tuner of 8 meters diameter. With the tuner assembly being large the consequences of a mechanical failure could be catastrophic, particularly if the structure were to fall onto an aircraft under test. It was therefore considered prudent to carry out a comprehensive structural analyses covering drive motor size, weld stresses, drive shaft torques, weld fatigue life, and the installation of a safety overload protection mechanism.

Analyses of a variety of over-load conditions are presented in this paper. As a result of the analyses, a number of minor modifications and the installation of a safety shear key are recommended.

2. Operating Parameters

2.1 Constructional requirements of the tuner paddles

The size of tuner paddles was principally determined by the size of the chamber. A tuner with four paddles each of 3.6m x 3.6m was chosen. Construction of the tuner had to be as light as practicable to keep inertia loads to a minimum, but at the same time had to be sufficiently rigid to keep the paddles from oscillating when the assembly is brought to a stop. The paddle material selected was commercial James Hardie 'Bondor' panels [1], commonly used for the manufacture of cool rooms. The panels are lightweight and have high rigidity, minimising the need for additional structural support. The Bondor Panels are comprised of a zinc coated steel sheet bonded to a styrene foam core. The panels have pre-formed edges, which allows them to be clipped together, and extruded aluminium capping to seal the edges of the panels.

2.2 Modes of operation

The tuner operates in two separate modes, variable stepping and continuous rotation.

2.2.1 Stepping mode

The tuner has a maximum of 400 steps per revolution. Step size can be increased in increments of one four hundredth of a revolution, until the tuner turns continuously. The maximum speed of the tuner is approximately 1rpm. The tuner should accelerate

to a maximum speed of one revolution per minute then decelerate at the same rate to stop at the step size selected. Velocity and acceleration diagrams are shown in figure A-1, Appendix A. The acceleration and deceleration rates must be high enough to keep the test time to a minimum, but low enough to avoid unacceptable oscillation when the tuner is returning to rest.

2.2.2 Continuous rotation

In the continuous rotation mode, the tuner accelerates at a pre-set rate to the maximum continuous rotational speed of 1rpm, then maintains this speed until requested to stop. The design of the drive motor controller is such that the magnitude of the acceleration and deceleration rates must be the same. The acceleration and deceleration values are pre-programmed into the controller software and cannot be adjusted by the operator.

3. Major parts of tuner

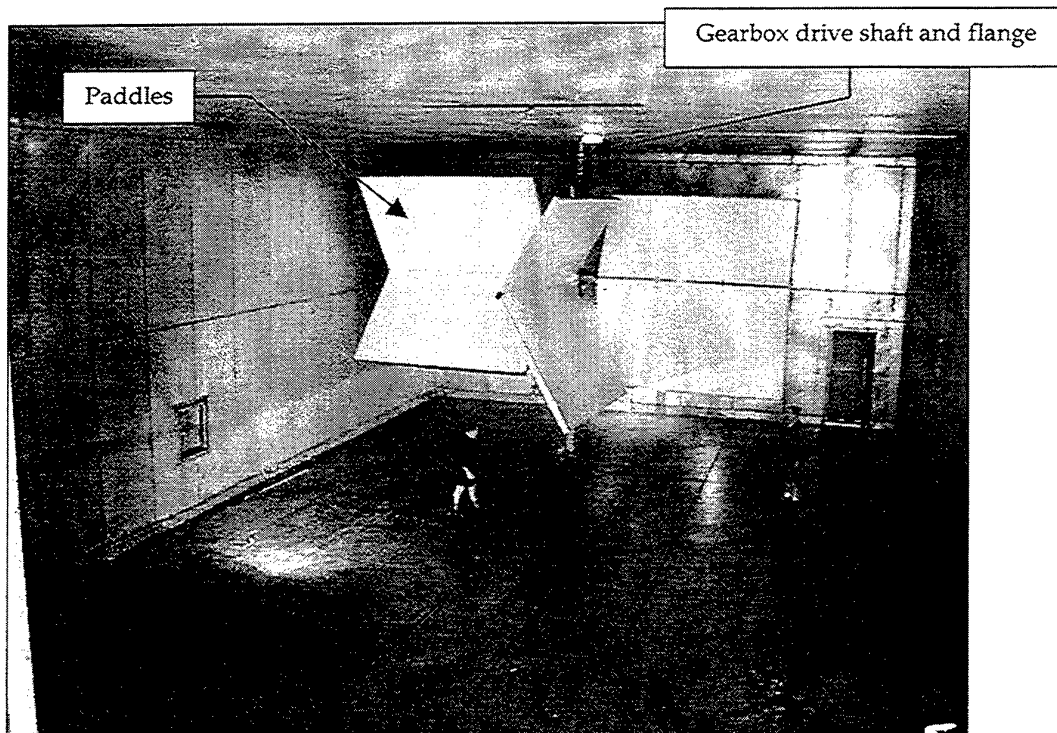

Photograph 1 Tuner assembly

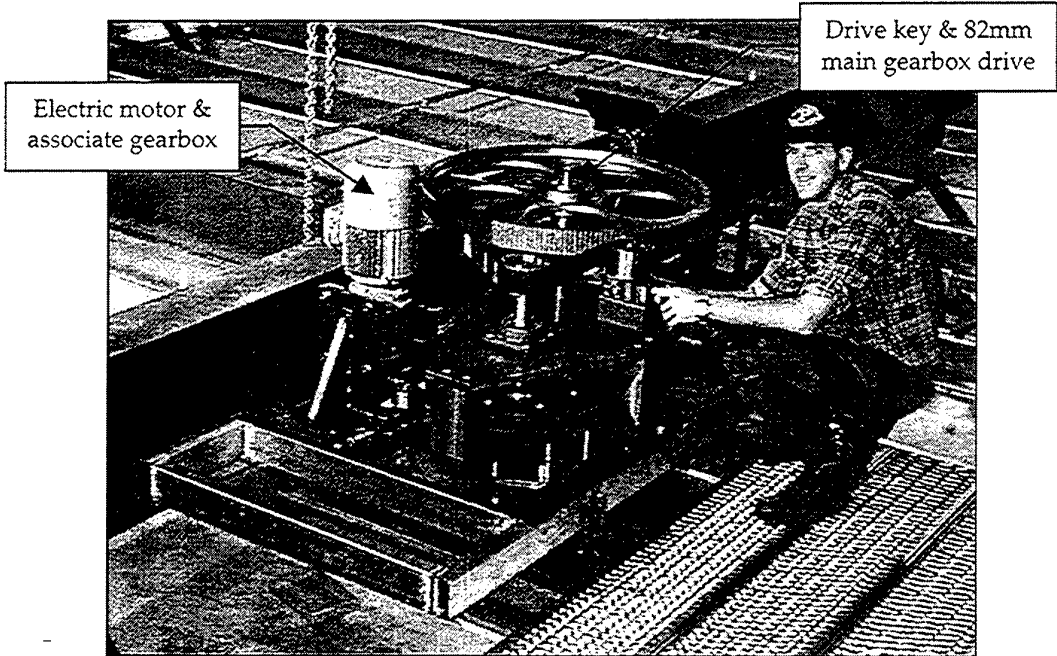

Photograph 2 Main gearbox assembly

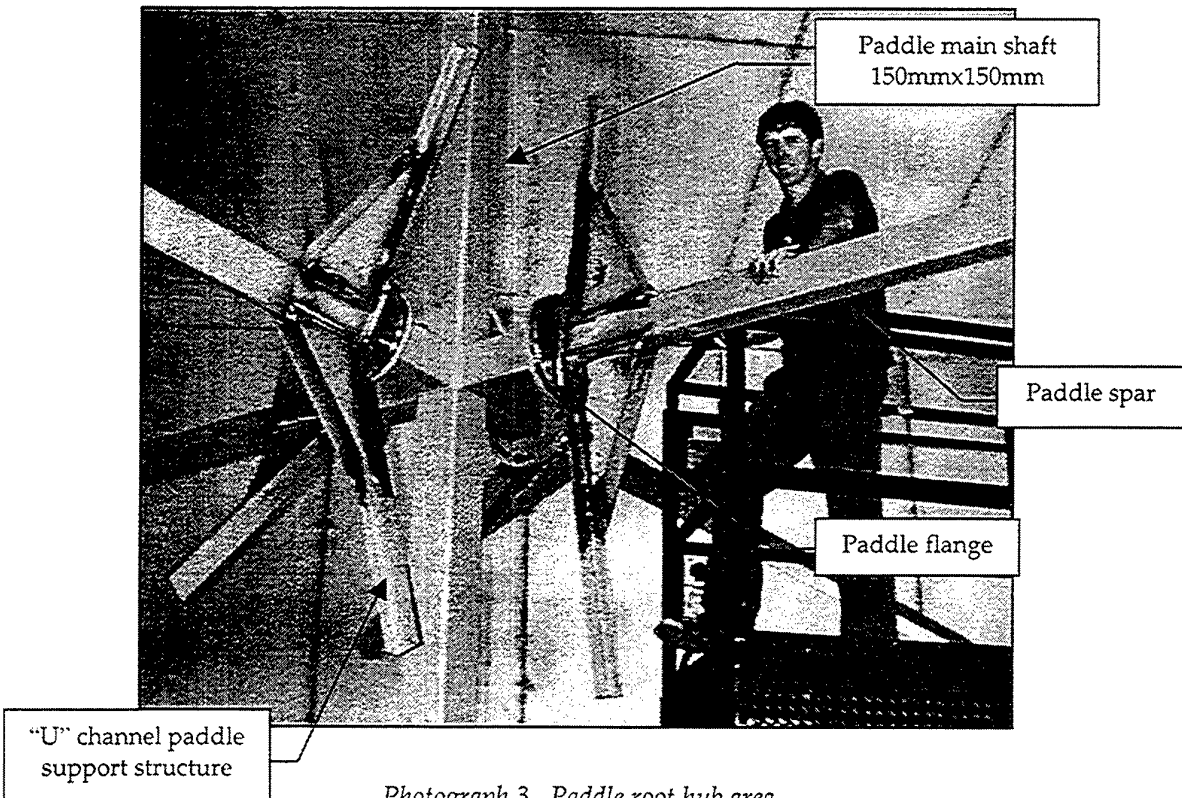

Photograph 3 Paddle root hub area

4. Drive motor and gearbox selection

4.1.1 Tuner inertia

The minimum tuner step is one 400th of a revolution, and the maximum rotational speed is one revolution per minute. The torque needed to accelerate the tuner was calculated at 7050.9Nm. The calculations can be found in Appendix A under the heading of "Gearbox drive motor selection".

4.1.2 Electric drive motor and gear box ratio selection

The electric drive motor was selected using the torque needed to accelerate the tuner.

The torque required to accelerate the tuner was calculated to be 7050.9Nm. The electric motor selected was a SEW Eurodrive DT90L4 [2], which has a rated maximum torque of 10.16Nm, and a stall torque of 2.5 times the maximum torque. Full motor speed is 1440rpm.

To obtain the desired tuner rotation rate of 1rpm, a drive reduction ratio of 1419:1 was selected using standard commercially available toothed belt gears.

There is an over design factor of 2.0 using a motor torque of 10.16Nm and a drive reduction ratio of 1419:1 to overcome inertia.

5. Operating conditions analysed

Stress analyses were carried out for the most highly stressed areas on the tuner under a variety of operating conditions. The drive motor's maximum torque, and stall torque, were used for all calculations. Weld and material strengths used in the calculations were taken from references [3] and [4].

5.1 Welds

Welds were analysed under the operation conditions listed at 4.1.1 below as follows;

- weld strength at the root of the paddle hub (see figure A-4 in Appendix A),
- weld strength at the joint between the spar mounting plate and paddle main spar (see figure A-9 in Appendix A), and
- the welds joining the 'U' channel paddle's structure to the main spar (see figure A-18 in Appendix A).

5.1.1 Modes of operation analysed

- Case 1: Normal running mode

- Case 2:Paddle jams while the motor is driving
- Case 3:Control card requests a sudden stop of the motor
- Case 4:Force on welds due to the weight of the paddle

5.2 Torque analysis

A torque analysis was undertaken for;

- the torque load generated due to the centre of gravity and inertia loads being off-centre to the paddle fixing flange in the welds joining the paddle to the main shaft (see figure 11 in Appendix A),
- the welds between gearbox drive shaft and the coupling flange, (see figure A-12 in Appendix A),
- main gearbox shaft, and
- main tuner shaft, (see figure A-14 in Appendix A).

5.3 Additional analyses

Additional analyses were undertaken for;

- stress on paddle spar cross section, (see 1 figure A-9 in Appendix),
- shear strength of the drive key in the main gearbox drive shaft, (see figure A-15 in Appendix A), and
- fatigue stress on welds around paddle hub.

6. Welds analysed

6.1 Weld stress at the root of the hub and shaft

Calculations relating to the weld stress at the root of the hub and shaft can be found in Appendix A under the heading "New parameters for calculations based on motor selected".

6.1.1 Case 1: Normal operation

Under normal running conditions, the operator selects the tuner step size from a menu provided by the control computer. Rotation speed, acceleration and deceleration rates of the tuner are pre-programmed into the control card, and are normally not altered by the operator.

During normal operation, the stress in the weld at the root of the paddle hub and shaft was found to be low. The stress was calculated to be 20.1MPa, giving a safety factor of 22.6.

6.1.2 Case 2: Paddle jams while the drive motor is in operation

This case occurs when something jams, for example one of the paddles, while the tuner is being driven. If a jam occurs, all the motor torque will be transmitted into one paddle. The stall torque of the motor was therefore used in these calculations.

The stress in the weld between the hub root and the main shaft was found to be quite high in this case. The stress was calculated to be 411.9MPa, giving a safety factor of 1.1.

Due to the low safety margin, it is recommended that four load distribution webs be installed to redistribute the load from one paddle to all four paddles. This will reduce the stress in the weld by a factor of 4, giving a new safety factor of 4.4. Details of the recommended webs are shown at figure A-6 in Appendix A, and illustrated by sketches SPA060, and SPA061 in Appendix B.

6.1.3 Case 3: Control card requests a sudden stop of the motor

Under the conditions when the tuner is rotating at maximum speed (1rpm), and a failure of the controller requests the motor to stop instantly, the motor applies a braking torque equal to the motor's stall torque to the gearbox. This may occur if a programming error, or other fault conditions, reduce the ramp up or ramp down time to zero.

The torque used in the calculations was the maximum stall torque, 2.5 times the maximum motor torque. Note that all four paddles will equally contribute to this torque, unlike case 2 above.

It was found that the weld was moderately stressed to 103MPa, giving a safety factor of 4.4. Even though this is considered safe, the consequences of a failure of the weld could be expensive and embarrassing, with a paddle falling onto equipment under test. For this reason, additional webs are recommended to be added in order to distribute the load into the main shaft. Adding webs with a minimum length of 150mm will raise the safety factor to 8.8. Refer to figure A-7 in Appendix A, and sketches SPA060 and SPA062 in Appendix B.

An additional benefit of adding these webs is the increased rigidity of the tuner. The increased rigidity helps to distribute the load into the main shaft, thus reducing the amplitude of flexure in the walls in the shaft. The reduced load will also reduce the number of oscillations of the paddles when the tuner stops.

6.1.4 Case 4: Stress in welds due to the weight of the paddle

The weld stress at the hub root due to the weight of the paddle was found to be low. The calculated stress of 56.7MPa gives a safety factor of 8. The webs recommended in

case 3 will further increase this safety margin. As the safety factor was already high at 8, further calculations were considered unnecessary.

6.2 Weld stress between the spar mounting plate and the paddle main spar

For calculation details refer to Appendix A.

6.2.1 Case 1: Normal running mode

Normal running conditions are the same as those described in 6.1.1 "Weld stress at the root of hub shaft".

Under normal operating conditions, the structure was found to be safe. The calculated weld stress was 56MPa, giving a safety factor of 8.1.

6.2.2 Case 2: Paddle jams while the motor is in operation

The paddle jam condition is the same as that described in 6.1.2 "Weld stress at the root of hub shaft".

Under a paddle jam condition, the weld was found to fail, with a weld stress of 686.5MPa, and safety factor of 0.66. The calculations did not take into consideration the recommended strengthening webs suggested in section 10.5.2. When these webs are taken into consideration, the weld stress is reduced to 286MPa, giving a safety factor of 1.6. As this condition is not a normal operating mode, this safety factor is considered adequate.

6.2.3 Case 3: Control card requests a sudden stop of the motor

The control card failure conditions are the same as those described in 6.1.3 "Weld stress at the root of hub shaft".

If a fault condition in the control card commands the motor to stop, the torque produced by the stalled motor will be distributed to all four paddles. This produces a weld stress of 173MPa and a safety factor of 2.6. The recommended strengthening webs suggested in section 4.1.3 were not taken into account. As the safety factor is adequate further calculations were considered unnecessary.

6.2.4 Case 4: Load on weld due to the weight of the paddle

The weld stress at the joint between the paddle spar and the main spar mounting plate was calculated to be 77.4MPa, giving a safety factor of 5.9. Therefore, no additional strengthening is required.

6.3 Weld stress on 'U' channel paddle structure

The welds in question are those that join the 'U' channel paddle support frame to the paddle main centre beam, as shown in figures A-17 and A-18 of Appendix A. The 'U' channel supports the Bondor panels, and transmits inertial loads between the panels and the main paddle support shaft.

During normal operation, the loads in this area were found to be low with a weld stress of 16.4MPa and safety factor of 27.7.

Calculations for Cases 2 and 3 were not undertaken, as it is difficult to determine how the loads would act on the 'U' channel paddle structure. However, with such a high safety factor, and the installation of a safety shear key as recommended in section 8, it is unlikely that the welds will ever be subjected to loads large enough to induce failure.

Case 4 does not apply, as the paddle weight is not supported by the 'U' shape paddle structure.

6.4 Stress on the paddle spar cross section

If the end of the paddle were to jam while the tuner is rotating, the interface between the paddle web and spar will transmit the full motor stall torque, (refer to figure A-10 in Appendix A). For this calculation, it was assumed that the centre of bending would be at the intersection of the strengthening web and the spar.

The analysis showed that the paddle spar would bend at the intersection point. The stress in the wall of the tube was calculated to be 769MPa, giving a safety factor of 0.59. However, as the paddles have already been assembled, they can not be easily strengthened. An alternative way of preventing this type of failure is therefore needed. A shear key is recommended to be installed into the gearbox drive train to limit the torque that can be transmitted into the tuner. Shear key calculations are described in section 8 of this document and detailed in Appendix A.

7. Torque calculations

7.1 Torque on the paddle flange welds, 100° paddle at 40°

The welds on the paddle flange are under a torque load due to the weight of the paddle and inertial loads being off-centre from the main support spar. Calculations were carried out for the worst case, the 100° paddle being at 40° to the vertical axis (refer to figure A-11 in Appendix A). The inertial and weight torques were combined, resulting in a weld stress of 18.8MPa, and a safety factor of 14.5.

7.2 Torsional loads between the gearbox main drive shaft and the drive flange

The strength of the weld joining the gearbox main drive shaft to the paddle-coupling flange was found to be adequate under normal operating conditions, (refer to figure A-12 in Appendix A). Under normal operating conditions, the stress in the welds was calculated to be 59.6MPa, giving a safety factor of 4.9.

For case 2, as described in section 6.1.2, when the paddle jams while the motor is in operation, the weld stress increases to 304.8MPa, giving an unsatisfactory safety factor of 0.9. These calculations indicate that the weld will fail in a paddle-jammed condition. If the paddle jams, the full motor stall torque is applied to the drive shaft. Calculations indicate that the paddle spar will bend before enough torque is generated to shear the welds on gearbox drive shaft. The safety factor of paddle spar is 0.59 compared to a safety factor of 0.9 for the drive shaft weld.

Because the shaft goes through the drive flange, failure of the weld is unlikely to cause the tuner to fall. However, the result of the tuner falling could be catastrophic so the installation of a retaining ring is recommended in order to prevent the tuner from falling. The overload safety shear key recommended in section 8 is additional protection from this type of failure.

7.3 Torsional load on the 82mm diameter main gearbox shaft

Under normal operating conditions, the stress in the gearbox drive shaft was calculated to be 65MPa, resulting in a safety factor of 3.3. For case 2, as described in 6.1.2, where the tuner jams while the motor is in operation, the torsional stress in the outer-most fibre of the main gearbox shaft is 215MPa, giving an unsatisfactory safety factor of 0.65. In sections 6.4 and 8, a safety shear key is recommended (see section A-9 for calculations). The safety key size is such that it will shear before sufficient torque can be generated to cause damage to the paddle and gearbox assembly.

7.4 Torsional load on the tuner 150mm by 150mm main shaft

Under normal operating conditions, the torque generated in the main shaft results in a safety factor of 7.2. For the stalled motor case as described in 6.1.2, the safety factor is a safe 1.4.

8. Shear strength of the drive key in the main gearbox drive shaft

The present drive key, which is 70mm long, in the main gearbox drive shaft is capable of driving 1.5 times the load applied during normal operation. It is recommended that this key be reduced in length so as to transmit a drive torque of 1.1 times the normal operating load. The calculated length of the safety key is 52.5mm, (see text and figure A-15 in Appendix A for calculation details). Using the drive motor stall torque value gives a safety factor of 0.22, thus protecting the assembly.

9. Fatigue

Fatigue life was calculated using the following assumptions;

- there are 400 steps per revolution in stepping mode, based on twice the number of steps required in [8].
- the structure goes through 4 oscillations before coming to rest when it stops,
- the average usage rate is one revolution per day (400 steps/day),
- the average usage rate is 365 days per year, and
- the life of the chamber is 6 years.

It was thought prudent that fatigue life be considered, as the structure would go through a large number of stress cycles during its life. Using the above parameters, it was calculated that the structure will go through 3,504,000 cycles during its life. Fatigue stress is generally only taken into consideration for more than one million operation cycles.

9.1 Fatigue stress in the weld at the paddle hub

The fatigue stress at the paddle hub was calculated to be 20.1MPa. The allowable lower limit before fatigue life is taken into consideration is 209.6MPa (stress value for a long life). The actual stress in the weld is only 10% of the allowed value, so fatigue in the weld at the paddle hub will not be a problem (for calculation details refer to Appendix A).

9.2 Fatigue stress between the weld at the main shaft and coupling flange

The fatigue stress at the main shaft and coupling flange was calculated to be 59.6MPa. The allowable lower limit before fatigue life is taken into consideration is 209.6MPa (stress value for a long life). The actual stress in the welds is only 28% of the allowable value. So fatigue in this area is not considered to be a problem (for calculation details refer to Appendix A).

9.3 Fatigue stress in the gearbox main shaft

The fatigue stress in the gearbox main shaft was calculated to be 65MPa. The allowable lower limit before fatigue life is taken into consideration is 209.6MPa (stress value for long life). The calculated stress in the shaft is only 31% of the allowable value and is therefore considered not to be a problem (for calculation details refer to Appendix A).

9.3.1 Additional information

The material used in the main gearbox shaft is not known, so the endurance strength is also not known. A hardness test of the shaft was carried out [5]. A material of similar hardness characteristics was used to provide the parameters for the calculations. A conservative material was chosen from a materials listed in [6].

Under normal operating conditions, the actual stresses calculated were low compared to the allowable fatigue stress for long life, being 31%, 28% and 10% respectively for the 3 cases. As these figures are all low, inaccuracies due to the choice of material are unlikely to effect the outcome.

Even though fatigue failure is not considered a possibility using the parameters specified, an analysis of a failure has still been undertaken. The most highly stressed section is the gearbox main shaft, which is stressed at 31% of the allowable lower limit. Failures are most likely to occur:

- at the end of the keyway on top of the shaft where the main drive gear is attached. If the shaft breaks here, the tuner is still held by the two main shaft bearings so toppling of the tuner cannot occur;
- in the heat effected area next to the weld on the flange end of the drive shaft. If failure occurs here, toppling of the tuner will be prevented by the installation of the safety collar recommended in section 10.5.3 (see recommendations, and figure A-13 in Appendix A, and Drawing SGBX050 in Appendix B), and
- at the weld joining the flange to the main shaft. If failure occurs here, the recommend safety collar will prevent toppling of the tuner.

10. Summary

Case Assessed	Description of case	Safety factor	Recom-mendations
Motor size	Motor selected against torque required to move tuner	2.0	nil
Strength of welds	at root of hub & shaft		
	Case 1: normal running mode	22.6	nil
	Case 2: Paddle jams while the motor is driving	1.1	Add Webs
	Case 2: with recommended webs added	4.4	
	Case 3: Control card malfunction	4.4	Add Webs
	Case 3: with recommended webs added	8.8	
	Case 4: Force on welds due to weight of the paddles	8	nil
	between spar mounting plate & paddle main spar		
	Case 1: normal running mode	8.1	nil
	Case 2: Paddle jams while the motor is driving	0.66	Add Webs
	Case 2: with recommended webs added	1.6	
	Case 3: Control card malfunction	2.6	
	Case 4: Force on welds due to weight of the paddles	5.9	
	Case 5: Stress on spar cross section, tuner jams	0.59	Not practical to modify. Recommend drive key shortened.
	Torque calculations	due to weight of panel, & inertial load	14.5
on weld between main shaft & coupling flange (stall torque)		0.9	Retaining ring added
on weld between main shaft & coupling flange (normal)		4.6	
on main gearbox shaft (motor stall case)		0.65	Retaining ring added
on main gearbox shaft (normal operation case)		3.3	
on main tuner drive shaft (motor stall case)		1.4	
on main tuner drive shaft (normal operation)		7.2	
Key in main gearbox shaft	When operating under normal operating conditions	1.5	Key length shortened
	With recommended new length of key (52.5mm).	1.1	
	When electric motor is in a stalled condition (old length).	0.31	
	When operating under motor stall conditions (key length 52.5mm)	0.22	
Stress on U channel	stress on "U" channel welds	27.7	
Fatigue calculations	Total number of cycles during the structure lifetime (3,504,000 cycles)		Fatigue life to be considered
	Fatigue stress (paddle hub)	10%	fatigue not a problem
	Fatigue stress (weld, main gearbox shaft & flange coupling)	28%	fatigue not a problem
	Fatigue stress (Main gearbox shaft)	31%	fatigue not a problem

Table 1 Summary table of calculations

10.1 Stress during normal operation

The tuner is structurally sound when operating under normal conditions. The minimum safety factor calculated for these conditions is 5.9.

10.2 Torsion

10.2.1 Torsional load at the paddle hub

The torsional loading under normal operating conditions at the paddle hub is well within reasonable safety limits, with a calculated safety factor of 14.6.

10.2.2 Torsional load on the weld between the main gearbox shaft and the top flange

Under normal operating conditions, the welds between the main gearbox shaft and the top flange are more highly stressed than in other areas, but are still within acceptable limits, with a safety factor of 4.6.

Under the abnormal conditions where the tuner may jam, the safety factor is considerably reduced. In the worst case, the welds will just fail (safety factor of 0.9). Recommendations are made for the installation of a safety shear key to limit damage.

10.3 Fatigue

Even though the tuner will undergo a large number of cycles during its life, it was found that the stress in the welds during normal operating conditions is so low that fatigue failure will not occur. Using the stresses encountered under normal operating conditions, the calculated fatigue stress is 10%, 28%, and 56%, of the allowable limit, for the 3 cases respectively.

10.4 Failure modes

Two abnormal conditions were considered in the calculation;

- Case 2:paddle jams while the motor is running, and
- Case 3:control card requests a sudden stop of the motor.

10.4.1 Case 2: paddle jams while the motor is running

- The strength of the hub assembly was found to be marginal in this mode, with a modest safety factor of 1.1. The addition of load distribution webs is recommended. This modification increases the safety factor to 4.4, (see "Recommendations" section 10.5.1, and Appendix A "Recommendation" figure A-6).

- The strength of the joint between the spar and mounting plate was also found to be marginal in this mode, with a safety factor of 1.6.
- Stress on the paddle main structural spar is such that the spar will bend if one paddle is jammed during operation. As the paddles have already been made, a modification is difficult. The chance of the paddle being subjected to this kind of load is low. An overload shear key is recommended to minimise the possibility of paddle bending, (refer to section 6.4).

10.4.2 Case 3: Control card requests a sudden stop of the motor

- It was found that the welds at the hub assembly will not fail under this type of load condition (safety factor is 4.4).
- The strength of the joint between the spar and mounting plate is satisfactory, with a safety factor of 2.4.

10.5 Recommendations

Several recommendations are made.

10.5.1 Load distribution webs

Load distribution webs are recommended to distribute the load from one weld into all vertical hub welds (refer to section 6.1.2 in this document, Figure A-6 in Appendix A, and sketches SPA060 and SPA061 in Appendix B).

10.5.2 Strengthening webs

Two vertical webs are recommended to give additional strength to the vertical welds at the root of each paddle hub (refer to section 6.1.3, Figure A-7 in Appendix A, and sketch SPA062 in Appendix B). The webs should be a minimum of 150mm long.

10.5.3 Safety Collar

A safety retaining-collar is recommended in sections 7.2 and 9.3.1. The collar is designed to retain the tuner if the welds or gearbox drive shaft fail (refer to Figure A-13 in Appendix A, and sketch SGBX050 in Appendix B for details).

10.5.4 Isolation switch

The case where the paddle jams while the motor is being driven is most likely way an accident can occur. This type of accident will result in the paddle being damaged. To prevent this, an isolation switch is recommended to be installed in the motor controller. This will allow the tuner to be isolated when there is equipment such as scaffolding, scissor-lift, or fork-lifts around it, thus preventing the paddle from jamming if it is accidentally turned on.

The installation of an isolation switch in the chamber will:

- prevent the tuner from being accidentally operated from the remote control panel while work is being carried out in the chamber, and
- force the operator to enter the chamber to turn the isolation switch back on, which will make the operator aware of anybody working on the tuner as well as any object in the chamber that could interfere with the paddle.

10.5.5 Action on recommendations

As of the date of writing, recommendations 10.5.1 to 10.5.3 have been actioned and completed. The isolation switch (recommendation 10.5 4) is to be installed as soon as convenient, consistent with the current work schedule.

11. References

- 1 James Hardie Bondor Building Systems BS-1018-SB (Cold storage)
- 2 SEW-EURODRIVE Pty. Ltd. Faximile Reference number L/3288
- 3 MIG Auto Craft, Weld filler rod "LW1"
- 4 Palmer Tube Mills, Product Data Sheet 6.1.1 and 6.1.2
- 5 DSTO Scientific and Engineering Services, Material Science Report Number 634
- 6 Virgil Moring Faires, "Design of Machine Elements", fourth edition
- 7 Watkins, Jensen, Chenoweth, "Applied Engineering Mechanics", Second edition
- 8 M L Crawford and G H Koepke, "Design, evaluation, and use of a reverberation chamber performance electromagnetic susceptibility / vulnerability measurements." Nat. Bur. Stands. (U.S.) Tech. Note 1092, April 1986.

DSTO-TN-0272

Appendix A: Calculations

This appendix contains the original design calculations but has revised safety margin calculations added to include anticipated failure modes.

At the time of design, no tuner design parameters existed for this size electromagnetic reverberation chamber. With the experts undecided as to the best shape and size of the tuner, assumptions were made about the tuner requirements and were therefore subject to design changes. Calculations are based on the original assumptions.

A.1. Moment of Inertia of Tuner

A.1.1 Weight of each paddle

- Bondor sheet material weighs 11.5kg/m²
Size 3.6m x 3.6m = 12.96m² (see sketch no. SPA 003 PL)
weight of Bondor sheet = 12.96 x 11.5 = 149kg
- Centre tube weighs 14.2kg/m
Length of centre support tube = 3.6m
weight of tube = 14.2 x 3.6 = 51.12kg/paddle
- Estimated additional weight of aluminium capping, channel, webs, shaft & flange, is 30kg

Total weight of a paddle = 149 + 51 + 30 = 230kg

A.2. Acceleration profile

A.2.1 Required modes of operation

- The tuner is required to step in increments of 0.9° (400 steps per revolution).
- The tuner is to operate in a continuous rotation mode. Start and stop acceleration profiles are to be same, irrespective of the step size.
- Maximum operating speed is 1rpm.

The curves shown in figure A-1 are idealistic. The motor controller keeps motor current constant during acceleration, this ensures near constant torque and hence acceleration as the tuner speeds up or slow down. A square acceleration profile is a reasonable approximation.

A.2.2 Moment of inertia of the tuner during stepping

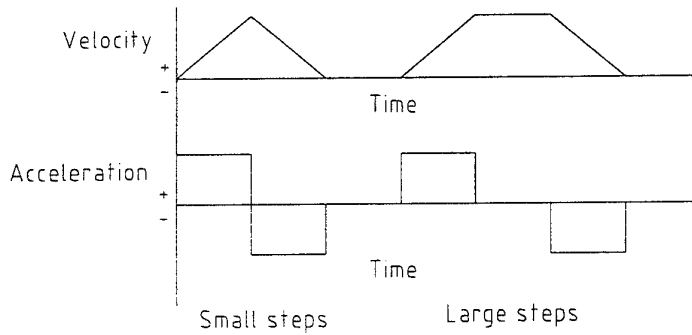

Figure A-1 Velocity & Acceleration diagram.

Time taken for one step = $60 \div 400 = 0.15\text{s}$

Acceleration and deceleration time = $0.15 \div 2 = 0.075\text{s}$

The tuner turns at 2π radians per minute. (1 rev = 2π radians)

The angular rotation during the acceleration phase for one step = $2\pi \div (400 \times 2)$
 $= 0.00785\text{rad}$

The rotation occurs over 0.075s

Average angular velocity = angular rotation \div time taken

Therefore average angular velocity = $0.00785 \div 0.075 = 0.1047\text{rad/s}$

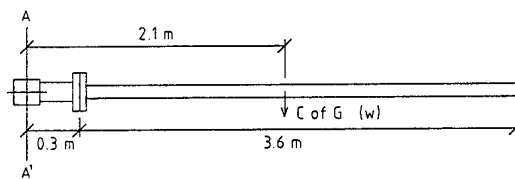

Figure A-2 Paddle moment arm on main shaft

The moment of inertia formula is taken from reference [7], page 325.

$$I_A = (1/12 \times Ml^2) + (Md^2)$$

Where

I_A = moment of inertia about axis A A¹.

M = Mass of panel = 230kg

l = size of panel = 3.6m

d = radius of gyration = $(3.6 \div 2) + 0.3 = 2.1\text{m}$

$$I_A = 230 \times 3.6^2 \div 12 + 230 \times 2.1^2$$

$$I_A = 248.4 + 1014.3 = 1262.7\text{kgm}^2$$

Inertia for one paddle = 1262.7kgm²

Inertia for four paddles = 5050.8kgm²

Angular acceleration $\alpha = (\omega - \omega_0) \div t$

where

final angular velocity $\omega = 0.1047\text{rad/s}$

initial angular velocity $\omega_0 = 0.0\text{rad/s}$

time t = 0.075s

$$\alpha = 0.1047 \div 0.075$$

$$= 1.396\text{rad/s}^2$$

A.2.3 Torque required to accelerate the tuner

The torque formula is taken from reference [7], page 323.

torque = moment of inertia \times angular acceleration = $I\alpha$

$I = 5050.8\text{kgm}^2$ (as calculated Appendix A "Moment of inertia of the tuner during stepping")

$\alpha = 1.396\text{rad/s}^2$ (as calculated above)

$$\therefore \text{Torque} = 5050.8 \times 1.396$$

$$= 7050.9\text{Nm} \quad (4 \text{ paddles, normal operation})$$

$$= 1762.7\text{Nm} \quad (1 \text{ paddle, normal operation})$$

A.3. Gearbox drive motor selection

Torque required to drive 4 paddles is 7050.9Nm.

Gear box information

Reduction ratios

Gearbox reduction ratio= 30.16 : 1

First toothed belt reduction ratio= 6.86 : 1

Second toothed belt reduction ratio= 6.86 : 1

Total reduction between electric motor and tuner shaft= 1419.3 : 1

Max torque required at gearbox output shaft = 7050.9Nm

Torque required at motor shaft = $7050.9 \div 1419$
= 4.969Nm

Motor selected

SEW Eurodrive motor DT90L4

From manufactures data sheet (see reference [2])

Motor torque= 10.16Nm

Stall torque of electric motor= 2.5 x motor torque
= 25.4Nm

Torque of selected motor (new design torques)

Max torque at gearbox output shaft = total reduction ratio x motor torque
= 1419×10.16
= 14417Nm

Stall torque on gearbox output shaft = 14417×2.5
= 36042Nm

Motor safety factor

Torque required to accelerated tuner is 7050.9Nm (as calculated Appendix A "Torque required to accelerate tuner")

Safety factor = Torque of motor selected \div torque required = $14417 \div 7050.9$
Safety factor = 2.0

A.4. New parameters for calculations based on motor selected

The design torques used in the following calculations are the maximum torque of the electric motor and the stall torque of the motor.

Modes of operation analysed:

- Case 1: normal running mode,
- Case 2: paddle jams while the motor is driving,
- Case 3: control card requests a sudden stop of the motor, and
- Case 4: force on welds due to the weight of the paddle.

A.5. General weld strength calculations

Cross section of weld

The weld size as requested on drawing (see sketch SPA002) is 8mm.

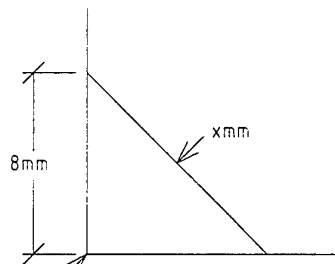

Figure A- 3 Weld cross section

x = smallest cross section of the weld, root thickness

$$x = \sin 45^\circ \times 8$$

Root thickness of weld = 5.6mm

length of weld = 125mm (see sketch SPA 023)

Cross section of each weld at root of paddle shaft and paddle hub = 5.6×125
= 700mm^2

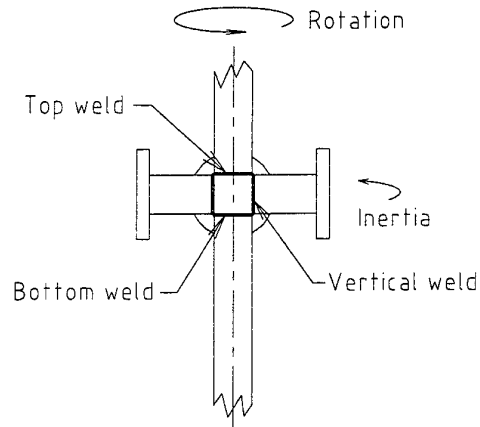

Figure A-4 Main shaft, paddle hub block welds (side view)

Only the vertical welds are considered in the inertial load calculations. The strength of top and bottom welds are not considered.

length of weld = 125mm (see sketch SPA 023)

Note: horizontal & vertical welds have the same length, i.e. 125mm

Cross sectional area of each weld at root of paddle shaft and paddle hub = 5.6×125

area of weld = 700mm^2

Weld filler rod details

The weld filler rod (see reference [3])

455MPa Yield strength

560MPa Ultimate Tensile strength

A.6. Weld strength at root of hub and shaft

A.6.1 Case 1: Normal running mode

During normal operation, the drive motor speed, paddle acceleration and deceleration rates are pre-programmed into the control card, and cannot be adjusted by the operator. Rotational step size is the only parameter that can be altered.

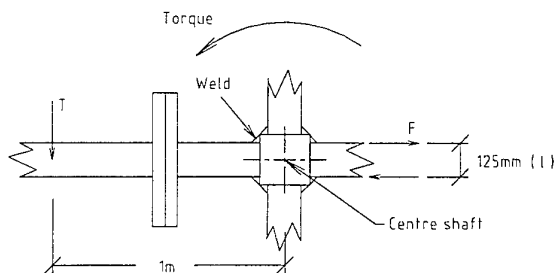

Figure A-5 Inertia load on hub block welds (plan view)

Data

$I = 5050.8 \text{kgm}^2$ (as calculated on page 19; normal running mode, 4 paddles)

$\alpha = 1.396 \text{rad/s}^2$ (calculated on page 19)

$l = \text{distance between welds} = 0.125 \text{m}$

Area of weld = 700mm^2 (from page 21)

yield strength of welding rod = 455MPa

Torque = 7050.9Nm (as calculated Appendix A "Torque required to accelerate tuner")

= 1762.7Nm (1 paddle, normal operation)

Torque = Force couple on weld

Force on welds $F = \text{torque} \div \text{distance between welds } (l)$

$$F = 1762.7 \div 0.125$$

$$F = 14102 \text{N}$$

Stress on weld

Weld stress = load \div area of weld

$$= 14102 \div 700$$

$$= 20.1 \text{MPa}$$

Safety factor

Safety factor = yield stress \div actual stress

$$= 455 \div 20.1$$

$$= 22.6$$

A.6.2 Case 2: Paddle jams while the motor is driving

This case is where something jams one of the paddles while the tuner is being driven.

All the torque is transmitted into one paddle.

The stall torque of the motor is used for this case.

Data

Stall torque on gear box output shaft 'T' = 36042Nm (as calculated Appendix A

"Gearbox drive motor selection")

area of weld = 700mm² (0.0007m²)

distance between welds l = 0.125m

yield strength of welding rod = 455MPa

F = load on the weld

$$\begin{aligned}
 F &= T \div l \\
 &= 36042 \div 0.125 \\
 &= 288336\text{N}
 \end{aligned}$$

Stress in weld

$$\begin{aligned}
 \text{weld stress} &= \text{load} \div \text{area} \\
 &= 288336 \div 700 \\
 &= 411.9\text{MPa}
 \end{aligned}$$

Safety factor

$$\begin{aligned}
 \text{Safety factor} &= \text{yield stress} \div \text{actual stress} \\
 &= 455 \div 411.9 \\
 &= 1.1
 \end{aligned}$$

Recommendation

Since the safety factor is low, a web is recommended between each paddle support in order to transfer the load into all 4 paddle support welds instead of being absorbed by one. This will increase the safety factor to 4.4 (see Figure A-6 below).

For details refer to Appendix B, sketches SPA060 and SPA061, which show the recommended modifications.

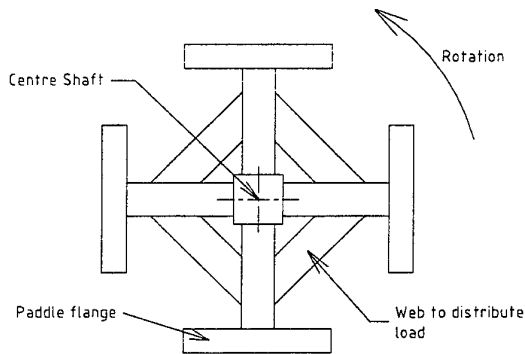

Figure A-6 Proposed load distribution webs (paddle hub, plan view)

A.6.3 Case 3: Control card requests a sudden stop of the motor

Case 3 is where the tuner is rotating at max rpm (1rpm), and the controller demands the motor to instantly stop with electric power still connected to the motor. The torque used in these calculations is the max stall torque of the motor, with the energy being absorbed by all 4 paddles.

Data

Stall torque on gear box output shaft = 36042Nm (as calculated Appendix A
"Gearbox drive motor selection")

Torque on 4 paddles = $36042 \div 4 = 9010\text{Nm}$

Therefore torque induced into each paddle = 9010Nm

distance between welds 'l' = 125mm

Area of weld = 700mm²

yield strength of welding rod = 455MPa

Load couple on weld = torque

$$\begin{aligned} F &= \text{torque} \div l \\ &= 9010 \div 0.125 \\ &= 72080\text{N} \end{aligned}$$

Stress in weld

$$\begin{aligned} \text{weld stress} &= \text{load} \div \text{area} \\ &= 72080 \div 700 \\ &= 103\text{MPa} \end{aligned}$$

Safety factor

$$\begin{aligned} \text{Safety factor} &= \text{yield stress} \div \text{actual stress} \\ &= 455 \div 103 \\ &= 4.4 \end{aligned}$$

Recommendation

Even though the weld strength is adequate, the consequence of failure of this weld is that a tuner may fall onto the equipment under test. It is therefore recommended that two 8mm thick webs with a minimum height of 150mm be welded onto each outer edge of the hub shaft. This will double the length of the weld, reduce the stress by 50%, and double the safety factor to 8.8 (see figure A-7 below).

Adding these webs will increase the rigidity of the tuner structure by reducing flexing in the walls of the main shaft. This will reduce the number of oscillations of the paddles then the tuner is stopped, and increase fatigue life.

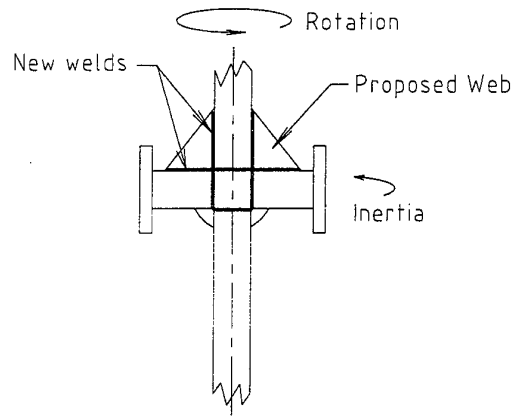

Figure A-7 Proposed strengthening webs (paddle hub, side view)

A.6.4 Case 4: Force on weld due to the weight of the Paddle

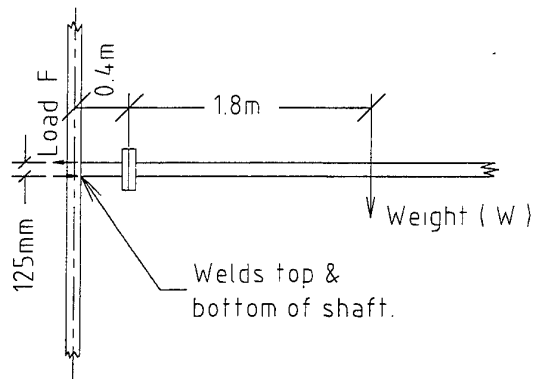

Figure A-8 Loads on hub welds due to paddle weight

Data

Mass of Paddle = 230kg

Weight of Paddle 'W' (230 x 9.81) = 2256.3N

Load on weld 'F' = F

Distance paddle C of G is from centre line of main shaft 'd' = 1.8 + 0.4 = 2.2m

Area of weld(from Appendix A "General weld strength calculations) = 700mm²

Distance between welds 'l' = 125mm

Length of vertical weld = 125mm

yield strength of welding rod = 455MPa

yield strength of steel main shaft = 450MPa

Load taken by horizontal weld

$$F \times l = W \times d$$

$$F = W \times d \div l$$

$$= 2256.3 \times 2.2 \div 0.125$$

$$= 39711\text{N}$$

Stress in weld

weld stress= load \div area

$$= 39711 \div 700$$

$$= 56.7\text{MPa}$$

Safety factor

Safety factor= yield stress \div actual stress

$$= 455 \div 56.7$$

$$= 8$$

A.7. Weld strength at joint between spar mounting plate and paddle main spar

- Case 1: Normal running mode
- Case 2: Tuner jams while the motor is driving
- Case 3: Control card requests a sudden stop of the motor
- Case 4: Load on weld due to the weight of the paddle
- Case 5: Stress on spar cross section thickness

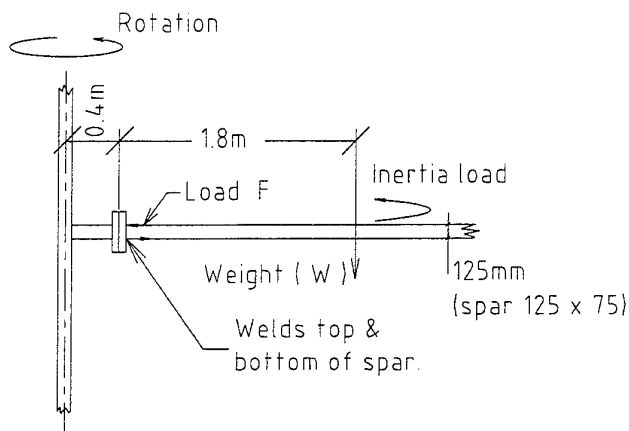

Figure A-9 Stress in welds joining spar mounting plate to paddle main spar

Data

- mass of Paddle= 230kg
- weight of Paddle 'W' (230 x 9.81)= 2256.3N
- load on weld 'F' = F
- distance of weld to centre of gravity of paddle 'd' = 1.8m
- distance between weld, horizontal 'H' = 0.125m
- distance between weld, vertical 'V' = 0.075m
- length of spar top/bottom weld= 0.075m
- length of spar side welds= 0.125m
- root thickness of 8mm weld= 5.6mm
- yield strength of welding rod= 455MPa
- yield strength of steel main shaft = 450MPa
- torque on each paddle (from Appendix A "Torque required to accelerate tuner")
= 1762.7Nm (one paddle)
- stall torque on gear box output shaft (from Appendix A "Gearbox drive motor selection")= 36042Nm

A.7.1 Case 1: Normal running mode

Force on side welds due to inertia load.

Torque = Force couple on weld

$$\begin{aligned} F &= T \div V \\ &= 1762.7 \div 0.075 \\ &= 23503\text{N} \end{aligned}$$

Weld area

$$\begin{aligned} &= \text{cross section of weld} \times \text{length of weld} \\ &= 5.6 \times 75 \\ &= 420\text{mm}^2 \end{aligned}$$

Stress on weld

$$\begin{aligned} \text{load} &= 23503\text{N} \\ \text{area} &= 420\text{mm}^2 \\ \text{weld stress} &= \text{load} \div \text{area of weld} \\ &= 23503 \div 420 \\ &= 56\text{MPa} \end{aligned}$$

Safety factor

$$\begin{aligned} \text{safety factor} &= \text{material yield strength} \div \text{weld stress} \\ &= 455 \div 56 \\ &= 8.1 \end{aligned}$$

A.7.2 Case 2: Tuner jams while the motor is driving

Data used is from Appendix A "Case 4: Force on weld due to the weight of the paddle".

Force on side welds due to motor being stalled.

$$\begin{aligned} F &= \text{Stall torque of motor} \div \text{distance between vertical welds} \\ &= 36042 \div 0.075 \\ &= 480560\text{N} \end{aligned}$$

Weld area

$$\begin{aligned} &= \text{Cross section of weld} \times \text{length of vertical weld} \\ &= 5.6 \times 125 \\ &= 700\text{mm}^2 \end{aligned}$$

Stress on weld

$$\begin{aligned} \text{load} &= 480560\text{N} \\ \text{area} &= 700\text{mm}^2 \end{aligned}$$

$$\begin{aligned}\text{weld stress} &= \text{load} \div \text{area of weld} \\ &= 480560 \div 700 \\ &= 686.5\text{MPa}\end{aligned}$$

Safety factor

$$\begin{aligned}\text{Safety factor} &= \text{material yield strength} \div \text{weld stress} \\ &= 455 \div 686.5 \\ \text{Safety factor} &= 0.66\end{aligned}$$

For the safety factor above, the added strength due to the strengthening webs has not been taken into account. The weld will fail for the condition where the tuner jams while motor running.

The previous case is recalculated taking into account the added strength due to strengthening webs.

A.7.3 Case 2 A: Tuner jams while the motor is driving (Webs added)

Use data from Appendix A, "Weld strength at joint between spar mounting plate and paddle main spar.

minimum length of web recommended in case 3= 150mm
length of vertical weld on spar= 150mm
length of vertical weld on spar + web= 300mm

Weld area

$$\begin{aligned}\text{weld area} &= \text{root section of weld} \times \text{length vertical weld on spar mounting plate} \\ &= 5.6 \times 300 \\ &= 1680\text{mm}^2\end{aligned}$$

Stress on weld

$$\begin{aligned}\text{load} &= 480560\text{N (from Appendix A, "Case 2: Paddle jams while the motor is driving")} \\ \text{area} &= 1680\text{mm}^2 \\ \text{weld stress} &= \text{load} \div \text{area of weld} \\ &= 480560 \div 1680 \\ &= 286\text{MPa}\end{aligned}$$

Safety factor

$$\begin{aligned}\text{safety factor} &= \text{material yield strength} \div \text{weld stress} \\ &= 455 \div 286 \\ &= 1.6\end{aligned}$$

Considering the recommended strengthening webs of minimum length (150mm), the weld is just strong enough (safety factor of 1.6).

Additional protection will be provided by the installation of the shear safety key, as recommended in Appendix A "Recommended length of Key".

A.7.4 Case 3: Control card requests a sudden stop of the motor

(Strengthening webs are not considered in the calculations.)

Data

Data used from Appendix A "Case 4: Force on weld due to the weight of the paddle".

Stall torque on gearbox output shaft is distributed between the 4 paddles = 3642Nm (from Appendix A "Gearbox drive motor selection").

Therefore torque induced into each paddle = $3642 \div 4 = 9010\text{Nm}$

distance between vertical welds 'V' = 75mm (0.075m)

Load couple on weld = torque on each paddle

force on weld = torque \div V

= $9010 \div 0.075$

= 120133N

Stress on weld

load = 120133N

area = cross section of weld \times vertical length of weld = $5.6 \times 125 = 700\text{mm}^2$

weld stress = load \div area of weld

= $120133 \div 700$

= 173MPa

Safety factor

safety factor = material yield strength \div weld stress

= $455 \div 173$

= 2.6

A.7.5 Case 4: Load on weld due to the weight of the paddle

Data

Data used from Appendix A "Case 4: Force on weld due to the weight of the paddle".

load on weld 'F' \times , distance between couple force 'H' = $W \times d$

$F = W \times d \div H$

$F = 2256.3 \times 1.8 \div 0.125 = 32490\text{N}$

Cross sectional area of weld for above (weld at the top of the spar) = $5.6 \times 75 = 420\text{mm}^2$

Stress on weld

$$\begin{aligned} \text{stress on weld} &= \text{load} \div \text{area} \\ &= 32490 \div 420 \\ &= 77.4\text{MPa} \end{aligned}$$

Safety factor

$$\begin{aligned} \text{safety factor} &= \text{yield strength} \div \text{stress} \\ &= 455 \div 77.4 \\ &= 5.9 \end{aligned}$$

A.7.6 Case 5: Stress on spar cross section

Data

Data used from Appendix A "Case 4: Force on weld due to the weight of the paddle".

Consider the spar bending at the web-spar interface if the end of the paddle jams during rotation. All of the motor stall torque is transmitted into one paddle. If the spar bends, the centre of rotation is now at the web-spar interface.

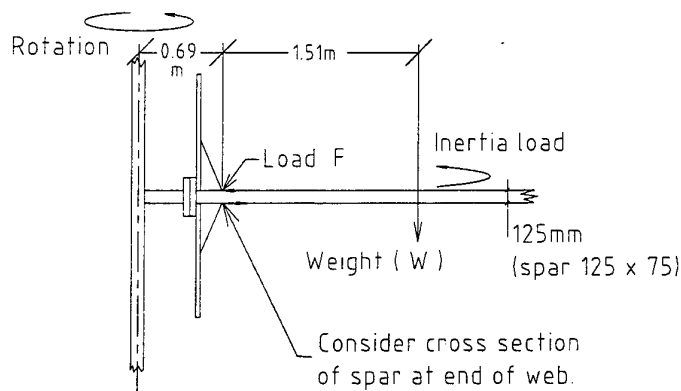

Figure A-10 Stress in spar at web-spar intersection

From figure A-10, distance from web spar interface to centre of rotation = 0.69m

Load taken by spar vertical wall

Load 'F' in vertical wall of the spar due to paddle jamming and the motor stalling.

stall torque = $V \times F$ (in vertical wall)

$$36042 = 0.075 \times F$$

$$F = 36042 \div 0.075$$

$$= 480560\text{N}$$

area of vertical wall (5mm wall thickness)

$$125 \times 5$$

$$625\text{mm}^2$$

Stress on wall

stress on wall = load \div area

$$= 480560 \div 625$$

$$= 768.9\text{MPa}$$

Safety factor

safety factor = yield strength \div stress

$$= 455 \div 768.9$$

$$= 0.59$$

The above calculations do not take into consideration any added strength in the spar due to the rigidity of the paddles. The added strength is hard to determine, and is therefore ignored.

A safety shear key is recommended to protect the tuner from this condition. A section calculating the shear key size is included in this appendix (Shear strength in key in main gearbox drive shaft).

A.8. Torque calculations

**Twist loading on shaft due to centre of gravity not acting through the fixing flange
(Worst case, 100° paddle, inertia and weight torque combined)**

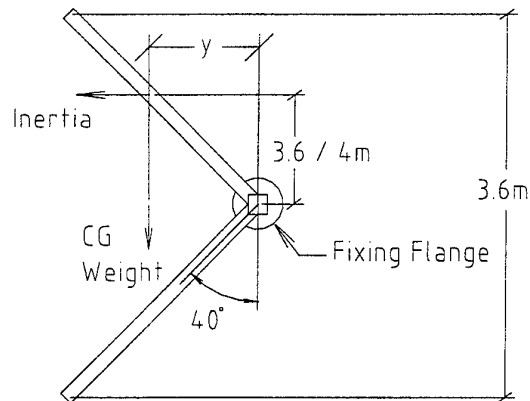

Figure A-11. Twisting load on fixing flange

Data

mass of paddle 'M' = 230kg
 weight of panel (230kg x 9.81) = 2256.3N
 weight of one side of paddle = 2256.3 ÷ 2 = 1128N
 total height of paddle = 3.6m
 height to centre of one side of paddle = 3.6 ÷ 4 = 0.9m
 inertia torque of one paddle = 1762.7Nm
 inertia torque of one side of paddle = 1762.7 ÷ 2 = 881.4Nm
 root thickness of weld = 5.6mm
 distance between welds 'l' = 125mm
 length of vertical weld = 125mm
 yield strength of welding rod = 455MPa
 yield strength of steel main shaft = 450MPa

torque load due to weight of panel
 distance C of G from axis of paddle 'y' = $\tan 40^\circ \times 0.9$
 = 0.839×0.9
 y = 0.755m

torque around paddle rotation axis due to weight = 0.755×1128
 = 851.6Nm

Torque load due to inertial

$$\text{distance C of G from axis of paddle} = 3.6 \div 4 = 0.9\text{m}$$

$$\begin{aligned} \text{torque around paddle rotation axis due to inertia} &= 0.9 \times 881.4 \\ &= 793.2\text{Nm} \end{aligned}$$

Total torque load

$$\begin{aligned} \text{total torque load} &= \text{inertial torque} + \text{weight torque} \\ &= 793.2 + 851.6 \\ &= 1644.8\text{Nm.} \end{aligned}$$

Load on weld at radius 62.5mm

$$\begin{aligned} \text{load on weld at radius } 0.0625\text{m} &= \text{torque} \div \text{radius of weld from centre of rotation} \\ &= 1644.8 \div 0.0625 \\ &= 26317\text{N} \end{aligned}$$

Only the welds on two sides of the square section (125mm by 125mm) stressed by the upper half of the paddle are considered. The welds on the other two faces will absorb the stresses from the lower half of the paddle.

$$\begin{aligned} \text{area of cross section of weld} &= \text{cross section of weld} \times \text{total length of weld} \\ &= 5.6 \times 125 \times 2 \\ &= 1400\text{mm}^2 \end{aligned}$$

Stress on weld due to torque

$$\begin{aligned} \text{stress on weld due to torque} &= \text{load} \div \text{area of weld} \\ &= 26317 \div 1400 \\ &= 18.8\text{MPa} \end{aligned}$$

Safety factor in torsion on weld

$$\begin{aligned} \text{safety factor} &= \text{yield strength} \times 0.6 \div \text{stress} \\ &= 455 \times 0.6 \div 18.8 \\ &= 14.5 \end{aligned}$$

Torsional load on weld between gearbox main shaft and drive flange (coupling to gearbox)

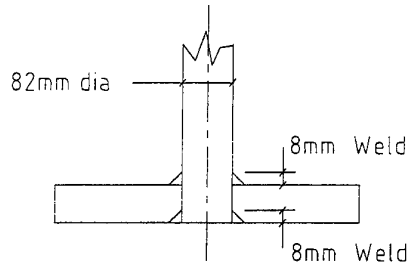

Figure A-12 Gearbox drive coupling

Data

root thickness of weld from Appendix A "General weld calculations"
 = 5.6mm
 yield strength of welding rod from reference [3]= 455MPa
 shear strength= 0.6 x yield strength
 normal operation torque from Appendix A "Torque required to accelerated tuner"
 = 7050.9Nm
 stall torque on gear box output shaft (from reference [2]) = 36042Nm
 diameter of shaft 'D'= 82mm (0.082m)

length of each weld= πD
 = $\pi \times 82$
 = 257.6mm

There are two welds (top and bottom of flange) so therefore length of weld = 515mm

Area of weld

area of weld = Cross section of weld x length of weld
 = 5.6 x 515
 = 2884mm²

Load on weld

load on weld = stall torque ÷ distance weld is from axis of rotation
 = 36042 ÷ (0.082 ÷ 2)
 = 879073N

Stress on weld

stress on weld = load ÷ area of weld
 = 879073 ÷ 2884
 = 304.8MPa

Safety factor

$$\begin{aligned} \text{safety factor using stall torque} &= \text{weld shear strength} \div \text{load stress} \\ &= 455 \times 0.6 \div 304.8 \\ &= 0.9 \text{ (used stall torque)} \end{aligned}$$

Weld stress for normal operation**Load on weld**

$$\begin{aligned} \text{load on weld} &= \text{normal operating torque} \div \text{distance weld is from axis of rotation} \\ &= 7050.9 \div (0.082 \div 2) \\ &= 17197\text{N} \end{aligned}$$

Stress on weld

$$\begin{aligned} \text{stress on weld} &= \text{load} \div \text{area of weld} \\ &= 17197 \div 2884 \\ &= 59.6\text{MPa} \end{aligned}$$

Safety factor or normal operating torque

$$\begin{aligned} \text{safety factor} &= \text{shear yield strength max strength} \div \text{load stress} \\ &= 455 \times 0.6 \div 58.6 \\ &= 4.6 \text{ (normal operating torque)} \end{aligned}$$

Recommendation

A safety-retaining ring is recommended to stop the assembly from toppling if the main shaft to flange weld fails. A sketch of this safety ring is shown in drawing SBGX050 Appendix B.

If the tuner jams and the full stall torque of the motor is applied to the drive shaft, the paddle spar will bend at the root of the spar and the spar webs. The safety factor is 0.59 (calculations are shown Appendix A "Torque calculations, Case 5: stress on spar cross section"). It is unlikely that the main shaft flange weld will fail, as the paddle spar will bend before weld failure. The consequence of failure of the main shaft flange weld is the tuner falling on to the equipment under test, so the installation of the safety retaining ring is still recommended.

Torsion load on main gear box shaft (82mm diameter)

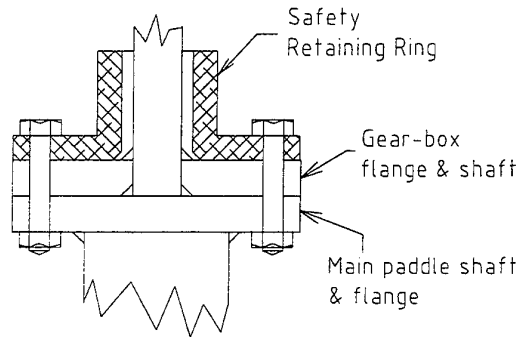

Figure A-13 Safety retaining ring

Maximum allowable stress at the outer-most fibre

$$S_s = (16 T) \div (\pi D^3) \quad \text{see reference [6] on page 15}$$

where

S_s = shearing (torsional) stress in outer-most fibre

T = torsion = stall torque on gear box output shaft = 36042Nm (from reference [2])

D = diameter of a round solid shaft = 82mm (0.082m)

$$S_s = (16 \times 36042) \div (\pi \times 0.082^3)$$

$$S_s = 576672 \div 0.0017322$$

$$S_s = 332.9\text{MPa}$$

The shaft material is unknown, so to obtain a representative figure, a hardness test was carried out on the shaft, see reference [5].

Average hardness main shaft 88.8HRB (hardness Rockwell B)

From reference [6], page 576, table AT 7, steel C1022 cold-rolled, has a hardness figure of 88 HRB, and has a tensile yield strength of 358MPa (52kpi).

Yield strength of material = 358MPa (from above)

$$\text{shear strength } S_s = \text{yield strength} \times 0.6$$

$$= 358 \times 0.6$$

$$= 215\text{MPa}$$

Safety factor

safety factor = shear yield strength max strength \div load stress

$$= 215 \div 332.9$$

= 0.65 (Note that this is calculated on the stall torque of the motor, with the normal operating torque being much lower.)

Normal operation

$$S_s = (16 T) \div (\pi D^3) \text{ see reference [6] on page 6}$$

where

T = torque = normal operational torque from gear box output shaft
 = 7050.9Nm (from Appendix A "Torque required to accelerate the tuner")

$$\begin{aligned} S_s &= (16 \times 7050.9) \div (\pi 0.082^3) \\ &= 112814.4 \div 0.0017322 \\ &= 65.1\text{MPa} \end{aligned}$$

Safety factor

safety factor = shear yield strength max strength \div load stress
 = 215 \div 65.1
 = 3.3

Torsional load on main shaft (150mm by 150mm, 6mm wall)

T = torque = $S_s J \div c$ see reference [6], page 15

Data

From Appendix A "Gearbox drive motor selection".
 new max torque at gearbox output shaft = 14,417Nm
 stall torque on gear box output shaft = 36,042Nm

The beam is 150mm square. From reference [4], structural steel hollow sections.

$$b = 150\text{mm}$$

$$b_1 = 138\text{mm}$$

$$h = 150\text{mm}$$

$$h_1 = 138\text{mm}$$

yield strength of material = 450MPa

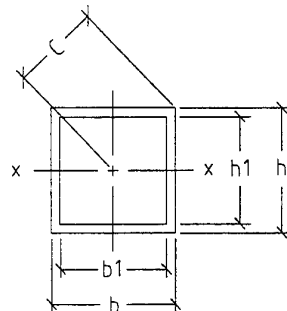

Figure A-14 Cross-section of main shaft

$$\text{Torque } T = (S_s J) \div c$$

where

T = applied torque 36042Nm (stall torque)

J = centroidal polar moment of inertia of the section about the neutral axis

c = distance from the neutral axis to the point where the stress is desired (maximum stress on an external fibre)

Polar moment of inertia formula taken from reference [7], page 176.

$$J = I_x = (bh^3 - b_1h_1^3) \div 12$$

J = polar moment of inertia for a hollow square section tube

$$\begin{aligned} &= (150 \times 150^3 - 138 \times 138^3) \div 12 \\ &= (506250000 - 362673936) \div 12 \\ &= 11964672\text{mm}^4 \end{aligned}$$

$$\begin{aligned} c &= 150 \div 2 \div \cos 45^\circ \\ &= 106\text{mm} \end{aligned}$$

$$\begin{aligned} S_s &= T c \div J \\ &= (36042 \times 1000 \times 106) \div 11964672 \\ &= 319.3\text{MPa} \end{aligned}$$

Safety factor (for motor stalled condition)

$$\begin{aligned} \text{safety factor} &= \text{yield strength} \div \text{load} \\ &= 450 \div 319.3 \\ &= 1.4 \end{aligned}$$

Normal operation

T = applied torque = 7050.9Nm (from Appendix A "Gearbox drive motor selection")

$$\begin{aligned} S_s &= T c \div J \\ &= (7050.9 \times 1000 \times 106) \div 11964672 \\ &= 62.5\text{MPa} \end{aligned}$$

Safety factor (for normal operation)

$$\begin{aligned} \text{safety factor} &= \text{yield strength} \div \text{load} \\ &= 450 \div 62.5 \\ &= 7.2 \end{aligned}$$

A.9. Shear Strength of Key in Main Gearbox Drive Shaft

Data

The key material is unknown, so to obtain a representative figure, a hardness test was carried out on the key, reference [5].

Average hardness main shaft 98.8HRB (hardness Rockwell B)

From reference [6], page 576, table AT 7, steel C1045 as rolled, gives a hardness figure of 96HRB, and has a tensile yield strength of 406MPa (59kpi).

tensile strength of key material = 406MPa

shear strength of key material $406 \times 0.6 = 243\text{MPa}$

normal operating torque = 7051Nm (from Appendix A "Torque required to accelerate tuner")

stall torque at gearbox output shaft = 36042Nm (from Appendix A "Gearbox drive motor selection")

diameter of Shaft = 82mm

distance key is from the centre of the shaft = 41mm

dimensions of key = 19mm by 19mm; 70mm long

thickness of gear = 50mm

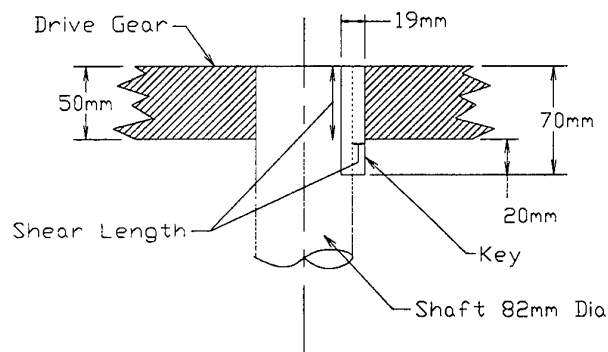

Figure 15 Showing shear length of key

$$\begin{aligned} \text{shear length of key} &= 50 + \text{half thickness of the key} \\ &= 50 + (19 \div 2) \\ &= 58.5\text{mm} \end{aligned}$$

$$\text{shear cross section of key } 19 \times 58.5 = 1111.5\text{mm}^2$$

$$\begin{aligned} \text{force to shear key} &= \text{material shear strength} \div \text{area} \\ &= 243 \div 1111.5 \end{aligned}$$

$$= 27009\text{N}$$

Max torque carrying capacity of the key

torque to shear key= shear force x distance key is from the centre of the shaft

$$= 270094 \times 0.041$$

$$= 11073.87\text{Nm}$$

Safety factor of key for normal operation

safety factor = $11074 \div 7051$

$$= 1.5$$

(This value is high for a shear key.)

Safety factor of key for stall condition (key in main drive gear)

safety factor = $11074 \div 36042$

$$= 0.31$$

(The key will shear when the tuner jams, ie. the motor stalls.)

Note:

For all cases where the tuner will otherwise fail (minimum calculated safety factor is 0.59 when the paddle jams), the installation of the safety shear key will prevent the failure from occurring. The weakest component in the system is the 82mm diameter, main gearbox shaft, which has a safety factor of 1.8 in the normal operating condition. As the method used to transmit the torque between the drive gear and the shaft is a tapered friction collet, and shear key mechanism, the force needed to shear the key would in reality be higher than the calculated 1.5. The main gearbox shaft also has a similar safety factor of 1.8, indicating that the shaft is likely to shear at approximately the same loading as the key. Reducing the length of the drive key so it acts as a safety shear key is recommended, thus protecting the system from overload. The recommended safety factor for the key under normal running conditions is 1.1.

Recommended length of key

torque = radius of applied load x Force at key radius due to normal operation torque

force at key = torque \div radius

$$= 7051 \div 0.041$$

$$= 171975\text{N}$$

Allowing for a safety factor of 1.1, new force = 171975×1.1

$$= 189173\text{N}$$

Force to shear key with a safety factor of 1.1 = 189173N

shear area of key = $19 \times$ length (L)

force to shear key = material shear strength x area

$$189173 = 243 \times 10^6 \times (0.019 \times L)$$

$$L = 189173 \div (0.019 \times 243 \times 10^6)$$

$$= 0.0409\text{m}$$

shear length to give a safety factor of 1.1 = 40.97mm

New length of key to give a safety factor of 1.1 under normal running conditions

41mm shear length required
 8.5mm half key thickness
 20mm length of key not engaged in gear

$$41 - 8.5 + 20 = 52.5\text{mm}$$

new length of key = 52.5mm (reduce present key length by 17.5mm)

Safety factor for new key length (52.5mm), for motor stalled condition

shear length of key to give a safety factor of 1.1 = 40.97mm
 force to shear key with a safety factor of 1.1 = 189173N
 shear strength of key material $406 \times 0.6 = 243\text{MPa}$
 stall torque at gearbox output shaft = 36042Nm (from Appendix A
 "Gearbox drive motor selection)

$$\text{cross section area to shear 52.5mm key } 40.97 \times 19 = 778.43\text{mm}^2$$

$$\begin{aligned} \text{force on shear key due to stall torque} &= \text{stall torque} \div \text{radius of shaft} \\ &= 36042 \div 0.041 \\ &= 879073\text{N} \end{aligned}$$

Safety Factor

$$\begin{aligned} \text{safety factor} &= \text{shear load} \div \text{stall torque load} \\ &= 189173 \div 879073 \\ &= 0.22 \end{aligned}$$

Safety factor for key length 52.5mm for motor stalled condition = 0.22 .

A.10. Stress on 'U' channel welds

Worst case is where the torque produced by the weight and the inertia is added. Stress is calculated for the condition when the top paddle is at 45° and the bottom paddle vertical. However, the top paddle at 45° is not the absolute worst case as the inertial force and weight is not equal. For the purpose of these calculations, the small error resulting from calculating the stress on the channel welds with the paddle at 45 degrees is compensated by a larger safety factor.

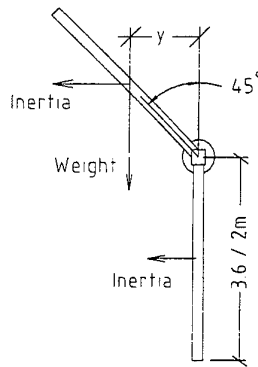

Figure A-16 Weight and inertia loads on 'U' channel welds

mass of one paddle (from Appendix A "Weight of each paddle")= 230kg
 weight of half a paddle (230 x 9.91 ÷ 2)= 1128N
 torque on half a paddle (from Appendix A "torque required to accelerate tuner")
 = 1762.7 ÷ 2 = 881.3Nm
 effective distance weight is from centre of paddle (45°). $y = \text{Cos } 45 \times 3.6 \div 4$
 = 0.64m

The combined torque on the welds exerted by the weight & the inertia.
 (weight x moment arm) + inertia torque = (0.64 x 1128) + 881 = 1603Nm

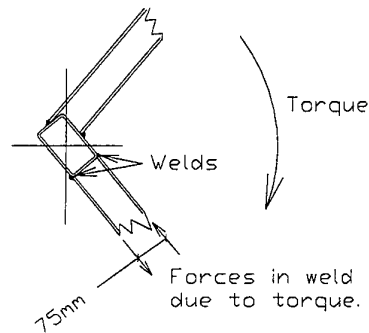

Figure A-17 U channel weld details

distance between welds = 75mm (0.075m)
 therefore load on weld = torque \div distance between welds
 = 1603 \div 0.075
 = 21373N

The inertial load plus weight load is transmitted from the paddle into the centre shaft via the support channel welds, and strengthening web welds.

Data

channel 75mm x 30mm, thickness of web 5mm
 yield strength of welding rod = 455MPa
 yield strength of channel = 450MPa

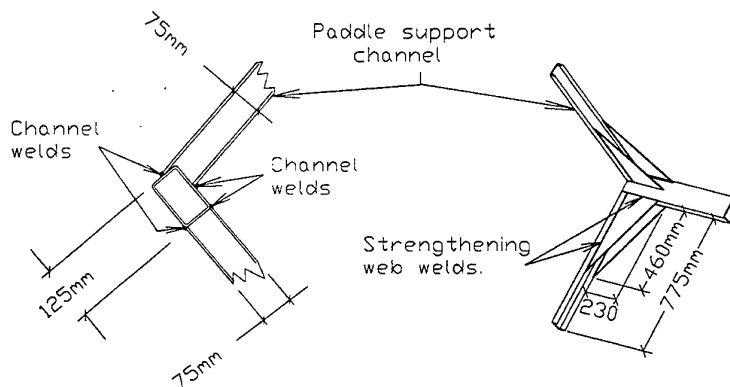

Figure A-18 U channel web & weld details

length of weld at the root of the paddle and main beam = 230 + 30
 = 260mm
 max depth of weld possible = 5mm
 cross section of weld = 260 x 5 = 1300mm²

Stress in weld

load = 21373N (from above)
 area = 1300mm² (from above)
 stress in weld = load \div area
 = 21373 \div 1300
 = 16.4MPa

Safety factor

safety factor = shear yield strength max strength \div load stress
 = 455 \div 16.4
 = 22.7

A.11. Fatigue calculations

Calculations of number of cycles

The average usage is assumed to be 1 revolution per day for 365 days per year. The worst case occurs when a revolution comprises of 400 steps. These estimations were given by K. Goldsmith.

From observation, it was estimated that during each stop, the paddle oscillates 4 cycles before coming to rest.

$$\begin{aligned}\text{number of cycles per year} &= 356 \times 4 \times 400 \\ &= 584,000 \text{ cycles/year.}\end{aligned}$$

Approximate life before fatigue has to be considered is 1,000,000 cycles.

Time taken for paddles to reach one million cycles.

$$1,000,000 \div 584,000 = \text{approx } 2 \text{ years.}$$

Since the anticipated life of the chamber is 6 years, fatigue life must be considered.

Fatigue stress on welds around paddle hub

The loads used for fatigue calculations are the loads encountered during normal running mode.

For normal operation stress in weld at hub = 20.1MPa (from Appendix A "Weld strength at root of hub and shaft", "stress on weld")

As the endurance strength of the material used is not known, a material of similar properties was selected. Endurance strengths were selected from reference [6], page 580, table AT 10.

S_n (fatigue strength) = 275.8MPa (40,000psi) Note that this is a conservative choice (wrought steel 1015).

From reference [6], page 103.

For long life the lower limit of fatigue strength for most materials is 24% lower than the average S_n .

$$\begin{aligned}\text{Therefore } S_n \text{ (fatigue strength for long life)} &= 275.8 - (275.8 \times 0.24) \\ &= 209.6\text{MPa}\end{aligned}$$

Actual stress (20.1MPa) is 10% of the allowable lower limit of fatigue stress (209.6MPa). Therefore fatigue in the paddle hub is not considered a problem.

Fatigue stress between weld at main shaft and coupling flange

For normal operation, stress in the weld joining the main shaft and coupling flange = 59.6MPa (from Appendix A "Torsional load on weld between gearbox main shaft and drive flange", "stress on weld")

As the endurance strength of the material used is not known, a material with similar properties was selected. Endurance strengths were selected from reference [6], page 580, table AT 10.

S_n (fatigue strength) = 275.8MPa (40,000psi) Note that this is a conservative choice. (wrought steel 1015)

From reference [6], page 103.

"For long life the lower limit of fatigue strength for most materials is 24% lower than the average S_n ."

therefore S_n (fatigue strength for long life) = $275.8 - (275.8 \times 0.24)$
= 209.6MPa

Actual stress (59.6MPa) is 28% of the allowable lower limit of fatigue stress (209.6MPa). Therefore fatigue in the weld joining the main shaft and coupling flange is not considered a problem.

Fatigue stress in gearbox main shaft

For normal operation, stress in the main gearbox shaft = 65MPa (from Appendix A "Torsional load on main gearbox shaft", "Normal operation")

As the endurance strengths of the material used is not known, a material of similar properties was selected. Endurance strengths were selected from reference [6], page 580, table AT 10.

S_n (fatigue strength) = 275.8MPa (40,000psi)

From reference [6], page 103.

S_n (fatigue strength) = $275.8 - (275.8 \times 0.24)$
= 209.6MPa

Actual stress, 65MPa, is 31% of the allowable lower limit of fatigue stress, 209.6MPa so fatigue in the main gearbox shaft is not considered a problem.

Fatigue summary

As the endurance strength data was not available for the steel used in the main shaft and weld material, an endurance strength was selected for a similar material with a similar yield strength. The actual stress is low compared to the allowable fatigue stress (31%, 28% & 10%), so inaccuracies in the choice of material are not considered significant.

The most likely area of failure of the shaft is at the end of the keyway at the top or the shaft where the main drive gear is located. If the shaft were to fail in this area, the tuner will still be held by the two main shaft bearings, so toppling of the tuner can not occur.

The other area of the shaft that is susceptible to a failure is the heat effected area next to the weld at the flange end of the drive shaft. If failure were to occur in this area, toppling of the tuner will be prevented by the installation of the recommended safety collar.

Appendix B: Drawings

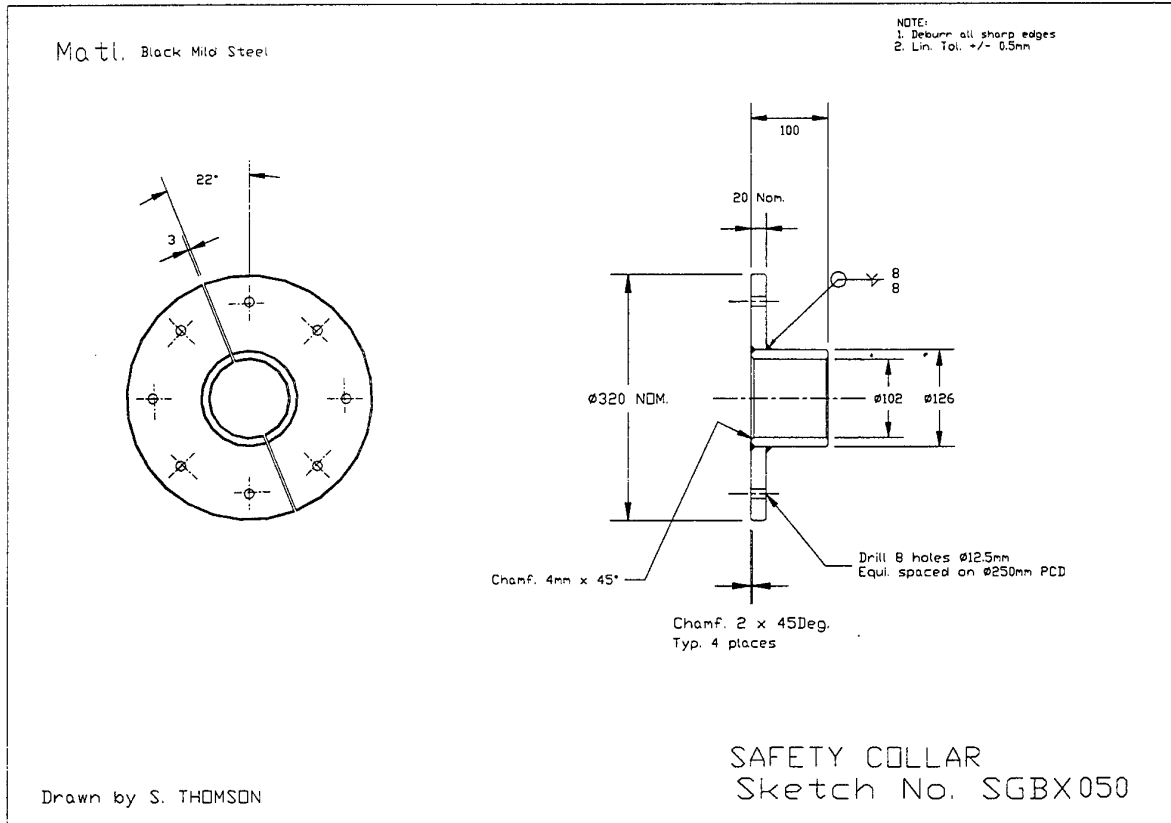

Sketch number SGBX 050

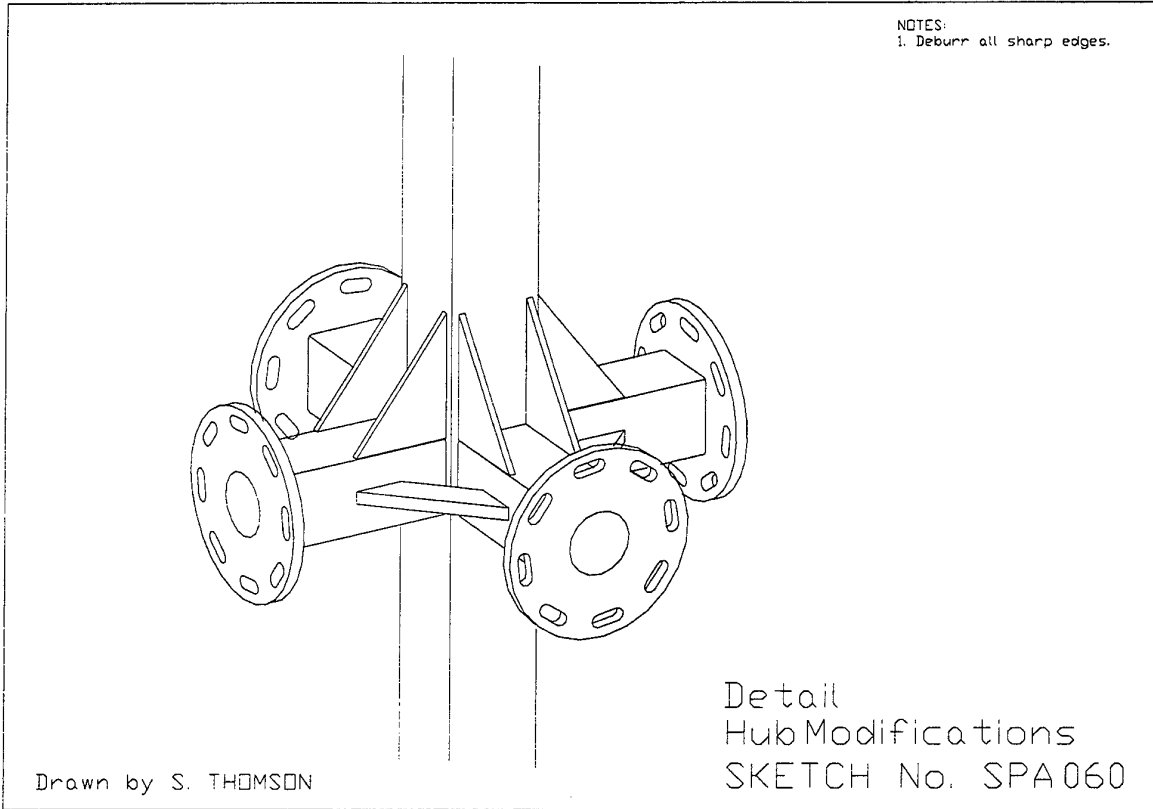

Sketch number SPA 060

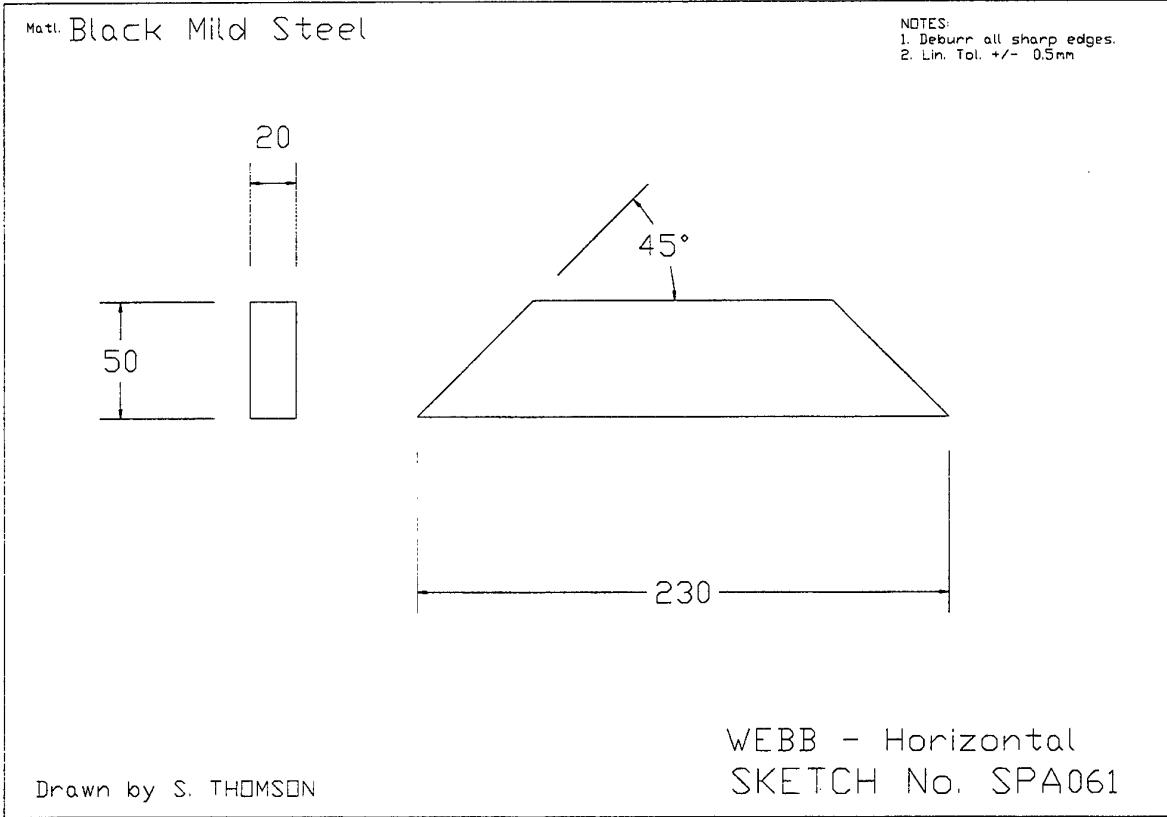

Sketch number SPA 061

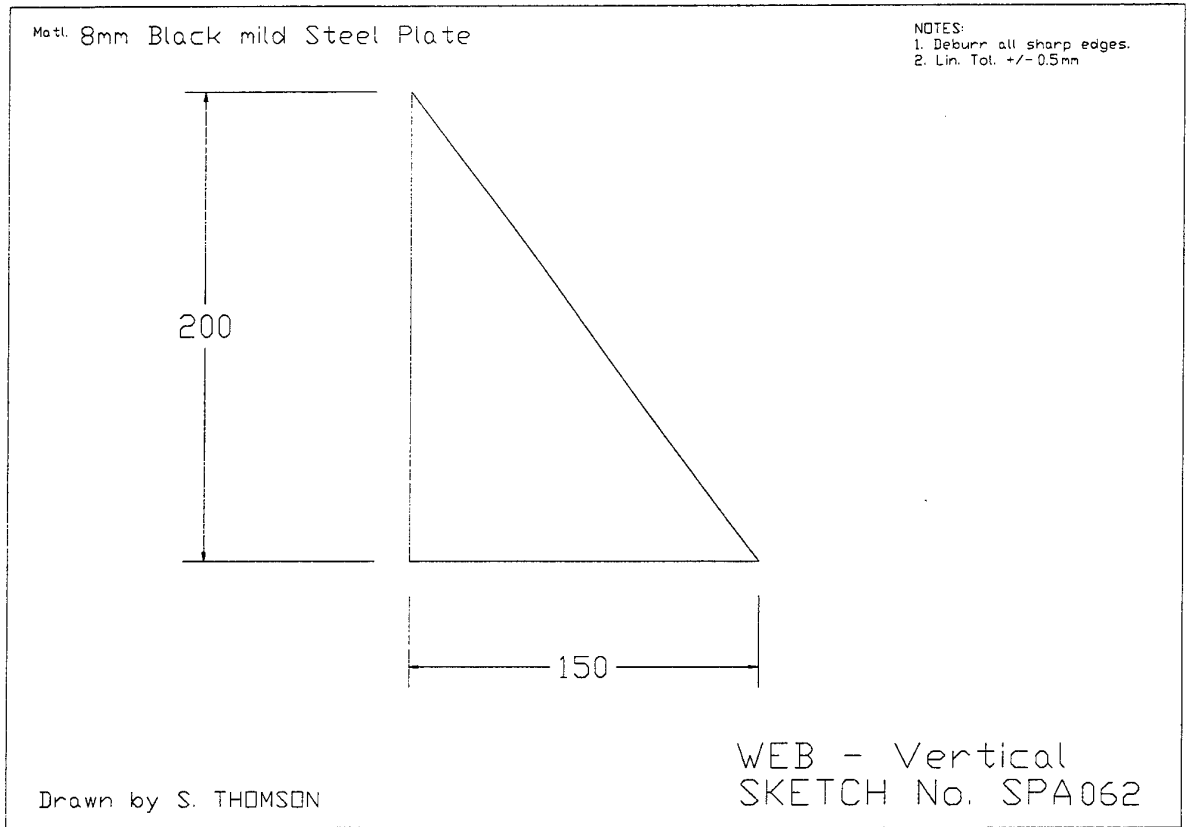

Sketch number SPA 062

DISTRIBUTION LIST

Stress Analyses of a Tuner for a Electromagnetic Reverberation Chamber

Frank Weeks

AUSTRALIA

DEFENCE ORGANISATION

Task Sponsor RAAF, DGTA

S&T Program

Chief Defence Scientist
FAS Science Policy
AS Science Corporate Management
Director General Science Policy Development
Counsellor Defence Science, London (Doc Data Sheet)
Counsellor Defence Science, Washington (Doc Data Sheet)
Scientific Adviser Policy and Command
Navy Scientific Adviser (Doc Data Sheet and distribution list only)
Scientific Adviser - Army (Doc Data Sheet and distribution list only)
Air Force Scientific Adviser
Director Trials

} shared copy

Aeronautical and Maritime Research Laboratory

Director
Chief of Air Operations division (AOD)
Research Leader RLAFM, N. Pollock
Head HAV, P. Urlings
Task Manager AIR97/123, K. Goldsmith
Author(s): F Weeks, Avionics, AOD

DSTO Library and Archives

Library Fishermans Bend
Library Maribyrnong
Library Salisbury (2 copies)
Library, MOD, Pyrmont (Doc Data sheet only)
US Defense Technical Information Center, 2 copies
UK Defence Research Information Centre, 2 copies
Canada Defence Scientific Information Service, 1 copy
NZ Defence Information Centre, 1 copy
National Library of Australia, 1 copy

Capability Systems Staff

Director General Maritime Development (Doc Data Sheet only)
Director General C3I Development (Doc Data Sheet only)
Director General Aerospace Development

Air Force

SCI2, LSA, M.Wade1
SCI2a, LSA, FLTLT G.Gallagher

Intelligence Program

DGSTA Defence Intelligence Organisation
Manager, Information Centre, Defence Intelligence Organisation

Corporate Support Program

OIC TRS, Defence Regional Library, Canberra

UNIVERSITIES AND COLLEGES

Australian Defence Force Academy
Library
Head of Aerospace and Mechanical Engineering
Hargrave Library, Monash University (Doc Data Sheet only)
Librarian, Flinders University

OTHER ORGANISATIONS

NASA (Canberra)
Info Australia (formerly AGPS)

OUTSIDE AUSTRALIA**ABSTRACTING AND INFORMATION ORGANISATIONS**

Library, Chemical Abstracts Reference Service
Engineering Societies Library, US
Materials Information, Cambridge Scientific Abstracts, US
Documents Librarian, The Center for Research Libraries, US

INFORMATION EXCHANGE AGREEMENT PARTNERS

Acquisitions Unit, Science Reference and Information Service, UK
Library - Exchange Desk, National Institute of Standards and Technology, US
National Aerospace Laboratory, Japan
National Aerospace Laboratory, Netherlands

SPARES (5 copies)

Total number of copies: 48

DEFENCE SCIENCE AND TECHNOLOGY ORGANISATION DOCUMENT CONTROL DATA				1. PRIVACY MARKING/CAVEAT (OF DOCUMENT)	
2. TITLE Stress Analyses of a Tuner for an Electromagnetic Reverberation Chamber			3. SECURITY CLASSIFICATION (FOR UNCLASSIFIED REPORTS THAT ARE LIMITED RELEASE USE (L) NEXT TO DOCUMENT CLASSIFICATION) Document (U) Title (U) Abstract (U)		
4. AUTHOR(S) Frank Weeks			5. CORPORATE AUTHOR Aeronautical and Maritime Research Laboratory PO Box 4331 Melbourne Vic 3001 Australia		
6a. DSTO NUMBER DSTO-TN-0272		6b. AR NUMBER AR-011-423	6c. TYPE OF REPORT Technical Report		7. DOCUMENT DATE February 2000
8. FILE NUMBER M1/9/612	9. TASK NUMBER Air 97/ 123	10. TASK SPONSOR RAAF DGTA	11. NO. OF PAGES 51		12. NO. OF REFERENCES 8
13. URL http://www.dsto.defence.gov.au/corporate/reports/DSTO-TN-0272.pdf			14. RELEASE AUTHORITY Chief, Air Operations Division		
15. SECONDARY RELEASE STATEMENT OF THIS DOCUMENT <i>Approved for public release</i>					
OVERSEAS ENQUIRIES OUTSIDE STATED LIMITATIONS SHOULD BE REFERRED THROUGH DOCUMENT EXCHANGE, PO BOX 1500, SALISBURY, SA 5108					
16. DELIBERATE ANNOUNCEMENT No Limitations					
17. CASUAL ANNOUNCEMENT Yes					
18. DEFTEST DESCRIPTORS Tuners, Structural analysis, Electromagnetic environment, Recommendations					
19. ABSTRACT Structural analyses of a tuner for a large electromagnetic reverberation chamber are presented in this note. The analyses cover drive motor, highly stressed welds of the paddle assembly, torque in drive shafts, and weld fatigue life. The analyses have been conducted for normal operating conditions as well as for a variety of possible overload conditions. Recommendations for minor modifications are made, including the installation of a safety collar.					