

# *Environmental Effects of Dredging Technical Notes*



## **Development of Laboratory Procedures to Predict Volatile Losses from Contaminated Sediments**

### **Purpose**

This technical note describes the development of laboratory procedures to obtain experimental data on the emission of volatile organic chemicals (VOCs) from exposed sediment. These data are being used to develop and validate predictive volatile emissions models. The information presented herein includes laboratory techniques and some preliminary results obtained during these investigations.

### **Background**

Contaminated sediments and dredged materials can be sources for emissions of volatile compounds, many of which are in high concentrations in these materials. This phenomenon is becoming increasingly recognized as a potential environmental problem. Previous investigations conducted with sediment from New Bedford Harbor, Massachusetts, showed that large amounts of VOCs are emitted from sediments when the material is disturbed and exposed to air.

The factors affecting volatile losses are largely unknown. Methods for predicting volatile losses from sediments during the different phases of dredging and disposal operations are needed to develop guidelines for controlling possible contaminant volatile emissions. Presently, neither field data nor models exist to accurately predict VOC emissions under different environmental and operational conditions.

**DISTRIBUTION STATEMENT A**  
Approved for Public Release  
Distribution Unlimited

20000822 191

US Army Engineer Waterways Experiment Station  
3909 Halls Ferry Road, Vicksburg, MS 39180-6199



DMC QUALITY INSPECTED 4

AQM00-11-3490

## Additional Information

For further information contact one of the authors, Ms. Cynthia Price, (601) 634-3621, Dr. James Brannon, (601) 634-3725, Mr. Tommy Myers, (601) 634-3939, Dr. K. T. Valsaraj, (504) 388-1426, Dr. Louis Thibodeaux, (504) 388-1426, Dr. Danny Reible, (504) 388-1426, or the manager of the Environmental Effects of Dredging Programs, Dr. Robert M. Engler, (601) 634-3624.

## Introduction

Dredging and disposal of contaminated sediments can pose significant environmental problems. During dredging operations and storage of sediments in confined disposal facilities (CDFs), there is increased opportunity for VOCs to be emitted from contaminated dredged materials. Exposed sediments are a primary volatile contaminant pathway (Figure 1).

Sediments stored in CDFs undergo cyclic "wet/dry" conditions and also experience varying conditions of temperature and relative air humidity. Organic compound volatilization from sediments is affected by sediment moisture, temperature, and relative humidity.

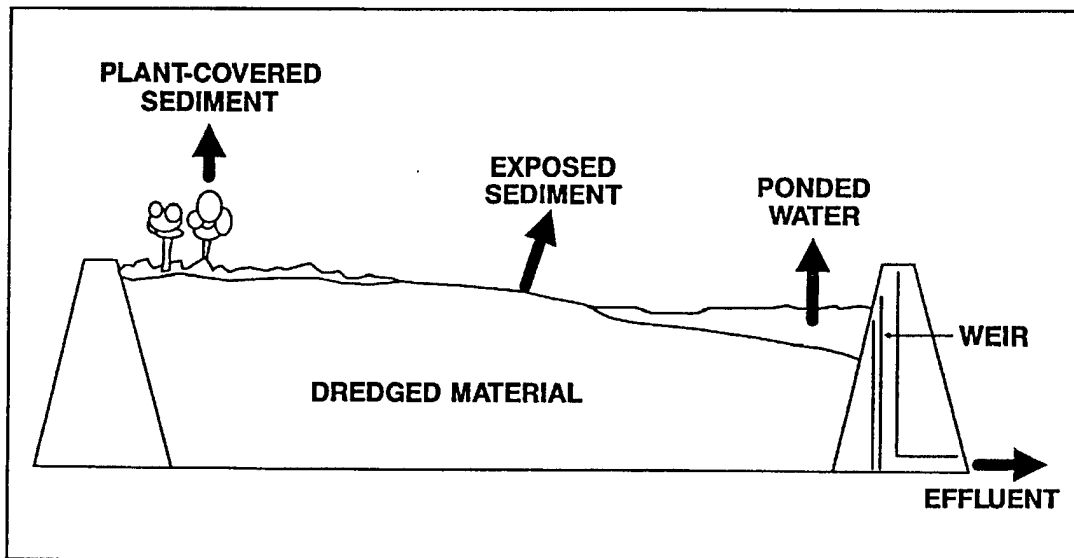

Figure 1. Pathways for release of volatile emissions from dredged material

Valsaraj and Thibodeaux (1988) found that moisture content strongly affects the sorptive capacity of sediments. Dry sediments have an increased sorptive capacity for hydrophobic organic compounds. As sediment moisture or relative air humidity increases, water molecules will displace the hydrophobic compounds, thereby decreasing sediment sorptive capacity and increasing possible emission of these compounds.

Mathematical models have been proposed to estimate the air emission rates of various volatile organic compounds (Thibodeaux 1989). These models remain untested due to the lack of both laboratory and field experimental data needed to develop and validate the models. Laboratory procedures developed at the Waterways Experiment Station are identifying and quantitating the factors affecting VOC losses from exposed sediments to test and refine these theoretical models.

## Materials and Methods

### Sediment

The sediment used in laboratory testing was obtained from the Rouge River, Michigan. It is contaminated with several polycyclic aromatic hydrocarbons (PAHs). For experimental purposes, only three compounds were looked at during the investigations. These compounds were pyrene, phenanthrene, and dibenzofuran.

### Flux Chambers

A modification of a test chamber designed by Spencer and others (1979) was used in all laboratory tests to estimate the VOC emissions from the Rouge River sediment (Figure 2). The chamber is constructed of anodized aluminum blocks (2.54 cm deep, 30 cm long, 9 cm wide). The lower block contains a well (10 cm long, 3 cm wide, 2.54 cm deep) in which the sediment is placed. The upper block contains a 10-cm-long by 3-cm-wide opening, lined on the bottom

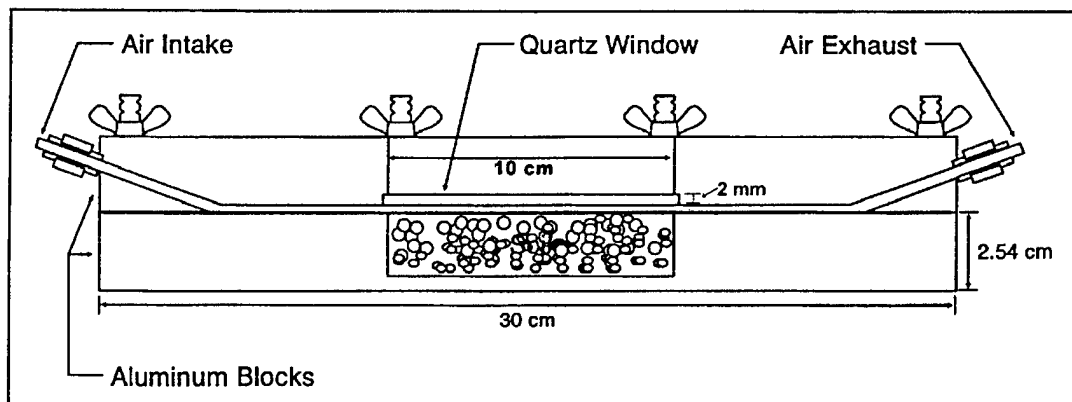

Figure 2. Schematic of volatiles test chamber

with a quartz glass sheet 0.32 cm thick. The upper block is grooved to provide a 2-mm air space above the soil for air flow.

### **Determination of Flux**

Ten chambers were used in parallel to ensure adequate surface area for attaining detectable levels of hydrocarbons on the trapping material. Each chamber was loaded with approximately 18 g of sediment and sealed. Compressed air, channeled through Gilmont flowmeters, was used to standardize air flow rates for all 10 chambers.

The relative humidity of the air stream was controlled for some of the tests by bubbling air through a water trap at different flow rates and by using an in-line Tri-Sense relative humidity meter and probe to monitor the air humidity entering the chambers.

Attached to each chamber was a stainless steel tube (11.4 cm long by 0.32 cm wide) packed with 0.15 g Florisil. Glass wool was used to hold the trapping material in the tubes.

At specified sampling intervals, the traps were removed from the test chambers and extracted with 10 ml of a 50 percent methylene chloride/46 percent hexane/4 percent acetonitrile mixture. The extracts from all 10 chambers were composited and reduced in total volume to 10 ml using nitrogen blowdown. Analysis was performed using standard method 8310 (U.S. Environmental Protection Agency 1982).

## **Tests and Results**

### **Flow Tests**

Two experiments were conducted to determine the effect of flow rate on the emission rates of the PAH compounds. Flows of 10, 100, and 1,000 ml/min were used.

In the first experiment, an initial flow rate of 10 ml/min was sustained for a period of 7 days. The flow rate was then increased to 100 ml/min for a period of 36 hr, after which the flow was increased to 1,000 ml/min for another 8 hr.

A second experiment was conducted to verify the results obtained in the first experiment. The initial flow rate of 10 ml/min was sustained for 3 days instead of 7 days. The flow was then increased to 100 ml/min for 36 hr, and again to 1,000 ml/min for 8 hr as in the previous test. Traps were sampled intermittently during each sampling period at each flow rate.

The resulting data revealed that the fluxes of dibenzofuran and phenanthrene during the first time period, with a flow rate of 10 ml/min, were controlled by air side resistance (Valsaraj and others, in press), with the flux

remaining constant during this time. When the flow rate was increased to 100 ml/min, there was a corresponding decrease in the air side resistance, resulting in an increased flux of both compounds (Figure 3).

Following the 100 ml/min rate test, the flow was increased to 1,000 ml/min. Virtually no increase in flux rates was noted, signifying that soil side resistance had become the controlling factor at this high flow rate.

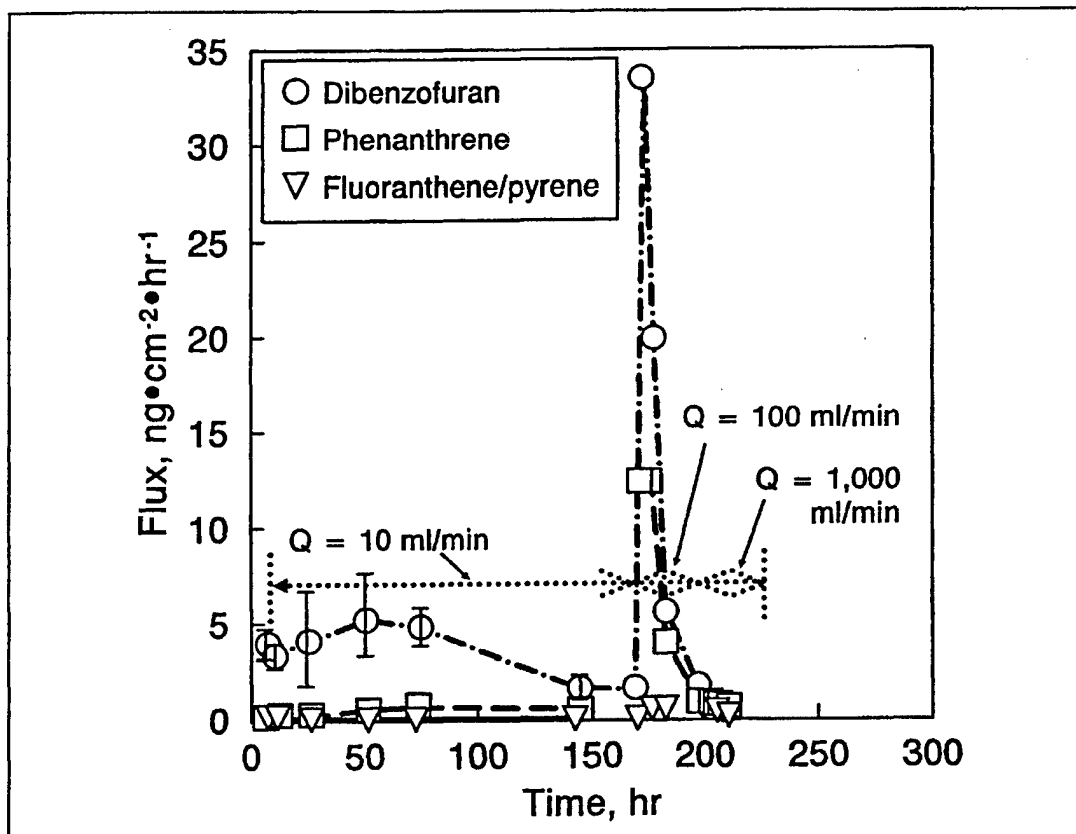

Figure 3. Effect of flow rate on contaminant flux (Q), Rouge River sediment

### Relative Humidity Tests

Based on results from the flow rate experiments, 100 ml/min was used as the flow rate for all additional testing. The experiments were conducted to study the emission of volatile organic compounds from sediment over which air at varying relative humidities was passed to simulate conditions that might occur at a CDF during natural wet/dry cyclic conditions.

A total of seven experiments were conducted using relative humidities of 0 and 100 percent. An example of a test run is as follows. "Dry" air at 0 percent relative humidity was passed over the surface of the sediment for a predetermined amount of time, after which the air humidity was changed to 100 percent and further samples were taken.

Results revealed an initial increase in contaminant fluxes as the "dry" (0 percent relative humidity) air was passed over "wet" sediment (24 percent moisture) (Figure 4). The fluxes decreased to a steady state as the surface of the sediment dried. When the air humidity was increased, an immediate increase in flux was noted with a corresponding decrease to a slightly higher steady-state flux than with the "dry" air.

These results show that when the "dry" air passes over a dry sediment surface layer, there is little competition for sorption sites and flux is therefore decreased to a low value. When the air humidity is increased, the water molecules act to displace the sorbed PAH compounds that had diffused to the surface under dry conditions, and the flux is subsequently increased.

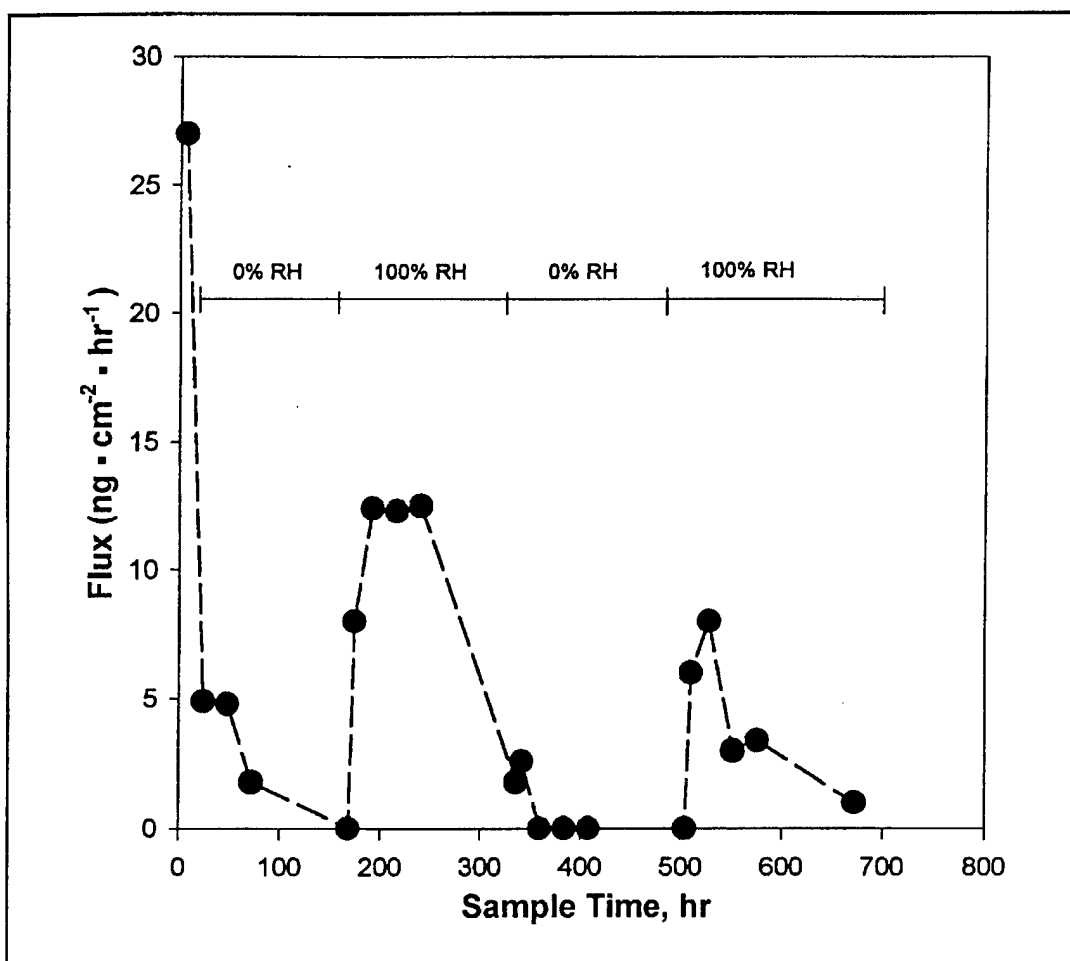

Figure 4. Dibenzo(a,h)anthrene flux from Rouge River sediment, with varying percentage relative humidity (RH) of air

## Conclusions

Testing to date has shown that flow rate, which can be converted to wind speed and air humidity, affects release of VOCs from exposed sediment. Laboratory investigations have also shown that the surface area of the test chambers is inadequate, requiring the use of 10 chambers in parallel to quantify VOC flux rates.

Larger experimental chambers, with more than 10 times the surface area of the small chamber, have been constructed. The larger test chambers will allow simultaneous replication of tests and the use of a single trap for VOCs instead of combining the extract from 10 traps to make a single sample.

Testing of the large chambers for air flow and other engineering qualities is ongoing. Following any necessary modifications, testing of the factors affecting VOC emissions from exposed sediments will continue.

## References

- Spencer, W. F., Shoup, T. D., Cliath, M. M., and Haque, R. (1979). "Vapor pressure and relative volatility of ethyl and methyl parathion," *Journal of Agricultural and Food Chemistry* 27(2), 273-78.
- Thibodeaux, Louis J. (1989). "Theoretical models for evaluation of volatile emissions to air during dredged material disposal with applications to New Bedford Harbor, Massachusetts," Miscellaneous Paper EL-89-3, U.S. Army Engineer Waterways Experiment Station, Vicksburg, MS.
- U.S. Environmental Protection Agency. (1982). "Test methods for evaluating solid waste—physical and chemical methods," SW-846, 2d ed., National Technical Information Service, Springfield, VA (NTIS No. PB87-120291).
- Valsaraj, K. T., and Thibodeaux, J. (1988). "Equilibrium adsorption of chemical vapors on surface soils, land fills and land farms — A review," *Journal of Hazardous Materials* 19, 79-99.
- Valsaraj, K. T., Thibodeaux, L. J., Reible, D. D., Brannon, J. M., Myers, T. E., and Price, C. B. "Air emissions from exposed, contaminated sediments and dredged materials; 1. Experimental data in laboratory microcosms and mathematical modelling," *Journal of Hazardous Materials* (in press).

## INTERNET DOCUMENT INFORMATION FORM

**A . Report Title: DEVELOPMENT OF LABORATORY PROCEDURES TO PREDICT VOLATILE LOSSES FROM CONTAMINATED SEDIMENTS**

**B. DATE Report Downloaded From the Internet: 08/15/00**

**C. Report's Point of Contact: (Name, Organization, Address, Office Symbol, & Ph #):**  
US Army Engineer Waterways Experiment Station  
Environmental Laboratory  
PO Box 631  
Vicksburg, Mississippi 39181-0631

**D. Currently Applicable Classification Level: Unclassified**

**E. Distribution Statement A: Approved for Public Release**

**F. The foregoing information was compiled and provided by:**  
DTIC-OCA, Initials: LF Preparation Date 08/21/00

The foregoing information should exactly correspond to the Title, Report Number, and the Date on the accompanying report document. If there are mismatches, or other questions, contact the above OCA Representative for resolution.