

LOAN DOCUMENT

PHOTOGRAPH THIS SHEET

DTIC ACCESSION NUMBER

LEVEL

INVENTORY *D*

*Electro-optic Polymers and Applications in
Phase Shifters for Next Generation Phase
array Antennas*

DOCUMENT IDENTIFICATION

DISTRIBUTION STATEMENT A
Approved for Public Release
Distribution Unlimited

DISTRIBUTION STATEMENT

ACCESSION FOR	
NTIS	GRAM
DTIC	TRAC
UNANNOUNCED	
JUSTIFICATION	
BY	
DISTRIBUTION/	
AVAILABILITY CODES	
DISTRIBUTION	AVAILABILITY AND/OR SPECIAL
<i>A-1</i>	

DISTRIBUTION STAMP

DATE ACCESSIONED

DATE RETURNED

REGISTERED OR CERTIFIED NUMBER

20000814 182

DATE RECEIVED IN DTIC

REGISTERED OR CERTIFIED NUMBER

PHOTOGRAPH THIS SHEET AND RETURN TO DTIC-FDAC

H
A
N
D
L
E
W
I
T
H
C
A
R
E



**Electro-optic Polymers and Applications in Phase Shifters
for Next Generation Phase Array Antennas**



Unclassified

W. H. Steier, M. C. Oh, C. Zhang, H. Zhang, A. Szep
University of Southern California

H. R. Fetterman, Y. Chang, H. Erlig, B. Tsap
University of California, Los Angeles

L. R. Dalton
University of Southern California
University of Washington

C. Lee
Air Force Office of Scientific Research

Unclassified

1

Electro-optic polymers in traveling wave modulators have the potential for very wide band operation (>100 GHz) due to the low dielectric constant of the polymers and in addition very low voltage drive requirements because of the high EO coefficients promised by the polymer chemists. Recent advances in the understanding of dipole-dipole interactions and new techniques in modulator fabrication have resulted in modulators which realize this potential. We report here on polymer traveling wave modulators with $V_{\pi}(\text{dc}) = 2.6\text{V}$ @ 1310 nm and $V_{\pi}(\text{dc}) = 3.9\text{V}$ @ 1550 nm and operating to 60 GHz and greater. The high thermal stability (90°C) and low propagation loss (1-2 dB/cm) of these devices make them commercially viable. Using a similar polymer and a push-pull design a $V_{\pi} = 0.8\text{V}$ has been achieved using an electrode design which is compatible with high frequency operation. These polymers can also be used to fabricate an integrated rf photonic phase shifter. In this device an rf signal is modulated onto an infrared carrier and the phase of the rf modulation is controlled by an additional dc electrode. We will review the properties of the phase shifter fabricated in EO polymers. We will also present its use as the phase control element in a phased array antenna.

*Approved for Public Release;
Distribution is Unlimited.*

Unclassified



**Electro-optic Polymers and Applications in Phase Shifters
for Next Generation Phase Array Antennas**



Unclassified

CONTENTS

- A. Overview of electro-optic polymers and material status**
- B. Review of high speed optical modulators**
 - Applications**
 - Current status**
- C. Application of EO polymers to photonic rf phase shifters**
- D. Next generation phased array antennas**

Unclassified

2

Unclassified

ORGANIC MOLECULES FOR NON-LINEAR OPTICS

Unclassified

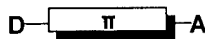

$$E(t)$$

$$P(t) = \epsilon_0 \chi E(t) + 2d[E(t)]^2$$

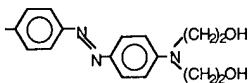

Azo dye

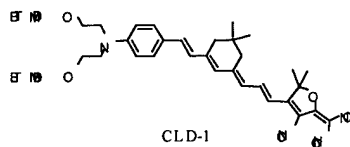

CLD-1
Tri-cyano dye

- A. Include in polymer matrix
- B. Spin Films
- C. Align molecules in E filed at high temperature $\sim 150^\circ\text{C}$

Leads to:

- A. Second harmonic generation
 - B. Electro-optic effect
- $$\Delta n = 1/2 n^3 r E(t)$$

Unclassified

3

Molecules which exhibit an electro-optic effect have been known and studied for some time. These molecules are traditionally rod shaped with a donor complex on one end and an acceptor complex on the other. They therefore have a large electric dipole moment and exhibit a second order nonlinear optical effect. For application, the molecules are placed in a host material and polymers are a particularly promising host. The polymers can be spin cast and their optical and electrical properties can be controlled by synthesis. After the polymer films are spun, the molecules must be aligned and this is done by applying a large electric field while the sample is at a high temperature.

Unclassified

Unclassified

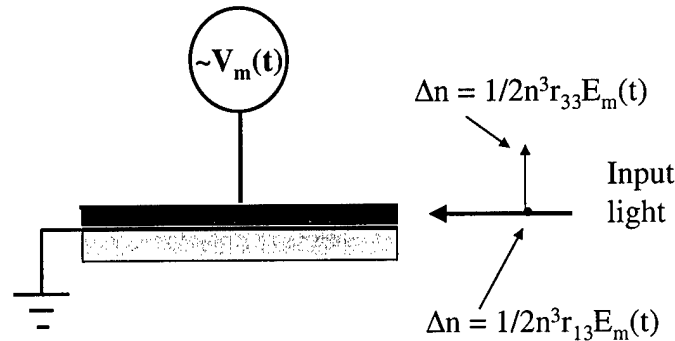

- Very high bandwidth, low voltage infrared modulators (~100 GHz)
- Photonic rf phase shifters for phased array antennas
- Integration of optical switches and modulators with high speed electronics and other photonic devices on the same chip. 4

Unclassified

We are interested in the electro-optic effect of these polymers where the optical index of refraction can be changed by an applied electric field. This is the basis for high speed infrared modulation. As shown, the modulating field is applied perpendicular to the aligned films and the light to be modulated has its polarization perpendicular to the film. This makes use of the larger r_{33} EO coefficient. Using this approach very wide band and low voltage modulators have been demonstrated.

Unclassified

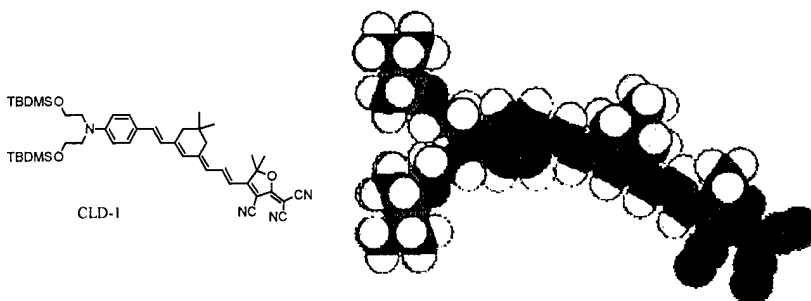

- $\mu\beta = 20,000$
- $\lambda_{\max} = 632 \text{ nm}$
- $T_d = 275 \text{ }^\circ\text{C}$

Unclassified

5

It has recently been realized by Dalton, et al. That one of the problems that has prevented the full nonlinear property of the molecules from being realized is the dipole-dipole interaction between the dipoles when they are in the polymer matrix. To prevent the dipoles from locking themselves into counter alignment, the molecules must be sterically designed with side structures to prevent their close approach. Shown is the latest molecule which has been designed on this basis. This molecule, CLD, is used in all of the high speed modulators reported here.

Unclassified

Electro-optic Coefficient of CLD/APC

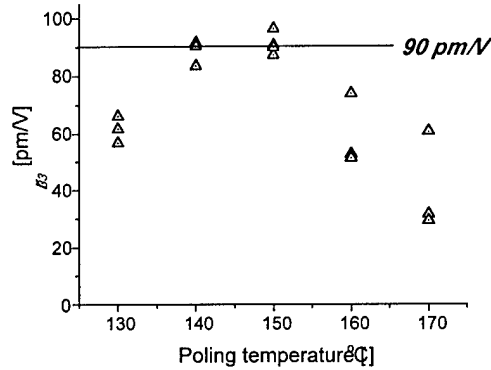

- Single layer on ITO glass
- Corona poling by 8 kV for 30 min.
- EO coefficient measured from ATR
- Optimum poling temperature : 140 - 150 °C
- 90 pm/V achieved at 1.06 mm wavelength
- Extrapolates to 60 pm/V @ 1300 nm
45 pm/V @ 1550 nm

This shows the measured EO coefficient of the CLD molecule in a polycarbonate host polymer (APC). The CLD/APC material has one of the highest EO coefficients measured in the IR wavelength range. The measurements are at 1060 nm and can be extrapolated to the important 1300 nm and 1550 nm range. The dipole alignment in this material is stable to ~ 100°C. The molecules and the host are chemically stable to ~ 300°C.

Schematic of High Speed MZ Modulator

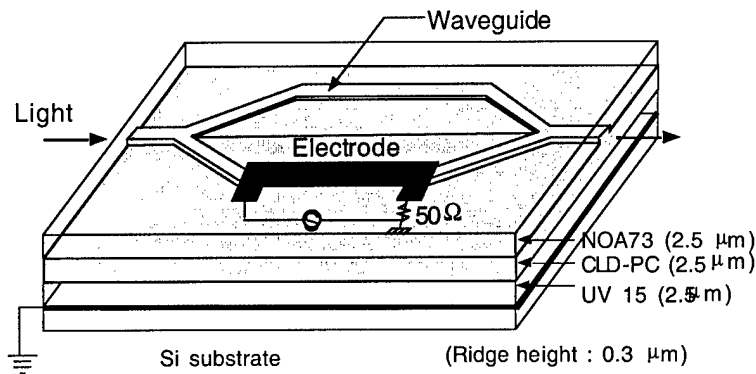

This shows the typical traveling wave polymer modulator, The design is the Mach Zehnder amplitude modulator. The infrared travels in the buried ridge waveguide and the high speed modulating signal travels on the micro-strip line. The modulation occurs as the two wave are co-propagating in one arm of the interferometer.

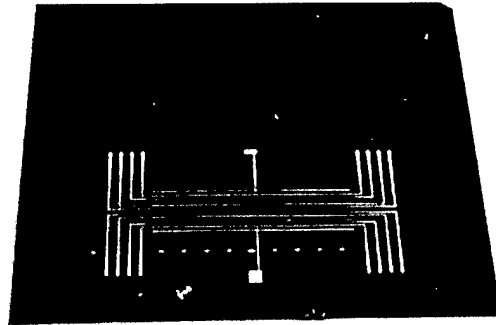

Eight modulators on silicon substrate

Unclassified

8

Photograph of a completed modulator chip. Eight modulators are fabricated on a single Si chip. The modulators are ~2.5 cm long. For packaging the modulators are separated, fibers are bonded onto each end, and rf connectors are attached to the package.

Unclassified

CLD/APC EO Polymer Material and Modulator Results

LABORATORY MATERIAL

- $r_{33} = 60 \text{ pm/V@ } 1300 \text{ nm}, 45 \text{ pm/V@ } 1550 \text{ nm}$
- Long term thermal stability of poling to 90-100°C
- Waveguide propagation loss = 1.7 dB/cm @ 1550 nm

LABORATORY MODULATORS

- Measured V_{π} : 2.4 V@1300nm; 3.7 V@1550nm
- r_{33} in the device : 47 pm/V @ 1300 nm; 36 pm/V @ 1550nm
~ 70% of single layer measurement; likely due to conductivity of the claddings
- Extinction ratio : 26 dB (strictly single mode waveguide)

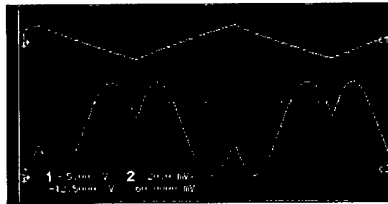

Review of the current status of the laboratory polymer materials and the laboratory modulators fabricated from these materials. The low frequency electro-optic modulation response of the device was measured by applying a 1-kHz electrical signal with a saw-tooth waveform. For the MZ modulator with a 2-cm long electrode, the V_{π} was measured to be 2.4 V, which is corresponding to an r_{33} of 47 pm/V at 1300 nm. At 1550 nm, the V_{π} was 3.7 V with the corresponding r_{33} of 36 pm/V. The EO modulation response is shown in the figure. The electro-optic coefficient in the modulators is about 70% of the value measured from the single layer films. We believe the poling was not as efficient in the modulator due to the difference in electrical conductivity of the core and lower cladding at the poling temperature. If a different cladding material with lower resistivity at the poling temperature is used, it should be possible to further decrease the V_{π} . The extinction ratio of the MZ modulator was greater than 20 dB which indicates that the waveguide is single mode.

**INITIAL FREQUENCY RESPONSE MEASUREMENT
OF UN-PACKAGED CLD- APC MODULATOR**

Unclassified

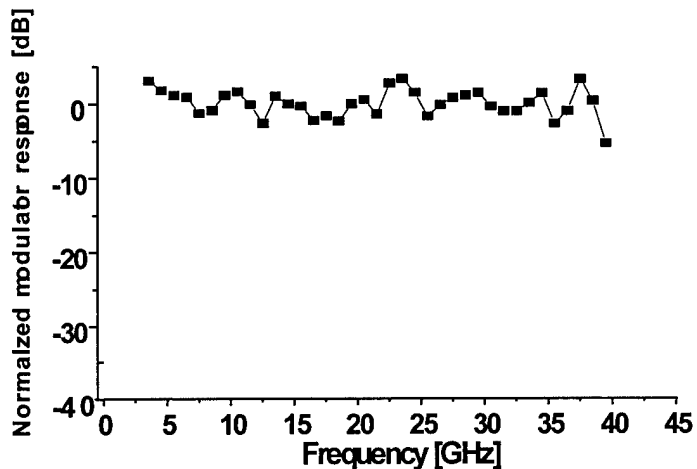

Unclassified

10

Because of the low dielectric constant of the EO polymers, the traveling wave devices can easily operate at millimeter-wave frequencies. This shows the operation of one of the un-packaged modulators operating out to 40 GHz. To confirm the high frequency operation of the fabricated devices, the optical response was measured using a optical spectrum analyzer from 2 GHz to 40 GHz. In the frequency range from 2 to 20 GHz, the optical signal dropped by 1.5 dB. In earlier work we demonstrated a polymer modulator operating to 113 GHz. The optical 3 dB bandwidth of these devices is typically determined by the millimeter-wave loss on the micro-strip line.

Unclassified

MODULATOR WITH BALANCED OUTPUT USING APC/CLD

$V_{\pi}(1300\text{nm}) = 2.3\text{V}$
Extinction Ratio $\sim 20\text{dB}$

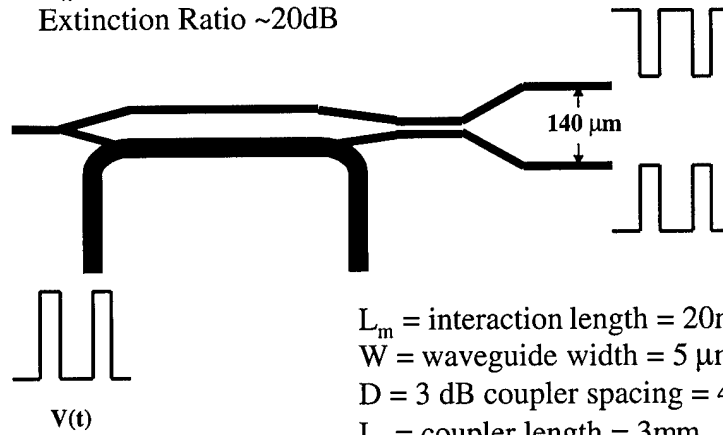

L_m = interaction length = 20mm
 W = waveguide width = 5 μm
 D = 3 dB coupler spacing = 4 μm
 L_c = coupler length = 3mm 11

Unclassified

High speed electro-optic modulators with a balanced output have several applications in rf photonics and switching systems. This device combines a Mach Zehnder modulator with a 3 dB waveguide coupler. Voltage applied to the modulator electrode switches the output light between the two output waveguides. To achieve a high contrast, that is, to switch all of the light between the two outputs, requires the coupler to be as close to 3 dB as possible. We have been able to achieve greater than -20 dB contrast. Using the new polymer materials the devices have a switching voltage of 2.4 V at 1300 nm.

We are now considering the applications of these switches to rf photonic systems using a balanced output for noise suppression. We are also designing the integration of the switches with waveguide delay lines to build an integrated real time delay network for antenna arrays.

Unclassified



STATUS OF EO POLYMER MODULATORS



Unclassified

- ★ Commercial high speed modulator will be available for testing from Pacific Wave Industries, Inc.
 - Long term testing of photo-stability and temperature stability
 - Further reduction of V_{π} possible (~30%)
- ★ Sub 1 V devices have been demonstrated and are under development at TACAN, Inc.
- ★ The integration of EO polymer guided wave optical devices with very high speed integrated electronics and with other guided wave polymer devices is the next step in the development.



Unclassified



Unclassified

PWI Two Mach-Zehnder Shifter Architecture



Photonic RF Phase Shifter Schematic

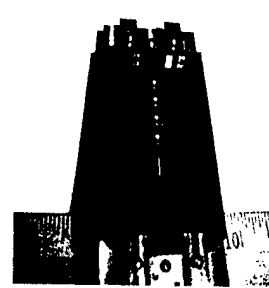
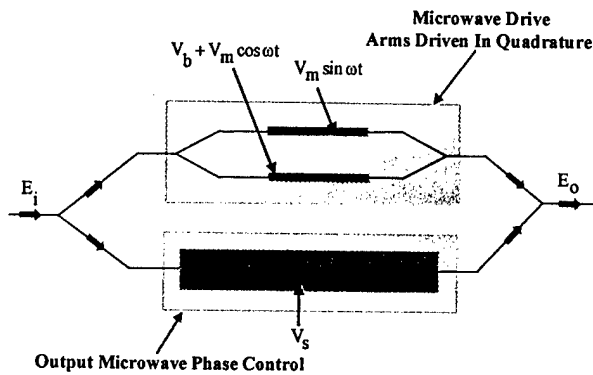

Chip containing 4 photonic RF phase shifters fabricated from CLD

- V_s DC or low frequency bias controlling output microwave phase
- V_b Bias generating an optical phase of $\pi/2$
- Microwave arms driven in quadrature

UNCLASSIFIED

Photonic Microwave phase shifters based upon these polymer devices have been developed and incorporated into a new generation of phased array antennas. The practical implementation of antenna arrays has been limited by the complexity of the feed structures and the active phase shifting elements. We have now demonstrated the insertion of this technology into a serial feed photonic configuration which is extremely low cost, lightweight, and has very low power consumption. Several versions of this device are also under development that will support this application up to 100 GHz.

In this first figure we show the basic version with two nested Mach Zehnder structures for our new phase shifter. The actual chip is shown in the photo on the left.

The output intensity at the modulation frequency for the 2 Mach-Zehnder architecture is given by

$$I_{\omega} \propto \frac{E^2}{16} (\sqrt{2}J_1(\sqrt{2}\Delta) + 4J_1(\Delta)\sin\phi)\sin\omega t - \frac{E^2}{16} (\sqrt{2}J_1(\sqrt{2}\Delta) + 4J_1(\Delta)\cos\phi)\cos\omega t$$

$$= A\cos(\omega t + \chi)$$

$$\Delta = \frac{\pi V_m}{V_{\pi}}$$

Modulation depth produced by microwave field

$$\phi = \frac{\pi V_s}{V_{\pi}}$$

Optical field phase shift due to applied quasi-DC field

- Intensity contains quadrature components of different amplitudes
- Changing amplitude of quadrature components by changing ϕ changes microwave phase χ

UNCLASSIFIED

The equations for the phase and amplitude of output of the two arms are relatively straight forward to derive. Unfortunately, the results are not extremely linear except for some very narrow regimes of operation. Using a network Analyzer we are able to measure these parameters extremely accurately.

Although the response is not quite linear we find that it would be extremely useful. The problem is, as we shall show with the amplitude as a function of phase.

Microwave phase as a function of V_s for the **2 Mach-Zehnder** architecture

$$\tan\chi = \frac{\sqrt{2}J_1(\sqrt{2}\Delta) + 4J_1(\Delta)\sin\phi}{\sqrt{2}J_1(\sqrt{2}\Delta) + 4J_1(\Delta)\cos\phi}$$

- Calculation parameters
 - a) Halfwave voltage 10.8 V
 - b) $V_m = 1.8$ V (small signal)
 - c) -2 V $< V_s < 20$ V
- 360° phase shift obtained in bias range
- $> 110^\circ$ linear regime observed
- Maximum deviation from linear approx. 73°
- Deviation from linearity caused by term containing $J_1(\sqrt{2}\Delta)$

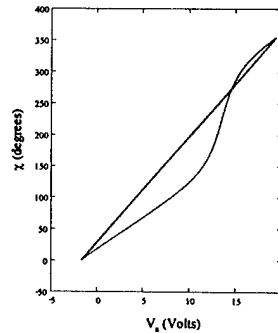

Red Curve - calculated microwave phase shift
Blue Curve - linear fit to end points

UNCLASSIFIED

Here we calculate the phase shift of our initial structure as a function of V . The deviation from being linear is shown in the curves on the left. In most cases a look up table could be used in this situation and the device would be useful.

The measured results fit the calculations very well over the range studied as demonstrated in the next figure.

Power as a function of V_s for the 2 Mach-Zehnder architecture

$$P_e = \frac{1}{2} \cdot R_1 \cdot R \cdot 2 \cdot P_o^2 \cdot \left\{ \left(\frac{\sqrt{2}J_1(\sqrt{2}\Delta) + 4J_1(\Delta)\sin\phi}{16} \right)^2 + \left(\frac{\sqrt{2}J_1(\sqrt{2}\Delta) + 4J_1(\Delta)\cos\phi}{16} \right)^2 \right\}$$

- P_e average electrical power produced by I_ω
- Calculation Parameters
 - a) $R_1 = 50\Omega$
 - b) $R = 1A/W$
 - c) $P_o = 1mW$
- Electrical power fluctuates 15 dB as χ varies with V_s
- Power fluctuation is also caused by the term containing $J_1(\sqrt{2}\Delta)$

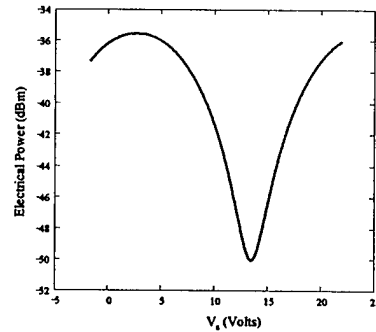

Calculated microwave power

UNCLASSIFIED

This figure shows the calculated electrical power from the optically detected output as a function of V . The electrical power fluctuates 15 dB as the phase angle is tuned.

Our measures confirmed this effect and we began to look at second generation devices for our phased array radar demonstration.

Linear Transfer Characteristics of the Phase shifter

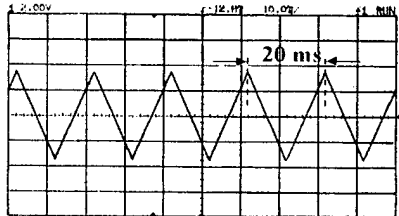

- Input to the DC electrode :-**
- 50 Hz triangular wave
 - Peak to peak voltage :-7.8 Volts

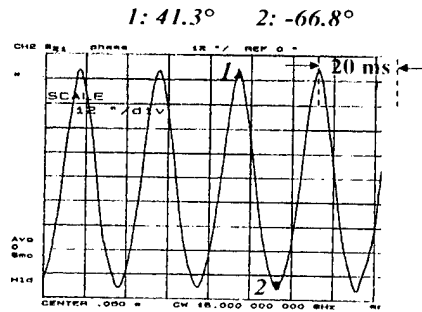

- Phase of the microwave signal at the output of the phase shifter:-**
- Near linear dependence with voltage on DC electrode
 - Deviation from nonlinearity due to high microwave driving power
 - Peak to peak phase change :-108.1°

UNCLASSIFIED

This is the actual output of our first polymer microwave optical phase shifters.

The results showed that these monolithic devices could do the job and actually be used to form an exciting new family of devices for phased array applications

- The microwave phase varies non-linearly with V_s as a result of the term containing $J_1(\sqrt{2}\Delta)$
- The microwave power fluctuates with V_s as a result of the term containing $J_1(\sqrt{2}\Delta)$
- This undesirable term arises from mixing of the two microwave drive arms
- Under the current 2 Mach-Zehnder architecture it is not possible to minimize the impact of this mixing term
- Goal – new photonic RF phase shifter with additional degree of freedom to reduce impact of undesirable mixing term

UNCLASSIFIED

Analysis shows that the origin of our power fluctuations is coming from mixing terms in the arms of our Mach Zehnder. Therefore we began to look for ways to cancel out the linear components.

The solution that we have come up with is shown in the next figure. It uses the flexibility inherent in our polymer modulators to add an addition level of Mach Zehnder.

PWI Three Mach-Zehnder Shifter Architecture

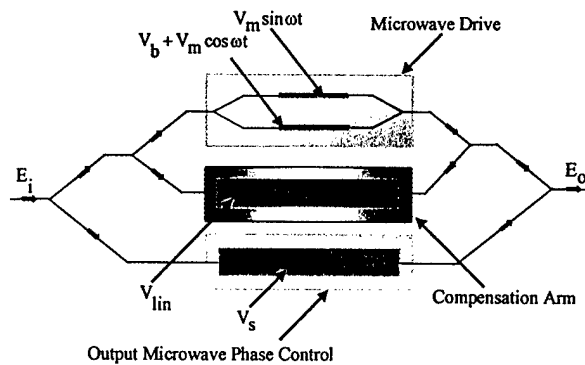

- Architecture consists of 3 nested Mach-Zehnders
- Added one degree of freedom
- V_{lin} DC bias on compensation arm chosen to minimize undesirable mixing term

UNCLASSIFIED

This device adds another degree of freedom to the phase shifter. It also represents an new class of complex devices fabricated using polymer technology.

The fabrication of this device will permit entirely new parallel configurations of radars using arrays of devices. However, later we will present a rather interesting serial application that just uses a single modulator device.

The output intensity at the modulation frequency for the **3 Mach-Zehnder** architecture is given by

$$I_{\omega} \propto \frac{E_{in}^2}{32} \left(\sqrt{2} J_1(\sqrt{2}\Delta) + 4J_1(\Delta) \sin\gamma + 8J_1(\Delta) \sin\phi \right) \sin\omega t - \frac{E_{in}^2}{32} \left(\sqrt{2} J_1(\sqrt{2}\Delta) + 4J_1(\Delta) \cos\gamma + 8J_1(\Delta) \cos\phi \right) \cos\omega t$$

$$= A \cos(\omega t + \chi)$$

$$\gamma = \frac{\pi V_{lin}}{V_{\pi}} = 22.5^{\circ} \quad \text{Compensating optical phase determined by the compensating bias}$$

- Intensity contains quadrature components of different amplitudes with one additional degree of freedom
- χ is controlled by changes in ϕ
- V_{in} is adjusted to minimize the impact of the term containing $J_1(\sqrt{2}\Delta)$

UNCLASSIFIED

Here are the equations for the operation of our new device. By changing the dc voltage on the center electrode it is possible to compensate for the mixing terms which make the first device difficult to use on a real system.

However before going further we must calculate the phase and see that it behaves at least as well as the previous device.

Microwave phase as a function of V_s for 3 Mach-Zehnder architecture

$$\tan \chi = \frac{\sqrt{2}J_1(\sqrt{2}\Delta) + 4J_1(\Delta)\sin\gamma + 8J_1(\Delta)\sin\phi}{\sqrt{2}J_1(\sqrt{2}\Delta) + 4J_1(\Delta)\cos\gamma + 8J_1(\Delta)\cos\phi}$$

$$= \frac{\sqrt{2}J_1(\sqrt{2}\Delta) - 2\sqrt{2}J_1(\Delta) + 8J_1(\Delta)\sin\phi}{\sqrt{2}J_1(\sqrt{2}\Delta) - 2\sqrt{2}J_1(\Delta) + 8J_1(\Delta)\cos\phi}$$

- Calculation assumptions
 - a) Halfwave voltage 10.8 V
 - b) $V_m = 1.8$ V (small signal)
 - c) $.3 \text{ V} < V_s < 22 \text{ V}$
 - d) $\gamma = 225^\circ$
- 360° phase shift obtained in bias range
- $> 140^\circ$ linear regime observed
- Maximum deviation from linear approx. 15°
- Linearity of χ vs. V_s improved significantly

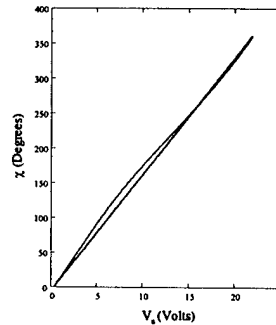

Red Curve - calculated microwave phase for shifter
Blue Curve - linear fit to end points

UNCLASSIFIED

The calculations show that this device is much more linear than our first set of nested Mach Zehnders. Most important is that it will work effectively over a much wider range of phase angles.

The optical losses through this device will only be slightly poorer than the first device. Now we must see if it does solve our amplitude problem.

Power as a function of V_s for the **3 Mach-Zehnder** architecture

$$P_e = \frac{1}{2} \cdot R_1 \cdot R^2 \cdot P_0^2 \cdot \left\{ \left(\frac{\sqrt{2}J_1(\sqrt{2}\Delta) + 4J_1(\Delta)\sin\gamma + 8J_1(\Delta)\sin\phi}{32} \right)^2 + \left(\frac{\sqrt{2}J_1(\sqrt{2}\Delta) + 4J_1(\Delta)\cos\gamma + 8J_1(\Delta)\cos\phi}{32} \right)^2 \right\}$$

- Calculation Parameters

- $R_1 = 50\Omega$
- $R = 1A/W$
- $P_0 = 1mW$

- Electrical power fluctuates 3 dB as χ varies with V_s

- Reduction of power fluctuation resulted from the reduction of the term containing $J_1(\sqrt{2}\Delta)$

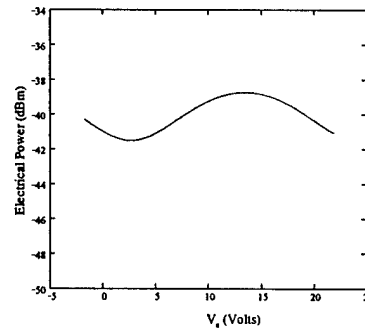

Calculated microwave power

UNCLASSIFIED

As we can see the power fluctuates less than 3 dB over this wide range of phase angles. The device will almost certainly solve our immediate needs for an optical - microwave phase shifter for phase array radars.

Since we have already tested these modulators up to over 100 GHz. this means that very high frequency systems are feasible with these phase shifters. Using these devices in arrays it will be relatively easy to make systems to do active beam forming and target tracking

- Case I. $\gamma = 225^\circ$
 - a) Compensation arm reduces undesirable mixing term
 - b) Maximum deviation of χ from linear approximation 15°
 - c) Power fluctuation 3 dB

- Case II. $\gamma = 45^\circ$
 - a) Compensation arm reinforces undesirable mixing term
 - b) Maximum deviation of χ from linear approximation 94°
 - c) Power fluctuation > 20 dB

- Compensation arm has a significant impact on the performance of the phase shifter

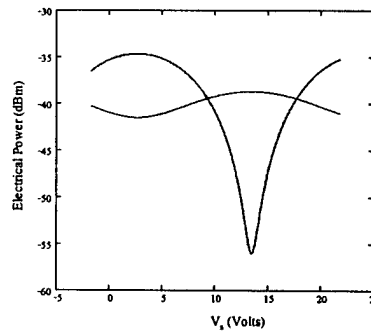

Calculated microwave power

Red Curve - $\gamma = 225^\circ$

Brown Curve - $\gamma = 45^\circ$

UNCLASSIFIED

The comparison shown in this figure shows the power of the engineering that can be done with polymer structures. We feel that these devices will also be extremely useful in a wide range of related microwave and RF links.

In the next figure we show how these devices can be incorporated into a very simple and powerful serial structure for phased array transmitters.

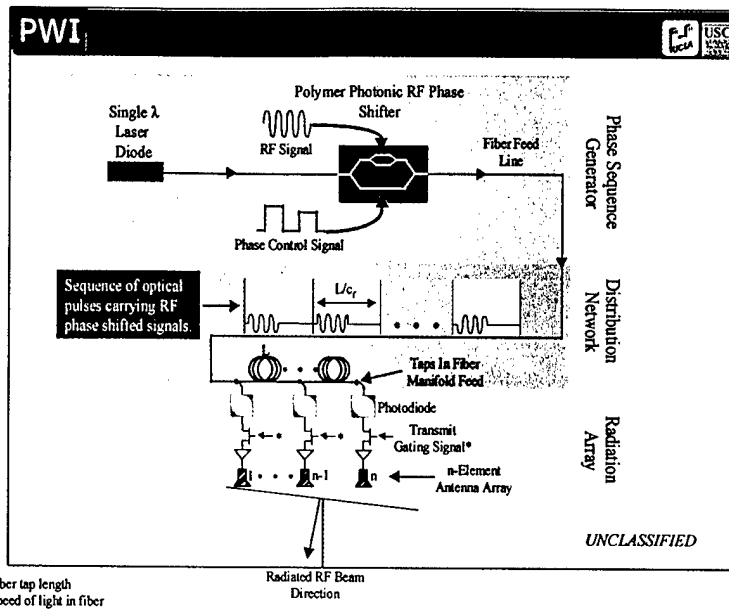

This figure shows the phase shifter, either of generation one or two, incorporated into a very simple, low cost, phased array radar transmitter. This system would be capable of operating up to 100 GHz - limited only by available optical detectors and rf millimeter wave amplifiers. It would be extremely flexible and even be capable of controlling multiple beams.

The use of these integrated, monolithic optical-microwave phase shifters can dramatically change the design of new phased array systems. We are just beginning to assemble X band systems with this basic configuration.