

JOURNAL

U.S. ARMY MEDICAL DEPARTMENT

October - December 1999

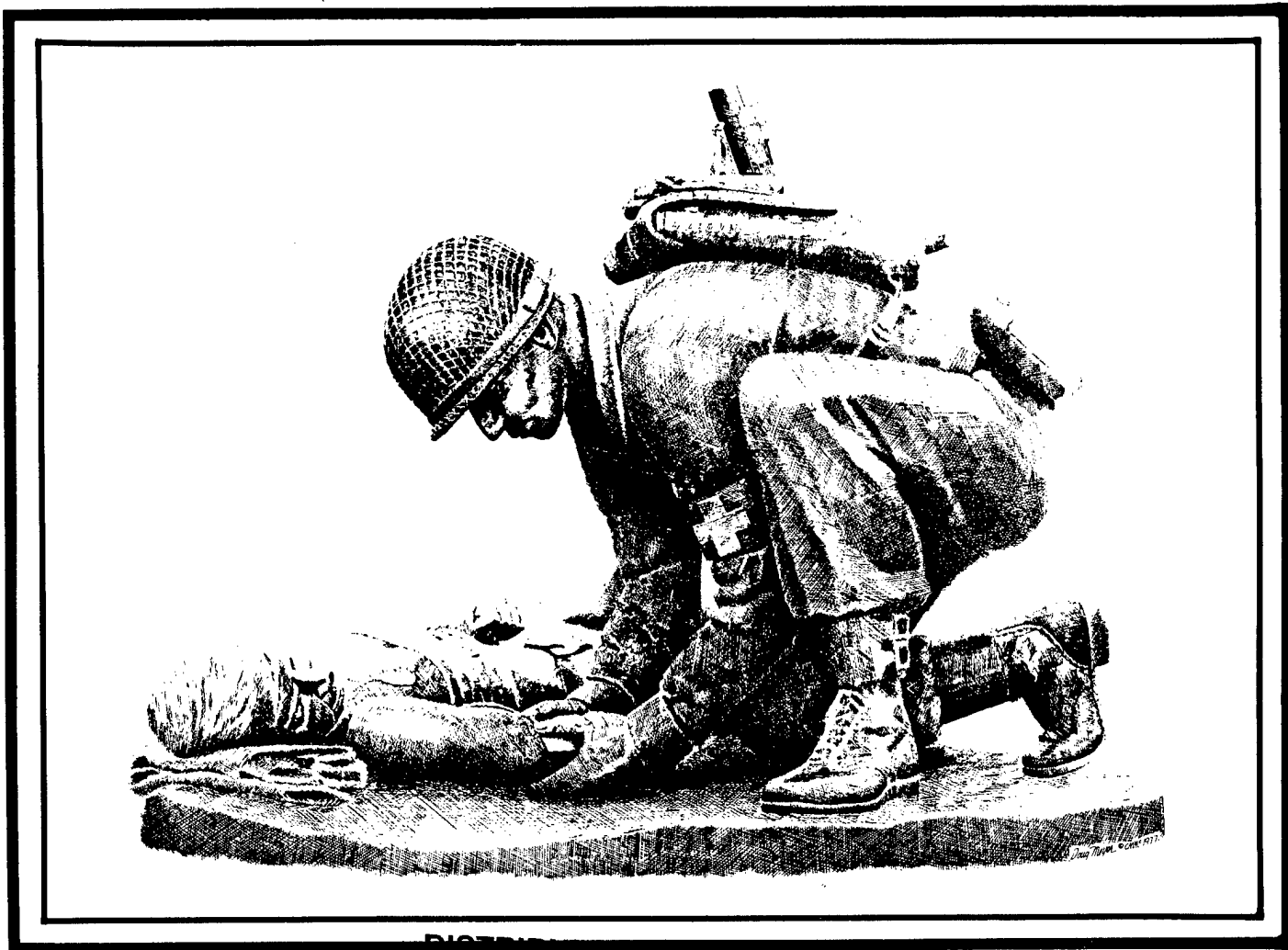

DISTRIBUTION STATEMENT A
Approved for Public Release
Distribution Unlimited

In this issue:

91W: Force XXI Combat Medic

Preparing for a Disaster

Case Studies in Aviation Medicine: Bosnian Deployment

20000823 041

J U.S. ARMY MEDICAL DEPARTMENT **JOURNAL**

A Professional Bulletin for the AMEDD Community

Internet address: <http://www.cs.amedd.army.mil>

ISSN: 1524-0436

LTG Ronald R. Blanck
Commander, U.S. Army Medical Command
The Army Surgeon General

MG James B. Peake
Commander, U.S. Army Medical Department
Center and School

- 1 Perspective**
MG James B. Peake
- 2 91 W: Force XXI Combat Medic**
MAJ Robert A. De Lorenzo, MC
- 7 Preparing for a Disaster**
LTC Domenic A. Sammarco, MS
- 12 Combat Stress Control Garrison Mission: A Model for the Future**
LTC Simon H. Pincus, MC / COL Michael R. Wymes, MC
- 17 Setting the (Dental) Record Straight**
COL Thomas D. Richardson, DC
- 20 Case Studies in Aviation Medicine: Bosnian Deployment**
CPT James R. Bean, SP
- 26 The Letterman System for Casualty Treatment and Evacuation**
MAJ Kyle D. Campbell, MS
- 29 Treating Rampant Caries: Winning the Battles, Losing the War**
CPT Jack F. Thompson III, DC / COL Robert D. Meyer, DC
- 33 Providing Echelon II CHS to a Digitized Fourth Brigade**
MAJ Barbara R. Holcomb, AN
- 36 AMEDD Dateline**
Wayne R. Austerman, PhD
- 40 1999 Author and Subject Indexes**

Senior Advisory Committee

COL Richard D. Shipley
Chairman

LTC Margaret A. Anderson
Department of Training Support

COL Paul L. Barrows
Department of Veterinary Science

COL Daniel F. Battafarano
Department of Medical Science

COL Richard E. Brown
Department of Clinical Support Services

COL Francis H. Chance
U.S. Army Reserve Advisor

COL Lynne M. Connelly
Department of Nursing Science

COL Edward O. Crandell
Department of Preventive Health Services

COL John W. Davis
Department of Dental Science

COL Loma H. Hassell
Center for Healthcare Education & Studies

COL Edward M. Knights
Department of Health Education & Training

Neta T. Lesjak
Department of Academic Support

COL James S. McGhee
U.S. Army School of Aviation Medicine

COL David L. Nolan
Assistant Commander for Force Integration

COL Milton R. Scholze
U.S. Army National Guard Advisor

COL Leonard J. Sly
Department of Healthcare Operations

COL Richard D. Shipley
Dean, Academy of Health Sciences

Neta T. Lesjak
Chief, Department of Academic Support

Bruce Nelson
Editor

Don Aldridge
Associate Editor

MAJ Robert De Lorenzo
Contributing Editor

Linda Nelson
Editorial Assistant / Desktop Publishing

By Order of the Secretary of the Army
ERIC K. SHINSEKI
General, United States Army
Chief of Staff
Official:

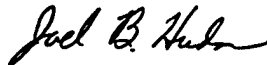

JOEL B. HUDSON
Administrative Assistant to the
Secretary of the Army
DISTRIBUTION: Special

9923901

The Army Medical Department Journal is prepared quarterly for The Army Surgeon General by the U.S. Army Medical Department Center & School, ATTN: MCCS-HSA, 2250 Stanley Road Ste 250, Fort Sam Houston, TX 78234-6150.

CORRESPONDENCE: Manuscripts, letters to the editor, photographs, official unit requests to receive copies, and unit address changes should be sent to the Journal at the above address. Telephone: (210) 221-6916/7326, DSN 471-6916/7326.

DISCLAIMER: The Journal presents clinical and nonclinical professional information designed to keep U.S. Army Medical Department personnel informed of healthcare, research, and combat and doctrine development information.

Views expressed are those of the author(s) and do not necessarily reflect official U.S. Army or U.S. Army Medical Department positions, nor does the content change or supersede information in other official Army publications. The Journal reserves the right to edit all material submitted for publication.

CONTENT: Content of this publication is not copyrighted. Material may be reprinted if credit is given to the author(s).

OFFICIAL DISTRIBUTION: This publication is targeted to U.S. Army Medical Department units and organizations and other members of the military medical community worldwide.

REPORT DOCUMENTATION PAGE

Form Approved
OMB No. 0704-0188

Public reporting burden for this collection of information is estimated to average 1 hour per response, including the time for reviewing instructions, searching existing data sources, gathering and maintaining the data needed, and completing and reviewing the collection of information. Send comments regarding this burden estimate or any other aspect of this collection of information, including suggestions for reducing this burden, to Washington Headquarters Services, Directorate for Information Operations and Reports, 1215 Jefferson Davis Highway, Suite 1204, Arlington, VA 22202-4302, and to the Office of Management and Budget, Paperwork Reduction Project (0704-0188), Washington, DC 20503.

1. AGENCY USE ONLY (Leave blank)		2. REPORT DATE October 1999	3. REPORT TYPE AND DATES COVERED Quarterly (Oct-Dec 1999)	
4. TITLE AND SUBTITLE U. S. Army Medical Department Journal			5. FUNDING NUMBERS	
6. AUTHOR(S) Bruce Nelson, Editor				
7. PERFORMING ORGANIZATION NAME(S) AND ADDRESS(ES) U.S. Army Medical Department Center and School Department of Academic Support AMEDD Journal Branch Fort Sam Houston, Texas 78234-6160			8. PERFORMING ORGANIZATION REPORT NUMBER	
9. SPONSORING / MONITORING AGENCY NAME(S) AND ADDRESS(ES) U.S. Army Medical Department Center and School Bldg. 2840 2250 Stanley Road Fort Sam Houston, Texas 78234-6160			10. SPONSORING / MONITORING AGENCY REPORT NUMBER	
11. SUPPLEMENTARY NOTES				
12a. DISTRIBUTION / AVAILABILITY STATEMENT Approved for public release: Distribution is unlimited.			12b. DISTRIBUTION CODE	
13. ABSTRACT (Maximum 200 words) Clinical and nonclinical professional information designed to keep U.S. Army Medical Department personnel informed of healthcare, research, and combat and doctrine development information.				
14. SUBJECT TERMS Medicine - Periodicals; Military Medicine - Periodicals			15. NUMBER OF PAGES 47	
			16. PRICE CODE	
17. SECURITY CLASSIFICATION OF REPORT N/A	18. SECURITY CLASSIFICATION OF THIS PAGE	19. SECURITY CLASSIFICATION OF ABSTRACT	20. LIMITATION OF ABSTRACT Unlimited	

Perspective

91W Healthcare Specialist

The combat medic forms the foundation of the Army's operational medical force. To keep the foundation solid, the Army Medical Department (AMEDD) has embarked on a major initiative to enhance the combat medic's capabilities. To symbolize the change, a new military occupational specialty (MOS) has been assigned to the medic: 91W. Within a few years, the current 91B Medical Specialist and 91C Practical Nurse MOSSs will merge into the new 91W designation.

The 91W initiative offers a glimpse into the future of the Army healthcare system. Flexible and versatile, the 91W will be at home in the foxhole, the outpatient clinic, and the hospital ward. Sustainment training will be frequent and focused on critical skills. Most importantly, the 91W will work as an integral member of the warfighting team.

Several innovations are part of the 91W initiative. Perhaps most apparent is the requirement for all 91Ws to achieve and maintain basic Emergency Medical Technician certification. This requirement introduces a clinical standard that will serve as a baseline and allow the 91W to achieve even greater skill proficiency. Another innovation is the goal of equipping even entry-level 91Ws with all the critical lifesaving skills needed on the battlefield. This ensures that even junior 91Ws assigned to forward elements of line units have all the requisite skills to initiate resuscitation.

This issue of the AMEDD Journal is dedicated to the combat medic of the future, the 91W Healthcare Specialist. Several articles in this issue focus on the 91W or the missions they accomplish.

- *91W: Force XXI Combat Medic.* Provides a concise overview of the 91W initiative. Many of the issues that sparked and propelled the program are outlined in the article. Commanders, leaders, and especially, soldier medics will appreciate this timely information.

- *Providing Echelon II CHS to a Digitized Fourth Brigade.* Shows a glimpse into the future combat health

support in Force XXI. Using the Prairie Warrior battle simulation exercise, the article explores some of the challenges of providing care on the battlefield.



Major General James B. Peake

- *Preparing for a Disaster.* Highlights the potential threat of chemical and biological warfare agents. This article is a potent reminder of the need for continual vigilance and preparedness for these and other weapons of mass destruction.

- *Case Studies in Aviation Medicine: Bosnian Deployment.* Describes the challenges of providing flight medicine in a deployed environment. The article uses a series of case studies to highlight strategies to meet the aviators' medical needs.

- *The Letterman System for Casualty Treatment and Evacuation.* Reviews Dr Jonathan Letterman's efforts to preserve life and ease suffering during the American Civil War. The effectiveness of the AMEDD's evacuation system is owed, in part, to Dr Letterman's revolutionary ideas.

Also in this issue are several others interesting and stimulating articles worth reviewing:

- *Combat Stress Control Garrison Mission: A Model for the Future.* Describes the dual mission of peacetime and operational mental healthcare and the challenge of achieving both. Several potential models to achieve the optimal approach are presented and discussed.

- *Setting the (Dental) Record Straight.* Provides a step-by-step approach to achieving excellence in dental records.

- *Treating Rampant Caries: Winning the Battles, Losing the War.* Highlights the importance of disease prevention, in this case, dental cavities, as well as treating the disease.

91W: Force XXI Combat Medic

MAJ Robert A. De Lorenzo, MC†

Introduction

Throughout the past decade, combat operations and military operations other than war have increased the challenges in providing quality healthcare to all soldiers. Future Force XXI operational characteristics of increased battle tempo, lengthened evacuation distances, and greater unit dispersion and maneuver call for a redesign of the medical infrastructure to bolster first responder capabilities. Because of these evolving challenges, the 91W Healthcare Specialist will emerge with the essential skill mix to support the Army on the future battlefield and beyond.

Future Battlefield

Force XXI is the U.S. Army plan to ensure battlefield superiority into the next millennium. Force

XXI envisions a dispersed, highly fluid battlefield, increased firepower and maneuverability, and improved situational awareness through digitized communication. The Army Medical Department (AMEDD), in turn, is adapting to the new concept by deploying a lighter and more mobile, yet highly capable medical force.

Force XXI envisions highly mobile forces dispersed about a large and highly fluid battlefield (Figure 1). Traditional front lines dissolve as friendly forces bypass pockets of enemy resistance and deep attacks by the enemy threaten friendly rear echelons. The static battles of yesterday are replaced by a dynamic and often chaotic warfight. To overcome the fog of war, improved communications and digital links improve situational awareness. In turn, this drives quicker reactions as U.S. forces capitalize on the element of surprise.

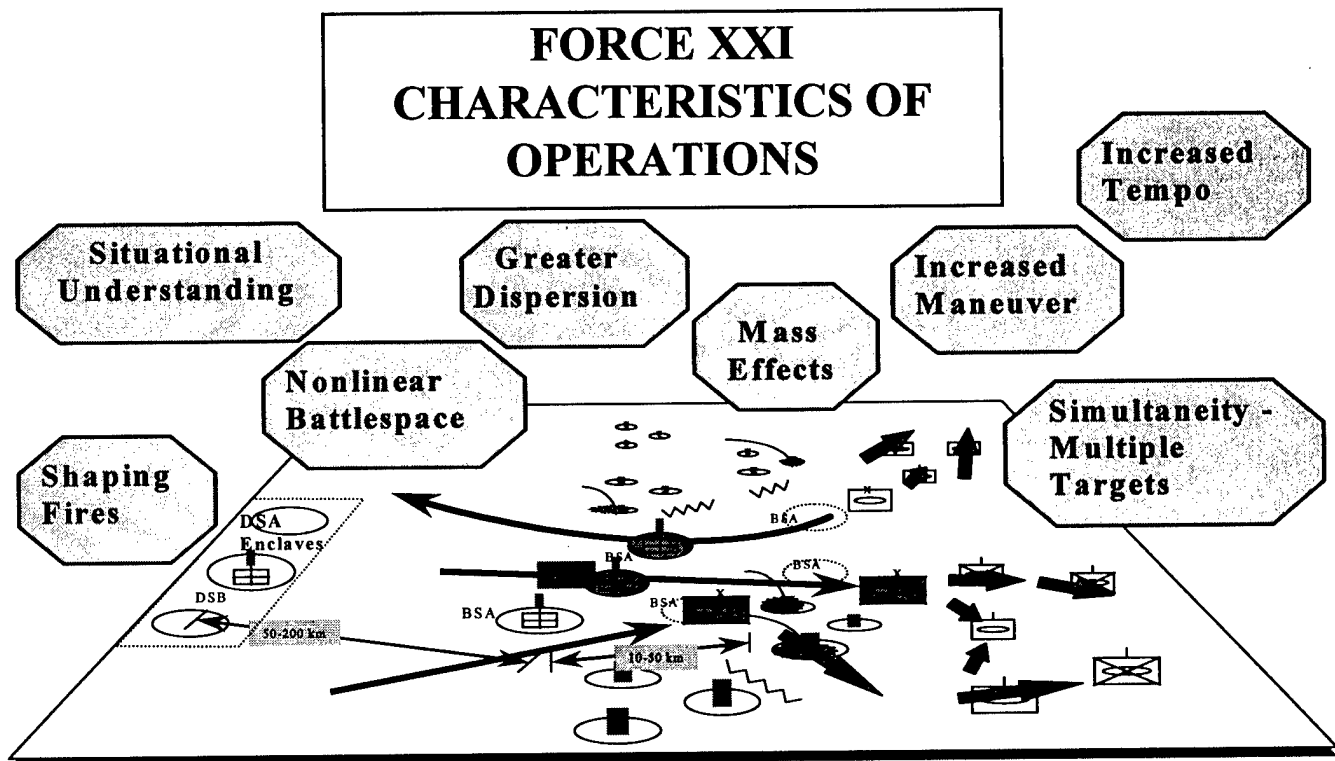

Fig 1. Nonlinear battlefield of the future.

From an AMEDD perspective, Force XXI presents several challenges. Most obvious is the need to assure competent emergency care in far-forward areas. Improved survival of combat casualties depends largely on early resuscitation. In most cases, it will be the combat medic who initiates this early care. A high degree of competency in a broad array of emergency care skills is a requirement for the Force XXI medic.

Another major challenge in providing Force XXI medical support derives from the expanded battlespace of divisional combat units. Battlespace roughly correlates to evacuation distances from point of injury or illness. In Figure 2, battlespace doubles from 100 to 200 km in Force XXI. Over rough terrain, 200 km can easily stretch into 8-hour transport times. Add this to the time it takes the casualty to reach the ambulance pick-up point and the challenges become apparent. The Force XXI medic must be capable of resuscitating and monitoring such casualties without the benefit of an on-site physician or physician assistance (PA).

on providing resuscitative and critical care, with more patients transferred out-of-theater to complete their hospital care in fixed facilities. The net result is a shift from ward and holding capacity to higher intensities of care. Personnel and equipment needs in Force XXI will reflect this shift.

Manpower Issues

The combat medic forms the core of the AMEDD mission. First response on the battlefield, initial care of disease and nonbattle injuries, and assisting in ambulatory and inpatient care are just a few of the important roles of the combat medic. There are greater numbers of combat medics in the AMEDD than any other category of healthcare provider, and medics are highly represented in the all-important far-forward areas of the battlefield. Therefore, it is not unexpected that the combat medic is viewed with increased attention by the AMEDD and line forces alike.

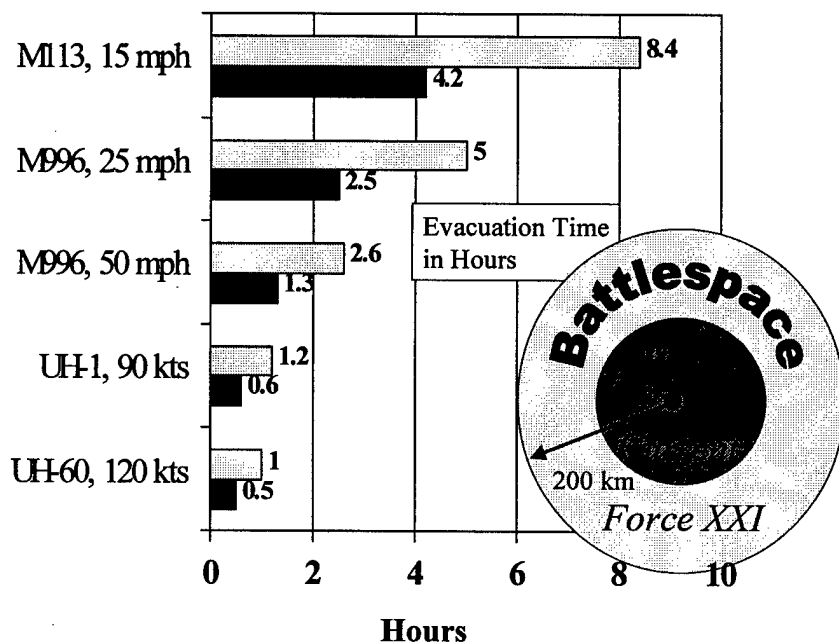

Fig 2. Battlespace dimensions and evacuation distances.

In keeping with the enhanced combat capability of the Force XXI division, the Army desired to increase far-forward medical capability. The existing entry-level military occupational specialty (MOS) 91B10, however, was felt to be insufficiently experienced and skilled to meet this increased demand. Instead, it was first proposed in the mid 1990s to place Sergeant/E-5 graduates of the AMEDD Basic Noncommissioned Officer Course (BNCOC) in the line platoon medic positions. (BNCOC currently trains combat medics in advanced lifesaving skills including intubation, needle decompression of pneumothorax, and cricothyrotomy.) The intent was to place school-trained

Lastly, future Army warfighting strategy calls for shorter evacuation policies and fewer in-theater hospital beds. Smaller, more mobile hospital units will concentrate

medical NCOs in the critical far-forward combat position. Similarly, company medics in heavy divisions were to be recorded at the Staff Sergeant/E-6 level.

The net result of this medical Force XXI redesign was the imminent conversion of hundreds of junior 91B10 positions into mid-level 91B30 positions. Because Army personnel policy limits the total number of soldiers by grade, the increase in line medical NCO positions had to be offset by a reduction elsewhere in the force. Since all the line medical NCO positions are restricted to males only (U.S. policy prohibits women from holding jobs in ground units that expect direct enemy contact), the remaining NCO slots offered limited opportunities for females to advance through the ranks. In effect, female 91Bs faced a "glass ceiling" at the rank of Sergeant/E-5.

In the late 1990s, the AMEDD Center and School launched a research study to examine the skills, training, and proficiency of the 91B10 combat medic. One arm of the Medic Training 2000 (MT2K) study measured the proficiency of recent school graduates. The data showed marked gaps in the skill levels of 91B10s and identified significant deficiencies in key lifesaving task performance.

The results of the MT2K study, coupled with the personnel changes already occurring under the division redesign, spurred the AMEDD to seek a combat medic to meet the challenges of Force XXI. Coincidentally, significant personnel issues in MOS 91C (Licensed Practical Nurse [LPN]) were also occurring. The AMEDD Medical Reengineering Initiative resulted in significant over-strength in the active component, as the medical footprint of the Army was rightsized. Stagnant promotions and a looming forced reclassification plagued active duty 91Cs. In the reserve components, recruiting, training, and retention challenges resulted in low end-strengths for reserve 91Cs. The combination of 91B and 91C issues caused the AMEDD leadership to define the Force XXI combat medic.

Force XXI Combat Medic

The 91W Healthcare Specialist has its roots in the *Future Medic* concept envisioned by the AMEDD Center and School's Directorate of Combat Development. In turn, the future medic drew upon successful models of military medicine including the Ranger and Special Forces medics. The future medic was envisioned as an enlisted medical soldier with strengths in combat casualty

care, force health protection, and limited ambulatory care. In concept and application, the future medic was an extension of the physician or PA, enabling these far-forward professionals to extend their care all the way to the point of injury or illness. The future medic was envisioned to be highly skilled in emergency care and capable of providing ongoing care to critical casualties on long evacuation legs. Finally, it was recognized that key medical skills are highly perishable, and so the future medic was expected to invest considerable time and energy maintaining and sustaining proficiency.

The 91W concept also draws on the strengths of other medical programs including the Navy hospital corpsman and Air Force medical technician. Civilian models such as emergency medical technician (EMT) training were incorporated as appropriate. Lastly, many of the fine components of the Army 91B and 91C programs were retained or adapted to suit the 91W Healthcare Specialist Program.

The 91W has four major areas of emphasis or core competencies (Table 1). The Force XXI medic is expected to provide competent far-forward care and evacuation off the battlefield, preserve the fighting strength through preventive medicine, and assist with the basic medical needs of the deployed soldier.

- | |
|--|
| <ul style="list-style-type: none">- Emergency Care- Evacuation- Force Health Protection- Limited Primary Care |
|--|

Table 1. Core Competencies of 91W Healthcare Specialist

Despite the far-forward battlefield emphasis, the 91W will be flexible enough to serve in the varied roles faced by the Army in the next millennium. Operations other than war, peacekeeping, peacemaking, and disaster relief are just a few of the scenarios for 91W training. The emerging threat of weapons of mass destruction is also

emphasized. Because of the Department of Defense emphasis on TRICARE services for beneficiaries, the 91W will also be capable and competent to provide appropriate care in fixed hospitals and clinics.

The guiding principles of 91W training are outlined in Table 2. They include a focus on far-forward care and integration into the battle force. The 91W will also be sufficiently trained in entry-level skills to serve in fixed and mobile hospitals in such areas as general medical and surgical wards, intermediate care wards, and ambulatory and emergency departments. A departure from the traditional 91B model is the training of junior-level 91Ws in all the critical emergency medical skills needed on the battlefield. This ensures that even the most far-forward warfighters have access to fully-capable medics. The 91W who is also LPN trained (new designation 91WM6) will be assigned to most traditional practical nursing positions including intensive care units, intermediate care wards, and medical detachments, surgical as well as regular 91W positions throughout the force.

- | |
|---|
| <ul style="list-style-type: none"> - Train to be integral member of warfighter team - Focus on far-forward care - Flexible enough to serve in variety of healthcare settings - Entry-level (91W10) has all the core medical skills - Ensure life-long learning and sustainment |
|---|

Table 2. Principles of 91W Training

The 91W training model (Figure 3) is built on three equally important components that include medical skills, soldier skills, and clinical experience and reinforcement. The glue that binds them together is skills verification. All 91Ws will be required to hold EMT-Basic (B) certification throughout their careers. In essence, EMT-B will form the foundation for the technical aspects of the MOS. The 91W is much more than EMT-B, however. The skills of

the 91W surpass that of an EMT-B, and actually resemble EMT-Intermediate (I). A new designator, EMT-Military, is being explored to emphasize the military-unique nature of the 91W skills.

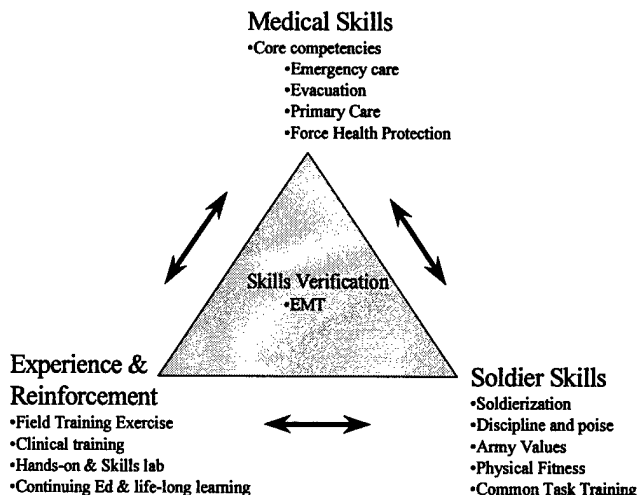

Fig 3. 91W Training model.

Transition

In time, all 91B and 91C soldiers (to include soldiers holding additional skill identifiers [ASIs]) will reclassify into the new 91W MOS. This is scheduled to begin on 1 Oct 2001. Several years from that date will be made available for soldiers to accomplish the MOS transition. Reserve component soldiers will be authorized additional years beyond active component timetables.

In general, soldiers holding an ASI of 91B or 91C will continue to keep this ASI once the soldier successfully transitions to the new 91W MOS. A new ASI, M6, will be authorized for soldiers who hold a valid, unrestricted LPN license. Thus, most 91Cs can expect to become 91WM6s once they successfully transition.

The MOS transition will require most soldiers to undergo additional training. This is to familiarize 91Bs and 91Cs with the new 91W tasks and ensure all 91Ws are properly enabled for success in their mission. Training will be made available in a number of formats to include unit training packages, distance learning (for example,

CD-ROMs), reserve component training, and resident format. Soldiers already trained and verified in some critical 91W skills will receive partial credit. To the fullest extent possible, recognized medical training programs will be recognized for partial credit. This may include EMT certification, LPN licensure, basic trauma life support (BTLS), pre-hospital trauma life support (PHTLS) courses, and advanced cardiac life support courses.

Selected 91B and 91C soldiers will be afforded the opportunity to transition directly into 91W in fiscal year 2002. Additional training for these soldiers will not be required, although a formal application process and documentation of credentials is anticipated. Because of their executive status, sergeants in the grades of E7 (promotable), E8, and E9 will fall into this special or "grandfathered" category.

The 91B and 91C soldiers of any grade who possess specialized training, certifications, and licensure will also be grandfathered. This includes soldiers possessing one of the following three combinations of valid credentials: (1) LPN plus National Registry EMT-B certification plus BTLS/PHTLS course completion, (2) National Registry EMT-I certification, and (3) National Registry EMT-Paramedic certification. This policy is in place to maximize the opportunity for highly skilled medical soldiers to qualify for immediate transition.

It is critical to recognize that the grandfathering policy is permissive in that it allows soldiers of certain rank or demonstrated skill to immediately qualify for transition without additional training. All other soldiers who do not "grandfather" will have the opportunity and time to train for and receive the 91W MOS.

Sustainment

It is well recognized that sustainment is critical to maintaining a ready force. Sustainment will be built into the 91W career model. Just as all soldiers must remain

proficient in physical fitness, common tasks, and weapons qualification, so to must 91Ws maintain certification in their core clinical skill area: EMT-B. A portion of unit MOS training will focus on continuing education requirements needed to maintain this certification. Sergeant's time, unit training, distance learning, weekend drills, and annual training can all be leveraged to complete the continuing education requirements. It is important to note that continuing education is not an additional training burden. Rather, it reflects a refocusing of existing sustainment training to support competency in critical emergency care skills. Preliminary analyses suggest that commanders and unit leaders will face little or no additional burden in terms of training time allotted to accomplish EMT recertification requirements.

Once every 2 years, 91W soldiers will be required to reverify their skills using the familiar go/no-go format. Skills verification testing will run very much like common task testing, except that combined Army and national emergency care standards will be used. This testing will ensure a competent medic force and provide commanders and leaders with an objective evaluation of individual soldier performance. This reverification of skills is in concert with national EMT-B recertification standards, and will enable soldiers to meet this requirement.

Conclusion

The 91W initiative represents a dramatic enhancement in the far-forward capability of the AMEDD. Improved medical skills, emphasis on force health protection and ambulatory care, and valuable periodic sustainment training all meet the needs of Army today and into the new millennium.

AUTHOR:

†Medical Corps. Major De Lorenzo is the Chief, 91W Branch, Department of Medical Science, Academy of Health Sciences, U.S. Army Medical Department Center and School, Fort Sam Houston, TX.

Preparing for a Disaster

LTC Domenic A. Sammarco, MS†

(Note: This article was originally published in the May 1999 issue of American Druggist [pp 41-45] and is reprinted with their permission.)

Three blasts disrupt the productive afternoon. Two short bursts followed by one long one from a 5-ton cargo truck concealed in camouflage is a loud and clear warning of imminent danger. Fear, that mixture of surprise and the unknown, washes over us. Our adversary – biochemical weaponry – is odorless, undetectable, and lethal. One weekend a month, I leave my pharmacy to provide a service of a different kind, this one to my country as an officer in the U.S. Army Reserves. In my capacity as Chief of Pharmacy Services in an FSP-1 (Forward Support Package) Combat Support Hospital, rapid deployment under potentially hazardous conditions is practiced regularly, including reviews of what injuries are likely to result and rehearsals of how to handle them (Figure 1).

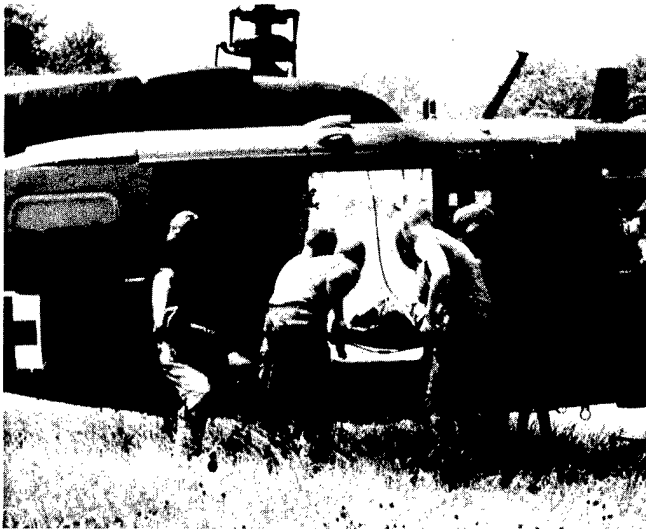

Fig 1.

Although pharmacists in the military are assured an active role in the case of warfare or a terrorist attack, civilian pharmacists may also be called upon in case of an emergency. In fact, the American Society of Health System

Pharmacists adopted a policy last year “to encourage health system pharmacists to establish emergency plans within their practice site and local community to address the public’s medication needs in the event of biological or chemical terrorist attack or other disasters.”

Toxic chemical and biological agents have actually been used for thousands of years. Poisoning of an enemy’s water supplies with rotting carcasses was a common practice in ancient times. In the 1300s, the Tatar catapulted corpses of plague victims into the besieged city of Kaffa (presently Feodosiya in Crimea). The epidemic that followed forced the defenders of Kaffa to surrender. History suggests that fleeing survivors of this siege caused the “Black Death,” the plague epidemic that swept Europe, causing the deaths of 25 million people during the 14th and 15th centuries. Can we state that America has not been exposed to chemical or biological warfare? No. Pizarro introduced smallpox among the indigenous people of South America in the 1500s. Later, the British introduced smallpox among Indians during the French and Indian War of 1754 to 1767.

On 27 October 1914, during World War I (WWI), the Germans used the lung irritant diaminodiphenylsulfate against the British, with no visible effects. Then, on 5 April 1915, the Germans used chlorine gas with mixed success. In May 1916, the Germans began using trichloromethyl chloroformate (diphosgene). French forces retaliated with hydrogen cyanide and cyanogen chloride. By July 1917, the Germans had improved their arsenal with the introduction of mustard gas, which injured parts of the body not protected by a gas mask. United States soldiers were first exposed to chemical agents 26 February 1918 when the Germans fired 150 to 250 phosgene and chloropicrin projectiles at

American forces in France.

The Germans used biological agents during WWI against horses and cattle on the western and eastern fronts and attempted to start a plague in St Petersburg, Russia. In 1918, the Germans delivered Ricin, a toxic agent made from the castor bean, via artillery shelling, which created the deadly Ricin dust cloud. Of the 26 million WWI casualties suffered by the British, French, Russians, Italians, Germans, Austro-Hungarians, and Americans, some 1 million were gas casualties. Of the total 272,000 U.S. casualties, more than 72,000 were gas-related. There were no casualties attributed to biological warfare in WWI.

In the last 20 years, the threat of chemical warfare has intensified after a lull of several decades. Chemical agents and some biological agents have been used in wars fought recently in Afghanistan and Iraq. In 1995, a Japanese terrorist group released sarin in a Tokyo subway. Related materials such as irritants and herbicides also lend themselves to modern warfare. As third world problems are increasingly transported to American soil, so does the likelihood that biological and chemical weapons will be used here. In fact, an Anthrax bombing attempt of a Brooklyn, NY, subway was thwarted by authorities in 1998.

Chemical warfare has been called the “poor man’s nuclear bomb” because of its horror-producing effects and ease of production. Indicators of the presence of chemical agents include tears, difficulty breathing, choking, itching, coughing, and dizziness. Surrounding conditions indicating the presence of chemical agents – dead animals, sick people, people or animals displaying abnormal behavior – can also provide valuable clues. The sense of smell may be the most valuable of the five senses, though many chemical agents are odorless. The smell of newly cut grass or hay may indicate the presence of choking agents. A smell of almonds may indicate blood agents. Irritation of the nose, eyes, or the skin is an urgent warning to protect your body from chemical agents. Additionally, a strange taste in food or water is a warning that these have been contaminated.

All countries have sites of hazardous chemical production or storage facilities. Most of these chemicals are used for peaceful purposes. Examples include agricultural (insecticides, herbicides, and fertilizers); industrial (chemicals

used in manufacturing); and production and research (chemicals and biological agents used in research or production facilities). Damage or destruction of a facility or storage site can create the unexpected release of chemical products. Biological agents fall into two broad categories: pathogens (also called germs) and toxins (naturally produced poisons). Being prepared is the best survival technique.

Pathogens are living microorganisms such as bacteria or viruses that can cause lethal or incapacitating diseases. The most common area of bodily entry is through the lungs. Only a few germs are needed to start a lung infection. Because germs are so small and weigh so little, wind can spread them over great distances. Germs do not affect the body immediately. They multiply inside the body until they overcome the body’s defenses – a process called incubation. Incubation periods vary from several hours to several months. Most germs need to live within another living organism (host) to survive and grow. Weather conditions such as wind, rain, and sunlight rapidly kill germs. Germs can also enter the body through a break in the skin or through the digestive tract (Figure 2).



Fig 2.

Toxins are substances produced naturally by plants, animals, or pathogens. The toxins and not the pathogens are what cause harm. Botulin, which produces botulism, is an example. Modern science has allowed large-scale production of these toxins. Toxins enter the body in the same manner as germs, though some toxins can penetrate unbroken skin. Toxins may produce effects similar to those of chemical

agents. Symptoms appear almost immediately, since there is no incubation period as in pathogens. Many toxins are extremely lethal, even in very small doses. Symptoms may range from dizziness and mental confusion to convulsions and death. Toxin victims may not, however, respond to first aid measures that are effective against chemical agents.

The "hot zone" is ground zero in the event of an attack. This hot zone can expand by thousands of feet per second. In a chemical or biological attack, the hot zone and all the people within this area may be contaminated. Usually, emergency medical responders will not be as well equipped or mentally prepared to enter such an area as military medical personnel. Scene awareness is critical whether you are a seasoned medic or highly trained civilian. Biological agents cannot be detected by any of the five physical senses. Often, the first sign of a biological agent will be seeing victims' symptoms indicating exposure to the agent (Figure 3).



Fig 3.

The best chance of detecting biological agents before they can affect you is to recognize their means of delivery:

- *Bursting-type munitions* are bombs or projectiles whose burst causes very little damage but produces a small cloud of liquid or powder in the immediate impact area. This cloud will disperse eventually, depending on terrain and weather conditions.

- *Spray tanks or generators* are aircraft or vehicle

spray tanks or ground-level aerosol generators that produce an aerosol cloud of biological agents.

- *Vectors* are typically insects such as mosquitoes, flies, lice, and ticks used to deliver pathogens. Large infestations of such insects may indicate the use of biological agents. Another sign of a possible biological attack is the presence of unusual substances on the ground or on vegetation, or sick looking plants, crops, or animals.

The development of chemical and biological casualty care starts with correct identification of the agent employed. Part of the military's medical training is to examine the characteristics and pathophysiology of chemical and biological agents to understand and develop the most effective medical countermeasures for each threat.

Medical personnel must fight a two-headed dragon. In the event of an attack, they must be able to protect themselves from exposure while also caring for contaminated patients. Patient decontamination stations must be prepositioned in areas outside the hospital proper so as to reduce the likelihood of cross-contamination. This feat is not easily accomplished in any environment, especially while wearing protective clothing.

Protective clothing comes in a variety of types, depending on the protection required to perform a specific mission. Most troops use permeable protective clothing, which allows for air and moisture to pass through the fabric without hindering the clothing's chemical protection capabilities. These permeable protective overgarments are called Battle Dress Overgarments (BDO). The BDOs are manufactured in two layers: a tightly woven outerlayer and a charcoal impregnated inner layer to absorb agent liquid or vapor. These layers protect the wearer from all chemical agent vapors, liquid droplets, biological agents, toxins, and offer limited protection against radioactive particles. The BDO protects the wearer for up to 24 hours after exposure. As with all protective overgarments, though, a high degree of chemical protection results in a negative impact on an individual's dexterity and performance. Patient care activities are greatly hindered by any biological and chemical protective clothing.

Mission Oriented Protective Posture (MOPP) Level

4 (Figure 4) provides the highest degree of chemical protection, but it also has the most negative impact in an individual's performance. The soldier will completely encapsulate themselves by closing their overgarments, rolling down and adjusting the mask hood, and putting on the nuclear biological chemical (NBC) rubber gloves with cotton liners.



Fig 4.

The Fox XM93 NBC Reconnaissance System is a fully integrated NBC reconnaissance system. This six-wheeled amphibious armored cargo and tactical transport vehicle is powered by a V8 diesel engine (320 horsepower). At combat load, this 18.7-ton vehicle can cruise at 65 mph with a cruising range of 500 miles. Your Porsche may go a bit faster but don't get in this bad boy's way. It is equipped with a 40 mm smoke grenade launcher and a M240E1 7.62-mm machine gun. Even the Los Angeles smog can't stop the Fox because it is equipped with a collective protection system, which keeps the air in the crew's working area free from outside contamination.

The integrated NBC Defense/Detection system has four key components:

- Mobile mass spectrometer which monitors and identifies all known chemical agents.
- Radiac equipment for radiation detection, identification, and computation.
- Vehicle orientation system consisting of chemical

and radiological instruments and capable of pinpoint map location.

- NBC marking equipment using an air lock system which allows deployment of NBC marking buoys.

Current U.S. military doctrine states that we will not use chemical weapons in a first strike capacity. Only the President may order chemical weapons retaliation. The U.S. has also said it will not use toxins or other biological agents under any circumstances. All research on biological agents is being limited to defensive measures.

Some 70% of all American military medical assets are allocated to the operation of the Reserve Forces, which consist of separate units under the command of the U.S. Army, Navy, and Air Force. The management of chemical and biological casualties is an essential part of reservists' training.

As in all medical applications, pharmacy services are a vital component in casualty care. From vaccines, drug therapy, chemotherapeutic regimens to chemoprophylactic protocols, pharmacists' knowledge and ability to deliver such care are key to achieving positive medical outcomes.

You can reduce your own susceptibility to biological agents by maintaining current immunizations, avoiding contaminated areas, and controlling rodents and pests. Sources of food and water should be noted safe or properly decontaminated.

Areas of planning include:

- Coordinate with civilian and military emergency response teams from local, state, or federal facilities.
- Capability to identify what chemical or biological material is present, type of contamination hazard, and how far the contamination hazard will extend.
- Determination as to whether standard chemical defense equipment (for example, protective mask, boots, suit, gloves) will offer sufficient protection against a specific hazard.

Planning and perpetual vigilance is the best protection against any biological or chemical attack.

Dedication

This article is dedicated to the Army medic, the first line of medical defense in wartime. Although in ancient times medics carried the caduceus into battle to signify the neutral, humanitarian nature of their tasks, they

have never been immune to the perils of war. To save the lives of others, they have made the highest sacrifices. Their dedication to assisting wounded soliders forms the foundation of military medical care.

AUTHOR:

†Medical Service Corps. Lieutenant Colonel Sammarco is the Chief, Pharmacy Services, 405th Combat Support Hospital, West Hartford, CN.

Pathogens	Incubation Period	Mortality Rate	Vaccine Available
BACTERIA:			
Anthrax	1-5 Days	High	Yes
Tularemia	1-10 Days	Low	Yes
Plague	2-5 Days	High	Yes
Cholera	1-5 Days	High	Yes
Typhoid Fever	7-21 Days	Moderate	Yes
VIRUSES:			
Japanese B Encephal	5-15 Days	Moderate	Yes
Yellow Fever	4-5 Days	Moderate	Yes
Dengue Fever	5-6 Days	Moderate	No
Smallpox	11-13 Days	High	Yes
Hemorrhagic Fever	11-13 Days	High	No
Ebola Fever	2-6 Days	High	No

Biological Agents

Combat Stress Control Garrison Mission: A Model for the Future

LTC Simon H. Pincus, MC†
COL Michael R. Wymes, MC††

There has been considerable controversy and outright frustration regarding how to conduct the Combat Stress Control (CSC) mission in garrison with the activation of the six Active Component CSC Detachments beginning in 1993. This article will review the strengths and weaknesses of three basic training models: the Fixed Site Plan, the Farmed-Out Plan, and the Deployed Plan. Evaluation criteria are selected to include provision for deployment readiness, training to doctrine, clinical competence, and access to care. A comprehensive analysis of each model is undertaken which identifies the Deployed Plan as the best course of action. Findings result in valuable insight for the future of CSC Detachments in the garrison setting.

Introduction

Beginning in 1993, six Active Component CSC Detachments were activated at Fort Bragg, Fort Campbell, Fort Carson, Fort Hood, Fort Lewis, and Wiesbaden, Germany. Upon activation, the initial task was to aggressively fill modification table of organization and equipment personnel and supply requirements. Soon thereafter, CSC Commanders were faced with the need to develop a meaningful garrison mission. Almost immediately, each of these detachments began operating outpatient mental health clinics based on previous experience with the medical model of patient care delivery. However, they met several obstacles. Specifically, units found themselves torn between providing direct patient care and preparing for their deployment mission. There was intense pressure placed by the local medical treatment facility (MTF) to provide mental health services to soldiers in a time of diminishing resources. In addition, the CSC Detachments relied on their parent MTF for their professional credentials to practice. As a result, deployment readiness was significantly hindered. This led to great disapproval by the immediate raters of the CSC Detachment Commanders. Most CSC Detachments have since abandoned their primary patient care role.

Background

The CSC mission is to prevent and restore soldier

stress casualties resulting from combat, peace enforcement, and other contingency operations.¹ Designated as the highest authorized level of organization for filling personnel and equipment needs, CSC Detachments must be ready to deploy on very short notice. Typically, this means that the time from alert to "wheels up" is no longer than 7 days. In very high demand, CSC Detachments have deployed to Somalia, Cuba, Haiti, and Bosnia.^{2,3}

The Challenge

The CSC Detachments must maintain and enhance their readiness to project CSC to soldiers in a deployment. The challenge facing Detachment Commanders is how to conduct the most realistic CSC training in garrison to prepare their units for this deployment mission. In addition, CSC Commanders are pressured to provide mental health services at their home installation with a focus on improving access to care.

Unit Organization

The CSC Detachments have the capability of fielding three Prevention Teams and one Restoration Unit.¹ Personnel strength consists of nine officers and 14 mental health specialists for a total complement of 23 soldiers. The nine officers include three psychiatrists, one psychologist, three social workers, one psychiatric nurse

practitioner, and an occupational therapist. Two of these nine officers – psychiatrist and social worker – are “Professional Fillers” assigned to the MTF. As such, they are not available to participate in the CSC garrison mission.

The Prevention Teams are comprised of two officers and two mental health specialists. Each team is capable of projecting CSC services far forward to soldiers on the battlefield. These services include command consultations, critical event debriefings, unit surveys, triage of suicidal and homicidal emergencies, brief counseling and treatment, stress management classes, and training in suicide prevention.⁴ By working in conjunction with Forward Support Medical Companies, Prevention Teams can also provide limited “holding” of soldier stress casualties. If the crisis does not resolve in the first 48 hours, the stressed soldier is evacuated to the Restoration Unit.

The Restoration Unit’s principle task is to restore soldier stress casualties and return them to full duty. Three Mental Health Officers and eight enlisted personnel are charged with providing a safe holding environment for 3 to 7 days. If there is no Neuropsychiatric Unit available, the Restoration Unit must also be prepared to treat traditional psychiatric inpatients.^{3,5}

Dual Taskings

Soldiers in the CSC Detachments are all dual-tasked, not only with their primary clinical specialty, but also a required military responsibility.¹ These military tasks include Commander, Executive Officer, Detachment Sergeant, Training, Supply, Motor Sergeant, Unit Movement Officer, Safety Officer, Hazmat (Hazardous Materials), Nuclear, Biological and Chemical (NBC), Communications, Preventive Medicine, Reenlistment, and Equal Opportunity. In addition, each team – three Prevention and one Restoration – requires a Team Leader and Noncommissioned Officer in Charge. As a result, integrating and balancing clinical and military responsibilities prove to be significant challenges.

Assumptions

Conducting a garrison mission that mirrors actual

services delivered during deployment – prevention and restoration – maximizes deployment readiness and training to doctrine (“clinical readiness”). A second assumption is that deployment readiness and clinical readiness must be distinct and separate activities defined by clear boundaries. Specifically, CSC Detachments must “fence” time for clinical work in order to provide reliable care to soldiers and to foster credibility with their chains of command. However, the time fenced for “clinical” readiness must not be so great as to compromise the unit’s overall readiness to deploy.

Evaluation Criteria

It is important to develop evaluation criteria, which address these challenges and assumptions as well as taking into account the unit’s organization and requirement for dual-taskings. Clearly, the model for the CSC garrison mission must maintain a high state of deployment readiness and must provide for training to CSC doctrine. The model should provide for the maintenance of primary clinical skills such as psychiatry, psychology, social work, occupational therapy, nursing, and behavioral science. It is also highly desirable that this model provide for continuity, credibility, and timely access to quality care by means of “fenced” time for successful execution of the clinical mission. In sum, the principal evaluation criteria are deployment readiness, training to doctrine, clinical competence, and access to care.

Weighting of Criteria

In order to choose the best course of action or “model” for the CSC garrison mission, it is necessary to assign a value of relative importance to each of the four evaluation criteria (Table 1). The CSC Detachments must be ready to deploy and fully trained to perform their prevention and restoration missions. Given this, deployment readiness and training to doctrine are judged to be equally important objectives. While also very important, maintaining clinical competency is deemed less essential to accomplishing the deployment mission. Last, providing mental healthcare for soldiers on the installation is a laudable goal. However, creating more accessible care in garrison is considered the least important objective in achieving a successful deployment.

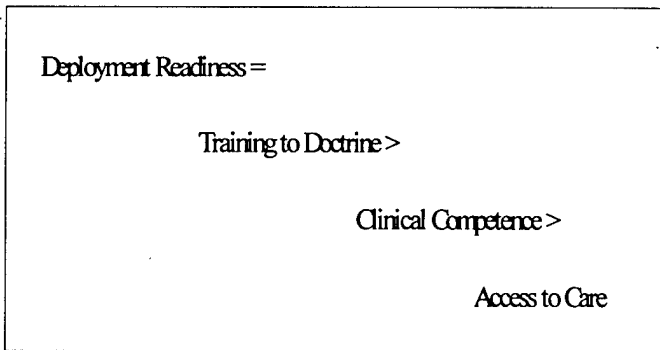

Table 1. Weighting of Criteria

Three Models

There are three basic models for the CSC garrison mission: the Fixed Site Plan, the Farmed-Out Plan, and the Deployed Plan. Each of these is analyzed and ranked with respect to the four evaluation criteria (Table 2).

FIXED SITE	Competence > Access > Readiness = Doctrine
FARMED-OUT	Competence > Readiness = Access > Doctrine
DEPLOYED	Readiness = Doctrine > Access > Competence

Table 2. Analysis of Models

The Fixed Site Plan

The Fixed Site Plan consists of a freestanding clinic which provides outpatient mental healthcare to soldiers. As stated earlier, this model was initially chosen by most of the CSC Detachments shortly after their activation. Its advantages include maintenance of clinical competence and more time spent on individual patient care; however, the Fixed Site Plan is problematic because readiness to deploy is not given the highest priority. Rather, providing care to soldiers in acute crisis – homicidal or suicidal – takes precedence. In addition, soldiers seeking mental healthcare require a series of follow-up sessions, which further detracts from the CSCs deployment mission. Last, and probably most significant, the Fixed Site Plan does

not provide for training to doctrine with care delivered proximate to the Combat Brigades. It is not surprising that this model was eventually abandoned by most of the CSC Detachments.

The Farmed-Out Plan

The Farmed-Out Plan refers to having individual personnel or teams from the CSC Detachment work for separate and distinct periods of time in their local MTF. This is analogous to medical proficiency training where the focus is to maintain primary clinical skills and provide direct care to soldiers. For individual soldiers, this training is usually over a 90-day period. For teams, this could be limited to a 1-month period or a given day of the week. The advantage of this arrangement is that it allows the CSC leadership to focus on issues of deployment, while the MTF focuses on maintaining clinical competence. The main disadvantages are that it does not provide experience in far forward preventive or restorative care proximate to soldiers, nor does it contribute directly to deployment readiness.

The Deployed Plan

The two major objectives of the Deployed Plan are to project the Prevention Teams forward to the Combat Brigades and to set up the Restoration Unit on a regular basis to provide stress management training for soldiers.⁶ A significant advantage of the Deployed Plan is that it optimizes deployment readiness by focusing on essential collective and individual soldier tasks. These essential tasks include weapons' qualification; NBC training; individual medical readiness and immunizations; preventive maintenance; checks and services of all equipment; vehicle load plans; convoy operations; setting up tents and generators; establishing radio communication with SINCGARS; training with night vision goggles, and global positioning systems; family support groups; force protection; and responding to terrorism. Another important advantage of this model is that it optimizes training to doctrine by delivering CSC services with proximity, immediacy, expectancy, and simplicity.^{7,8} Last, the Deployed Plan provides for access to preventive care proximate to the Combat Brigades, and restorative care to

subclinically stressed soldiers. The main disadvantage is less time spent for individual patient care.

Results

The Deployed Plan is the best model for the CSC garrison mission. This determination is accomplished by means of a decision matrix (Table 3). Scores are obtained by multiplying the evaluation criteria weights by their relative ranks in a given model. The total is then added up; the smallest total score represents the optimal model. The Deployed Plan is the best model because it maximizes deployment readiness and training to doctrine. It also provides for access to care and allows for maintenance of clinical competency.

WEIGHTS	3	3	2	1	
	DEPLOYMENT READINESS	TRAINING TO DOCTRINE	CLINICAL COMPETENCE	ACCESS TO CARE	TOTALS
FIXED SITE	3	3	1	2	22
FARMED-OUT	2	3	1	2	19
DEPLOYED	1	1	3	2	14*

* THE SMALLEST VALUE REPRESENTS OPTIMAL MODEL

Table 3. Decision Matrix

Implementation

The first objective of the Deployed Plan is achieved by "deploying" a Prevention Team with each Brigade-level field training exercise.⁶ Prime opportunities include rotations at the National Training Center in Fort Irwin, CA, the Joint Readiness Training Center at Fort Polk, LA, the Jungle Operations Training Center at Fort Sherman, Panama, and at Hohenfels Training Area in Germany. As a result, these teams are then well positioned to provide feedback on soldier stressors and potential interventions. This can be accomplished by direct feedback from command-directed soldier mental health evaluations or, on a more systemic level, during Brigade Command and Staff meetings. In garrison, the Prevention Teams can provide limited neuropsychiatric

triage at the troop medical clinic, chaplain's office, or other area set aside for this purpose at their assigned Brigade. The CSC personnel can maintain their basic clinical skills by conducting one-time soldier mental health evaluations. These evaluations include Command-directed referrals and "chapter" mental status exams for soldiers pending administrative separation. Experience indicates that up to 2 half days per week can be devoted to these activities without compromising deployment readiness. Significantly, CSC Detachments are frequently on alert status and unable to provide long-term treatment. As a result, the more complicated psychiatric cases need referral for follow-up care at the local MTF. Another important function is to actively train supported units – leaders, chaplains, and medical personnel – to recognize, manage, and reduce battle fatigue and other stress-related casualties.^{4,9} Last, the most significant contribution of the Prevention Teams in this model is responding to serious soldier accidents and fatalities. By conducting a Critical Event Debriefing in the first 48-72 hours, soldier stress casualties can be minimized or prevented, unit cohesion enhanced, and mission effectiveness supported.^{3,10-12}

The second objective of the Deployed Plan is to provide stress management training for soldiers. This format essentially provides for a 3- to 5-day psychoeducational program whose main goal is to enhance soldier coping-skills both on the job and at home. The concept is a program that mirrors the type and length of treatment provided during deployment. The ideal target population is the soldier who reports significant stress, but is not yet a stress casualty requiring intensive psychiatric care. An effective stress intervention can also prevent or minimize soldier misconduct behaviors such as absent without leave, substance abuse, and a host of other disciplinary problems.^{4,13} Conducting this program in a field setting provides more realistic training. In addition, successful marketing of CSC services is accomplished by locating the field site close to the parent MTF. The goal is to maintain, and sustain, readiness to deploy a fully functional Restoration Unit. Cross-training these skills with the Prevention Team members is strongly encouraged. This permits increased flexibility of personnel assignments during lengthy deployments.³

Discussion

The CSC Detachments serve as true combat-multipliers by keeping the force "mentally fit" to fight and win on the battlefield.³ This role is now expanded through prevention and restoration of soldier stress casualties in the garrison setting. The CSC Detachments have already won considerable praise and confidence from the line units they support. In particular, credibility is established by deploying Prevention Teams downrange with Brigade-sized elements and by their rapid response to serious soldier injury or fatality. However, the actual impact of these efforts is difficult to measure. The traditional measure of service by "outpatient visits" does not hold. Nor is it easy to quantify the number of stress casualties prevented through effective consultation to Commanders. Future outcome measures need to be developed; in the meantime, CSC Detachments will continue to deploy to every major military contingency operation.

Summary

This comprehensive analysis of three training models – the Fixed Site Plan, the Farmed-Out Plan, and the Deployed Plan – provides a rational approach for CSC Detachments to develop a meaningful garrison mission. In this regard, the authors have sought to reduce the controversy that surrounds the utilization of CSC resources in garrison and promote greater understanding of the CSC deployment mission. Although the Deployed Plan is the ideal, the authors recognize that unique circumstances may require a "tailor-made" CSC garrison mission that uses the best elements of each model. The bottom line is units that are ready to deploy on very short notice and well trained to perform their doctrinal mission.

References

1. U.S. Department of the Army. FM 8-51, Combat Stress Control in a Theater of Operations. Washington, DC; September 29, 1994.

2. Hall DP. Stress, Suicide, and Military Service during Operation Uphold Democracy. *Mil Med.* 1996;161(3):159-162.
3. Pincus SH, Benedek DM. Operational Stress Control in the Former Yugoslavia: A Joint Endeavor. *Mil Med.* 1998;163:358-362.
4. U.S. Department of the Army. FM 22-51, Leaders' Manual for Combat Stress Control. Washington, DC; September 29, 1994.
5. Gaylord KM. Psychiatric Nursing: A Critical Role in Deployment. *U.S. AMEDD J.* March-April 1998;pp 28-31.
6. Neff R. Utilization of CSC Detachments. *Mil Med.* 1998;163:191-192.
7. Artiss KL. Human behavior under stress: From combat to social psychiatry. *Mil Med.* 1963;128(10):1011-1015.
8. Soloman Z, Benbenishty R. The role of proximity, immediacy and expectancy in the frontline treatment of combat stress reaction among Israelis in the Lebanon War. *Am J Psychiatry.* 1986; 143(5): 613-617.
9. Noy S. Combat Stress Reactions in Handbook of Military Psychology. New York: John Wiley and Sons; 1991:pp 507-530.
10. Koshes RJ, Young SA, Stokes JW. Debriefing following Combat in Textbook of Military Medicine, Part I: War Psychiatry. Washington DC: Borden Institute; 1995:pp271-290.
11. U.S. Department of the Army: Debriefing's Guide to Critical Event Debriefing, Fort Sam Houston, TX: Combat Stress Actions Office, Department of Preventive Health Services, Army Medical Department Center and School; 1993: pp 1-4.
12. Manning FJ. Morale, Cohesion, and Esprit de Corps in Handbook of Military Psychology. New York: John Wiley and Sons; 1991:pp 531-558.
13. MacDonough TS. Non-Combat Stress Reactions in Handbook of Military Psychology. New York: John Wiley and Sons; 1991:pp531-558.

AUTHORS:

†Medical Corps. Lieutenant Colonel Pincus is currently a Fellow, Psychopharmacology, University of Colorado Health Sciences Center, Denver, CO.

††Medical Corps. Colonel Wymes is Chief of Psychiatry, DeWitt Army Community Hospital, Fort Belvoir, VA.

Setting the (Dental) Record Straight

COL Thomas D. Richardson, DC†

Effective management of dental health records represents a challenging requirement to members of the Army Dental Care System (ADCS). Effective management of records, an intrinsic component of quality dental healthcare, requires a seamless, standardized system which all clinicians can comprehend, research, and use to document clinical findings and treatment. Important information documented in the record must be readily available in standardized format and legible, thus expeditious (so as to facilitate) handling and disposition by clerical staff. Optimal records management enhances the quality of patient care, and aids in the continuity of care in an environment in which both clinicians and patients change locations frequently.

Excellence in records management begins with "corporate ownership." Each member of the ADCS who deals with dental health records must receive the necessary technical training as well as "inspirational" training so that he understands the importance of the task. Once trained and inspired, each member habitually reviews each record handled and acts immediately to correct deficiencies before the record moves to another person or location. The person in possession of the dental record assumes responsibility for the identification and correction of administrative deficiencies it may contain based on the standardized format. Staff personnel invested in such a manner will thus intercept deficiencies within individual records as well as contribute to a shared culture of pride within the organization. Improvement in the overall quality of dental health records, a cornerstone of excellent patient care, will result.

The records audit officer, under authority of the quality assurance committee, augments this effort with periodic review of selected records and feedback to the audited clinician. Audits assist in reinforcing good record keeping habits and serve to strengthen individual

commitment to the standardized format on which we depend.

Assessment of dental health records for accuracy and completeness requires the review of a substantial number of items. A checklist of important items, therefore, can provide a valuable initial or remedial reminder.

This *Dental Record Essential Element Checklist*, although not comprehensive in scope, addresses and prompts attention to the most critical aspects of record management. Clinicians and staff new to the ADCS will find the checklist valuable as they become acquainted with the standardized format.

Dental Record Essential Element Checklist

Medical History:

- Has the medical history been updated and signed by both doctor and patient?
- Has the doctor or the patient completed a written explanation in the space provided for each "yes" response or "check" mark in the "CONDITIONS" section?
- Has a medical warning tag (DA Label 162) been placed on the front of the record jacket if patient has any condition which makes dental treatment unusually hazardous for him?
- Has everything in the medical history, except for the patient's unit and phone number, been written in ink?

Radiographs:

- Does the record have a diagnostic Pantograph?

- Does the patient have at least one set of diagnostic bitewings, if indicated?

Periodic Oral Evaluation:

- Have the soldier and the doctor signed the medical history on this date?
- Has the soldier signed the privacy act inside the back cover?
- Has a screening blood pressure been recorded, and if abnormal, was the patient counseled or referred as indicated?
- Has the periodontal screening and recording index been documented, and does the treatment plan address the patient's needs for periodontal care, if any?
- Have the findings been correctly recorded in part 9, SF 603?
- Has a sequential treatment plan been written which addresses the Class 3 conditions first?
- Has the doctor written his initials and the date in the lower right corner of part 9?
- Have the Class 3 conditions been written in pencil in part 9, REMARKS, and in ink in part 10 (in the narrative)?
- Has the doctor signed his name and rank on the lowest line of the narrative entry in part 10?
- Has the doctor written the designated dental classification for the patient?

Identification:

- Are all the documents contained within the dental health record identified with the patient's name and SSN.

SF 522:

- Other Than Active Duty: Has the patient signed the

detailed 522 prior to any treatment?

- Active Duty: Has the patient signed the detailed 522 prior to any procedure which has significant risk?

Narrative Entries:

- Is the date written at the beginning of each entry?
- Does the entry state the type of exam performed, if any?
- If the periodic oral evaluation was performed, does the narrative so state?
- If the patient was symptomatic, does the entry reflect the diagnostic process, differential or definitive diagnosis, and treatment or disposition?
- If applicable, does the entry document the type, amount, concentration, and concentration of vasoconstrictor of the local anesthetic used?
- If a procedure was performed, did the entry first name the category (such as OPER or OS), then the tooth number, followed by the approved description of the procedure?
- Did the doctor sign his name legibly on the lowest line of the entry, and enter the patient's dental classification on the far right side?
- Did the doctor graphically record in ink the completed treatment on the left side, top, and erase it from the right side, top?
- Did the doctor update the periodic oral evaluation at the completion of the treatment plan?

Class 3 Designation:

- Are the Class 3 conditions written clearly in pencil in REMARKS, SF 603, and written in ink in the narrative?
- Does the treatment plan first route the patient to

that therapy which will remedy the Class 3 condition?

Prescriptions:

- Has the complete prescription, to include the drug, strength, amount, and regimen been recorded in the narrative?

Individual Stick Slip:

- Has the form been completed in detail and the information recorded in the narrative?

Daily Dental Treatment Log:

- Does the log agree precisely with the treatment as reflected in the patient's record?

The ADCS, perhaps the largest "group dental practice" in the world, serves the needs of a highly mobile force which must be fit to deploy on short notice. Providing the care and supervision to ensure dental readiness to the force and promoting optimum oral health for all beneficiaries remains our primary focus. Maintaining the highest standards of care requires a commitment to effectiveness and efficiency, and optimal records

management represents a necessary component of excellence in patient care. Substandard records management, however, can generate significant problems related to therapeutics, medico-legal issues, forensics, and dental readiness. The *Dental Record Essential Element Checklist* can assist both the clinician and the clerical staff in improving the overall quality of dental health records and thus better support our efforts in promoting dental readiness and optimum oral health.

Bibliography

Headquarters Department of the Army. Recording Dental Examinations, Diagnoses, and Treatments; and Appointment Control. TB MED 250; February 1990.

Compiled by: Office of The Surgeon General, Washington, DC; American Dental Association Current Dental Terminology and Department of Defense Laboratory Codes; 1997.

Richardson,TD. The Dental Health Record; 1998.

AUTHOR:

†Dental Corps. Colonel Richardson is the Chief, Professional Development Branch, Department of Dental Science, Academy of Health Sciences, U.S. Army Medical Department Center and School, Fort Sam Houston, TX.

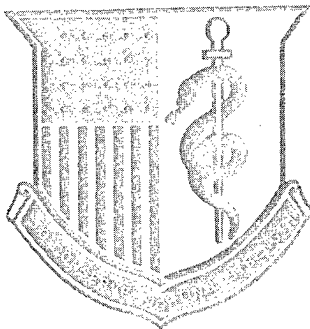

Case Studies in Aviation Medicine: Bosnian Deployment

CPT James R. Bean, SP†

The deployment of an aviation unit forward involves not only the movement of materials and personnel, but also planning for their healthcare. Due to the flying duty of members of the unit, there are several things that need to be looked after and planned for that a nonaviation unit does not address. The article will give the aeromedical physician assistant (APA) a base to work from in deploying a unit forward to the Bosnian Theater. Several health problems and medical conditions can affect the mission and there are case histories to highlight problems encountered as well as ways of dealing with or preventing them. This article will address what items of equipment, forms, and personnel will be needed to deploy into the Bosnian Theater.

Introduction

The deployment of forces to Bosnia-Herzegovina includes several aviation units. Aviation units have several unique needs, in addition to the normal issues of any deploying unit. This article will help commanders and medical providers, including the flight surgeon (FS) or APA, plan for deployment. This article highlights three phases: predeployment, deployment, and redeployment/postdeployment. Several situations which developed during this current deployment will be discussed as well.

Predeployment

Knowing the present medical readiness of the unit is extremely important. In a majority of cases, the assigned FS or APA will be aware of any problems that will need to be addressed before deployment. If the unit has no organic medical personnel, this information should be available through the unit's overseeing medical facility. The information should include, but not limited to: immunization status, profiles, and waivers as well as the general state of health of the unit. Another source of this information might be the unit's S-1 (personnel section). Normally not an area that keeps medical information, the S-1 often tracks information on soldiers for the commander. The information may be incomplete but is a good starting point.

All immunizations must be current and provisions should be made to ensure currency throughout the deployment. If there are immunizations that are unique to the area (such as Anthrax) plans should be made to begin the series. This information is available through the Armed Forces Medical Information Center and can be accessed through various means. Remember to allow for the 12 hours of mandatory grounding of air crewmembers following administration of immunizations as defined in the Army regulations and doctrine.¹⁻³

Case 1. History

A 22-year-old male was seen at home station with persistent hip pain which started after jump school. Referred to orthopaedics due to chronic femoral head changes on x-ray and a history of Legg-Perthe's Disease, orthopaedics recommended P-3 profile and separation from service. Deployed because the unit didn't think it would make any difference, he was eventually redeployed to home station with continuing pain and separated with disability.

Ensure that all profiled or waived individuals are identified. Proper disposition will prevent manpower problems during the deployment. The loss of key individuals for known problems should be prevented. Individuals that are carrying a "hip pocket" profile (no

record of profile in medical record or with company and used only to get out of activity) should be sought out. The institution of a policy, which states that a profile not filed in the medical record is not valid, will help identify the profiles and is normally supported by command. The identification of all profiles will allow for the timely completion of medical work-ups for permanent profiles and subsequent deployability. Any pending or possible waivers should be addressed early to ensure that all tests or consults needed to continue or initiate them are completed prior to deployment.⁴ Reserve components will need to be especially diligent in ensuring that all medical conditions for which an aviator is being treated are documented.

The general health of the unit should be ascertained to determine if there are individuals that need surgery, work-up for chronic illness, psychological evaluation or care, or chronic treatments or medication that may not be available in theater. This will entail a comprehensive chart review.

Case 2. History

A 28-year-old female aviator presented to the deployed aviation medical clinic with 2-month history of abnormal vaginal bleeding without cramps or other problems. She denied pregnancy and when asked about birth control stated "wasn't using any." She stated that she and her husband had been trying to conceive a child for 9 months prior to deployment. Her human chorionic gonadotrophin was positive and the patient returned to home station where she spontaneously aborted. She was returned to the theater following a brief convalescence.

If there are female members of the unit, plans for predeployment pregnancy testing and use of some form of effective birth control should be addressed with the command. Early pregnancy can be without problems or symptoms and testing will aid both the command and the soldier in deployment. It may be worthwhile to test 1 month prior to deployment and again after 1 month of being deployed to ensure no pregnant soldiers are deployed into theater.

Case 3. History

A 42-year-old male with a known history of

coronary artery disease, which required stenting in the past, presented to the deployed emergency treatment area with a 3 hour history of chest pain. Fortunately, his medical provider at his home station advised him to carry a copy of his medical record. This aided in treatment and allowed timely treatment and evacuation.

In all forward deployments, the medical records remain at home station. The DA Form 8007, Individual Medical History, is the only record of medical care taken into theater. This single sheet will have all the known medical and dental information about the soldier. If a soldier has a complicated or significant medical history, it is important to make sure a copy of his medical record deploys with him.

Case 4. History

A 34-year-old crewmember on deployment presented for his annual flight duty medical exam (FDME). During the electrocardiogram (ECG) it is noted that he has evidence of first degree atrioventricular block. This is a condition that might cause an aviator to be grounded unless this was a condition which had been worked up in the past and a waiver was granted. The unit had not sent a copy of the last FDME with the aviator on deployment. The soldier was grounded until a copy of his last FDME and ECG was sent for review. Communication problems prevented faxing copies and took 4 weeks by mail. Review showed no change in his condition and he was returned to flight duties.

The DA Form 8007 should be supplemented with a copy of the last FDME and any waiver information about the crewmember. If an aviator has a waiver, a copy of that should be placed in the flight record as well. This information will allow the FS or APA to determine what procedures will be needed to keep the waiver current.^{5,6}

Equipment needs must be addressed at this stage as well. Not only will the unit deploy with the standard medical chests needed to take care of casualties and sick call but also the equipment needed to perform annual FDMEs. Other testing unique to the aviation community will have to be addressed as well.

Communication with the units that have been or are

presently in the Area of Responsibility (AOR) and units that will be supported is important. Some units do not deploy with a FS or an APA due to shortage or only a small portion of the unit is being deployed. The FS or APA will not be part of the deployment movement and must coordinate his own movement to the unit. Most likely there will be no medical equipment, supplies, or records sent. It is important to establish communications to attempt to get some materials sent with the unit. Use any means available to find out the information needed. In Bosnia, e-mail is probably the most universally available means; most camps have Internet access. The phone system varies from camp to camp; all have DSN (formerly AUTOVON) lines to contact other facilities in Germany (OCONUS) and continental United States (CONUS). In addition, some have Sprint while others have mobile subscriber equipment (MSE). The systems are frequently inoperative due to weather or downed lines.

The chain of command is the best resource to care for family issues. Using the family support groups to identify the families in crisis will save many headaches and problems during the deployment. During this deployment there have been several instances where problems developed at home station due to financial, psychological, or language difficulties that were either overlooked or not addressed prior to deployment. For example, late term pregnancies, which suddenly developed problems after the service member was deployed. In some cases, these problems were known to unit members or the health providers of the patients before deployment and were not communicated to the unit.

One last important planning item is accident investigation. A good outline of what to bring and how to handle this very real possibility can be found in the U.S. Army Aviation Medicine Handbook.⁵ There is also a section on handling body fluid/blood specimens for toxicology screen for aircraft mishaps. Remember, don't do the tests locally, maintain the chain of custody IAW AR 600-85 and include DD Form 1323, Toxicological Exam, with the specimens. All specimens need to be sent to the Armed Forces Institute of Pathology (AFIP) in Washington DC. There is also a listing of phone numbers to find information at Fort Rucker, AL.

Deployment

The actual length of deployment has a significant bearing on planning for the mission. With the advent of hepatitis A vaccine, the use of immune globulin as protection against hepatitis A is no longer required. Try to ensure that all deploying personnel have received at least the first immunization. If one must administer immunizations in the theater then ordering, storing, and the administration of vaccines will have to be planned for. The anthrax vaccine, a multiple dose vaccine, is a good example of a vaccine that requires detailed planning to administer in the proper time frame. The length of time in country and the time of year are important because of the seasonal variation in most diseases.

Case 5. History

A 34-year-old Polish soldier presented with flu-like illness of 3 days duration. He had an unremarkable examination except for temperature of 102°F. Personnel had noted an increase in the number of mice in the area. During his evaluation, preventive medicine personnel interviewed the patient and he admitted to keeping some mice as pets. Laboratory testing confirmed a mild case of Hantavirus. The patient required 5 days of hospitalization and was then released back to duty.

Hantavirus is more of a problem in the winter to early spring due to the increased contact with the rodent population. The sleeping tents and connexs have many openings, which allow the admission of small animals. Preventive medicine is an excellent source of information and maintains surveillance in the camps. They also have handouts, wallet cards, and other devices to help the command and soldiers learn about the various health problems in the AOR. If deploying with a preventive medicine team, establish early communication to aid in medical planning as well.

Plan for the equipment that will be needed. This will not only include the sets, kits, and outfits that would be needed, but also the material to do the paperwork and FDMEs. The facility at Tuzla Main (Eagle Base) is the only Level III military facility in Bosnia. This facility has laboratory, radiology, and ECG capability and is the only

location with optometric and dental personnel. All the base camps must send their soldiers there for testing. At the time of my rotation, there was no capability to do audiometry. The regional FS has forwarded a policy to the United States Army Aeromedical Activity at Fort Rucker (USAAMA) concerning the inability to complete all testing. Based on this memorandum, the USAAMA is approving the FDMEs with the understanding that audiograms will be forwarded to the Center within 90 days of the flight crews returning to home station. Planning to hand receipt a portable unit will allow the completion of all FDMEs. One piece of equipment that will speed the FDME process is a Titmus machine. This will allow a trained medic to evaluate the vision of any aviator and thus the immediate need for an optometrist is reduced (unless there is a change in vision or prescription). If this is not available, testing of near/far, color vision, and depth perception may be done with wall and hand charts, Ishihara pseudoisochromatic plate test, and a Verhoeff test box. Even if laboratory testing is unavailable locally, a small centrifuge would allow blood to be drawn, spun down, and the serum separated for transport to a lab. Blood could be kept until the next scheduled run to the hospital. If this is unavailable, scheduling blood drawing on the days of runs to the hospital would be an alternative.

Bring any forms, Army Regulations (ARs), and Aeromedical Policy Letters (APLs) that might be needed. The copy machines in country do not function well and the number of copies they can make at one time is limited. If at all possible, computer generated forms and the computer programs for all ARs and APLs (The Aeromedical Program or the Ultimate Flight Surgeon's Handbook available through Fort Rucker; www.rucker.amedd.army.mil, or the U.S. Army Flight Surgeon Society) should be taken. The ability to use a laser or bubble jet printer will greatly assist any medical administrative section and allow the modification of the forms to fit the mission. This will decrease paperwork space and weight and allow more room for other medical supplies.

If deploying with a unit, make sure all equipment is packed. If you're not deploying with the unit, contact them and make sure they pack the needed equipment or procure the equipment before deploying.

The ancillary services for the FDMEs are located at the Tuzla Main. Although there were no crewmembers needing new or continuation of waivers during my rotation in Bosnia, new problems could be evaluated by the specialists who were assigned to the Tuzla Main. Different specialty physicians are sent with each rotation. If a crewmember needs consultation for a waiver, they might have to go to Germany or CONUS for completion.

The medical staff during my rotation at the Blue Factory could not assist with flight physicals due to competing missions. Try to bring medics or other staff to help with FDME and sick call. The heavy duty rotation of the nursing/ancillary staff reduced their ability to aid in the aviation medicine. When an individual began to understand the process, they rotated to another section or camp. Due to the nature of the mission of the aviation unit I was assigned to (MEDEVAC), the flight medics were not available to help with sick call or FDMEs.

As most FS/APAs know, flight crews often wait until the last minute to complete their FDMEs. This makes additional testing or consulting for a new waiver during the birth month difficult. An aviator may be unable to fly until this testing is done. The commander at my unit was very supportive of the process and made it clear that extensions for incomplete FDMEs would be granted for exceptional reasons only.

Awaiting waiver approval can be a burden on the remaining crews due to loss of a rated crewmember. Fortunately, e-mail communication with the Aeromedical Center at Fort Rucker, as previously mentioned, is possible. A temporary waiver may be granted on the information provided by e-mail or telephonic consult.

If a crewmember needs medication, that medication must be in accordance with the APLs and AR 40-8. This will allow faster processing of a waiver. These medications may not be available in country, thus complicating the treatment plan and waiver requirements.

There have been several crewmembers interested in smoking cessation. Nicotine patches were available. Setting up classes or support groups to aid in cessation has been a

problem. The mental health team cannot become involved in this due to competing missions. Coordinating with mental health and a family practice physician prior to deployment may prevent difficulty in smoking cessation groups. Planning for this prior to deployment will help, but remember to discuss mandatory grounding with individuals on flight status prior to starting the patches (72 hours after starting the medication).

There have been many opportunities for training while deployed. The Advanced Cardiac Life Support course, grand rounds and continuing medical education is available. In addition, opportunities in teaching the Combat Life Saver, Basic Trauma Life Support, and the Emergency Medical Technician are available as well.

The type of deployed unit will determine what type of training is needed. For example, being deployed with an air ambulance unit involved training and sustainment of skills for advanced procedures such as endotracheal intubation, cricothyrotomy, and needle chest decompression; other aviation units may not need this training.

There are also areas that the chain of command may ask the FS or APA to teach as part of annual flight training requirements. These might include topics such as spatial disorientation or the discussion of pertinent regulations.⁷ Maintaining a line of communication with the command will prevent problems during the course of the deployment. Making sure the DA Form 4186 (Medical Recommendation for Flying Duty) are both complete and clear will allow the commander time to adjust schedules and help aviators understand what's expected of them in order to return to flight duty.

Redeployment/Postdeployment

Case. History 6

A 20-year-old aircrew member presented to his home station Troop Medical Clinic with the complaint of a sore on his leg that would not heal. He stated that the sore had been there for about 3 months, at times itched, but primarily he complained about it not healing. One of the possible exposures outlined in a post-Sinai deployment memorandum from his unit was for Leishmaniasis.

Testing confirmed this diagnosis. This information saved time and possibly further problems for the soldier.

During the redeployment/postdeployment phase, the two most important medical issues are surveillance postexposure and risk awareness. In most cases, there will be soldiers that have deployed with the unit that will return to their own unit. These individuals will be lost to local medical follow-up. A redeployment memorandum stating what kinds of diseases they might have been exposed to should be placed in the medical record to alert other providers to illnesses they may not otherwise consider in a garrison situation.⁸

Risk awareness should be highlighted during any briefing with the command or the soldiers. This will clarify that there are factors they have been exposed to which can affect their health. Notices on unit bulletin boards should also be used to remind soldiers not to ignore problems which might be the start of a serious illness. All providers should be used to provide other information and assistance to soldiers that develop psychological or social problems.

Summary

The key points to remember during the predeployment are the presence of information resources and the unit time constraints. During the deployment, the priority is to keeping the unit healthy and on flying status. Utilize all attached medical assets to ensure that the unit mission is completed. Medical surveillance is the most important factor in the redeployment/postdeployment phase. The need to make sure that crewmembers receive timely care for medical problems which may be caused by deployment can not be over emphasized. In addition, attached soldiers who return to their units are monitored by the medical team at that unit which must be briefed on the possible problems through timely communications.

References

1. United States Army Aeromedical Policy Letters. January 1997.
2. AR 40-8, Temporary Flying Restrictions Due to Exogenous Factors. October 1976.

3. ATB 2 Administrative Guide for U.S. Army Flight Surgeon. January 1997.
4. AR 40-501 Physical Profiles. 1995.
5. Crowley JS. *United States Army Aviation Medicine Handbook*. 3d ed. The Society of U.S. Army Flight Surgeons, Fort Rucker AL; 1993.
6. United States Army Aeromedical Technical Bulletins. January 1997.
7. DeHart RL. *Fundamentals of Aerospace Medicine*. 2d ed. Baltimore Md: Williams and Wilkins; 1996.

8. Auerbach PS. *Wilderness Medicine: Management of Wilderness and Environmental Emergencies*. 3d ed. Mosby, St. Louis; 1996.

AUTHOR:

†Army Medical Specialist Corps. Captain Bean is assigned to the Physician Assistant Branch, Department of Medical Science, Academy of Health Sciences, U.S. Army Medical Department Center and School, Fort Sam Houston, TX.



The Letterman System for Casualty Treatment and Evacuation

MAJ Kyle D. Campbell, MS†

The advent of the 19th century brought about a continued improvement in the technology of warfare with tremendous advances in the killing power of weaponry. "Moreover, the extremely high casualty rates caused by these more lethal weapons forced political and military authorities to improve medical care as a way of conserving expensive manpower."¹ The importance of maintaining trained and experienced soldiers cannot be overstated and remains a key focus even today as demonstrated by the creed of the Army Medical Department, "to conserve the fighting strength."

This article addresses Dr Jonathan Letterman's development and institution of a system of casualty evacuation and treatment that sought to conserve the fighting strength of the Union Army. Letterman's implementation of an ambulance corps under medical control and his revised field hospitals were brilliant applications with a profound impact during the American Civil War and remain the basis for our military medical doctrine today. The Letterman system developed from, and corrected for, the military medical systems of France, Britain, and Russia during the period of 1845-70. While this article will describe the major components of the Letterman system in terms of his concepts of evacuation and treatment, the primary focus is on his casualty evacuation system.

"At the start of the 19th century, no Army had established an independent military medical service under the control of medical officers for treating the sick and wounded, and no nation could routinely provide a trained medical staff, medical supply structure, or medical personnel adequate to deal with normal casualty loads. Yet, by the end of the century, every major Army had an independent, professionally trained, and sufficiently manned military medical service complete with fully articulated

ambulance systems for reaching, treating, and evacuating the huge numbers of casualties that had never before been seen on the field of battle."²

During this period (1792-1815), the French were in the forefront of military medical services mainly due to the efforts of Dr Dominique-Jean Larrey. Larrey attempted to improve the system for casualty evacuation by utilizing dedicated units of stretcher-bearers in conjunction with casualty evacuation vehicles capable of carrying two to four stretchers. These vehicles were "light, enclosed wagons with strong springs in which the stretchers were suspended."³ Despite all of Larrey's innovations, the French failed to capitalize on their medical service capabilities and suffered a series of medical disasters in battle after battle of the early 19th century. During the Crimean War (1854-55), the ambulance system was a complete failure and never achieved the level of performance that Larrey had hoped. "While transport was sometimes provided for medical units, most often they would use the empty food carts and supply wagons that had previously delivered supplies to the front. Usually, no medical personnel attended the wounded in movement; and when medical personnel were in attendance, their numbers were pitifully small."⁴

Like the French, the British suffered a medical disaster during the Crimean War. They lacked dedicated litter bearers and their ambulance corps was sadly inadequate. Although they had prototypes of the Larrey-type ambulance evacuation wagons, they had far too few to provide adequate support. The British had not learned from Waterloo (1815) where Wellington suffered a reduction in combat power due to the lack of evacuation assets. "Wellington himself noted that after the battle no fewer than 1,875 men were unaccounted for. They were later found to have helped their comrades to the medical

tents and then remained there until the battle was over.”⁵⁵

While the Russians had the highest percentage of medical men within the force, the quality of the medical support was terrible in the Crimea. “The few hospitals that existed were makeshift affairs with few provisions made for adequate beds or linen, and no provisions of any kind for an ambulance service.”⁵⁶ The Russians, like the French, transported the wounded to the rear using only the wagons that were not currently in use by other elements of the Army. One positive development to come out of the Russian experiences in the Crimean War was the expansion on Larrey’s triage system. Larrey is considered the first military physician to “introduce a formal policy of combat triage.”⁵⁷ But it was the Russian Surgeon Nikolaj Iwanowitsch Pirogow who directed that the surgeons at the battlefield dressing stations limit themselves to providing rapid assessment of the wounds, initial necessary treatment, and the triaging of all casualties according to severity and priority for further treatment. “Pirogow’s policy of the dispersion of casualties and his insistence on careful sorting according to the kind of treatment remain the basic rules of war surgery today.”⁵⁸

During this same time period, the Americans had just won the Mexican War (1846-48) and were dealing with the same difficulties that the French, British, and Russians faced. In an effort to improve the American military the Secretary of War, Jefferson Davis directed Captain George B. McClellan to prepare an after-action report on the Crimean War. This report included McClellan’s recommendation for the development of an Army ambulance corps. The recommendation led to the appointment of a committee to consider numerous ambulance designs, however, “by 1860 the Army had rejected all designs and no ambulance corps was created.”⁵⁹ Although a few Larrey-type ambulances were used, the old practice of begging available wagon transport from the quartermaster prevailed.

Nothing that the Americans had seen in their limited history prepared them for the sheer magnitude of slaughter that was the Civil War. “The exponential increase in the killing capabilities of the weapons, especially the improvements in the rifle, produced rates of casualties beyond the imagination of commanders and

military medical personnel.”⁶⁰ In the first years of the Civil War, the Union armies were doomed to repeat the same mistakes made by the French, British, and Russians during the early part of the 19th century. Union commanders were forced to commandeer vehicles off the streets of Washington to evacuate the wounded during the battle of Bull Run. “At the battle of Wilson’s Creek, the wounded could not be moved for 6 days due to the lack of ambulances.”⁶¹

The public outcry over the abysmal medical conditions led the Surgeon General, Dr William Hammond, to appoint Dr Jonathan Letterman as the medical director for the Army of the Potomac. “Letterman created an ambulance corps built around the Larrey model, and each Army corps had its own organic medical transport assets under medical direction.”⁶² Each regiment had between two and three ambulances while each division had ambulance trains with approximately 30 vehicles. The medical officer at each succeeding level was placed in charge of the employment of these ambulances. In each division, a line officer was tasked with managing all the support issues such as parking, veterinary services roll call, and extra duties. This line officer reported directly to the division surgeon or medical director to maintain medical command and control. Letterman further directed that ambulance wagons only be used for medical evacuation and he removed them from the command and control of the quartermaster. This prevented the critical evacuation assets from being “appropriated at a crucial moment by the local commander or quartermaster.”⁶³

The dedicated ambulance corps proved its worth during its first real test in the battle of Antietam. The wounded of the Union Army were reached and evacuated within 36 hours despite the fact that thousands of these casualties were scattered over a 6-mile area. This success was validated at the battle of Fredericksburg when “all 10,000 Union wounded had been located and cleared through the aid stations within 12 hours.”⁶⁴ A secondary area that ensured the success of the ambulance corps was Letterman’s “knowledge of the service that taught him how much better it was to take men who had already been drilled and disciplined, and who were identified with the regiments whose wounded they were to care for; and as their duties in the ambulance corps would not exempt

them from the dangers and exposure to which their regiments had to submit, the spirit of comradeship was thus kept up."¹⁵

While the establishment of the Letterman system did, in fact, remove some soldiers from the combat units, it actually provided a significant increase in manpower on the front lines. Letterman accomplished this through two primary actions. First, he ensured that the ambulance drivers and litter-bearers wore distinctive uniforms and were the only individuals authorized to remove the wounded from the battlefield. This corrected the problems Wellington noted at Waterloo and "reduced the loss that normally resulted when several men left the line to transport their wounded comrades to the aid station."¹⁶ Second, Letterman changed the structure of the field hospitals. He changed the regimental hospitals into front-line aid stations to conduct secondary triage, based on the principles of both Larrey and Pirogow, by controlling bleeding, bandaging wounds, and stabilizing the seriously wounded for further evacuation to higher level care. At this point, he also instituted a "systematic inspection to screen those held for possible return to duty before deciding what patients to evacuate and thus prevent considerable manpower loss by reducing unneeded evacuation."¹⁷

Letterman instituted a mobile surgical field hospital located behind the front-line aid stations to conduct major operations in the division rear area. "These hospitals were the critical link, missing for most of military medical history, between the front-line aid stations and the rear-area general hospitals."¹⁸ The entire medical system was now under medical control from the front lines or point of injury all the way back to the rearmost hospitals. This provided for better treatment, more responsive evacuation, and a higher number of trained and experienced warfighters on the front lines.

The utility and success of the Letterman system was so apparent and was demonstrated so consistently that Surgeon General Hammond recommended that all Union armies adopt it. Indeed, "Congressional legislation in 1864 extended the Letterman system to all field armies."¹⁹ Although the military medical system was demobilized with the rest of the Army at the end of Civil War, the Letterman system provided a template for all military

medical systems to model themselves after in time of war. The Letterman system demonstrated unequivocally the need for medical control of the entire evacuation chain, from the point of wounding through each successive level of care in dedicated medical evacuation vehicles. "The components of the Letterman system for organizing the care and evacuation of wounded became a permanent part of American military medical doctrine and influenced military medicine throughout the world."²⁰

References

1. Richard AG, KS Metz. *A History of Military Medicine*. New York: Greenwood Press; 1992:p 145.
2. Ibid, p 147.
3. Gunther ER. *The Art of Warfare in the Age of Napoleon*. Bloomington, Indiana: University Press; 1980:p 228.
4. Gabriel, p 124.
5. Ibid, p 168.
6. Ibid, p 178.
7. Ibid, p 158.
8. COL, Trevor ND, COL, Franklin DM, eds. *International Military and Defense Encyclopedia*. Washington: Brassey's (U.S.) Inc; 1993:p 1704.
9. Gabriel, p 188.
10. Ibid, p 181.
11. Ibid, p 188.
12. Jessup JE, Ketz LB, eds. *Encyclopedia of the American Military*. New York: Charles Scribner's Sons; 1994:p 1591.
13. Ibid, p 1591.
14. Gabriel, p 189.
15. Bennett AC. "Memoir of Jonathan Letterman." *In: Journal of the Military Service Institution*. New York: Putnam's Sons; September 1883:Vol IV, No.15:p 7.
16. Gabriel, p 189.
17. Ibid, p 190.
18. Gillett MC. *The Army Medical Department 1818-1865*. Washington DC: Library of Congress; 1987:p 228.
19. Gabriel, p 190.
20. Jessup, p 1591.

AUTHOR:

†Medical Service Corps. Major Campbell is the Commander, 498th Medical Company (Air Ambulance), Fort Benning, GA.

Treating Rampant Caries: Winning the Battles, Losing the War

CPT Jack F. Thompson III, DC†
COL Robert D. Meyer, DC††

Introduction

The most well-intentioned practitioner, in their fervent endeavor to restore a patient's dentition, may subject the individual to endless appointments and expense in a futile attempt to stay ahead of dental disease. The inevitable result of treating only the sequelae of caries, and not the etiology, dooms the patient to years of restoration replacement and often results in edentulousness. This is borne out by the fact that 70% of all restorations are replacements of existing restorations.¹ Our profession has studied caries etiology, detection, and spread and treatment modalities; yet this devastating disease continues to haunt us.²⁻⁹ Our goal, as healthcare providers, should be to intercept and arrest caries at its earliest presentation rather than to merely respond to its destructive sequelae.¹⁰ Several cases are presented which document how considerable time and expense were invested in restoring dentitions, only to have them repeatedly fail due to recurrent caries. The purpose of this article is to dramatically illustrate how important it is to treat the disease process as aggressively as we treat its manifestations.

Case Studies

Case 1.

Chief Complaint:

This 42-year-old male states, "my mouth is a mess...loose teeth and cavities...can't put pressure on hard foods, mostly on lower back teeth." (Figure 1)



Fig 1. This patient presented with 14 carious lesions and a history of 40 restorations, 8 extractions.

16 year Dental History Summary:

- 16 documented annual exams, 8 documented cleanings.
- 6 teeth restored from 3 to 6 times, each resulting in extraction
- 40 total restorations, 8 extractions
- Patient currently presents with 14 carious lesions (Figure 2)

Present treatment plan requires 12 extractions with maxillary complete denture, mandibular partial denture.

Comments:

- Long history of poor oral hygiene noted in patient record and does not floss or brush regularly.

- As a tank commander, he often uses his toothbrush to clean weapons rather than his teeth.

- He drinks 3-6 sodas per day at work and 3-8 glasses of sweet tea in the evening.

- His father received complete dentures at age 45, and the patient relegated himself to the same fate.



Fig 2. No. 18 was restored 6 times before it was finally extracted.

Case 2.

Chief Complaint:

A 39-year-old male states, "I want to eat better and I want to fix the way my teeth look." (Figure 3)



Fig 3. This patient presented with 12 carious lesions and a history of 66 restorations, 8 root canal treatments, 12 extractions, and comprehensive orthodontic treatment.

16-Year Dental History Summary:

- 15 documented annual exams, 8 documented cleanings
- 14 teeth restored 3-6 times
- 66 total restorations, 8 root canal treatments, 12 extractions
- Comprehensive orthodontic treatment

Patient currently presents with 12 carious lesions.

Comments:

- This patient has frequent sick calls, mainly for tooth pain caused by caries.

- Patient able to change his oral hygiene habits, with appropriate incentives, but does not maintain these changes. In 1992, he was refused orthodontic therapy until his oral hygiene improved and his operative needs were met. He cooperated and received complete orthodontic treatment. The patient claims to understand the importance of his participation in his oral health but fails to follow through. Upon completion of orthodontic therapy, his oral hygiene deteriorated again.

- His mother received complete dentures at age 16.

- He smokes one pack of cigarettes and consumes 4-6 sodas per day.

- The patient continues to request expensive and time-consuming aesthetic procedures.

Case 3.

Chief Complaint:

This 35-year-old male states, "nobody has finished my dental work in the past 5 years." (Figure 4)

4-Year Dental History Summary:

- 3 documented annual exams, 1 documented cleaning

- 10 extractions, 8 due to caries
- 5 teeth restored 2-3 times
- 29 total restorations, 5 root canal treatments
- 9 fractured restorations, 2 defective restorations, and 1 endodontic retreat

Patient currently presents with 10 carious lesions and failed 4-unit fixed partial denture.

Comments:

- This patient feels that every treatment he has received has failed.
- His oral hygiene is poor.
- He smokes 1/2-pack cigarettes per day and has frequent sugar encounters.

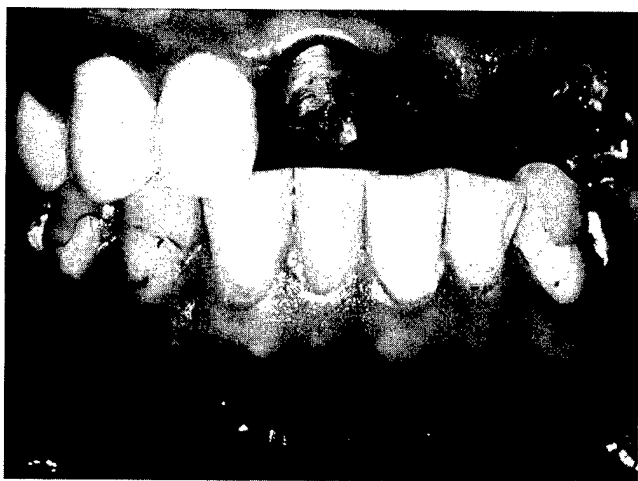

Fig 4. This patient presented with 10 carious lesions, failed 4-unit fixed partial denture and a history of 29 total restorations, 5 root canal treatments, and 1 root canal retreatment.

Discussion

The etiology of caries, as well as its diagnosis and treatment, is well-documented. In most patients who do not have overlying host resistance factors, it is no more

complex than: bacteria + frequent sugars → acid → caries on a susceptible tooth.² Dentists have a reasonable understanding of the relationship between the cause and effect of caries and combined with modern techniques and materials for restoring teeth, should be capable of virtually eliminating this disease. Unfortunately, we are not always winning the war against caries. These three cases dramatically illustrate how important it is for the patient and healthcare provider to work together.

As a multifactorial disease, it is not always easy to identify, truly understand, or quantify the true cause of our failure to control caries. The tendency for poor patient compliance with oral hygiene and frequent sugar intake is often passed on from generation to generation. Combining this with poor patient management and follow-up, often results in progressively destructive recurrent caries. As dental professionals, we may not be providing the best service to our patients by continuing to restore rampant caries without seriously addressing the causes of caries and controlling the disease process with a reasonable degree of consistent patient compliance. The healthcare provider's role must include patient education and preventive measures to include fluoride treatment, quality restorations, and follow-up to ensure compliance. Patients' perceptions and attitudes have to support the ideal that taking care of their teeth is a worthwhile endeavor. If we can't motivate the patient to do their part with regard to oral hygiene, nutrition, and maintenance, then we must carefully re-evaluate our treatment plan and adjust accordingly.⁷⁻¹⁰

In general, the presented cases failed primarily due to poor oral hygiene combined with frequent sugar contact. Until good patient compliance is achieved, lean towards more extractions, large amalgam restorations, and resin interim partials. Avoid fixed restorations as much as possible. Use glass ionomer or resin ionomer restorations and bases, amalgam over composite when possible, restorative resins and sealants, fluoride rinses and/or trays with fluoride gel, frequent cleanings, and regular recall appointments stressing oral hygiene and nutrition counseling at every opportunity. Only after the caries process has stabilized over an extended period of months to years should extensive oral rehabilitation be considered.

Summary

With these documented cases, we hope to raise the profession's awareness level to the need for prevention and caries control before attempting extensive, time-consuming, and costly restorative procedures. "An ounce of prevention is worth a pound of cure" should be an axiomatic philosophy for the treatment of dental disease. Rampant caries is not an inevitability. Control of the disease process through prevention and maintenance, with full patient compliance, is every bit as important as the restorations we provide.

References

1. Mjor I. Amalgam and composite restorations: longevity and reasons for replacement. In: Anusavic D, ed. *Quality Evaluation of Dental Restorations*. Chicago: Quintessence; 1989;61-8.
2. Nikiforuk G. Understanding dental caries. S Karger AG. 1985;158-179:261-287.
3. Williams PA. The chance of the sugar dust caries? *The Br Den J*. August 5, 1995; Vol 179, No. 3.
4. Parkhouse RC. Further thoughts on the sugar dust caries. *The Br Den J*. October 7, 1995; Vol 179, No. 7.
5. Paterson A. Low fat caries. *The Br Den J*. August 10, 1996; Vol 181, No. 3.
6. Helderman, et al. Cariogenicity depends more on diet than the prevailing mutans streptococcal species. *J Den Res*. January 1996; Vol 75, No. 1.
7. Caries diagnosis and risk assessment: a review of preventive strategies and management. A special supplement to *JADA*. June 1995; Vol 126.
8. Powell LV. Caries risk assessment: relevance to the practitioner. *JADA*. March 1998; Vol 129.
9. Loesche WJ. Dental caries. A treatable infection. Automated Diagnostic Documentation, Inc; 1993:291-476.
10. Anderson MH, et al. Modern Management of Dental Caries: The Cutting Edge is not the Dental Bur.

AUTHORS:

†Dental Corps. Captain Thompson is currently assigned as a general dentistry officer, 561st Dental Company, Vilsek Germany.

††Dental Corps. Colonel Meyer is the Assistant Program Director, AEGD 1-Year Residency Program, Fort Carson, CO.



Providing Echelon II CHS to a Digitized Fourth Brigade

MAJ Barbara R. Holcomb, AN†

Fully maximizing the flexibility and agility of the digitized division can result in major task organizational changes. These changes result in additional support relationship changes and create a new set of challenges for logistical support. One of these challenges is in providing Echelon II combat health support (CHS) to a fourth brigade.

Prairie Warrior (PW) is an annual simulation driven exercise conducted at the resident Command and General Staff Officer's Course (CGSOC). The scenario is hypothetical and the enemy forces are all fictional. The purpose of PW is to allow the students to apply the operational and tactical warfighting skills they've learned; use the military decision making process in the emerging digitized environment; and experience the full spectrum of complex operations, as a capstone to their year of learning. The scenario for PW changed in 1998 from a European focus to a Pacific Command focus.

Both Prairie Warrior 1997 (PW97) and Prairie Warrior 1998 (PW98) CGSOC students participating as the digitized division created a fourth brigade using the division aviation brigade, the division cavalry squadron, and a combined arms mechanized battalion with its organic battalion aid station (BAS). The students used the brigade as a maneuver brigade and placed the aviation elements in forward operating bases well out of range of the division's doctrinal Echelon II CHS. The result of this fourth brigade was a combined arms brigade, at times designated as the division's main effort, that had limited Echelon I CHS and no organic Echelon II support.

The implications for the Army Medical Department (AMEDD) are significant, and we must consider this concept as we write Force XXI medical doctrine. Traditionally, Echelon II CHS is provided at the division

level on an area basis and with established support relationships. The aviation brigade and its support battalion was typically located in the division rear area and received its CHS from the main support medical company, now the division support medical company (DSMC). The division cavalry squadron typically received area support from the nearest forward support medical company (FSMC) in a brigade support area or the DSMC, depending on the squadron's location. This new concept of a fourth maneuver brigade creates a situation where it may no longer be practical or reasonable for these units to receive Echelon II CHS from the DSMC in the division rear or from the nearest FSMC.

As the digitized division's medical planner for the PW98 exercise, I found the options for supporting a fourth brigade limited, but not impossible. Along with the PW98 digitized division's surgeon, MAJ Barry Davis and deputy surgeon, MAJ Bob Ruiz, we identified three options. One, employ an area support medical company (ASMC) from the supporting corps level area support medical battalion in direct support (DS) of the fourth brigade; two, employ the DSMC with the division aviation support battalion in DS of the fourth brigade and support the division rear with an ASMC; or three, create an FSMC for the fourth brigade. The latter option would inevitably come from internal resources, given the new size limitations of the digitized division. Each FSMC and the DSMC would conceivably provide treatment teams and ambulance squads, which would detach and create a fourth brigade FSMC.

This third option would only occur when a fourth brigade was planned in a specific mission. Some considerations for this option include command and control issues, equipment, Class XIII, vehicles, and blood. Proactive planning, synchronization, and integration of

the Division Surgeon Section (DSS) in the division headquarters planning cycle will help work to resolve these issues.

The ASMC and DSMC options (Options 1 and 2) are both more viable and each were used in PW97 and PW98, respectively. Both organizations are larger than necessary in a DS role specifically to the fourth brigade. In PW98, the terrain and location of the fourth brigade didn't allow for area support to other units. Using the DSMC in a DS role during PW98 made the most sense because nearly all division units were task organized out to the brigades, so very few small elements remained in the division support area (DSA) and division rear. Corps had several units in the division rear area and it was practical for them to pick up the area support mission for our remaining division units with an ASMC (see figure below). In the PW98 scenario, to leave the DSMC in the

rear and place an ASMC forward would have caused the DSMC to take up the role of a corps ASMC, which is to support corps troops. If corps has an available ASMC, it could be an optimal solution for this situation. Some other considerations in placing the DSMC forward included leaving an ambulance squad in the DSA for some transport capability in the rear, under the control of the Division Support Command headquarters' company. Ideally, the DSMC is also digitized and can communicate more easily within the division than could an analog ASMC. There were ample wheeled ambulance assets forward and we had air ambulance assets placed forward from corps, as well as two forward surgical teams (FSTs). It was difficult to assess the full impact of the evacuation assets and the lack of tracked ambulances because the PW simulation, using the Combat Service Support Training Support Simulation begins evacuation at the BAS rather than the forward edge of the battlefield.

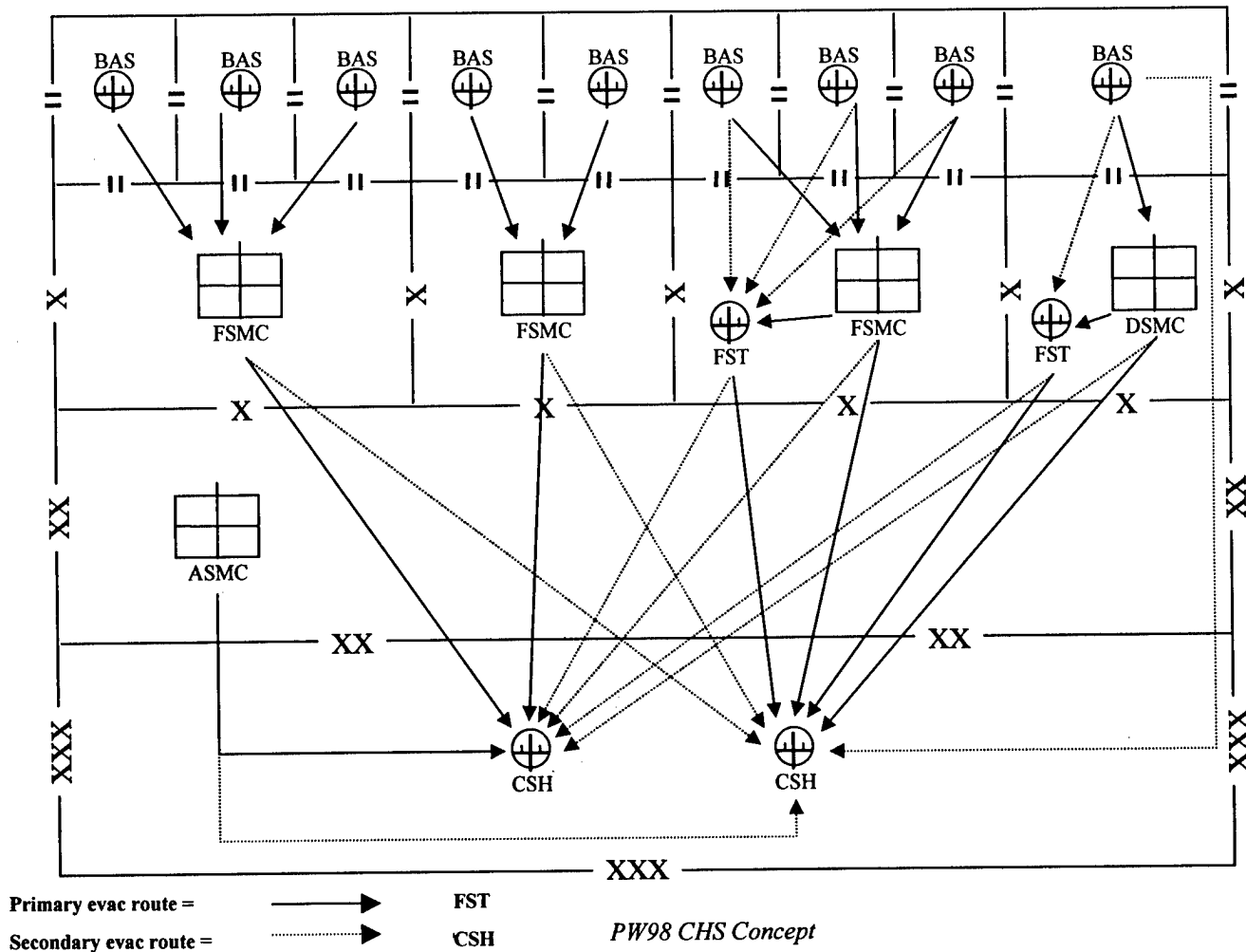

The developing Force XXI AMEDD doctrine must allow maximum flexibility for Echelon II CHS. The above options are all viable; however, careful consideration of the mission, enemy, troops, terrain and weather, and time available will help determine the best support method. The Force XXI medical doctrine must keep its traditional philosophy of area support, *and* must also be able to support creativity in task organization and utilizing the principles of Health Service Support, conformity, proximity, flexibility, mobility, continuity, and control. It is imperative for the medical planners in the

DSS to work closely with the maneuver commanders and division planners to provide adequate and timely Echelon II CHS.

AUTHOR:

†Army Nurse Corps. Major Holcomb is currently assigned to the AMEDD Student Detachment, Fort Sam Houston, TX, with duty at the University of Kansas Medical Center, Kansas City, KS. She will complete her Master's Degree in Nursing Administration in May 2000.

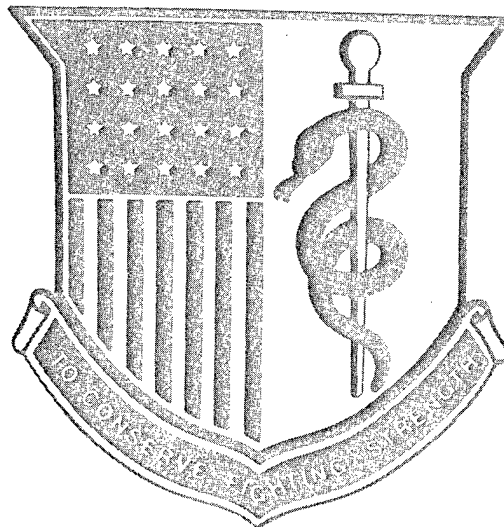

AMEDD Dateline

Wayne R. Austerman, PhD†

- 1 Oct Military Medical Benefits Amendments Act created Civilian Health and Medical Program of the Uniformed Services and greatly expanded the program of inpatient and outpatient medical care through civilian facilities for dependents of active duty military personnel. **(1966)**
- 6 Oct Nurse anesthetist Edward L.T. Lyon became the first male to receive a commission in the Army Nurse Corps when he entered active duty as a 2LT (USAR). **(1955)**
- 12 Oct First U.S. Navy vessel, USS Jupiter, transited the newly-opened Panama Canal. The canal's construction was made possible by COL William Gorgas' eradication of yellow fever and malaria in the Canal Zone. **(1914)**
- 18 Oct Disease and heat exhaustion crippled an entire American infantry regiment within 4 days during operations against the Japanese on the Kapa Kapa Trail in New Guinea. **(1942)**
- 21 Oct Lieutenant Francis Y. Slinger, NC, died of wounds received when German artillery shelled her field hospital unit in Belgium. She was one of 16 Army Nurses who died under hostile fire during World War II. **(1944)**
- 23 Oct Brigadier General Lillian Dunlap, Chief of the Army Nurse Corps, became the first woman to serve as president of a Department of the Army officer promotion board. **(1973)**
- 1 Nov Private First Class Desmond Doss became the first conscientious objector to receive the Medal of Honor. Medic Doss served with the 307th U.S. Infantry Regiment, 77th Infantry Division, during the costly battle for Okinawa. Doss was personally responsible for saving the lives of at least 75 American casualties while under heavy enemy automatic weapons fire. **(1945)**
- James Puckle of London, England, invented the "Puckle Gun," a tripod-mounted flintlock gun fitted with a revolving cylinder to give it a rate of fire of nine shots per minute. The weapon was equipped with an interchangeable barrel and cylinder which permitted it to fire round bullets against Christian enemies and square bullets against Muslims. The "Puckle Gun" was never produced in any quantity. **(1718)**
- 2 Nov Corporal James B. Gresham and Privates Thomas E. Enright and Merle D. Hay became the first American soldiers to die in action during World War I as they fell near Barthelemon, France, while serving with Company E, 16th U.S. Infantry Regiment, 1st Infantry Division. **(1917)**

- 4 Nov The Continental Congress established statutory rations for the Continental Army in an effort to safeguard the health of the troops. Issued uncooked, the rations included one pound of beef, pork, or salted fish per man per day, along with one pound of bread and one quart of beer or cider. Six pounds of hard soap were issued each week to every hundred men for laundry and bathing purposes. (1775)
- Major General Arthur St Clair led 1,400 regulars and volunteers into an ambush laid by 1,000 Miami Indian warriors near the headwaters of the Wabash River, 100 miles north of the later site of Cincinnati, Ohio. Afflicted with rheumatism, asthma, and "colic," St Clair's lack of vigilance led to the loss of 637 killed and 263 wounded in the debacle. Senior Surgeon Richard Allison distinguished himself by helping halt and rally the fleeing troops, while Surgeon's Mate Victor Grasson was killed in action while tending the wounded. (1791)
- North Carolina native Dr Richard Gatling of Indianapolis, Indiana, patented his design for a six-barreled weapon capable of firing 200 rounds per minute. Gatling sincerely believed that the Gatling Gun would make war impossible by making it unthinkable due to the horrific carnage created by such a weapon. (1862)
- 11 Nov World War I ended in an armistice with a total of 53,400 American battle deaths, 63,100 nonbattle deaths, and 204,000 wounded in action out of 4,730,000 service members, of whom 1,390,000 saw action in a combat zone. Medic James Banholzer was the last AMEDD soldier to die in action as he went to the aid of wounded comrades in the 128th Infantry Regiment, 32nd Infantry Division, near Ecurey, France. Banholzer died approximately 2 hours before the armistice took effect at 1100 hours. (1918)
- Mary Mallon, the original "Typhoid Mary," died of pneumonia complicated by chronic nephritis and myocarditis. America's first identified carrier of typhoid fever, she was a cook employed in private homes and at least one hospital. Dubbed "the Ghoul of the Griddle" by newspapers, she once attacked a physician with a meat cleaver when he suggested that her presence in successive households may have been linked to the sudden appearance of the disease among the residents. Ms Mallon, an Irish emigrant instrumental in the deaths of hundreds of people between 1901 and 1915, she was ordered quarantined for life by the New York Department of Public Health. (1938)
- 13 Nov In an effort to determine if any consciousness remained following decapitation, three French physicians attended the guillotine execution of Monsieur Theotime Prunier. Immediately after the blade fell on the condemned man, the trio retrieved his severed head and attempted to elicit some sign of intelligent response by "shouting in his face, sticking in pins, applying ammonia under his nose, silver nitrate, and candle flames to his eyeballs." In response, they could record only that Monsieur Prunier's face "bore a look of astonishment." (1879)
- 14 Nov Captain Robert J. Carrara served as battalion surgeon with the 450 men of the 1st Battalion, 7th U.S. Cavalry, 1st Cavalry Division, as the unit was nearly over-run and

destroyed during fierce fighting with North Vietnamese troops in the Ia Drang Valley, Republic of Viet Nam. Medic Charles Lose used toilet tissue and T-shirts to dress wounds and kept 13 comrade alive during the 2-day action after his medical supplies were depleted. In 53 hours of battle, the Americans suffered 79 killed in action and 121 wounded in action. Enemy losses totaled an estimated 1,850 killed and wounded and six prisoners of war. (1965)

- 21 Nov President John F. Kennedy's last official action prior to his assassination dealt with American military medicine as he dedicated a new building at the U.S. Air Force School of Aerospace Medicine, Brooks AFB, TX. (1963)
- 24 Nov Court astrologers and physicians warned King Charles VIII of France that the imminent conjunction of Jupiter, Mars, and Saturn under the sign of Scorpio meant that the nation was menaced by an epidemic of venereal disease, which had been recently imported from the New World by the returning Spanish sailors of Columbus. (1494)
- 30 Nov Lieutenant General John B. Hood's Confederate Army of Tennessee (27,000 men) launched a frontal attack against a 28,000-man Union force entrenched at Franklin, TN, suffering 6,252 casualties in a futile assault. Hood, who had suffered a crippling wound to one arm at Gettysburg in July 1863, and lost a leg to amputation following a wound received at Chickamauga in September 1863, conducted the entire doomed campaign while under the influence of painkilling opiates. His Army was destroyed 16 days later at the Battle of Nashville. Among the dead at Franklin was MG Patrick R. Cleburne. An Irish-born son of a physician who practiced pharmacy prior to the war, Cleburne was the only pharmacist to reach division and corps command in either Army during the Civil War. (1864)
- 8 Dec Adjutant General's Office Order No. 72 halted the issuance of the daily whiskey ration to American troops. The 0.47-liter liquor ration was ended because it was deemed to exert "a pernicious effect upon their health, morals, and discipline." (1830)
- 10 Dec Treaty of Paris ended the Spanish-American War, which had begun on the preceding 21 April. United States Army losses totaled 369 combat deaths, 2,061 deaths from disease, and 1,594 wounded. (1898)
- 13 Dec The Union Army of the Potomac staged a series of failed frontal assaults against an entrenched Army of Northern Virginia at Fredericksburg, VA, suffering 12,000 casualties in 1 day. Army Medical Director Jonathan Letterman cleared the battlefield of Union wounded within 24 hours. Only 500 of the 11,000 doctors in AMEDD service at that time had received any prewar surgical training. Out of 300 Confederate Army doctors, only 27 were school-trained surgeons. Most military physicians of the day had never even seen a gunshot wound prior to receiving their first battlefield casualty. (1862)
- 17 Dec Several medics were among the approximately 90 American soldiers massacred by German SS troops near Malmedy, Belgium, during the "Battle of the Bulge" in World War II. (1944)

- 18 Dec The Continental Army went into winter quarters at Valley Forge, PA. By spring, disease, malnutrition, and exposure had generated 2,000 deaths among the 12,000 troops. (1777)
- 19 Dec General Dwight D. Eisenhower contributed to the 5th U.S. Army's preventive medicine disease control effort by fatally shooting a rat which he found in his quarters' lavatory in an Italian villa. (1943)
- 20 Dec Ambrose Pare died in Paris at the age of 80. Called the "Father of Surgery," he was credited with restoring surgery to the level of a professional specialty among physicians after a long period during which it was regarded as a crude and unsavory trade. An authority on the treatment of gunshot wounds, Pare instituted such reforms as abandoning cauterization in favor of ligatures, while discarding the practice of pouring boiling oil into a wound as a means of cleaning it. He also outraged many of his fellow physicians by criticizing the use of such standard contemporary medications as "ground unicorn horn" and "mummy dust." (1590)
- 21 Dec Surgeon Robert Lipton, a Scot, performed the first European surgical operation conducted under an anesthetic, a leg amputation which required only 2 1/2 minutes "from first blood to bucket." (1846)
- 23 Dec General Hideki Tojo, Japanese Prime Minister and minister of war during 1941-45, went to the gallows after his conviction for war crimes. Prior to his execution, the defeated warlord received dental treatment from CPT E.J. Mallory, DC, who engraved the Morse Code symbols for "Remember Pearl Harbor" on one of the doomed militarist's fillings. (1945)
- 25 Dec Birth date of Irish immigrant Jenny Rodgers. Lack of thorough physical examinations allowed her to assume the name of Albert Cashier and enlist in the 95th Illinois Infantry in August 1862. She served for 3 years during the Civil War, seeing action at Vicksburg, Atlanta, Nashville, and Mobile before being discharged in August 1865. Still posing as a man, she returned to Illinois and escaped detection until injured in a traffic accident in 1911. In 1913, she was committed to the state mental hospital, where she died after being forced to wear a dress for the first time in 50 years. (1844)

†Dr Austerman is the Historian, U.S. Army Medical Department Center and School, Fort Sam Houston, TX.

AUTHOR INDEX - 1999

A

Addison, William R. MAJ, MS	Apr-Jun	p 14
Applewhite, Larry MAJ, MS	Apr-Jun	p 7
Austerman, Wayne R. PhD	Jan-Mar	p 47
	Apr-Jun	p 43
	Jul-Sep	p 40
	Oct-Dec	p 36

B

Bean, James R. CPT, MS	Oct-Dec	p 20
Benge, Timothy SGT	Jul-Sep	p 29
Berg, Benjamin LTC, MC	Jan-Mar	p 17
Berigan, Timothy R. MAJ, MC	Apr-Jun	p 23 p 25
Billman, Michael A. COL (Ret), DC	Jul-Sep	p 34
Breault, Lawrence G. LTC, DC	Apr-Jun	p 39
	Jul-Sep	p 34

C

Campbell, Kyle D. MAJ, MS	Apr-Jun	p 27
	Jul-Sep	p 13
	Oct-Dec	p 26
Campbell, Spencer J. MAJ, MS	Jan-Mar	p 5
Carroll, Terry LTC, MS	Jul-Sep	p 25
Cook, Jerry A. MAJ, MS	Apr-Jun	p 27
	Jul-Sep	p 13

Coppola, M. Nicholas MAJ, MS	Jul-Sep	p 17
Cuenin, Michael F. LTC, DC	Jul-Sep	p 34
<u>D</u>		
Deagle, Edwin A. CPT, MS	Apr-Jun	p 22
De Lorenzo, Robert A. MAJ, MC	Jul-Sep	p 9
	Oct-Dec	p 2
<u>E</u>		
Elliott, Charles W. Mr	Jul-Sep	p 2
Evans, Barry W. Maj, MSC (USAF)	Apr-Jun	p 27
<u>F</u>		
Fowler, Edward B. LTC, DC	Jul-Sep	p 34
Frank, Kirk J. MAJ, MS	Apr-Jun	p 35
Freid, Ronald L. CPT, MC	Jul-Sep	p 9
Freund, Beau J. LTC, MS	Jul-Sep	p 20
<u>G</u>		
Goodman, Robert L. MAJ, MS	Apr-Jun	p 27
	Jul-Sep	p 13
<u>H</u>		
Hart, John C. SFC	Apr-Jun	p 39
Holcomb, Barbara R. MAJ, AN	Oct-Dec	p 33
Horne, Dan Mr	Jan-Mar	p 17
Houser, Joseph B. MAJ, MS	Apr-Jun	p 39
<u>I</u>		
Irwin, Christopher J. LT, MSC (USN)	Apr-Jun	p 27

J

Jones, Charlotte K. COL, DC Apr-Jun p 39

K

Kim, Myung H. COL, MS Jul-Sep p 13

L

Lamiell, James M. COL, MC Jan-Mar p 45

Liewehr, Frederick R. LTC, DC Jan-Mar p 2

Lynch, Larry C. LTC, MS Jul-Sep p 2

M

Marshall, Stephanie A. COL, AN Jan-Mar p 17

McMurry, Pat LTC, MS Jul-Sep p 2

Meyer, Robert D. COL, DC Oct-Dec p 29

Millar, William H. MAJ, MS Apr-Jun p 27

Miller, Charles F. COL, MC Jan-Mar p 17

Moore, Edward A. (Drew) MAJ, DC Apr-Jun p 39

N

Nam, Theodore S. LTC, MC Jan-Mar p 38

P

Peake, James B. MG, MC
Jan-Mar p 1
Apr-Jun p 1
Jul-Sep p 1
Oct-Dec p 1

Perkins, James CPT, MS Apr-Jun p 2

Perry, Mark MAJ, MS Apr-Jun p 27

Pincus, Simon H. LTC, MC	Oct-Dec	p 12
Pincus, Simon H. MAJ, MC	Jan-Mar	p 38
Pinto, Robert C. Mr	Jan-Mar	p 5

R

Richardson, Thomas D. COL, DC	Oct-Dec	p 17
Rimmer, Jeffery F. CPT, MS	Apr-Jun	p 27
Ritzer, Darren R. CPT, MS	Jan-Mar	p 5

S

Sammarco, Domenic A. LTC, MS	Oct-Dec	p 7
Sotomayor, Raul SFC	Jul-Sep	p 20
Still, Ron Mr	Jan-Mar	p 46

T

Thompson III, Jack F. CPT, DC	Oct-Dec	p 29
Turner, Betty E. LTC, MS	Jan-Mar	p 20

V

Valentine, John N. SGT	Jan-Mar	p 5
Vangeertruyden, Peter 2LT, MS	Apr-Jun	p 2
Villarin, Albert R. CPT, MC	Jul-Sep	p 9

W

Whelen, A. Christian MAJ, MS	Jul-Sep	p 20
Wymes, Michael R. COL, MC	Oct-Dec	p 12

Z

Zierhoffer, Diane MAJ, MS	Apr-Jun	p 7
---------------------------	---------	-----

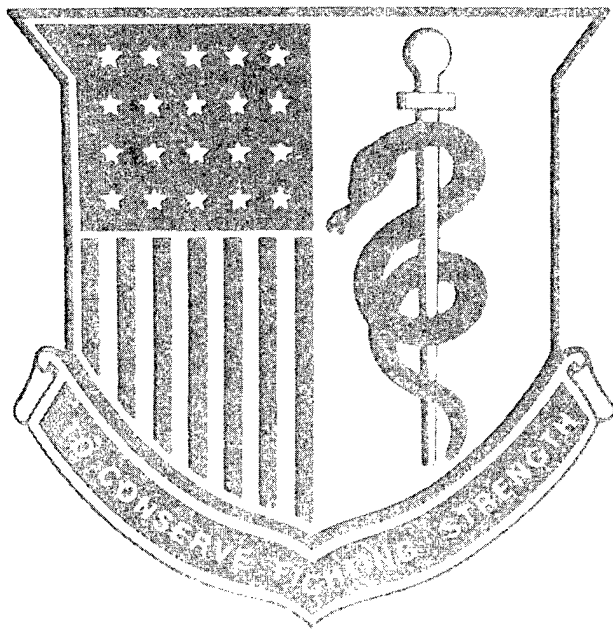

SUBJECT INDEX - 1999

A

"...Above and Beyond the Call of Duty"	Jan-Mar	p 46
Acute Myocardial Infarction	Jul-Sep	p 29
AMEDD Dateline	Jan-Mar	p 47
	Apr-Jun	p 43
	Jul-Sep	p 40
	Oct-Dec	p 36
Aeromedical Crash Rates	Jul-Sep	p 9
Army Medical Department Regiment...helping maintain the AMEDD tradition of caring	Apr-Jun	p 14
Asia-Pacific Military Medicine Conference: AMEDD Support of the National Strategy	Jan-Mar	p 17

B

Book Reviews:		
Sepsis and Multiorgan Failure	Jan-Mar	p 45
Black Hawk Down	Jul-Sep	p 38

C

Case Reports:		
Smokeless Tobacco Cessation Therapy; Naltrexone Related Smoking Cessation	Apr-Jun	p 22
Case Studies in Aviation Medicine: Bosnian Deployment	Oct-Dec	p 20
Combat Stress Control Garrison Mission: A Model for the Future	Oct-Dec	p 12

D

Disease and Nonbattle Injury Forecasting	Jul-Sep	p 2
--	---------	-----

E

Economic Efficiency Factor Applied to U.S. Army DENCOM	Apr-Jun	p 27
Electronic Monitoring of Temperature Sensitive Pharmaceuticals	Apr-Jun	p 35
Evolution of Misbehavior in Insurance and Worker's Compensation	Jul-Sep	p 17
Experiences of a Medical Company Commander in Bosnia	Apr-Jun	p 2

H

Human Dimensions Research During Operation "Joint Guard," Bosnia	Jan-Mar	p 5
---	---------	-----

K

Knowledge Management in the AMEDD	Jan-Mar	p 20
-----------------------------------	---------	------

L

Letterman System for Casualty Treatment and Evacuation	Oct-Dec	p 26
---	---------	------

M

Malaria Surveillance in Operation New Horizon-Peru	Jul-Sep	p 20
Maximizing Medical Evacuation	Jul-Sep	p 25

N

91W: Force XXI Combat Medic	Oct-Dec	p 2
-----------------------------	---------	-----

P

Perspective	Jan-Mar	p 1
	Apr-Jun	p 1
	Jul-Sep	p 1
	Oct-Dec	p 1
Preparing for a Disaster	Oct-Dec	p 7
Providing Echelon II CHS to a Digitized Fourth Brigade	Oct-Dec	p 33
Psychological Aspects of Deployment: The Bosnian Experience	Jan-Mar	p 38

R

Restructuring the Medical Service Corps: The 70Z Proposal	Jul-Sep	p 13
--	---------	------

S

Setting the (Dental) Record Straight	Oct-Dec	p 17
Smile Center: Innovation Increases Patient Access to Care	Apr-Jun	p 39
Stress-Free Endodontics by Case Selection	Jan-Mar	p 2
Surgical Management of Stillman's Clefts	Jul-Sep	p 34

T

Tattoos: Attitudes and Beliefs Among Enlisted Medical Personnel	Apr-Jul	p 7
Treating Rampant Caries: Winning the Battles, Losing the War	Oct-Dec	p 29



The AMEDD Regiment

When medical soldiers pin on the AMEDD Regiment Distinctive Unit Insignia, they make certain commitments:

A commitment to maintaining the standards of excellence set in the past

A commitment to fellow soldiers in providing the best medical care

A commitment to the emerging medical technology

A commitment to the unity that exists between the corps and the Army Medical Department specialties

For additional information concerning membership in the AMEDD Regiment, contact the Regiment at DSN 471-8455, Commercial (210) 221-8455, FAX DSN 471-8697, or Commercial (210) 221-8697.

WRITING AND SUBMITTING ARTICLES FOR THE AMEDD JOURNAL

The AMEDD Journal is published quarterly to provide all members of the Army Medical Department with a medium for the timely dissemination of healthcare, research, personnel, and combat and doctrine development information.

Manuscripts should be submitted with the following guidelines:

- 1. Manuscripts will be reviewed by the Journal staff and, if appropriate, forwarded to the AMEDDC&S activity having subject matter expertise for further assessment.*
- 2. It may be necessary to revise the format of a manuscript in order to conform to established page composition guidelines.*
- 3. Articles should be submitted in disk form (preferably Microsoft Word on 3.5" disk) accompanied by two copies of the manuscript. Journal format requires four double-spaced typewritten pages to complete one page of two-column text. Ideally, manuscripts should be no longer than 20 to 24 pages. Exceptions will be considered on a case-by-case basis.*
- 4. The American Medical Association Manual of Style should be followed in preparation of text and references. Abbreviations should be limited as much as possible. A list identifying abbreviations and acronyms should be included.*
- 5. Photographs submitted with manuscripts can be black and white or color. Color is recommended for best print reproduction quality. Space limitations allow no more than ten photographs per manuscript. Only photographic prints will be accepted for publication. Slides, negatives, or X-ray copies will not be published. Their position within the article should be clearly indicated in the manuscript. To avoid possible confusion, the top of photographs should be marked on the reverse. Photo captions should be taped to the back of photographs or submitted on a separate sheet.*
- 6. A complete list of references used in the text must be provided with the manuscript. This list should include a maximum of 25 individual references. Each should provide the author's last name and initials, title of the article, name of the periodical, volume and page number, year of publication, and address of the publisher.*
- 7. Drugs should be listed by their generic designations. Trade names, enclosed in brackets, can follow.*
- 8. The author's name(s), title, current unit of assignment, PCS date (if applicable), and duty phone number should be included on the title page.*
- 9. Articles should be submitted to: COMMANDER, U.S. ARMY MEDICAL DEPARTMENT CENTER & SCHOOL, ATTN MCCS HSA, 2250 STANLEY ROAD STE 250, FORT SAM HOUSTON TX 78234-6150. DSN 471-6916/7326, Comm (210) 221-6916/7326, FAX DSN 471-8720, Comm (210) 221-8720.*

