

AD \_\_\_\_\_

GRANT NUMBER: DAMD17-98-1-8208

TITLE: Enhancing the anti-tumor activity of breast cancer-specific cytotoxic  
T lymphocytes

PRINCIPAL INVESTIGATOR: Thomas R. Malek, Ph.D.

RECIPIENT ORGANIZATION: University of Miami  
Miami, Florida 33101

REPORT DATE: July 1999

TYPE OF REPORT: Annual

PREPARED FOR: Commander  
U.S. Army Medical Research and Materiel Command  
Fort Detrick, Frederick, Maryland 21702-5012

DISTRIBUTION STATEMENT: Approved for public release;  
distribution unlimited

The views, opinion and/or findings contained in this report are those of the author(s) and should not be construed as an official Department of the Army position, policy or decision unless so designated by other documentation.

20000828 113

Public Reporting burden for this collection of information is estimated to average 1 hour per response, including the time for reviewing instructions, searching existing data sources, gathering and maintaining the data needed, and completing and reviewing the collection of information. Send comment regarding this burden estimate or any other aspect of this collection of information, including suggestions for reducing this burden, to Washington Headquarters Services, Directorate for Information Operations and Reports, 1215 Jefferson Davis Highway, Suite 1204, Arlington, VA 22202-4302, and to the Office of Management and Budget, Paperwork Reduction Project (0704-0188), Washington, DC 20503.

1. AGENCY USE ONLY (Leave Blank)		2. REPORT DATE July 1999	3. REPORT TYPE AND DATES COVERED Annual - 07/01/98 - 06/30/99
4. TITLE AND SUBTITLE Enhancing the anti-tumor activity of breast cancer-specific cytotoxic T lymphocytes		5. FUNDING NUMBERS DAMD17-98-1-8208	
6. AUTHOR(S) Thomas R. Malek, Ph.D.		8. PERFORMING ORGANIZATION REPORT NUMBER	
7. PERFORMING ORGANIZATION NAME(S) AND ADDRESS(ES) University of Miami Miami, Florida 33101		10. SPONSORING / MONITORING AGENCY REPORT NUMBER	
9. SPONSORING / MONITORING AGENCY NAME(S) AND ADDRESS(ES) US Army Medical Research & Materiel Command Fort Detrick Frederick, MD 21702-5012		11. SUPPLEMENTARY NOTES The views, opinions and/or findings contained in this report are those of the author(s) and should not be construed as an official Department of the Army position, policy or decision, unless so designated by other documentation.	
12 a. DISTRIBUTION / AVAILABILITY STATEMENT Approved for public release; distribution unlimited.		12 b. DISTRIBUTION CODE	
13. ABSTRACT (Maximum 200 words) Directing the immune system to attack tumors represents a potential powerful non-toxic approach for the treatment of breast cancer. Our goal is to ultimately engineer the interleukin-2 receptor (IL-2R) in cytotoxic T cells (CTL) to control signal transduction through this receptor and to improve the in vivo efficacy upon adoptive transfer to a tumor-bearing host. To this aim we have prepared a series of chimeric IL-2R constructs and show that signaling of one such pair appears to be induced by a small molecular weight dimerizing drug. We also established a sensitive in vivo animal tumor model system to be used to characterize such "engineered" CTL. The initial studies in this model indicate that unprimed tumor-specific T cells are essentially ignorant of growing tumor in vivo. By contrast, tumor growth is initially inhibited when adoptively transferred to tumor-bearing mice.			
14. SUBJECT TERMS IL-2 receptor; cytotoxic T cells; dimerizer; cytokine		15. NUMBER OF PAGES 24	16. PRICE CODE
17. SECURITY CLASSIFICATION OR REPORT UNCLASSIFIED	18. SECURITY CLASSIFICATION ON THIS PAGE UNCLASSIFIED	19. SECURITY CLASSIFICATION OF ABSTRACT UNCLASSIFIED	20. LIMITATION OF ABSTRACT Unlimited

FOREWORD

Opinions, interpretations, conclusions and recommendations are those of the author and are not necessarily endorsed by the U.S. Army.

TRM

Where copyrighted material is quoted, permission has been obtained to use such material.

TRM

Where material from documents designated for limited distribution is quoted, permission has been obtained to use the material.

TRM

Citations of commercial organizations and trade names in this report do not constitute an official Department of the Army endorsement or approval of the products or services of these organizations.

TRM

In conducting research using animals, the investigator(s) adhered to the "Guide for the Care and Use of Laboratory Animals," prepared by the Committee on Care and Use of Laboratory Animals of the Institute of Laboratory Animal Resources, National Research Council (NIH Publication No. 86-23, Revised 1985).

TRM

For the protection of human subjects, the investigator(s) adhered to policies of applicable Federal Law 45 CFR 46.

TRM

In conducting research utilizing recombinant DNA, the investigator(s) adhered to the NIH Guidelines for Research Involving Recombinant DNA Molecules.

TRM

In the conduct of research involving hazardous organisms, the investigator(s) adhered to the CDC-NIH Guide for Biosafety in Microbiological and Biomedical Laboratories.

## TABLE OF CONTENTS

Front cover .....	1
SF298 .....	2
Foreword .....	3
Table of Contents .....	4
Introduction .....	5
Body .....	7
Conclusions .....	10
References .....	13
Appendix .....	16-24

## Introduction

The interleukin-2 receptor is comprised of 3 subunits, IL-2R $\alpha$ ,  $\beta$ , and  $\gamma$ c. The function of the  $\alpha$  subunit is solely in IL-2 binding while the  $\beta$  and  $\gamma$ c subunits function in binding and signal transduction (reviewed in ref. (1)). Signal transduction by the IL-2 requires receptor dimerization which bring the cytoplasmic domain of IL-2R $\beta$  and  $\gamma$ c in close proximity (2, 3). These cytoplasmic tails do not contain intrinsic kinase activity. Signaling of IL-2R occurs by the association of distinct signal molecules. Some of these have tyrosine kinase activity, which include Jak-1, Jak-3, and p56<sup>lck</sup>. Others, such as STAT3 and 5, function directly as transcription factors that induce IL-2 responsive genes. Their activation requires docking of the STAT to the IL-2R $\beta$  chain, leading to nuclear translocation and signaling. Finally, the adaptor Shc-2 also is recruited to IL-2R $\beta$  cytoplasmic tail, leading to activation of ras/raf/Map kinase pathway and PI-3-kinase. Signal transduction of the IL-2R is induced by cross-phosphorylation of the cytoplasmic tails, allow recruitment of the aforementioned proteins. As Jak-3 is associated with  $\gamma$ c, it is believed that the activity of this tyrosine kinase initiates the signaling cascade. A recent review by (4) summarized current states of IL-2 signaling.

Signal transduction via the IL-2R controls a number of processes in T lymphocytes. Central is the role that IL-2 plays as a T cell growth and survival factor (1). However, persistence growth to IL-2 sensitizes T cell to apoptosis upon stimulation with antigen (5). IL-2 also controls differentiation of T cells and is clearly important for the development of natural killer cells and generation of cytotoxic T lymphocytes (CTL) (1, 6).

Tumor-specific CTL are promising agents to use to eradicate tumor cells in vivo. However,

their efficacy has been limited in part because of their overall poor growth and survival of CTL in vivo after adoptive transfer in a tumor-bearing animal or patient. The growth/survival inducing properties of IL-2/IL-2R represents an attractive target to potentiate CTL in vivo. Administration of IL-2 has been problematic due to its toxicity and short half-life. An alternative approach that we have been exploring is to control IL-2R signaling by synthetic drugs that are capable of inducing dimerization of cytoplasmic tails. This is accomplished by producing chimeric receptors containing signaling domains of receptors of interest and FKBP-binding domains of immunophilin. Drugs such as FK1012, a dimer of FK506, or the synthetic molecule AP1510, have been shown to induce dimerization of a number of signaling proteins (7-9), pro-apoptotic proteins (10-12), or activation of transcription factors (13). The major aim of our proposed work is to apply this technology to the IL-2R and test its efficacy in tumor-specific CTL.

A new approach to study the ability of T cells to respond to tumors has been utilized by several laboratories. This approach is a derivative of one established by Jenkins and colleagues to study immune responses in vivo (14, 15). In essence, mice receive a tumor that is transfected with a model antigen and then T cells specific for that antigen are adoptively transferred into the tumor-bearing mouse in which all the T cells are tumor-specific as they were obtained from an appropriate T cell receptor (TCR) transgenic mouse. The power of this approach is that one can follow the fate, trafficking, proliferation, and effector function of the CTL, as well as monitor how the tumor escaped the T cells. In one study it was shown that T cells initially responded to the tumor, but eventually the tumor anergized the T cells (16). When the T cells are activated, it appears cross-priming in the regional lymph node is critical. However, in a different tumor model the transgenic tumor-specific T cells simply were not activated (17). Thus, the potential fate and functional activity

of tumor-specific CTL are likely to be dependent upon the nature of the tumor and its tumor specific antigens. The use of tumor-specific TCR transgenic T cell provides the most sensitive methodology to assess the interaction of the immune system with the tumor. We have established a similar model system for two reasons. One is to learn the precise duration and effectiveness of adoptive immunotherapy with CTL. The second is to have a good model system to test the chimeric IL-2R once it is successfully prepared and tested in vitro.

### **Body (Results)**

Development of chimeric IL-2R. Using conventional molecular biology techniques, we have prepared and initially tested 14 distinct constructs that encode chimeric IL-2R subunits (Fig. 1). These constructs contain 4 elements. 1) The presence or absence of myristoylation signal that will target the construct to the inner leaflet of the plasma membrane; 2) the IL-2R $\beta$  or  $\gamma$ c cytoplasmic tails; 3) one or more dimerization domains, usually FKBP, and 4) an hemagglutination epitope tag, for detection of the chimeric constructs. Initial efforts focused on development and testing of pCM $\beta$ F2E/pCM $\gamma$ F<sub>2</sub>E or pC $\beta$ F1/pC $\gamma$ F1 pairs. However, these were not functional (see below), and other arrangements of these domains were produced. Each of these chimeric receptors were placed under the control of the CMV promoter, which exhibit high activity in many cell types, including T cells. The vector also contains and SV40 origin of replication, which simplifies initial testing in transient expression assays using COS7 cells.

We confirmed that each construct was appropriately assembled by biochemical analysis of the resulting encoded gene product and in some cases by DNA sequence analysis (data not shown).

Protein analysis was performed by SDS-PAGE of extracts from COS7 cells transfected with each construct. Western blotting with anti-HA antiserum demonstrated the appropriate size product for the IL-2R $\beta$  chimeric constructs and most  $\gamma$ c constructs. Sometime the resolution of the  $\gamma$ c constructs was less than idea. In these cases the presence of  $\gamma$ c cytoplasmic sequences was additionally examined by Western blotting with antiserum to the cytoplasmic tail of  $\gamma$ c.

Each construct was also tested functionally. For this assay, COS7 cells were transfected with either IL-2R $\alpha$ ,  $\beta$ , and  $\gamma$ c or a chimeric  $\beta$  and  $\gamma$ c pair and with Jak-1, Jak-3, and STAT5. Two-three days after the transfection, cells were harvested, and stimulated with either IL-2 or the dimerizer, AP1510 for 15 min. Cell extracts were prepared and analyzed for the presence of phosphorylated STAT5 as an indication of IL-2 and AP1510-induced signaling by Western blotting with an antiserum specific for tyrosine-phosphorylated STAT5. As shown in Fig. 2, cells transfected with pCM $\beta$ F4E/pCM $\gamma$ F4E were functionally active, although this activity was lower than that seen with control IL-2R transfected cells. AP1510 failed to induced phosphorylation of STAT5 in COS7 cells transfected with the other chimeric constructs. All lanes contained similar levels of STAT5 protein as assessed by Western blotting with an antiserum specific to the STAT5 protein that is insensitive to whether or not it is phosphorylated (Fig. 2). Although not shown, initial analysis of the other the constructs so far have failed to detect AP1510 inducible STAT5 activity.

Collectively, these data indicated that the configuration of the cytoplasmic tail and multiple dimerization site are required for functional activity. We were somewhat surprised that pCM $\beta$ F2E/pCM $\gamma$ F2E and pCMF2 $\beta$ E/pCMF28E were not functionally active. This result suggests that the spacial relationships between the FKBP domain are not proper for heterodimerization. On the other hand, the activity exhibited by incorporating 4 FKBP domain is significant and

reproducible in each of the three experiments and will lead us to further explore this technology for receptor dimerization.

In vitro model for T cell anti-tumor reactivity. We have established a TCR transgenic model to assess the efficacy of unprimed and effector CD8 T cells to respond to tumors. The system uses ovalbumin (OVA) as a model tumor antigen and OVA-specific MHC class I-restricted TCR as the tumor-specific T cells. The T cells are derived from a transgenic mouse designated OT-I (18). Initial studies have focused on the weakly immunogenic EL4 cells as our tumor transfected with OVA. These tumor cells are referred to as E.G7 (19).

Initial studies established that OT-I T cells responded to various forms of the OVA, including E.G7 (Fig. 3). However, upon adoptive transfer to tumor bearing mice, the OT-I T cells did not exhibit anti-tumor activity (Fig. 4). Interestingly, there was no indication that the OT-I cells recognized the tumor. The recovery of OT-I cells in the spleen and lymph node was similar from mice with or without tumor (Fig. 5). Furthermore, the OT-I T cells did not undergo cell division in tumor-bearing mice as assessed by adoptive transfer of carboxyfluorescein diacetate succinimidyl ester (CFSE)-treated OT-I T cells (Fig. 6). This compound is readily taken-up into the cytoplasm of cells, but is not released. The resulting intracellular fluorescence linearly diminishes between daughter cells upon cell division (20). Importantly, these T cells readily divided in vivo when encountering antigen in association with a conventional antigen-presenting cell. This result demonstrates that OT-I cells can respond to its cognate antigen in vivo.

It also does not appear that these naive OT-I cells were suppressed or anergized by the E.G7 tumor. The ability of the transgenic T cells to respond to OVA-peptide was similar regardless of

whether they were obtained from a normal or tumor-bearing mouse (Fig. 7). Thus, these data demonstrate that the striking non-responsiveness or ignorance of tumor-specific T cells even when present in an extremely high frequency in tumor-bearing animals. Importantly, if these E.G7-bearing mice received adoptive transferred CTL effector cells that were primed *in vitro* and exhibited high CTL activity, an anti-tumor response was observed (Fig. 8). Eventually, the tumor ultimately overcame this anti-tumor response. These results were recently presented at FASEB meeting in Washington, D.C. As copy of the abstract is included in the Appendix.

## Conclusions

We conclude that the pCM $\beta$ F4E/pCM $\gamma$ F4E chimeric constructs are able to induce IL-2 signal upon dimerization by AP1510. The requirement for 4 FKBP domain to detect an IL-2 signal is either related to the spatial orientation of these FKBP domains or some level of inefficiency in applying this methodology to heterodimerization. Most of the studies to date have primarily induce signaling by homodimerization or multimerization of signaling molecules (8-13). It is now critical to test whether pCM $\beta$ F4E/pCM $\gamma$ F4E chimeric constructs induce a biological signal in T cells. This will be tested by stable transfection of the vectors encoding these constructs into the into IL-2 dependent CTLL cells. We will test whether the dimerizer induces cell proliferation or extends cell survival. Either of these properties may be useful to enhance CTL activity *in vivo*. Based on our unpublished work with CD8/IL-2R chimeric receptor, sometimes such dimerization of IL-2R cytoplasmic domains may only extend cell survival. If this proves successful, we will then transfect OT-I CTL to test the activity of this chimeric receptor *in vitro* and *in vivo*.

It also appears that all of our other chimeric IL-2R are not biologically active. One important limitation of this conclusion is that our assay of IL-2R function in COS7 cells is relatively insensitive and partial signaling may be difficult to detect. Therefore, it is critical to establish a more sensitive assay to evaluate IL-2-induced signaling for the dimerizer. Three approaches are planned. One is to simply assay phosphorylation of the IL-2R $\beta$  chimeric molecule induced in COS7 cells that are transfected with the chimeric constructs and Jak-3. The second is to specifically evaluate STAT5 transcription induction in a semi-quantitative assays using the IL-2-responsive perforin enhancer as a reporter construct. Lastly, we will assess nuclear localization of STAT5 by confocal microscopy in appropriately transfected COS7 cells. The advantage of this approach is that the time of cellular stimulation can be extend with the possibility of nuclear accumulation of the activated STAT protein. For the constructs in hand, we wish to ascertain the requirement for number of FKBP domains, proximity to the inner leaflet of the plasm membrane, or whether a cytoplasmic receptor is active in signaling.

Two major conclusion emerge from our work with the OVA/OT-I tumor model. First, the failure to activated unprimed OT-I T cells by E.G7 indicates that the T cell immune system is functionally blind to a rapidly growing tumor even through there is no real limit on the number of tumor-specific CTL precursors. A similar observation was made with a fibrosarcoma (17). These observations indicate one means by which tumors escape the immune system, i.e. tumor-specific T cells are ignorant of the tumor. The failure to activate unprimed OT-I was very surprising as the E.G7 was very efficient in stimulating OT-I proliferation in culture. Our data suggest that cross-priming of this model tumor antigen did not occur in vivo and that the T cells failed to productively recognize OVA-antigen associated with the tumor.

The second important conclusion is that effector CTL are competent to generation anti-tumor activity. Therefore, if one succeeds in the generation of CTL, an anti-tumor effect can be anticipated. This is a critical observation as it further supports the notion that CTL are potential anti-tumor therapeutic agents. As shown many times before, the CTL did not eradicate the tumor (21). Thus, extending the overall reactivity of these CTL are paramount for application to the clinic. We plan to continue studying anti-tumor activity of CTL effector cells in vivo in our transgenic model. We are especially interested in establishing the life-span and tumor-infiltrating properties of these effector CTL. These studies will allow us to more precisely define how the tumor defeats effector CTL. This information is critical to ultimately assess the effectiveness of our chimeric receptors once they are expressed in tumor-specific CTL.

## References

1. **He, Y.-W., and T. R. Malek.** 1998. The structure and function of  $\gamma$ c-dependent cytokines and receptors: regulation of T lymphocyte development and homeostasis. *Crit. Rev. Immunol.* 18:503.
2. **Nelson, B. H., J. D. Lord, and P. D. Greenberg.** 1994. Cytoplasmic domains of the interleukin-2 receptor  $\beta$  and  $\gamma$  chains mediate the signal for T-cell proliferation. *Nature* 369:333.
3. **Nakamura, Y., S. M. Russell, S. A. Mess, M. Friedmann, M. Erdos, C. Francois, Y. Jacques, S. Adelstein, and W. J. Leonard.** 1994. Heterodimerization of the IL-2 receptor  $\beta$  and  $\gamma$ -chain cytoplasmic domains is required for signaling. *Nature* 369:330.
4. **Nelson, B. H., and D. M. Willerford.** 1998. Biology of the interleukin-2 receptor. *Adv. Immunol.* 70:1.
5. **Lenardo, M. J.** 1991. Interleukin-2 programs  $\alpha\beta$  T lymphocytes for apoptosis. *Nature* 353:858.
6. **Suzuki, H., G. S. Duncan, H. Takimoto, and T. W. Mak.** 1997. Abnormal development of intestinal intraepithelial lymphocytes and peripheral natural killer cells in mice lacking the IL-2 receptor  $\beta$  chain. *J. Exp. Med.* 185:499.
7. **Houlsinger, L. J., D. M. Spencer, D. J. Austin, S. L. Schreiber, and G. R. Crabtree.** 1995. Signal transduction in T lymphocytes using a conditional allele of Sos. *Proc. Natl. Acad. Sci. USA* 92:9810.
8. **Jin, L., H. Asano, and C. C. Blau.** 1998. Stimulating cell proliferation through the

- pharmacologic activation of c-kit. *Blood* 91:890.
9. **Spencer, D. M., T. J. Wandless, S. L. Schreiber, and G. R. Crabtree.** 1993. Controlling signal transduction with synthetic ligands. *Science* 262:1019.
  10. **Amara, J. F., T. Clackson, Rivera, V.M., T. Guo, T. Keenan, S. Natesan, R. Pollock, W. Yang, N. L. Courage, D. A. Holt, and M. Gilman.** 1997. A versatile synthetic dimerizer for the regulation of protein-protein interactions. *Proc. Natl. Acad. Sci. USA* 94:10618.
  11. **Gross, A., J. Jockel, M. C. Wei., and S. J. Korsmeyer.** 1998. Enforced dimerization of Bax results in its translocation, mitochondrial dysfunction, and apoptosis. *EMBO J* 17:3878.
  12. **MacCorkle, R. A., K. W. Freeman, and D. M. Spencer.** 1998. Synthetic activation of caspases: artificial death switches. *Proc. Natl. Acad. Sci. USA* 95:3655.
  13. **Ho, S. N., S. R. Biggar, D. M. Spencer, S. L. Schreiber, and G. R. Crabtree.** 1996. Dimeric ligands define a role for transcriptional activation domains in reinitiation. *Nature* 382:822.
  14. **Kearney, E. R., K. A. Pape, D. Y. Loh, and M. K. Jenkins.** 1994. Visualization of peptide-specific T cell immunity and peripheral tolerance induction in vivo. *Immunity* 1:327.
  15. **Monodino, A., A. Khoruts, and M. K. Jenkins.** 1996. The anatomy of T-cell activation and tolerance. *Proc. Natl. Acad. Sci. USA* 93:2245.
  16. **Staveley-O'Carroll, K., E. Sotomayor, J. Montgomery, I. Borrello, L. Hwang, S. Fein, D. Pardoll, and Levitsky.** 1998. Induction of antigen-specific T cell anergy: An early event in the course of tumor progression. *Proc. Natl. Acad. Sci. USA* 95:1178.
  17. **Ochsenbein, A. F., P. Klenerman, U. Karrer, B. Ludewig, M. Pericin, H. Hengartner, and R. M. Zinkernagel.** 1999. Immune surveillance against a solid tumor fails because of

- immunological ignorance. *Proc. Natl. Acad. Sci. USA* 96:2233.
18. **Hogquist, K. A., S. C. Jameson, W. R. Heath, J. L. Howard, M. J. Bevan, and F. R. Carbone.** 1994. T cell receptor antagonist peptides induce positive selection. *Cell* 76:17.
  19. **Moore, M. W., F. R. Carbone, and M. J. Bevan.** 1988. Introduction of soluble protein into the class I pathway of antigen processing and presentation. *Cell* 54:777.
  20. **Lyons, A., and C. Parish.** 1994. Determination of lymphocyte division by flow cytometry. *J. Immunol. Methods* 171:131.
  21. **Greenberg, P. D.** 1991. Adoptive T cell therapy of tumors: mechanisms operative in the recognition and elimination of tumor cells. *Adv. Immunol.* 49:281.

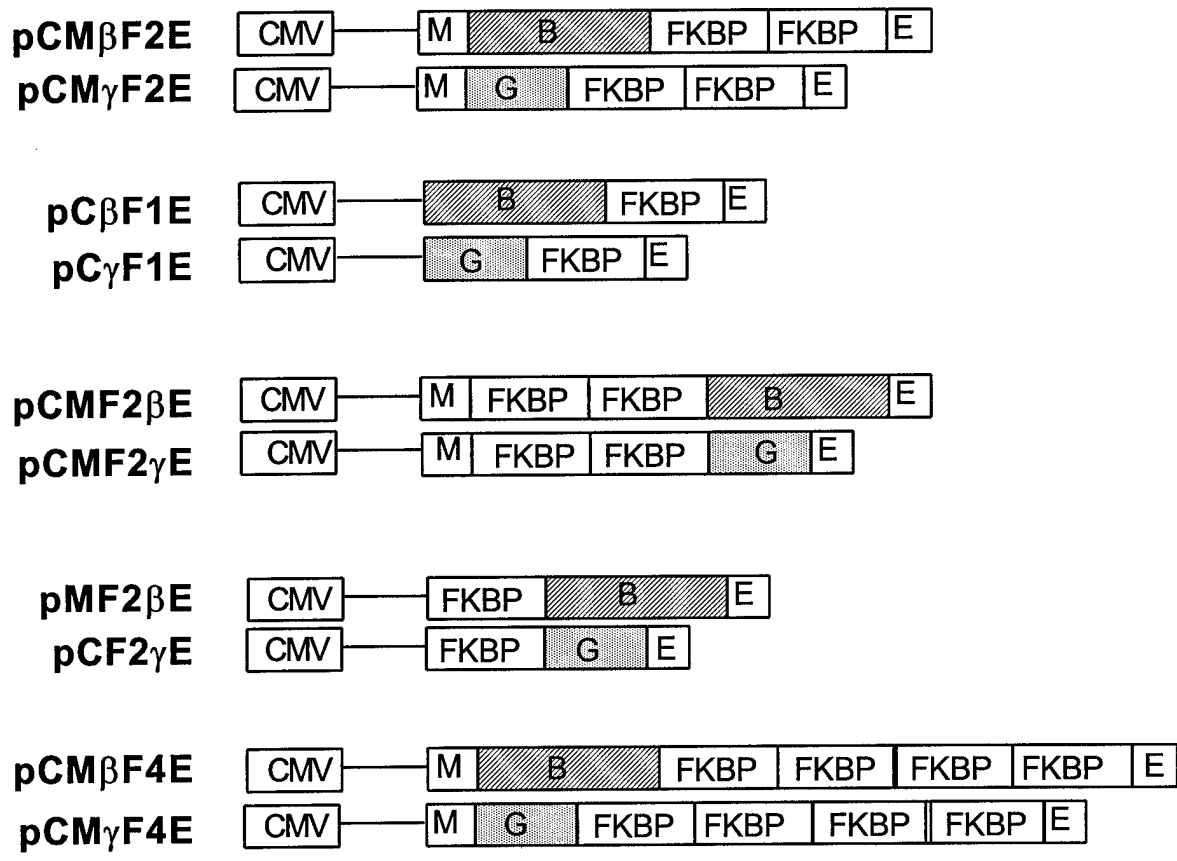

Fig. 1: Constructs of IL-2R drug induced chimeric molecules. The different plasmids were constructed by inserting the PCR fragments of IL-2R $\beta$  and  $\gamma$  cytoplasmic tails with SpeI site at the ends, to the vectors pCMF2E or pCF1E, using the XbaI site (for upstream ) or the SpeI site (for downstream).  
 CMV- CMV promoter, M- Myristoylation signal, FKBP- binding domain for FKBP12 or AP1510, B- cytoplasmic tail of IL-2R Beta, G- cytoplasmic tail of IL-2R Gamma, E- HA epitope.

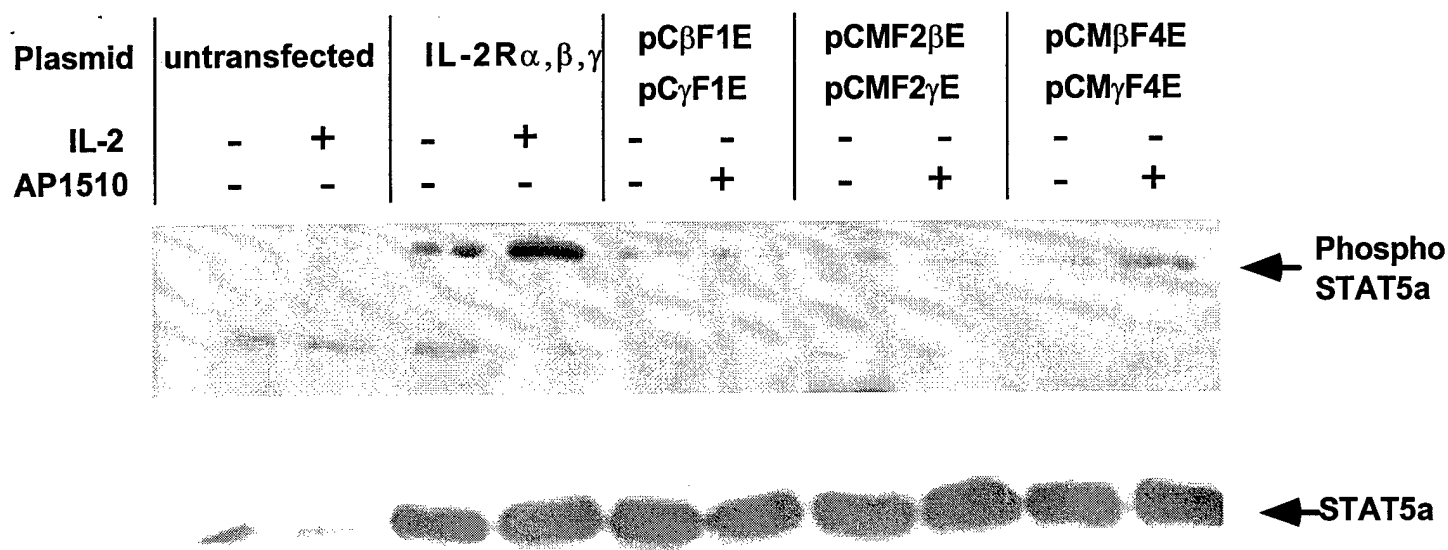

Fig. 2: Ability of the dimerizer to induce phosphorylation of STAT5a in COS-7 cells transfected with chimeric molecules.  $5 \times 10^6$  COS-7 cells were transfected, by electroporation, with  $2\mu\text{g}$  of each plasmid Jak1, Jak3, STAT5a expressing the signaling molecules, and the designated IL-2R subunits or chimeric molecules as the tested molecules. 2 days later the cells were collected and induced for 30 min. in  $37^0\text{c}$  with IL-2 or AP1510. Protein extracts were harvested and immunoprecipitated with anti STAT5. Western blot hybridization was performed with anti phospho-STAT5 followed by stripping and rehybridization with anti STAT5.

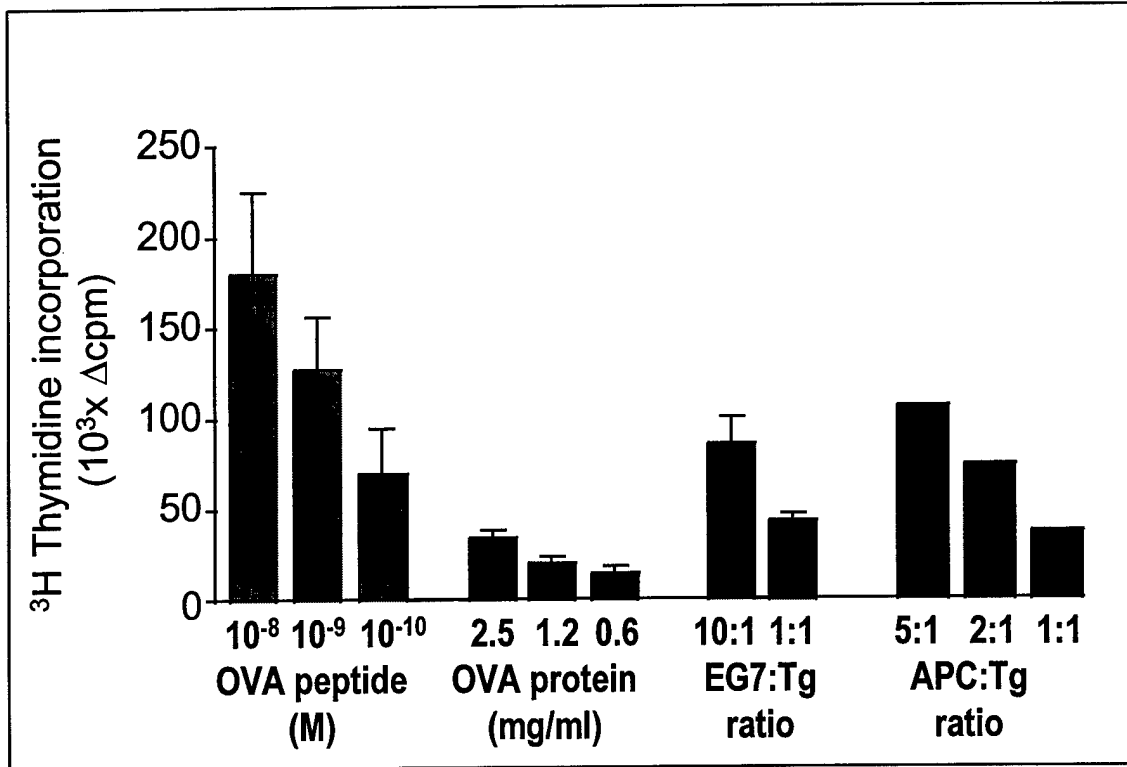

Fig. 3: Specific activation of Tg cells in vitro. The immune activity of the Tg cells was estimated by culturing spleen cells consist of 1% Tg cells for 4 days with several concentrations of the specific OVA peptide (257-264), the OVA protein, and different ratios of irradiated tumor cells and OVA- pulsed APC which are GM-CSF induced bone marrow cells from normal B6 mouse. The proliferation was measured by <sup>3</sup>H Thymidine incorporation for 5 hours. The bars represent the values of CPM after deduction of the values obtained with media only.

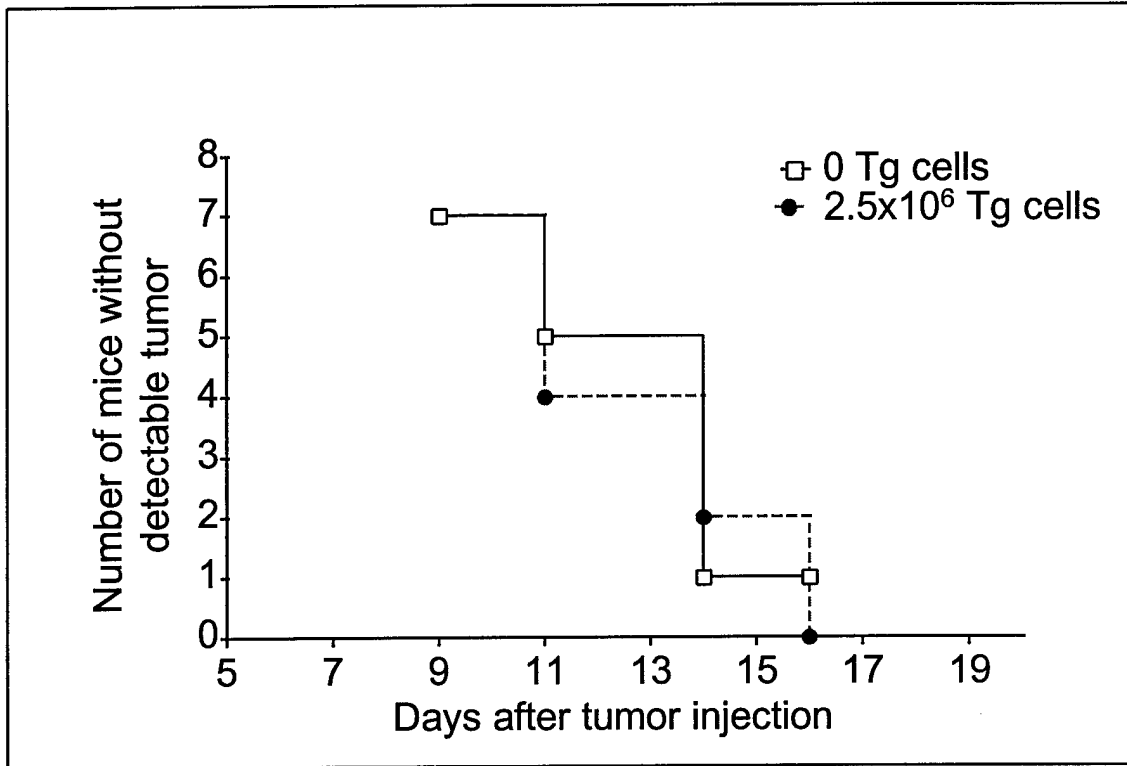

Fig. 4: Naive Tg cells do not affect tumor cell growth. The anti-tumor activity of the Tg cells was determined by injecting all the mice with 1 million tumor cells and 7 days later injecting half of them with 2.5 million naive Tg cells. Detectable tumor was determined as above 0.5 cm<sup>2</sup>.

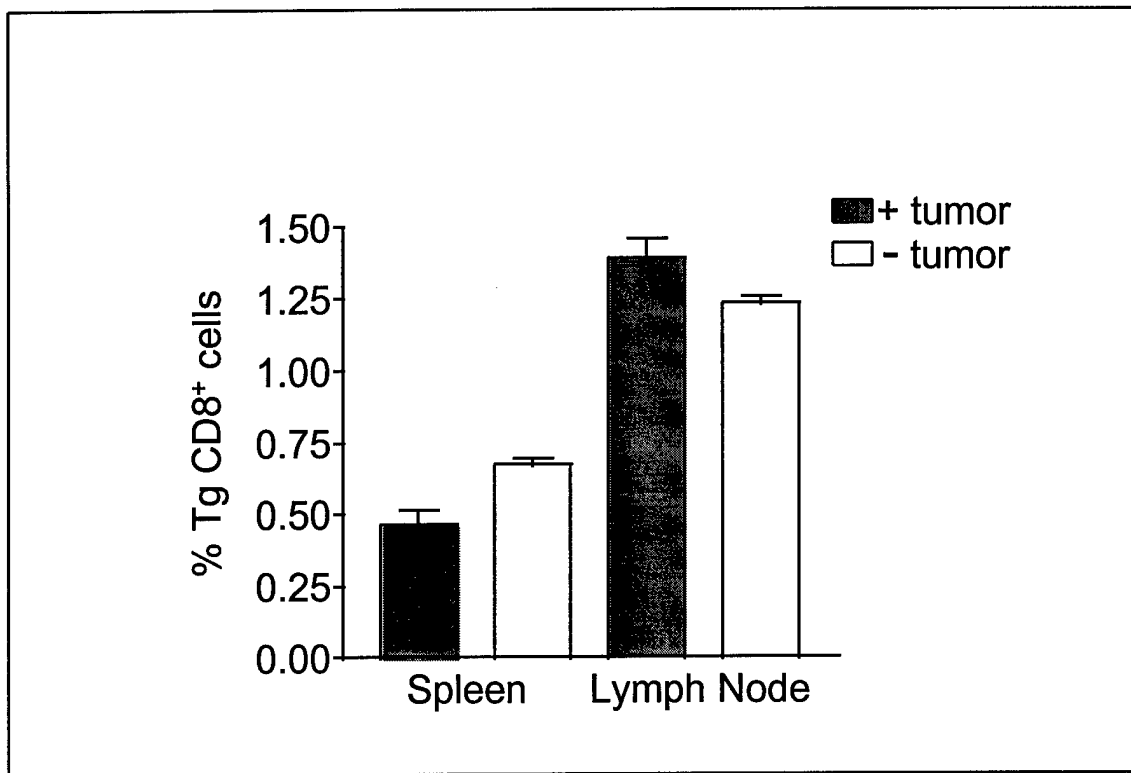

Fig. 5: Transgenic cells do not expand in tumor bearing mice. Expansion of the Tg cells in the tumor presence was determined by injecting half of the mice with 1 million tumor cells S.C. and 7 days later inject all the mice with 4 millions Tg cells I.V. The spleens and the draining lymph nodes were harvested 7 days later and analyzed by FACS. The cells were stained for CD8 and the specific  $V\alpha$  and  $V\beta$  of the OVA-TCR. Normal B6 spleen has 0.2% 3-color positive cells and LN have 0.5% 3-color positive cells.

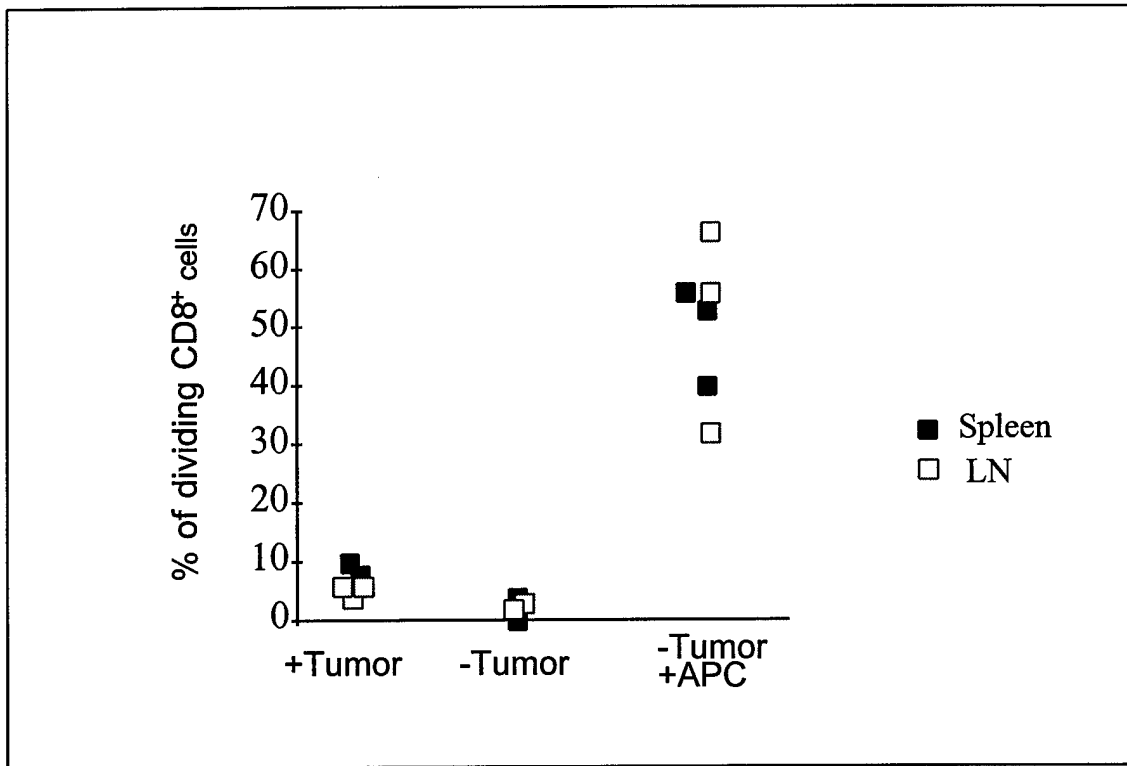

Fig. 6: Tg cells (CFSE) proliferate only in the presence of APC. In order to directly determine if the Tg cells proliferated in tumor bearing mice, the cells were stained with CFSE (Carboxifluorescein diacetate succinimidyl ester) before the injection. This intracellular fluorescent label linearly diminishes between daughter cells upon division. One group of mice was injected with the tumor cells and 5 days later all the mice were injected with 2.5 million Tg cells which were stained with the green dye. APC- Antigen presenting cells, were generated by inducing bone marrow derived cells with GM-CSF and pulsed with the OVA peptide.

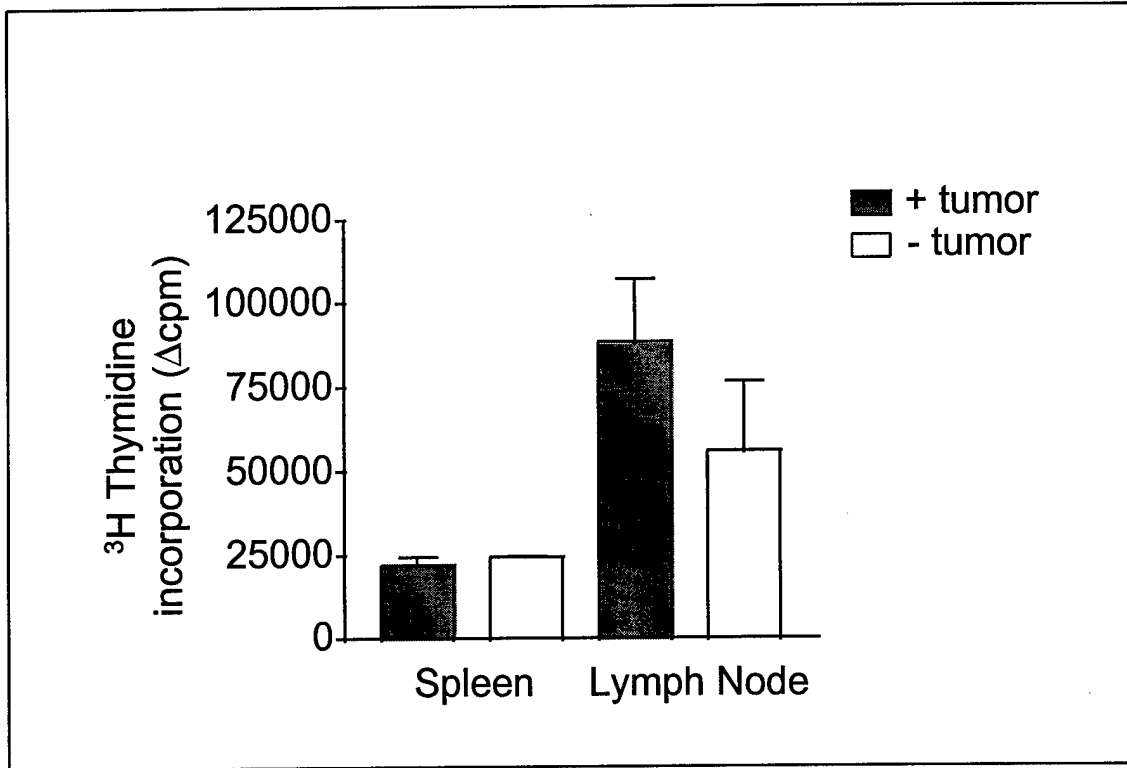

Fig. 7: Transgenic cells are not energized by the tumor. The proliferative response of spleen and LN cells was measured in culture in the presence of OVA peptide for 3 days. The cells were harvested from adoptively transferred mice with or without the tumor. The values of the <sup>3</sup>H Thymidine incorporation in CPM are presented after deducting the values of media only.

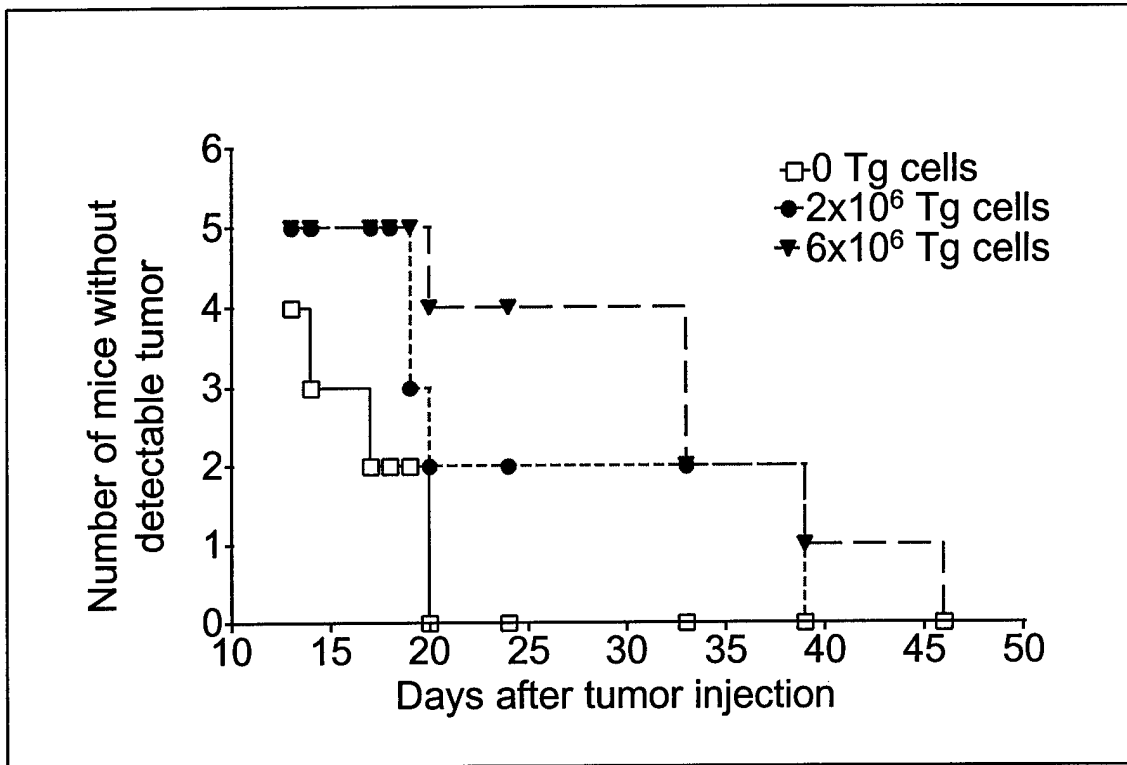

Fig. 8: Effector Tg cells inhibit tumor growth. The capacity of Tg effector T cells to mount an anti-tumor response in vivo was assessed by injecting them into 3 groups of tumor bearing mice. One group did not receive any Tg cells, one received 2 millions and the third received 6 millions of the effector cells. The size of the tumor was recorded then. The effector cells were generated by activating the Tg cells in culture for 5 days with OVA peptide and IL-2/IL-4. These cells exhibit high CTL activity as assessed by specific lysis of EG7 in vitro.

# EXPERIMENTAL BIOLOGY '99

## ABSTRACT FORM

DO NOT FOLD

DO NOT SUBMIT THIS PAPER  
FORM IF YOU HAVE  
SUBMITTED THE SAME  
ABSTRACT ELECTRONICALLY

See page 30 for electronic  
submission instructions.

ABSTRACT AND \$40.00  
PROCESSING FEE MUST BE  
RECEIVED BY MONDAY,  
NOVEMBER 16, 1998.

SEE OVER FOR  
COMPLETE INSTRUCTIONS

**ANTI-TUMOR ACTIVITY OF NAIVE AND ACTIVATED CLASS I-RESTRICTED TUMOR-SPECIFIC TCR-TRANSGENIC T CELLS.**  
Nava Dalyot-Herman and Thomas R. Malek. Department of Microbiology and Immunology, University of Miami School of Medicine, Miami, FL 33101.

The capacity of tumor cells to evade the immune system is still incompletely understood. In the present report we have compared the potential of naive and pre-activated effector CD8<sup>+</sup> T cells to function as anti-tumor T cells using ovalbumin (OVA)-specific T cells from the TCR transgenic (OT-1) mice. Tumors were established by subcutaneous administration of OVA-transfected EL4 (E.G7) cells. Initial studies indicated that OT-1 T cells were efficiently activated to proliferate in vitro by OVA-peptide, OVA-protein, and E.G7. Adoptive transfer of naive OT-1 T cells into tumor bearing syngeneic mice did not inhibit tumor cell growth. The number of OT-1 T cells in the spleen and the lymph nodes of control and tumor-bearing mice was equivalent at several time points after adoptive transfer. Thus, there was no obvious expansion of OT-1 T cells in response to tumor-derived antigens. Furthermore, in vitro challenge of adoptively transferred OT-1 T cells from control and tumor-bearing mice with OVA peptide resulted in essentially equivalent proliferative responses, suggesting that the tumor did not anergize the transgenic T cells. In contrast, adoptive transfer of pre-activated effector OT-1 T cells inhibited tumor growth in a dose-dependent manner. Collectively, these data suggest that the failure of naive OT-1 T cells to elicit an anti-tumor response is due to the inability to activate these cells in vivo. *Supported by DOD.*

**MAILING ADDRESS OF FIRST AUTHOR**  
(Please print in black ink or type. Provide full name rather than initials.)

Phone: (305) 243-5626  
Fax: (305) 243-4623  
Email: NAVADH@INAME.COM

**APS, ASPET, ASIP, ASNS, AAA**

**TOPIC CATEGORY**  
Number Title  
1. \_\_\_\_\_  
2. \_\_\_\_\_

**PRESENTATION PREFERENCE**  
 Oral  Poster  Indifferent

**AAI TOPIC CATEGORY**

See the instructions on pages 13-14.  
Complete boxes below as instructed.

A	B	C	D	E	F	G
01	08	02	21	35	46	54

**MEMBER'S AFFILIATION** (Check one only):  
 APS  ASPET  ASIP  
 ASNS  AAI  AAA  
 Other Official Guest Society \_\_\_\_\_

Submission of signed form indicates acceptance and compliance with "Rules for Submission of Abstracts." (see page 28)

THOMAS R. MALEK  
Member's Name (Print or Type)

TR Malek  
Member's Signature

11/13/98  
Date

(305) 243-5627  
Member's Telephone

(305) 243-4623  
FAX

tmalek@mednet.med.miami.edu  
Email

Signing member, are you willing to chair a session? YES, category 401  
05 cytotoxic

**Author Conflict of Interest**

Check if there is a possible conflict of interest in presenting this information on the part of the author(s) or presenter, so that it may be noted in the Program. See over, regarding possible conflict of interest.

Are you a post-doc? Yes  No

Are you a Graduate Student? Yes  No

See instructions and application forms for student awards on pages 58-74

Final decision regarding presentation format is at the discretion of the programming Society.  
 \*Abstracts and revisions not accompanied by a **check** or a **credit card form** (see inserts) will be returned\*  
 See reverse for complete withdrawal and revision information.