

# **R/V Seward Johnson Cruise 9908: Cruise Report and Preliminary Results**

by T.B. Sanford, M.D. Allison, and J.H. Dunlap

Technical Memorandum

**APL-UW TM 7-00**

August 2000



**Applied Physics Laboratory University of Washington**  
1013 NE 40th Street Seattle, Washington 98105-6698

*Contract NSF OCE 9731543*

DTIC QUALITY INSPECTED 4

20000905 112

*Acknowledgments*

This cruise was funded by the National Science Foundation under Grant No. OCE-9731543. We thank Captain V. Seiler and the crew of R/V *Seward Johnson* and Chip Maxwell and Tim McGovern of the University of Miami's Marine Technology Group for their assistance in the shipboard operations and Mark Prater and Tom Rossby of the University of Rhode Island for their invaluable input during the EM-POGO operations and discussion of the results.

## ABSTRACT

Seawater moving through the Earth's magnetic field generates electric and magnetic fields. This phenomenon is often called motional induction. Previous studies have shown that these motional electric fields can be measured and interpreted in terms of the ocean's velocity field. This report presents results from tests of two instruments that observe motionally induced electric fields in the sea. One, the Towed Transport Meter (TTM), observes three orthogonal components of the ocean's electric field near the surface as a function of distance along track. These data and observations of the motion of the towing ship permit determination of the vertically averaged velocity of the whole water column. The TTM3 was towed in various patterns, such as reciprocal courses and boxes, to determine its performance. The second instrument, EM-POGO, combines electric field observations similar to those of the TTM3 with GPS navigation. This instrument profiles in the vertical and produces a profile of the absolute velocity of the ocean from the surface to the bottom or 200 m, whichever comes first. The resulting profile was compared with the velocity profile from the ship's acoustic Doppler current profiler (ADCP). The field tests were very useful. The TTM3 was found to be difficult to operate reliably, but the EM-POGO produced results in close agreement with those of the ADCP.

## TABLE OF CONTENTS

INTRODUCTION .....	1
CRUISE NARRATIVE .....	2
THE TOWED TRANSPORT METER (TTM3).....	7
Introduction .....	7
TTM3 Signals and Their Interpretation .....	8
Data Interpretation Summary .....	9
Field Observations .....	10
Expected Results .....	10
THE EM-POGO.....	11
Introduction .....	11
The EM-POGO .....	11
Operations .....	13
Results .....	14
APPENDIX A, Towed Transport Meter (TTM3) Deployment Summary and Ship's Tracks .....	A1-A21
APPENDIX B, CTD Deployment Summary and Graphs.....	B1-B8
APPENDIX C, Guildline Autosol Data. ....	C1-C4
APPENDIX D, EM-POGO Deployment Summary. ....	D1-D2
APPENDIX E, Instrument Deployment and Recovery Procedures. ....	E1-E2
APPENDIX F, Schedule of Operations. ....	F1-F4
APPENDIX G, Cruise Personnel. ....	G1

## LIST OF FIGURES

Figure 1.	Track of R/V <i>Seward Johnson</i> Cruise 9908 .....	1
Figure 2.	Diagram of the Towed Transport Meter (TTM3) .....	7
Figure 3.	EM-POGO .....	12
Figure 4.	Location of the EM-POGO test area.....	13
Figure 5.	Comparison between EM-POGO and ADCP .....	14

## INTRODUCTION

On 9–21 July 1999, scientists from the Applied Physics Laboratory at the University of Washington (APL-UW) conducted an oceanographic research cruise aboard the R/V *Seward Johnson* from the Harbor Branch Oceanographic Institution in Fort Pierce, Florida. The cruise track ran from Fort Pierce across the Florida Current, past the southern coasts of Grand Bahama Island and Abaco Island, 125 km east, and back again. The two primary purposes of the cruise were to determine the performance of version 3 of the Towed Transport Meter (TTM3), a self-contained device designed to measure motionally induced electrical currents in the ocean, and conduct sea trials of the EM-POGO, a free-falling velocity profiler. In addition to 16 TTM tows and eight EM-POGO drops, seven conductivity-temperature-depth (CTD) stations were conducted.

This report describes the cruise, the instrument systems used, the location and manner of their deployment, the data processing, and some preliminary results. The complete cruise track is shown in Figure 1. Appendices A–D summarize the TTM3 and CTD drops, the salinity data, and the EM-POGO deployments. Appendix E gives the instrument deployment and recovery procedures, Appendix F presents the original schedule of operations, and Appendix G lists personnel.

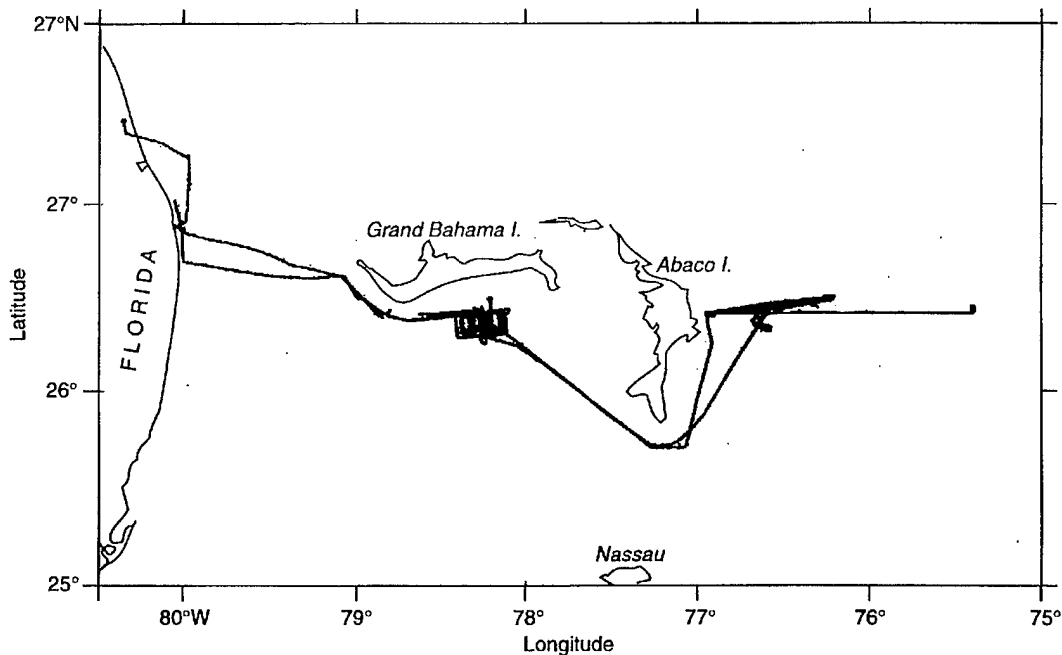

**Figure 1.** Track of R/V *Seward Johnson* Cruise 9908. The cruise started and ended in Ft. Pierce, Florida, with short stops to clear customs in Freeport, Grand Bahama Island.

## CRUISE NARRATIVE

We arrived in Ft. Pierce, Florida, on 6 July and used the next two days to set up the laboratory on the ship and install equipment. We straightened the TTM3 tubing (see Appendix D) using near-boiling water followed by ice water. We left the tubing under low tension on the main deck along the port side. The following narration is taken from the record kept by the Chief Scientist, Tom Sanford of APL-UW. All times are local, EDT.

*9 July 1999*

We left the Harbor Branch Oceanographic Institution (HBOI) at 0630, sailed down the causeway, and exited through the inlet at Ft. Pierce. The first deployment of TTM3, designated TTM41, went into the water at 1330, and the instrument was towed at an average of 12 knots for more than an hour. It appeared that the fish towed very close to the surface at 12 knots, and when we recovered it and examined the data, the pressure data were found to be noisy.

One-hundred meters of 0.250-in. diameter steel cable was added to TTM3 for extra weight, and TTM42 was deployed around 1900 and towed at 8 knots all the way to Freeport on Grand Bahama Island.

*10 July 1999*

We recovered TTM3 at 0438 as we were standing off Freeport and examined the data. The electrode checks during this tow were not working correctly. It appeared that the solenoid was binding and not always making its required stroke. We doubled the time power was being applied to the "unpinch between" solenoid to increase the energy being driven into it.

Having cleared Bahamian customs at 0930, we deployed TTM43 at 1015 south of Freeport for a tow to the next site about 20 n.mi. to the west. We again used 100 m of steel cable, but increased the speed to 10 knots. Applying power to the solenoid for a longer time appeared to solve the sticking problem. A test CTD station to 700 m was successful; the bottles tripped, and the EM-POGO shear pin pressure release worked. EM-POGO2 was then lowered on a line so we could test the ship's ability to find it after release and track it as it ascended and descended. We discovered that the transmitter frequency of 159.48 MHz is not a standard VHF channel, and the bridge could therefore not use its RDF to find the surfaced float. We ended up using our own Yaesu radio and URI's hand-held YAGI antenna to get a range and bearing to the float. A drogue was added to the float to aid in locating it once it surfaced. In addition, we lowered a hydrophone to help the ship's acoustic receiving gear. The hydrophone needed to be underwater because the diurnal thermocline refracted sound rays downward and prevented signals from the surfaced EM-POGO from reaching the ship's hydrophone.

EM-POGO was deployed on a tether a second time, and the results were peculiar enough to indicate the system was not yet ready for full deployment.

We deployed TTM3 on tow 44 at 2030 for a night of towing in closed-box patterns at speeds of 6, 8, and 10 knots, both clockwise and counterclockwise.

*11 July 1999*

We recovered TTM3 after breakfast and noticed that the latex tube connected to the large trailing tube was collapsed somewhat. This might have been the result of pulling the instrument out of the water, but we think the pressure should have equalized as the instrument was carried because the valves, or water switches, continued to operate while it was being carried into the lab.

We spent the rest of the day deploying and recovering various tethered EM-POGO instruments in an attempt to isolate and correct problems that had arisen in the electronics and wiring. By 1600 we had solved all problems except a smaller-than-expected signal on the compass coil, and we decided to make a regular drop.

The first untethered deployment of EM-POGO was EMP006 at 1600. EM-POGO#2 was released from the fantail with 3970 g of weight added, including the pressure release. A surface float with chain and plastic bucket were deployed to mark the point where it sank. It fell at about 0.7 m/s and rose at about 2 m/s. We watched its progress down and up on the ship's acoustic system. We had sent out a Boston Whaler for recovery, and against all odds, in the whole wide ocean, the instrument hit the middle of the underside of the Whaler and then surfaced right behind the motor! There was a small mark on the glass where it hit the boat. The bale on the bucket had broken, so there was no drogue. The radio signal came on 8 minutes after surfacing, and we recovered the float with the Whaler and brought it to the ship. The data looked good.

At about 1930 we put TTM3 in for tow TTM45. Box patterns were run during the night and into the early morning at 8, 10, and 12 knots both clockwise and counterclockwise. We put out an additional 100 m of 0.250-in. cable for the 12-knot run.

*12 July 1999*

We covered TTM3 and disembarked two scientists, Tom Rossby and Mark Prater of URI, to Lucaya at 0800 for their return to Rhode Island. They had been on board for input and discussion during the sea trials of EM-POGO, and we learned from each other.

Almost immediately we returned to the operation area where we had been working, redeployed TTM3, and executed box patterns for the remainder of the day.

Of some concern to us at this time were the large oscillations in the ship's heading, amounting to 15° with a 2.5-minute period. This was more than expected and may add significant noise to the measurements. The captain was consulted, and later we noticed the heading deviation had decreased to 3°.

When tow TTM46 was recovered, we noticed the Spectra towing line was damaged. It looked as if the jacket had twisted, causing ribs to appear on the surface. Having decided it was probably still functional, we dumped the data, confirmed it was OK, and redeployed TTM3 for TTM47. This tow, which continued throughout the night, was a series of reciprocal courses and 90° crosses.

*13 July 1999*

In the morning when TTM47 was recovered and the data examined, we found that there were periods of time when the instrument was being towed very near the surface and times when it was even out of the water. There was sargassum weed on the forward swivel, and something may have been ingested into the water switch and caused it to malfunction during the tow at 10 knots.

With TTM3 in the lab, we deployed EM-POGO#2 on a tether to check the compass coil and the electric field channels. They were fine, so the instrument was dropped freely for EMP008. During the drop, the acoustic tracking gave a picture clear enough for us to follow the descent and to tell us we were 400 m away when it surfaced. It was hard to find, but with P-code GPS, we slowly approached the launch point and found it. The data looked good.

TTM3 was readied for another tow, but malfunctioned on the deck. After it was reset in the lab, it was deployed for TTM48. When we recovered it at 2110, we discovered the electrode ports in the nose had not been uncovered, so the data collected were incomplete.

After TTM3 was aboard, we started for Marsh Harbour on Abaco Island to begin tows on the 26.5°N line. Data from the previous tow had problems that indicated the water switch was not working correctly.

*14 July 1999*

We arrived off Marsh Harbour about 0730, and TTM3 went into the water at 0752 (TTM49). It was towed to the east for 125 km. CTD station 2 was begun after TTM49 was recovered at 1600. It was a deep station with 10 bottles and required 3 hours, much less time than expected. TTM50 was put into the water right after the end of the CTD station, about 1945, for the tow back to Abaco Island.

*15 July 1999*

When the instrument was recovered 10 hours later, some of the longitudinal data, such as velocity from the water switch, and the switch resistance tests didn't look right. We took the instrument apart and found many small globs of seawater in the oil drained from the water switch section. After finding several potential spots where leaks could be

occurring and making a few repairs, we confirmed the circuit board was OK and resealed the whole thing.

However, when the instrument was checked out before the launch it was discovered that the pressure, coil, and maybe other systems were not working properly. On deck while flushing, the water switches failed to operate correctly. We decided to deploy the instrument anyway, hoping that the thermal shock of leaving the lab caused the solenoid to jam. (Estimated lab temperature, 68°F; estimated outside temperature, 98°F; estimated water temperature, 87°F.)

*16 July 1999*

We recovered TTM3 in the morning and discovered that neither of the water switches appeared to have worked. We had to open the instrument again.

While Bob Drever and John Dunlap were working on TTM3 in the laboratory, Dicky Allison asked the captain to conduct tests comparing the power generated by the starboard and port propellers when equal power was applied to both. We were trying to account for the observed oscillations in heading during our deployments. During the tests, the ship appeared to have a weather helm. It appeared to turn into the wind, overshoot it as it turned into the eye of the wind, and then turn back into the wind again. This process may have generated the observed ship's track.

After these tests we returned to near Abaco Island for the start of tow TTM52. During the day's examination of the instrument, we had discovered corrosion of the brass plate for the switch mechanism where tubing was tied to electrode blocks. We concluded this was where water was getting in and decided to tie the tubes twice. During the rebuild, the solenoids kept malfunctioning, but finally, with high hopes, we deployed the instrument around 2100 and towed for 11 hours.

*17 July 1999*

When we recovered the instrument and had it on deck, everything appeared to be working and no water was visible in the oil. Unfortunately the water switches did not work. Back in the laboratory we forced out quite a bit of air from the tubes, enough to have given the tubes a high impedance.

TTM53 began about 1300 and lasted an hour. Analysis of the data suggested the instrument worked partially. The signals were on scale, but the switch resistance checks did not make much sense. It became increasingly obvious that our flushing scheme may not have been up to the job of getting all the air out of the tubes.

We tried some new things for TTM54. To create more of a pressure head for the flushing of the tubes, we placed the bucket of source water 15 feet above the deck. We added a dilute solution of detergent to the water to decrease the surface tension and, we hoped, keep the water from adhering to the walls of the tubes and trapping air. We also kept the water running longer than usual. In the middle of all this, the water stopped

moving through, and we discovered some Agar was plugging the exit of the large tube. We repaired this and lowered the instrument on a line attached to the tail to a depth of 20 m to release bubbles naturally. We then pulled it up and started towing at 6 knots.

*18 July 1999*

We recovered the instrument but found the results from the previous night's tow only marginally better. It appeared that the switches were not electrically open when they were in a pinched state. What we did was apparently an improvement, but it did not cure the problem.

We decided to rebuild the instrument one more time. Clearly, the switches were not working correctly and the Agar was disintegrating, allowing air to accumulate in unwanted places. There was little ship time left and little purpose in staying on the line off Abaco, so we steamed back to the site of our earlier operation, south of Grand Bahama Island.

*19 July 1999*

While we were rebuilding the instrument, it occurred to us that we were going along the wrong path for an instrument intended for use on Volunteer Observing Ships. The self-contained functioning was good, but the complexity and delicacy of the switches and the filling of the tubes were fatal deficiencies. If there was to be a future for TTM, it must be with a pre-filled and rapidly oscillating longitudinal sensor, similar to the spinning nose.

While we were reassembling the instrument and testing a totally new switching mechanism in the lab, the ship put into Freeport for the remainder of the day. The new scheme worked well in the lab and provided a long series of perfect operation. We planned to deploy the rebuilt instrument early in the morning on the last run across the Florida Current into Ft. Pierce.

*20 July 1999*

We left Freeport Harbor at 0100 and finished deploying the instrument for this last tow at 0200. When we awoke the captain told us we were approaching Florida at West Palm Beach, much farther to the south than we had expected. We concluded the Florida Current was but a trickle and Western Europe would be cold later this year. We were a bit concerned about getting to Fort Pierce in time for the appointment with customs/immigration.

We hauled in TTM56 at 0830 and found the data were no good. The arm valve did not function properly and never pinched. We had all thought the new way of powering the solenoids would work and were greatly disappointed.

We cleared U.S. customs that afternoon and disembarked from the ship at Harbor Branch early the following morning.

## THE TOWED TRANSPORT METER (TTM3)

### *Introduction*

The TTM3 (Figure 2) is a simple, self-contained, and rugged system designed to measure motionally induced electric fields in three orthogonal directions. The electric fields or potential differences arise because of the motion of seawater and the measuring instrument through the Earth's magnetic field. The horizontal electric field parallel to the towing vessel's heading is determined from the voltage produced between two silver-silver chloride electrodes connected to the ocean through two saltwater-filled plastic tubes trailed behind the fish. The horizontal and vertical electric fields perpendicular to the ship's heading are determined from the voltages produced between a set of electrodes on the instrument's spinning nose.

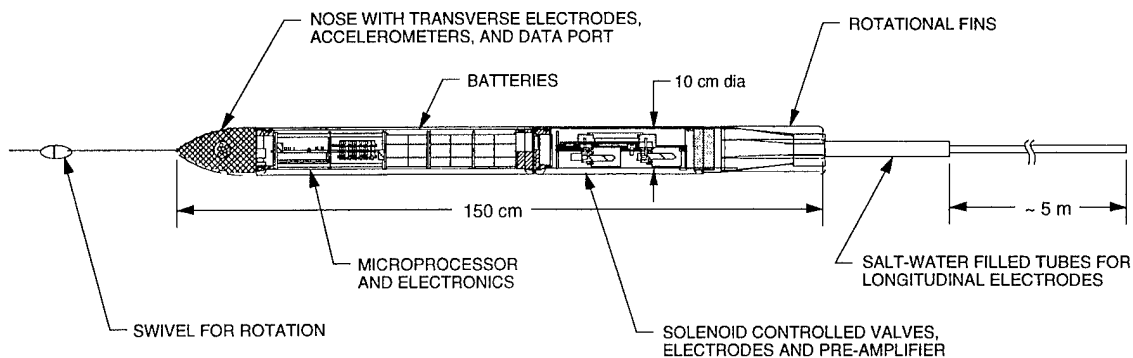

**Figure 2.** Diagram of the Towed Transport Meter (TTM3).

The saltwater-filled tubes are connected to a "water switch" consisting of two electrodes and two solenoid-operated valves that control the electrical continuity of the seawater-filled tubes. Operation of the water switch allows us to separate the ocean electric field from the natural offset or self-potential of the electrodes. Spinning of the main instrument "chops" the other signals, providing AC voltages which can be easily filtered from the DC bias of the electrodes.

TTM3 is a self-contained instrument towed at the end of a nonconducting synthetic line. It contains a microprocessor which determines the three components of the motionally induced electric field and stores time-averaged values. These data are read from the instrument after its recovery at the end of the tow.

Measurements of the ship's speed and heading and wind speed and direction are needed to compensate for signals due to the vessel's motion.

### *TTM3 Signals and Their Interpretation*

As stated earlier, TTM3 consists of pairs of silver-silver chloride electrodes, water switches, and seawater-filled plastic tubes. The electrodes are attached to the voltage-measuring instrumentation. The water switches are solenoid-driven mechanisms which pinch or unpinch rubber tubing. One water switch is connected directly between the two electrodes. The two electrodes are connected to trailing seawater-filled tubes of different lengths. The second water switch is in series with the shorter arm of the two tubes. Each water switch has two states: pinched and unpinched. When the switch is unpinched the electrical resistance across the switches' tubing is comparatively small ( $\sim 1 \text{ k}\Omega$ ), and when it is pinched the electrical resistance should be very large ( $> 1000 \text{ M}\Omega$ ).

The normal state for TTM3 is for the "between" switch to be pinched and the "arm" switch to be unpinched. In this configuration the voltage at the electrodes is the same as the voltage difference between the ends of the tubes. This difference in electrical potential is induced in the tubes and in the ocean by the motion of the tubes and ocean through the vertical component of the Earth's magnetic field. The electrodes contribute a voltage because of small electrochemical differences between them which can amount to several millivolts.

Thus, the input voltage to the measurement system consists of the desired ocean potential gradient and the unwanted electrode self-potential. To determine the self-potential of the electrodes the "between" switch is unpinched and the "arm" switch is pinched. In this state, the only low impedance voltage source is that of the electrode self-potential. The self-potential (e<sub>chk</sub>) is then subtracted from the signal measured earlier (e<sub>sig</sub>) to yield the voltage measured at the ends of the plastic tubes.

As long as the switches work properly and the impedance ratio is a thousand or more between pinched and unpinched states, the water switch scheme works well. However, the performance of a switch can degrade if something prevents a pinched tube from becoming a high impedance or an unpinched tube from becoming a low impedance. The mechanical system can fail to pinch properly or there can be some contamination that allows electrical conduction across a pinched switch or reduces conductance across an unpinched switch. A bit of seaweed will allow conduction where none is wanted, or a bubble of air can prevent conduction where it is desired. Thus, we try to eliminate contamination and bubbles when the TTM3 is prepared for deployment.

The condition of the switches while being towed is determined by periodically applying a 1-Hz square wave of electrical current across each switch. The current comes from a 5-mV source with an output impedance of  $1 \text{ M}\Omega$  which is applied to the electrodes. Thus, if both switches are pinched the voltage between the electrodes should have an amplitude of 5 mV, and if either are unpinched (with a few kilohms of associated tubing) the voltage across the electrodes might be at most a few hundred microvolts. The source current is both positive and negative.

The nomenclature of the TTM3 measurement states is:

$epa0$  = pinch arm, apply neg. test current; between unpinched  
 $epa1$  = pinch arm, apply pos. test current; ; between unpinched  
 $epb0$  = pinch between, apply neg. test current; arm unpinched  
 $epb1$  = pinch between, apply pos. test current; arm unpinched  
 $ept0$  = pinch two, apply negative test current  
 $ept1$  = pinch two, apply positive test current  
 $esig$  = signal when "between" is pinched and arm is unpinched  
 $echk$  = check is with "between" unpinched and arm pinched.

There is another state when the two switches are both unpinched, but this lasts only a fraction of a second and the voltages are not measured. The three-switch resistance-check states last 7 s each, the  $echk$  is 9 s, and  $esig$  lasts 30 s. All of these voltage are measured, averaged, and stored in the TTM3 every 60 s.

The switch resistance measurements provide independent checks on the quality of the  $esig$  measurements. In the following, we assume that  $epa0$  through  $ept1$  have had the electrode self-potential  $echk$  removed. That is, we want to deal only with the *changes* due to the applied electric current. Strictly speaking, in some instances  $esig$  should be the one to be removed, but the ocean signal is generally much less than the electrode self-potential.

The signals for analysis during switch resistance checks are:

$epa0,1$  -  $echk$   
 $epb0,1$  -  $esig$   
 $ept0,1$  -  $echk$

With this adjustment, it is clear that a properly operating TTM3 should exhibit  $ept0$  and  $ept1$  values that are all  $\pm 5$  mV, depending on the sign of the applied current. Absolute voltages less than 5 mV indicate degradation of one or both switches. The values of  $epb0$  and  $epb1$  should be relatively low, mostly less than 0.2 mV. The values of  $epa0$  and  $epa1$  should be even smaller, because there should be low resistance between electrodes.

On recovery of the TTM3, the data are downloaded to the computer. The ocean electric signal is estimated as the difference between consecutive  $esig$  and  $echk$  measurements. The quality of the measurements is revealed by the performance checks on the switch impedances. In principle, corrections could be made to adjust for the reduced impedances. In practice, the situation is changing rapidly, and no attempt has been made to adjust for reduced impedances of switches. When the impedance checks show degradation of the switches, we usually disregard the corresponding  $esig$  -  $echk$  values.

#### *Data Interpretation Summary*

The electric fields measured by the TTM3 are interpreted in terms of the velocities of the ocean and the instrument through the Earth's magnetic field. The observed

signals are a combination of the motion of the TTM3, its orientation, and the motion of the surrounding water. In addition, there are important corrections to account for distortions of the ambient electric currents as they pass around the TTM3's body (and sensors) and for distortions to the local electric field produced as the system passes through the water. The voltage-to-velocity scaling is partially based on theory and ultimately determined by special ocean observations, such as tows in closed boxes.

The instrument basically observes an electric field equivalent to the difference between the instrument's velocity ( $\mathbf{v}$ ) and the vertically averaged ocean velocity ( $\bar{\mathbf{v}}$ ). The vertically-averaged velocity is necessary to determine ocean transport and is a very important but difficult measurement to make by alternative means. So if we can determine the instrument's velocity (the sum of the ship's velocity relative to the water and the water's velocity), we can solve for  $\bar{\mathbf{v}}$ .

### *Field Observations*

The purpose of the at-sea trials was to determine the performance of this new instrument. In particular, we wanted to determine calibrations, such as the distortion of the instrument to ambient electric currents, and to determine bias. By making tows in closed boxes and over reciprocal tracks at various speeds we were able to solve for these unknowns. For example, tows in magnetic E-W and N-S directions produced measurements of predictable values, which we used to evaluate instrument performance. Reciprocal tracks, on average, observed the same ocean signal and provided a means to estimate method bias. Because the ocean conditions changed with time, often during the course of a given box pattern or reciprocal maneuver, it was necessary to conduct many tow patterns. Moreover, because some errors are proportional to tow speed or instrument rotation rate, it was necessary to tow at three or more ship speeds.

Our towed observations were combined with GPS position and GPS heading, ADCP, and wind data to achieve our purposes.

Finally, the Florida Current between Florida and Grand Bahama Island provided a persistent and well-known signal, as did the Deep Western Boundary Current east of Abaco Island. We transited the Florida Current to test the system under high signal conditions, conducted closed box tows in the NW Providence Channel for low signal conditions, and made box and long reciprocal tows off Abaco for combinations of low and high signal conditions.

### *Expected Results*

We expected to determine the calibrations and performance (e.g., noise and errors) of the TTM3 and its ability to determine depth-averaged velocity from a ship underway. We intended to evaluate the feasibility of towing TTM3 from transiting research vessels and ships of opportunity.

## THE EM-POGO

### *Introduction*

The EM-POGO (Figure 3) is free-falling velocity profiler operating on the principles of GPS positioning and motionally induced electric fields. The EM profiling capability determines the vertical profile of the horizontal velocity of the ocean relative to a constant. The constant is determined as the average velocity of the profiler between launch and surfacing as observed by the onboard GPS receiver. The instrument is deployed, freely falls to a preset depth or the bottom, where ballast is released, and rises to the surface for recovery. It emits acoustic signals for tracking underwater and light and RF signals for recovery on the surface.

The oceanic electric field arises from the motion of the instrument and seawater through the Earth's magnetic field. Basically, the EM-POGO observes a velocity profile denoted as  $\mathbf{v}(z) - \bar{\mathbf{v}}$ , where  $\mathbf{v}(z)$  is the horizontal velocity of the ocean at depth  $z$  and  $\bar{\mathbf{v}}$  is the horizontal velocity of the ocean averaged from the surface to the bottom. The GPS data provide an independent value of the horizontal velocity of the ocean averaged over the depth interval of the drop (i.e., from the surface to the depth of weight release).

### *The EM-POGO*

A GPS-POGO parts kit was purchased from Bathysystems, Inc. This included all components of a finished instrument except the mechanical backbone and glass pressure tube. The GPS-POGO has a microcomputer with 16 Kbytes of nonvolatile data storage. It provides temperature and pressure data every 4 s during descent and ascent as well as a GPS position fix just before launch and about 15 GPS fixes after returning to the surface. The latter fixes are used to estimate the surface current so the surfacing position can be extrapolated backwards in time to the surfacing time estimated from the pressure record.

Electric field (EF) and compass coil (CC) data every 0.2 s are provided by a system modified from a prior project. It consists of an Onset Tattletale Model 5 microcomputer (TT5) with 500 Kbytes of RAM for data storage and a circuit board with amplifiers for the above signals. EF data are measured with the electrodes mounted in a PVC collar that has been slipped over the glass tube and taped in place. The coil is mounted to the instrument's backbone. As the instrument rotates in the Earth's magnetic field, the CC provides information on the instrument's direction. Six small fins are hose-clamped to the glass to rotate the EM-POGO as it falls and rises. The EF-CC alignment is measured by sighting through the glass pressure tube and measuring with a tape measure.

Processing of the velocity data requires both the POGO and TT5 data. Several meter blocks of EF and CC data from the TT5 are used in least squares fits to obtain the horizontal electric field referenced to the direction of the Earth's magnetic field. Pressure data from the POGO are used to determine depth and fall rate. Fall rate estimates are required to interpret the EF data to estimate water velocity relative to a constant offset.

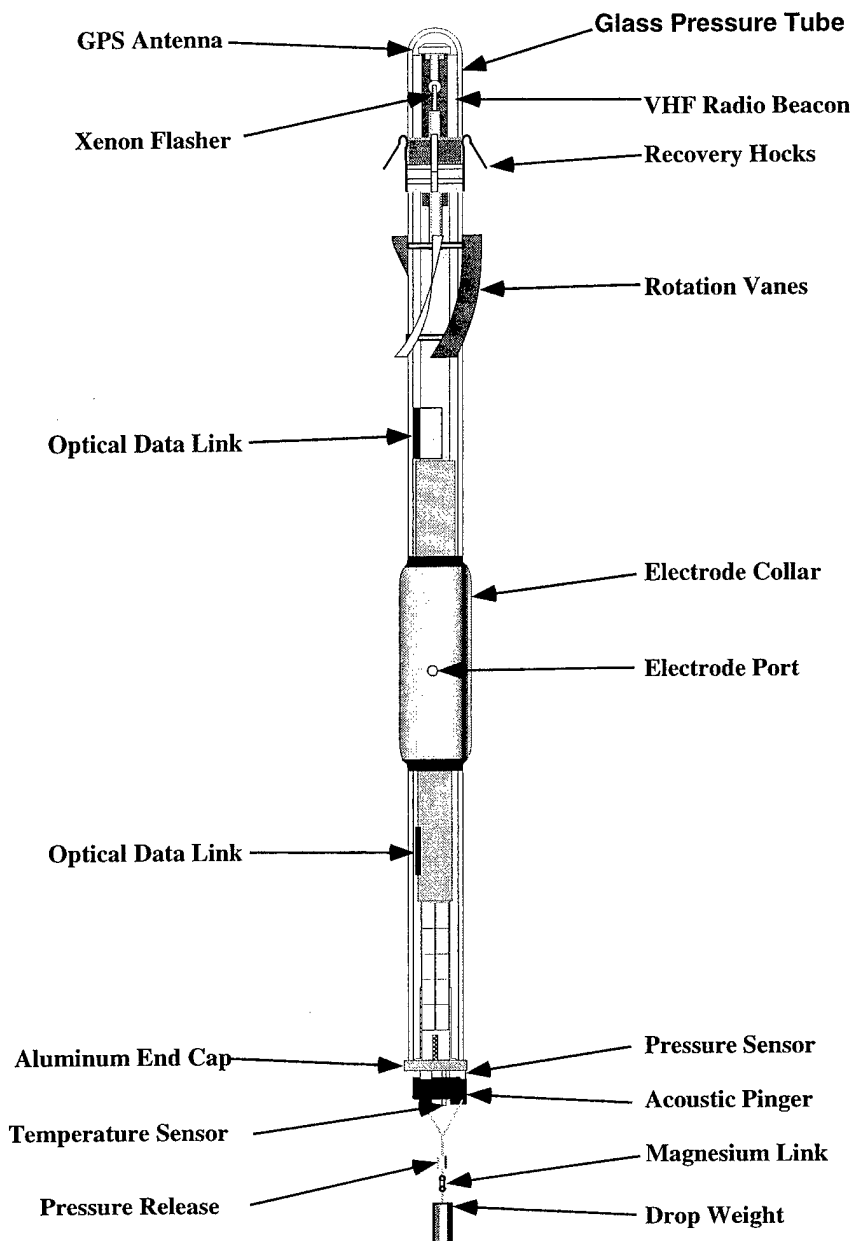
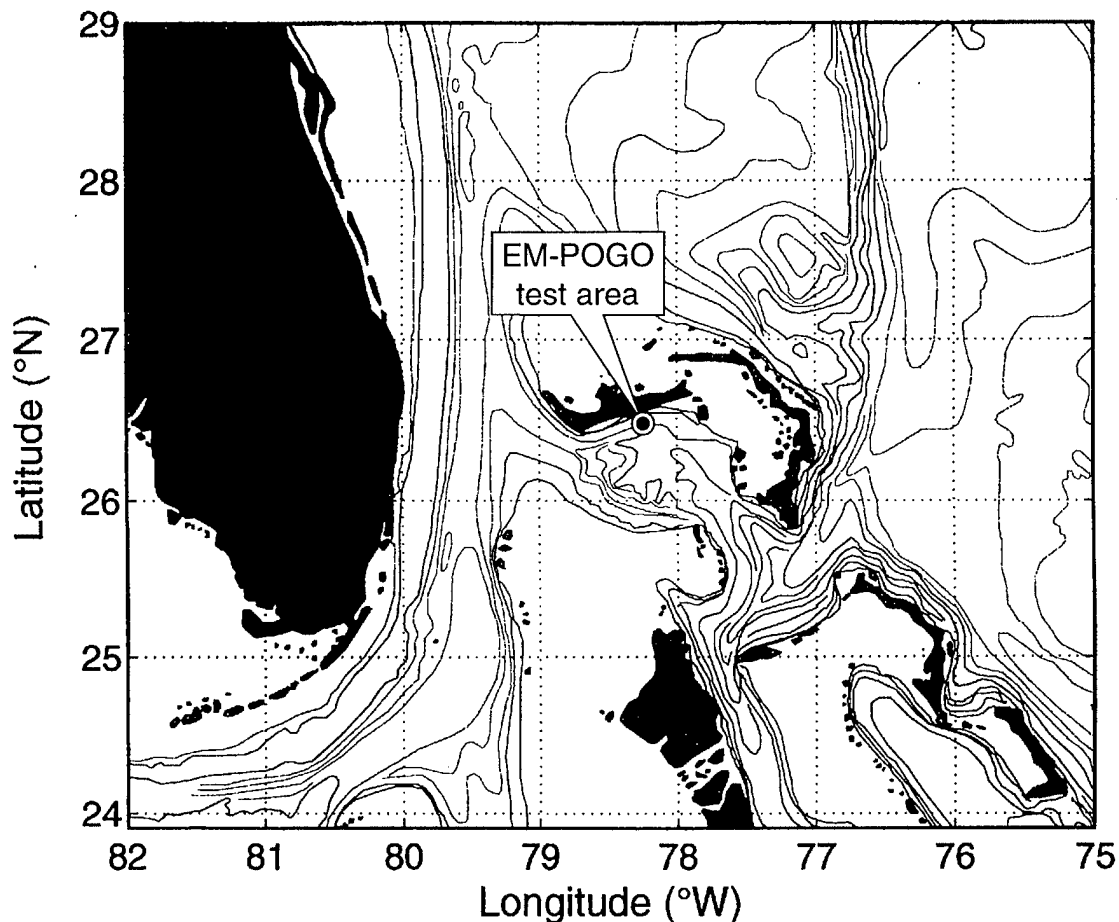

**Figure 3.** EM-POGO. The POGO (produced commercially by Bathysystems, Inc.) was modified to include two silver-silver chloride electrodes on either side of a PVC collar set mid-length on the glass pressure housing of the POGO. Inside the instrument, electric measurement, processing and data storage modules were added. The electrodes are connected to the circuitry in the interior of the POGO through endplate penetrators. A set of pitched vanes causes the instrument to rotate as it falls. The vanes serve two purposes: (1) to provide hydrodynamic stability as the instrument profiles through the water, and (2) to transform the ocean's electromagnetic induction signal to AC, thus allowing its separation from any DC signal from the electrodes. The POGO and EM components are completely isolated physically and electrically, with separate processing, data storage, communication, and power systems.

The constant velocity offset is estimated using the launching position and the surfacing position as provided by the GPS data. The GPS data provide the average velocity while profiling. The offset is determined from the difference between the integral of the EM-derived velocity profile and the average GPS velocity while profiling.

### Operations

The EM-POGO test site is depicted in Figure 4. The instrument was prepared for each drop by setting the mission parameters, using a computer linked to the instrument through LEDs. A mid-depth or bottom release was prepared, and ballast or drop weights were assembled. The seas were very calm, and a simple loop of line was used to lower the instrument to the water surface from the fantail of R/V *Seward Johnson*. One end of the line was released and the float allowed to descend freely. It was then tracked by its acoustical signals while underwater and located visually once on the surface again with the aid of the reflecting tape, flasher, and VHF transmitter. The EM-POGO was brought

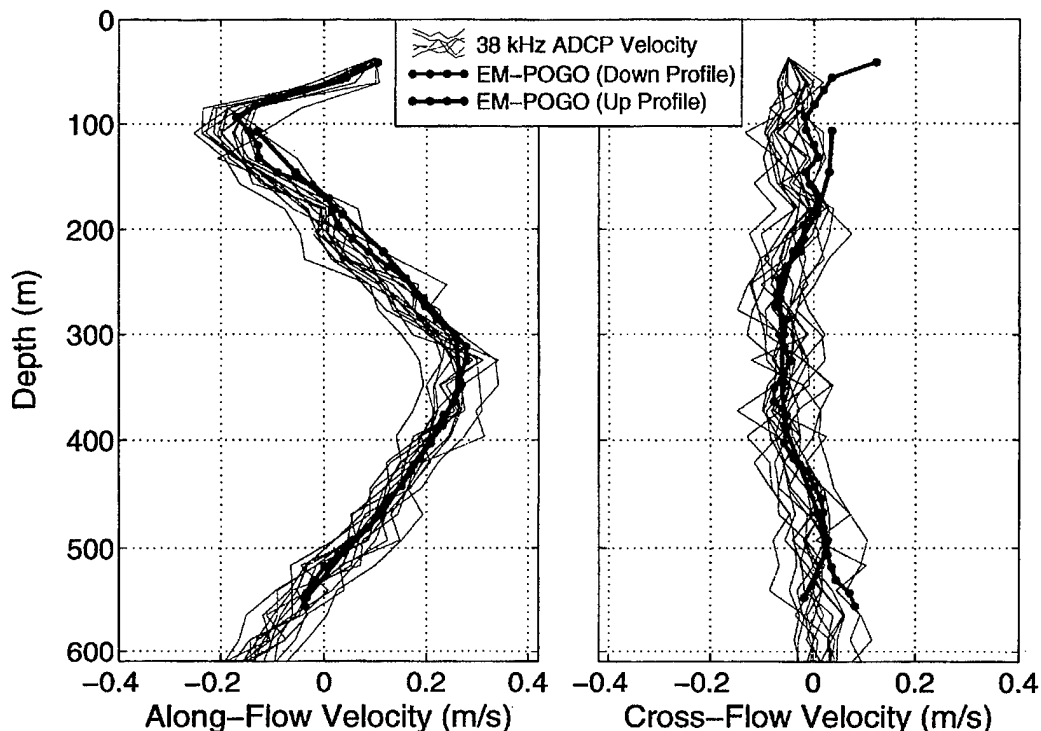

**Figure 4.** Location of the EM-POGO test area in the waters off the southern coast of Grand Bahama Island.

alongside, where a line was placed around the instrument. Hooks on the tube snagged the line, and the instrument was raised on the line over a block on the aft flange of the CTD A-frame. It was carried into the laboratory, where the data were retrieved via the LED data links.

### Results

Our first goal was to establish that the EM-POGO was operating correctly. Then we compared velocity profiles with those from the 38-kHz Acoustic Doppler Current Profiler (ADCP), which produced profiles of horizontal velocity to nearly 800 m every minute. Figure 5 shows the EM-POGO velocity profile along with 15 concurrent ADCP profiles. During this time the ship was stationed at a maximum of 400 m to one side of the instrument drop position to avoid the possibility of the EM-POGO ascending beneath and hitting the ship. The agreement in the large-scale vertical structure of the flow display between the two instrument systems is excellent. However, the EM-POGO data display much less variability (noise?) than the ADCP data, both in time (the EM-POGO's down and up profiles were 20 minutes apart at the surface) and in vertical structure.



**Figure 5.** Comparison between an EM-POGO velocity profile and 15 concurrent ADCP profiles. The EM-POGO profiles represent 20 minutes from surface to surface, and the ADCP profiles represent 15 minutes of elapsed time.

## **APPENDIX A**

*R/V Seward Johnson* Cruise 9908  
Towed Transport Meter Deployment Summary  
and  
Ship's Tracks

**Towed Transport Meter (TTM3) - Bahamas, including Abaco - July 1999**

<i>Tow No.</i>	<i>Date-Time(EST) yymmdd-hhmmss</i>	<i>Latitude North</i>	<i>Longitude West</i>	<i>Comments</i>
41	990709-134600	27 13.2370	79 56.9610	TTM3 deployed.
41	990709-135900	27 12.3394	79 57.0120	Increasing speed to 12 knots.
41	990709-153200	27 0.4120	79 57.7568	TTM3 on deck.
42	990709-190000	26 55.9640	79 57.4775	TTM3 in water.
42	990710-020300	26 42.2924	79 3.7855	Changing course, towing toward Freeport.
42	990710-021037	26 41.6763	79 3.0095	Settled on new course.
42	990710-043800	26 28.8659	78 48.9398	TTM3 on board.
43	990710-102400	26 29.3769	78 45.9332	TTM3 deployed.
43	990710-131100	26 29.9178	78 16.9651	TTM3 on board.
44	990710-202120	26 30.0981	78 14.9033	Begin TTM3 deployment at 8 knots.
44	990710-202810	26 29.3700	78 14.7964	End TTM3 deployment. Box #1 begins, heading S.
44	990710-205220	26 25.6048	78 14.3246	TTM3 box 1 first turn. 10 kt box CW.
44	990710-205520	26 25.3606	78 14.6147	Completed turn. Heading West.
44	990710-212610	26 24.9228	78 20.1422	TTM3 box #1 CW start onto N leg.
44	990710-213140	26 25.5115	78 20.7481	Completed turn. Heading North.
44	990710-220110	26 30.3865	78 21.1438	Start onto E leg.
44	990710-220541	26 30.8175	78 20.6198	Completed turn. Heading East.
44	990710-223625	26 30.0120	78 14.9963	Start TTM44 box#2. 10 knots. CCW.
44	990710-224200	26 29.4066	78 14.3451	Turn completed. Heading South.
44	990710-231210	26 24.5507	78 13.8043	Start turn onto East leg.
44	990710-231905	26 23.8503	78 13.0402	Turn completed. Final heading 083.5.
44	990710-234850	26 24.3011	78 7.8609	Start turn onto N leg.
44	990710-235800	26 25.2641	78 6.8837	Turn completed.
44	990711-002705	26 29.9768	78 7.2398	Start turn onto W leg.
44	990711-003500	26 30.7235	78 8.1106	Completed turn onto West leg.
44	990711-011400	26 30.0190	78 14.9065	Start box#3 CW Begin turn S. Leg 1.
44	990711-012200	26 29.0948	78 15.6564	Complete southward turn. Begin slowing.
44	990711-012520	26 28.6221	78 15.6027	Slowed to 8 knots.
44	990711-015125	26 25.0949	78 15.2503	Start turn to West. Leg 2.
44	990711-015830	26 24.4127	78 15.8607	Completed turn to West.
44	990711-022719	26 23.7921	78 20.1486	Begin turn to the North - Leg 3.
44	990711-023630	26 24.5400	78 21.0533	Settle on course North, (CW box #3).
44	990711-030520	26 28.5290	78 21.5873	Start turn to the East, Leg 4.
44	990711-031250	26 29.2928	78 21.0922	Settle on easterly course.
44	990711-035015	26 30.0216	78 15.5555	Start turn S. Close box #3, Start box #4 CCW.
44	990711-035810	26 29.4179	78 14.7489	Settle onto southerly course. Box #4, CCW. 8 knots.
44	990711-042910	26 25.3558	78 14.4617	Start turn to East.
44	990711-043930	26 24.8383	78 13.2720	Settle onto Easterly course. CCW box #4.
44	990711-050904	26 25.3866	78 9.0518	Starting turn to North.

**Towed Transport Meter (TTM3) - Bahamas, including Abaco – July 1999**

<i>Tow No.</i>	<i>Date-Time(EST) yymmdd-hhmmss</i>	<i>Latitude North</i>	<i>Longitude West</i>	<i>Comments</i>
44	990711-051910	26 26.3222	78 8.2023	Settle onto northerly course. Box #4.
44	990711-062830	26 30.3066	78 13.8345	Start turn S. End Box #4. Begin Box #5 (CW).
44	990711-063630	26 29.4614	78 14.2405	Complete turn South. Slowing to 6 knots.
44	990711-070615	26 26.4488	78 13.9182	Begin turn to W.
44	990711-071545	26 25.8436	78 14.6206	Settle on Westerly course.
44	990711-074509	26 25.5156	78 18.0579	Beginning turn to North.
44	990711-075321	26 26.0375	78 18.7191	Complete turn to North, settle on course.
44	990711-082310	26 29.1927	78 19.1214	Beginning turn to East - box#5 CW.
44	990711-083040	26 29.7857	78 18.7005	Completed turn to East - box #5 CW.
44	990711-091400	26 30.0457	78 13.6114	Box #5 complete. Begin TTM3 haulback.
44	990711-091800	26 30.0622	78 13.1169	TTM3 on deck.
45	990711-192300	26 29.7311	78 14.0801	TTM3 deployment begins.
45	990711-192800	26 29.7322	78 13.5921	TTM3 in water. Steadying up on Magnetic East.
45	990711-193500	26 29.7522	78 12.7492	Start Eastward leg of first box. - CW - 6knots.
45	990711-200305	26 29.9285	78 09.3858	Started turn to South.
45	990711-201021	26 29.4006	78 08.8075	Completed turn to South
45	990711-203958	26 26.2822	78 08.1628	Begin turn to West.
45	990711-204656	26 25.8168	78 08.6094	Completed turn to West.
45	990711-211710	26 25.4464	78 11.9450	Begin turn to North (Box #1 CW).
45	990711-212357	26 25.8223	78 17.4602	Complete turn to North.
45	990711-220043	26 29.5432	78 12.8441	Start turn to West. Complete box #1.
45	990711-221002	26 30.0897	78 13.4948	Begin box #2. CCW. 6knots. Start toward W. Leg 1.
45	990711-223849	26 29.9370	78 16.6469	Begin turn toward South.
45	990711-224750	26 29.3748	78 17.2255	Complete turn toward South. Begin 1/2 hr leg.
45	990711-231813	26 26.3133	78 16.9307	Beginning turn toward East.
45	990711-232617	26 25.7323	78 16.3970	Finished turn toward East. Begin 1/2 hr. leg.
45	990711-235543	26 26.0115	78 13.0348	Begin turn to North
45	990712-000426	26 26.6575	78 12.5947	Complete turn to North. Begin 1/2 hr leg.
45	990712-003422	26 29.6144	78 12.9012	Finish Box #2. Starting turn to East.
45	990712-004051	26 30.0233	78 12.4299	Turn complete, increasing speed. Begin Box #3.
45	990712-004348	26 30.0556	78 11.9841	Up to speed on new heading. (New box = 8 knots).
45	990712-011050	26 30.3839	78 7.8942	Starting turn to South.
45	990712-011720	26 29.8560	78 7.2366	Finished turn. Begin 1/2 hr Southward leg.
45	990712-014900	26 25.5082	78 6.5328	Beginning turn to West.
45	990712-015645	26 24.7698	78 7.2081	Finished turn. Begin 1/2 hr. Westward leg.
45	990712-022636	26 24.2710	78 11.5452	Beginning turn to North.
45	990712-023333	26 24.8216	78 12.2715	Turn complete. Beginning 1/2 hr run to North
45	990712-030900	26 29.4510	78 12.6832	Beginning turn to West. Box #3 completed.

**Towed Transport Meter (TTM3) - Bahamas, including Abaco - July, 1999**

<i>Tow No.</i>	<i>Date-Time(EST) yymmdd-hhmmss</i>	<i>Latitude North</i>	<i>Longitude West</i>	<i>Comments</i>
45	990712-031630	26 30.0059	78 13.3937	Turn completed. Begin Box #4. CCW 8 knots.
45	990712-034630	26 29.5023	78 17.6629	Started turn to South.
45	990712-035220	26 28.9607	78 18.0591	Completed turn to South. Starting 1/2 hr. leg.
45	990712-042154	26 24.9992	78 17.6617	Start turn to East.
45	990712-042635	26 24.7721	78 17.1617	Finish turn to East. Started 1/2 hr leg. (Box #4)
45	990712-045839	26 25.2303	78 12.4916	Begin turn to North.
45	990712-050510	26 25.8865	78 12.0952	Finish turn to North.
45	990712-053529	26 29.7530	78 12.9088	Finished Box #4.
45	990712-054058	26 30.4740	78 13.2777	Add 100m of wire out. Increasing speed to 12 knots.
45	990712-073500	26 30.5922	78 24.1000	TTM3 hauled aboard. Black tape on nose.
46	990712-084400	26 29.8735	78 34.6651	Deploy TTM3.
46	990712-102629	26 29.9500	78 15.0885	Begin Box #1 turn toward South. 10 knots. CW.
46	990712-103230	26 29.4123	78 14.2453	Turn complete. Begin 1/2 hr leg.
46	990712-110204	26 24.3989	78 13.4418	Begin turn to West.
46	990712-110940	26 23.428	78 14.1048	Turn Complete - Begin 1/2 hr. leg toward the West.
46	990712-114000	26 22.9911	78 19.7773	Begin turn toward North.
46	990712-114700	26 23.5871	78 20.7455	Settle onto N. course. Begin 1/2 hr. leg.
46	990712-121600	26 28.4572	78 21.4186	Begin turn to East.
46	990712-122330	26 29.4085	78 20.6191	On course and beginning 1/2 hr. leg to East.
46	990712-125300	26 29.9255	78 14.8682	Begin turn to South. End of Box #1.
46	990712-125800	26 29.6047	78 14.0249	End of turn. Start Box #2. CCW 10 knots 1/2 hr leg.
46	990712-132800	26 24.4643	78 13.2282	Begin turn East.
46	990712-133500	26 23.6294	78 12.4459	On course. towards East. Begin 1/2 hr. leg.
46	990712-140500	26 24.0142	78 06.7884	Begin turn.
46	990712-141300	26 24.8125	78 05.7507	On course - toward North. Begin 1/2 hr. leg.
46	990712-144200	26 29.6154	78 06.0652	Begin turn towards the West.
46	990712-145100	26 30.472	78 7.1040	Turn complete. Begin 1/2 hr leg to West.
46	990712-153200	26 30.0054	78 14.5612	Begin turn South, ending Box #2.
46	990712-153944	26 29.2607	78 15.4425	Slow to 8 knots. - heading S. Begin Box #3. CCW.
46	990712-160930	26 25.0939	78 14.8106	Begin turn to West.
46	990712-161646	26 24.4658	78 15.5124	Turn complete. Begin 1/2 hr leg.
46	990712-164640	26 23.8706	78 20.1076	Begin turn to North.
46	990712-165741	26 24.2137	78 21.4323	Accomplished turn to North. Begin 1/2 hr. leg.
46	990712-172711	26 28.3969	78 21.6977	Begin turn to East.
46	990712-173224	26 28.8681	78 21.1185	Finish turn. begin 1/2 hr. leg to East.
46	990712-180316	26 29.4778	78 16.1497	Start turn to South - Finish Box #3.
46	990712-181400	26 29.0622	78 14.7170	Steady on S. course. Begin box #4. CCW.
46	990712-184506	26 24.7728	78 13.9770	Start turn to East.
46	990712-185227	26 24.4113	78 12.9918	Steady on course to East. Begin 1/2 hr. leg.
46	990712-192627	26 24.9796	78 7.6960	Begin turn to North.

**Towed Transport Meter (TTM3) - Bahamas, including Abaco - July, 1999**

<i>Tow No.</i>	<i>Date-Time(EST) yymmdd-hhmmss</i>	<i>Latitude North</i>	<i>Longitude West</i>	<i>Comments</i>
46	990712-193139	26 25.6032	78 7.4732	Steady on course - continue 1/2 hr. North
46	990712-200213	26 29.7941	78 7.9450	Start turn to West.
46	990712-200944	26 30.2131	78 8.7700	Completed turn to West. Continuing 1/2 hr .
46	990712-204500	26 29.6485	78 13.7253	TTM3 commencing haulback at 6 knots.
46	990712-211140	26 29.2829	78 16.8254	TTM3 back in the lab.
47	990712-221000	26 29.5744	78 14.8974	TTM3 deployed (200 m of wire out) 12 kt. box (#5)
47	990712-224106	26 23.6350	78 14.1085	Beginning turn to East
47	990712-224840	26 22.8295	78 12.9664	Settled onto Easterly direction - 1/2 hr leg.
47	990712-231900	26 23.5292	78 6.4189	Start turn to North.
47	990712-232600	26 24.4811	78 05.6175	Complete turn N. Continue for 1/2 hr.
47	990712-235540	26 30.2002	78 6.2944	Begin turn to West.
47	990713-000523	26 31.4041	78 7.5911	Complete turn to West - 1/2 hr. on this heading.
47	990713-003421	26 30.6849	78 13.7246	Finished Box #5. Starting turn to South.
47	990713-004337	26 29.5066	78 14.8863	Start Box #6. CCW. Steady on southerly course.
47	990713-011143	26 24.0161	78 14.3188	Starting the turn to the West.
47	990713-011943	26 22.9036	78 15.3457	Settled onto Westerly course. - 1/2 hr leg.
47	990713-014914	26 22.2500	78 21.8901	Begin turn to North.
47	990713-015543	26 23.0169	78 22.7454	Settled on course North. 1/2 hr. leg.
47	990713-022519	26 28.7854	78 23.4118	Begin turn to East.
47	990713-023222	26 29.7088	78 22.4211	On course for 1/2 hr. Easterly leg to close Box #6.
47	990713-030607	26 29.9991	78 14.7733	Closed Box #6. Continuing this course for 30 min.
47	990713-033520	26 30.5553	78 8.2835	Beginning to turn around for reciprocal #1
47	990713-041000	26 30.6347	78 7.3854	Back on reciprocal course, and slowing down.
47	990713-041400	26 30.6161	78 7.8643	Slowed to 8 knots. and brought in 100m of wire.
47	990713-051448	26 29.7683	78 16.2754	Beginning the turn to SE - Reciprocal #1 complete.
47	990713-052510	26 28.7751	78 16.0750	Complete the turn - heading SE.
47	990713-060047	26 26.0719	78 11.7894	Starting turning to North to start reciprocal #2.
47	990713-060850	26 26.5499	78 11.1768	Finished the turn - Now North for 1 hr.
47	990713-070800	26 33.9055	78 11.8047	Started the turn to run reciprocal course South.
47	990713-073720	26 33.8351	78 11.7088	Completed turn. Started S on reciprocal #2 Leg 2.
47	990713-083221	26 26.4688	78 11.1346	Start the turn. End reciprocal #2.
47	990713-084200	26 26.3327	78 12.1081	Turn to NW is complete.
47	990713-091520	26 28.8782	78 16.0851	Begin turn to start third reciprocal.
47	990713-092629	26 29.8045	78 15.9542	Turn complete. Speed 10 knots. Start Reciprocal #3.
47	990713-101105	26 30.6125	78 7.5011	Begin turn.
47	990713-105120	26 30.6513	78 8.0809	Turn complete - second leg of Reciprocal #3.
47	990713-115621	26 29.6802	78 18.6723	TTM3 haulback begins.
47	990713-120020	26 29.8283	78 18.8595	TTM3 back on board.
48	990713-163000	26 30.2082	78 14.9743	TTM3 deployment begins.
48	990713-163700	26 29.5306	78 14.9625	TTM3 deployment ends - 200m wire behind ship.

**Towed Transport Meter (TTM3) - Bahamas, including Abaco - July, 1999**

<i>Tow No.</i>	<i>Date-Time(EST) yymmdd-hhmmss</i>	<i>Latitude North</i>	<i>Longitude West</i>	<i>Comments</i>
48	990713-164000	26 29.003	78 14.8693	Start first leg of first cross - 1/2 hr. run South.
48	990713-171026	26 23.9715	78 13.9428	Start diagonal NW.
48	990713-171354	26 23.8762	78 14.2927	Complete diagonal NW.
48	990713-173159	26 25.5633	78 17.1270	Begin turn to cross first leg.
48	990713-173500	26 25.8245	78 16.9125	Steady on course to East to cross.
48	990713-180600	26 26.4608	78 11.1444	Turning South.
48	990713-180800	26 26.2454	78 10.9538	Slowing to 8 knots -- Starting next cross (#2).
48	990713-183742	26 22.1254	78 10.3993	Making turn to NE.
48	990713-184209	26 22.3718	78 9.8737	Finished turn to NE.
48	990713-190137	26 24.3756	78 8.4742	Begin turn to make cross to West.
48	990713-190600	26 24.6316	78 8.8054	Finished turn -- starting straight run to West.
43	990713-193740	26 24.2024	78 13.0050	Completed cross -- beginning turn to South.
48	990713-193910	26 23.7782	78 13.1666	Completed turn to South, decreasing speed to 6 knots.
48	990713-200819	26 20.7796	78 13.0130	Started turn to NE.
48	990713-203939	26 22.1590	78 14.736	On run to East -- 1/2 hour.
48	990713-211000	26 22.0732	78 11.3883	TTM3 Haulback begins.
48	990713-212000	26 21.9032	78 10.5964	TTM3 on deck. - black rubber tape on nose.
49	990714-075200	26 30.1337	76 55.8747	Deployed TTM3.
49	990714-160000	26 29.9955	76 24.7070	Recovered TTM3.
50	990714-193820	26 30.0118	75 25.0019	TTM3 deployment begins.
50	990714-194450	26 30.0450	75 25.6741	TTM3 deployment finished.
50	990715-035140	26 29.9550	76 53.4345	Started turn (cotter pin turn).
50	990715-040830	26 30.1128	76 56.2279	Passing over waypoint -- starting East.
50	990715-042240	26 29.9910	76 53.9150	Straight line going East.
50	990715-072500	26 30.0084	76 22.6228	Haulback begins.
50	990715-073200	26 30.0033	76 22.0437	Haulback completed.
51	990715-223644	26 29.9564	76 51.7327	TTM3 deployment begins.
51	990715-224410	26 29.9250	76 50.9227	Deployment complete - towing East.
51	990716-011900	26 32.8385	76 22.9370	Commencing cotter pin turn.
51	990716-014000	26 32.8456	76 22.9165	Turn complete. Heading West now.
51	990716-040200	26 30.1218	76 50.1583	Turning again in order to go East.
51	990716-042638	26 30.0005	76 50.0964	Turn accomplished.
51	990716-065300	26 32.8904	76 22.3944	Change direction. Now turning to go back West.
51	990716-071300	26 32.9487	76 22.9684	Finished turn to West and at waypoint now.
51	990716-074700	26 32.3060	76 28.9755	Recovered TTM3. Oil contaminated with water.
52	990716-234110	26 31.0798	76 43.1700	Deployment begins.
52	990716-235048	26 30.9720	76 44.3500	Deployment complete.
52	990717-004500	26 30.1845	76 54.5342	Begin turn to East.
52	990717-010400	26 29.7170	76 54.8710	Finish turn to East - 3 1/2 hrs on new heading.
52	990717-043030	26 34.3784	76 16.6161	Beginning turn to go back along track.

**Towed Transport Meter (TTM3) - Bahamas, including Abaco - July, 1999**

<i>Tow No.</i>	<i>Date-Time(EST) yymmdd-hhmmss</i>	<i>Latitude North</i>	<i>Longitude West</i>	<i>Comments</i>
52	990717-052300	26 34.3525	76 16.2823	Finally completed turn!
52	990717-090200	26 29.7285	76 56.0905	TTM recovered.
53	990717-130000	26 30.0177	76 56.0656	Deployment begins.
53	990717-130600	26 30.0217	76 55.9645	TTM3 in water. Now towing West.
53	990717-142300	26 31.4554	76 42.8907	TTM back on board. Tow complete.
54	990717-152600	26 30.0534	76 54.8977	TTM3 in water again.
54	990717-154300	26 30.1916	76 54.8033	Deployment complete.
54	990717-191250	26 34.6811	76 15.8492	TTM3 on board.
55	990717-205000	26 34.7918	76 12.2924	TTM3 dangling over stern, flushing under pressure.
55	990717-215150	26 35.0645	76 12.4149	Deployment on wire begins.
55	990717-215830	26 34.6680	76 11.9769	Deployment on wire complete.
55	990718-041840	26 29.9179	76 54.5716	Turning around.
55	990718-044800	26 30.04645	76 52.3876	Back on track going the other direction.
55	990718-075000	26 33.0836	76 33.1501	TTM3 brought aboard.
56	990720-014000	26 32.1097	78 51.9648	TTM3 deployment begins. Dangling over stern.
56	990720-015600	26 32.5538	78 52.2269	TTM3 deployment complete.
56	990720-032728	26 42.0424	79 2.1550	Turning onto Magnetic West
56	990720-033433	26 42.3141	79 3.3596	Settled on course Magnetic West.
56	990720-082500	26 47.2000	79 58.0000	TTM3 on board.

TTM41 09-Jul-1999 17:46:01 to 09-Jul-1999 19:22:25 UTC

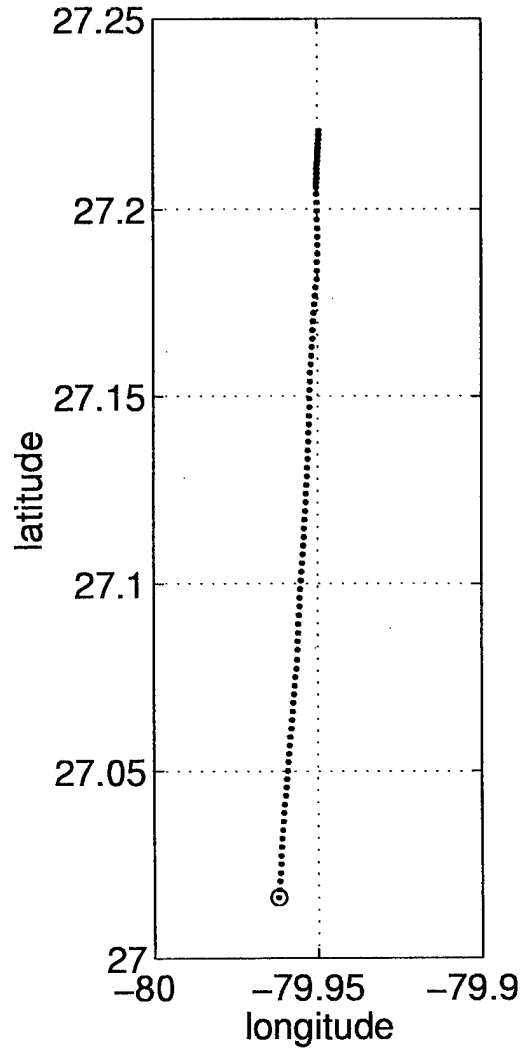

TTM42 09-Jul-1999 23:00:01 to 10-Jul-1999 08:37:49 UTC

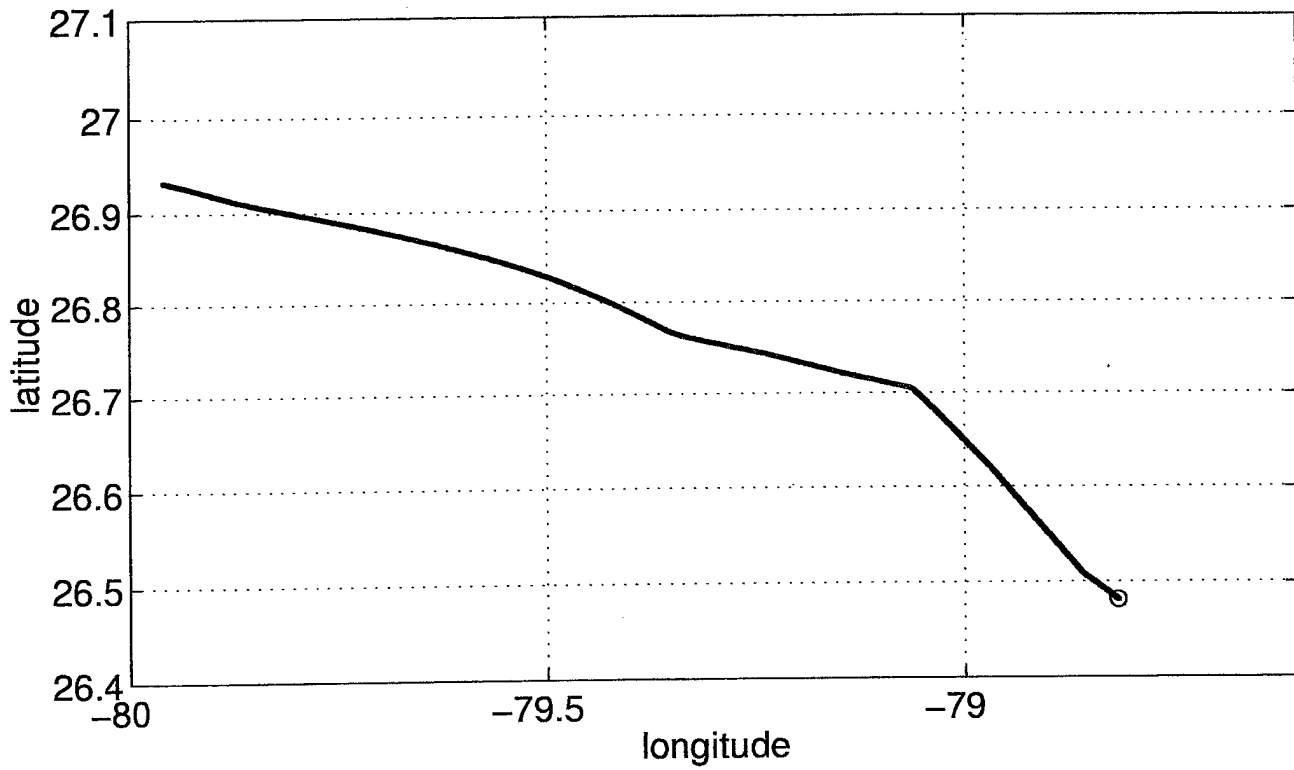

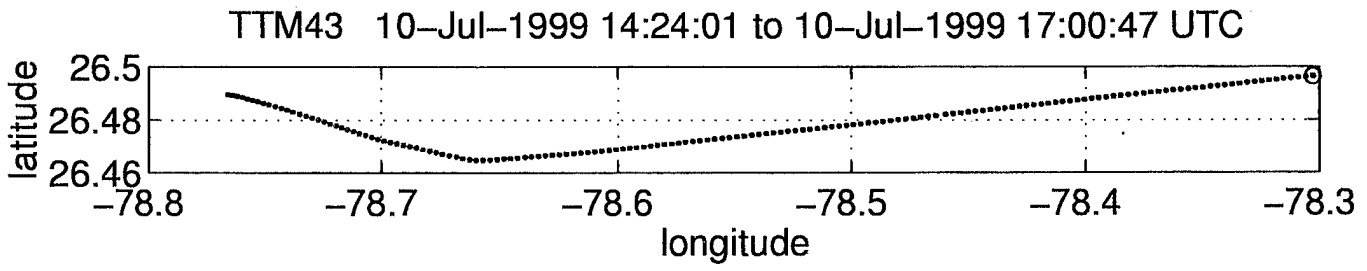



TTM45 11-Jul-1999 23:23:01 to 12-Jul-1999 11:34:44 UTC

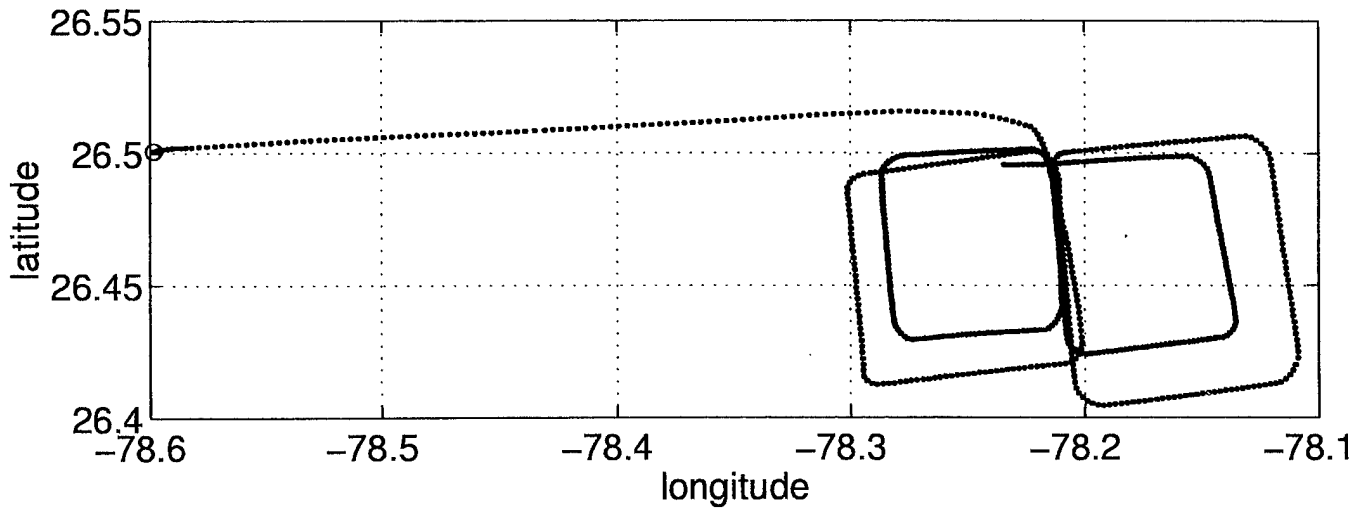

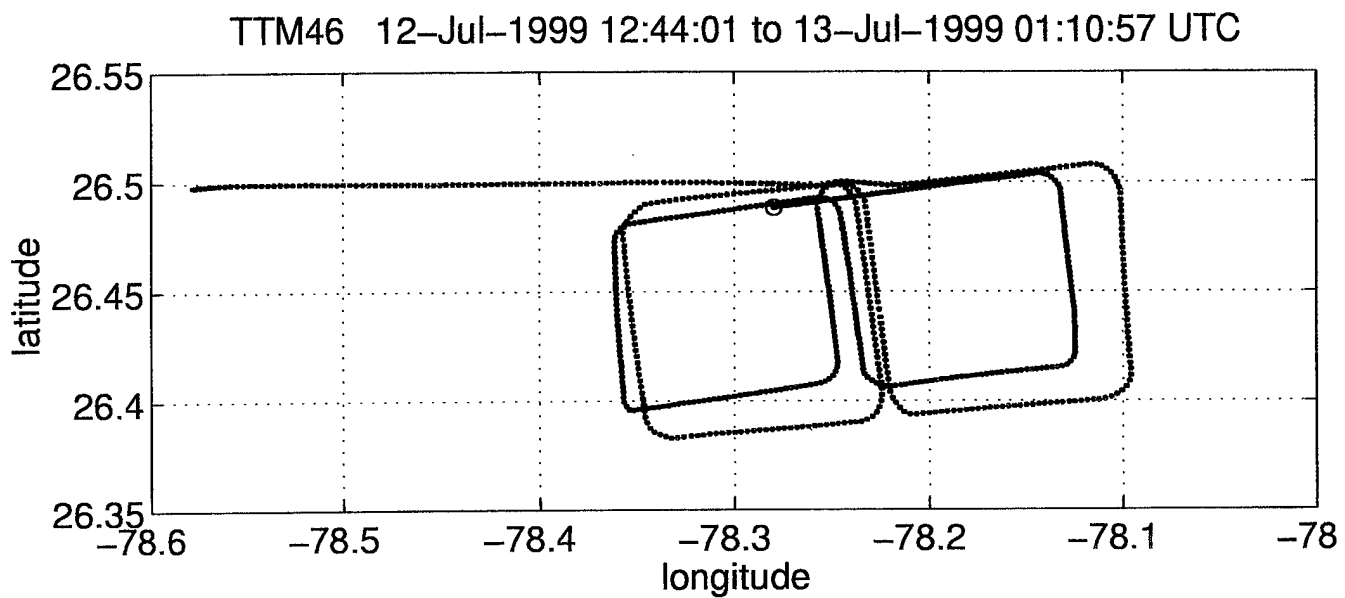

TTM47 13-Jul-1999 02:10:00 to 13-Jul-1999 15:55:56 UTC

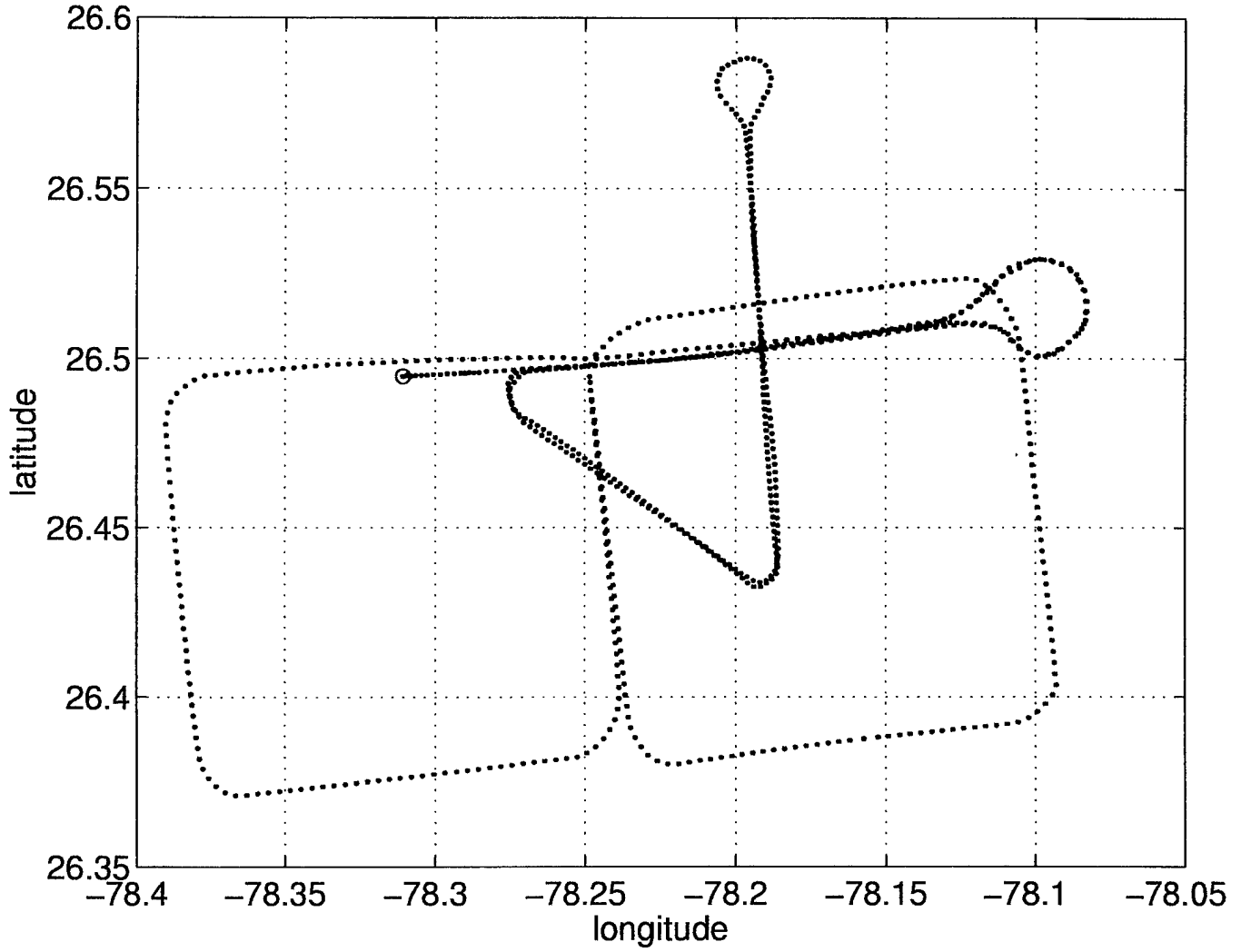



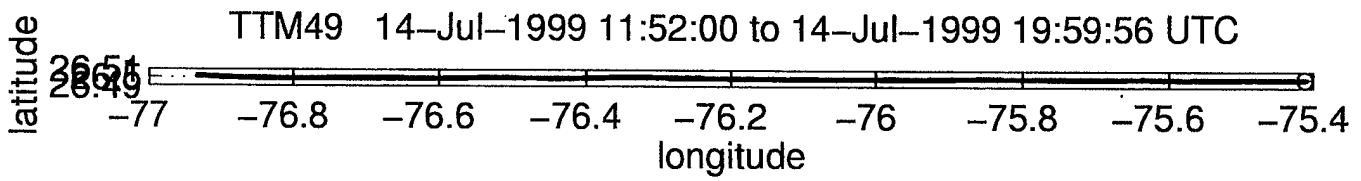

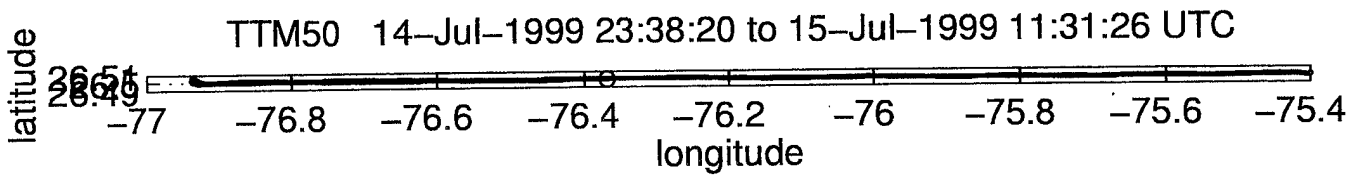

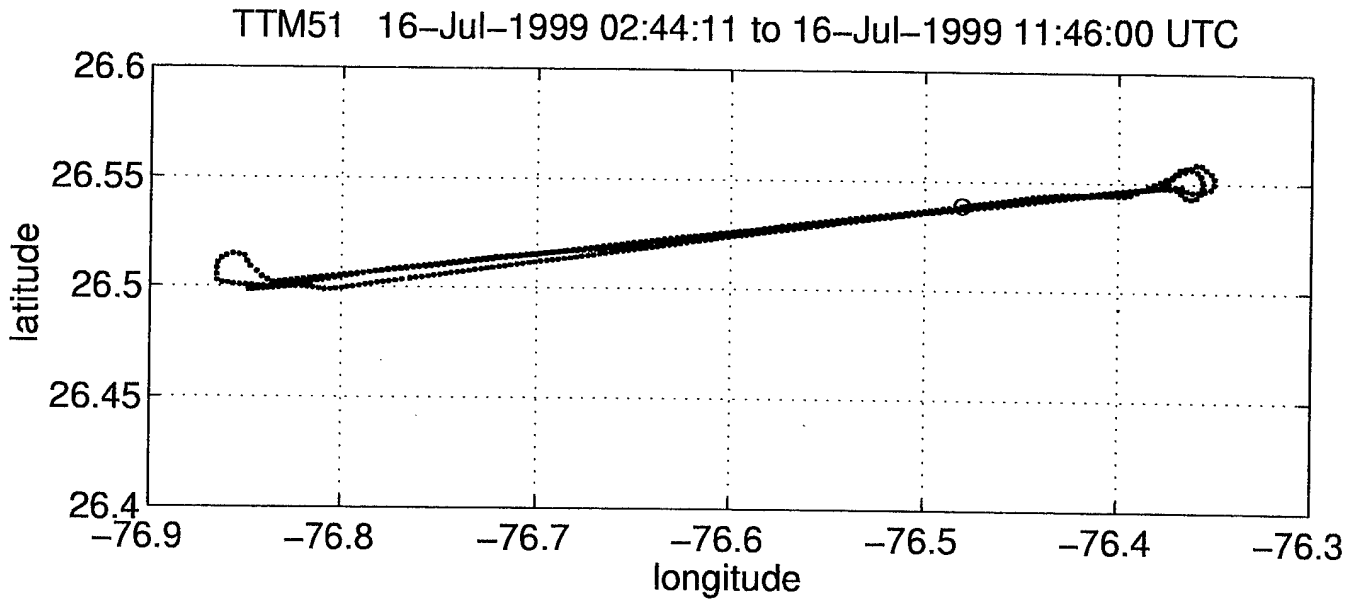

TTM52 17-Jul-1999 03:50:48 to 17-Jul-1999 13:01:46 UTC

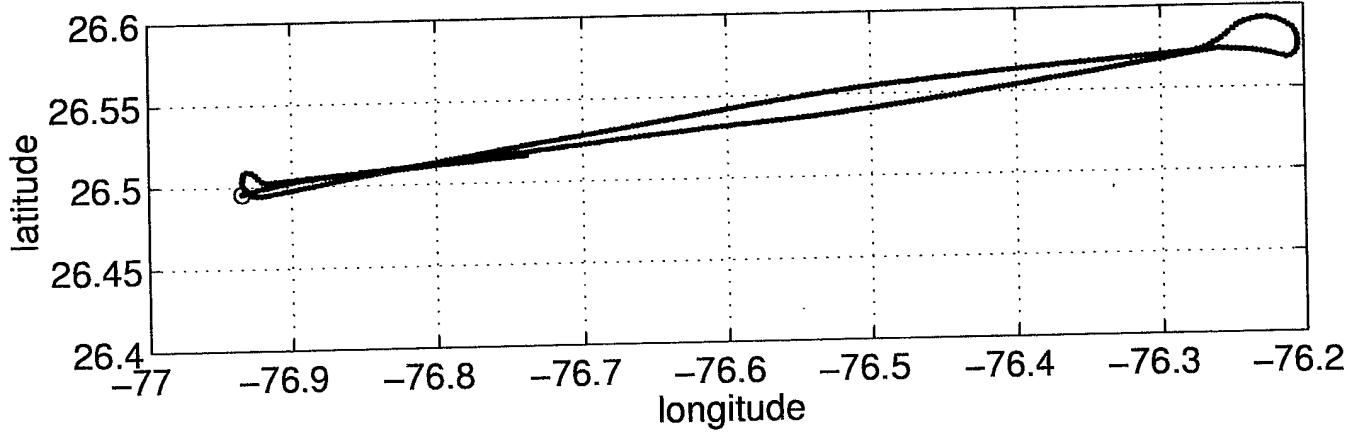

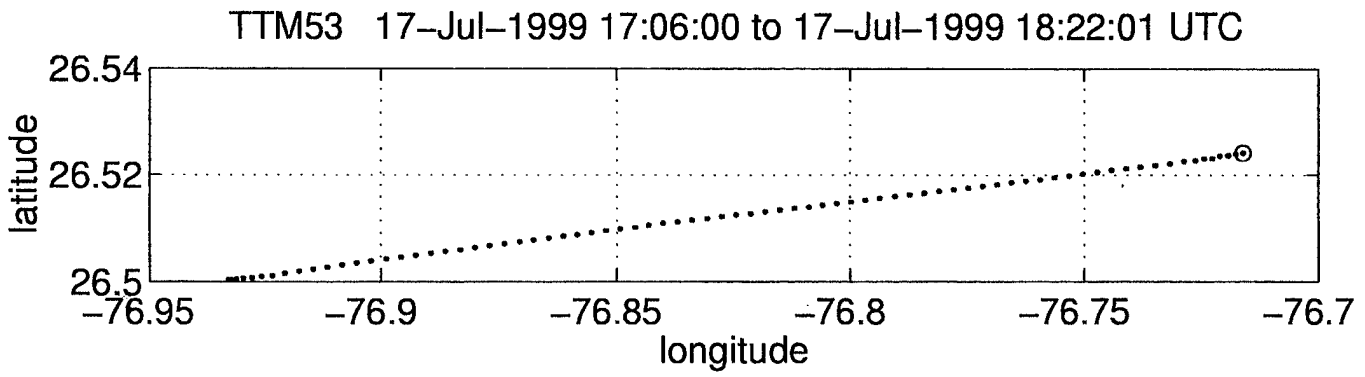

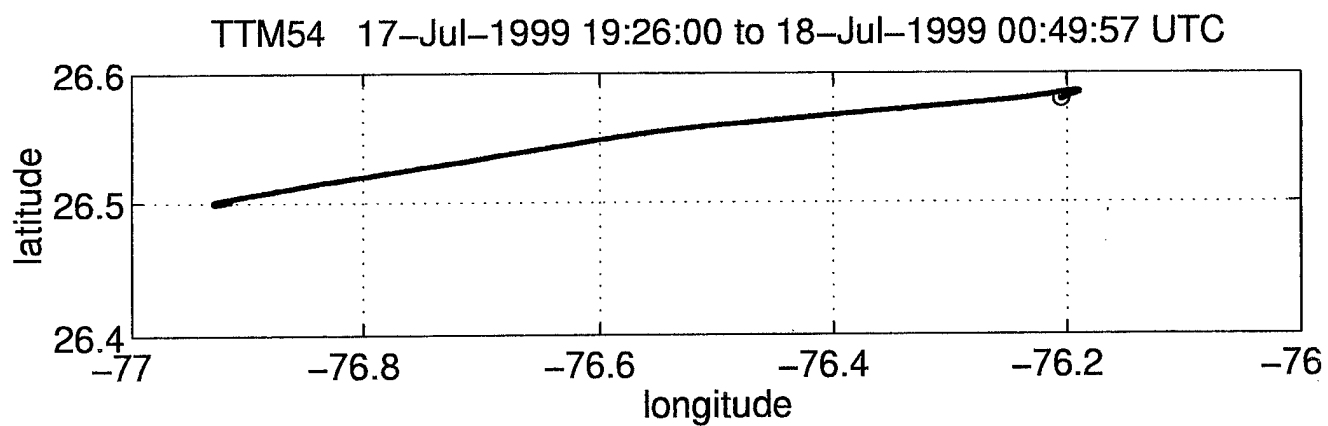

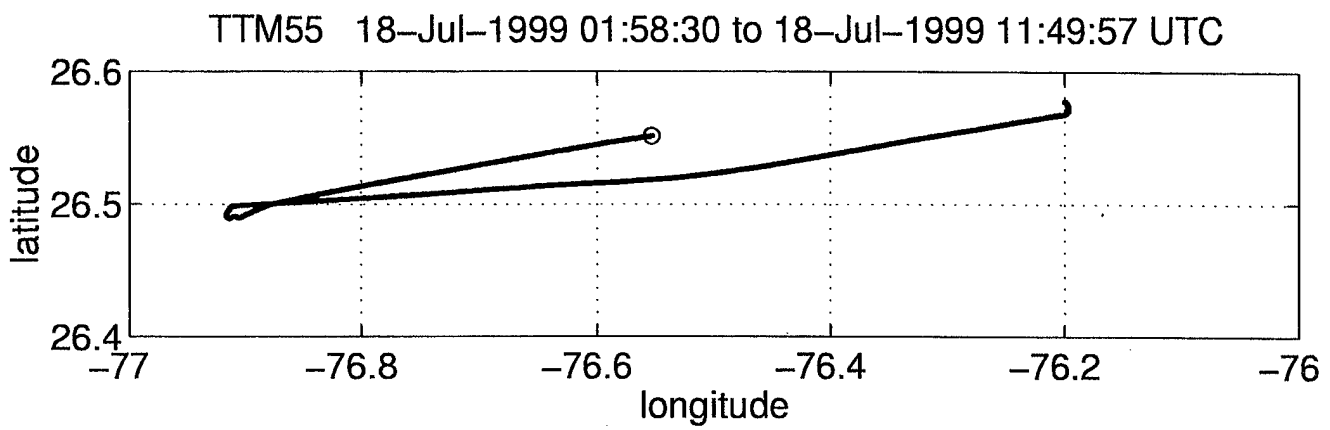

**APPENDIX B**

*R/V Seward Johnson* Cruise 9908

CTD Deployment Summary

and

Graphs

**CTD Casts - Bahamas, Including Abaco - July 1999**

<i>Cast No.</i>	<i>Date-Time(EST) yymmdd-hhmmss</i>	<i>Latitude North</i>	<i>Longitude West</i>	<i>Depth (m)</i>	<i>Comments</i>
1	990710-133000	26 29.9297	78 14.7491	1071	Good data, bottles + EM-POGO release test
2	990714-161500	26 30.0259	75 23.8040	4500	Good data, bottles
3	990715-075000	26 29.9527	76 23.0698	4744	Good data, bottles
4	990715-120100	26 30.0491	76 35.0605	4740	Good data, bottles
5	990715-155300	26 30.0078	76 42.0464	3828	Good data, bottles
6	990715-191900	26 29.9759	76 49.9792	1086	Good data, bottles
7	990715-205500	26 30.0353	76 55.6989	498	Rocky start, then good data and bottles

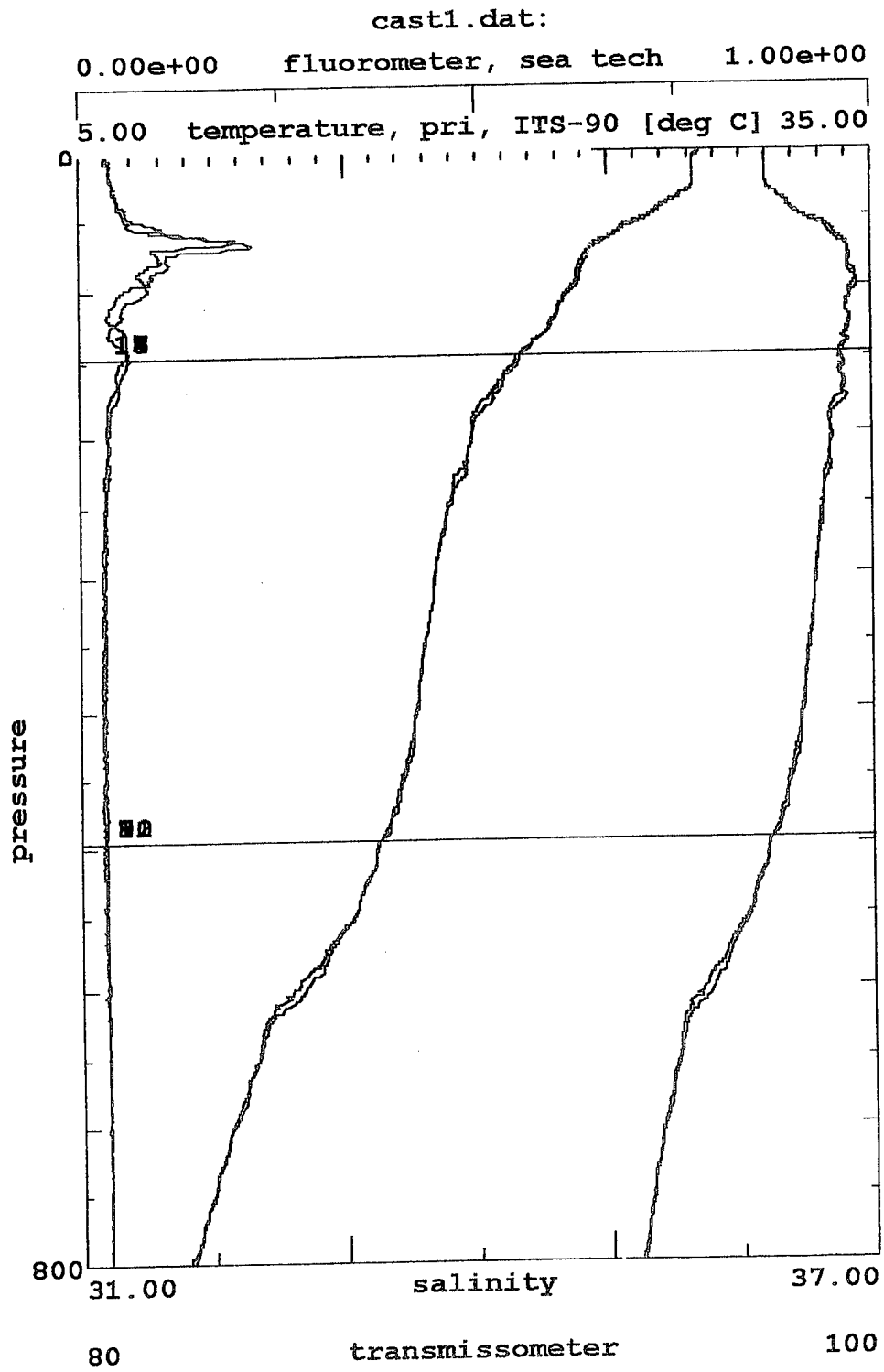

cast2.dat:

0.00e+00 fluorometer, sea tech 1.00e+00

2.90 temperature, pri, ITS-90 [deg C] 37.00

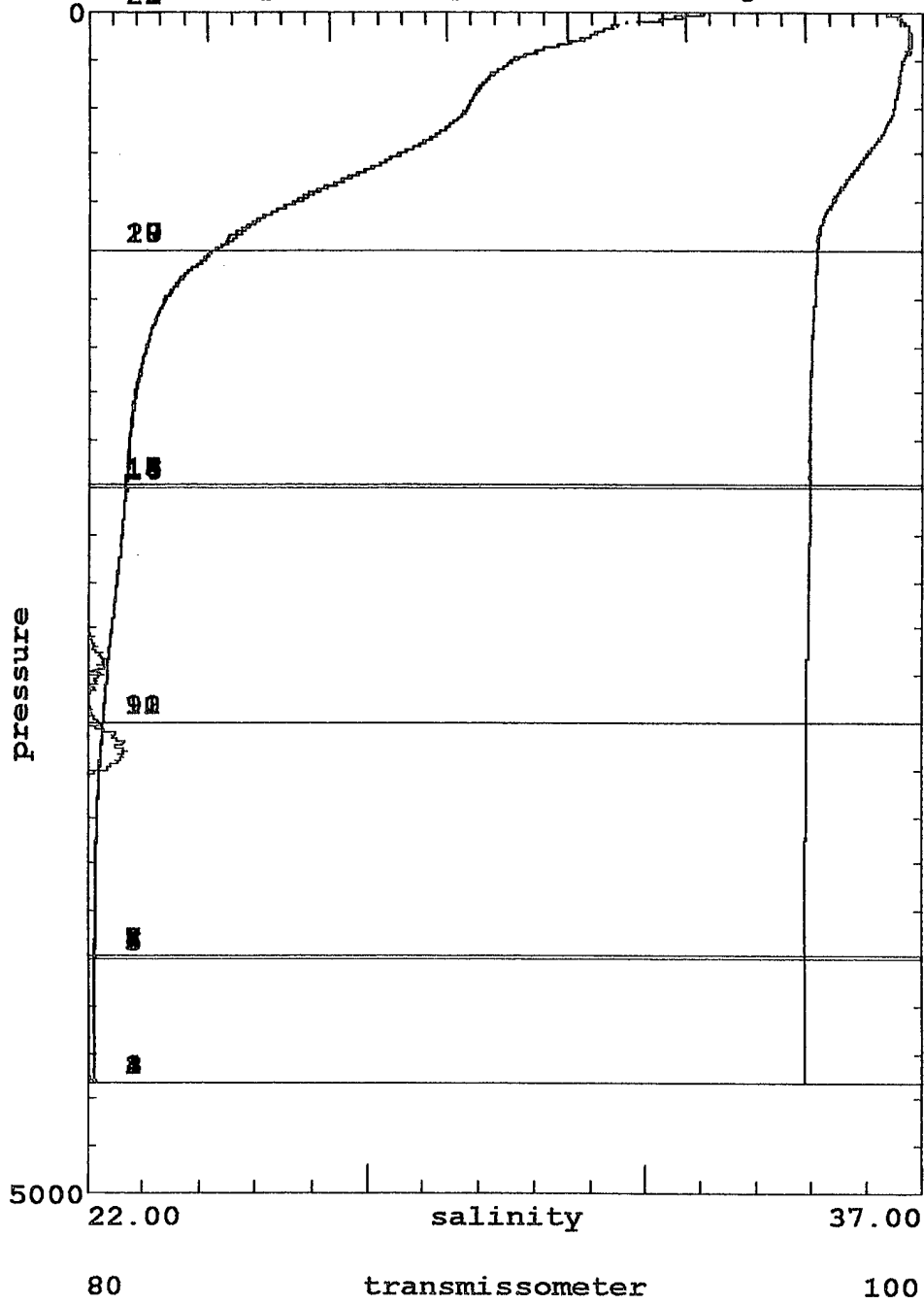

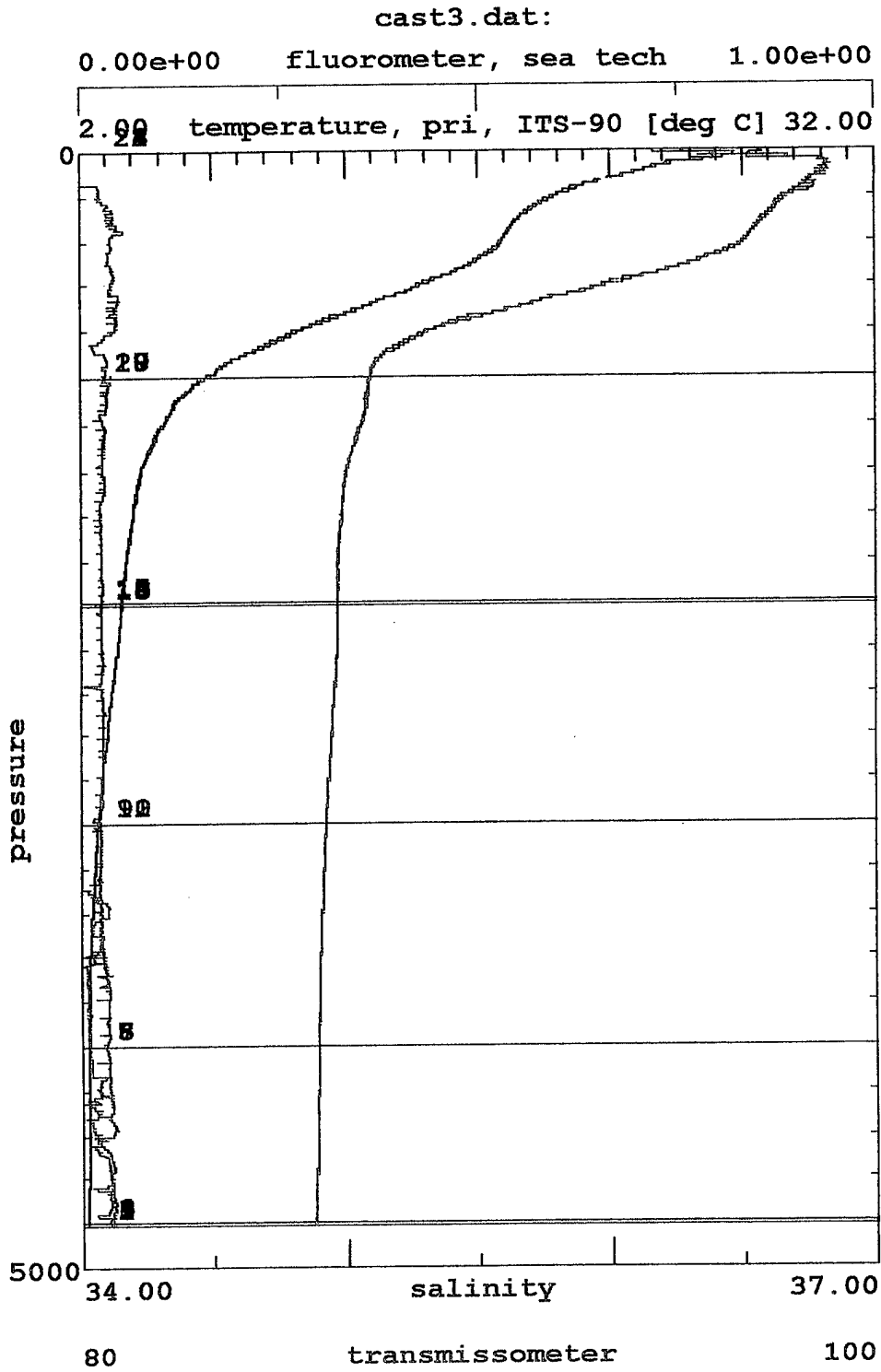

cast4a.dat:

0.00e+00 fluorometer, sea tech 1.00e+00

2.90 temperature, pri, ITS-90 [deg C] 32.00

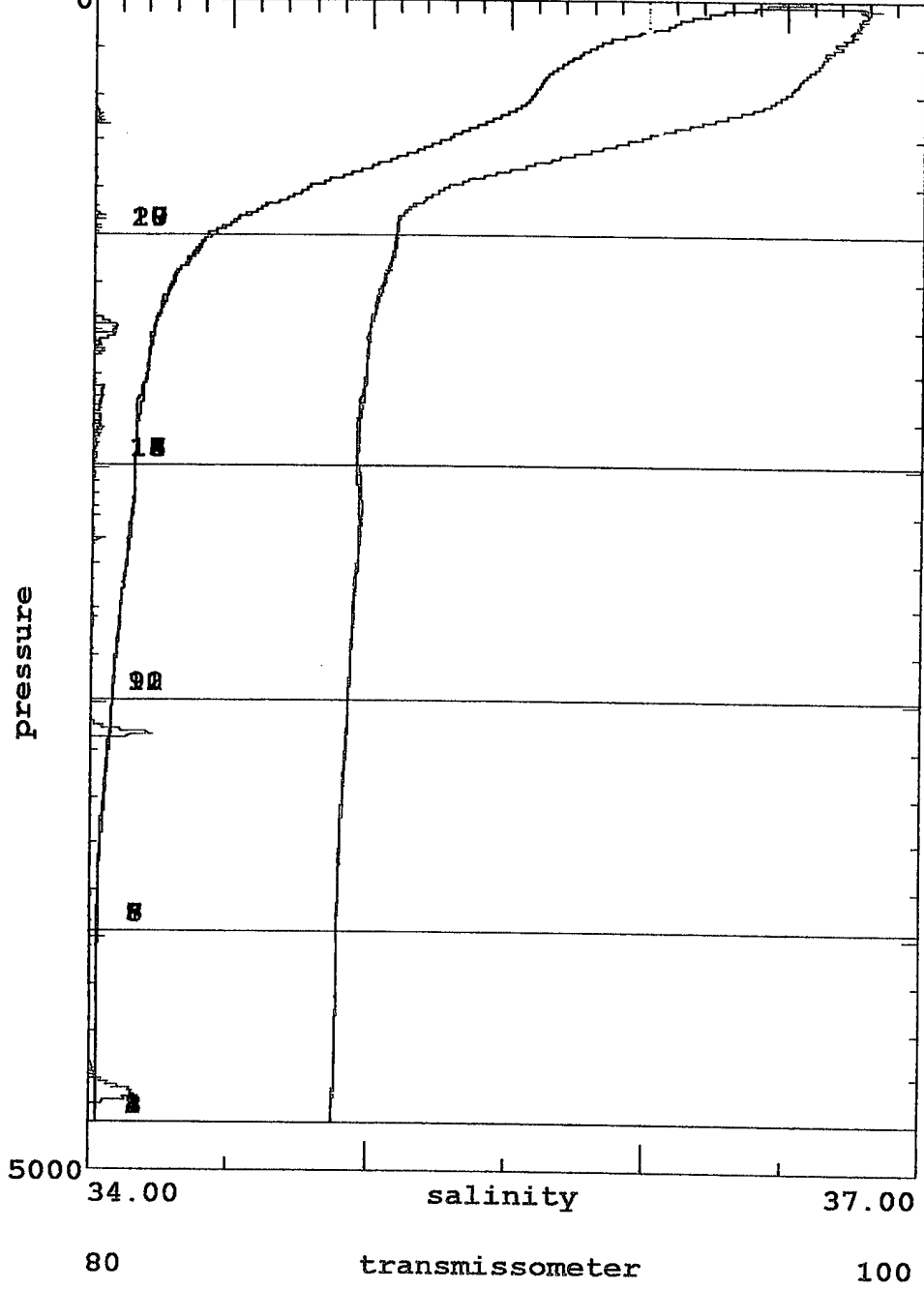

cast5.dat:

0.00e+00 fluorometer, sea tech 1.00e+00

2.20 temperature, pri, ITS-90 [deg C] 32.00

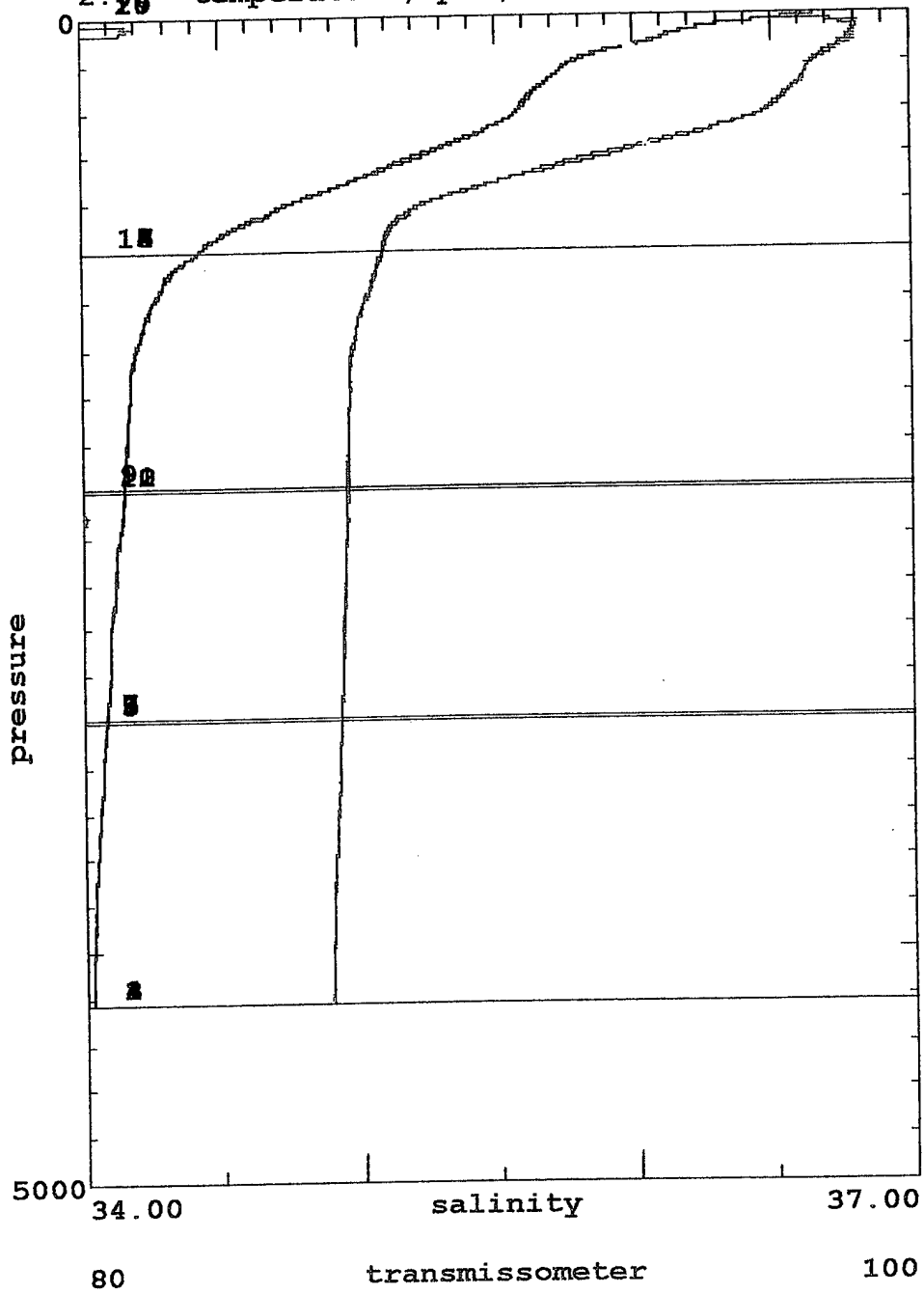

cast6.dat:

0.00e+00 fluorometer, sea tech 1.00e+00

2.92 temperature, pri, ITS-90 [deg C] 32.00

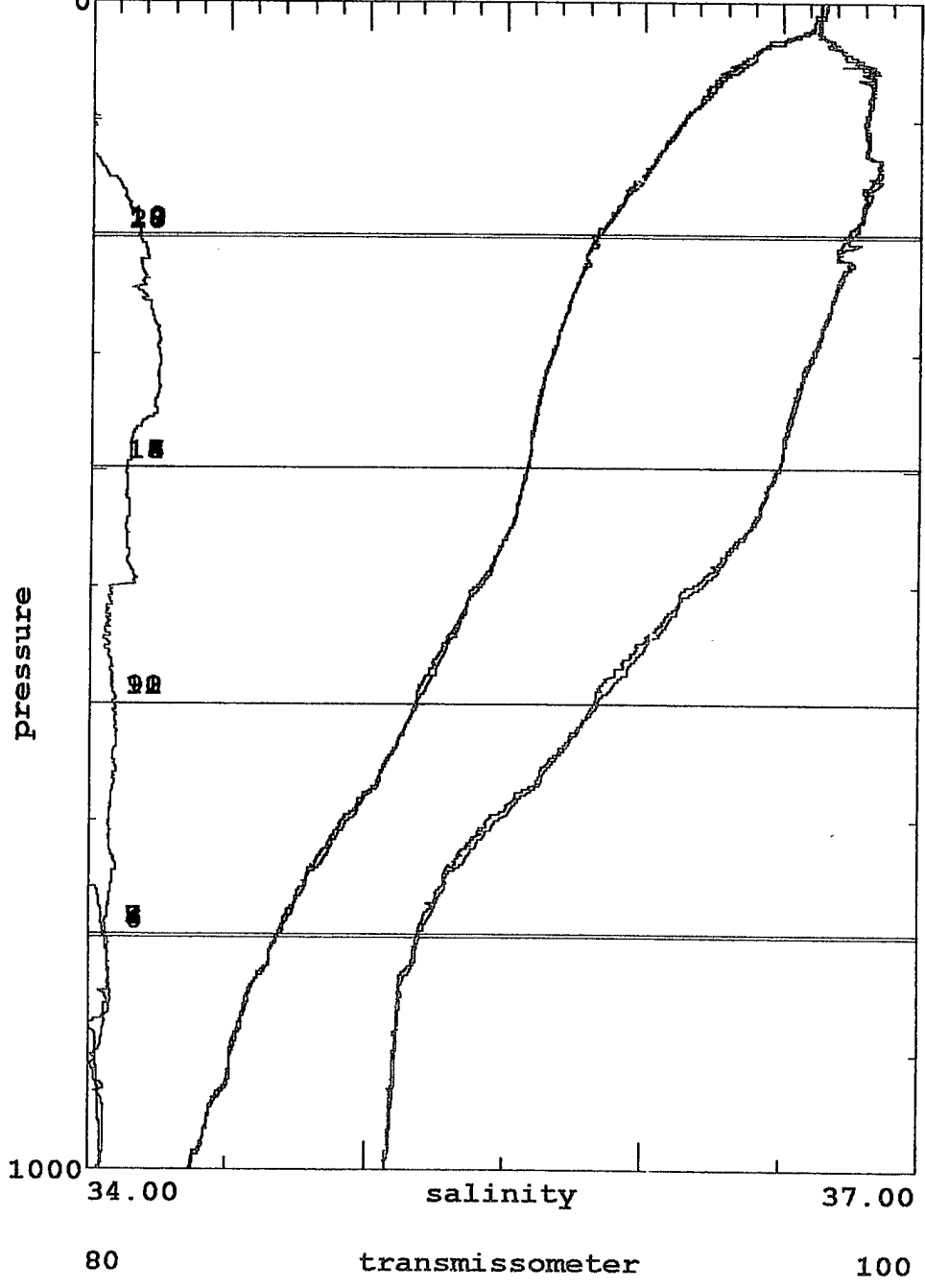

cast7a.dat:

0.00e+00 fluorometer, sea tech 1.00e+00

2.00 temperature, pri, ITS-90 [deg C] 32.00

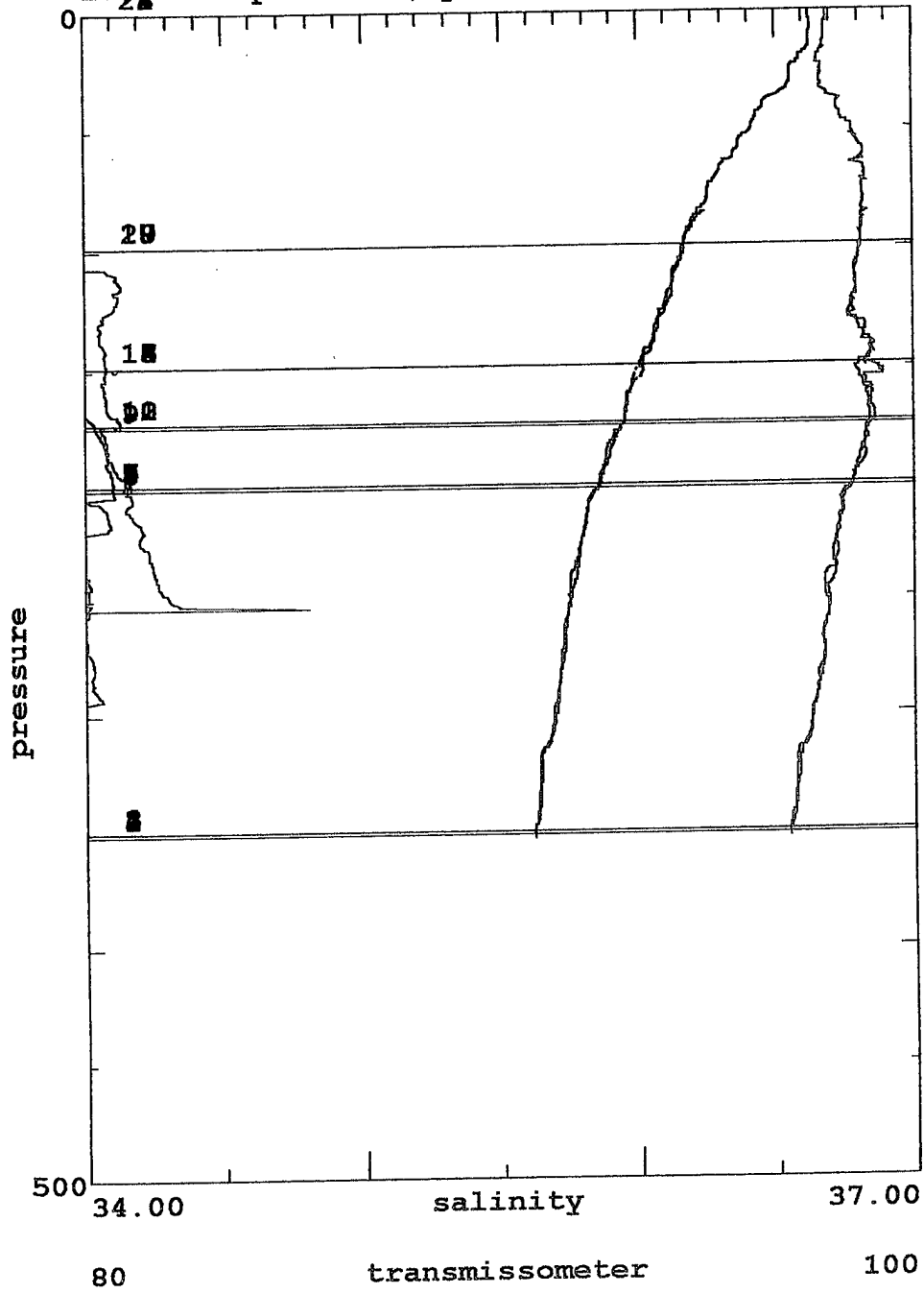

**APPENDIX C**

R/V *Seward Johnson* Cruise 9908

Guildline Autosol Data

## Guildline Autosol Data

Cruise	Station No.	Bottle No.	Salinity, ppt (24° Celsius)	Conductivity, S/m	Pressure, dbar
SJ9908	1	1	35.177377	2.009009	856
SJ9908	1	3	35.177942	2.009038	856
SJ9908	1	5	35.177075	2.008994	856
SJ9908	1	7	36.22414	2.062029	495
SJ9908	1	9	36.232782	2.062465	495
SJ9908	1	11	36.237136	2.062685	495
SJ9908	1	13	36.763053	2.089227	148
SJ9908	1	15	36.763966	2.089273	148
SJ9908	1	17	36.765632	2.089357	148
SJ9908	1	19	36.218111	2.061724	surface
SJ9908	1	21	36.218124	2.061725	surface
SJ9908	1	23	36.218414	2.061739	surface

## Guildline Autosol (#1)

Cruise	Station No.	Bottle No.	Salinity, ppt (24° Celsius)	Conductivity, S/m	Pressure, dbar
SJ9908	2	1	34.885177	1.994164	4533
SJ9908	2	5	34.896362	1.994733	4000
SJ9908	2	9	34.925346	1.996206	3000
SJ9908	2	13	34.971282	1.998541	2000
SJ9908	2	17	35.11579	2.005882	1001
SJ9908	2	21	36.421349	2.071989	3

## Guildline Autosol (#2)

Cruise	Station No.	Bottle No.	Salinity, ppt (24° Celsius)	Conductivity, S/m	Pressure, dbar
SJ9908	2	3	34.885321	1.994171	4533
SJ9908	2	7	34.895235	1.994675	3999
SJ9908	2	11	34.922815	1.996077	3001
SJ9908	2	15	34.971295	1.998541	2000
SJ9908	2	19	35.116328	2.005909	1001
SJ9908	2	23	36.423409	2.072093	3

## Guildline Autosol Data

Cruise	Station No.	Bottle No.	Salinity, ppt (24° Celsius)	Conductivity, S/m	Pressure, dbar
SJ9908	3	1	34.880587	1.993931	4811
SJ9908	3	3	34.880692	1.993936	4810
SJ9908	3	5	34.895733	1.994701	4001
SJ9908	3	7	34.895536	1.994691	4001
SJ9908	3	9	34.925464	1.996212	3000
SJ9908	3	11	34.925254	1.996201	3000
SJ9908	3	13	34.967556	1.998351	2000
SJ9908	3	15	34.968645	1.998407	2000
SJ9908	3	17	35.099946	2.005077	1001
SJ9908	3	19	35.099145	2.005037	1000
SJ9908	3	21	36.158091	2.058691	1
SJ9908	3	23	36.15821	2.058697	1

## Guildline Autosol Data

Cruise	Station No.	Bottle No.	Salinity, ppt (24° Celsius)	Conductivity, S/m	Pressure, dbar
SJ9908	4	1	34.884665	1.994138	4800
SJ9908	4	3	34.881675	1.993986	4799
SJ9908	4	5	34.89749	1.99479	3981
SJ9908	4	7	34.898159	1.994824	3980
SJ9908	4	9	34.933242	1.996607	2999
SJ9908	4	11	34.933517	1.996621	3000
SJ9908	4	13	34.96	1.997967	2000
SJ9908	4	15	34.959817	1.997958	1997
SJ9908	4	17	35.092989	2.004724	1003
SJ9908	4	19	35.093343	2.004742	1004
SJ9908	4	21	36.515071	2.07672	0
SJ9908	4	23	36.521663	2.077053	0

## Guildline Autosol Data

Cruise	Station No.	Bottle No.	Salinity, ppt (24° Celsius)	Conductivity, S/m	Pressure, dbar
SJ9908	5	1	34.892953	1.994559	4235
SJ9908	5	3	34.893372	1.994581	4235
SJ9908	5	5	34.935865	1.996741	3000
SJ9908	5	7	34.935026	1.996698	3000
SJ9908	5	9	36.661625	2.084113	2000
SJ9908	5	11	34.960814	1.998009	2000
SJ9908	5	13	35.092503	2.004699	1001
SJ9908	5	15	35.093396	2.004745	1001
SJ9908	5	17	36.663396	2.084203	0
SJ9908	5	19	36.663317	2.084199	0

## Guildline Autosol Data

Cruise	Station No.	Bottle No.	Salinity, ppt (24° Celsius)	Conductivity, S/m	Pressure, dbar
SJ9908	6	1	35.077199	2.003922	1001
SJ9908	6	3	35.078013	2.003963	1000
SJ9908	6	5	35.191441	2.009723	800
SJ9908	6	7	35.193949	2.009851	800
SJ9908	6	9	NA	NA	601
SJ9908	6	11	35.826364	2.041911	600
SJ9908	6	13	36.495005	2.075707	400
SJ9908	6	15	36.497026	2.075809	400
SJ9908	6	17	36.746879	2.088412	200
SJ9908	6	19	36.744063	2.08827	200
SJ9908	6	21	36.669491	2.08451	0
SJ9908	6	23	36.669636	2.084517	0

## Guildline Autosol Data

Cruise	Station No.	Bottle No.	Salinity, ppt (24° Celsius)	Conductivity S/m	Pressure, dbar
SJ9908	7	1	36.554535	2.078711	351
SJ9908	7	3	36.552381	2.078603	351
SJ9908	7	5	36.779863	2.090075	201
SJ9908	7	7	36.782046	2.090185	201
SJ9908	7	9	36.851112	2.093665	174
SJ9908	7	11	36.85262	2.093741	174
SJ9908	7	13	36.85258	2.093739	149
SJ9908	7	15	36.840541	2.093133	150
SJ9908	7	17	36.807045	2.091445	100
SJ9908	7	19	36.811556	2.091672	100
SJ9908	7	21	36.691675	2.085629	0
SJ9908	7	23	36.691304	2.08561	0

**APPENDIX D**

*R/V Seward Johnson* Cruise 9908  
EM-POGO Deployment Summary

**EM-POGO Deployments - Bahamas, Including Abaco - July 1999**  
**R/V Seward Johnson**

<i>Depl. No.</i>	<i>Date-Time (EST,) yyymmdd-hhmmss</i>	<i>Latitude North</i>	<i>Longitude West</i>	<i>Depth, meters</i>	<i>Comments</i>
1	990710-143500	26 30.0630	78 14.8962	1065	Instrument in water.
1	990710-144000	26 30.0891	78 14.8096	1073	EM-POGO at depth.
1	990710-144800	26 30.0768	78 14.6821	n/a	EM-POGO on board.
2	990710-171200	26 30.1676	78 14.5193	1200	EM-POGO deployed on tether but allowed to freefall with 10# of weight.
2	990710-173500	26 29.8955	78 13.9586	n/a	EM-POGO on deck.
3	990711-095900	26 29.9956	78 12.5493	1125	EM-POGO deployed and recovered on tether for radio check.
4	990711-104000	26 29.9050	78 12.2590	1220	Instrument in the water on tether.
4	990711-104800	26 29.9142	78 12.3001	1214	Instrument recovered.
5	990711-120000	26 30.0245	78 14.9978	1064	Instrument #2 deployed on tether.
6	990711-160200	26 29.9210	78 14.8630	n/a	EM-POGO deployed from fantail.
6	990711-162100	26 29.5090	78 14.6400	n/a	EM-POGO surfaced by hitting the bottom of the whaler.
6	990711-163000	26 29.6590	78 14.6500	n/a	EM-POGO towed back to ship from bow of whaler.
7	990713-130000	26 30.0496	78 14.9008	1066	EM-POGO deployed tethered.
7	990713-131000	26 30.0495	78 14.7690	1075	EM-POGO recovered from tether.
8	990713-141310	26 30.3093	78 14.7634	n/a	EM-POGO in water.
8	990713-142815	26 30.3431	78 14.9135	n/a	EM-POGO turned around.
8	990713-143300	26 30.3843	78 14.8869	0	EM-POGO hit surface.
8	990713-145600	26 30.0485	78 14.5049	1103	EM-POGO on board.

**Towed Transport Meter (TTM3)**  
**Normal<sup>1</sup> Launch & Recovery Procedure**  
**R/V *Seward Johnson* Cruise 9908**

TTM3 has two long tubes that are part of the tail assembly and which constitute the saltwater bridges to the electrodes in the instrument (see Figure 2 in main text). These tubes were shipped in a roll, so they had to be straightened before use by placing them in small-diameter pipes full of hot water for about 24 hours followed by ice water. After the instrument was fully assembled and before each deployment, it was necessary to fill the tubes completely with seawater and remove any air bubbles. This is because bubbles may lodge next to an electrode chamber or remain within a tube and change the impedance unpredictably. This filling and debubbling was accomplished by first opening the water-switch valves in the TTM3 (a magnetically activated reed switch and red LED provided operator interaction with the internal microcomputer), and then hoisting a bucket full of seawater high above the deck and draining it through the tubes and the instrument. The walls of each tube and the instrument were tapped continuously by team members to dislodge bubbles and allow them to move out of the tubes. When all the tubes were free of bubbles and full of seawater, a rope drogue was attached to the end of the longest tube, and the instrument was deployed off the fantail. During deployment, the ship was moving at 2–3 knots. The TTM3's nose and 20 m of tow line went in first while the end of the tail was held aboard. When the instrument and a sufficient loop of cable were in the water, the tail was released such that it would quickly enter the water and be dragged aft without gathering any bubbles. Recovery was effected simply by bringing the TTM3 on board, placing it in its storage box, and raising the end of the tubes so the electrodes stayed wet and the tubes mostly free of bubbles.

---

<sup>1</sup> The word "Normal" is used because different methods of filling were tried during this cruise in an attempt to remove air from the tubes.

## **APPENDIX E**

*R/V Seward Johnson* Cruise 9908  
Instrument Deployment and Recovery Procedures

TTM3 Checkout Sheet (Draft 2)

\_\_\_\_\_ tow number:

Date: July \_\_\_\_\_ 1999

Set Mission: using VersaTerm PRO

- \_\_\_\_\_ Download version(v) \_\_\_\_\_
- \_\_\_\_\_ Set save stream filename \_\_\_\_\_
- \_\_\_\_\_ Set TTM clock (R) \_\_\_\_\_
- \_\_\_\_\_ Start sampling time (s) = \_\_\_\_\_
- \_\_\_\_\_ Check Battery Voltage (a) = \_\_\_\_\_ Volts (beginning)
- \_\_\_\_\_ = \_\_\_\_\_ Volts (end)
- \_\_\_\_\_ Pressure counts = \_\_\_\_\_
- \_\_\_\_\_ Unset save stream
- \_\_\_\_\_ Plunger position = \_\_\_\_\_ inches (beginning)
- \_\_\_\_\_ = \_\_\_\_\_ inches (end)
- \_\_\_\_\_ Tail Reassembled
- \_\_\_\_\_ Tape tow line back to TTM pressure housing
- \_\_\_\_\_ Check Plug -- Add grease -- Insert Plug
- \_\_\_\_\_ Check Blinking light

Attach line and hardware:

- \_\_\_\_\_ Check line
- \_\_\_\_\_ Check swivels
- \_\_\_\_\_ Attach tow line and safety wire
- \_\_\_\_\_ Flush (one long red light pulse)
- \_\_\_\_\_ Unflush (three long red pulses) -- ready to deploy
- \_\_\_\_\_ Add rope tail
- \_\_\_\_\_ **Remove nose tape**
- \_\_\_\_\_ Slow ship to 2 knots
- \_\_\_\_\_ (increase to 6 during deployment)

Deploy:

- \_\_\_\_\_ Time Deployment begins: \_\_\_\_\_
- \_\_\_\_\_ Time Deployment ends: \_\_\_\_\_

Recover

- \_\_\_\_\_ Recovery time \_\_\_\_\_
- \_\_\_\_\_ Offload filename(x) \_\_\_\_\_
- \_\_\_\_\_ Put on nose tape & tape back tow line
- \_\_\_\_\_ Stopped acquisition time: \_\_\_\_\_

note (TTM command)

EM-POGO Checkout Sheet (Draft)

Date: \_\_\_\_\_

Position: \_\_\_\_\_

Water Depth: \_\_\_\_\_

EM-POGO drop no.: \_\_\_\_\_

EM file

name: \_\_\_\_\_

Instrument Serial No.: \_\_\_\_\_

GPS POGO file

name: \_\_\_\_\_

EM section setup:

EPROM \_\_\_\_\_ or Download Version \_\_\_\_\_

Set or check TT5 clock: \_\_\_\_\_

+ Bat 4 \_\_\_\_\_

- Reg 5 \_\_\_\_\_

- Reg 6 \_\_\_\_\_

Time EM Acquisition **starts**: \_\_\_\_\_

Time EM Acquisition **ended**: \_\_\_\_\_

GPS-POGO Section Setup:

**Time of POGO magnet removal to start acquisition:** \_\_\_\_\_

(nearest second)

Battery Voltage: \_\_\_\_\_

Bottom Release: \_\_\_\_\_

(or)

Pressure Release \_\_\_\_\_

Piston Size: \_\_\_\_\_

Screw neck diameter: \_\_\_\_\_

Expected Release Depth: \_\_\_\_\_

Drop Weight (g): \_\_\_\_\_

Attach Release and Weights: \_\_\_\_\_

Time Release slip line: \_\_\_\_\_

Time recovery line attached: \_\_\_\_\_

## **APPENDIX F**

*R/V Seward Johnson* Cruise 9908

### Schedule of Operations

The following schedule was created during the cruise from the original Plan of Operations. Most of the information was updated as the cruise progressed, but occasionally the times and positions are only approximations from the original plan. A more accurate handwritten log was kept and used for Appendices A, B, and D.

Plan of Operations  
Seward Johnson 9-20 July 1999

Tom Sanford, Chief Scientist

Time (local)	Position (lat, long)	Depth	Operation	Comments
<i>9 July 1999</i>				
0630	27°32N, 80°21W	Harbor	Dep. HBOI	Depart HBOI dock, head for Ft. Pierce Inlet
0800	27°29N, 80°16W	Harbor	Dep. Ft. Pierce In.	Offshore of Pt. Pierce Inlet; torque sensor tests
1346	27°13N, 79°57W	50 fm	Deploy TTM41	Head S. along 50 fm at spds up to 12 kn
1532	27°00N, 79°58W	50 fm	Recover TTM41	Examine data; prepare TTM;
1900	26°56N, 79°57W	50 fm	Deploy TTM42	Once TTM in and ship spd 8 kn, head to 20 fm, make wide turn and head to Settlement Pt. On constant hdg
<i>10 July 1999</i>				
0203	26°42N, 79°04W	Various	End transect	Off Settlement Pt.; head to Freeport, GBI
0438	26°29N, 78°49W	Harbor	Recover TTM42	End of TTM tow; examine data
0630	26°31N, 78°47W	Harbor	Clear customs	Enter Freeport; clear Bahama customs
			Ballast EM-POGO	Remain in harbor to ballast the EM-POGOs
1000	26°31N, 78°47W	Harbor	Dep. Freeport	Depart Freeport
1015	26°28N, 78°47W	1200 m	Deploy TTM43	Put in S. of Freeport, head E. to next site at 10 kn
1311	26°30N, 78°15W	1200 m	Recover TTM43	Examine data
1330	26°30N, 78°15W	1200 m	Test rel., CTD01	Put pressure release on CTD wire; test to 700 m
1400	26°30N, 78°15W	1200 m	Lower EMP001	First use of EM-POGO2, lowered on line to 50 m
1712	26°30N, 78°15W	1200 m	Lower EMP002	EM-POGO2, lowered on line to 100 m; radio chk
2021	26°30N, 78°15W	1200 m	Deploy TTM44	Begin boxes.
2028	26°29N, 78°15W	1177 m	TTM44 box#1	Tow CW box, 1/2 hr sides, legs on cardinal magnetic directions, 10 kn. Start S.
2236	26°30N, 78°15W	1071 m	TTM44 box#2	Tow CCW box, legs on cardinal magnetic directions, 1/2 hr sides, 10 kn. Start S.
<i>11 July 1999</i>				
0114	26°30N, 78°15W	1170 m	TTM44 box#3	Tow CW box, 1/2 hour sides, legs on cardinal magnetic directions; 8 kn. Start S.
0350	26°30N, 78°16W	1100 m	TTM44 box#4	Close box#3, begin box #4 CCW. 1/2 hr sides 8 kn. Start S.
0628	26°30N, 78°14W	1141 m	TTM44 box#5	Close box#4, begin box#5 CW. 1/2 hr sides. 6 kn. Start S.
0900	26°30N, 78°15W	1200 m	Recover TTM44	Download and examine data
0930	26°30N, 78°15W	1200 m	Deploy EMP003	Tether #2 w/ Bathysystems' subsystem off
1000	26°30N, 78°15W	1200 m	Recover EMP003	Examine data; coil and EF NG
1040	26°30N, 78°12W	1200 m	Deploy EMP004	Tether #1 w/ Bathysystems' subsystem off
1048	26°30N, 78°12W	1200 m	Recover EMP004	Examine data
1340	26°30N, 78°15W	1200 m	Deploy EMP005	Tether #2 w/ and w/o Bathysystems' off
1410	26°30N, 78°15W	1200 m	Recover EMP005	Examine data
1602	26°30N, 78°15W	1200 m	Deploy EMP006	Use 540 dbar release, use surface marker, ribbie
1621	26°30N, 78°15W	1200 m	Recover EMP006	Tow to Johnson, recover, examine data
1928	26°30N, 78°14W	1200 m	Deploy TTM45	Begin another night of boxes.
1935	26°30N, 78°13W	1200 m	TTM45 box#1	Begin box#1 CW, 1/2 hr sides, cardinal magnetic directions. 6 kn, starting E.
2210	26°30N, 78°13W	1213 m	TTM45 box#2	Close box#1, begin box#2 CCW. 1/2 hr sides 6 kn. Start W.

## Plan of Operations

Page 2

Time (local)	Position (lat, long)	Depth	Operation	Comments
12 July 1999				
0041	26°30N, 78°12W 8 kn. Start E	1229 m	TTM45 box#3	Close box#2, begin box#3. CW, 1/2 hr sides,
0309	26°29N, 78°13W	1238 m	TTM45 box#4	Close box#3, begin box#4. CCW, 1/2 hr sides, 8 kn. Start W.
0535	26°30N, 78°13W	1231 m	TTM45	Box#4 complete. Put out 100 m more of wire, head for Lucaya towing TTM3 at 12 kn.
0400	26°20N, 78°15W	200 m	Head for Freeport, GBI	
0700	26°29N, 78°36W	>500 m	Recover TTM45	Off Lucaya, Bell Channel, ready to enter port
0800	26°29N, 78°36W	Harbor	Enter Harbor	Disembark Tom Rossby and Mark Prater w/ boat
0845	26°28N, 78°45W	>500 m	Deploy TTM46	Head to site of earlier ops. at 10 kn
1030	26°30N, 78°15W	1200 m	TTM46 box#1	Begin box#1 CW, 1/2 hr sides, cardinal magnetic directions. 10 kn, start S., then W.
1253	26°30N, 78°15W	1213 m	TTM46 box#2	Close box#1, begin box#2 CCW, 1/2 hr sides 10 kn. Start S, then E
1530	26°30N, 78°15W 8 kn. Start S, then W	1229 m	TTM46 box#3	Close box#2, begin box#3. CW, 1/2 hr sides,
1800	26°30N, 78°15W 8 kn. Start S, then E,... close box#4	1238 m	TTM46 box#4	Close box#3, begin box#4. CCW, 1/2 hr sides,
2100	26°30N, 78°15W	1231 m	Recover TTM46	Recover TTM3, retrieve data
2210	26°30N, 78°15W	1231 m	Deploy TTM47	Deploy TTM3, turn to mag S
2210	26°30N, 78°15W 1/2 hr sides, 12 kn, Start S, E,... close box#5	1231 m	TTM47 box#5	Begin box#5, CCW, put out 100 m more wire,
13 July 1999				
0043	26°30N, 78°15W	1095 m	TTM47 box#6	Begin box#6, CW, 1/2 hr sides, 12 kn, Start S, then W, close box#6 on E course
0306	26°30N, 78°15W	1231 m	TTM47	Continue E for 1/2 hr more
0335	26°31N, 78°08W	1219 m	TTM47 reciprocal#1	Make wide U-turn, slow to 8 kn, retrace previous E leg, 1 hr
0514	26°30N, 78°16W	1081 m	TTM47 reciprocal#2	Head SE + make S to N leg, 8 kn, 1 hr, cross reciprocal#1 in middle, make wide U-turn at end, retrace previous leg
0842	26°30N, 78°15W	1231 m	TTM47 reciprocal#3	Head NW + make W to E leg, 10 kn, 1 hr, cross reciprocal#2 in middle, make wide U-turn at end, retrace previous E leg
1156	26°30N, 78°20W	930 m	Recover TTM47	End of reciprocal#3, prep EM-POGO unit 2
1300	26°30N, 78°15W	1200 m	Deploy EMP007	Tethered drop of EM-POGO#2
1310	26°30N, 78°15W	1200 m	Recover EMP007	Recover EM-POGO, retrieve and examine data
1413	26°30N, 78°15W	1200 m	Deploy EMP008	Use 540 dbar release, move off 100 m
1456	26°30N, 78°15W	1200 m	Recover EMP008	Approach EM-POGO, recover from CTD A-frame
1637	26°30N, 78°15W	1200 m	Deploy TTM48	Head S at 10 kn
1640	26°30N, 78°15W	1200 m	TTM48 cross#1	10 kn, half hr run S, run to NW, turn E, half hr E tow to cross middle of previous S tow
1808	26°30N, 78°15W	1200 m	TTM48 cross#2	8 kn, S tow, half hr, run to NE, turn W, half hr W tow to cross middle of previous S tow
1939	26°30N, 78°15W	1200 m	TTM48 cross#3	6 kn, S tow, half hr, run to NW, turn E, half hr E tow to cross middle of previous S tow
2110	26°22N, 78°11W	1271 m	Recover TTM48	Recover, head to 26°30N, 76°56W off Marsh Hbr

## Plan of Operations

Page 3

Time (local)	Position (lat, long)	Depth	Operation	Comments
14 July 1999				
0752	26°30N, 76°56W	>100 m	Deploy TTM49	Tow TTM3 10 kn, E on 26.5°N, 80 nm (150 km)
1600	26°30N, 75°25W	5000 m	Recover TTM49	Retrieve and examine the data
1615	26°30N, 75°25W	5000 m	CTD02	CTD station to the bottom w/10 bottles
1945	26°30N, 75°25W	5000 m	Deploy TTM50	Tow back to Abaco Island along 26.5°N, 10 kn
15 July 1999				
0408	26°30N, 76°56W	>100 m	End of Abaco xsect	Make wide turn and go E on reciprocal course
0732	26°30N, 76°23W	5000 m	Recover TTM50	Retrieve and examine the data
0745	26°30N, 76°23W	5000 m	CTD03	Station in middle of DWBC
1201	26°30N, 76°35W	5000 m	CTD04	Station in transition between Antilles and DWBC
1553	26°30N, 76°42W	4000 m	CTD05	Station in middle of Antilles Current
1919	26°30N, 76°50W	1000 m	CTD06	Shallow cast in Antillies Current
2045	26°30N, 76°53W	500 m	CTD07	Inshore of the Antillies Current
2244	26°30N, 76°53W	100 m	Deploy TTM51	Tow 10 kn on course mag E starting at 26.5°N, and 76°56W back and forth between 76°50W and 76°23W
16 July 1999				
0747	26°32N, 76°30W	4760 m	Recover TTM51	Retrieve and examine data
0946	26°31N, 76°41W	5000 m	Start shaft HP tests	Balanced, ±5%,±10% stbd vs port on RPMs at 8, 10 and 12 kn, downwind
2345	26°31N, 76°45W	500 m	Deploy TTM52	Continue tows along mag E-W line
17 July 1999				
0104	26°30N, 76°55W	75 m	TTM52 underway	U-turn offshore Abaco, head mag E for 3.5 hr
0430	26°34N, 76°17W	4754 m	TTM52 underway	Reciprocal course on mag W to Abaco
0900	26°30N, 76°55W	>100 m	Recover TTM52	Retrieve and examine the data
1300	26°30N, 76°56W	>100 m	Deploy TTM53	Continue tows along mag E-W line
1430	26°30N, 76°56W	>100 m	Recover TTM53	Turn E, retrieve and examine the data
1535	26°30N, 76°56W	>100 m	Deploy TTM54	Continue tows along mag E-W line
1913	26°30N, 76°17W	5000 m	Recover TTM54	Retrieve and examine the data
2200	26°34N, 76°12W	5000 m	Deploy TTM55	6 kn on course mag W to Abaco
18 July 1999				
0448	26°30N, 76°52W	1200 m	Underway TTM55	Turn E, go on mag E for 3.5 hours
0750	26°32N, 76°33W	5000 m	Recover TTM55	Retrieve and examine the data
0815	26°32N, 76°32W	5000 m	Underway	Steam at 12 kn to op area 26°30N, 78°15W Rebuild water switches and tubing, test in lab
1930	26°30N, 78°15W	1200 m	Arr.ops site	Wait for TTM3 to be rebuilt
19 July 1999				
0700	26°30N, 78°26W	>500 m	Arr. new site	Move closer to Freeport
1730	26°31N, 78°47W	Harbor	Enter Freeport	Tie up, shore leave until 0100

## Plan of Operations

Page 4

Time (local)	Position (lat, long)	Depth	Operation	Comments
20 July 1999				
0000	26°31N, 78°47W	Harbor	Harbor	Liberty ends
0100	26°31N, 78°47W	Harbor	Underway	Dep. Freeport, clear Bahama authorities
0156	26°28N, 78°47W	>500 m	Deploy TTM56	Off Freeport, <b>give it one last chance!</b>
0400	26°42N, 79°01W	Various	Underway	Off Settlement Pt.; 10 kn mag W to 50 fm off FL
0830	26°47N, 79°58W	130 m	Recover TTM56	Arr. off E. Coast of Florida, near W. Palm Beach It worked for an hour before failing
1230	27°29N, 80°16W	10 m	Underway	Arr. sea buoy at Fort Pierce inlet
1315	27°29N, 80°17W	10 m	Underway	Arr. Reefer Dock; clear US authorities
21 July 1999				
0830	27°32N, 80°21W	Harbor	Arr. HBOI	End of cruise

**APPENDIX G**

*R/V Seward Johnson* Cruise 9908  
Cruise Personnel

## Cruise Personnel

### Ship:

Vince Seiler	Captain	HBOI <sup>1</sup>
Robert Shakespeare	Chief Mate	HBOI
Corbin Massey	Mate	HBOI
Stewart Moreaux	Ch. Engineer	HBOI
Jim Gallagher	Asst. Engineer	HBOI
Stuart Meacham	2nd Asst. Engineer	HBOI
Scott Hopkinson	Seaman	HBOI
Aric Anderson	Seaman	HBOI
Jeffrey Artingstall	Seaman	HBOI
John Bolog	Steward	HBOI
Bige Meece	Steward's Asst.	HBOI

### Science:

Tom Sanford	Chief Scientist	APL-UW <sup>2</sup>
Bob Drever	Sr. Engineer	APL-UW
John Dunlap	Sr. Engineer	APL-UW
Dicky Allison	Scientist	APL-UW
Tom Rossby	Visiting Scientist	University of Rhode Island
Mark Prater	Visiting Scientist	University of Rhode Island
Chip Maxwell	Marine Tech	University of Miami
Tim McGovern	Marine Tech	University of Miami
Glen Hendricsson	Observer	U.S. Coast Guard

<sup>1</sup> Harbor Branch Oceanographic Institution

<sup>2</sup> Applied Physics Laboratory, University of Washington

# REPORT DOCUMENTATION PAGE

*Form Approved*  
*OPM No. 0704-0188*

Public reporting burden for this collection of information is estimated to average 1 hour per response, including the time for reviewing instructions, searching existing data sources, gathering and maintaining the data needed, and reviewing the collection of information. Send comments regarding this burden estimate or any other aspect of this collection of information, including suggestions for reducing this burden, to Washington Headquarters Services, Directorate for Information Operations and Reports, 1215 Jefferson Davis Highway, Suite 1204, Arlington, VA 22202-4302, and to the Office of Information and Regulatory Affairs, Office of Management and Budget, Washington, DC 20503.

<b>1. AGENCY USE ONLY</b> ( <i>Leave blank</i> )		<b>2. REPORT DATE</b> August 2000	<b>3. REPORT TYPE AND DATES COVERED</b> Technical	
<b>4. TITLE AND SUBTITLE</b> R/V <i>Seward Johnson</i> Cruise 9908: Cruise Report and Preliminary Results			<b>5. FUNDING NUMBERS</b> Contract NSF OCE 9731543	
<b>6. AUTHOR(S)</b> T.B. Sanford, M.D. Allison, and J.H. Dunlap				
<b>7. PERFORMING ORGANIZATION NAME(S) AND ADDRESS(ES)</b> Applied Physics Laboratory University of Washington 1013 NE 40th Street Seattle, WA 98105-6698			<b>8. PERFORMING ORGANIZATION REPORT NUMBER</b> APL-UW TM 7-00	
<b>9. SPONSORING / MONITORING AGENCY NAME(S) AND ADDRESS(ES)</b> National Science Foundation 4201 Wilson Boulevard Arlington, VA 22230			<b>10. SPONSORING / MONITORING AGENCY REPORT NUMBER</b>	
<b>11. SUPPLEMENTARY NOTES</b>				
<b>12a. DISTRIBUTION / AVAILABILITY STATEMENT</b>  Approved for public release; distribution is unlimited.			<b>12b. DISTRIBUTION CODE</b>	
<b>13. ABSTRACT</b> ( <i>Maximum 200 words</i> )  Seawater moving through the Earth's magnetic field generates electric and magnetic fields. This phenomenon is often called motional induction. Previous studies have shown that these motionally induced electric fields can be measured and interpreted in terms of the ocean's velocity field. This report presents results from tests of two instruments that observe motionally induced electric fields in the sea. One, the towed transport meter (TTM), observes three orthogonal components of the ocean's electric field near the surface as a function of distance along track. These data and observations of the motion of the towing ship permit determination of the vertically averaged velocity of the whole water column. The TTM3 was towed in various patterns, such as reciprocal courses and boxes, to determine its performance. The second instrument, EM-POGO, combines electric field observations similar to those of the TTM3 with GPS navigation. This instrument profiles in the vertical and produces a profile of the absolute velocity of the ocean from the surface to the bottom or 2000 m, whichever comes first. The resulting profile was compared with the velocity profile obtained from the ship's acoustic Doppler current profiler (ADCP). The field tests were very useful. The TTM3 was found to be difficult to operate reliably, but the EM-POGO produced results in close agreement with those of the ship's ADCP.				
<b>14. SUBJECT TERMS</b> Motional induction, Towed Transport Meter, velocity profiles, ocean currents			<b>15. NUMBER OF PAGES</b> 65	
			<b>16. PRICE CODE</b>	
<b>17. SECURITY CLASSIFICATION OF REPORT</b> Unclassified	<b>18. SECURITY CLASSIFICATION OF THIS PAGE</b> Unclassified	<b>19. SECURITY CLASSIFICATION OF ABSTRACT</b> Unclassified	<b>20. LIMITATION OF ABSTRACT</b> SAR	