

ERDC/ITL TR-00-2

Information Technology Laboratory



**US Army Corps
of Engineers®**
Engineer Research and
Development Center

Computer-Aided Structural Engineering (CASE) Project

Reliability and Stability Assessment of Concrete Gravity Structures (RCSLIDE): User's Guide

Mary Ann Leggett, Michael E. Pace, Fredrick Lyles, and
Kevin Abraham

July 2000

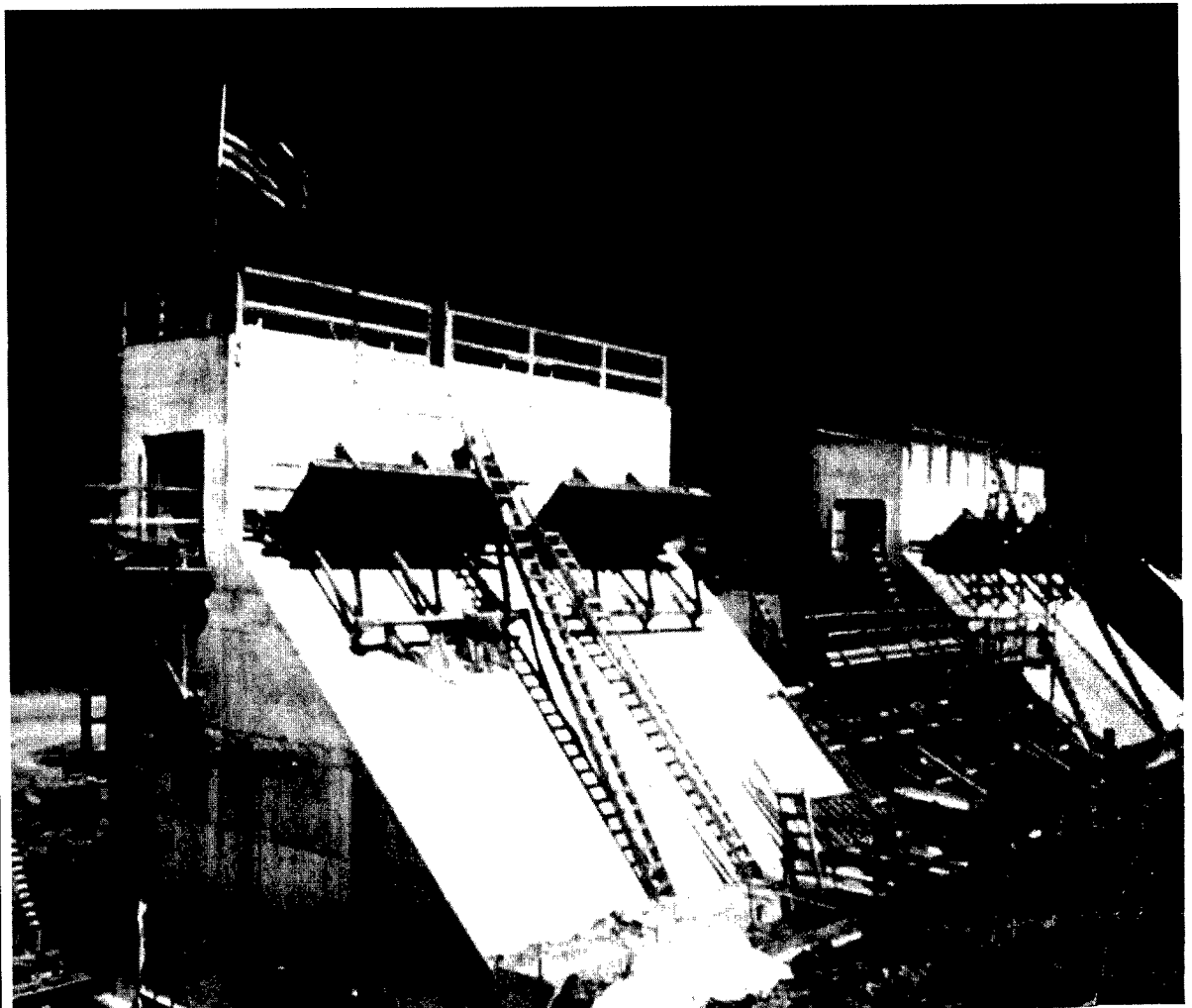

The contents of this report are not to be used for advertising, publication, or promotional purposes. Citation of trade names does not constitute an official endorsement or approval of the use of such commercial products.

The findings of this report are not to be construed as an official Department of the Army position, unless so designated by other authorized documents.



PRINTED ON RECYCLED PAPER

Reliability and Stability Assessment of Concrete Gravity Structures (RCSLIDE): User's Guide

By Mary Ann Leggett, Michael E. Pace, Fredrick Lyles, Kevin Abraham

Information Technology Laboratory
U.S. Army Engineer Research and Development Center
3909 Halls Ferry Road
Vicksburg, MS 39180-6199

Final report

Approved for public release; distribution is unlimited

20000831 058

Engineer Research and Development Center Cataloging-in-Publication Data

Reliability and Stability Assessment of Concrete Gravity Structures (RCSLIDE) : user's guide / by Mary Ann Leggett ... [et al.] ; prepared for U.S. Army Corps of Engineers.

348 p. : ill. ; 28 cm. -- (ERDC/ITL ; TR-00-2)

Includes bibliographic references.

1. RCSLIDE (Computer program) -- Handbooks, manuals, etc. 2. Retaining walls -- Stability -- Computer programs. 3. Retaining walls -- Reliability -- Computer programs. I. Leggett, Mary Ann. II. United States. Army. Corps of Engineers. III. Engineer Research and Development Center (U.S.) IV. Information Technology Laboratory (U.S.) V. Computer-aided Structural Engineering Project. VI. Series: ERDC/ITL TR ; 00-2.

TA7 E8 no.ERDC/ITL TR-00-2

Contents

Preface	viii
Conversion Factors	ix
1—Introduction	1
Purpose of Program CSLIDE	1
Organization of Report.....	1
Companion Manual.....	2
2—Overview of Sliding Stability Analysis	3
3—Development of the Governing Wedge Equation.....	7
Definition of Factor of Safety	7
Assumptions and Simplifications of Analysis	8
Sign Convention.....	8
Forces on Typical Wedge	10
Derivation of Governing Wedge Equation	12
4—Analysis Procedure	16
General Iteration Procedure	16
Procedure for a fixed failure surface	16
Procedure for a variable failure surface	17
CSLIDE Procedure.....	18
Factor of safety	18
Failure angles.....	19
Convergence criteria.....	19
Water Pressures.....	19
Input uplift pressures	20
Hydrostatic pressures.....	20
Input uplift force.....	20
Line of creep.....	20
Drainage efficiency	22
Limitations of Program	22
5—CSLIDE Input Terminology	24
Factor of Safety Ratio	24
Active Wedge-Structure Intersection Elevation	25
Input Wedge Angles.....	26
Factor of Safety Boundaries.....	26

Percent of Base in Compression	27
Seismic Loading.....	27
Single-Plane Failure Analysis.....	28
Multiple-Plane Failure Analysis	28
6—CSLIDE Output Terminology	30
Horizontal Loads.....	30
Vertical Loads.....	30
Water Pressures.....	31
Failure Angles.....	31
Length of Wedge.....	31
Weight of Wedge	31
Uplift Force.....	31
Net Force.....	31
Sum of Forces	32
Factor of Safety.....	32
Output Messages.....	32
Possible Solutions	33
7—Getting Started with RCSLIDE/CSLIDE	34
Installation.....	34
Minimum Program Requirements.....	34
RCSLIDE Overview	34
Title Screen	35
Menu bar.....	36
Title/Heading.....	38
Working with CSLIDE Files.....	38
New.....	39
Open.....	39
Save	39
Save As	40
Delete.....	40
Set Run options.....	40
Print	40
Exit	41
8—CSLIDE Input Guide	42
Minimum Required Data.....	43
Data Format and Sign Convention.....	44
Units and Sign Conventions.....	44
Title	45
Structural Information.....	45
Soil Description	48
Soil properties.....	48
Soil coordinates	50
Water Description	50
Seepage.....	53
Input uplift force.....	56
Drainage efficiency	56

Safety Factor	56
Loading Conditions.....	56
Anchors	62
Earthquake Conditions.....	62
Wedge-Angle Specifications.....	63
9—RCSLIDE Input Guide.....	65
Background	65
Working with RCSLIDE Files	66
Input Data.....	67
Mean	68
Standard deviation	68
Coefficient of variation	69
Code.....	69
Distribution.....	70
10—Program Output	73
Running CSLIDE	75
Running RCSLIDE	75
Output Files.....	80
CSLIDE analysis output	80
Advanced second moment output.....	80
Simulation output	81
Saving the Results.....	81
Run file menu	81
Run close selection	83
Performing multiple analysis.....	83
Main Menu file selection.....	83
Program termination	83
Viewing the Results.....	84
Graphical Output.....	87
References	94
Appendix A: Sliding Stability (CSLIDE) Data File.....	A1
Data Entry from a File	A1
Input Sections.....	A2
Input Syntax	A3
Required Data Description.....	A3
Title.....	A3
Structural information	A3
Left-side soil description	A4
Right-side soil description	A6
Soil below the structure.....	A10
Method of analysis	A12
Water description	A12
Termination of Data Input	A15
Optional Data Description	A17
Wedge-angle specification	A17
Earthquake conditions	A19

Factor of safety description	A19
Vertical surcharge loads	A19
Horizontal loads.....	A24
Appendix B: CSLIDE Example Problems.....	B1
Problem 1	B2
Problem 1A.....	B2
CSLIDE input sequence	B2
CSLIDE execution.....	B9
CSLIDE module output	B10
Hand Check of CSLIDE Results for Problem 1A, No Vertical Loads.....	B17
Summary of Problem 1A, No Vertical Loads	B23
Problem 1B.....	B23
Problem output	B27
Hand Check of CSLIDE Results for Problem 1B, Vertical Loads Applied	B35
Summary of Problem 1B, Retaining Wall with Vertical Surcharges	B38
Comments on Results, Problem 1, Parts A and B.....	B38
Problem 2	B39
Problem 2A.....	B39
Problem output	B41
Problem 2B.....	B47
Problem output	B50
Hand Check—Problem 2B, Earthquake Conditions Computations for External Loads Only.....	B59
Problem 3	B63
Problem 3A.....	B63
Problem output	B65
Problem 3B.....	B74
Problem output	B75
Hand Check—Problem 3, Seepage Calculations for “Reversed” Flow (Passive to Active Side).....	B83
Problem 4	B85
Problem 4A.....	B85
Problem output	B89
Problem 4B.....	B96
Problem output	B97
Problem 4C.....	B103
Problem output	B104
Problem 5	B112
Problem 5A.....	B113
Problem output	B113
Problem 5B.....	B117
Problem output	B118
Problem 6	B124
Problem 6A.....	B125
Problem output	B125

Problem 6B.....	B133
Problem output	B134
Problem 6C.....	B138
Problem output	B139
Problem 7.....	B146
Problem output	B148
Appendix C: RCSLIDE Example Problems.....	C1
Problem 1	C1
RCSLIDE input sequence.....	C3
RCSLIDE execution – CSLIDE analysis	C9
RCSLIDE execution – ASM method	C11
RCSLIDE module output	C14
Problem 2	C23
Problem 2A.....	C25
Problem 2A output.....	C27
Problem 2B.....	C36
Problem 2B output.....	C36
Problem 2C.....	C39
Problem 2C output.....	C40
Appendix D: CSLIDE/RCSLIDE Routines.....	D1
Main CSLIDE FORTRAN Program	D1
FORTRAN Subroutines	D1
FORTRAN Functions	D10
Visual Basic Subroutines	D11
Visual Basic Forms	D11
Flowchart	D12
Appendix E: Notation.....	E1

Preface

This report documents RCSLIDE, the reliability assessment version of CSLIDE, a computer program for assessing the sliding stability of concrete gravity structures. The windows-based reliability version of the program reported herein was funded under the Risk Analysis for Water Resources Investments Research and Development Program and the Reliability Models for Major Rehabilitation Reports Program at the U.S. Army Engineer Research and Development Center (ERDC). Funding for the development of the original CSLIDE program was provided by the Engineering and Construction Division, Directorate of Civil Works, Headquarters, U.S. Army Corps of Engineers (HQUSACE), under the Computer-Aided Structural Engineering (CASE) Project. Publication of this report was also provided by the CASE Project.

The main CSLIDE analysis algorithm was written by Mr. Michael E. Pace, Computer-Aided Engineering Division (CAED), Information Technology Laboratory (ITL), ERDC, Ms. Virginia N. Knowles and Mr. Dennis Williams, formerly of ITL, and Dr. Jay K. Jeyapalan, formerly of the University of Wisconsin, under the guidance of Dr. Reed L. Mosher, ERDC. Specifications for the program were prepared by the members of the CASE task group on G-CASE, currently the Soil-Structure Interaction task group. The reference for the original CSLIDE documentation is as "Sliding Stability of Concrete Structures (CSLIDE)" by Michael E. Pace and Virginia R. Noddin, Instruction Report ITL-87-5, U.S. Army Engineer Waterways Experiment Station, Vicksburg, MS. Creation of a windows interface and incorporation of reliability were performed by Drs. Bilal M. Ayyub and Ru-Jen Chao of BMA Engineering, Inc., and Messrs. Robert C. Patev, Amos Chase, Barry C. White, and Dr. Mary Ann Leggett, ITL. This report was prepared by Dr. Leggett and Mr. Fredrick Lyles, formerly of ITL. The example reliability problems were prepared by Mr. Kevin Abraham, ITL. The work was coordinated with HQUSACE, Directorate of Civil Works by Mr. Jerry Foster, Engineering and Construction Division, and Mr. Anil Chaudhry, Operations Division. The current work was performed under the general supervision of Mr. H. Wayne Jones, Acting Chief, CAED, and Dr. N. Radhakrishnan, former director of ITL.

At the time of publication of this report, Mr. Timothy Ables was Acting Director, ITL. Dr. Lewis E. Link was Acting Director of ERDC, and COL Robin R. Cababa, EN, was Commander.

Conversion Factors, Non-SI to SI Units of Measurement

Non-SI units of measurement use in this report can be converted to SI units as follows:

Multiply	By	To Obtain
degrees (angle)	0.01745329	radians
feet	0.3048	meters
kips (force)	4.44822	kilonewtons
kips (force) per square foot	47.880263	kilopascals
kips (mass) per cubic foot	16018.463	kilograms per cubic meter

1 Introduction

Purpose of Program CSLIDE

CSLIDE was developed to assess the sliding stability of concrete structures using the limit equilibrium method described in the Engineering Circular (EC) 1110-2-291, "Stability Analysis of Concrete Structures."

CSLIDE can compute the factor of safety against sliding by considering the effects of the following:

- a.* Multiple soil layers with irregular surfaces.
- b.* Water and seepage.
- c.* Applied vertical surcharge loads that include line, strip, triangular, uniform, and ramp loads.
- d.* Applied horizontal point loads.
- e.* Irregular-shaped structural geometry with a horizontal or sloped base.
- f.* A percentage of the base of the structure in compression because of overturning.
- g.* Single or multiple failure planes.
- h.* Horizontal and vertical induced loads because of earthquake accelerations.
- i.* Factors that require the user to predetermine the failure surface.

Organization of Report

The remainder of the report is organized as follows:

- a.* Chapter 2 gives an overview of the sliding stability analysis and defines pertinent terms used in the remainder of the report.

- b.* Chapter 3 discusses the theory involved in the limit equilibrium method presented in EC 1110-2-291. The assumptions used in this method are presented, and the general wedge equation is developed.
- c.* Chapter 4 discusses the analysis procedure and its program implementation.
- d.* Chapter 5 defines CSLIDE input terminology. The conditions that warrant the use of the options and their required data are presented.
- e.* Chapter 6 defines CSLIDE output terminology.
- f.* Chapter 7 describes program installation and the program's main menu bar.
- g.* Chapter 8 provides a guide to CSLIDE input by means of the program's windows.
- h.* Chapter 9 provides a guide to input of reliability information for RCSLIDE.
- i.* Chapter 10 provides a guide to program output.
- j.* Appendix A contains a user's guide for external creation of a CSLIDE data file.
- k.* Appendix B solves several example problems to demonstrate the CSLIDE analysis capabilities of the program.
- l.* Appendix C solves two example problems to demonstrate the reliability analysis capabilities of the program.
- m.* Appendix D contains a description of each routine in CSLIDE and a flowchart.
- n.* Appendix E is a notation listing symbols and abbreviations used in this report.

Companion Manual

The technical report "Reliability and Stability Assessment of Concrete Gravity Structures (RCSLIDE): Theoretical Manual" by Bilal M. Ayyub, Ru-Jen Chao, Robert C. Patev, and Mary Ann Leggett, Technical Report ITL-98-6, is a companion manual to this user's guide (Ayyub et al. 1998).

2 Overview of Sliding Stability Analysis

The purpose of a sliding stability analysis is to assess the safety of a structure against a potential failure because of the effects of excessive horizontal deformations. The potential for a sliding failure may be assessed by comparing the applied shearing forces with the resisting shearing forces. The resisting shearing forces are forces that are available because of the shear strength of the geologic material along an assumed failure surface. A sliding failure is imminent when the ratio of the applied shearing forces to the available resisting shearing forces is equal to one along an assumed failure surface.

The shape of the failure surface may be irregular depending on the homogeneity of the backfill and foundation material. The failure surface can be composed of any combination of plane and curved surfaces. For simplicity, all failure surfaces in CSLIDE are assumed to be planes that form the bases of wedges as shown in Figure 1.

Except for very simple cases, most sliding stability problems encountered in engineering practice are statically indeterminate. To reduce a problem to a statically determinate one, the problem must be simplified by dividing the system into a sufficient number of wedges and arbitrarily assuming the direction of the forces that act between the wedges.

Figure 2 illustrates how CSLIDE would divide the previously shown failure surface in Figure 1 into wedges. The base of a wedge is formed from either a section of the failure surface that lies in a single soil layer or along the base of the structure. The interface between any two adjacent wedges is assumed to be a vertical plane that extends from the intersection of the corners of the two adjacent wedges upward to the topsoil surface. The base of a wedge, the vertical interface on each side of the wedge, and the topsoil surface between the vertical interfaces define the boundaries of an individual wedge.

The failure mechanism, as shown in Figure 2, is composed of three types of wedges: a set of active wedges, a single structural wedge, and a set of passive wedges. Each active wedge has a net driving shearing force that exceeds the net available resisting shearing force. This force imbalance results in a net horizontal driving force applied by the active wedge. The base of each active wedge is

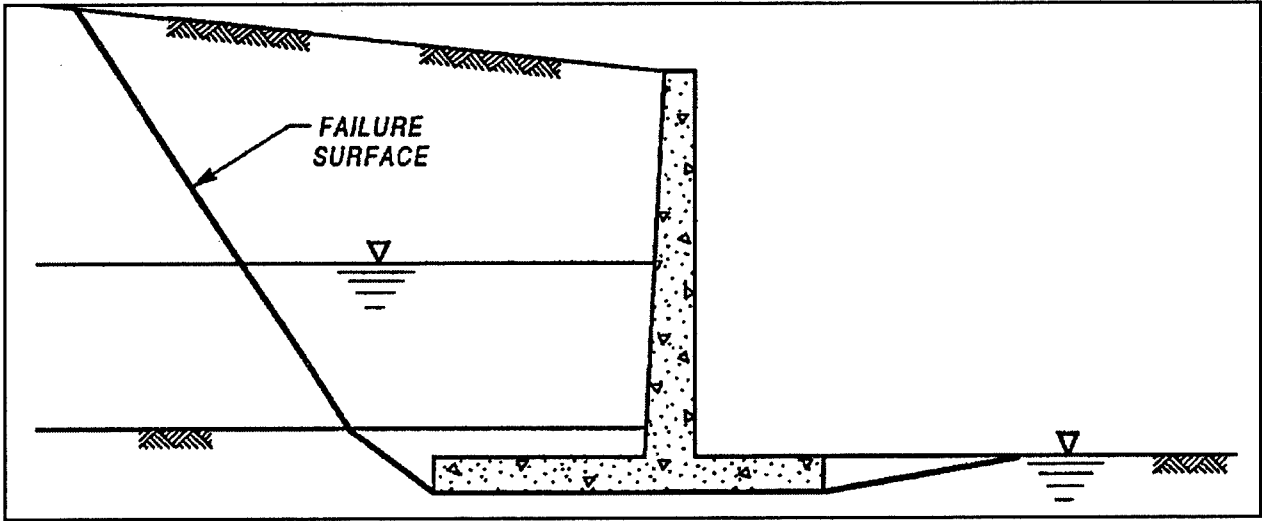

Figure 1. Typical soil/structure system with an assumed failure surface

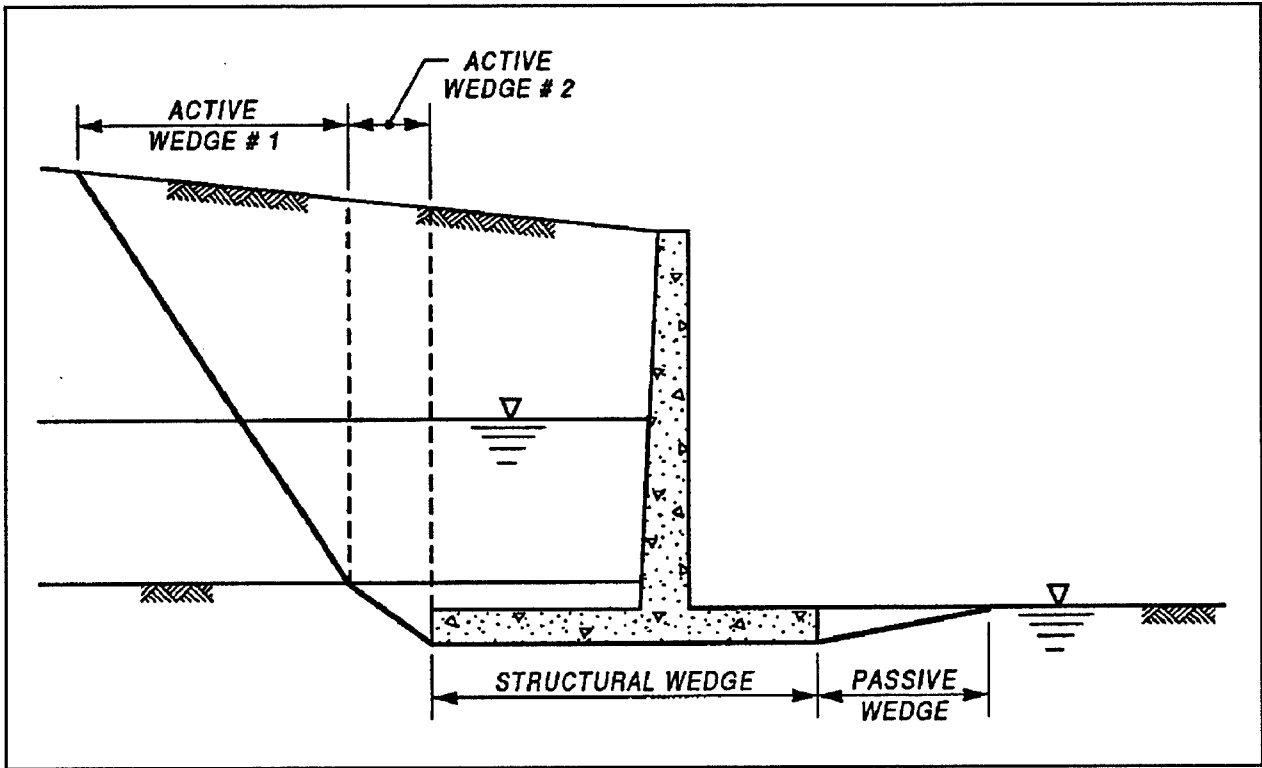

Figure 2. Typical stem of wedges

inclined at an angle that produces the maximum driving force for the wedge's geometry, loading conditions, and developed shear strength properties.

The next type of wedge is the structural wedge. If the failure plane for the structural wedge is assumed to coincide with the base of the structure, the structural wedge will be comprised of the structure and any soil above the base of the

structure. If the failure plane for the structural wedge is defined below the base of the structure, the additional soil below the base of the structure and above the failure plane will also be included in the structural wedge.

The structural wedge may add to the resisting or driving forces that act on the system of wedges. Whether the structural wedge exerts a driving or resisting force depends on the base slope of the structural wedge and on the loads applied to the structural wedge.

The last type is the passive wedge. Each passive wedge has a net available resisting shearing force that exceeds the net driving shearing force. This force imbalance results in a net horizontal resisting force applied by the passive wedge. The base of each passive wedge is inclined at an angle that produces the minimum resisting force for the geometry, loading conditions, and developed shear strength properties of the wedge.

Depending on the geologic conditions of the foundation material, the total failure surface or parts of the failure surface may be constrained. The inclination of some of the failure planes or the starting elevation of the failure planes adjacent to the structure may be known because of natural constraints at the site. Conditions that warrant the predetermination of parts of the failure surface include bedding planes or cracks in a rock foundation as shown in Figure 3.

Usually an iterative procedure is needed to find the critical failure surface. For an assumed factor of safety, the inclination of the base of each wedge is varied to produce a maximum driving force for an active wedge or a minimum resisting force for a passive wedge. The assumed factor of safety affects the critical inclination of the base of each wedge. The factor of safety is varied until a failure surface is produced with a set of driving forces equal to the resisting forces. The failure surface resulting from this procedure will be the most critical failure surface. A more detailed explanation of this iteration procedure and conditions that affect the inclination of the failure planes is provided further into this report.

The analytical procedures previously discussed are employed in the computer program CSLIDE and are set forth in EC 1110-2-291. This EC updated the design criteria for stability analysis of concrete structures based on a limit equilibrium approach. EC 1110-2-291 was released by the Headquarters, U.S. Army Corps of Engineers, to replace Engineer Technical Letter (ETL) 1110-2-256, which replaced the shear-friction concept in ETL 1110-2-184. The development of the governing wedge equation used in EC 1110-2-291 and its implementation in CSLIDE are presented in the next section.

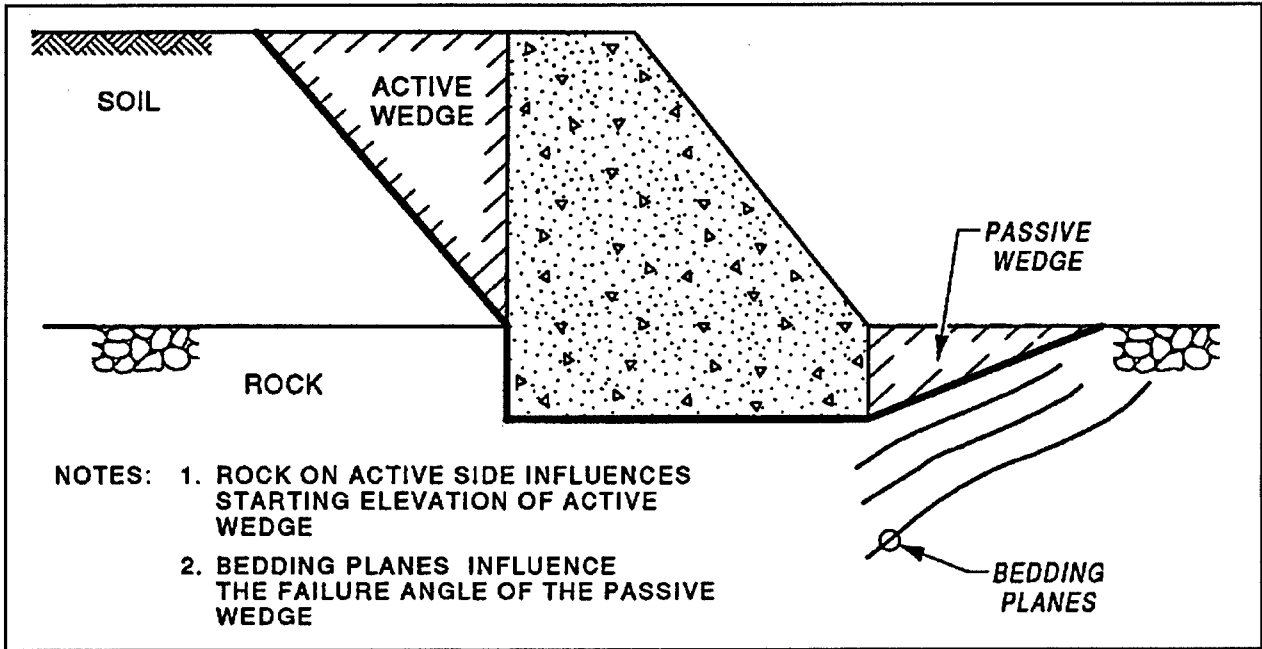

Figure 3. Predetermined failure surface

3 Development of the Governing Wedge Equation

Definition of Factor of Safety

The limit equilibrium analysis procedures that are described in EC 1110-2-291 are based on presently accepted geotechnical principles that consider the shear strength of soil and rock in the analysis. A factor of safety is applied to the factors that affect the sliding stability and are known with the least degree of certainty; these factors are the material strength properties.

A state of limiting equilibrium is said to exist when the resultant of the applied shear stresses is equal to the maximum shear strength along a potential failure surface. Therefore, a structure is stable against sliding for a potential failure surface when the applied shear stress is less than the available shear strength along that surface. The ratio of the maximum shear strength to the applied shear stress along a potential failure surface is defined as the factor of safety (FS) as shown in Equation 1.

$$FS = \frac{\tau_F}{\tau} \quad (1)$$

where

τ_F = maximum shear strength

τ = applied shear stress

By rearranging Equation 1, the shear stress necessary to maintain the wedge system in equilibrium is equal to the maximum shear strength divided by the factor of safety (Equation 2).

$$\tau = \frac{\tau_F}{FS} \quad (2)$$

This ratio or maximum shear strength to FS may be thought of as the degree of shear strength mobilized.

Assumptions and Simplifications of Analysis

Two simplifications used in the derivation of the sliding equations are as follows:

- a. The interface between adjacent wedges is a vertical plane.
- b. The failure surface is composed of linear segments.

The fundamental assumptions used in the derivation of the sliding equations are as follows:

- a. The FS is defined by Equation 1.
- b. The sliding mechanism can be adequately represented by a two-dimensional analysis.
- c. The maximum available shear resistance is defined by the Mohr-Coulomb failure criteria.
- d. The assumed failure surface is kinematically possible.
- e. Force equilibrium is satisfied; moment equilibrium is not considered.
- f. The shearing force acting parallel to the interface of any two wedges is negligible, and there is no interaction of vertical effects between wedges.
- g. The FS for each wedge is identical.
- h. The effects of displacements on the magnitudes of active and passive forces developed are not considered.
- i. There can be only one structural wedge because concrete structures transfer significant shearing forces.

Sign Convention

The equations for the sliding stability of a general wedge system are derived using a right-hand coordinate system as shown in Figure 4. The origin of each wedge is located at the lower left corner of the wedge as shown in Figure 5. The x-axis is horizontal, and the y-axis is vertical.

Axes that are tangent (t) and normal (n) to a failure plane are inclined at an angle (α) to the positive x- and y-axes. A negative angle is formed from a clockwise rotation of the axes. A positive angle is formed from a counterclockwise rotation of the axes.

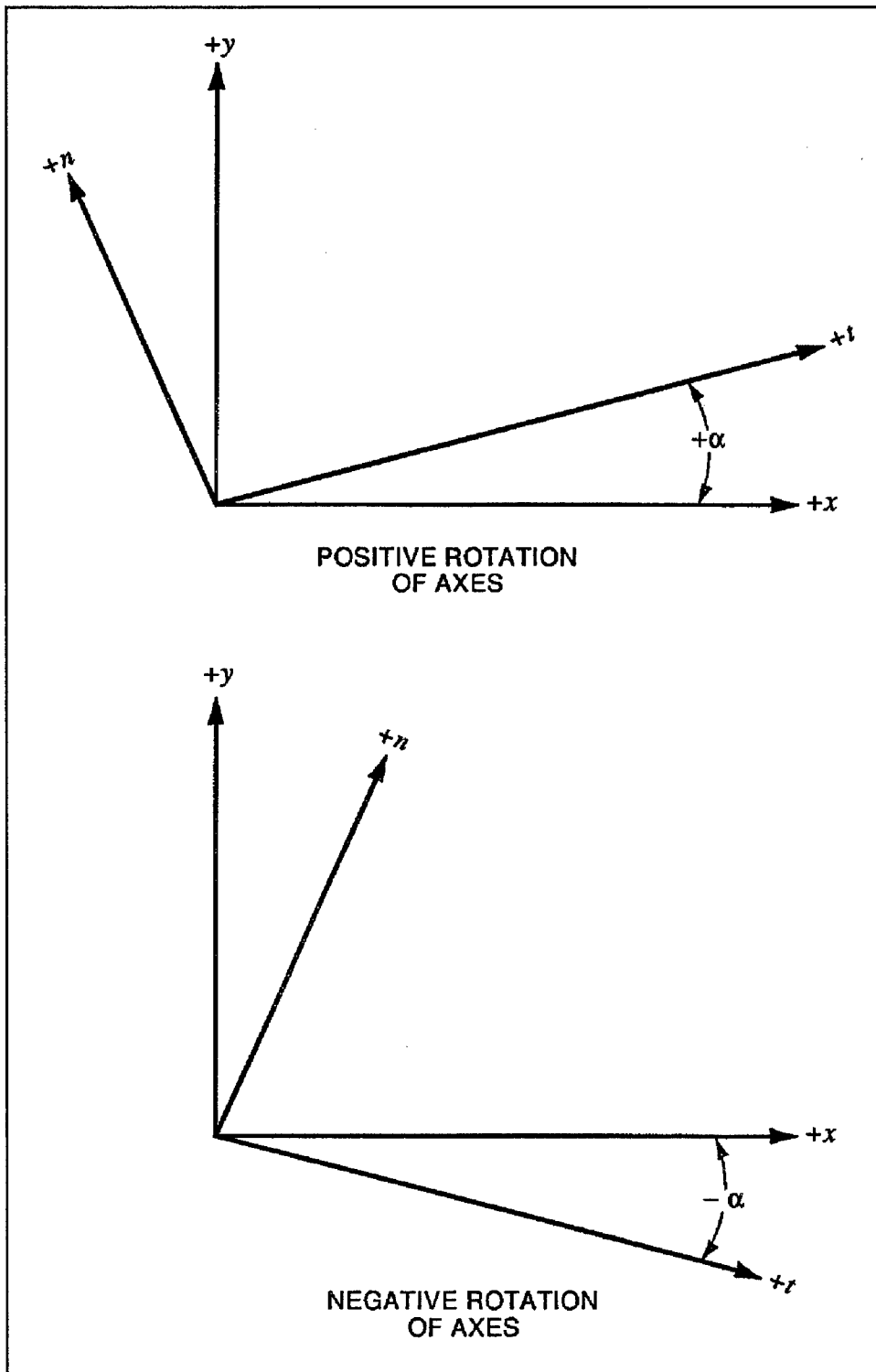

Figure 4. Sign convention

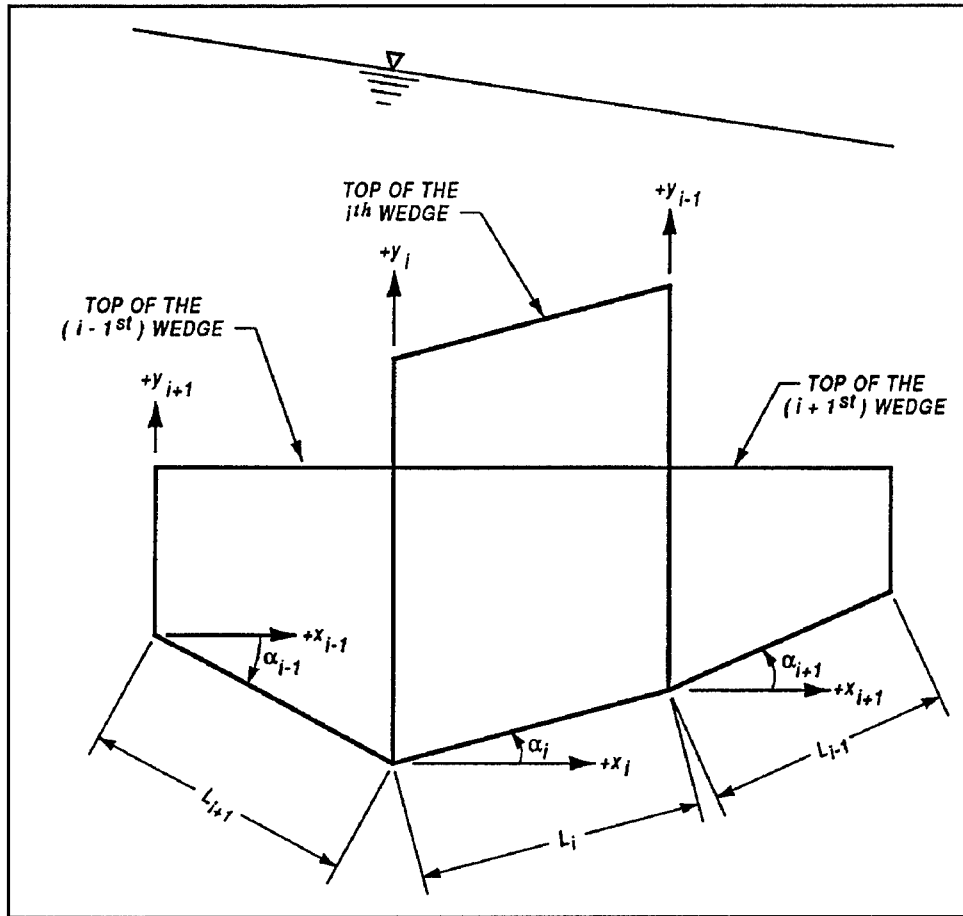

Figure 5. Geometry of typical i^{th} wedge and adjacent wedges

Figure 5 illustrates the sign convention and angle orientation for a typical i^{th} wedge.

Forces on Typical Wedge

The forces acting on a wedge may be applied by external loads to the wedge system or by internal loads within the wedge system. Internally applied loads consist of the weights of the wedges and the contact boundary forces that exist between adjacent wedges. All other applied loads are considered external loads.

Figure 6 illustrates the possible loads that can exist on a typical i^{th} wedge. Except for the P and W forces, all other forces applied to the wedge in Figure 6 are external loads. The P forces include the effects of water forces and earth forces that exist at the interface of adjacent wedges.

The presence of water may also induce external horizontal and vertical loads if the water level is above the top of a wedge or above the top of an adjacent wedge.

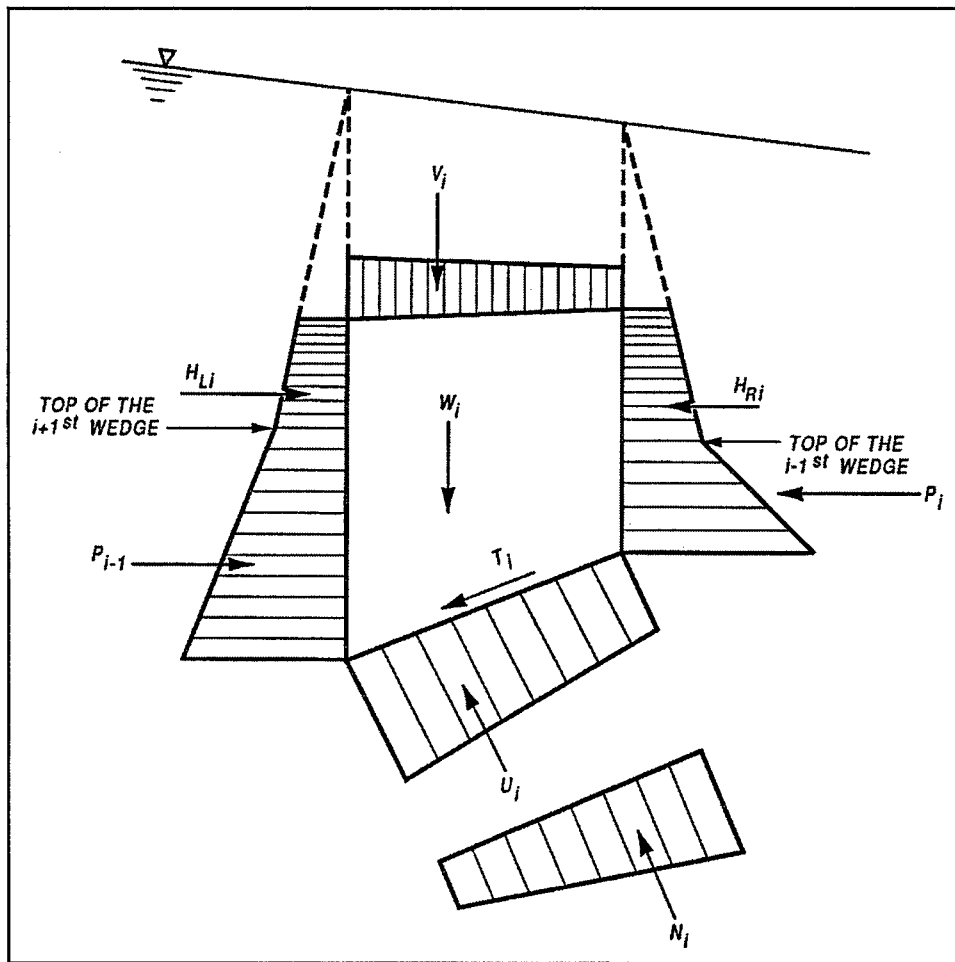

Figure 6. Distribution of pressures and resultant forces acting on a typical wedge

Listed below are the various loads that can exist on a typical wedge:

- a. The V forces consist of applied surcharge loads, induced loads because of earthquake accelerations, and water loads.
- b. The H forces consist of applied point loads, induced loads because of earthquake accelerations, and water loads.
- c. The W force is the weight of the wedge.
- d. The P forces are the earth forces and water forces that exist between adjacent wedges.
- e. The U force is the resultant uplift force because of seepage or hydrostatic pressures.
- f. The T force is the applied shearing force.

- g. The N force is the normal force necessary for the wedge to remain in equilibrium.

Derivation of Governing Wedge Equation

The initial step in the derivation of the governing wedge equation is to sum forces in the tangential and normal directions as seen in EC 1110-2-291. To accomplish this, the free body diagram must be drawn and the applied forces resolved into their normal and tangential components as shown in Figure 7. Only force equilibrium is satisfied in this procedure; moment equilibrium is not considered. Therefore, only the magnitudes of the applied forces are considered and not their locations. Summing forces in the normal direction provides the equation for the normal force.

$$\begin{aligned}
 \sum F_n &= 0 \\
 0 &= N_i + U_i - W_i \cos \alpha_i - V_i \cos \alpha_i - H_{L_i} \sin \alpha_i \\
 &\quad + H_{R_i} \sin \alpha_i - P_{i-1} \sin \alpha_i + P_i \sin \alpha_i \\
 N_i &= (W_i + V_i) \cos \alpha_i - U_i + (H_{L_i} - H_{R_i}) \sin \alpha_i \\
 &\quad + (P_{i-1} - P_i) \sin \alpha_i
 \end{aligned} \tag{3}$$

Next, summing forces in the tangential directions provide the equation for the applied shearing force.

$$\begin{aligned}
 \sum F_t &= 0 \\
 0 &= -T_i - W_i \sin \alpha_i - V_i \sin \alpha_i + H_{L_i} \cos \alpha_i - H_{R_i} \cos \alpha_i \\
 &\quad + P_{i-1} \cos \alpha_i - P_i \cos \alpha_i \\
 T_i &= (H_{L_i} - H_{R_i}) \cos \alpha_i - (W_i + V_i) \sin \alpha_i \\
 &\quad + (P_{i-1} - P_i) \cos \alpha_i
 \end{aligned} \tag{4}$$

The limit equilibrium analysis considers a material to be on the verge of failure. The maximum shear strength of a material is assumed to be defined by the Mohr-Coulomb failure criteria as shown in Figure 8. Thus, the maximum shearing force available to resist sliding along the base of a wedge is defined by the Mohr-Coulomb failure criteria as

$$T_F = N_i \tan \phi_i + c_i L_i \tag{5}$$

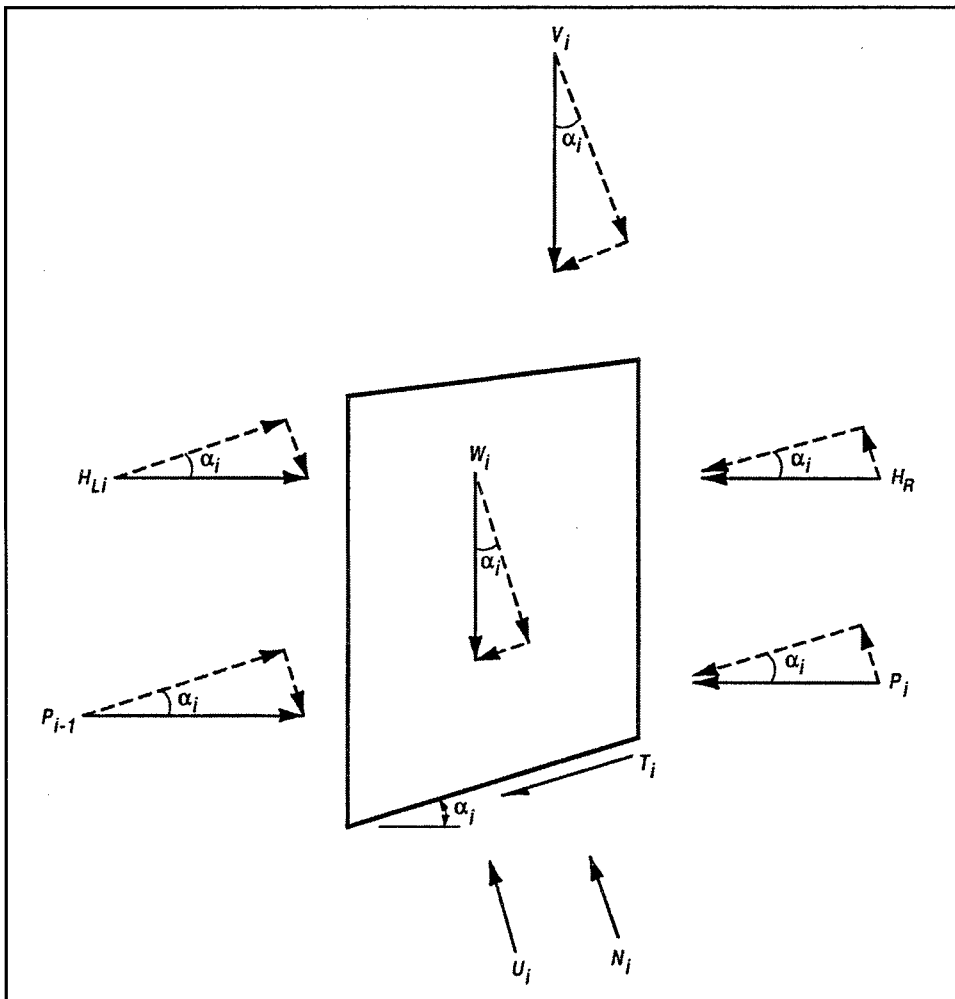

Figure 7. Free body diagram of i^{th} wedge

where

T_F = maximum shearing force available to resist sliding

N_i = applied normal force on base of i^{th} wedge

ϕ_i = internal friction angle of soil along base of i^{th} wedge

c_i = average cohesion of soil along base of i^{th} wedge

L_i = length of the base of i^{th} wedge

The governing wedge equation can now be derived by combining the definition of the FS with the definition of the maximum shearing force along the base of a wedge as defined by the Mohr-Coulomb failure criteria. By combining Equations 1 and 5, the FS is now equal to

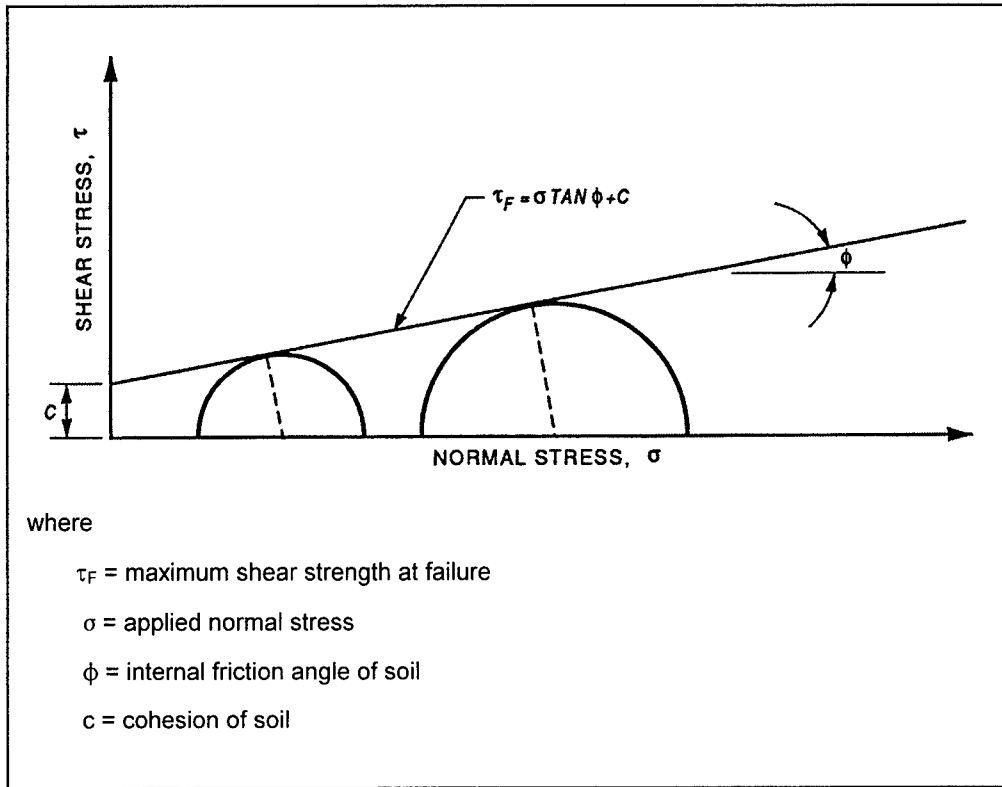

Figure 8. Mohr-Coulomb failure criteria

$$FS_i = \frac{T_F}{T_i} = \frac{N_i \tan \phi_i + c_i L_i}{T_i} \quad (6)$$

Inserting the equation for the normal force (Equation 3) and the equation for the applied shearing force (Equation 4) into Equation 6 yields an equation for the FS in terms of the forces applied to an individual wedge.

$$FS_i = \frac{(W_i + V_i) \cos \alpha_i - U_i + [(H_{L_i} - H_{R_i}) + (P_{i-1} - P_i)] \sin \alpha_i \tan \alpha_i + c_i L_i}{[(H_{L_i} - H_{R_i}) + (P_{i-1} - P_i)] \cos \alpha_i - (W_i + V_i) \sin \alpha_i} \quad (7)$$

Rearranging Equation 7 to solve for the net internal wedge force, $P_{i-1} - P_i$, yields the governing wedge equation for an individual wedge.

$$P_{i-1} - P_i = \frac{[(W_i + V_i) \cos \alpha_i - U_i + (H_{L_i} - H_{R_i}) \sin \alpha_i] \frac{\tan \phi_i}{FS_i} - (H_{L_i} - H_{R_i}) \cos \alpha_i + (W_i + V_i) \sin \alpha_i + \frac{c_i}{FS_i} L_i}{\cos \alpha_i - \sin \alpha_i \frac{\tan \phi_i}{FS_i}} \quad (8)$$

Equation 8 is the form of the governing wedge equation implemented in CSLIDE and discussed in the remainder of this report.

A negative value of the difference, $P_{i-1} - P_i$, indicates the applied shearing forces acting on the i^{th} wedge exceed the shearing forces resisting sliding along the base of the wedge. A positive value of the difference, $P_{i-1} - P_i$, indicates the applied shearing forces acting on the i^{th} wedge are less than the shearing forces resisting sliding along the base of the wedge.

The assumed direction of the applied shearing force T_i implies failure is occurring from left to right. Because of this assumption, the active earth force side is located to the left of the structural wedge, and the passive earth force side is located to the right of the structural wedge.

In the remainder of this report, any reference to the sign of a force, as it relates to the direction of failure, will be based upon the assumption that failure will occur from left to right.

The governing wedge equation has two unknowns: the difference, $P_{i-1} - P_i$, and the FS. For a system with a total of n wedges, there will be $2n$ unknowns. Recall, one of the assumptions of this method is the system of wedges act as an integral failure mechanism. For this to be true, the safety factors for all the wedges must be identical. Thus, for a system of n wedges, there will be n equations with $n + 1$ unknowns.

An additional equation is supplied by satisfying overall horizontal equilibrium, $\Sigma F_H = 0$, for the entire system of wedges.

$$\sum_i^n (P_{i-1} - P_i) = 0 \quad (9)$$

where the boundary forces P_0 and P_n are set equal to zero.

Usually an iterative process is required to determine the FS that places the system of wedges in equilibrium. The net horizontal earth force, $P_{i-1} - P_i$, for each wedge is calculated using Equation 8 with a trial FS. All of the $P_{i-1} - P_i$ forces are summed, and if Equation 9 is satisfied, the FS is obtained that places the system of wedges in equilibrium.

4 Analysis Procedure

General Iteration Procedure

Procedure for a fixed failure surface

A general procedure for analyzing a system of wedges with predetermined base inclinations using the governing wedge equation is summarized below:

- a.* Assume a potential failure surface based on the geologic conditions of the foundation and configuration of the substructure.
- b.* Divide the assumed failure surface into the appropriate number of wedges with one structural wedge. The interface between adjacent wedges is defined by a vertical plane.
- c.* Isolate each wedge in a free body diagram, applying all forces that act on the wedge.
- d.* Assume an FS for the system.
- e.* Calculate the difference, $P_{i-1} - P_i$, for each wedge using the governing wedge equation.
- f.* Sum the differences, $P_{i-1} - P_i$.
- g.* For the system of wedges to be in equilibrium, the sum of the differences calculated in Step *f* should equal zero.
- h.* Based on the sum of the differences, revise the value of the assumed FS. If the sum is negative, the FS is lower than assumed. If the sum is positive, the FS is greater than assumed.
- i.* Repeat Steps *e* through *h* until equilibrium is achieved.
- j.* Other failure surfaces may be analyzed by returning to Step *a*.

The above procedure assumes the total failure surface is determined prior to performing the iterative procedure that finds the FS that produces a state of equilibrium.

Procedure for a variable failure surface

An alternate procedure is necessary when the failure surface is unknown. The failure surface is determined by assuming an initial FS and varying the inclinations of the bases of the wedges. The failure angle of each active wedge is varied to produce a maximum driving force, and the failure angle of each passive wedge is varied to produce a minimum resisting force. Once the failure surface is established, the interaction procedure is similar to the procedure for a fixed failure surface given in the previous section.

The general interaction procedure for obtaining the FS for a variable failure surface is given below:

- a. Assume an FS.
- b. Depending on the geologic conditions of the foundation and configuration of the substructure, predetermine any portions of the failure surface that are not variable. The starting elevations of the wedges adjacent to the structural wedge may also need to be predetermined.
- c. Beginning with the wedge *closest* to the structural wedge on the *active* side (Figure 9), choose a trial inclination for the base of this wedge. The wedge closest to the structural wedge will also be the wedge in the lowest soil layer.
- d. For this trial inclination, draw a free body diagram of the wedge applying all forces that act on the wedge.
- e. Calculate the difference, $P_{i-1} - P_i$, for the wedge.
- f. Assume a new trial inclination and repeat Steps *d* and *e*. Depending on whether or not the second trial inclination produced a larger or smaller difference (absolute value), vary the inclination until a *maximum* magnitude of the difference, $P_{i-1} - P_i$, is found.
- g. Move out from the structural wedge to the next wedge. The outer wedge will begin where the inner wedge ended. Repeat Steps *d* through *f*. Do this for all the active wedges.
- h. Draw a free body diagram of the structural wedge applying all forces that act on the wedge. Calculate the difference, $P_{i-1} - P_i$, for each wedge.
- i. Repeat Steps *c* through *g* for the wedges on the *passive* side except iterate to find a *minimum* magnitude of the difference, $P_{i-1} - P_i$, for each wedge.
- j. Sum up the $P_{i-1} - P_i$ differences. For the system to be in equilibrium, the sum should equal zero.
- k. If the sum of the differences does not equal zero, revise the value of the trial FS. If the sum is negative, the FS is lower than assumed; whereas, if the sum is positive, the FS is greater than assumed.

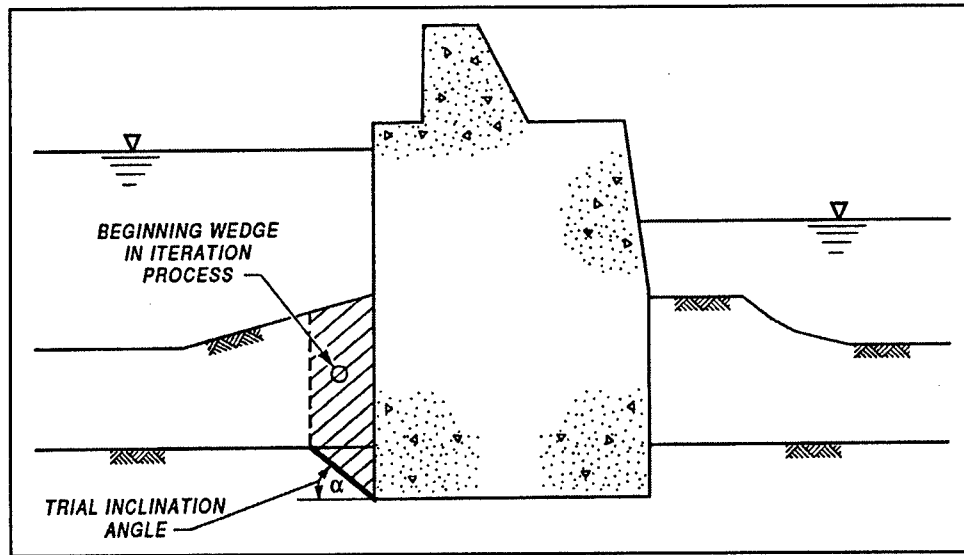

Figure 9. Beginning wedge in iteration process

- l. Repeat Steps *c* through *k* until the sum of the $P_{i-1} - P_i$ differences equals zero.

CSLIDE Procedure

CSLIDE uses the previously described iteration procedure for a variable failure surface to calculate the critical failure surface that has the minimum FS. The manner in which CSLIDE varies the FS and the failure angles of the wedges to locate this critical failure surface and minimum FS is described in this section. The convergence criteria employed by CSLIDE to indicate when the solution has converged to a critical one are also discussed in this section.

Factor of safety

CSLIDE uses an upper and lower bound for the FS to select a trial FS to be used in the first two iterations. An upper bound of 1.5 and a lower bound of 0.5 for the FS are the default values, but the user has the option to select his own values for the upper and lower bounds.

In the first iteration, the average of the upper and lower bounds is used as the trial FS. After the first iteration, if the sum of the $P_{i-1} - P_i$ differences is negative, the lower bound is used in the second iteration. If the sum of the $P_{i-1} - P_i$ differences is positive, the upper bound is used in the second iteration. For any subsequent iterations, a trial FS is extrapolated from or interpolated between the present and previous factors of safety to achieve a state of horizontal equilibrium.

For possible problems concerning the use of input values for the upper and lower bounds of the FS, refer to Chapter 5.

Failure angles

The base inclination angles for both the single- and multiple-plane analyses (Chapter 5) vary initially in 5-deg¹ increments. When a maximum or a minimum force for a wedge is bounded by two angles, the increment is reduced.

The failure angles for a single-plane analysis are calculated to the nearest 0.001 deg. The failure angles for a multiple-plane analysis are calculated to the nearest 0.1 deg to reduce the amount of computational work.

The single- and multiple-plane analyses differ in the accuracy used to calculate the failure angles. For a single-plane analysis, all wedges on a particular side, active or passive, will have the same failure angle. Therefore, a minimum resisting or a maximum driving force is sought for a particular plane and not for each individual wedge. For this analysis, the failure angles are calculated to the nearest 0.001 deg. For a multiple-plane analysis, the failure angle of each wedge is varied to find a maximum driving or minimum resisting force for that wedge. This analysis requires more computational work than does the single-plane analysis. Consequently, the failure angles for the multiple-plane analysis are calculated to the nearest 0.1 deg.

Convergence criteria

The solution is assumed to have converged when the absolute value of the sum of the $P_{i-1} - P_i$ differences for any iteration is less than or equal to 0.001 kips.

Water Pressures

The user may use any of the following methods to account for the uplift effects because of the presence of water:

- a. Water pressures may be entered at the ends of each wedge.
- b. Hydrostatic pressures may be calculated at the ends of each wedge.
- c. An uplift force may be entered for the structural wedge.
- d. Uplift pressures at the ends of each wedge may be calculated by the line of creep method.
- e. A drainage efficiency value may be entered to compute an uplift force normal to the base of the structural wedge.

¹ A table of factors for converting non-SI units of measurement to SI units is presented on page ix.

An explanation of each method is provided in the following paragraphs.

Input uplift pressures

Water pressures may be entered at the ends of each wedge, and the program will calculate an uplift force acting on the base of each wedge.

Hydrostatic pressures

Hydrostatic pressures will be calculated at the ends of each wedge if hydrostatic conditions exist or if the program is instructed to calculate hydrostatic pressures. The program will use the hydrostatic pressures to calculate an uplift force that acts on the base of each wedge.

Input uplift force

An uplift force that acts on the base of the structural wedge may be specified. The uplift forces on the remaining wedges may be calculated by any of the other methods.

Line of creep

Seepage pressures are calculated using the line of creep method. The line of creep method assumes a linear distribution of head loss along the shortest seepage path. The shortest seepage path is the distance in the soil around the wetted perimeter of the structural wedge.

Bernoulli's equation for laminar flow defines the total head (h) measured from an arbitrary datum as

$$h = z + \frac{P_w}{\gamma} \quad (10)$$

where

z = elevation head of an arbitrary point

P_w = pressure at an arbitrary point

γ = unit weight of water

In groundwater flow, the value of the total head changes from point to point in the soil medium because of a loss of energy due to the viscous resistance within the individual pores. To account for this loss of energy, Bernoulli's equation is taken as

$$z_1 + \frac{P_{w_1}}{\gamma} = z_2 + \frac{P_{w_2}}{\gamma} + h_L \quad (11)$$

where h_L is the head loss between points 1 and 2.

Referring to Figure 10, the pressure at an arbitrary point P may be calculated by using Equation 11. By taking the datum at the elevation of the tailwater, point 1 at the elevation of the headwater, and point 2 at point P, Equation 11 reduces to

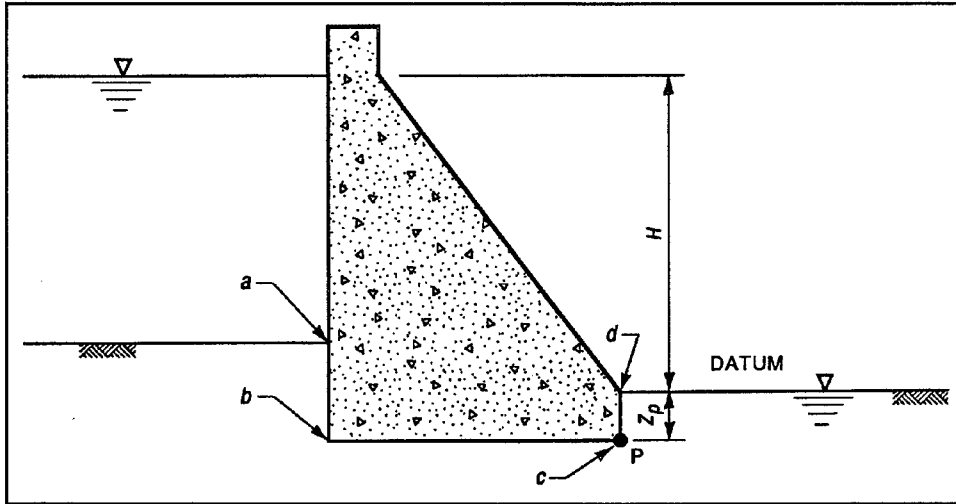

Figure 10. Pressure at an arbitrary point

$$H + 0 = -z_p + \frac{P_p}{\gamma} + h_{L_p} \quad (12)$$

$$P_p = (H + z_p - h_{L_p})\gamma$$

where

P_p = pressure at point P

H = total head loss, headwater elevation minus tailwater elevation

z_p = elevation head to point P, elevation of datum minus elevation of point P

h_{L_p} = total head loss incurred going to point P

The head loss to an arbitrary point P is calculated as

$$h_{L_p} = H \left(\frac{\text{Distance around wetted perimeter to point p}}{\text{Total seepage distance around wetted perimeter}} \right) \quad (13)$$

From Figure 10, the head loss incurred in going from point 1 to point 2 is

$$h_{L_p} = H \left(\frac{abc}{abcd} \right) \quad (14)$$

Drainage efficiency

When a value for drainage efficiency is entered, the equation used to calculate the uplift force (U) is defined in Wolff and Wang (1992) as:

$$U = \frac{1}{2} [2H_R + (1-E)(H_D - H_R)] B \gamma_w \quad (15)$$

where

H_R = height of water on resisting side above base of structure

E = drainage efficiency

H_D = height of water on driving side above base of structure

B = width of base

γ_w = unit weight of water

Limitations of Program

The main limitation of the program is the restriction that the number of wedges formed must equal the number of soil layers. As discussed earlier in the procedure for a variable failure surface, a wedge is first formed in the lowest soil layer on each side of the structural wedge, and the base on a wedge is contained entirely in a single soil layer. The program progresses up the soil layers until a wedge is formed in the top soil layer.

Once the base of a wedge has been established in a soil layer, the remaining soil profile beyond the base of the wedge is ignored. The program does not realize when the base of a wedge in an upper soil layer intersects a lower soil profile. This is shown in Figure 11.

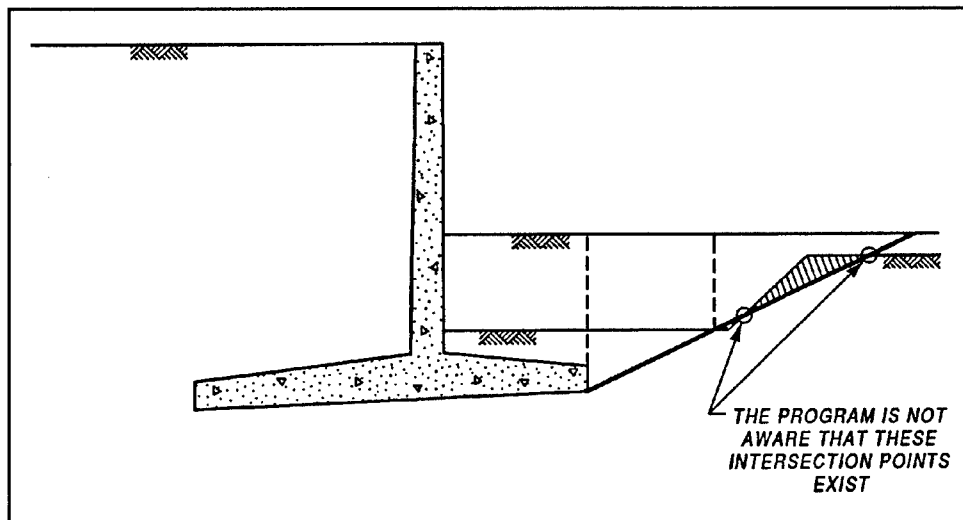

Figure 11. Conflict of wedge in upper soil layer with lower soil layer

Another restriction of the program is that no portions of one soil profile may coincide with another soil profile. All soil profiles must be separated by some small distance. An example of how to model a problem which has a conflict with overlapping layers is shown in Figure 12.

Since CSLIDE uses the governing wedge equation as derived earlier, failure is assumed to occur from left to right. The iteration procedure contained in CSLIDE is also based upon this assumption. Therefore, when entering a problem, the active side must always be on the left, and the passive side must always be on the right.

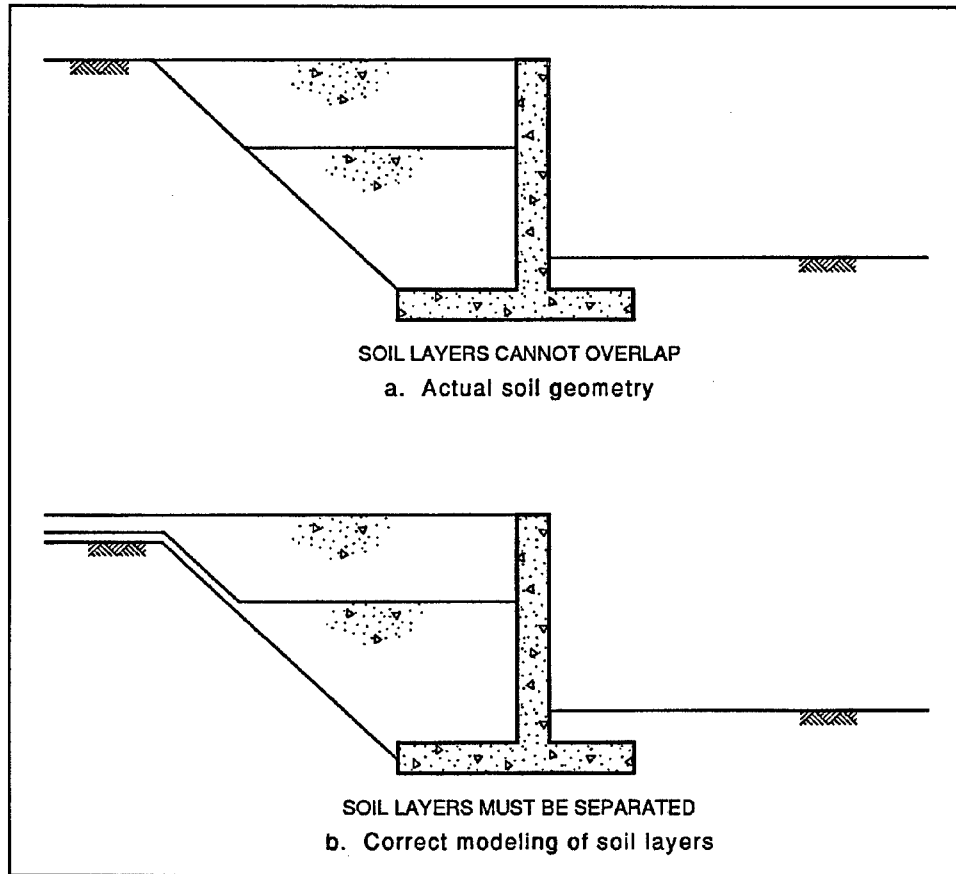

Figure 12. Modeling several overlapping soil layers

5 CSLIDE Input Terminology

This section will elaborate upon some of the terminology used in program input options. The purpose of each term, the conditions that warrant its use, and the information required for its use will be discussed.

Factor of Safety Ratio

The user is allowed to enter a ratio of the FS for the passive side to the FS for the active side. The program will try to maximize the active earth force using a trial FS. Once the active earth force is maximized, the trial FS is multiplied by the ratio entered. The program then uses this new FS in an attempt to minimize the passive earth force.

The movement of the soil required to develop a full passive earth force is about 5 to 10 times the movement required to develop a full active earth force. Since a maximum driving force will exist before the full resisting force is developed, it would be desirable to use only a partial amount of the full passive resistance in an analysis. By applying a greater FS to the passive wedges than that applied to the active wedges, the passive resistance may be reduced. This is accomplished by using an FS ratio greater than one.

For an FS ratio of one, both the active and passive wedges will use the same trial FS. When a state of equilibrium is obtained, the active FS and passive FS will be equal. The value of the FS when the failure mechanism is in equilibrium for an FS ratio of one will be called the balance point, as shown in Figure 13.

Figure 13 demonstrates how an increase in the passive FS will result in a corresponding decrease in the active FS, and a reduction in the passive FS will produce an increase in the active FS. This is the typical trend of the active and passive factors of safety for equilibrium conditions.

A linear relationship does not exist between the FS ratio and the value of the active FS. If results were compared for FS ratios of 2 and 10, the active FS obtained would not differ by a factor of 5. This can be seen from the shape of the curve in Figure 13.

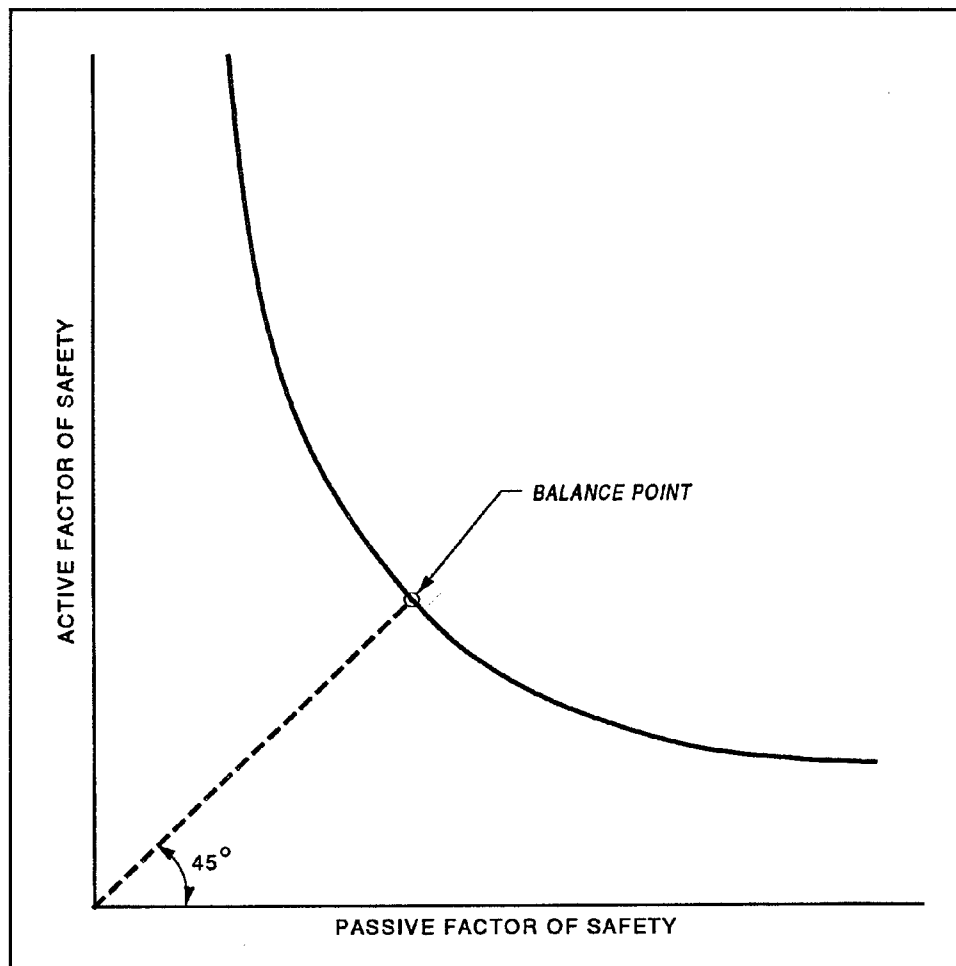

Figure 13. Relationship of passive to active factors of safety for equilibrium conditions

Also, a linear relationship does not exist between the passive FS and the forces exerted by the passive wedges. The passive FS may be increased by a certain factor, but the passive earth forces would not decrease by this same factor.

Since the reduction of the passive earth forces is the primary concern, the $P_{i-1} - P_i$ forces acting on the passive wedges obtained for a particular FS ratio should be compared with the passive forces obtained when the FS is equal to one and full passive earth forces are produced. By comparing the passive forces obtained for various FS ratios to the passive forces obtained for an FS of one, the actual decrease in the passive resistance may be measured.

Active Wedge-Structure Intersection Elevation

Depending upon the condition and the type of foundation material, the starting elevation of the active wedge adjacent to the structural wedge may need to

be adjusted. Initially, the starting elevation of this wedge is assumed to be at the elevation of the lower left corner of the structure. If needed, the user has the option to change this starting elevation.

If the structure is founded in competent rock, the rock will not exert an active force on the structure when the structure begins to move. Therefore, the failure plane on the active side should begin at the top of the rock foundation. If water exists above the base of the structure, the horizontal component of the water load on the structure below this wedge elevation should be included in the analysis as an external load, because it is not included in the interslice forces. An example of this is shown in Figure 14.

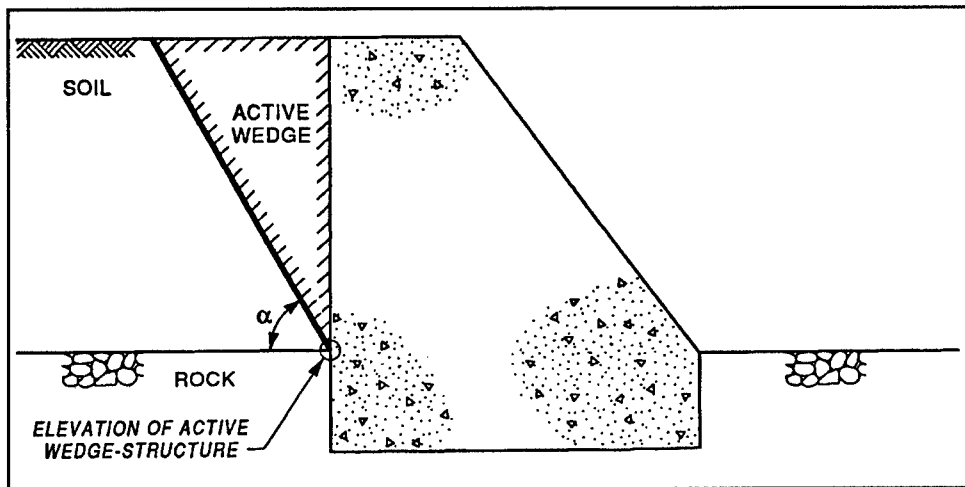

Figure 14. Elevation of active wedge-failure angle at left side of structure

Input Wedge Angles

The inclination of the failure planes may be predetermined by factors such as loading conditions and the geologic structure of the foundation. The failure angle of any wedge may be specified to account for these conditions.

A condition that warrants the user determining the inclination of a failure plane would be a structure founded in rock that has discontinuities such as bedding planes.

Factor of Safety Boundaries

CSLIDE uses an upper and lower bound to select the trial FS to be used in the first two iterations in search of a critical failure surface. Initially, the upper boundary for the FS is set to 1.5, and the lower boundary is set to 0.5. The program begins the iteration process with the average of the upper and lower boundaries. Depending on whether the sign of the sum of the forces on the system is negative or positive, the lower or upper boundary is used, respectively, for the next iteration.

For each iteration afterward, a new trial FS is computed by extrapolating from or interpolating between the present and previous factors of safety to produce horizontal equilibrium.

The user may set an upper and lower boundary for the FS. This is often done when the final FS is known approximately, in order to eliminate excessive oscillations and cause the solution to converge more rapidly.

The user may also want to adjust the FS boundaries for other reasons. The solution process will halt if either the solution has not converged within 30 iterations, an FS greater than 100 is computed, or a trial FS less than or equal to 0.2 is computed. By shifting the boundaries of the FS, these conditions might be eliminated and a final solution obtained.

If the same value is entered for both the upper and lower boundaries of the FS, results are reported for that value of the FS. This feature is used to obtain the earth forces for a particular FS.

Percent of Base in Compression

For some load cases, the vertical component of the resultant applied loads will lie outside the kern of the base area. When this happens, a portion of the structural wedge will not be in contact with the foundation material. CSLIDE allows the user to control the percent of the base of the structure that is in compression to reflect the interaction between overturning and sliding behavior.

Therefore, it may be advantageous to perform an overturning analysis prior to the sliding analysis. From the overturning analysis, the uplift force on the base of the structure and the percent of the base in compression may be calculated.

The reduction of the contact length between the base of the structure and the foundation material reduces the adhesive force resulting from the contact between these two surfaces. The frictional resistance between the base of the structure and the foundation material is unaffected by the reduction in the base contact length.

Seismic Loading

Earthquake acceleration may be accounted for by using the seismic coefficient (pseudostatic) method. Both horizontal and vertical seismic coefficients are multiplied by the total weight of a wedge. The resulting horizontal and vertical loads are applied to the wedge as additional static loads.

The total weight of a wedge includes the weight of all soil contained in the wedge, all vertical surcharge loads applied to the wedge, and the weight of any water contained within the wedge.

When water is above ground, the static pressure that it exerts against a wall can be increased or decreased by seismic action. The force exerted by water above ground because of seismic action may be accounted for by using Westergaard's equation found in EM 1110-2-2200. The forces developed must be applied by the user as horizontal loads.

Guidance for the selection of appropriate values of the horizontal seismic coefficient may be found in Engineer Regulation (ER) 1110-2-1806. As stated in EC 1110-2-291, the vertical earthquake acceleration is normally neglected, but if included in the analysis, it can be taken as two-thirds of the horizontal coefficient.

Single-Plane Failure Analysis

A single-plane analysis uses a single plane on both the active and passive sides as shown in Figure 15. Since a single-failure plane is formed on each side of the structural wedge, one failure angle will be associated with the active wedges, and another failure angle will be associated with the passive wedges.

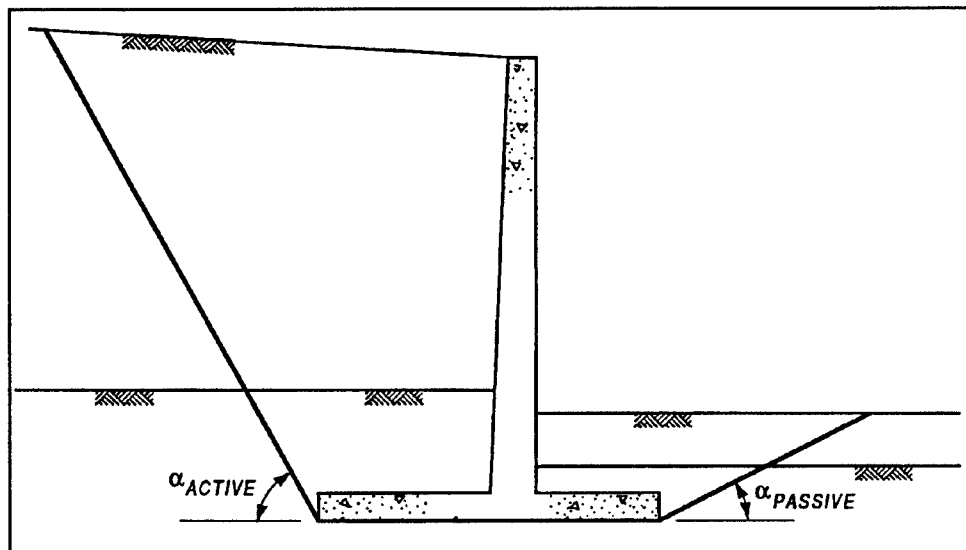

Figure 15. Single-plane failure analysis

Multiple-Plane Failure Analysis

As shown in Figure 16, a multiple-plane failure analysis forms a failure surface on both the active and passive sides of the structural wedge, which is composed of segments with varying failure angles. A different failure plane is formed in each soil layer. The inclination of the failure plane depends on the soil properties associated with that segment of the failure surface and on the loading conditions of the system.

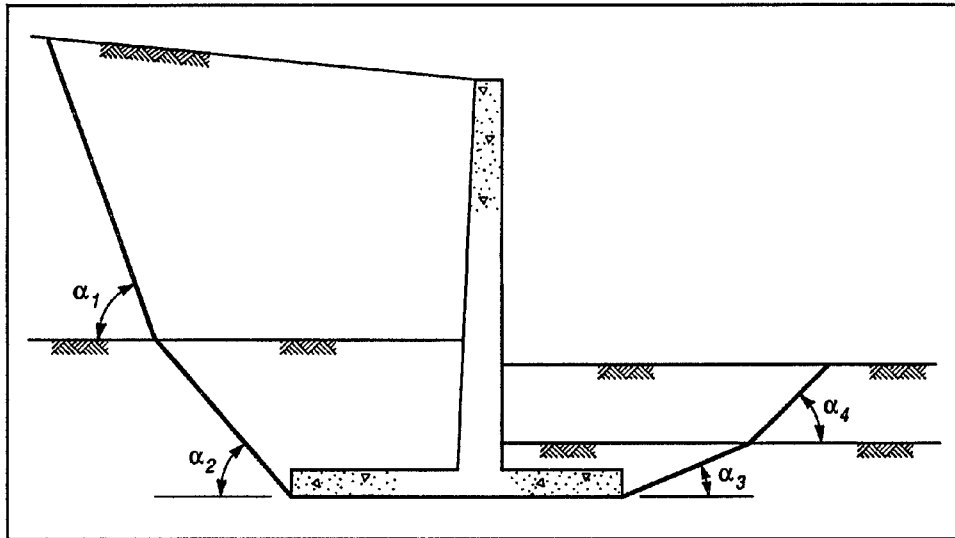

Figure 16. Multiple-plane failure analysis

The shear strength of a failure surface is a combination of the shear strengths of the individual wedges that form the failure surface. The shear strength of each segment of the failure surface is calculated using the soil properties of the soil layer in which the segment is contained.

For a system with a single soil layer, the multiple-plane failure analysis will yield results identical to those obtained by the single-plane failure analysis.

6 CSLIDE Output Terminology

This section discusses each item given in the program output file. The horizontal forces applied to both the left and right sides of each wedge and the vertical forces applied to each wedge are discussed. The individual components that comprise each load are presented. Other pertinent information required to perform a hand check of the computations, such as the failure angle, weight and length of each wedge, and the uplift force applied to each wedge, is also covered.

Horizontal Loads

The horizontal loads applied to both the left and right sides of each wedge are printed in the output file. Each value will be the summation of any input external horizontal loads, any horizontal load because of the presence of water next to the wedge, any horizontal load due to anchors, and any induced horizontal load because of horizontal earthquake acceleration.

The horizontal loads are always printed as positive values. Loads on the left side act toward the right, and loads on the right side act toward the left.

Vertical Loads

The vertical loads printed will be the summation of any applied vertical loads, any vertical load because of the presence of water above the wedge, any vertical load due to anchors, and any induced vertical load because of vertical earthquake acceleration.

A structural wedge may have an additional load because of soil contained within the structural wedge. Any soil contained above the base of the structure is reported as a vertical load.

If an input angle is applied to the structural wedge to shift the base of the structural wedge downward, the soil included in the structural wedge below the base of the structure is also reported as a vertical load.

Water Pressures

Water pressures are printed at the vertices of each wedge. As discussed in Chapter 4, these pressures may be entered by the user or calculated by the program. The program calculates hydrostatic water pressures or water pressures using the line of creep. If an uplift force was entered on the structural wedge, the uplift value will be reported.

Failure Angles

Failure angles, which may be entered by the user or calculated by the program, are printed for each of the wedges. For a single-plane failure analysis, these angles are calculated to the nearest 0.001 deg, while those for a multiple-plane failure analysis are calculated to the nearest 0.1 deg to reduce the amount of computations required.

Length of Wedge

Both the total length and the submerged length of each wedge are printed. The total length is used when calculating the weight of a wedge, and the submerged length is used when calculating the uplift force on a wedge.

Weight of Wedge

The weight of each wedge, except the structural wedges, includes only the weight of the soil contained within the wedge. The weight of the structural wedge consists only of the weight of the structure and does not include the weight of any soil contained within the structural wedge.

Uplift Force

The uplift force for each wedge is reported and includes the uplift effect because of water along the submerged length of the wedge. The user may enter an uplift force on the structural wedge instead of allowing CSLIDE to calculate pressures.

Net Force

The net force for each wedge is reported and is an indication of whether the wedge exerts a driving or resisting force. A negative net force implies the forces tending to cause sliding are greater than the forces resisting sliding; whereas, a positive net force indicates the forces tending to cause sliding are less than the forces resisting sliding.

The program assumes the active side is always on the left and the passive side is always on the right. An active wedge will have a negative net force, and a passive wedge will have a positive net force.

There are conditions, such as applying a horizontal earthquake load, that may cause the sign of the net force on passive wedge to be negative. In effect, this means the passive wedge is pulling on the remaining wedges. When this condition occurs, the net force on the passive wedge is set to zero in the program, and a message is printed. By setting the net force of the passive wedge to zero, any driving force exerted by the passive wedge is ignored.

Sum of Forces

The sum of the net forces on each wedge should equal zero if the system is in equilibrium. The program has a tolerance of 0.001 kip for this sum. There are several cases where the final solution will have a nonzero sum of the net forces. These conditions are discussed in the Possible Solutions section of this chapter.

A negative sum implies that the final FS will be less than the present one, while a positive sum implies that the final FS will be higher than the present one.

Factor of Safety

The solution has converged to a final FS when the absolute value of the sum of the net forces on each wedge is less than or equal to 0.001 kip. This will be the minimum FS, and the failure surface calculated will be the most critical one.

The calculated FS must be greater than 0.2 and less than 100. If a trial FS does not lie between these bounds, the iteration procedure will halt, and the results of the last completed iteration will be given as the final results.

If a large value for the FS is obtained, the active and passive sides of the problem should be reversed and the problem reanalyzed. A large FS may indicate sliding is in the opposite direction from what was originally assumed. Allowable factors of safety are given in EC 1110-2-291.

Output Messages

There are several informative messages that may appear in the output table. These messages refer to the following conditions:

- a. If an input angle is used for the structural wedge, a message will be printed giving the intersection point of the line inclined along this angle, with the opposite end of the structural wedge.

- b.* If, in the iteration process, the value of a failure angle for any wedge falls below -85 or exceeds +85 deg, the failure angle is fixed at ± 85 deg. A message is printed that identifies the angle or angles.
- c.* If, in the iteration process, a failure plane cannot be formed in a soil layer without exceeding the boundaries of the problem, a message is printed identifying the wedge or wedges in which this occurs. The end of the wedge is fixed at the outer boundary of the problem.

Possible Solutions

The final FS reported may be for one of the five following conditions:

- a.* If a trial FS drops below 0.2, a message is printed, and the results are reported for the last completed iteration.
- b.* If a trial safety factor goes above 100, a message is printed, and the results for the last completed iteration are reported.
- c.* If the solution does not converge within 30 iterations, a message is printed, and the results of the last iteration are reported.
- d.* If the solution converges within 30 iterations, the results of the final analysis are reported.
- e.* If the sum of the forces for any two successive iterations does not vary by more than 0.001 kip, the message "Stationary Solution" is printed. This message will occur if the upper and lower boundaries of the FS are equal.

If either *a*, *b*, or *c* occur, and the user changes the FS boundaries as discussed in Chapter 5, the program might then calculate a final FS.

7 Getting Started with RCSLIDE/CSLIDE

Installation

To install RCSLIDE in Windows 95/98, Windows NT Workstation 4.0 or later version

- 1 Insert the first Setup disk (Disk 1) into floppy drive.
- 2 Click the Windows **Start** button, click **Settings**, and then click **Control Panel**.
- 3 Double-click Add/Remove Programs.
- 4 On the **Install/Uninstall** tab, click **Install**.
- 5 Follow the instructions on the screen.

Minimum Program Requirements

- 1 Microsoft Windows 95 or later.
- 2 VGA monitor running 256 colors.
- 3 At least 4 MB of available hard disk space.

RCSLIDE Overview

RCSLIDE is designed to perform a reliability assessment of the sliding stability of concrete gravity structures. The Windows version of RCSLIDE includes a graphic interface that allows the user to create and edit the input files essential to performing an analysis. In addition, the program provides a graphical view of the concrete structure and the analysis results.

RCSLIDE is started by selecting the **Start** button, then **Programs**, then the CASE program choice, and finally **RSCLIDE**.

If the **Cancel** button is selected on any input screen, newly entered data on the current screen will not be incorporated into the program data file, and execution of the program will return to the previous window. Also, the last line or two of some of the windows is a message or status line(s).

When the program runs for the first time, the application presents the set run options window shown in Figure 17.

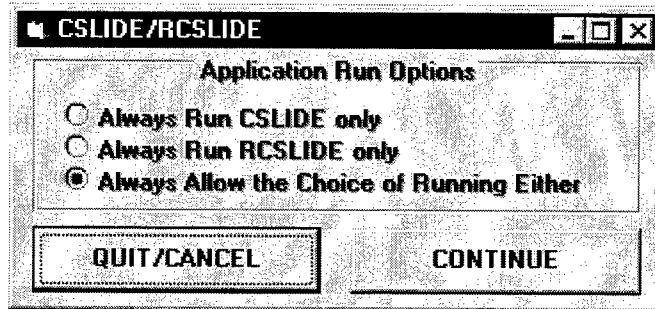

Figure 17. Set Run Options dialog box

These options specify how the application should start for future analysis. Choosing:

CSLIDE – Provides the user with input options necessary to run the CSLIDE module only.

RCSLIDE – Provides the user with input options necessary to run both the CSLIDE module and reliability assessment part of RCSLIDE.

Choice – Ask the user whether to execute the CSLIDE module or RCSLIDE as shown in Figure 18 (DEFAULT).

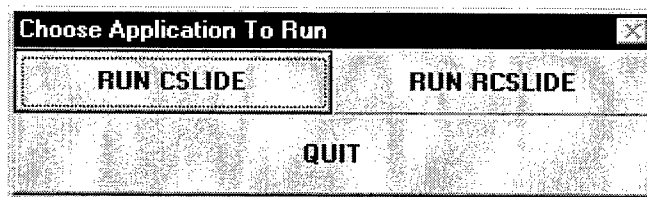

Figure 18. Application Choice dialog box

This option may be changed later by selecting the **Set Run Options** from the **File** menu as described later in this chapter.

Title Screen

When the user selects to execute RCSLIDE or CSLIDE, the appropriate main menu or title screen will be displayed as shown in Figures 19 and 20.

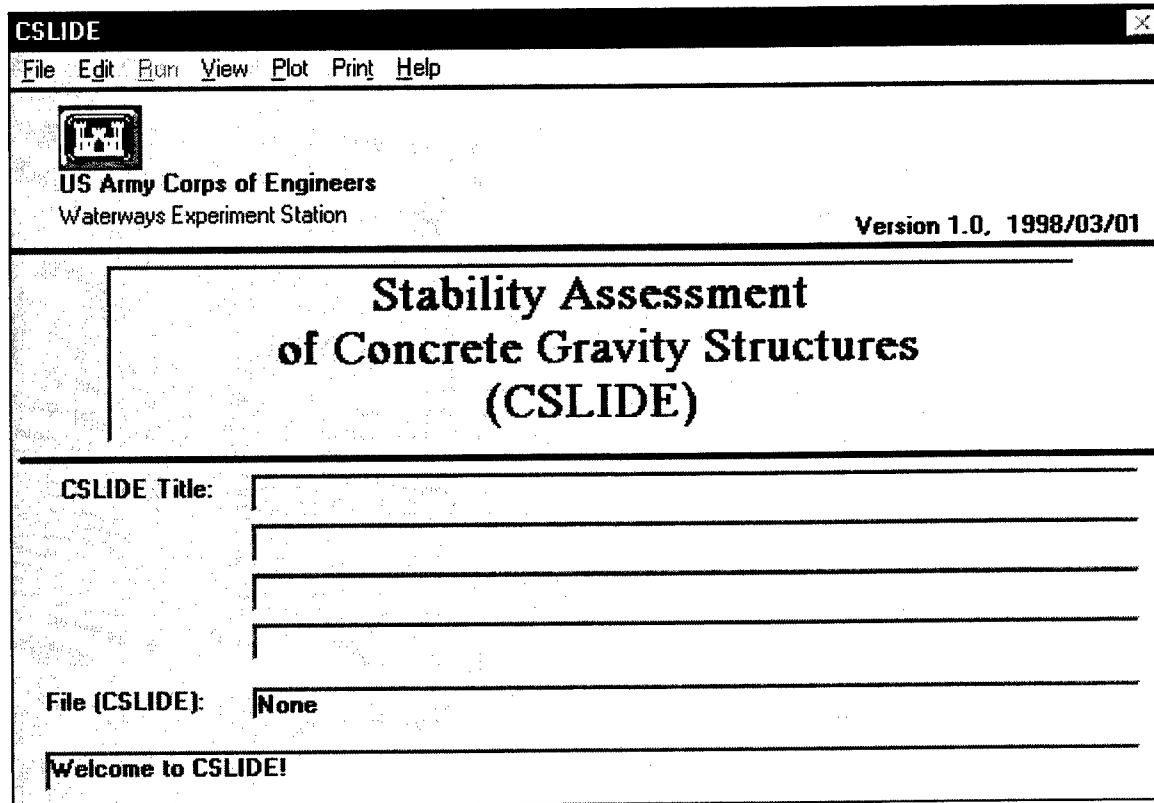

Figure 19. CSLIDE title screen

CSLIDE, a unit module of the RCSLIDE application, is used to assess the sliding stability of concrete structures. Users may use this section of the RCSLIDE application to produce the data file necessary to perform a reliability assessment or if desired to only execute CSLIDE.

RCSLIDE is used to perform a reliability assessment of the sliding stability for a particular structure. The RCSLIDE main window is very similar to the one in the CSLIDE module. However, some of the menu options and data entry forms have additional features that make a reliability analysis possible, which are described in Chapter 9.

Menu bar

These title screens possess a common menu bar with the following options:

File. Provides options to open, save, remove, and create new files. It allows the user to change how the application runs, supplies the means for printing several of the program's associated files, and furnishes the ability to terminate the program.

Edit. Can be used to produce the input files and edit an existing input file. A detailed explanation of input files and the process for entering and editing them will be discussed in Chapter 8.

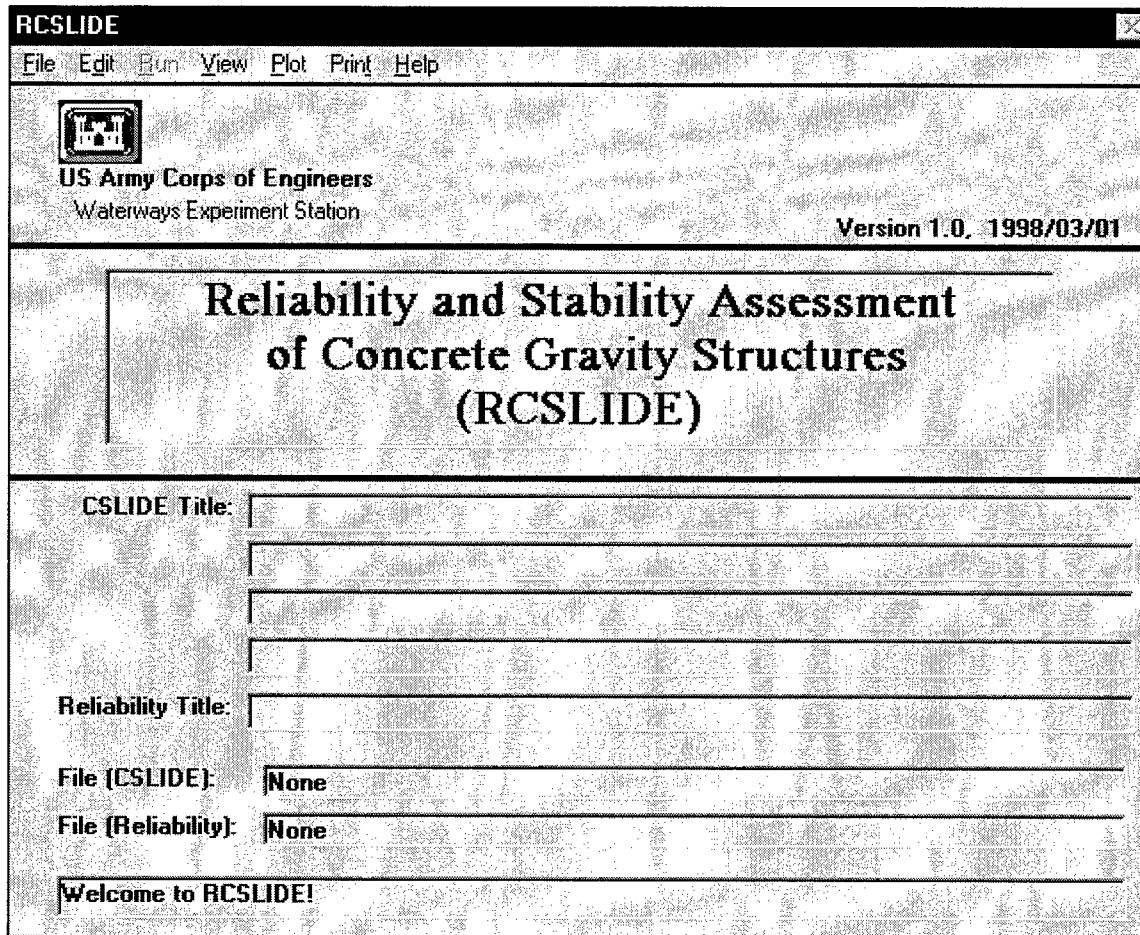

Figure 20. RCSLIDE title screen

Run. Displays each application's analysis window.

View. Displays the associated text input and output files. An example of the view command to display an output file is shown in Figure 82 in Chapter 10.

Plot. Provides a pictorial representation of the structure under investigation and a plot of each wedge with all forces applied. The RCSLIDE application provides an additional feature that allows the user to plot simulation results. A plot example is shown in Figure 87 of Chapter 10.

Print. Allows the user to print the current screen.

Help. Provides information to assist the user in operating the program through a text format help-manual that describes the syntax and format for input files and contains descriptions of the program's data entry fields. The Help menu, Figure 21, allows access to the complete help system. For windows accessed through the Edit and Run menu options, the application displays content specific help. This option is currently being enhanced using a Windows-based format.

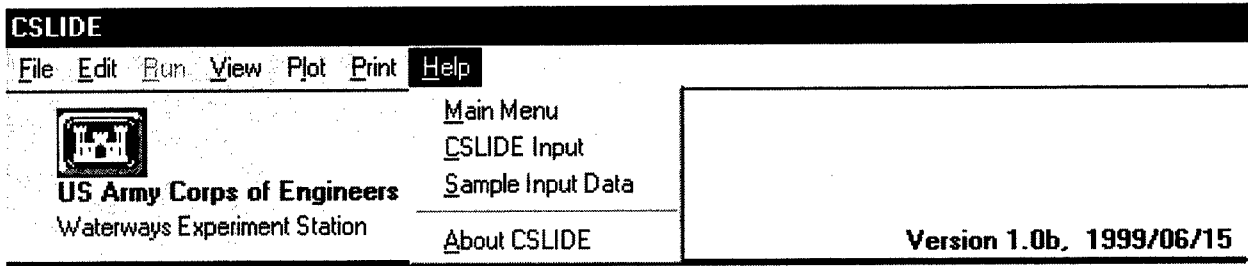

Figure 21. Help menu

Title/Heading

A problem title that is printed in the output file's heading may be entered here as described in Chapter 8. If a file is currently open, its name will be displayed on this screen. The last line on this and most screens is a message or status line.

Working with CSLIDE Files

The user can manage files in CSLIDE through the file menu shown below in Figure 22. The file menu includes the following options:

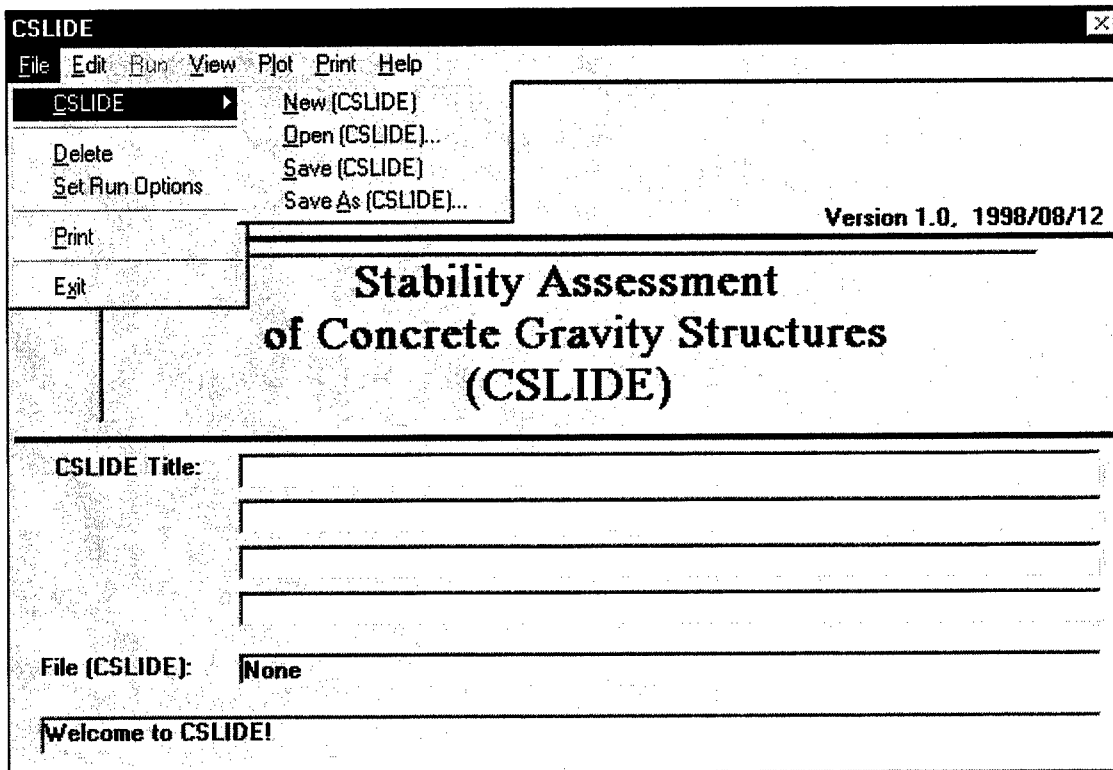

Figure 22. CSLIDE file menu

New

This option allows the user to interactively create a new data file without exiting the program.

Open

This item allows the user to view and edit an existing input file. When the Open option is selected, the program displays the following dialog (Figure 23).

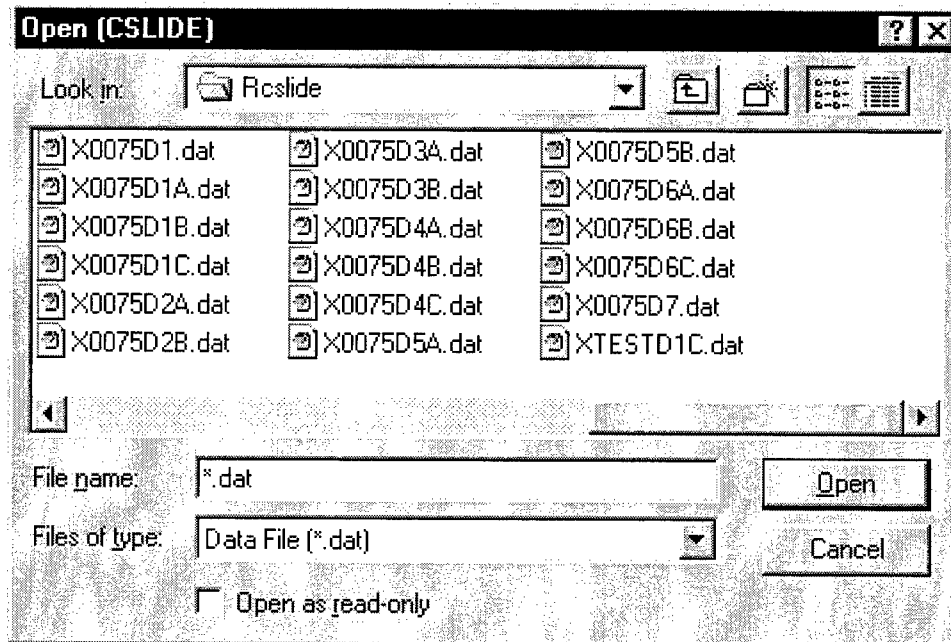

Figure 23. Open CSLIDE file dialog box

The dialog in Figure 23 displays files with the .dat file extension in the application's directory, which is usually \RCSLIDE. The file type displayed may be selected as data files (*.dat) or all files (*.*), where data files is the default.

CSLIDE's sample input files provided on the installation diskette have a X0075D# file format, where # represents the number and letter of the sample problem in Appendix A. Files possessing the RELID# format are sample reliability files used with RSCLIDE. By navigating using the drive and directory sections, the user can employ this dialog to locate and open the desired input file.

Save

Use to save the current input file. This option should only be used with existing input files. Newly created files should be stored for the first time with the **Save As** option.

Save As

After creating an input file or editing an existing one, the Save As option provides the user with the ability to specify the name and path where the information will be saved through the dialog box shown in Figure 24.

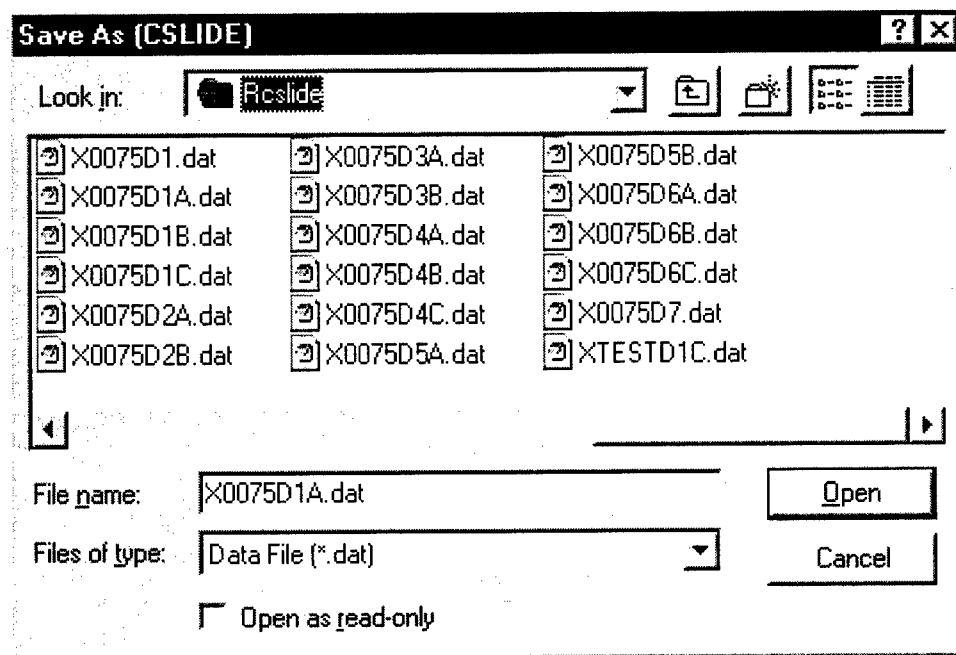

Figure 24. CSLIDE Save As dialog box

Delete

This item allows the user to delete any associated input or output through the Figure 25 dialog box.

Set Run options

Provides the user with the ability to change the application selection choice made when the program was first executed. Figure 17 shows the Set Run options dialog box, which was described earlier in this chapter.

Print

Used to print a file by means of a dialog box similar to that shown for the delete command in Figure 25.

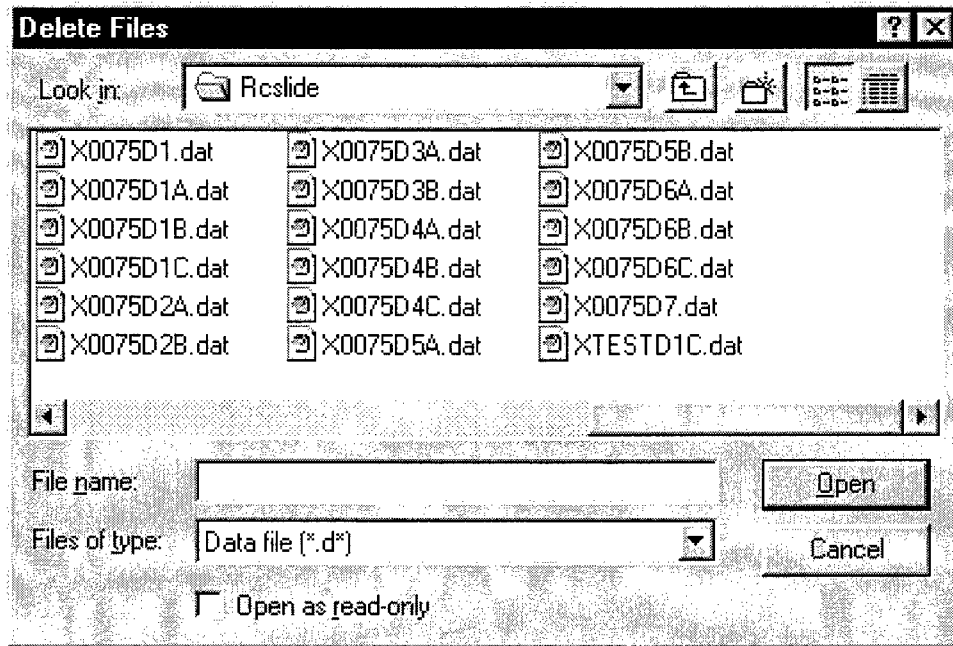

Figure 25. Delete dialog box

Exit

Used to terminate the current program session. If the current file has unsaved information, the following dialog box, Figure 26, will appear.

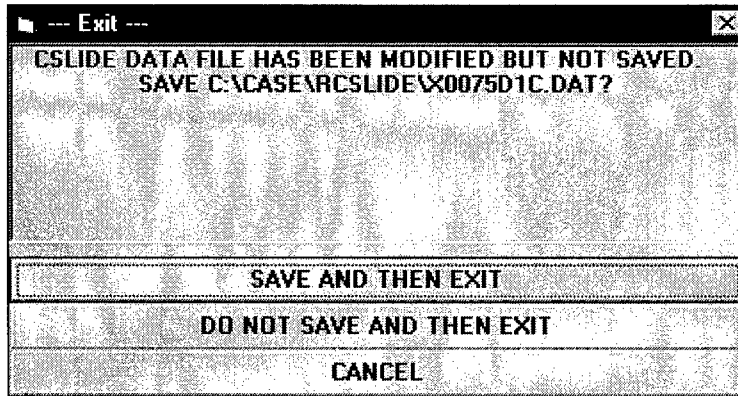

Figure 26. Exit dialog box when modified data file has not been saved

Specific descriptions of CSLIDE's other menus and options are detailed in Chapter 8, CSLIDE Input Guide.

8 CSLIDE Input Guide

The CSLIDE module can analyze stability problems with a variety of soil geometries, structure geometries, and loading conditions. A general soil/structure system that can be analyzed by CSLIDE is shown in Figure 27.

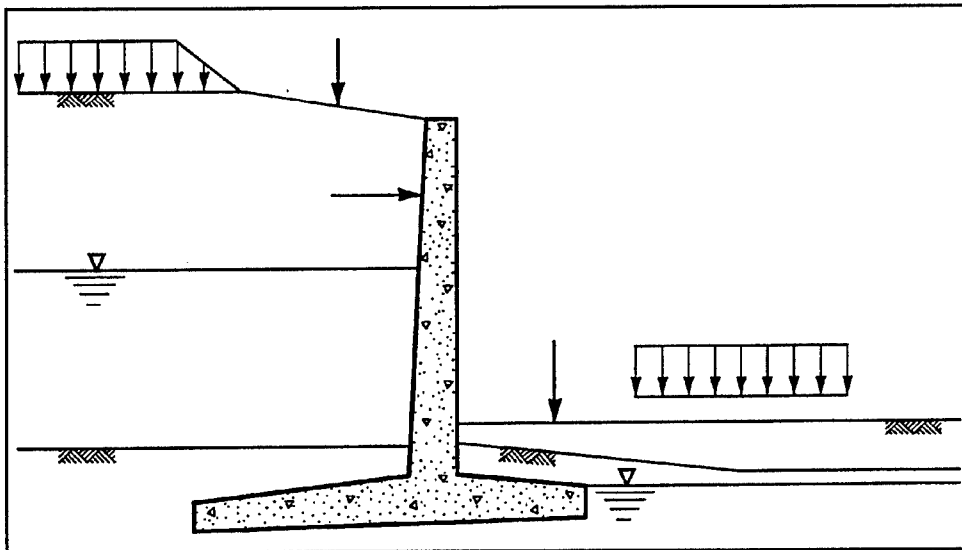

Figure 27. General soil/structure system

Program data can be entered from a data file created prior to program execution (see Appendix A for data file format) or interactively through the program's user interface. Program input is supplied on the following screens:

- a. Title
- b. Structural information
- c. Soil properties
 - (1) Method of analysis
 - (2) Left-side soil description
 - (3) Right-side soil description

- (4) Description of soil below the structure
- d.* Soil coordinates
 - (1) Left-side
 - (2) Right-side
- e.* Water description
- f.* Safety factor ratio
- g.* Loading conditions
 - (1) Vertical surcharge loads
 - (2) Horizontal loads
- h.* Anchors
- i.* Earthquake conditions
- j.* Wedge angle specifications

This chapter provides details about each section and how to enter the data.

Minimum Required Data

The following data are required to perform an analysis.

- a.* Heading
- b.* Structural description
- c.* Left-side soil description
- d.* Right-side soil description
- e.* Description of soil below structure
- f.* Method of analysis
- g.* Water description

Data entry screens may be selected in any order, since the program arranges the data into a file in the correct order.

Data Format and Sign Convention

CSLIDE reads in data that are in a free field format with data items separated by one or more blank spaces and does not accept files that are comma delimited files. It requires integers to be in nondecimal format, but real numbers may be in either decimal, nondecimal, or E format.

The program uses a right-hand coordinate system. Coordinates may be input using any quadrant or quadrants. Positive angles are taken counterclockwise from the horizontal, and negative angles are taken clockwise from the horizontal. The sign conventions for the various load types are shown in the Figure 28 and Units and Sign Conventions table (Table 1) that follow.

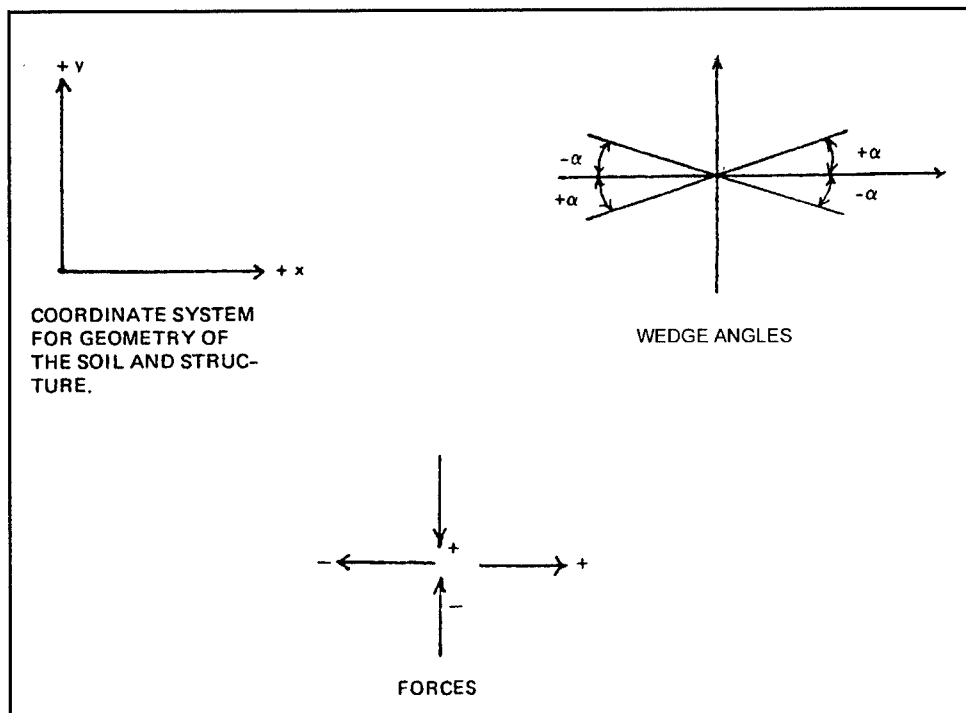

Figure 28. Sign convention for wedges

Units and Sign Conventions

All data must be entered in the following units:

- a. Length feet
- b. Force kips
- c. Angles degrees

All output is given in the same units as the input. Table 1 shows the units associated with various items of input.

Table 1 Units and Sign Conventions		
Item	Units	Sign Convention
Horizontal distances	ft	Negative or positive; values increase from left to right
Vertical distances	ft	Negative or positive; values increase from bottom to top
Unit weights	kcf	
Angle of internal friction	deg	
Failure angles	deg	Clockwise (negative), counterclockwise (positive); angles are rotated from the horizontal axis
Cohesion	kst	
Vertical Loads:		
Strip, ramp, triangular, and uniform surcharges	k/ft	Positive; downward
Point/line loads	kips	Positive; downward
Uplift force on structure because of water	kips	Positive; upward
Horizontal loads	kips	Positive to the right
Earthquake loads:		
Vertical coefficient		Positive; downward
Horizontal coefficient		Positive; to the right
Water pressures	kst	Positive; upward
Anchor Force:		
Force	kips/ft of wall	
Angle	deg	Clockwise (positive); angles are rotated from the vertical axis

Title

The Title section of the main CSLIDE screen (Figure 29) provides four fields to enter the problem's heading. Each line, up to a maximum of 4, may contain up to 70 alphanumeric characters. This information will be printed in the output file's heading. The default is a blank title.

Structural Information

The Structural Information window is located by first selecting the **Edit** option on the main menu bar and then selecting the **Structural Information** option on the pull-down menu as shown in Figure 30.

The following figure (Figure 31) shows the Structural Information window.

Unit weight of concrete is the equivalent weight of the structure to be analyzed in kcf.

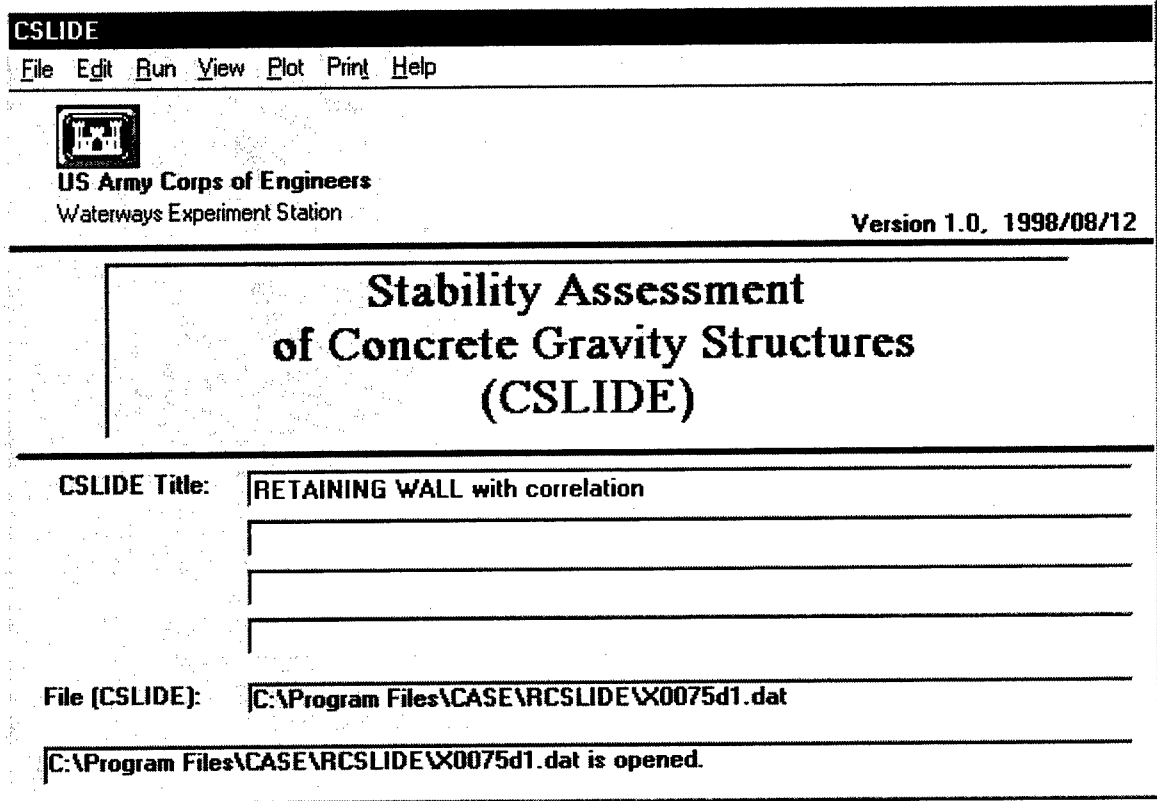

Figure 29. Title section of CSLIDE main window

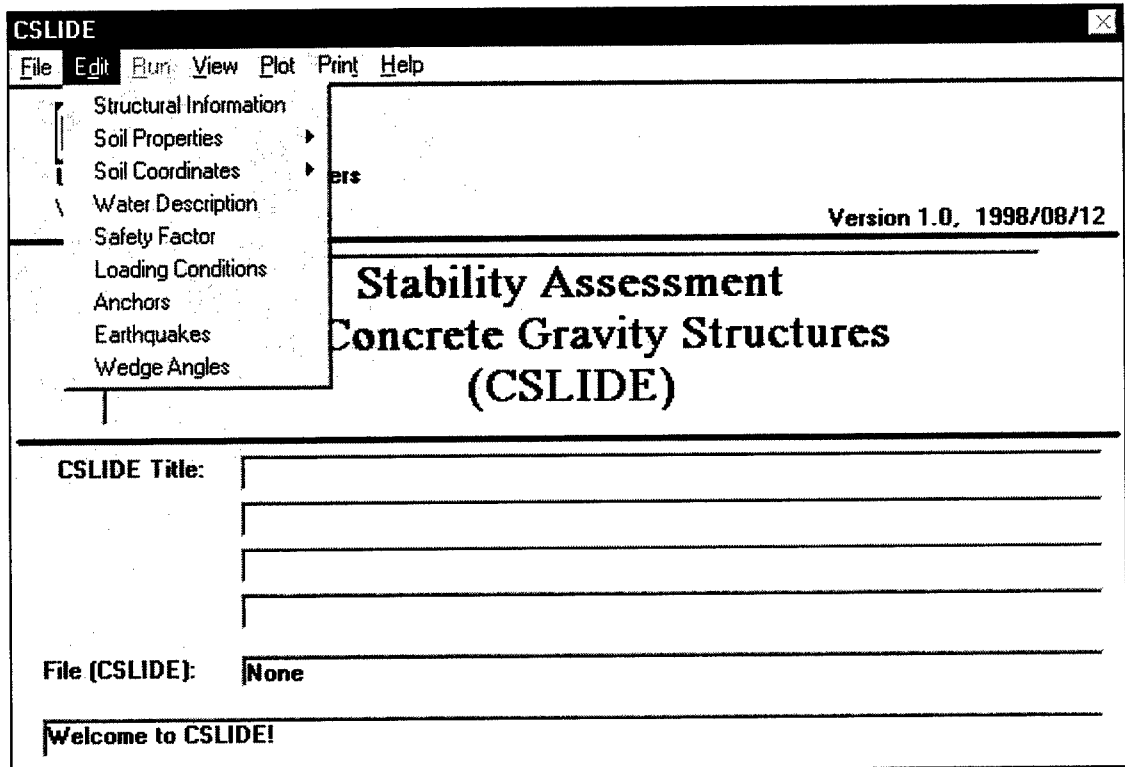

Figure 30. Edit options on the main screen

Structural Information

Delete Print Help

1. Unit weight of concrete (kcf):

2. Elevation of failure angle at left side (ft):

3. Fraction of base in compression (<=1):

Point count:

[(Clockwise order from lower left corner)] 5. X-coord.:

4. Point No. (max=20): 6. Y-coord.:

Node No.	X-coord.	Y-coord.
Node 1	0.0000	0.0000
Node 2	0.0000	2.0000
Node 3	6.0000	2.0000
Node 4	6.0000	14.0000
Node 5	8.0000	14.0000

C:\CASE\ARCSLIDE\X0075D1A.DAT is opened.

Figure 31. Structural description window

Elevation of failure angle left side specifies the elevation of the wedge-structure intersection on the active side of the structure in feet. The elevation must always be at or above the lower left corner of the structure (the default value) and below the top of the lowest soil layer on the active side. This value must be specified if the fraction of the concrete base in compression is given. The fraction base in compression must be between 0 and 1, and its default value is 1.

A structure may be described using up to 20 points, starting with the lower left corner and proceeding clockwise. The base of the structure must be represented as a single line; therefore, any irregularities in the structure's base must be approximated by a single plane. Point count field displays the number of points in the input file or that have been entered using the point number and x- and y-coordinate fields (i.e., items 4-6).

To delete structural coordinate points, select **Delete** on the Structural Information menu bar (Figure 32). The choice of **Last Point** will remove the last coordinate point in the structure (i.e., the maximum point entered in field 4), whereas **All Points** will eliminate all coordinate points that have been entered.

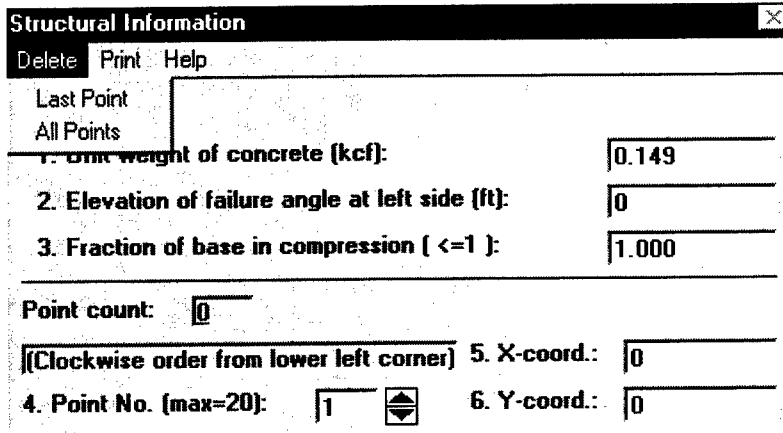

Figure 32. Delete structural points options

Soil Description

Entering a complete soil description requires data to be entered in the Soil Properties and Soil Coordinates sections of the Edit menu.

Soil properties

When Soil Properties is selected, the menu, Figure 33, used to select a method of analysis, left- and right-side soil description, and description of soil below the structure is presented.

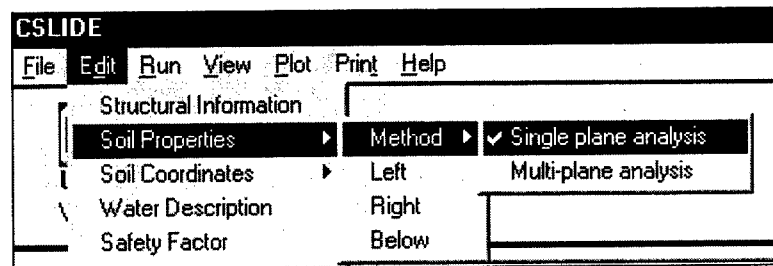

Figure 33. Soil Properties menu options

Method. To specify a failure plane method of analysis, select one of the methods listed in the **Method** option under the Soil Properties item of the Edit menu. The selected method will be displayed on the first line of the soil property description screen. Chapter 5 presented the specific details of each of these analysis methods. In single-plane failure analysis, failure angles are calculated to 0.001 ± 0.0005 deg; whereas, in multi-plane failure analysis, they are calculated to 0.1 ± 0.05 deg in order to decrease the number of calculations required.

Left-Right. Choosing either left or right will bring up the soil property description window, which is used to input the angle of internal friction, cohesion,

saturated unit weight, and the elevation of the top layer for each soil layer. This window is displayed in Figure 34, where the total layers field gives the number of soil layers in the input file for which a layer number and its property description information has been entered.

Soil Property Description

Print Help

Method: 1=Single plane Side: SOLT=Left-side soil description

Total layers: 0

1. Layer number (max=5): 1

2. Total points (max=5): 1

3. Angle of internal friction of the layer (deg): 28

4. Cohesion of the layer (ksf): 0.05

5. Saturated or moist unit weight (kcf): 0.12

6. Elevation of the top of the layer (ft): 14

Ok Cancel

Figure 34. Soil Property Description

The program permits entry of a maximum of five soil layers on the left and right side of the structural wedge. The program limits each layer's description to five points that are entered using the soil coordinates window described later in this chapter.

The right-side soil is always considered to be the passive side; whereas, the left-side soil is the active side.

All left-side soil elevations at the structure must be above the lower left corner of the structure. But if only one soil layer is entered, it can be at the elevation of the lower left corner of the structure. All left-side soil elevations at the structure must be above the elevation of the wedge-structure intersection.

All right-side soil elevations at the structure must be above the lower right corner of the structure. But if only one soil layer is entered, it can be at the elevation of the lower right corner of the structure.

Below. When more than one type of soil comes into contact with the base, the angle of internal friction and the cohesion values should be represented as an average or equivalent value. Figure 35 displays the input screen for properties of soil below the structure.

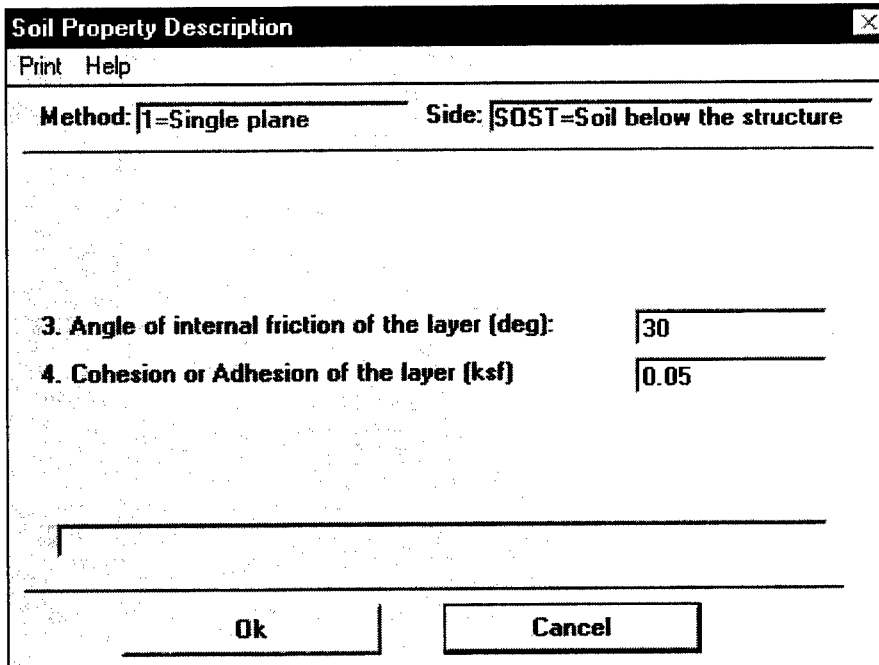

Figure 35. Soil below the structure

If the base of the structure is part of the failure surface, an angle of base friction and an adhesion value would be used. If the failure surface passes below the base of the structure, the material properties of the soil and angle of internal friction and a cohesion value would be used.

Soil coordinates

When either left- or right-side is selected for soil coordinate input (Figure 36), the Soil Coordinate window will appear, which is used to input the points defining each soil layer. The x- and y-coordinate for each point in each layer is displayed on the right side of this window (Figure 37).

The soil layers are defined from top to bottom. Enter the points describing each soil layer from left to right, excluding the point at the structure. Soil boundaries are automatically extended 1,000 ft to the left of the first coordinate entered.

Water Description

The water description input window is used to account for any uplift effects because of the presence of water. Figure 38 depicts a water description window on which the items displayed will change depending upon the method of computing uplift chosen.

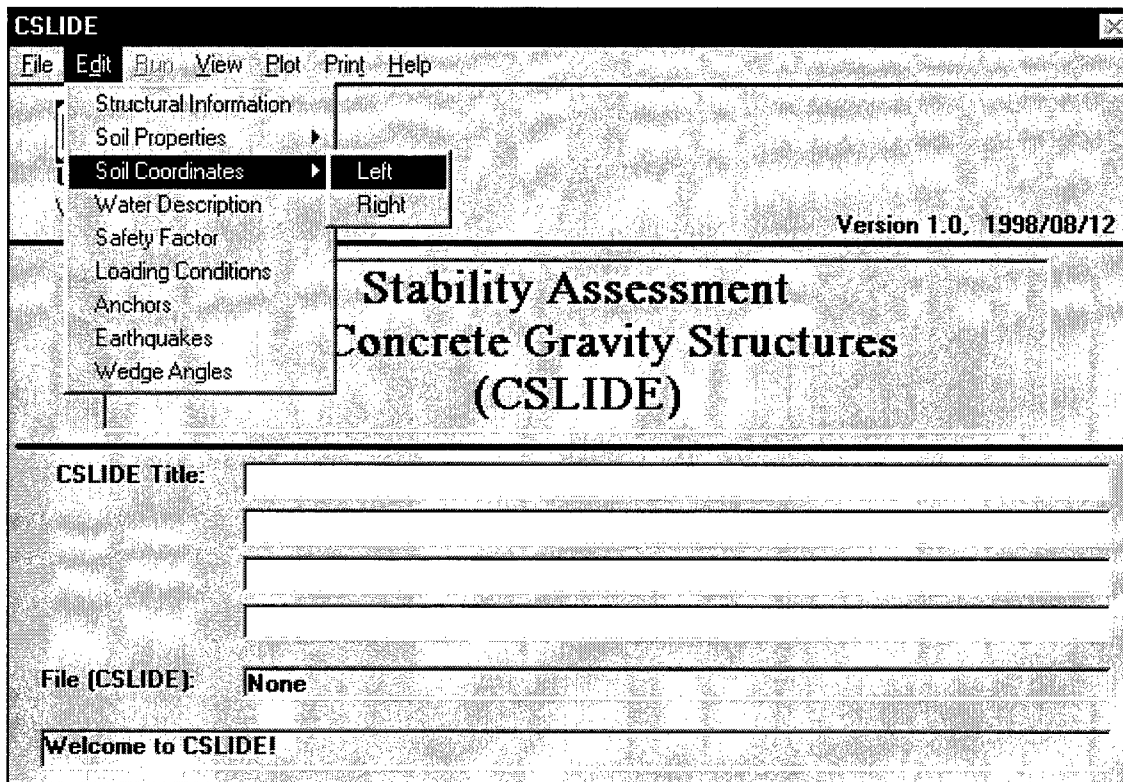

Figure 36. Soil Coordinates selection

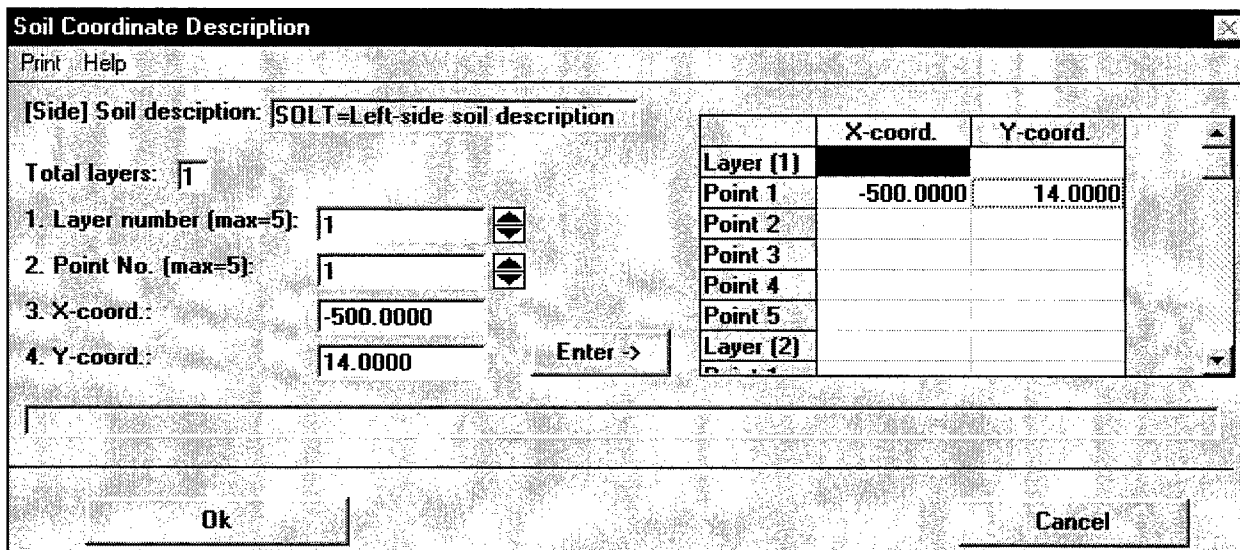

Figure 37. Soil Coordinate window

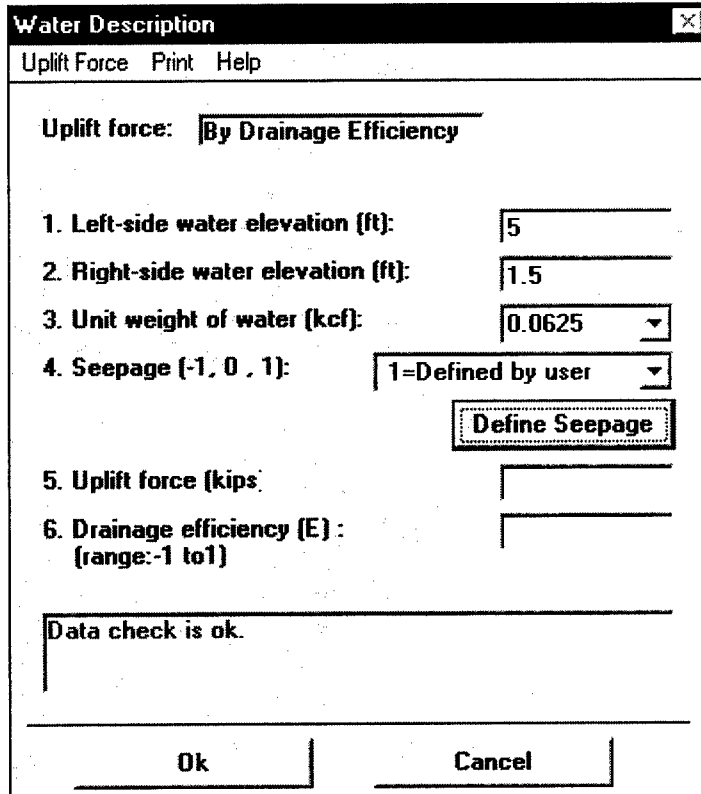

Figure 38. Water Description window

The unit weight of water and the left- and right-side water elevations are required (i.e., item numbers 1-3). The water elevations may be higher on either side of the structure.

CSLIDE provides the following methods of computing uplift:

- a. Pressures may be input at the top and bottom of each wedge and at five points along the base of the structure (Seepage option = 1).
- b. Hydrostatic pressure calculations may be specified, or if there is no difference in head, hydrostatic pressures are automatically calculated (Seepage option = 0).
- c. Line of creep method along the shortest seepage path may be used (Seepage option = -1).
- d. An uplift force may be specified for the structural wedge. This may be used in combination with any method for computing seepage pressures (Input Uplift Force).
- e. A drainage efficiency value may be given to compute an uplift force normal to the base of the structural wedge (Drainage Efficiency). The equation used to calculate the uplift force (U) is defined in Wolff and Wang (1992) as:

$$U = \frac{1}{2} [2H_R + (1-E)(H_D - H_R)] B\gamma_w \quad (15)$$

where

H_R = height of water on resisting side above base of structure

E = drainage efficiency

H_D = height of water on driving side above base of structure

B = width of base

γ_w = unit weight of water

Any one of these five methods may be selected on the Water Description screen by choosing **Uplift Force** and then selecting **Seepage Option**, **Input Uplift Force**, or **Drainage Efficiency** as shown in Figure 39. The default method is to use one of the seepage options.

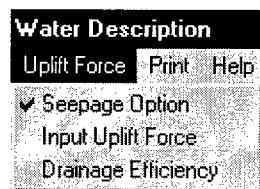

Figure 39. Uplift Force menu selections

Seepage

CSLIDE provides three methods for defining seepage:

- a. -1: Line-of-creep method calculated along the shortage seepage path.
- b. 0: Hydrostatic pressures to be computed.
- c. 1: Pressures defined by user.

Unless specified otherwise, the program defaults to the line-of-creep method for calculating seepage pressures. The one exception is if water pressures are the same on both sides of the structure; there is no seepage, and hydrostatic pressures are automatically calculated.

If the user chooses to define seepage pressures, a value of **1 = Defined by user** must be selected in field 4 on the Water Description screen as displayed in Figure 40. Then select the **Define Seepage** button to obtain a window similar to Figure 41 for entering seepage pressures.

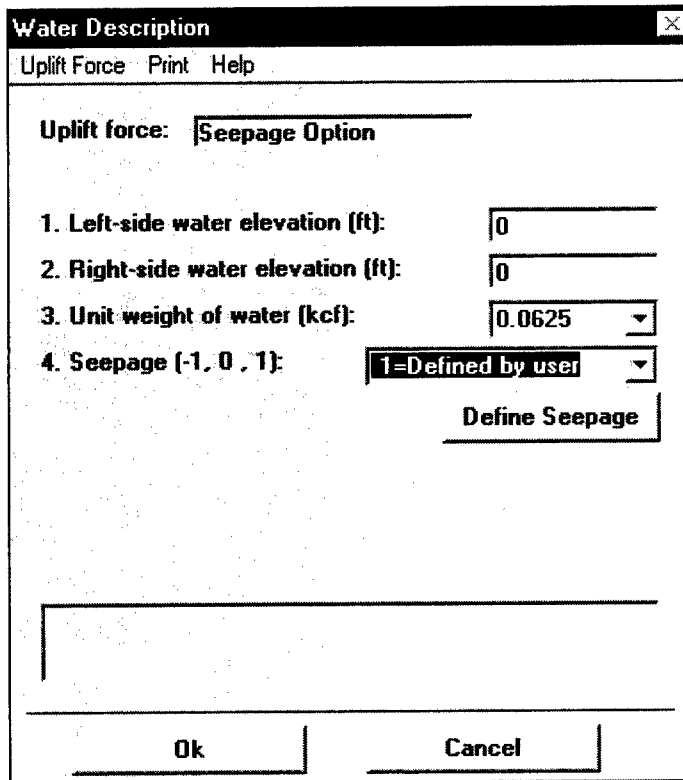

Figure 40. Seepage pressure defined by user selection

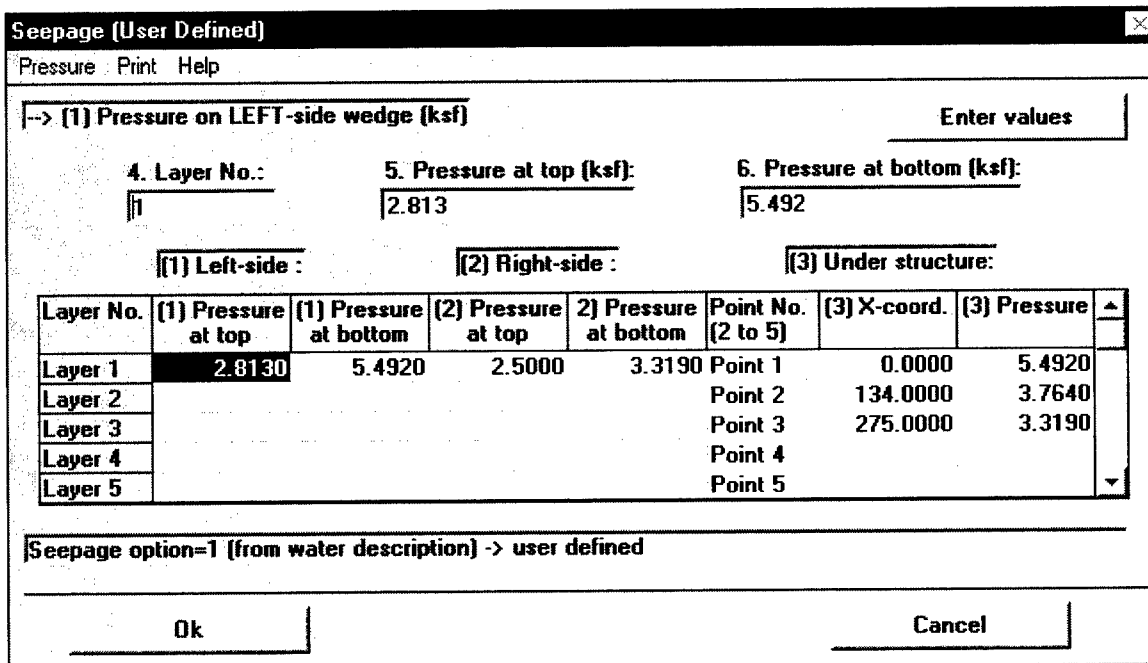

Figure 41. User-defined water pressures on wedges

Using the seepage definition window, the user can specify the pressures at the top and bottom of the left-side and right-side wedges and can enter the x-coordinate and pressure values for up to five points under the structural wedge. Users may specify left-side wedge and right-side wedge pressures for up to 10 layers.

The pressures entered for a wedge will be applied only to the submerged length of the wedge, which is calculated from the water elevations. Therefore, it is important to input the correct water elevations when using this option. To input pressure data values, choose the location of the pressure on the Seepage (User Defined) screen by selecting **Pressure** from the menu bar and then selecting one of the locations given in Figure 42. Depending upon the pressure location, one of Figures 43 to 45 will be displayed. Enter the values specified in the fields provided, and click the **Enter Values** button for each layer or point entered.

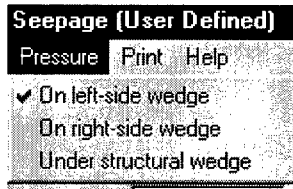

Figure 42. Seepage Pressure location menu selections

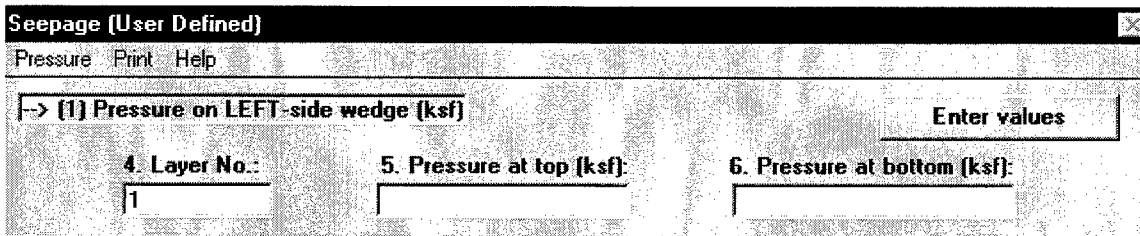

Figure 43. Seepage pressure on left-side wedge

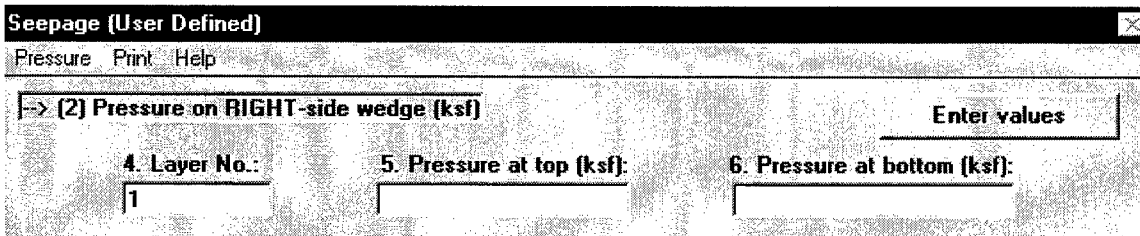

Figure 44. Seepage pressure on right-side wedge

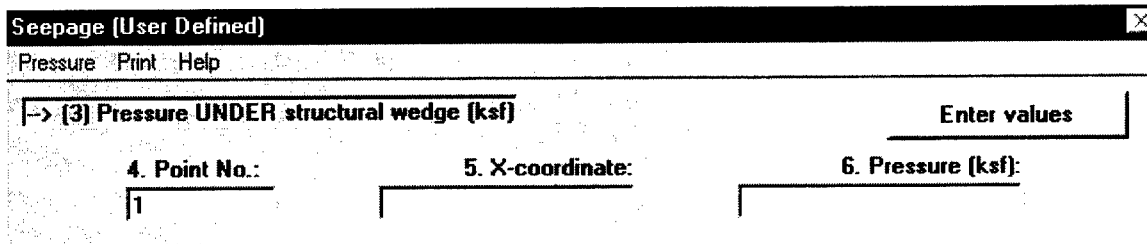

Figure 45. Seepage pressure under structural wedge

Pressures for all the left-side wedges and all the right-side wedges are entered from the highest elevation (top) to the lowest elevation of each wedge (bottom) and are distributed linearly between the points entered.

For pressures entered at points under the structural wedge, the pressure is distributed linearly between the points entered. The horizontal distance is always used to locate a pressure. The program automatically calculates the sloped distance between pressure values when the base of the structure is inclined to the horizontal.

Input uplift force

The value for an uplift force normal to the base may be directly specified in field 5 of the Water Description screen (Figure 46). When this method is used to define uplift, a method for calculating seepage pressures must also be selected in field 4.

Drainage efficiency

A drainage efficiency value may be specified in field 6 of the Water Description screen (Figure 47). This value is then used to compute an uplift force normal to the base of the structural wedge.

Safety Factor

An upper and lower limit may be specified for the FS to aid in the interpolation for new factors of safety (Figure 48).

A ratio of the passive FS to the active FS may also be specified (default value = 1.0).

Loading Conditions

The loading conditions window provides the ability to specify external vertical and horizontal loads applied. To specify a load type, choose Loads on the menu

Water Description [X]

Uplift Force Print Help

Uplift force: **By Input**

1. Left-side water elevation (ft):

2. Right-side water elevation (ft):

3. Unit weight of water (kcf):

4. Seepage (-1, 0, 1):

5. Uplift force (kips):

Figure 46. Uplift force defined by input

Water Description [X]

Uplift Force Print Help

Uplift force: **By Drainage Efficiency**

1. Left-side water elevation (ft):

2. Right-side water elevation (ft):

3. Unit weight of water (kcf):

4. Seepage (-1, 0, 1):

5. Uplift force (kips):

6. Drainage efficiency (E) :
[range:-1 to1]

Figure 47. Uplift Force determined by drainage efficiency

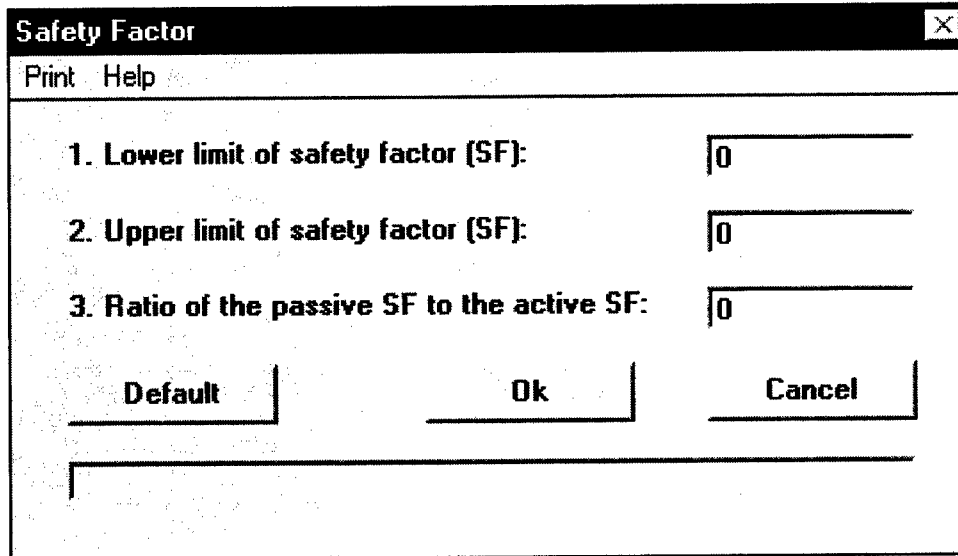

Figure 48. Factor of Safety input window

bar of Loading Conditions window and then select appropriate type as shown in Figure 49. As noted in Chapter 6, these values will be summed with the horizontal and vertical loads because of the presence of water next to the wedge and any induced horizontal and vertical loads because of horizontal and vertical earthquake acceleration.

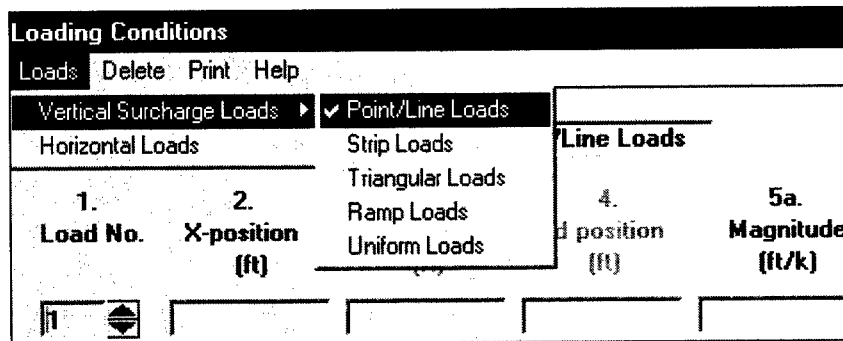

Figure 49. Loads submenu on Loading Conditions window

CSLIDE allows data entry of five types of vertical surcharge loads. The program permits entry of a maximum of five loads for each type except for uniform loads for which two are allowed. The vertical surcharge loads include point/line loads, strip loads, triangular loads, ramp loads, and uniform loads.

If the user selects to enter a point/line load and the load lies directly on the vertical boundary line that separates adjacent wedges, the load is included in the calculations of the wedge to the right. Figure 50 depicts the data entry screen for point/line loads. An x-coordinate and magnitude is required for each load entered.

Loading Conditions

Loads Delete Print Help

[[Load] Loading condition: Vertical - Point/Line Loads

1. Load No.	2. X-position (ft)	3. Peak-position (ft)	4. End position (ft)	5a. Magnitude (ft/k)
1				

Enter

Figure 50. Point/Line Loads data entry screen

Figures 51 to 53 are the data entry screens for strip, triangular, and ramp loads. For strip loads, the x-coordinate at the left end of the strip, the strip's width, and load's magnitude must be given. In the case of triangular loads, the x-coordinate at the left end of the load, the width from the left end to the maximum load, the width from the maximum load to the right end, and the magnitude of the maximum load are necessary. An x-coordinate for the starting point of the ramp, its width, and maximum load are required for each ramp load.

Loading Conditions

Loads Delete Print Help

[[Load] Loading condition: Vertical - Strip Loads

1. Load No.	2. X-position (ft)	3. Width (ft)	4. End position (ft)	5a. Magnitude (ft/k)
1	0	0	0	0

Enter

Figure 51. Strip Loads data entry screen

Loading Conditions

Loads Delete Print Help

[[Load] Loading condition: Vertical - Triangular Loads

1. Load No.	2. Left-end-X (ft)	3. Left-width (ft)	4. Right-width (ft)	5a. Magnitude (ft/k)
1	0	0	0	0

Enter

Figure 52. Triangular Loads data entry screen

The screenshot shows a window titled "Loading Conditions" with a menu bar containing "Loads", "Delete", "Print", and "Help". The main area is titled "[Load] Loading condition: Vertical - Ramp Loads". It contains a table with five columns: "1. Load No.", "2. Start-position (ft)", "3. Width (ft)", "4. End position (ft)", and "5a. Magnitude (ft/k)". Each column has a text input field with the value "0". The "Load No." field has a dropdown arrow and a small icon. An "Enter" button is located at the bottom right of the input area.

1. Load No.	2. Start-position (ft)	3. Width (ft)	4. End position (ft)	5a. Magnitude (ft/k)
0	0	0	0	0

Enter

Figure 53. Ramp Loads data entry screen

The uniform vertical load, which may be entered either on the left side or right side of the structure, extends over all of the soil surface and stops when the soil meets the concrete structure.

As shown in the uniform load data entry screen, Figure 54, the location, either left (L) or right (R) side of the structure, and magnitude of the load must be input. One load of this type is allowed on the active side and one on the passive side.

The screenshot shows a window titled "Loading Conditions" with a menu bar containing "Loads", "Delete", "Print", and "Help". The main area is titled "[Load] Loading condition: Vertical - Uniform Loads". It contains a table with five columns: "1. Side(L/R)", "2. Start-position (ft)", "3. Peak-position (ft)", "4. End position (ft)", and "5a. Magnitude (ft/k)". Each column has a text input field with the value "0". The "Side(L/R)" field has a dropdown arrow and a small icon. An "Enter" button is located at the bottom right of the input area.

1. Side(L/R)	2. Start-position (ft)	3. Peak-position (ft)	4. End position (ft)	5a. Magnitude (ft/k)
L	0	0	0	0

Enter

Figure 54. Uniform Loads data entry screen

Required data for each horizontal load includes the number of the wedge on which the load is applied and its magnitude (see Figure 55). Any number of horizontal loads may be placed on a wedge.

Any load may be deleted by selecting **Delete** on the Loading conditions menu bar. If the currently selected load type is a uniform load, the submenu shown in Figure 56 will be displayed. For all other load types, the Figure 57 submenu will appear. The meaning of the submenu commands is as follows:

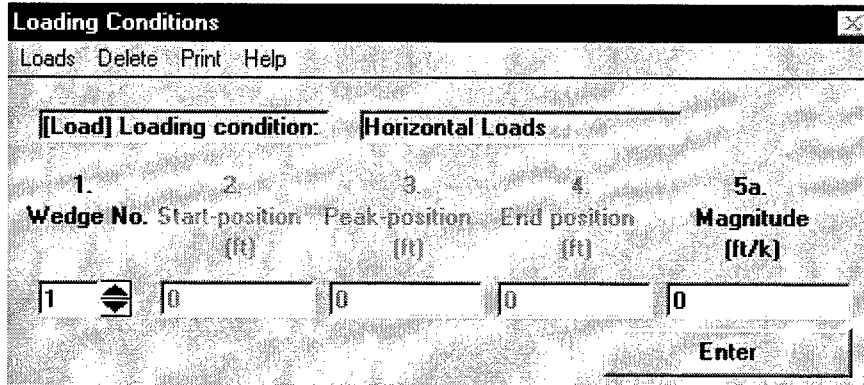

Figure 55. Horizontal Loads data entry screen

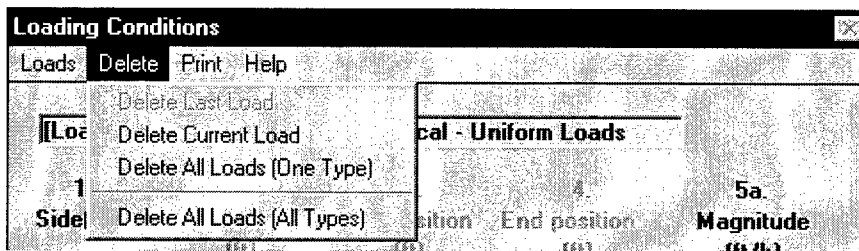

Figure 56. Delete Loads menu for uniform loads

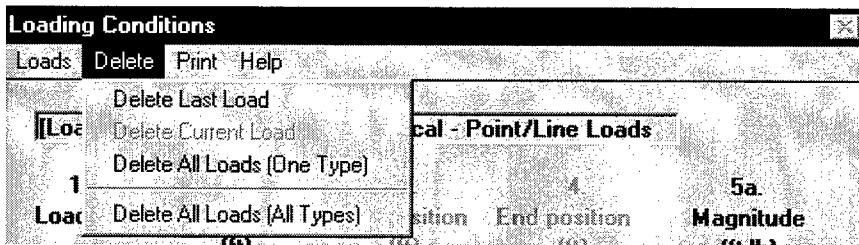

Figure 57. Delete Loads menu for other load types

- a. *Delete Last Load.* Deletes the last load defined in the current type. For example if three point/line loads have been input, the load 3 will be deleted. This command will not work with uniform loads.
- b. *Delete Current Load.* Deletes the current uniform load. This command only works with uniform loads.
- c. *Delete All Loads (One Type).* Deletes all loads of the currently selected type.
- d. *Delete All Loads (All Types).* Deletes every load that has been input.

Anchors

CSLIDE allows the user to specify data for up to three anchors within the same per foot width of wall (Figure 58). The anchor force and respective components are added to the structural wedge calculations. Users can represent other anchors by using the options under the vertical load section.

When entering values for the anchor, account for spacing when entering force values, and be aware that positive angles are in the clockwise direction from the vertical axis.

	Force (kips/ft) :	Angle (degrees from vertical) :
Anchor 1 :	60	0
Anchor 2 :	0	0
Anchor 3 :	0	0

Figure 58. Anchors window

Earthquake Conditions

The following window (Figure 59) allows the user to account for earthquake accelerations.

Vertical Acceleration Coefficient	0
Horizontal Acceleration Coefficient	0.2

Figure 59. Earthquake conditions

As discussed in Chapter 5, to account for earthquake accelerations, the vertical and horizontal seismic coefficients are multiplied by the total weight of a wedge to produce vertical and horizontal loads. These loads are applied to the wedge as additional static loads. ER 1110-2-1806 can be used to obtain the horizontal seismic acceleration coefficient, and the vertical can be taken as two-thirds of the horizontal.

Wedge-Angle Specifications

A window similar to the one shown in Figure 60 provides the user with the capability of specifying a failure angle for a given wedge. This information cannot be entered until the number of soil layers has been selected. The window displayed will vary depending upon the problem's number of soil layers (maximum of five on each side plus one for the structural wedge).

Failure Angles on the Left (deg)	
Wedge #1	
Wedge #2	0.00
Wedge #3	5.00

Failure Angles on the Bottom (deg)	
Wedge #4	

Failure Angles on the Right (deg)	
Wedge #5	

Figure 60. Example of a Wedge Angle Specifications window

For any soil wedge, values of the input angle may range from +85 to -85 deg, inclusive. Thus, layers that slope down and away from the base of the structure may be handled by the program. The line defined by the rotation of the angle should not extend into the interior of the structure. The input wedge angle must also allow the plane formed by the base of the wedge to intersect the soil layer in which the wedge is contained. When the single-plane analysis (Method 1, Figure 15, Chapter 5) is used for a multiple-layer problem, an angle set for any soil wedge (left or right) will cause all the angles of that side to be set to the input angle. Whereas, for multi-plane analysis, the wedge angles may vary on a particular side.

When an angle is input for the structural wedge, the geometry of the structural wedge is altered. The input angle will extend a plane at or below the base of the structure. The bottom corner point of the structural wedge opposite the input angle is moved down to a new elevation at the same x-coordinate. This point is the intersection of the line defined by the input angle with the x-coordinate

boundary of the structure. The point of rotation for the input angle is always the corner of the structure with the lowest elevation. For a structure with a level base, the input angle is rotated about the left corner of the structure. The soil beneath the structure is assumed to be an added vertical load, and the plane defined by the input angle is the new sliding plane. Thus, it is possible to examine a plane below the base of the structure for deep-seated sliding. The weight of the soil below the structure is calculated using the unit weight of the lowest soil layer that is opposite the side of the structure on which the input angle is applied.

9 RCSLIDE Input Guide

Background

The program RCSLIDE provides stability analysis and reliability assessment of concrete retaining walls and gravity structures. RCSLIDE contains the following main analysis functions.

- a.* Stability analysis for concrete walls and gravity structures using CSLIDE.
- b.* Reliability assessment using advanced second moment (ASM) method.
- c.* Reliability assessment using Monte Carlo simulation (MCS) with importance sampling (IS) and direct simulation.

In addition, RCSLIDE allows the preparation of input data for running each of these three main analysis functions, viewing the analysis results, and plotting the simulation results and structural geometry.

RCSLIDE requires the same sliding stability analysis data described in the “CSLIDE Input Guide,” Chapter 8. Knowing how to enter data for CSLIDE provides the basics needed to successfully enter data for RCSLIDE. Refer to Chapters 7 and 8 entitled “Getting Started with RCSLIDE/CSLIDE” and “CSLIDE Input Guide,” respectively, and “Appendix A” for details on entering this data.

Reliability assessment of structures requires the use of probability distributions for modeling basic random variables. Computer programs were developed (Ayyub and Chao 1994) for the following distributions:

- a.* Beta, BET
- b.* Exponential, EXP
- c.* Gamma, GAM
- d.* Lognormal, LOG
- e.* Normal, NOR

- f.* Rayleigh, RAY
- g.* Type I – Largest, T1L
- h.* Type I – Smallest, T1S
- i.* Type II – Largest, T2L
- j.* Type III – Largest, T3L
- k.* Type III – Smallest, T3S
- l.* Uniform, UNI

Each implementation of a probability distribution contains five functions for computing:

- a.* Probability density function (PDF)
- b.* Cumulative distribution function (CDF)
- c.* Inverse of cumulative distribution function (INV)
- d.* Moments (mean and standard deviation) from parameters (MOM)
- e.* Parameters from moments (PAR)

Working with RCSLIDE Files

Although the RCSLIDE interface permits the user to create a CSLIDE file interactively, opening a prepared CSLIDE file provides the most convenient way to enter sliding stability data for RCSLIDE. To open a CSLIDE file from RCSLIDE, select **CSLIDE** from the file menu, then **Open (CSLIDE)** (Figure 61).

In addition to the menu options used in the CSLIDE module, RCSLIDE provides four options that allow users to store and retrieve reliability data, which are similar to their respective CSLIDE versions (Figure 62).

Reliability data is also stored in sample input files with a .dat file extension. RCSLIDE creates these files from data contained in the CSLIDE input file and reliability data entered interactively by the user. To perform a structural reliability assessment using RCSLIDE, the user must select to save the reliability information to a file or choose to open an existing file containing the required data.

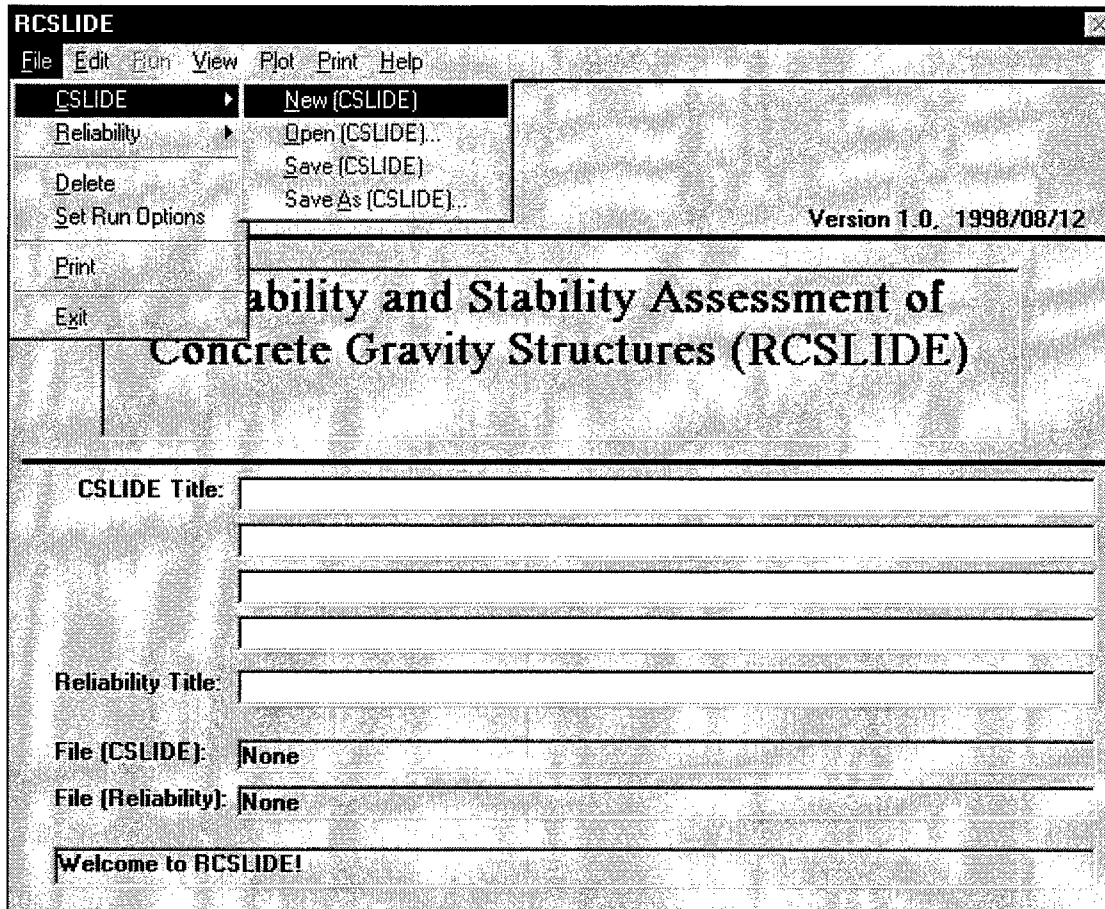

Figure 61. RCSLIDE File Menu

Input Data

Figure 63 shows the structural description window of RCSLIDE with the reliability fields included. This is a typical arrangement for windows that contain reliability information.

When performing a reliability assessment, RCSLIDE expects the following data as input in order to create the reliability file used for the analysis:

- a. Mean
- b. Standard deviation, Stddv
- c. Coefficient of variation, COV
- d. Code
- e. Distribution

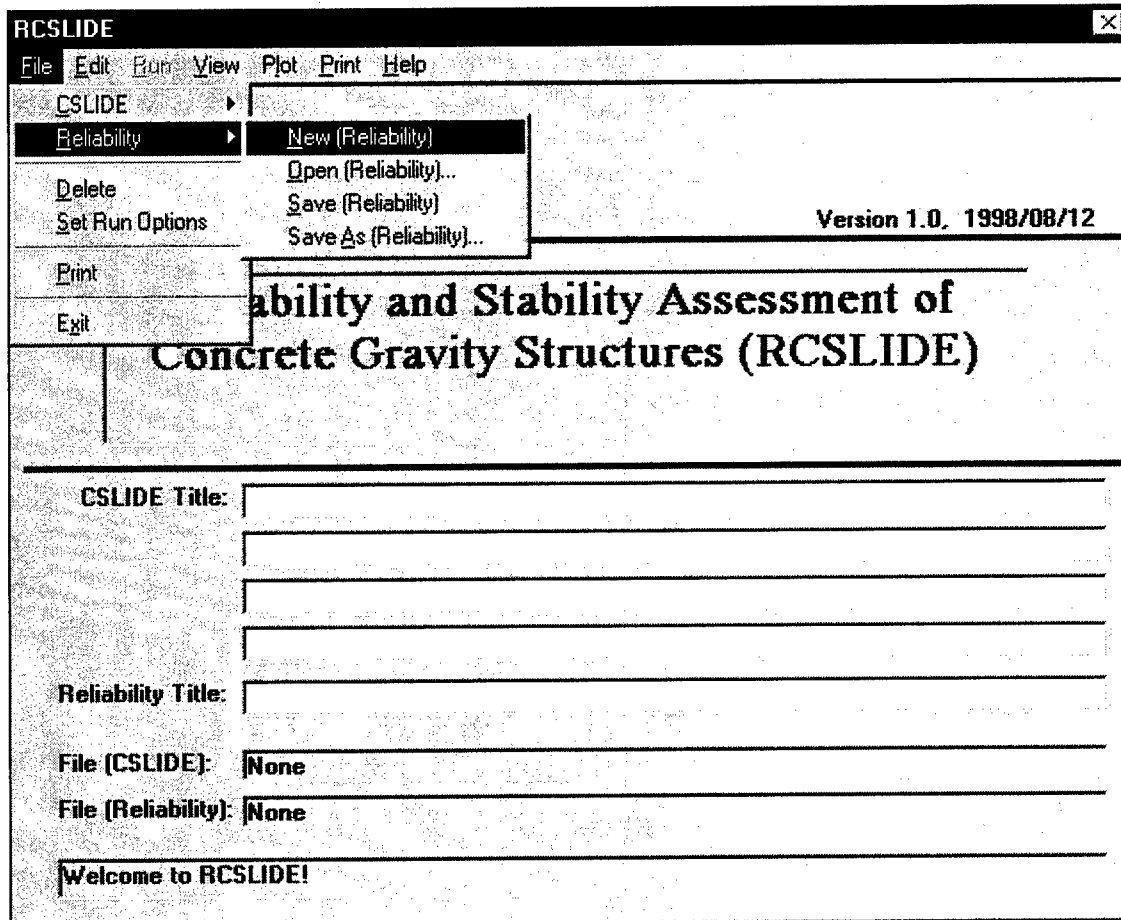

Figure 62. RC SLIDE Reliability File menu

Mean

The mean value represents the arithmetic average of a set of values, and for a set of measured values for the random variable X , it can be expressed as:

$$\mu_x = \frac{\sum X_i}{N} \quad (16)$$

where N is the number of values for X . RC SLIDE extracts this mean value from the CSLIDE input file.

Standard deviation

The standard deviation is used to express the scatter of a random variable in the same units as the random variable itself. It is defined as the square root of the variance, which is presented in the following equation:

RCSLIDE Structural Information

Delete Print Help

	a. Mean	b. Stddv/COV	c. Code	d. Distribution
1. Unit weight of concrete (kcf):	0.15	0.15	C	NOR
2. Elevation of failure angle at left side (ft):	0	0	C	NOR
3. Fraction of base in compression (<=1):	1	0	C	NOR

Default

Point count:

[(Clockwise order from lower left corner)]

4. Point No. (max=20):

5. X-coord.:

6. Y-coord.:

C:\CASE\RCSLIDE\RELID1C.DAT is opened.

Node No.	X-coord.	Y-coord.
Node 1	0.0000	0.0000
Node 2	0.0000	2.0000
Node 3	6.0000	2.0000
Node 4	6.0000	14.0000
Node 5	8.0000	14.0000
Node 6	8.0000	2.0000
Node 7	12.0000	2.0000
Node 8	12.0000	0.0000

Ok Cancel

Figure 63. Structural description window with reliability fields

$$\sigma_x = \sqrt{\sigma_x^2} \quad (17)$$

Coefficient of variation

To provide a dimensionless measure of uncertainty inherent in a random variable, the standard deviation is divided by the expected value (mean value extracted from CSLIDE input file) to obtain the coefficient of variation.

$$V_x = \frac{\sigma_x}{E[X]} \times 100 \% \quad (18)$$

Code

The code field allows the user to specify whether the value in Stddv/COV field represents the standard deviation (S) or the coefficient of variation (C).

Distribution

This field allows the user to specify any one of the probability distributions listed earlier in this chapter for use during a reliability assessment.

Each of these five fields is included on the screens used to define the following:

- a. Structural Description (Figure 63)
- b. Left-Side (Figure 64) and Right-Side Soil Properties. It is recommended that only three soil layers per side be used when performing a reliability assessment.
- c. Soil Properties Below Structure
- d. Water Description (main window only (Figure 65))
- e. Loading Conditions (Figure 66)

	a. Mean	b. Stddy/COV	c. Code	d. Distribution
3. Angle of internal friction of the layer (deg):	28	0.3	C	NOR
4. Cohesion of the layer (ksf)	0.05	0.2	C	NOR
5. Saturated or moist unit weight (kcf):	0.12	0.1	C	NOR

Figure 64. RCSLIDE Soil Property Description window

Information entered for earthquake conditions and wedge-angle specifications will be ignored when a reliability assessment is performed using the ASM or simulation methods.

RC SLIDE: Water Description [X]

Uplift Force Print Help

Uplift force: **By Drainage Efficiency**

	a. Mean	b. Stdev/COV	c. Code	d. Distribution
1. Left-side water elevation (ft):	5	1	S	NOR
2. Right-side water elevation (ft):	1	1	S	NOR
3. Unit weight of water (kcf):	0.0625			
4. Seepage (-1, 0, 1):	1=Defined by user		Define Seepage	
5. Uplift force (kips):				
6. Drainage efficiency (E) : [range:-1 to1]		0	C	NOR

C:\CASE\RC SLIDE\X0075D1C.DAT is opened.

Ok Cancel

Figure 65. RC SLIDE Water Description window

Since the variables on the safety factor, user-defined seepage, and anchor screens are not treated as random, these screens remain the same for a CSLIDE analysis and a reliability assessment.

Loading Conditions [X]

Loads Delete Print Help

[[Load] Loading condition: Vertical - Point/Line Loads

1. Load No. 2. X-position (ft) 3. Peak-position (ft) 4. End position (ft)

5a. Magnitude (ft/k) 5b. Stddv/COV 5c. Code 5d. Distribution

2 [22] [] [] [] [2] [] [C] [NDR=Normal] Enter

1. Load No.	2. X-position (ft)	3.	4.	5a. Magnitude (k/ft)	5b. Stddv/COV	5c. Code
Load 1	22			2		C
Load 2						
Load 3						
Load 4						

Ok

Figure 66. RCSLIDE Loading Conditions window

10 Program Output

Both a CSLIDE analysis and the RCSLIDE reliability assessment will calculate a factor of safety for the sliding stability. The factor of safety (FS) can be expressed as

$$FS = \frac{R}{L} \quad (19)$$

where

R = resistance in the form of a restoring strength

L = load effect in the form of the sliding force

In addition, the reliability assessment computes a reliability index and a probability of unsatisfactory performance.

Before attempting to run an analysis, both RCSLIDE and CSLIDE require users either to have saved a newly created data file(s) or opened a data files(s). Once the data file(s) is opened or saved, the **Run** command will be visible on the main menu bar.

Select **Run**, then **Run CSLIDE** or **Run RCSLIDE** to display the default execution screens (Figure 67 for CSLIDE and Figure 68 for RCSLIDE). The potential choices on the Run CSLIDE and Run RCSLIDE main menu bar are as follows:

- a. *File*. Used to exit the program or save the input/output files that will be discussed in detail later in this chapter.
- b. *Analysis*. Used to select the method of analysis. The choice is not available on the Run CSLIDE screen.
- c. *Print-Print Form*. Prints a screen copy. For example, it will print Figure 67.
- d. *Options*.

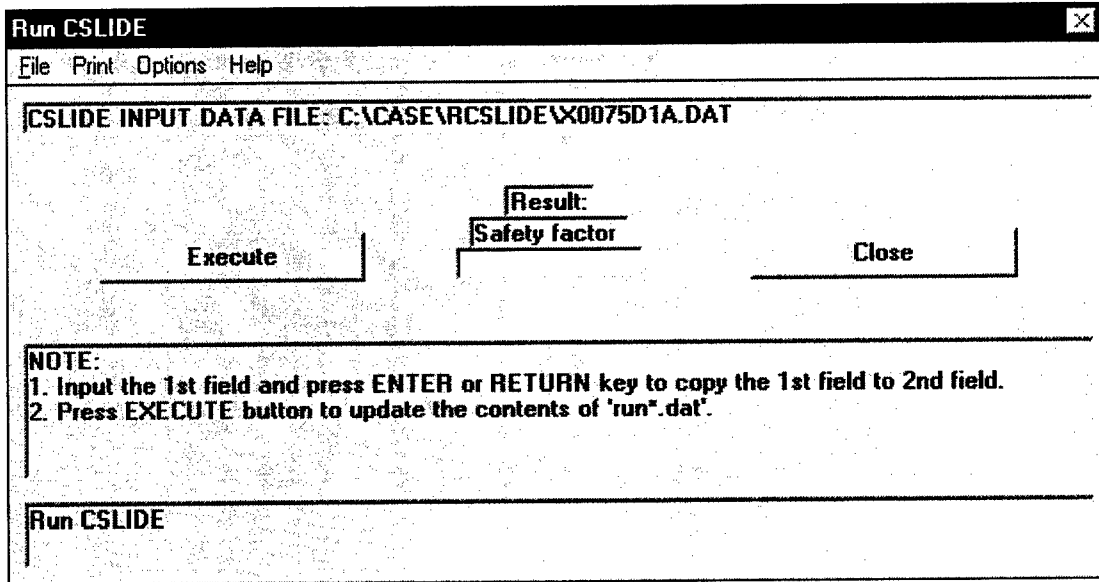

Figure 67. CSLIDE Run screen

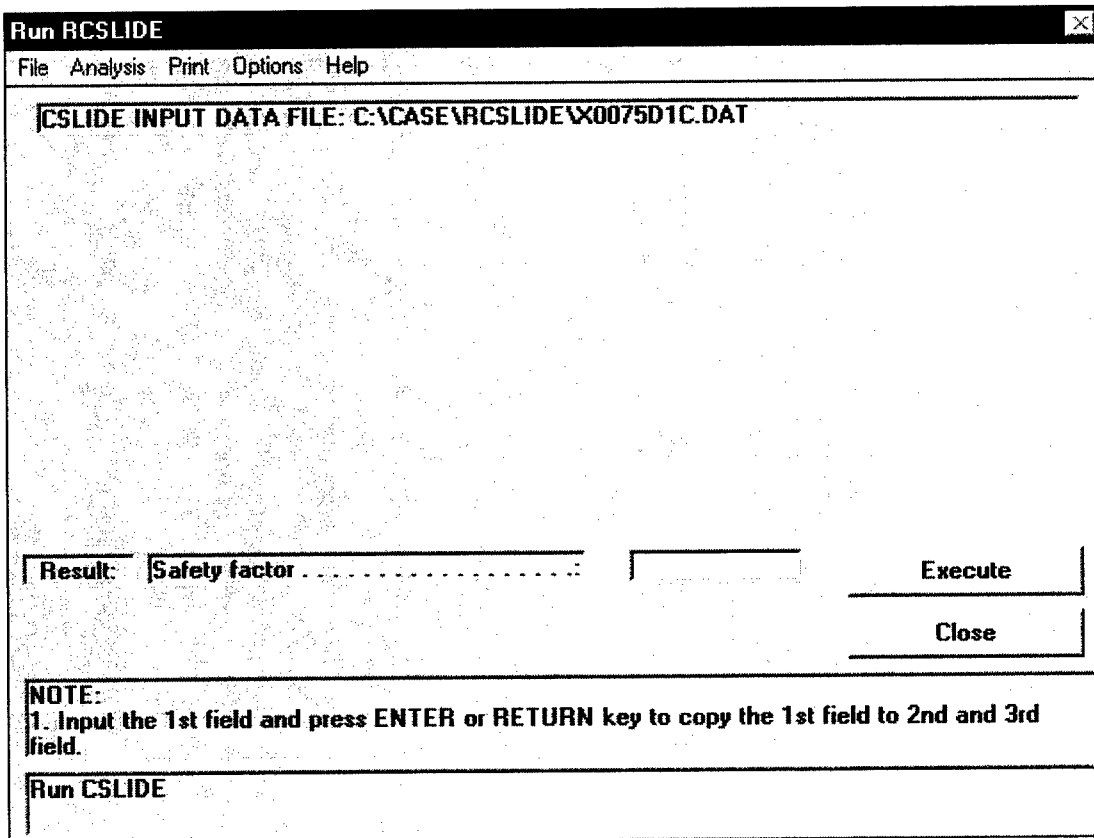

Figure 68. RC SLIDE Default Execution screen

- (1) **Debug.** Used to obtain a listing of the results from each iteration of the CSLIDE analysis in the CSLIDE output file. This option is not available when a reliability assessment is performed.
 - (2) **Default.** Used to reassign program default values to the selections on the ASM and simulation execution screens. This option is only available when a reliability assessment is being performed.
- e. *Help.* Displays additional information to assist the user.

Running CSLIDE

The **Execute** button is used to start the CSLIDE analysis that will return the Factor of Safety such as the one shown in Figure 69.

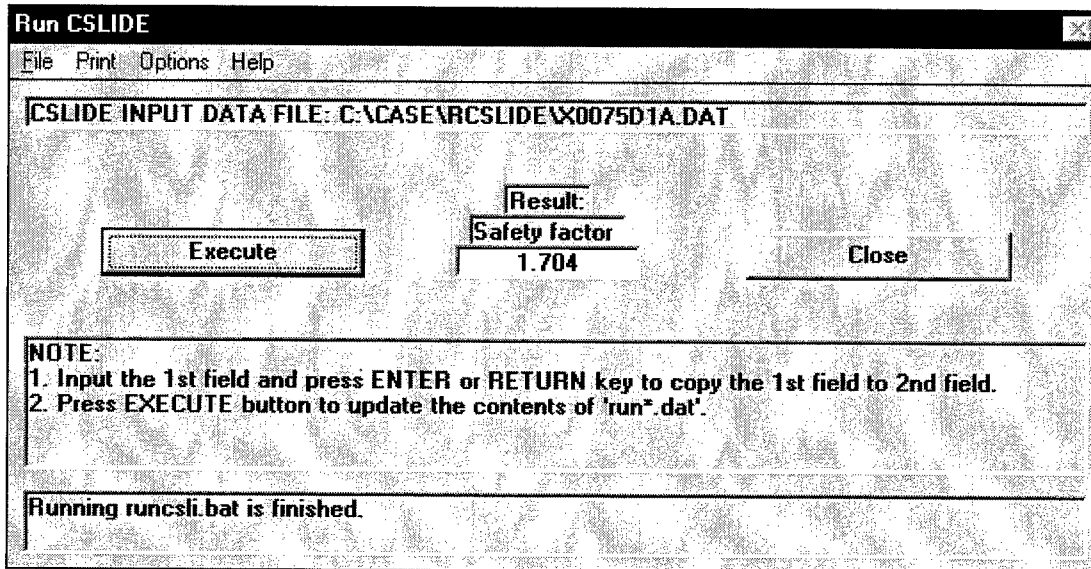

Figure 69. CSLIDE analysis window

Running RCSLIDE

When **Analysis** on the Run RCSLIDE menu bar is selected (Figure 70), the following methods of analysis are provided:

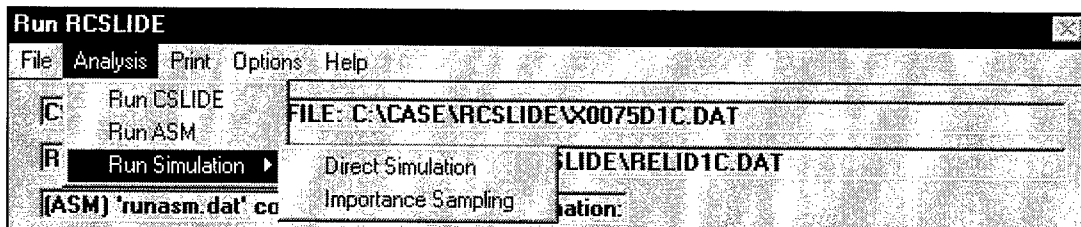

Figure 70. Analysis pull-down menu

- a. *Run CSLIDE*: the default, as previously described in this chapter.
- b. *Run ASM*: advanced second moment method of reliability assessment.
- c. *Run Simulation-Direct Simulation*: direct Monte Carlo method of reliability assessment.
- d. *Run Simulation-Importance Sampling*: Monte Carlo simulation using importance sampling as the reliability assessment method.

When performing an assessment, RCSLIDE provides these options to return the safety factor, reliability index, and the probability of unsatisfactory performance.

As previously described in this chapter, the Run CSLIDE method will return only a safety factor (Figure 71).

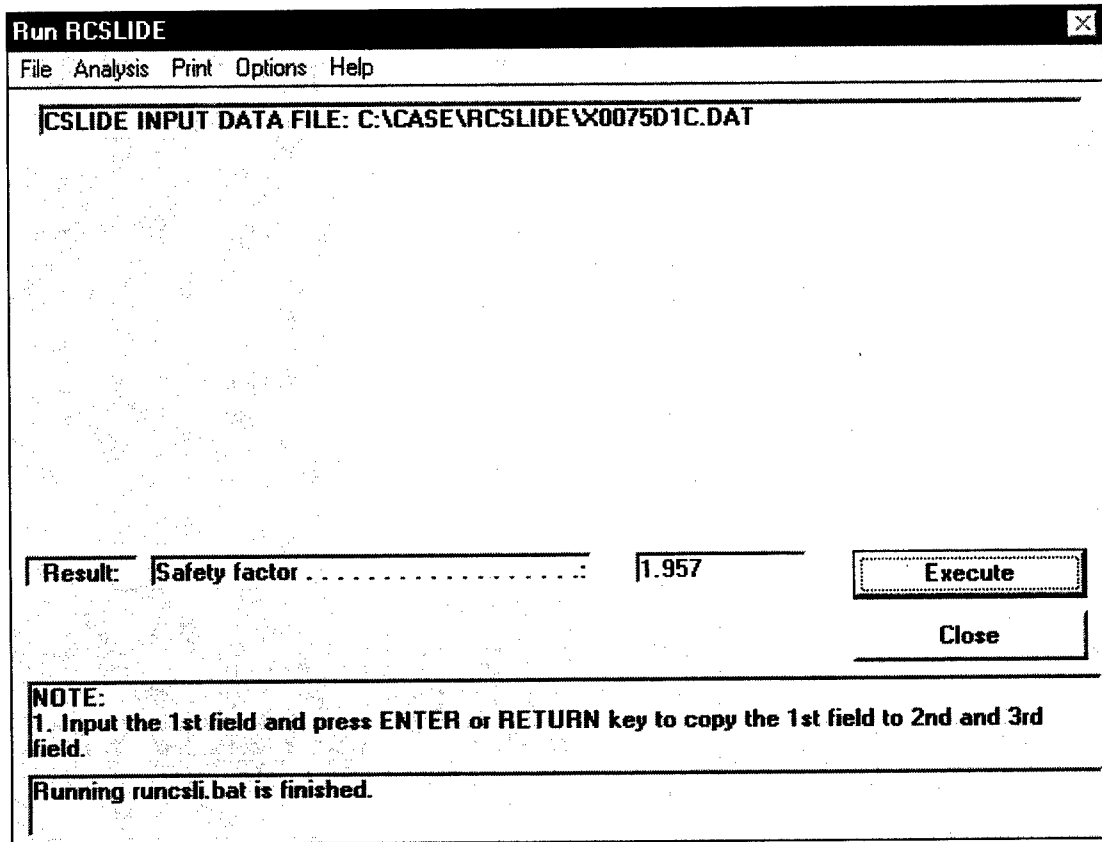

Figure 71. CSLIDE analysis window from RCSLIDE – default screen

When the user selects the **Run ASM** option, the program displays several additional fields as shown in Figure 72.

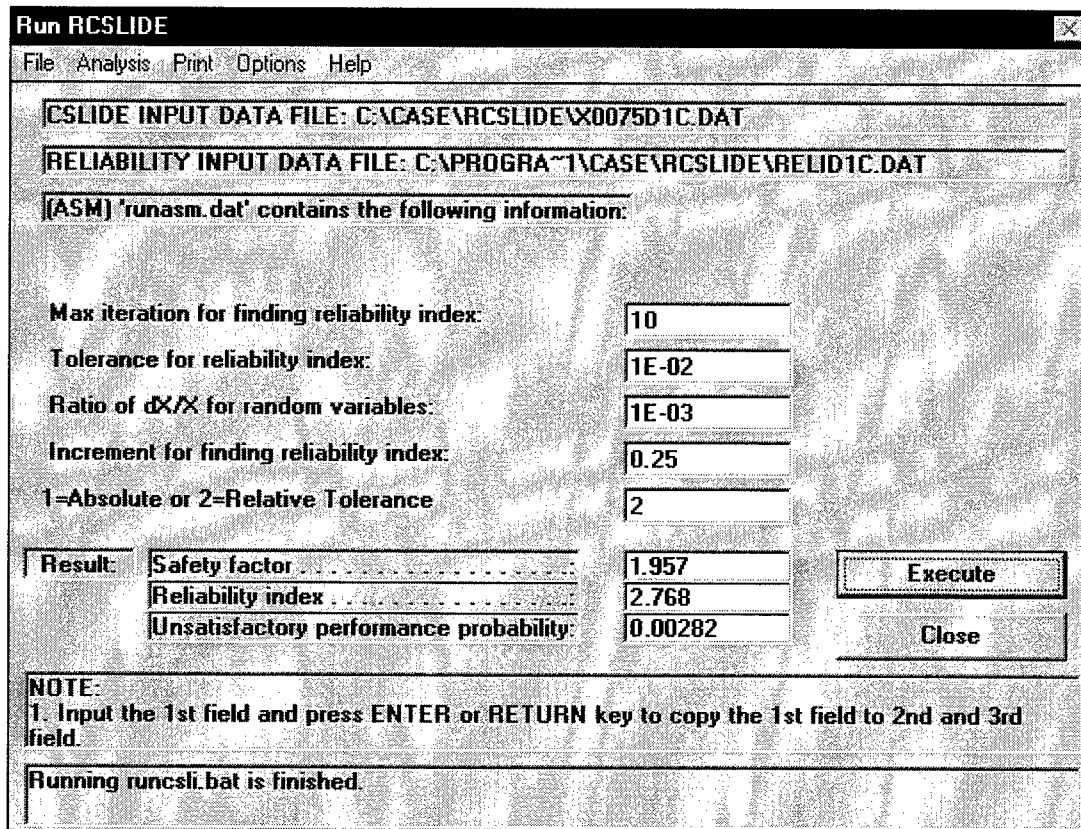

Figure 72. Run ASM

This analysis type allows the user to perform a reliability assessment using the advanced second moment method. It displays the following additional fields:

- a. *Maximum iteration for finding reliability index.* Allows the user to specify the maximum number of iterations for use when computing the reliability index (β). Default value is 10.
- b. *Tolerance for reliability index.* Allows the user to specify a tolerance value to use when computing the reliability index (β). Default value is 0.01, that is, when $|\beta_i - \beta_{i-1}| \leq 0.01$, β_i is the answer.
- c. *Ratio of dX/X for random variables.* Permits the user to define the ratio of a small quantity ΔX to its own value X for each random variable. Default value for this ratio is 0.001. This value is used to compute the partial derivative in calculating directional cosines using ASM. The small quantity $\Delta X = \text{ratio} * X$. The derivative is defined as $\lim_{\Delta X \rightarrow 0} \frac{f(X + \Delta X) - f(X)}{\Delta X}$.
- d. *Increment for finding reliability index.* Specifies the increment (ΔX) to be used for finding the reliability index.

- e. 1 = Absolute or 2 = Relative tolerance. Specifies the type of tolerance for calculation the reliability index. If this value is 1, then the tolerance value defined above is treated as an absolute tolerance; if this value is 2, then it is treated as a relative tolerance. The relative tolerance is defined as

$$\frac{|\beta_i - \beta_{i-1}|}{|\beta_i|}$$

Run ASM method of reliability assessment will return a CSLIDE factor of safety, the reliability index, and the probability of unsatisfactory performance.

If the user selects the **Run Simulation – Direct Simulation** method of analysis, a Monte Carlo simulation method is used to perform the reliability assessment. The program displays the following additional fields as shown in Figure 73.

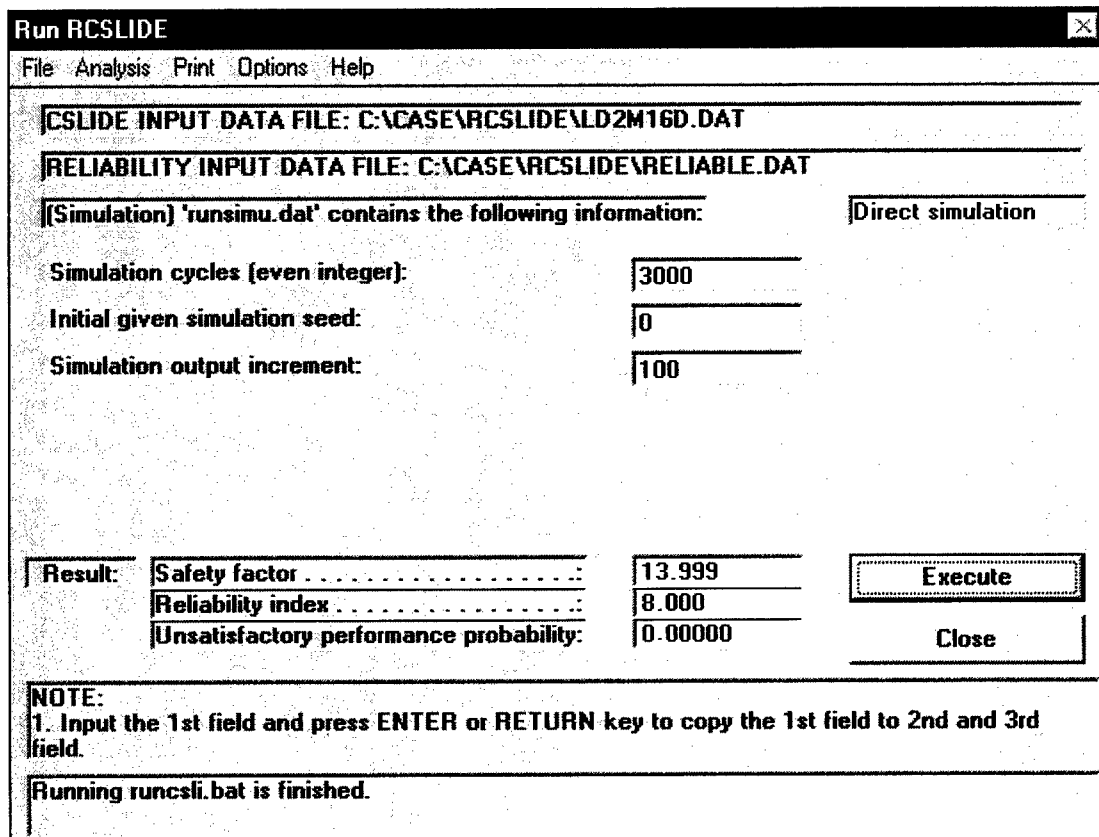

Figure 73. Run Simulation - Direct Simulation execution screen

- a. *Simulation cycles (even integer)*. This value specifies the number of cycles for which the simulation will be performed. It must be an even integer value, and the default value is 1000.

- b. *Initial given simulation seed.* Allows the user to specify a simulation seed value. If this value is set at the default value of 0, the program calculates a seed value based on the computer clock time.
- c. *Simulation output increment.* Specifies the increment at which simulation results will be listed in the output file. Default value is 10.

As with the advanced second moment method of reliability analysis, the program will produce a CSLIDE factor of safety, a reliability index, and a probability of unsatisfactory performance.

Selection of the **Run Simulation – Importance Sampling** method of analysis will result in a simulation technique using importance sampling to perform fields as shown in Figure 74 when the method is chosen.

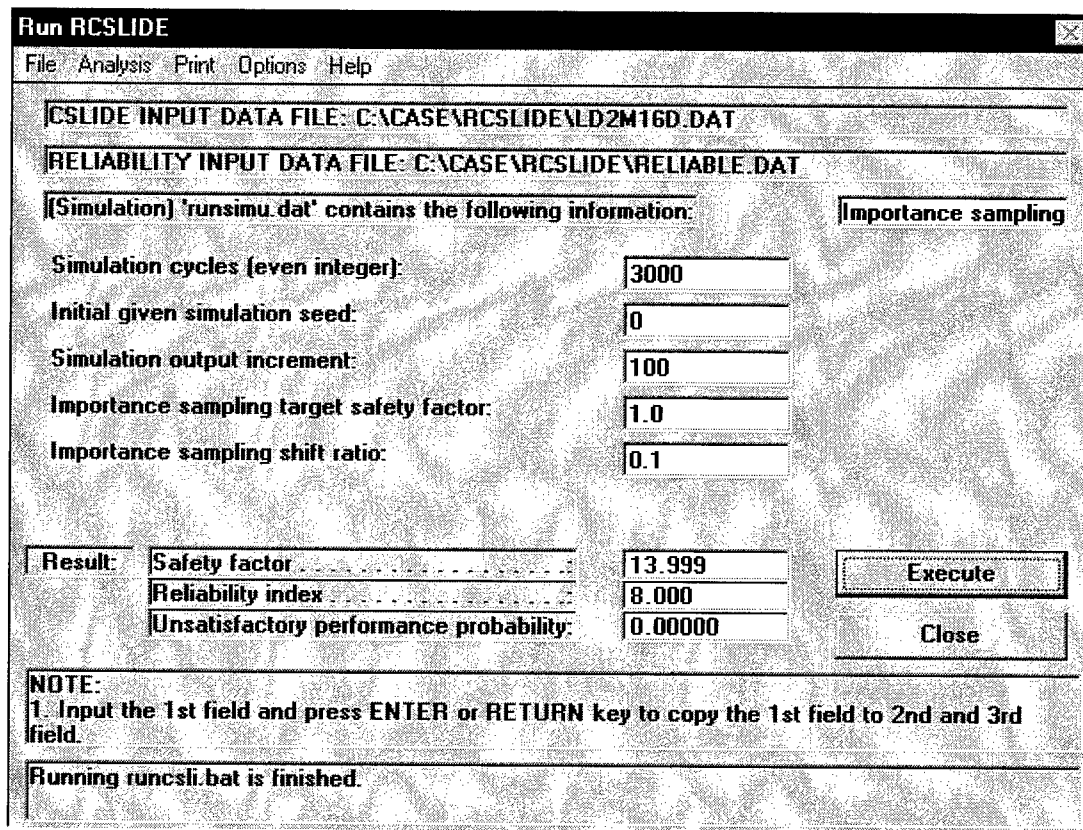

Figure 74. Run Simulation – Importance Sampling execution screen

- a. *Simulation cycles (even integer).* This value specifies the number of cycles for which the simulation will be performed. It must be an even integer value, and the default value is 1000.
- b. *Initial given simulation seed.* Allows the user to specify a simulation seed value. If this value is set to the default value of 0, the program calculates a seed value based on the computer clock time.

- c. *Simulation output increment.* Specifies the increment at which simulation results will be listed in the output file. Default value is 10.
- d. *Importance sampling target safety factor.* This value is the target for shifting the safety factor in importance sampling, and the default value is 1.0.
- e. *Importance sampling shift ratio.* Specifies the ratio for shifting the safety factor to the target value. Default value is 0.1.

Output Files

Examples of the various output files can be found in Appendixes B and C.

CSLIDE analysis output

The CSLIDE output file produced by either a CSLIDE or a RCSLIDE execution contains the following information about each problem:

- a. Input data in report format.
- b. Vertical and horizontal loads on all wedges.
- c. Water pressures at the vertices of all wedges.
- d. Failure angles of all wedges.
- e. Total and submerged lengths of all wedges.
- f. Weights of all wedges.
- g. Uplift forces on all wedges.
- h. Net force on all wedges.
- i. Factor of safety.

Advanced second moment output

Both the compact and detailed output files contain the following information:

- a. Initial mean, standard deviation, coefficient of variation, and distribution type for each random variable.
- b. Reliability index computed at each iteration.
- c. Directional cosines, partial safety factors, and design point calculated for each random variable at each iteration.

- d. Probability of unsatisfactory performance.

In addition to the above list, the detail report also contains the moments of the equivalent normal distribution, partial derivatives evaluated at the design point, and reliability index range for each random variable at each iteration.

Simulation output

The output file generated by a direct Monte Carlo simulation or by importance sampling contains the following:

- a. Initial mean, standard deviation, coefficient of variation, and distribution type for each random variable.
- b. Mean and variance of the estimated unsatisfactory performance probability at each reported iteration.
- c. Minimum and maximum safety factor.
- d. Reliability index.
- e. Statistics for the probability of unsatisfactory performance.

Also included in the importance sampling output file is the value of the shifted mean and the ratio of the mean to the shifted mean for each random variable, simulation, and sample mean statistics for the probability of unsatisfactory performance including biased variance computations.

Saving the Results

Input data files and output analysis files may be saved by a variety of mechanisms.

Run file menu

After a CSLIDE or RCSLIDE analysis has been performed, **File** pull-down menu on the Run CSLIDE or Run RCSLIDE screen can be displayed as shown in Figure 75.

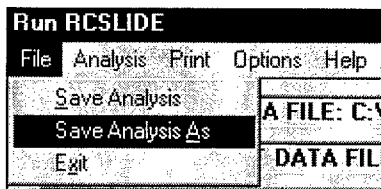

Figure 75. Run-File pull-down menu

Save Analysis As. This selection will result in the appearance of the dialog box, Figure 76, which can be used to save either the input and/or output files. Root filenames, with a maximum of eight characters, may be entered in place of the default names. Each full filename, with its preset extension, is given below the root name. The extensions are as follows:

- dat – for input data files
- out – for CSLIDE analysis output files
- oas – for ASM detailed output files
- ods – for direct simulation output files
- ois – for importance sampling output files
- ras – for ASM compact report output files

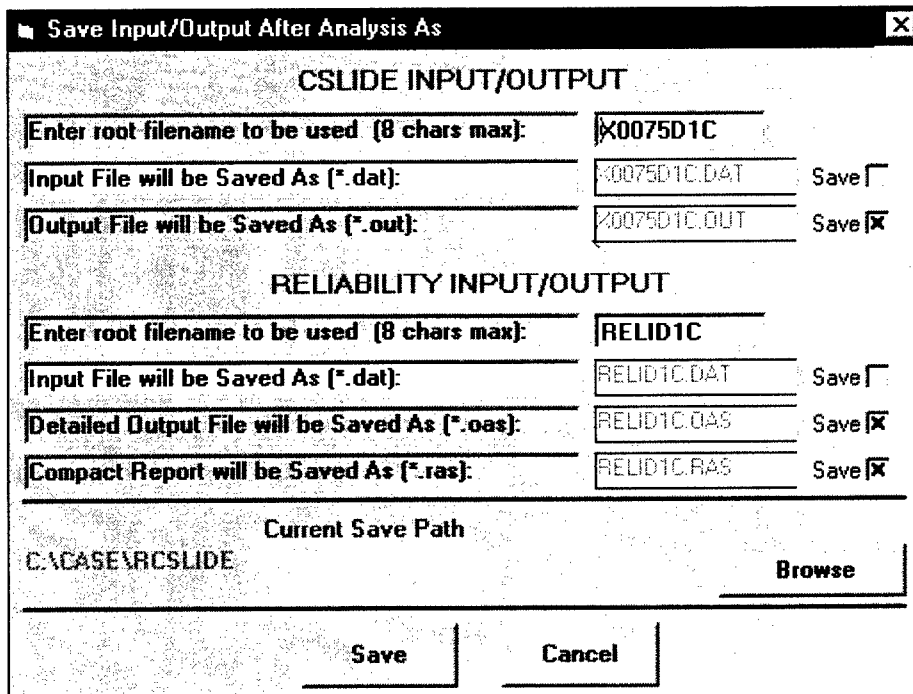

Figure 76. Save Input/Output dialog box

A directory path may be chosen by selecting the **Browse** button and setting the new path. By default only, the output file(s) are saved, but the user can choose which file(s) to save by marking an "X" in the appropriate save box. Files available for saving with each type of analysis are as follows:

CSLIDE – CSLIDE input and output files

ASM – CSLIDE input and output files, reliability input files, and detailed and compact reliability output files

Direct Simulation – CSLIDE and reliability input and output files

Importance Sampling – CSLIDE and reliability input and output files

Save Analysis. Save the current input and output files with their default root filenames and directory path. Defaults are the selections that would appear in the Save Input/Output After Analysis As dialog box.

Exit. If the input and output files have not been saved, this selection will result in the appearance of the dialog box in Figure 77. A **Yes** response will cause Figure 76 to be presented for saving the files; whereas, a response of **No** returns the program to the main screen.

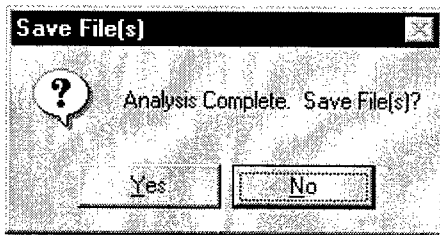

Figure 77. Save Files question dialog box

Run close selection

When the Run CSLIDE/Run RCSLIDE screen is closed after an analysis and the output files have not been saved by one of the above procedures, then Figure 77 will appear as it did with the selection of **File** and then **Exit**.

Performing multiple analysis

Figure 77 will also be revealed when the user has executed one type of analysis and then immediately chooses to perform another type of analysis with the same input data file(s).

Main Menu file selection

CSLIDE and/or reliability input file(s) may be saved by selecting either **Save** or **Save As** on the File pull-down menu from the main menu bar as denoted in Chapters 7 and 9.

Program termination

Upon exiting the program, if the CSLIDE and/or reliability input file(s) have been modified and the modified file(s) have not been saved, then Figure 78 will be presented.

Save and then **Exit** will save the modified data file before program termination. The user then selects a filename and path on the now displayed **Save As** dialog box (Figure 79). **Do Not Save** and then **Exit** will terminate the program without saving the data file. **Cancel** returns the user to the main program.

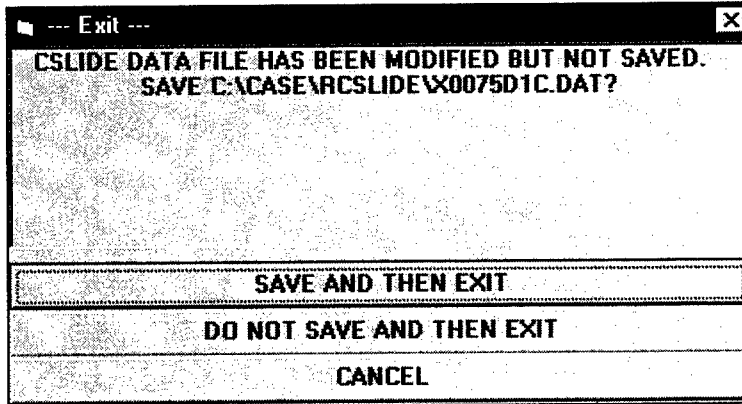

Figure 78. Save Modified Data File dialog box

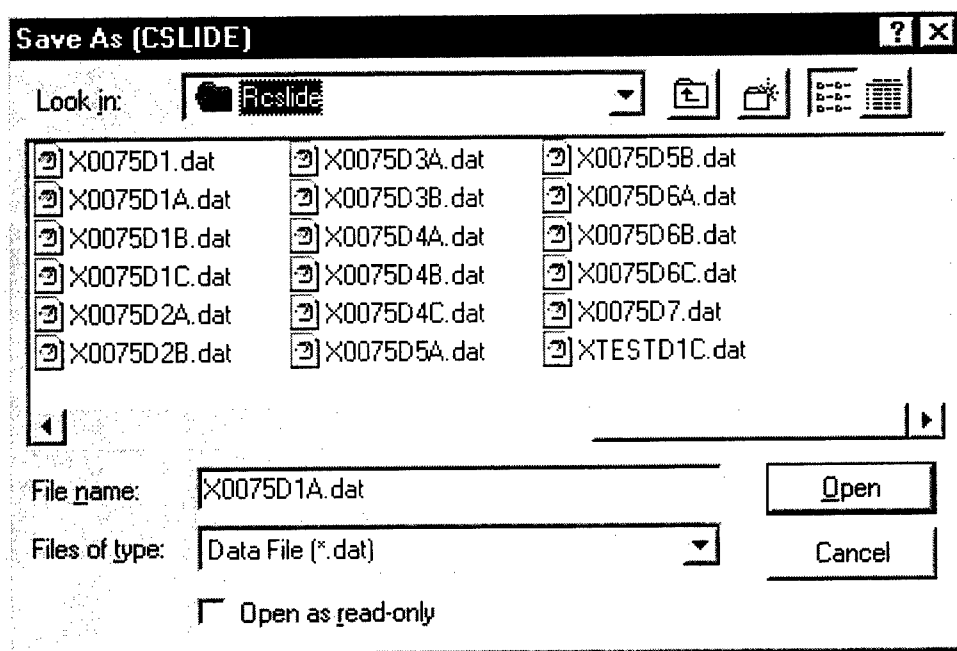

Figure 79. Save As dialog box

Viewing the Results

Using the View menu, users may display a data file or the analysis results. This data must have been previously saved, and the Save Input/Output After Analysis screen (Figure 76) may be utilized for this purpose.

To use this capability, select **View** on the main menu bar, and then select the file type on the pull-down menu as shown in Figure 80. Once the file to be viewed is selected on the View screen (Figure 81), it will be displayed in a scrollable window as shown in Figure 82.

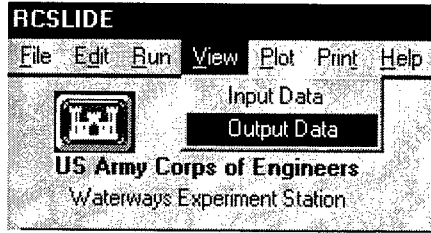

Figure 80. View pull-down menu

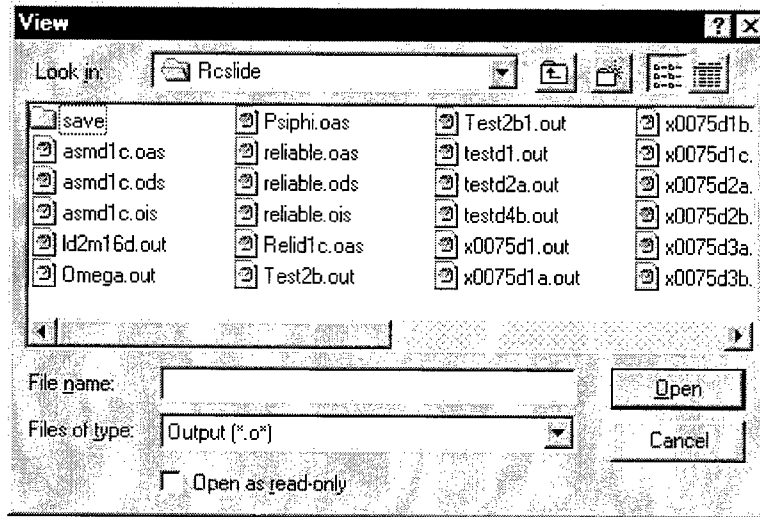

Figure 81. View file selection screen

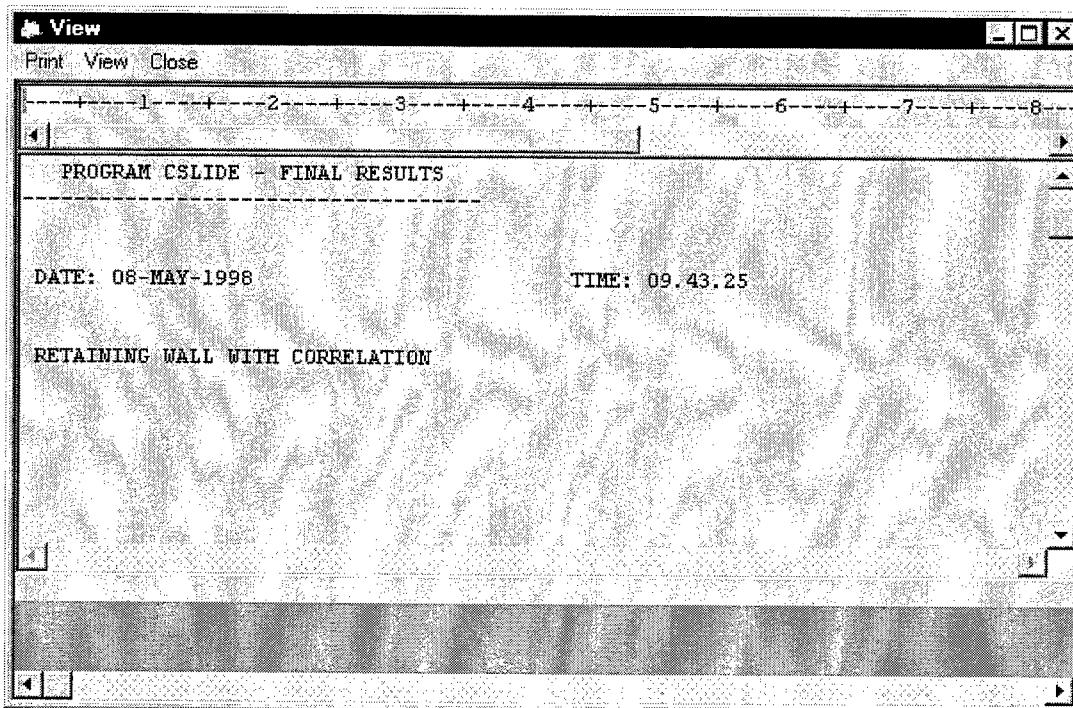

Figure 82. Results displayed in view window

The selections on the View screen menu bar are as follows:

Print – Used to print the selected file (File) or a copy of the current screen (Form) (Figure 83).

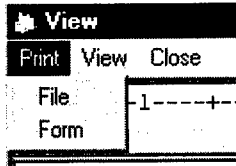

Figure 83. View-Print pull-down menu

View – Used to display another file (Figure 84). When multiple files are being viewed, they will be exhibited in a cascading window format (Figure 85).

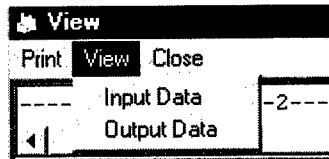

Figure 84. View-View pull-down menu

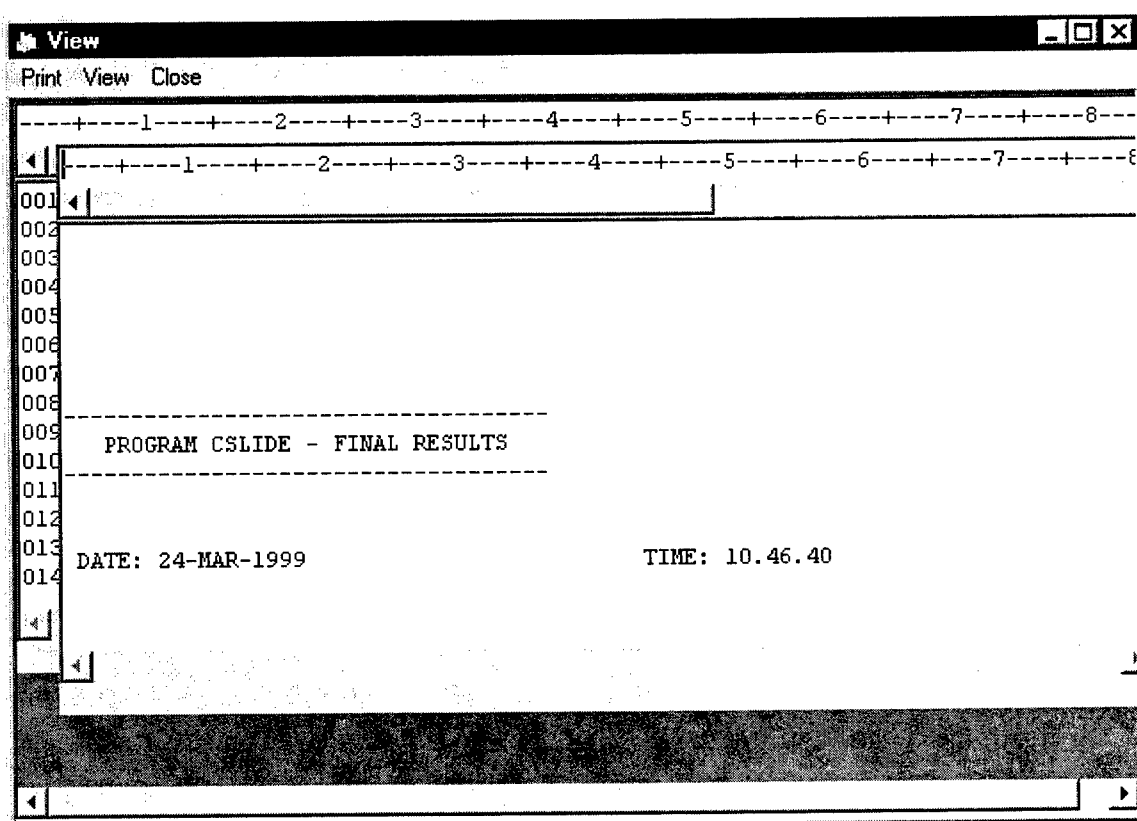

Figure 85. Two view windows open

Close – Terminates the observation of the file in the current view window but does not exit the view screen or exits all windows (Figure 86).

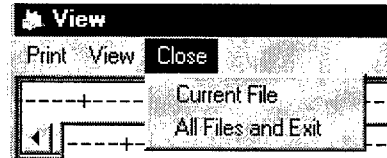

Figure 86. View-Close pull-down menu

Graphical Output

By selecting from the pull-down menu for **Plot** on the main menu bar (Figure 87), both RSCLIDE and CSLIDE allow the user to generate graphical views as follows:

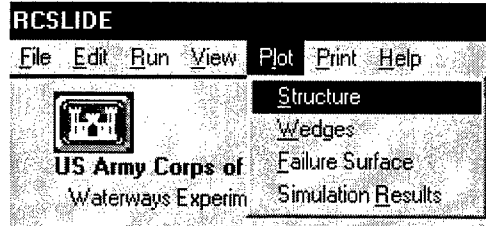

Figure 87. Plot pull-down menu

Figure 88 shows a typical plot of the structural data if **Structure** is selected. The scale factor can be varied to change to size of the plot. The scroll bar can also be used for this purpose.

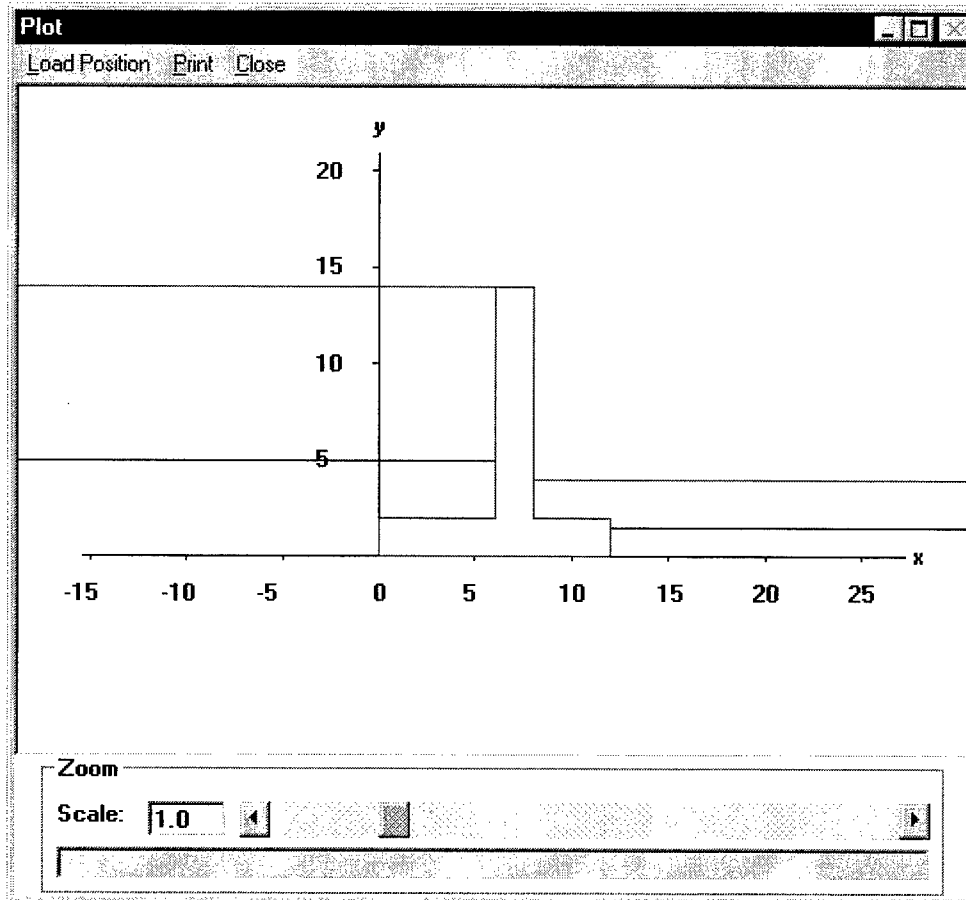

Figure 88. Plot of structure

Structure – input structure. Can only be performed after a CSLIDE input file has been generated or opened.

Wedges – each wedge along with its applied forces. Uses a CSLIDE output file.

Failure Surface – structural failure surface due to sliding. Uses a CSLIDE output file.

Simulation Results – mean probability of unsatisfactory performance versus cycle number. Uses an RCSLIDE output file.

Plot window menu commands (see Figure 87) are as follows:

Load Position (Figure 89)

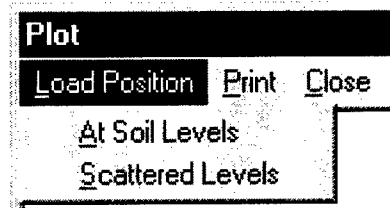

Figure 89. Load Position pull-down menu on Plot window

At Soil Levels – displays loads at the soil levels (Figure 90)

Scattered Levels – displays loads at random levels (Figure 91)

Print – Print Form – prints a copy of the current window

Close – Close Plot – exits the plot screen

The program prompts the user for the output file to use and displays the left-side, structural, and right-side wedges when **Plot** then **Wedges** is chosen. Each wedge is plotted from data stored in the CSLIDE output file. Figure 92 shows a left-side wedge plot.

Function of the items on the Wedge Plot menu bar are (see Figure 92) as follows:

Previous – switches to the plot before the current one

Next – switches to the plot after the current one

Print – prints the current window

Close – exits the plot window

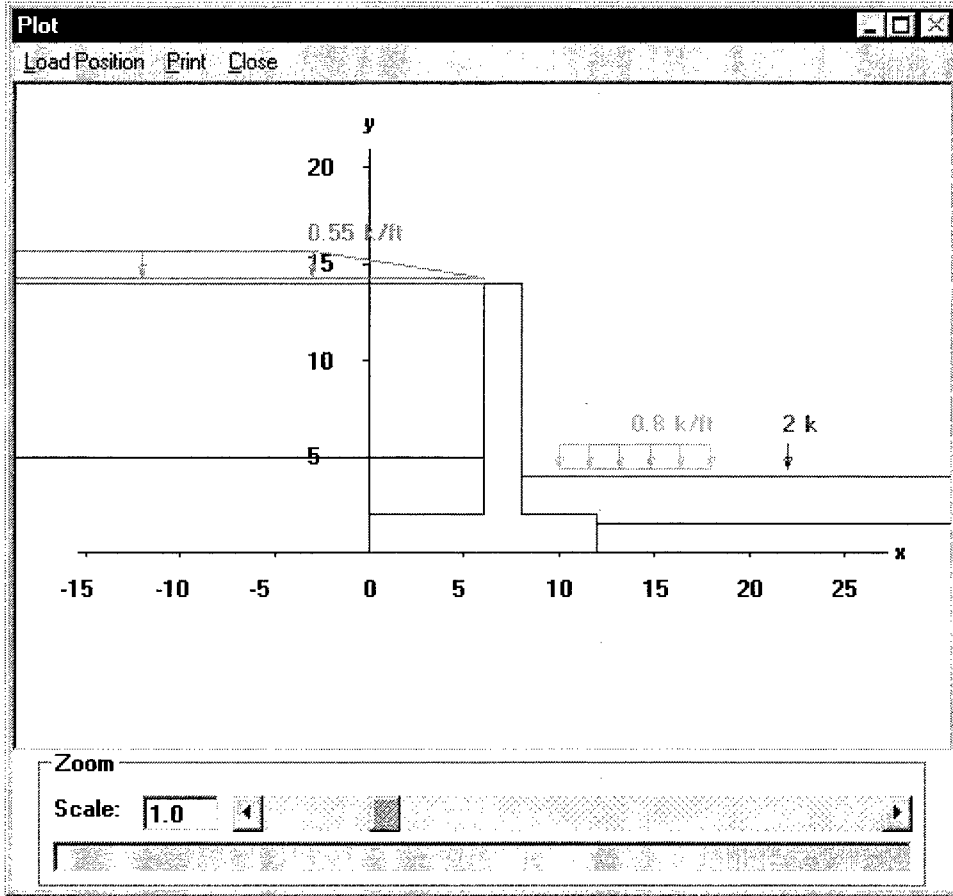

Figure 90. Loads plotted at soil level

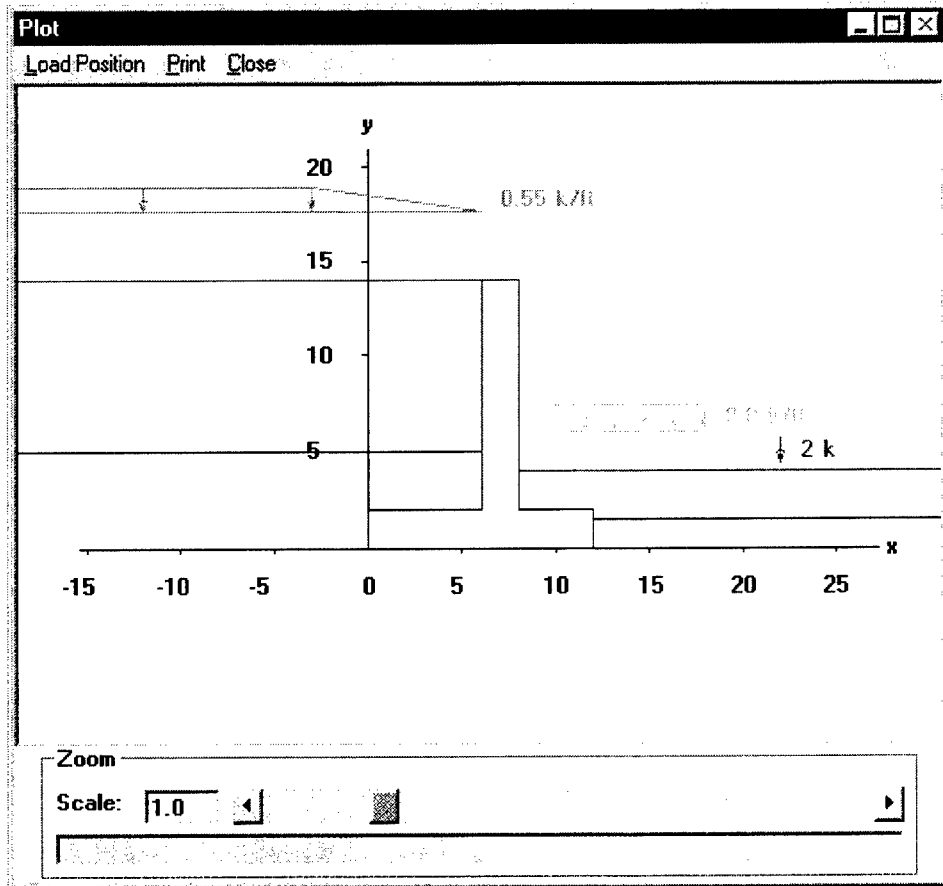

Figure 91. Loads plotted at scattered levels

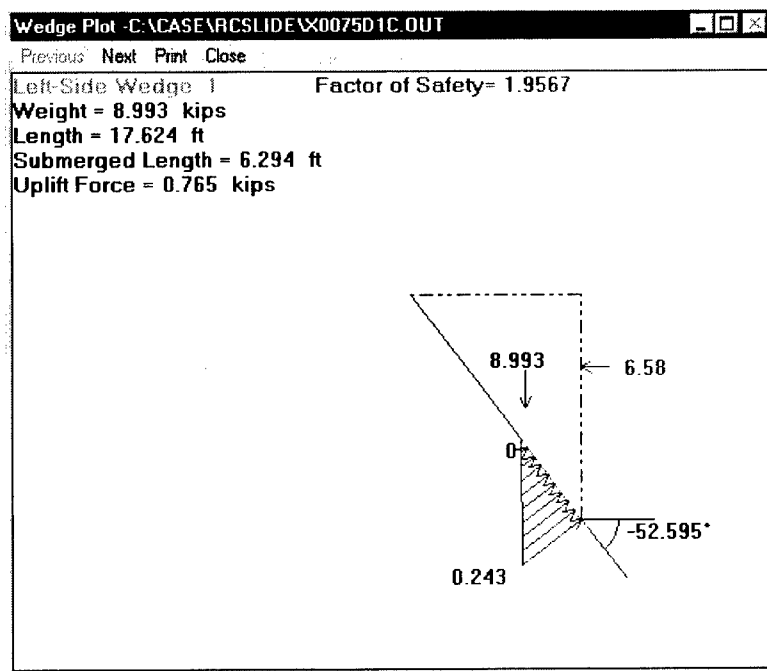

Figure 92. Example of CSLIDE's wedge plotting

When a failure surface plot is requested, the program prompts the user for an output file to use and then displays the structural failure surface due to sliding. A sample failure surface plot is given in Figure 93.

In addition to providing plots of the structure and wedges, a plot of the RCSLIDE of simulation results may be displayed as shown in Figure 94 when **Plot** then **Simulation Results** is selected. This option is only available for RCSLIDE, and the simulation results can either be from an importance sampling or a direct Monte Carlo simulation run.

Plot Simulation curve menu bar functions are (see Figure 94) as follows:

Plot File – Plot Simulation Curve – used to select another simulation curve to plot.

Type (Figure 95)

Line – plots data points as a connected line (Figure 94)

Scatter – plots unconnected data points (default type) (Figure 96)

Print – Print Form – prints current window

Close – exits the plot window

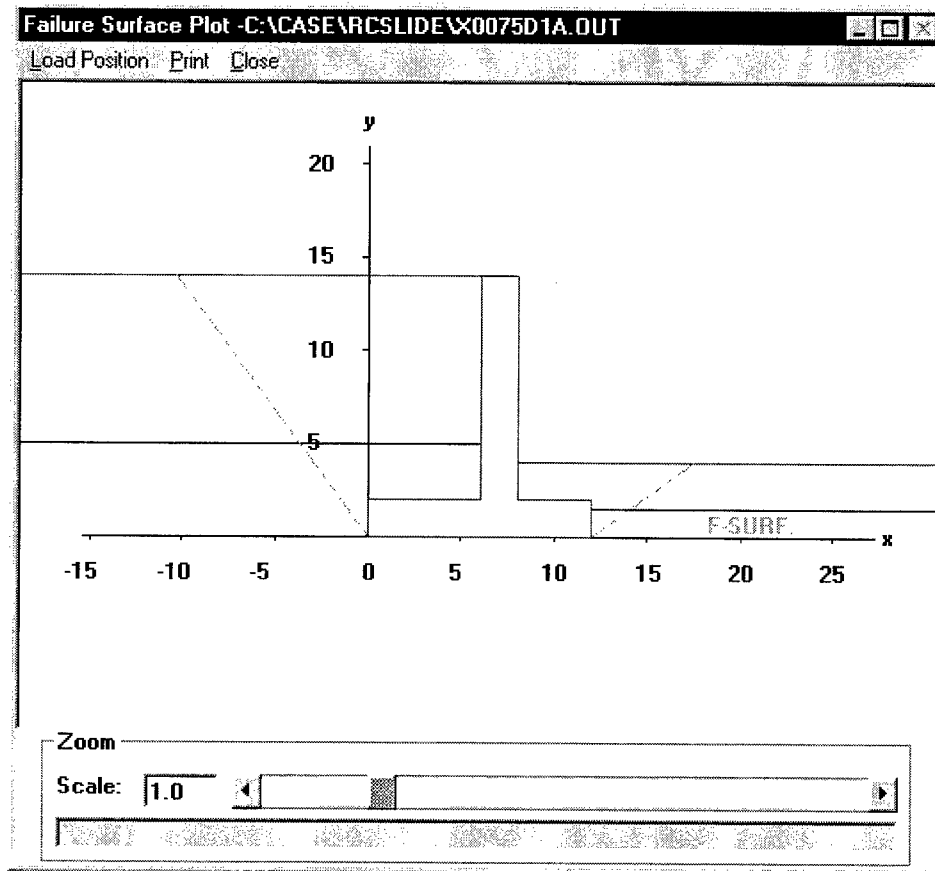

Figure 93. Failure Surface Plot – Problem 1A

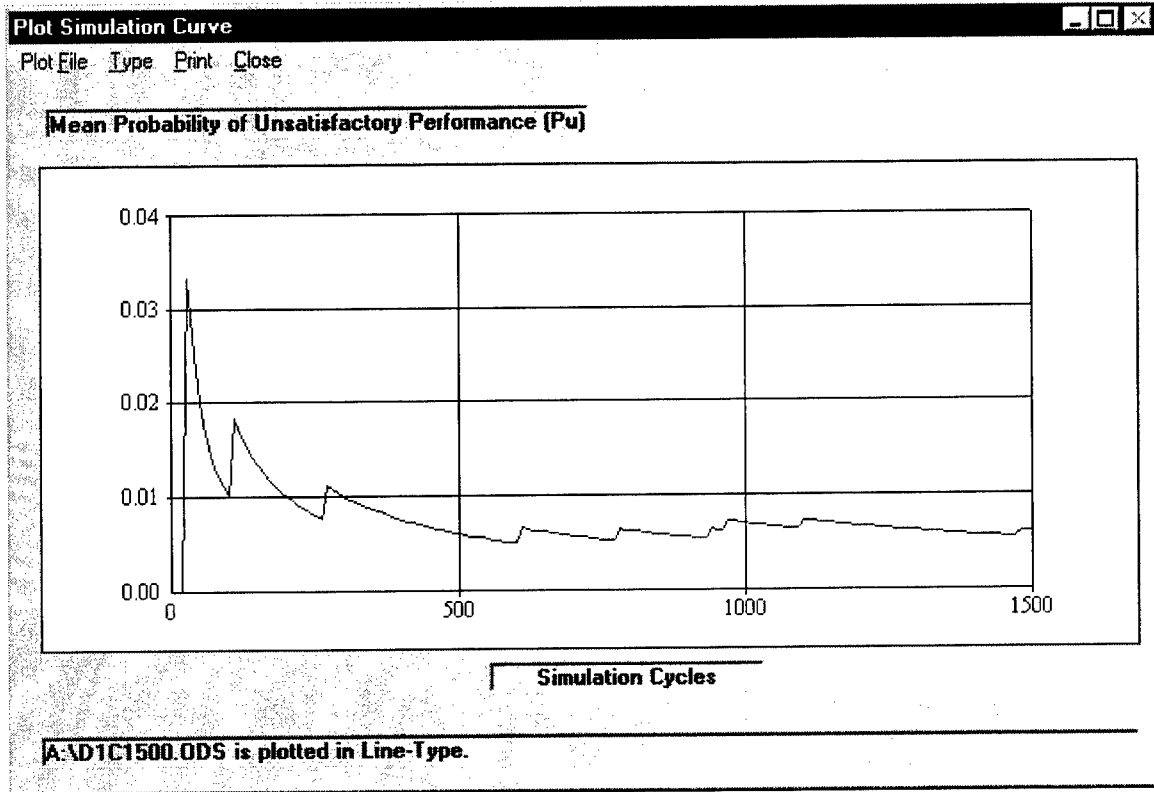

Figure 94. Plot of simulation results (Type = Line)

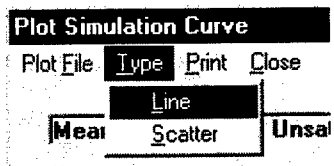

Figure 95. Type pull-down menu on Plot simulation curve window

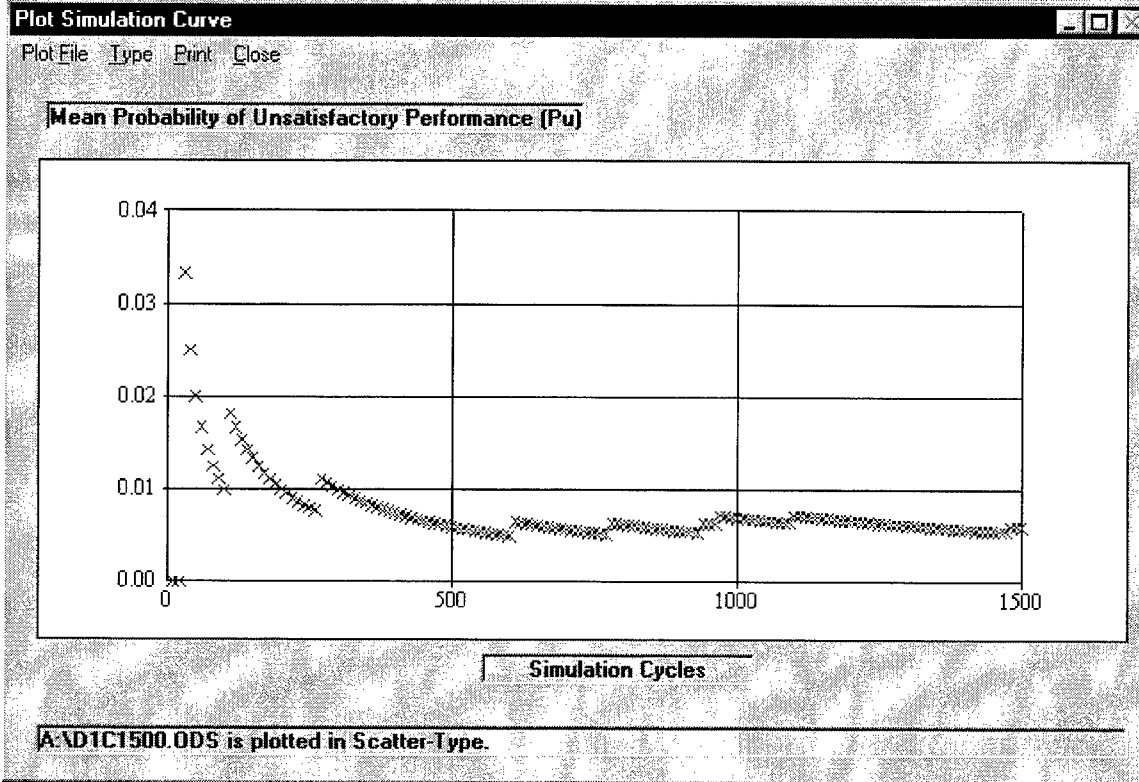

Figure 96. Plot of simulation results (Type = Scatter)

References

- Ayyub, B. M., and Chao, R. -J. (1994). "Probability distributions for reliability-based design of naval vessels," CARDEROCKDIV-U-SSM-65-94/12, Naval Surface Warfare Center, U.S. Navy, Carderock Division, Bethesda, MD.
- Ayyub, B. M., Chao, R. -J., Patev, R. C., and Leggett, M. A. (1998). "Reliability and stability assessment of concrete gravity structures (RCSLIDE): Theoretical manual," Technical Report ITL-98-6, U.S. Army Engineer Waterways Experiment Station, Vicksburg, MS.
- Headquarters, U.S. Army Corps of Engineers. (1981). "Sliding stability for concrete structures," Engineer Technical Letter 1110-2-256, Washington, DC.
- _____. (1995a). "Earthquake design and evaluation of Civil Works Projects," Engineer Regulation 1110-2-1806, Washington, DC.
- _____. (1995b). "Gravity dam design," Engineer Manual 1110-2-2200, Washington, DC.
- _____. (1997). "Stability analysis of concrete structures," Engineer Circular 1110-2-291, Washington, DC.
- Wolff, T. F., and Wang, W. (1992). "Engineering reliability of navigation structures," Contract Report ITL-92-4, U.S. Army Engineer Waterways Experiment Station, Vicksburg, MS.

Appendix A

Sliding Stability (CSLIDE)

Data File

As mentioned in Chapter 8, CSLIDE data files may be created prior to program execution. This appendix describes the data requirements with accompanying figures for illustration.

CSLIDE files created prior to program execution are required to be in a free field format. In addition, the prepared data files must meet the following requirements:

- a. Commas are not allowed as delimiters; data items must be separated by one or more blank spaces.
- b. Integer numbers must be in nondecimal form.
- c. Real numbers may be in decimal form, nondecimal form, or E format.

Data Entry from a File

To create the data file, the user simply types lines of command words and their accompanying data. All lines of data in the data file must be preceded by a line number. Once the data file is created, the user may enter the file by selecting **Open (CSLIDE)** from the program's File menu. A sample data file is

Data file: X0075D1C.dat

```
001 TITL RETAINING WALL with correlation
002 TITL
003 TITL
004 TITL
005 STRU 8 0.15 0.0 1.0
006 0.00 0.00
007 0.00 2.00
008 6.00 2.00
```

```
009 6.00 14.00
010 8.00 14.00
011 8.00 2.00
012 12.00 2.00
013 12.00 0.00
014 SOLT 1 1 28.0 0.05 0.12 14.0
015 -500.00 14.00
016 SORT 1 1 28.0 0.05 0.12 4.0
017 500.00 4.00
018 SOST 30.0 0.05
019 METH 1
020 WATR 5.0 1.5 0.0625
021 END
```

Input Sections

The data file is divided into the following main sections:

- a. Required data.
 - (1) Title.
 - (2) Structural description.
 - (3) Left-side soil description.
 - (4) Right-side soil description.
 - (5) Description of soil below the structure.
 - (6) Method of analysis.
 - (7) Water description.
- b. Optional input.
 - (1) Wedge-angle specification.
 - (2) Earthquake conditions.
 - (3) Safety factor ratio.
 - (4) Vertical surcharge loads.
 - (5) Horizontal loads.
 - (6) Anchor force.
- c. Required.
 - (1) Termination.

Input Syntax

The following explains the syntax used to describe a data file's command words, variables, requirements, and restrictions.

- a. Brackets, [], indicate the enclosed variable is optional. All optional variables have default values or no values, as listed. (Do not include the brackets when entering the optional variables.)
- b. [LN] indicates that a line number is used in this location only when a data file is being created.
- c. Quotation marks indicate the enclosed alphabetic term is to be typed exactly as given, but without the quotation marks.
- d. If any keyword line requires more than one data line, the additional lines should immediately follow the keyword line.
- e. All data items must be separated by one or more blank spaces. Do not separate data with commas or any other character.

Refer to the Table 1 of Chapter 8 for a summary of units and sign conventions.

Required Data Description

Four sections of the required data must be entered first and in the following order: Title, Structural information, Left-side soil information, and Right-side soil information.

Title

Contents (maximum four lines)

[LN] "TITL" TITLE

Description

"TITL" keyword for the header line

TITLE any alphanumeric information of user's choice (maximum 70 characters per line)

Structural information

Keyword line

Content (one line)

[LN] "STRU" IPT GAMC [ANEL] [FL]

Description	
"STRU"	keyword for structural information
IPT	number of points describing the structure
GAMC	equivalent unit weight of the structure, kcf
ANEL	elevation of the active wedge failure angle at left side of structure, ft (DEFAULT is the value at the lower left corner of the structure)
FL	percentage of the concrete base of the structure that is in compression; enter a decimal number less than or equal to 1.000 (DEFAULT is 1.000)

When ANEL is entered, it must be at or above the lower left corner of the structure and must be below the top of the bottom soil layer. If FL is entered, ANEL must also be entered.

Data line

Content (maximum 20 points)
 [LN] XC(1) YC(1) XC(2) YC(2)...XC(IPT) YC(IPT)

Description	
XC	x-coordinate of a point describing the structure
YC	y-coordinate of a point describing the structure

Enter the structure points, starting with the lower left corner and proceeding clockwise as shown in Figure A1.

The base of the structure must be represented by a single line. Therefore, any irregularities in the base of the structure must be approximated by a single plane as shown in Figure A2.

Left-side soil description

Keyword line

Content (one line per layer, maximum five layers)
 [LN] "SOLT" NLT LPTS PHIL COL GAML STELL

Description	
"SOLT"	keyword for left-side soil
NLT	soil layer number (one to five; top to bottom)
LPTS	number of points describing layer (excluding the point at the structure)
PHIL	angle of internal friction of the layer, deg
COL	cohesion of the layer, ksf
GAML	saturated or moist unit weight of the layer, kcf
STELL	elevation of the top of the layer where it meets the concrete structure, ft

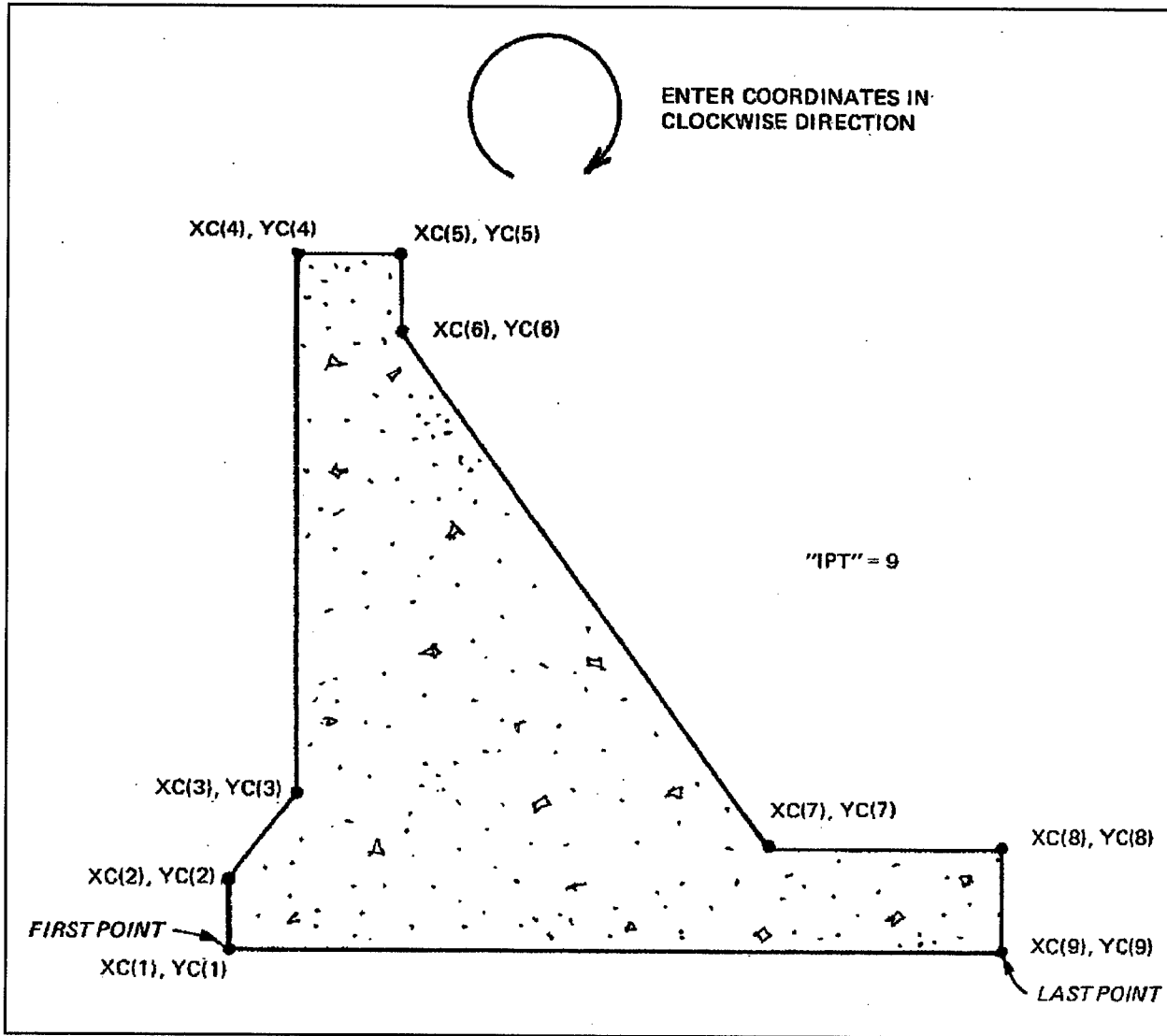

Figure A1. Input of structure coordinates

The soil layers on the left side of the structural wedge always form the active wedges. Figures A3 and A4 indicate valid and invalid entries for the left-side soil layers.

Data Line

Content (maximum of five points per layer; enter for each keyword line)

[LN] XL(1) YL(1) XL(2) YL(2) ...
[LN] ... XL(LPTS) YL(LPTS)

Description

XL x-coordinate of point describing left-side soil layer "NLT"
YL y-coordinate of point describing left-side soil layer "NLT"

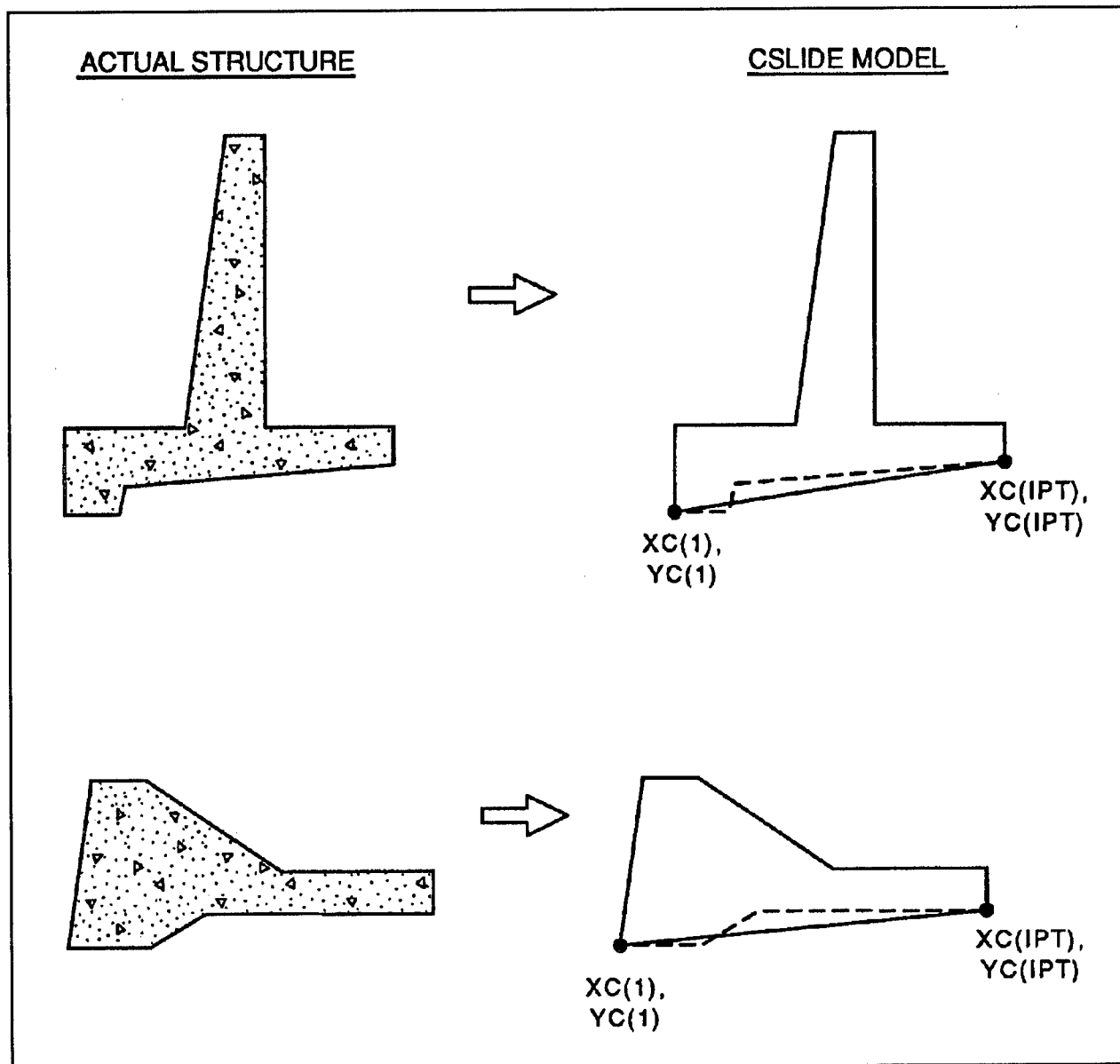

Figure A2. Approximation of irregular base by a single plane

The soil layers are defined from top to bottom. Enter the points describing each soil layer from left to right, excluding the point at the structure as shown in Figure A5. Use as many lines as necessary to enter the coordinate points; however, do not split a coordinate pair (x,y) from one line to the next line.

Right-side soil description

Keyword line

Content (one line per layer, maximum five layers)

[LN] "SORT" NRT RPTS PHIR COR GAMR STELR

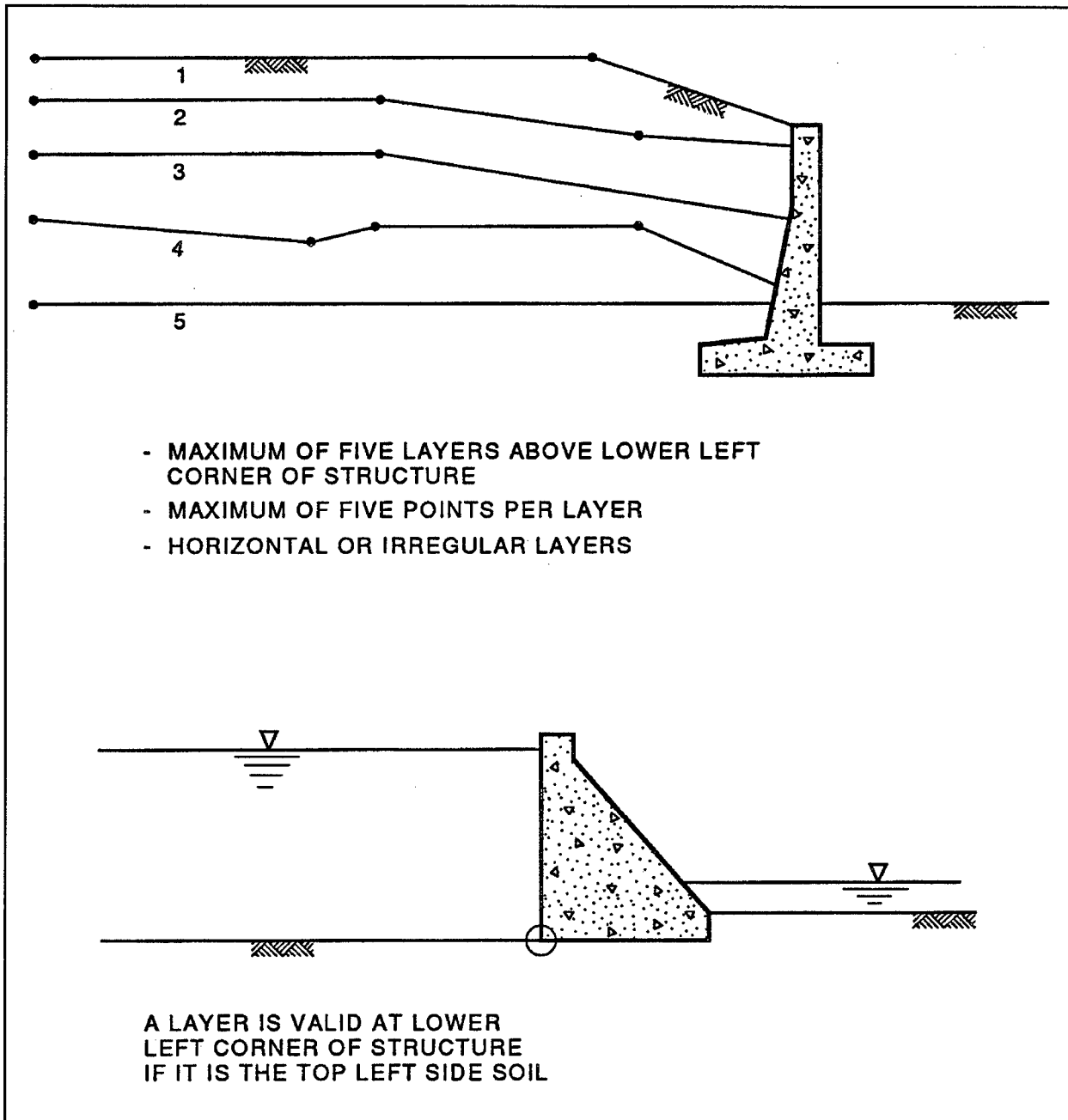

Figure A3. Left-side soil layers (valid entries)

Description	
"SORT"	keyword for right-side soil description
NRT	soil layer numbers (one to five; top to bottom)
RPTS	number of points describing the layer. Exclude the point at the structure
PHIR	angle of internal friction of the layer, deg
COR	cohesion of the layer, ksf

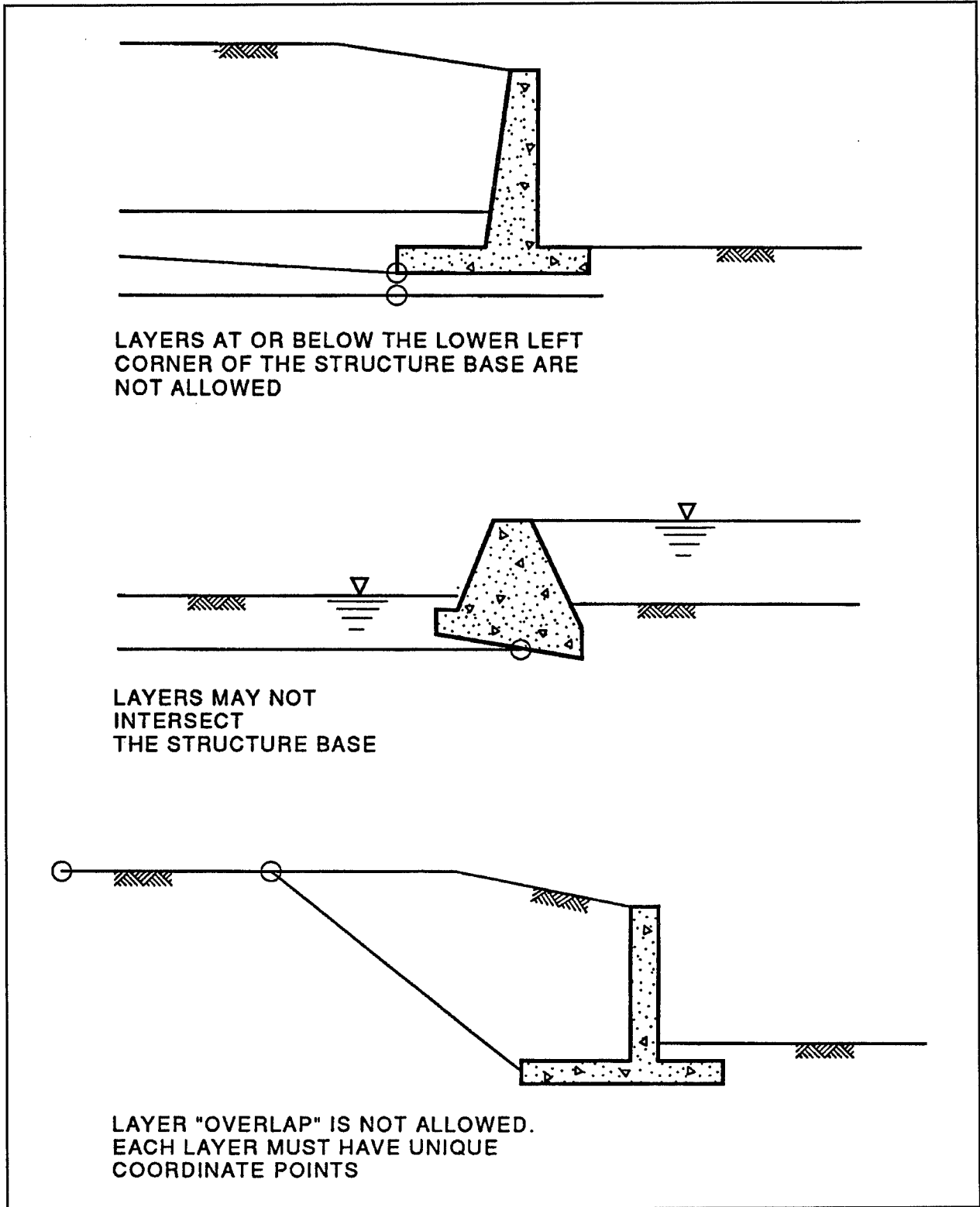

Figure A4. Left-side soil layers (invalid entries)

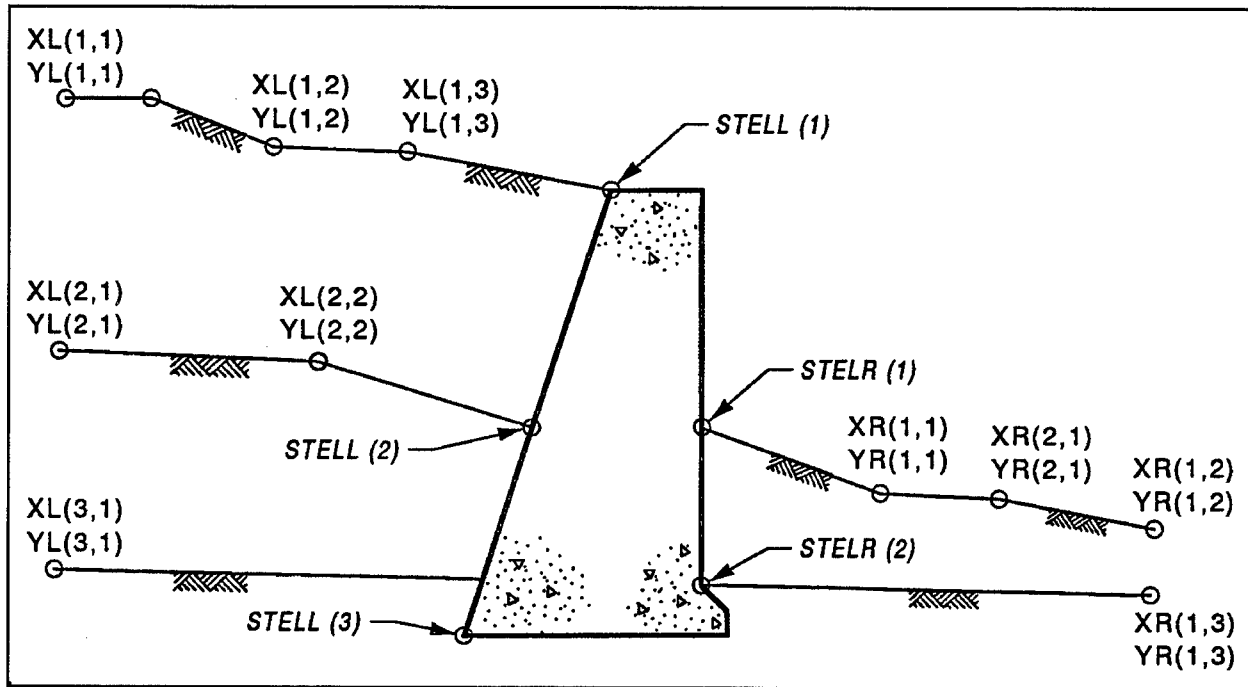

Figure A5. Definition of left- and right-side soil layers

GAMR saturated or moist unit weight of the layer, ksf
 STELR elevation of the top of the layer where it meets the structure, ft

The soil layers on the right side of the structural wedge always form the passive wedges. Figures A6 and A7 indicate valid and invalid entries for the right-side soil layers.

Data Line

Content (maximum of five points per layer; enter for each keyword line)

[LN] XR(1) YR(1) XR(2) YR(2) ...
 [LN] ... XR(RPTS) YL(RPTS)

Description

XR x-coordinate of point describing right-side soil layer "NRT"
 YR y-coordinate of point describing right-side soil layer "NRT"

As for the left-side soil description, the right-side soil layers are defined from top to bottom. Enter the points describing each soil layer from left to right, excluding the point at the structure as shown in Figure A5. Use as many lines as necessary to enter the coordinate points; however, do not split a coordinate pair (x,y) from one line to the next line.

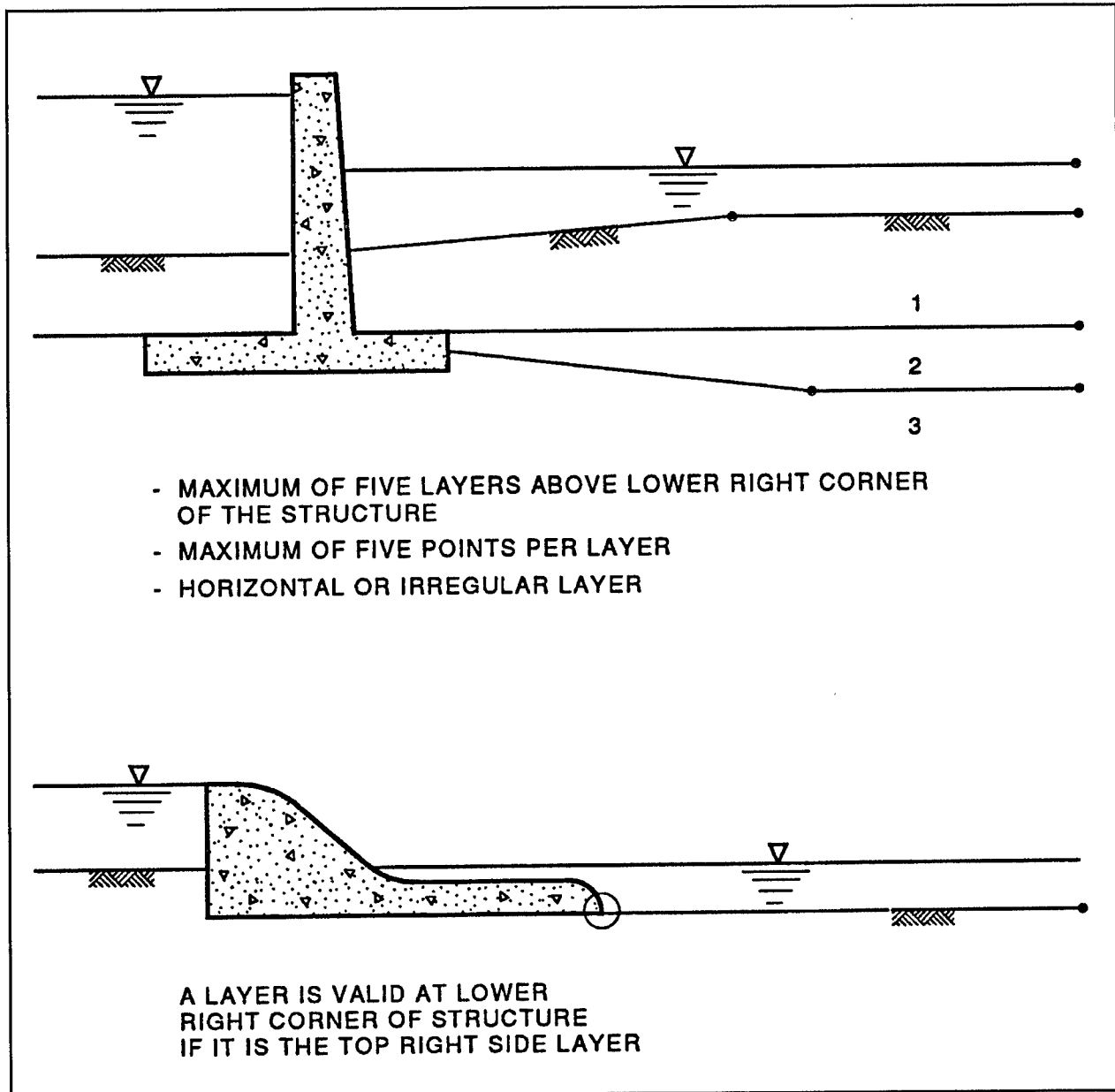

Figure A6. Right-side soil layers (valid entries)

After these four initial sections of required data have been entered in order, the remaining required sections may be entered in any order. The remainder of this appendix presents a description of each required section and each optional section.

Soil below the structure

Content (one line)

[LN] "SOST" PHIC CCS

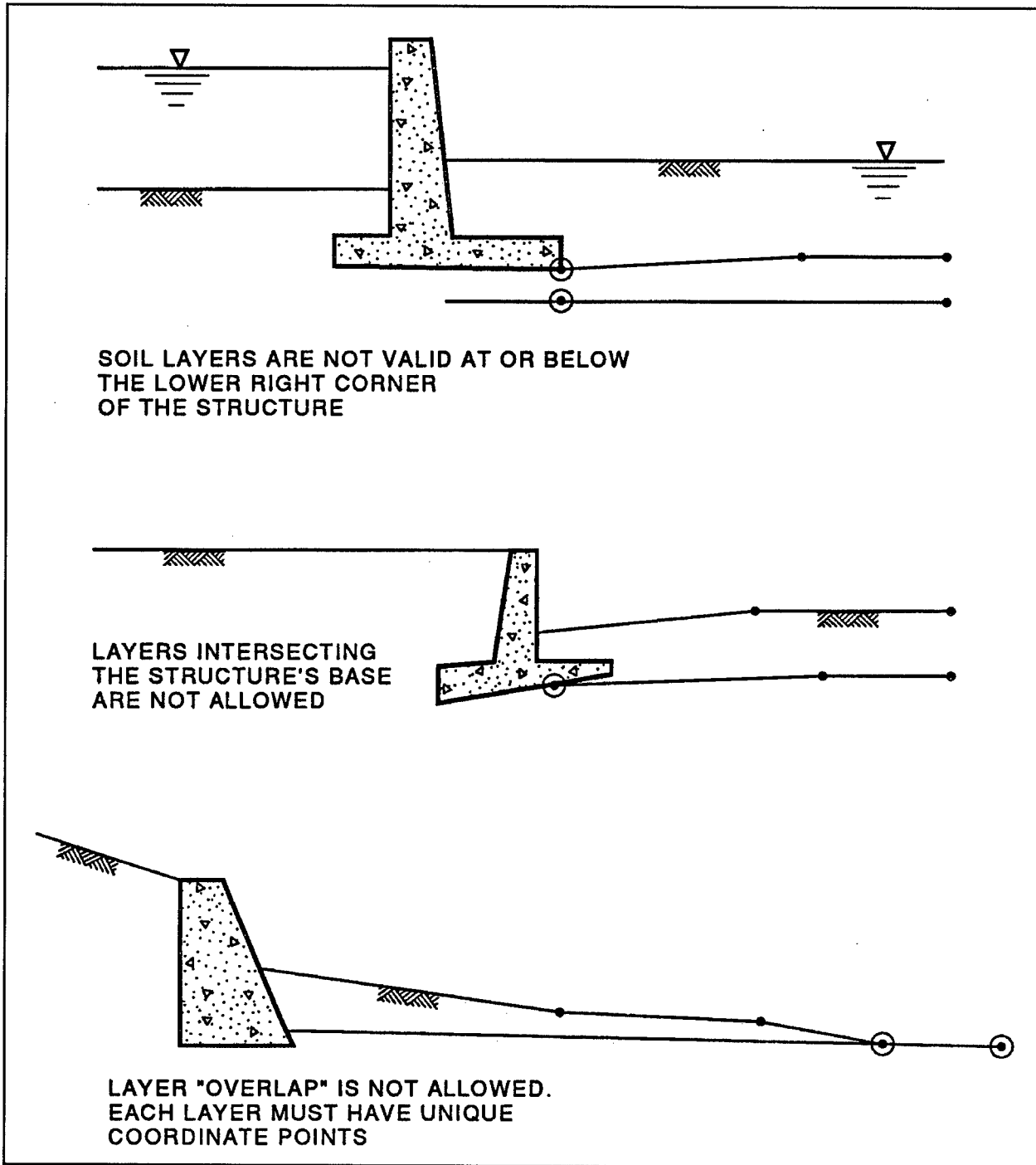

Figure A7. Right-side soil layers (invalid entries)

Description

"SOST"

keyword for the description of the material properties at the interface of the base of the structural wedge and the soil below the structural wedge

PHIC angle of internal friction or angle of base friction, deg
 CCS cohesion or adhesion, ksf

When more than one type of soil comes into contact with the base, PHIC and CS should be represented as an average or equivalent value.

If the base of the structure is part of the failure surface, an angle of base friction and an adhesion value would be used. If the failure surface passes below the base of the structure, the material properties of the soil, an angle of internal friction, and a cohesion value would be used.

Method of analysis

- Content (one line)
 [LN] "METH" MEAN
- Description

"METH"	keyword for the type of layer analysis to be used
MEAN	1 for single-plane analysis 2 for multi-plane analysis

In Method 1 analysis, failure angles are calculated to 0.001 ± 0.0005 deg. In Method 2 analysis, failure angles are calculated to 0.1 ± 0.05 deg, to decrease the number of calculations required by this method. An example of each method is shown in Figure A8.

Water description

Keyword line

- Content line
 [LN] "WATR" WLL WLR GAMW [S] [UC] [EFFD]
- Description

"WATR"	keyword for water description
WLL	left-side water elevation, ft
WLR	right-side water elevation, ft
GAMW	unit weight of water, kcf
S	seepage option -1 for line-of-creep method (calculated along the shortest seepage path) 0 for hydrostatic pressures to be computed 1 for pressures to be entered by the user
UC	uplift force normal to the base of the structural wedge, kips
EFFD	drainage efficiency (E), with range of -1 to 1

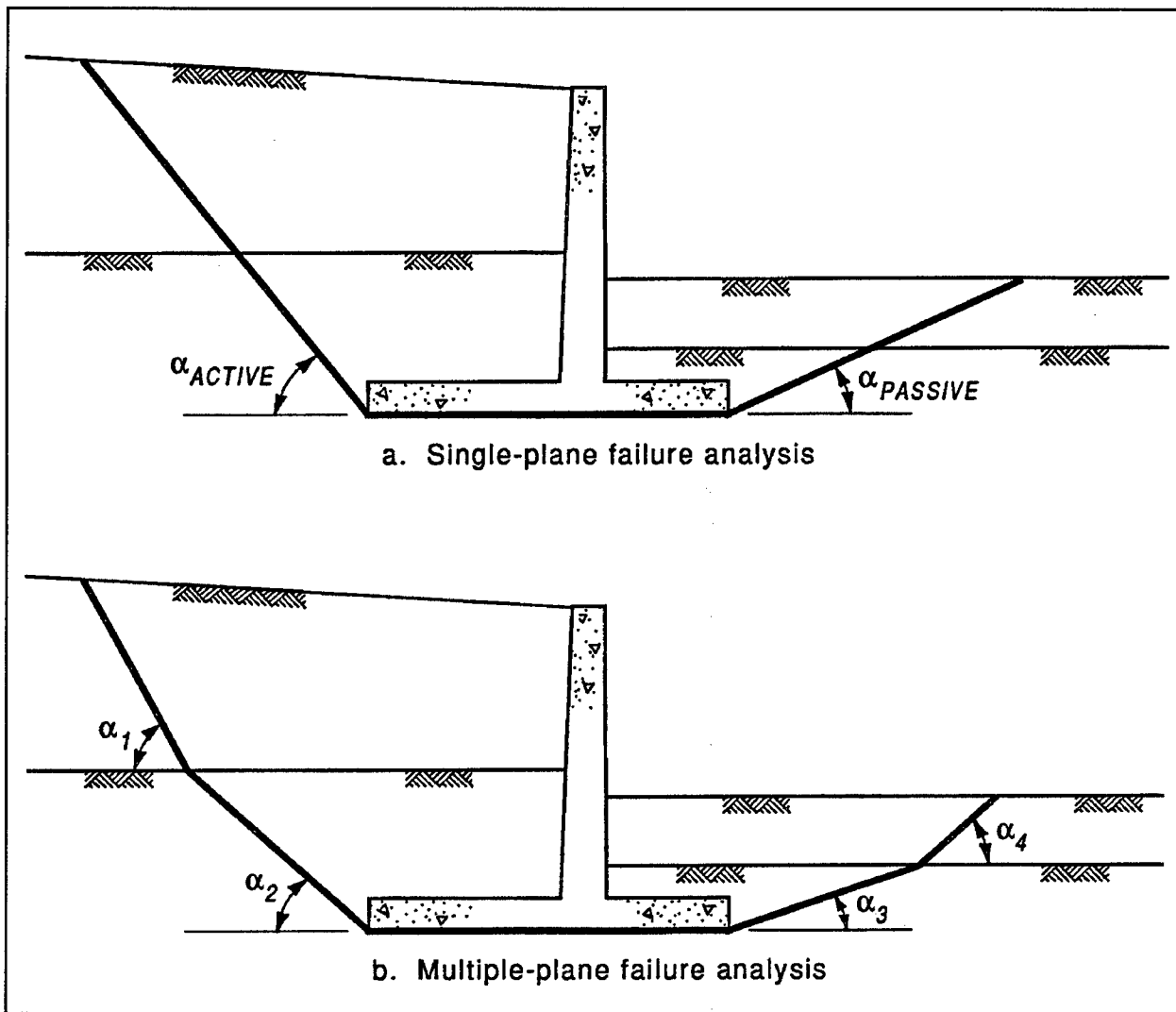

Figure A8. Failure analyses

If a value for S is not entered, the line-of-creep method is used to compute seepage pressures. If the water pressures are hydrostatic, pressures are computed for hydrostatic conditions.

The water elevation may be higher on either side, i.e., WLL may be greater than WLR or vice versa.

If option $S = 1$ is selected, the pressures entered for a wedge will be applied only to the submerged length of the wedge. The water elevations are used to calculate the submerged length of each wedge. Therefore, it is important to input the correct water elevations when using this option.

If UC is entered, S must also be entered; but if a value for UC is not entered, the uplift force on the structure is computed by the same method used for the wedges.

Water pressures on wedges - (entered only if S = 1)

Data Line 1 - Pressures on left-side wedges

- Content (2 to 10 values)
 [LN] PRESTP(1) PRESBP(1)
 [LN] PRESTP(2) PRESBP(2)
 [LN] ... PRESTP(NULAY) PRESBP(NULAY)
- Description
 PRESTP pressure at the top of a left-side wedge, ksf
 PRESBP pressure at the bottom of a left-side wedge, ksf
 NULAY number of left-side soil layers

List pressures for all the left-side wedges from the top (highest) elevation to the bottom (lowest) elevation of each wedge. Pressure is distributed linearly between the points entered. An example is shown in Figure A9.

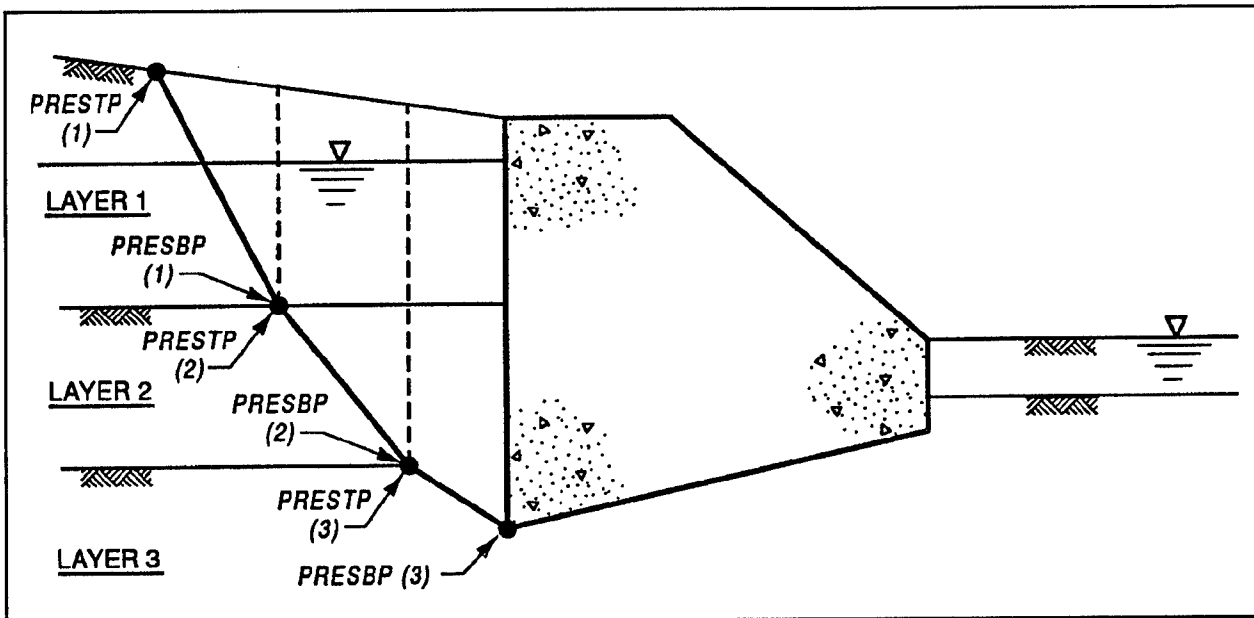

Figure A9. Input pressures on left-side wedges

Data Line 2 - Number of pressure values on structural wedge (Do not enter this line if a value for UC was entered)

- Content (one line)
 [LN] NPRST

- Description

NPRST	number of pressure values to be entered on the structural wedge
	NPRST must be between 2 and 5, inclusive

Data Line 3 - Pressures under structural wedge (not entered if a value for UC was entered)

- Content (one line, maximum five points)
[LN] XCOR(1) PRESC(1) XCOR(2) PRESC(2)
[LN] XCOR(NPRST) PRESC(NPRST)
- Description

XCOR	x-coordinates along the structural base at which a pressure
	is to be entered, ft
PRESC	pressure because of uplift on the structural base at "XCOR", ksf

Pressure is distributed linearly between the points entered, and the horizontal distance is always used to locate a pressure. The program automatically calculates the sloped distance between pressure values when the base of the structure is inclined to the horizontal. An example of how to enter the pressure values is shown in Figure A10.

Data Line 4 - Pressures under right-side wedge

- Content (2 to 20 values)
[LN] PRESTP(1) PRESBP(1)
[LN] PRESTP(2) PRESBP(2)
[LN]...PRESTP(NULAY) PRESBP(NULAY)
- Description

PRESTP	pressure at the top of a right-side wedge, ksf
PRESBP	pressure at the bottom of a right-side wedge, ksf
NULAY	number of right-side soil layers

List pressures for all the right-side wedges from the top (highest) elevation to the bottom (lowest) elevation of each wedge. Pressure is distributed linearly between entered points. An example is shown in Figure A11.

Termination of data input

- Content (one line)
[LN] "END"
- Description
"END" = keyword to end data entry

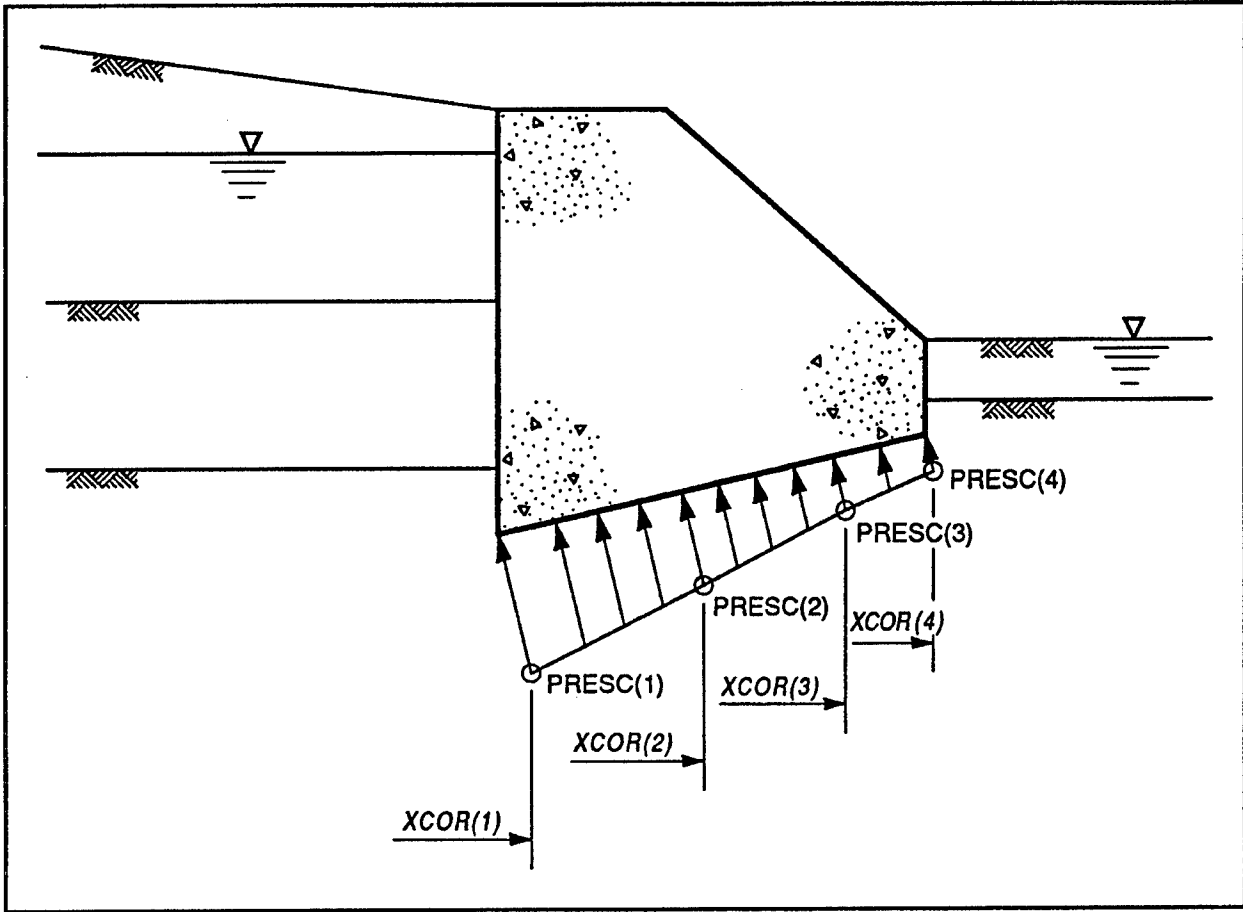

Figure A10. Input pressures on structural wedge

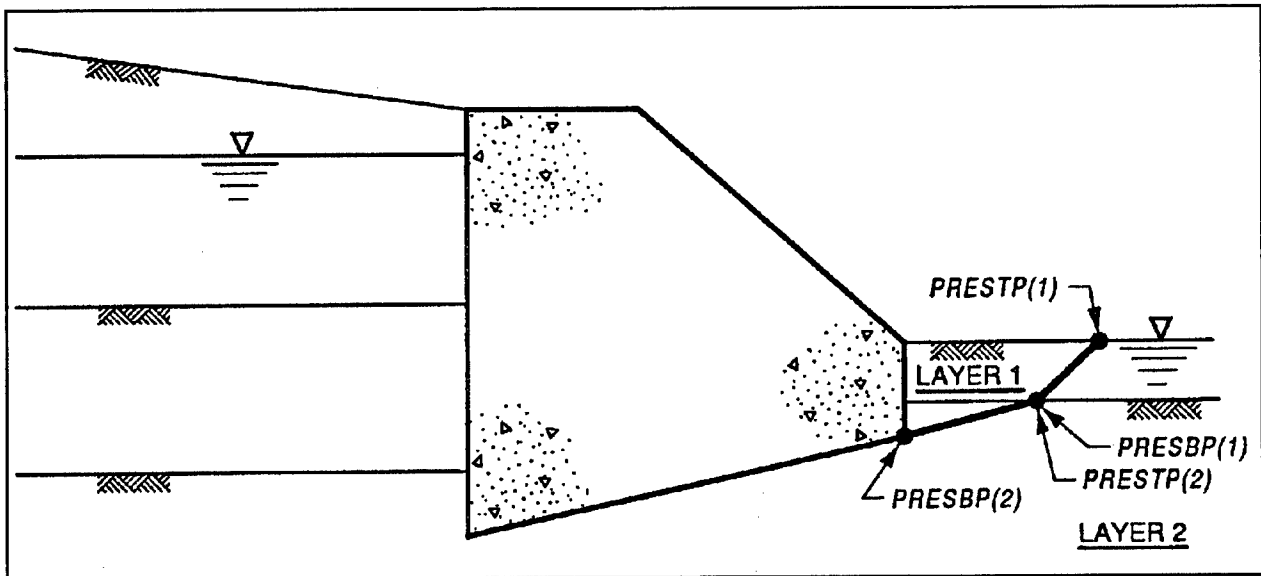

Figure A11. Input pressure on right-side wedges

Optional Data Description

An explanation of the optional data sections follows.

Wedge-angle specification

Content (one line per wedge angle specified)
[LN] "WEDG" IWEDGE FANG

Description

"WEDG" keyword for wedge angles to be specified
IWEDGE number of the wedge to have an angle specified (Figure A12 shows the numbering sequence of the wedges)
FANG failure angle (clockwise from horizontal is negative; counter-clockwise from horizontal is positive)

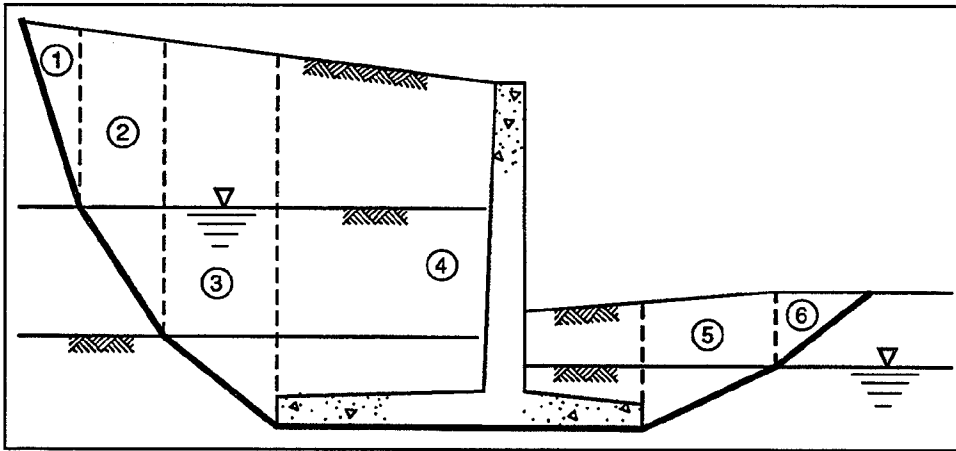

Figure A12. Numbering of wedges

Values of the input angle for left-side and right-side wedges may range from -85.0 to $+85.0$ deg, inclusive. The line defined by the rotation of the angle should not extend into the interior of the structure.

If the single-plane analysis (Method 1, Figure 15) is used for a multiple-layer problem, an angle set for any wedge (left or right) will cause all the angles on that side to be set to the input angle.

An input wedge angle must allow the plane formed by the base of the wedge to intersect the soil layer in which the wedge is contained.

When an angle is input for the structural wedge, the geometry of the structural wedge is altered. The bottom corner point of the structural wedge opposite the input angle is moved down to a new elevation at the same x-coordinate. Figure A11 illustrates how the structural wedge geometry is altered as a result of an input angle. This point is the intersection of the line defined by the input angle

with the x-coordinate boundary of the structure as shown in Figure A13. The point of rotation for the input angle is always the corner of the structure with the lowest elevation. If the base of the structure is level, the input angle is rotated about the left corner of the structure.

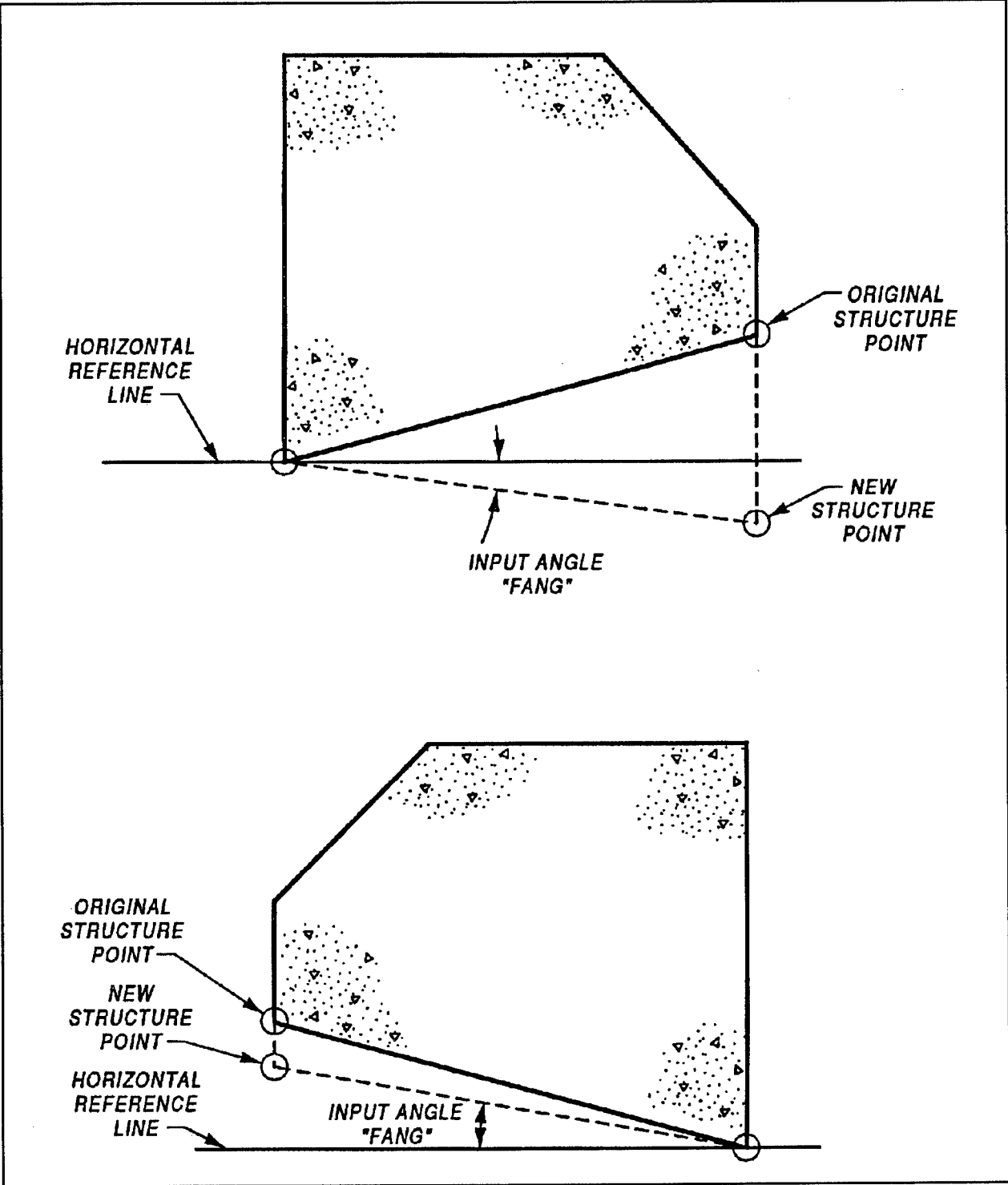

Figure A13. Structural wedge input angle

The plane defined by the input angle is the new plane of sliding. The soil beneath the structure is assumed to be an added vertical load.

The weight of the soil below the structure is calculated using the unit weight of the lowest soil layer that is opposite the side of the structure on which the input angle is applied (see Figure A13).

Earthquake conditions

Content (one line)

[LN] "EQAC" EQVT EQHO

Description

"EQAC" keyword for earthquake accelerations
EQVT vertical acceleration coefficient
EQHO horizontal acceleration coefficient

The horizontal seismic acceleration coefficient can be obtained from Table 1 of ER 1110-2-1806. If included, the vertical acceleration coefficient can be taken as two-thirds of the horizontal coefficient.

Factor of safety description

Content (one line)

[LN] "FACT" XLOW UPPER [FACTOR]

Description

"FACT" keyword for FS specifications
XLOW lower limit of the FS
UPPER upper limit of the FS
FACTOR ratio of the passive FS to the active FS (DEFAULT = 1.0)

Vertical surcharge loads

All loading conditions are initialized to zero. Each time a keyword command is used to enter a load, this load is added to those already existing. The exception to this addition is the vertical uniform load that retains only the last value entered for a particular side.

Point/line loads (maximum five loads)

Content (one line)

[LN] "VPLO" XPLO PLO

Description
 "VPLO" keyword for vertical line load
 XPLO x-coordinate of the load, ft
 PLO magnitude of the load, kips

If the load lies directly on the vertical boundary line that separates adjacent wedges, the load is included in the calculation of the wedge to the right. Figure A14 shows an example of a line load.

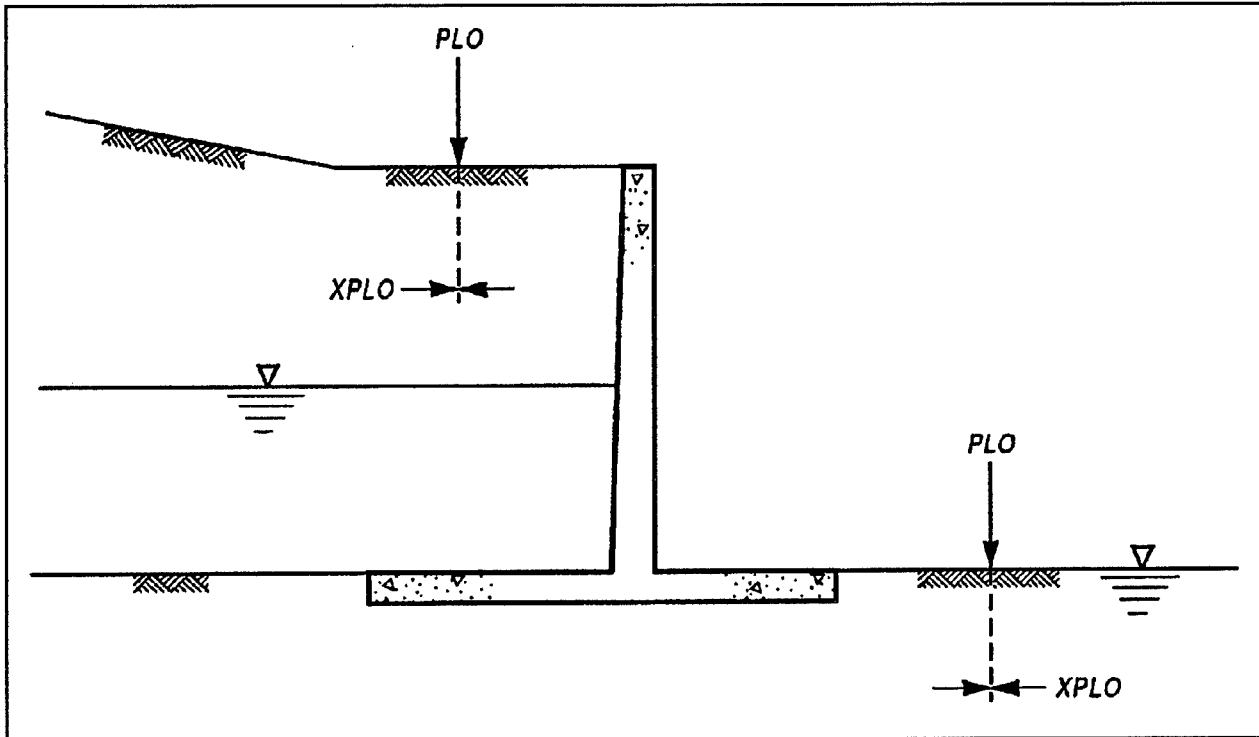

Figure A14. Point/line loads

Strip loads (Figure A15, maximum five loads)

Content (one line per load)
 [LN] "VSLO" XL WS SMAG

Description
 "VSLO" keyword for a strip load
 XL x-coordinate of the left end of the strip, ft
 WS width of the strip, ft
 SMAG magnitude of the load, k/ft

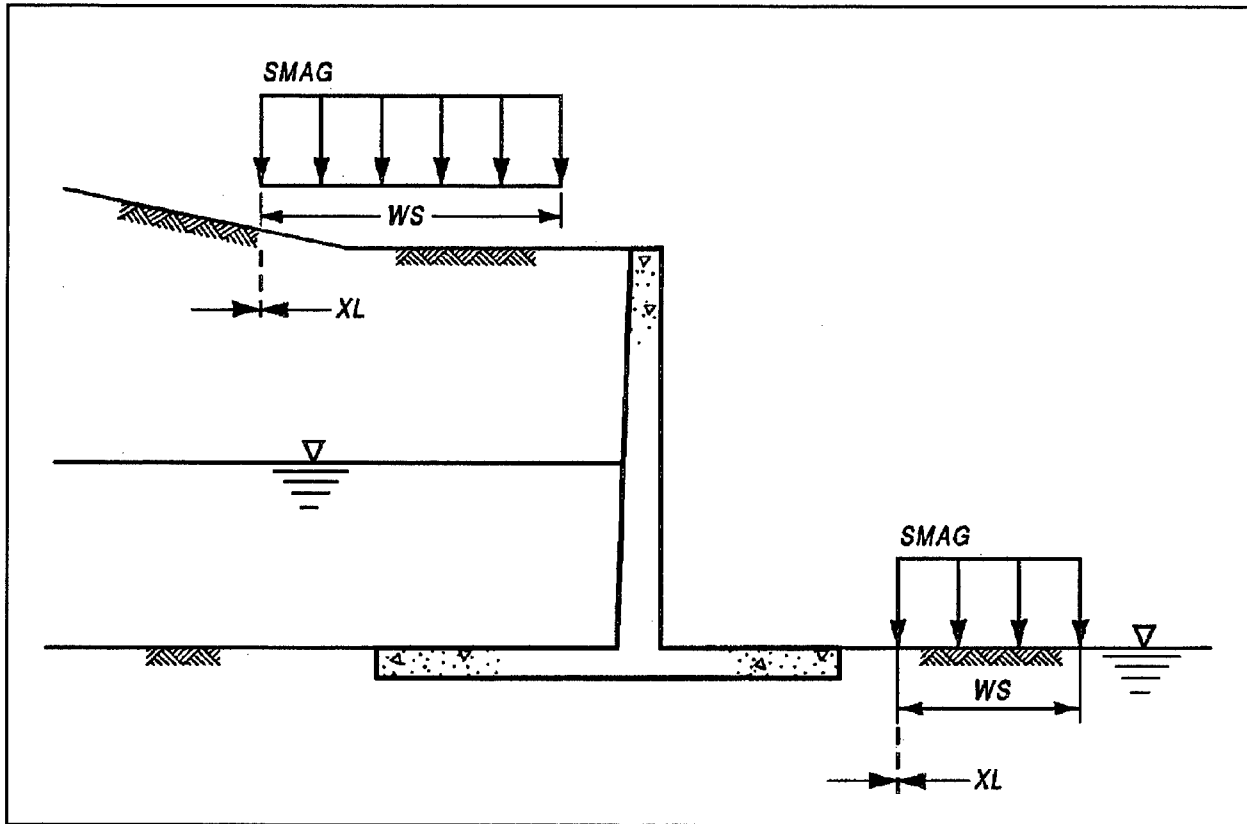

Figure A15. Strip loads

Triangular loads (Figure A16 maximum five loads)

Content (one line per load)

[LN] "VTLO" XTL WTL WDL QMAX

Description

"VTLO"	keyword for vertical triangular load
XTL	x-coordinate of the left end of the load, ft
WTL	width from left end to the maximum load, ft
WDL	width from maximum load to right end, ft
QMAX	maximum load, k/ft

Ramp loads (Figure A17 maximum five loads)

Content (one line per load)

[LN] "VRLO" XRL WR QRAM

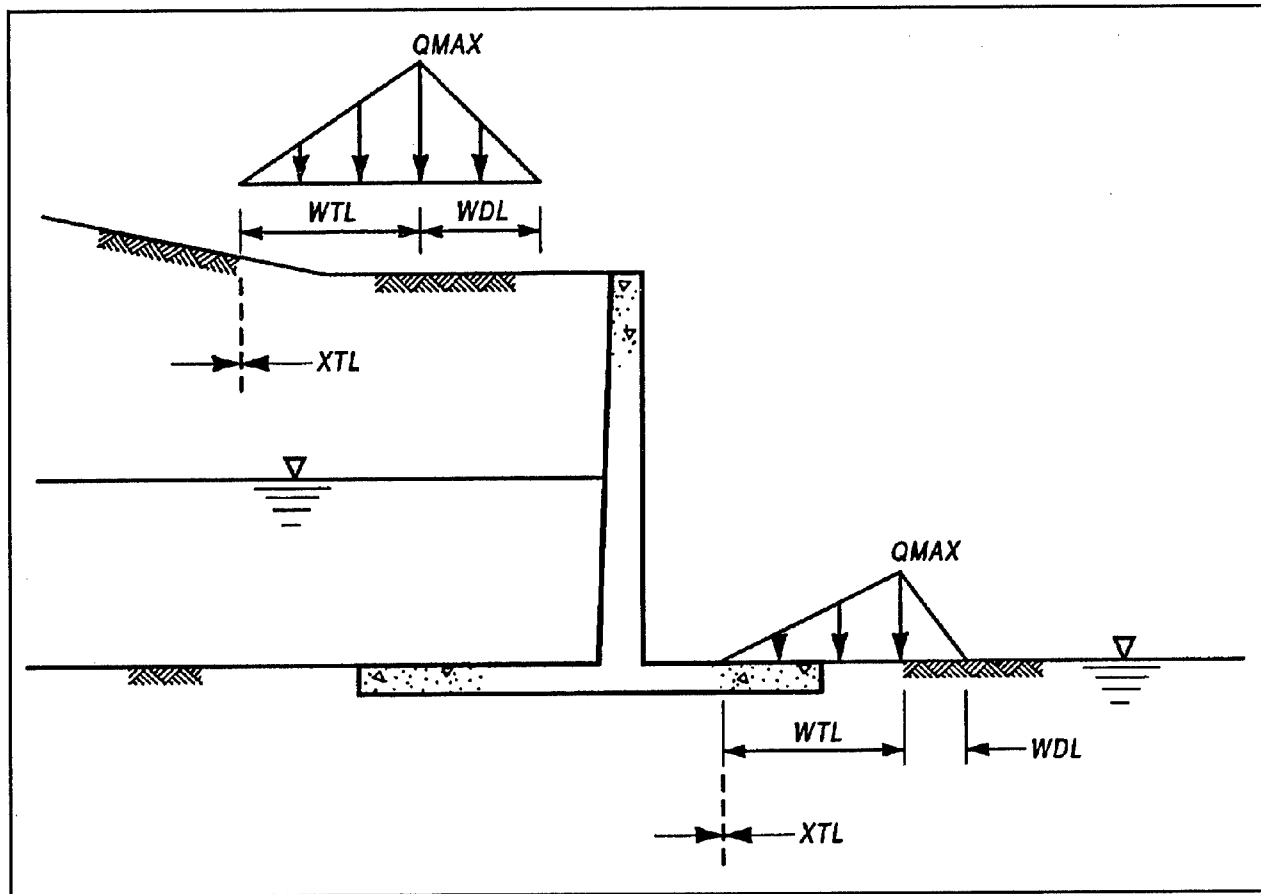

Figure A16. Triangular loads

Description

"VRLO" keyword for vertical ramp load
 XRL x-coordinate of the starting point of the ramp, ft
 WR width of the ramp (increasing load), ft
 QRAM maximum load, k/ft

Uniform loads (on either side of structure)

Content (one line per side)

[LN] "VULO" SIDE QMAG

Description

"VULO" keyword for vertical uniform load
 SIDE "L" for left side of structure
 "R" for right side of structure
 QMAG magnitude of the load, k/ft

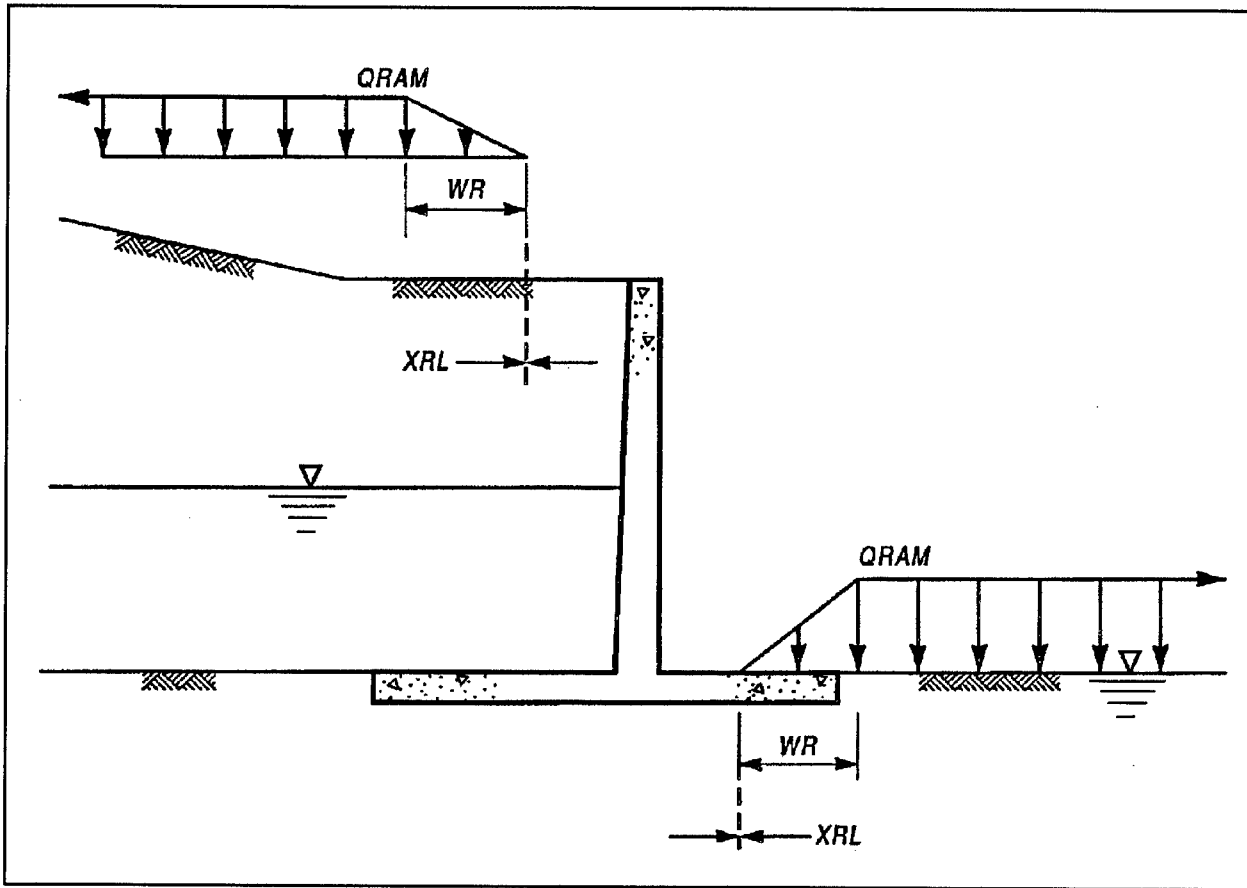

Figure A17. Ramp loads

The uniform load extends over all the soil surface (L or R) and stops where the soil meets the concrete structure. As previously stated because of the nature of uniform loads, only the last value entered for a particular side is retained.

Delete All Vertical Loads

Content (one line)

[LN] "NVLO"

Description

"NVLO" keyword to cancel all vertical surcharge loads currently in the input data and to reinitialize all these values to zero

An example of a uniform load is shown in Figure A18.

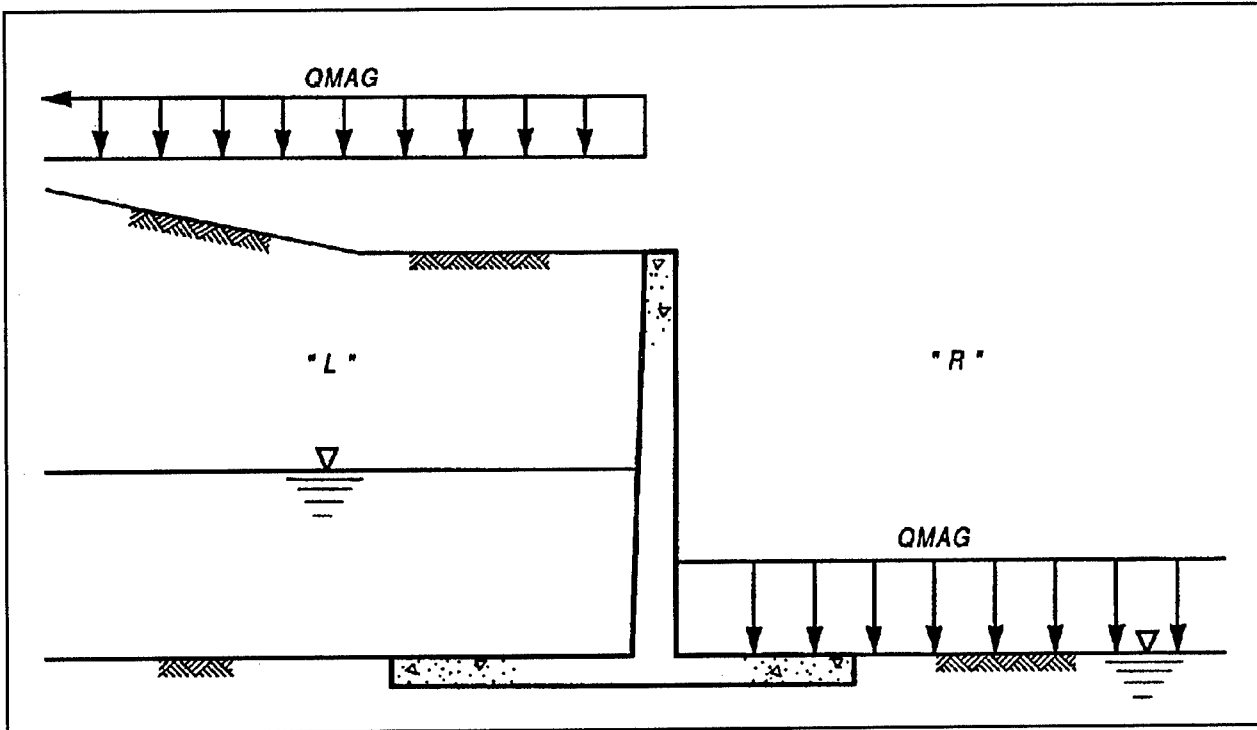

Figure A18. Uniform loads

Horizontal loads

Line load on a wedge

Content (one line per load)

[LN] "HOLO" WEDN HLOAD

Description

"HOLO"	keyword for a horizontal load
WEDN	number of the wedge on which the load is applied (refer to Figure 19)
HLOAD	magnitude of the load

The command may be repeated as often as necessary for each horizontal load on the same wedge and/or on different wedges (see Figure A19). Each time the command is used, the load is added to those existing. All loading conditions initially had a value of zero.

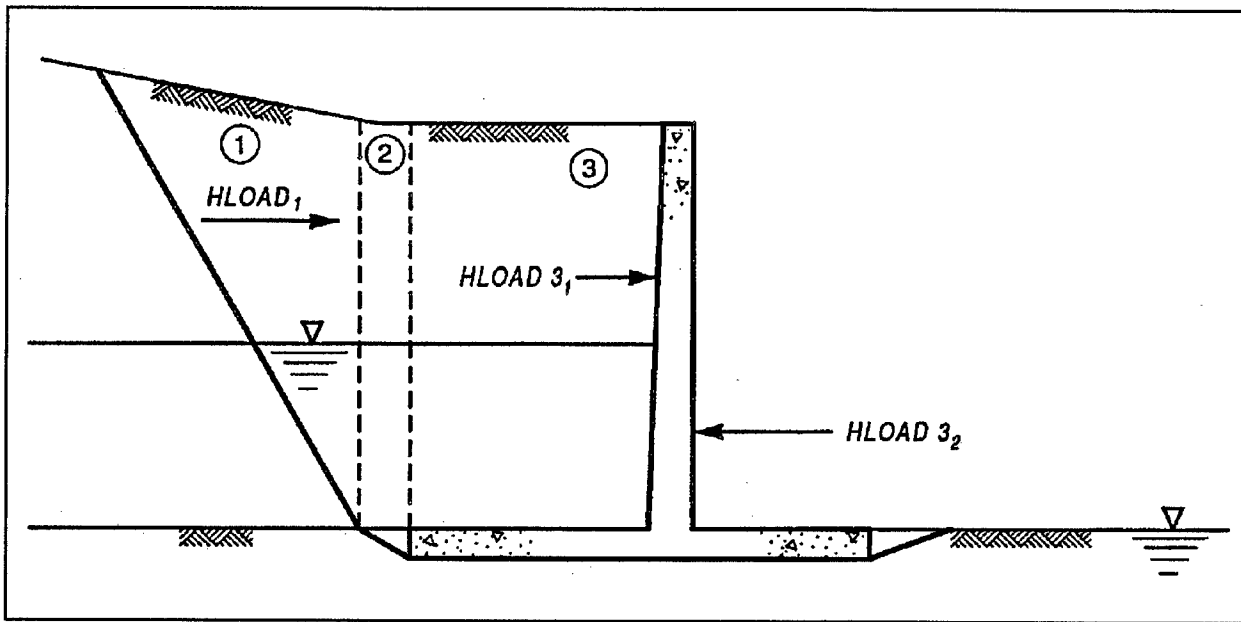

Figure A19. Horizontal loads

Delete All Horizontal Loads

Content (one line)

[LN] "NHLO"

Description

"NHLO" keyword to cancel all horizontal loads on all wedges in the current input data

Anchor Force

Content (one line)

[LN] "ANCH" ANCHF ANCHANG

Description

"ANCH" keyword for anchor force
 ANCHF anchor force, kips/ft of wall
 ANCHANG angle, deg from vertical

Data for up to three anchors within the same per foot width of wall can be input. Spacing should be accounted for in the force. This force is added to the structural wedge calculations. A positive angle is in the clockwise direction. If the anchor is not inclined, the option under a vertical load section can still be used to represent the anchor force.

Appendix B

CSLIDE Example Problems

This chapter presents several example problems to clarify input and output for the CSLIDE module of RCSLIDE:

<u>Problem</u>	<u>Description</u>	<u>Page</u>
1	Analysis of a retaining wall with surcharge loads.	B2
2	Structure with an irregular base and no passive soil wedge, including earthquake conditions.	B39
3	Control of the elevation of the active failure angle at the structure for analysis of a dam on a rock ledge. Seepage is from the passive to the active side.	B63
4	User input of precalculated seepage pressures for analysis of a dam, and an anchor force applied to the structure.	B85
5	User input of a specific factor of safety to obtain the resulting unbalanced forces.	B112
6	Use of the factor of safety ratio to reduce the passive soil force.	B124
7	Analysis of a channel-type structure.	B146

A CSLIDE data file for each example problem is included on the installation diskette. These input data files have a X0075D#.dat filename, where # represents the number and letter of the example problem. The first problem progresses through creating the input file, running the analysis, and reviewing the results. A listing of the input file and a hand verification of program solution are also included. Subsequent problems include, at a minimum, a problem description, input file listing, and output results.

Problem 1

This example illustrates the modeling of a simple retaining wall for CSLIDE analysis. The following sections will demonstrate the sequence of screen inputs used to produce the input data file and determine the factor of safety for the wall.

Part A. Find the factor of safety (FS) for the wall shown in Figure B1a.

Part B. Find the new FS after vertical surcharges have been added to both the left and right sides of the structure as shown in Figure B1b.

Problem 1A

Input file, X0075D1A.dat

```
001 TITL PROBLEM 1A - RETAINING WALL    (Title)
002 TITL
003 TITL
004 TITL
005 STRU  8  0.15  0.0  1.0             (Structural information)
006   0.00   0.00                       (Structure coordinate points)
007   0.00   2.00
008   6.00   2.00
009   6.00  14.00
010   8.00  14.00
011   8.00   2.00
012  12.00   2.00
013  12.00   0.00
014 SOLT  1  1  28  0  0.12  14       (Left-side layer description)
015 -500.00 14.00                       (Soil coordinates)
016 SORT  1  1  28  0  0.12  4       (Right-side layer
description)
017  500.00  4.00                       (Soil coordinates)
018 SOST 30.0  0.0                       (Soil below the structure)
019 METH  1                               (Analysis method)
020 WATR  5.0  1.5  0.0625  -1         (Water description)
021 END                                   (Termination)
```

CSLIDE input sequence

The four required input sections are title, structural information, and left- and right-side layer descriptions. The screen shown in Figure B2 is used to assign a problem title.

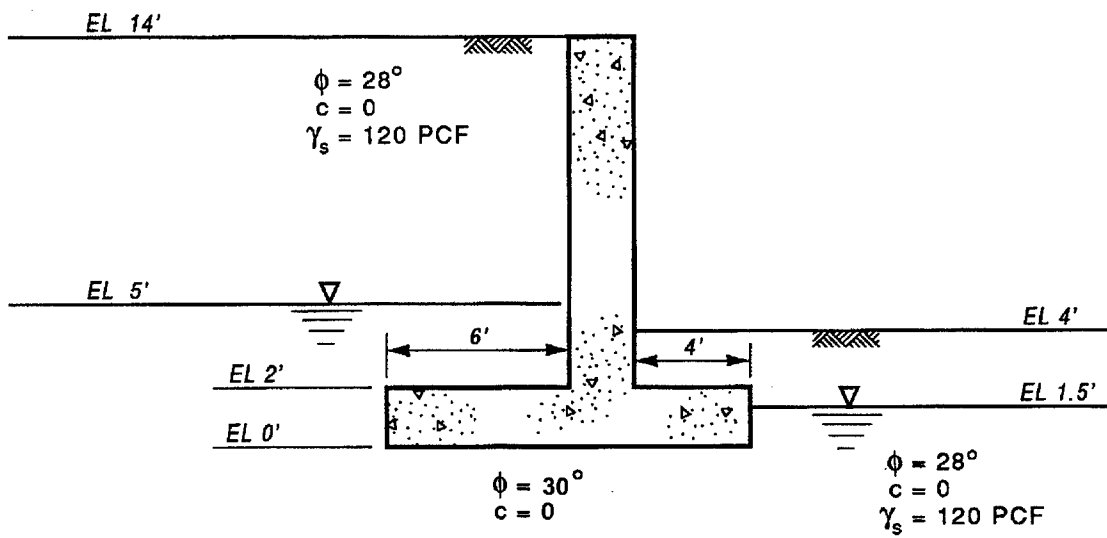

a. Soil and structure

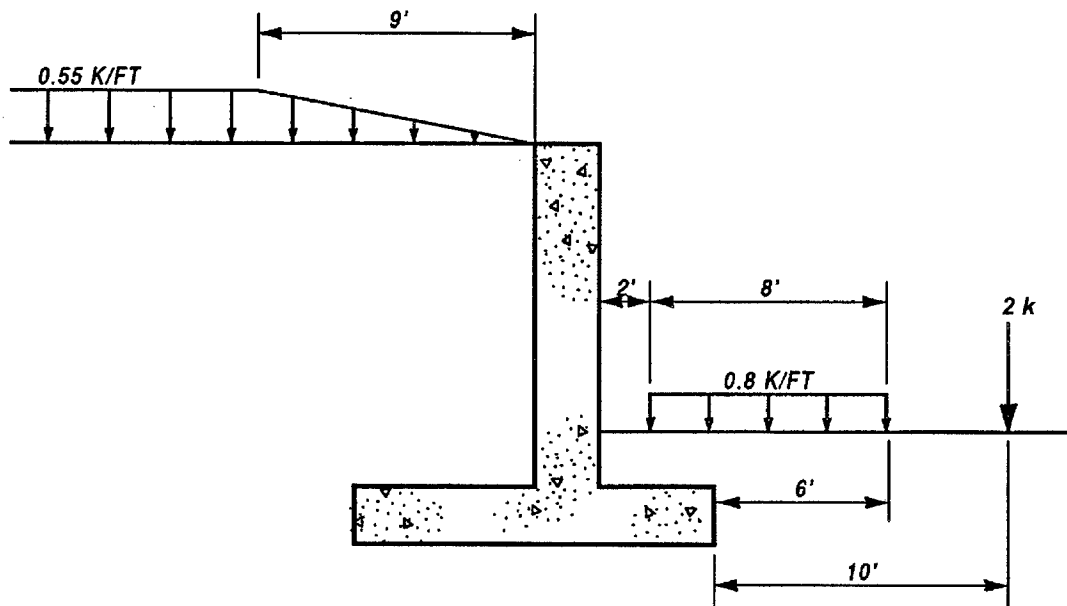

b. Vertical surcharges on wall

Figure B1. Retaining wall

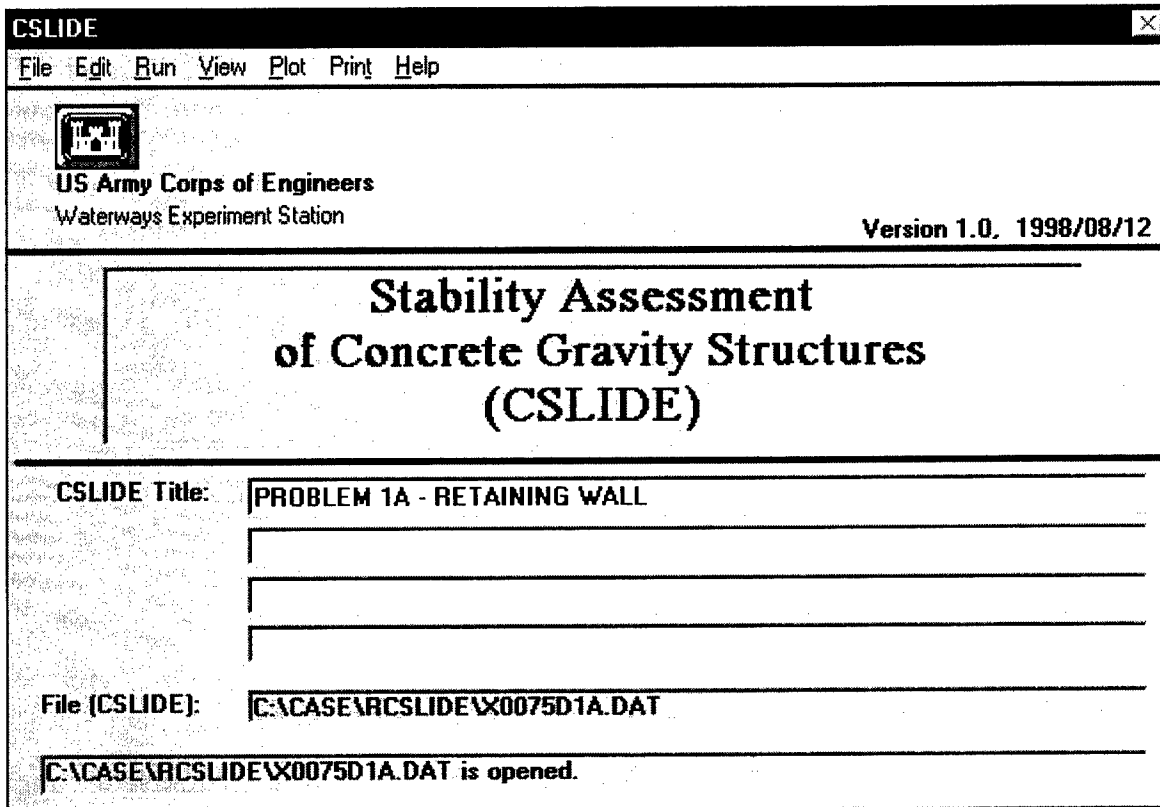

Figure B2. Title and problem description

Structural Information, **Soil Properties**, and **Soil Coordinates** windows can be selected from the **Edit** menu to enter their required values as shown in Figures B3-B7.

A description of the soil below the structure (Figure B8) is required to analyze this retaining wall. To display, select **Edit**, then **Soil Properties**, and finally **Below**.

Single-plane analysis is chosen as the method of analysis by selecting **Edit**, **Soil Properties**, and **Method** as shown in Figure B9.

Information for the water description may be entered on the screen shown in Figure B10. This screen is obtained by selecting **Edit** then **Water Description**. For this problem, seepage is computed using the line-of-creep method.

Since no safety factor values were entered, the program used the default values.

Structural Information [X]

Delete Print Help

1. Unit weight of concrete (kcf):

2. Elevation of failure angle at left side (ft):

3. Fraction of base in compression (<=1):

Point count:

[(Clockwise order from lower left corner)] 5. X-coord.:

4. Point No. (max=20): 6. Y-coord.:

Node No.	X-coord.	Y-coord.	
Node 1	0.0000	0.0000	<input type="button" value="v"/>
Node 2	0.0000	2.0000	<input type="button" value="v"/>
Node 3	6.0000	2.0000	<input type="button" value="v"/>
Node 4	6.0000	14.0000	<input type="button" value="v"/>
Node 5	8.0000	14.0000	<input type="button" value="v"/>

C:\CASE\RCSLIDE\X0075D1A.DAT is opened.

Figure B3. Structural description

Soil Property Description [X]

Print Help

Method: Side:

Total layers:

1. Layer number (max=5):

2. Total points (max=5):

3. Angle of internal friction of the layer (deg):

4. Cohesion of the layer (ksf):

5. Saturated or moist unit weight (kcf):

6. Elevation of the top of the layer (ft):

Figure B4. Soil properties (left side)

Soil Coordinate Description [X]

Print Help

[Side] Soil description: [SOLT=Left-side soil description]

Total layers: [1]

1. Layer number (max=5): [1] [v]

2. Point No. (max=5): [1] [v]

3. X-coord.: [-500.0000]

4. Y-coord.: [14.0000] Enter ->

	X-coord.	Y-coord.
Layer (1)		
Point 1	-500.0000	14.0000
Point 2		
Point 3		
Point 4		
Point 5		
Layer (2)		

Ok Cancel

Figure B5. Soil coordinates (left side)

Soil Property Description [X]

Print Help

Method: [1=Single plane] Side: [SORT=Right-side soil description]

Total layers: [1]

1. Layer number (max=5): [1] [v]

2. Total points (max=5): [1]

3. Angle of internal friction of the layer (deg): [28]

4. Cohesion of the layer (ksf): [0]

5. Saturated or moist unit weight (kcf): [0.12]

6. Elevation of the top of the layer (ft): [4]

Ok Cancel

Figure B6. Soil properties (right side)

Soil Coordinate Description [X]

Print Help

[Side] Soil description: |SORT=Right-side soil description

Total layers: |1

1. Layer number (max=5): |1

2. Point No. (max=5): |1

3. X-coord.: |500.0000

4. Y-coord.: |4.0000 [Enter ->]

	X-coord.	Y-coord.
Layer (1)		
Point 1	500.0000	4.0000
Point 2		
Point 3		
Point 4		
Point 5		
Layer (2)		

Ok [Cancel]

Figure B7. Soil coordinates (right side)

Soil Property Description [X]

Print Help

Method: |1=Single plane Side: |SOST=Soil below the structure

3. Angle of internal friction of the layer (deg): |30

4. Cohesion or Adhesion of the layer (ksf) |0

Ok [Cancel]

Figure B8. Soil properties below structure

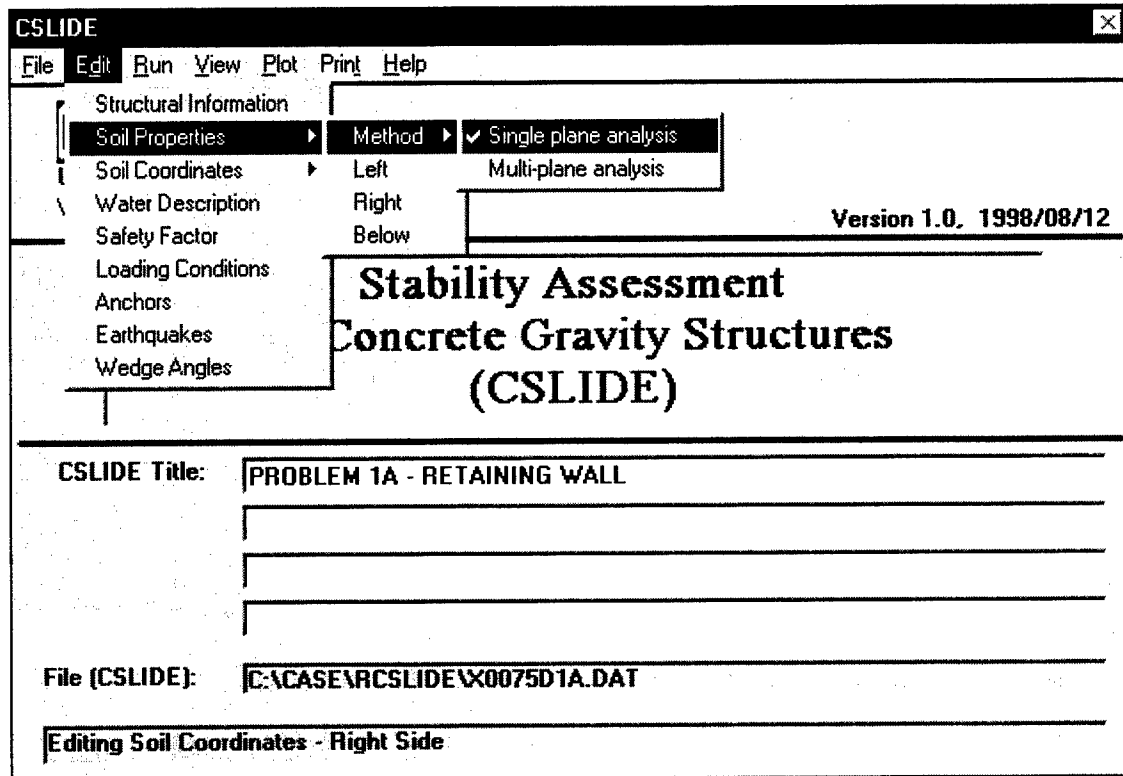

Figure B9. Select analysis method

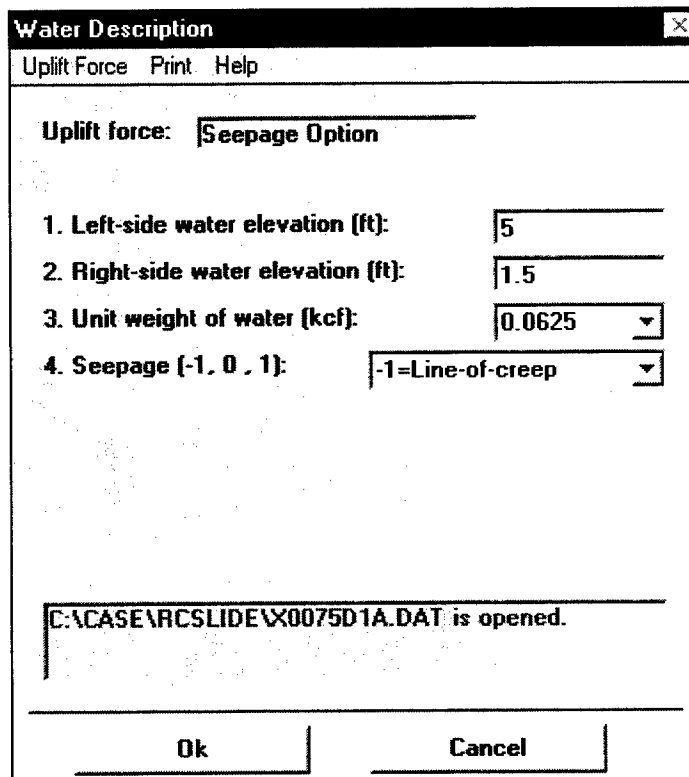

Figure B10. Water description

CSLIDE execution

To perform an analysis select the **Run** option from the main menu bar, and the following window appears (Figure B11).

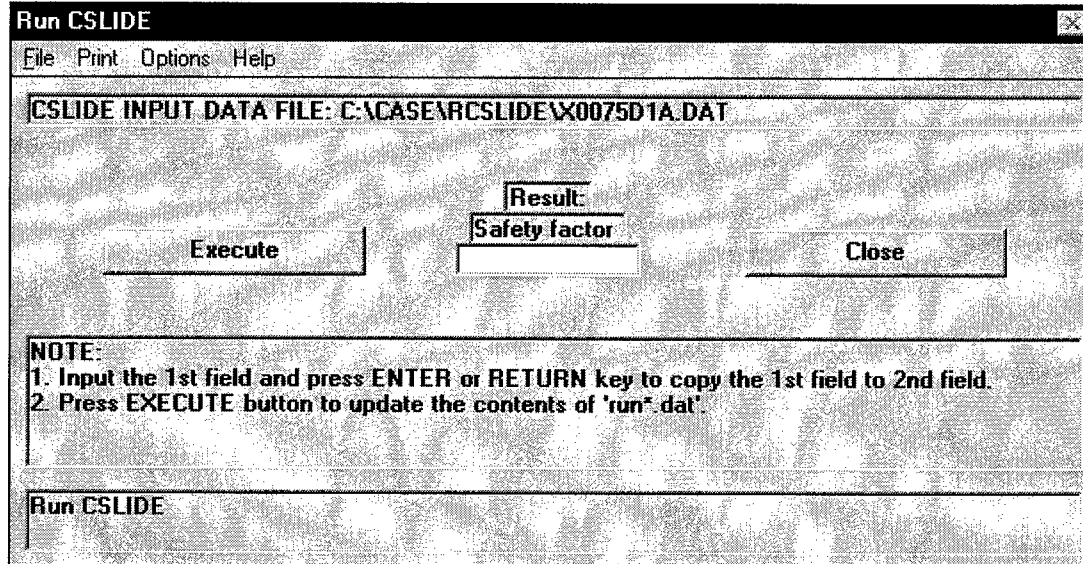

Figure B11. CSLIDE analysis window

Select **Execute** to perform analysis. The resultant factor of safety will be displayed as in Figure B12.

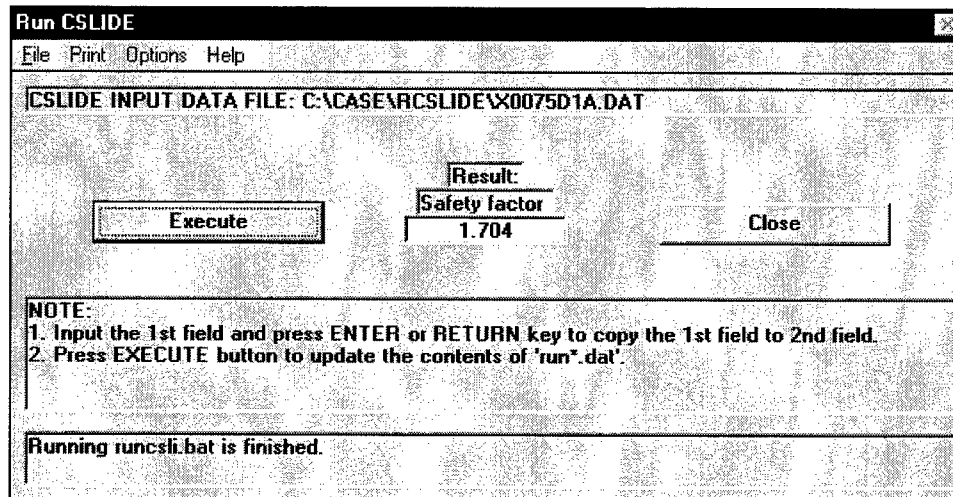

Figure B12. Resultant safety factor

CSLIDE module output

Saving Output File. Prior to viewing or using the output file, it must be saved. One method is to select **File** on the Run CSLIDE menu bar and the **Save Analysis As** on the pull-down menu (Figure B13). This will generate a Save window (Figure B14) on which a root filename may be input or the default shown will be used. By default only the output is selected to be saved.

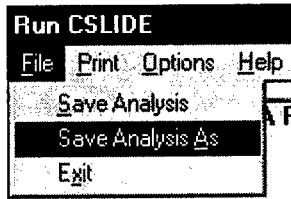

Figure B13. Save Analysis As pull-down menu

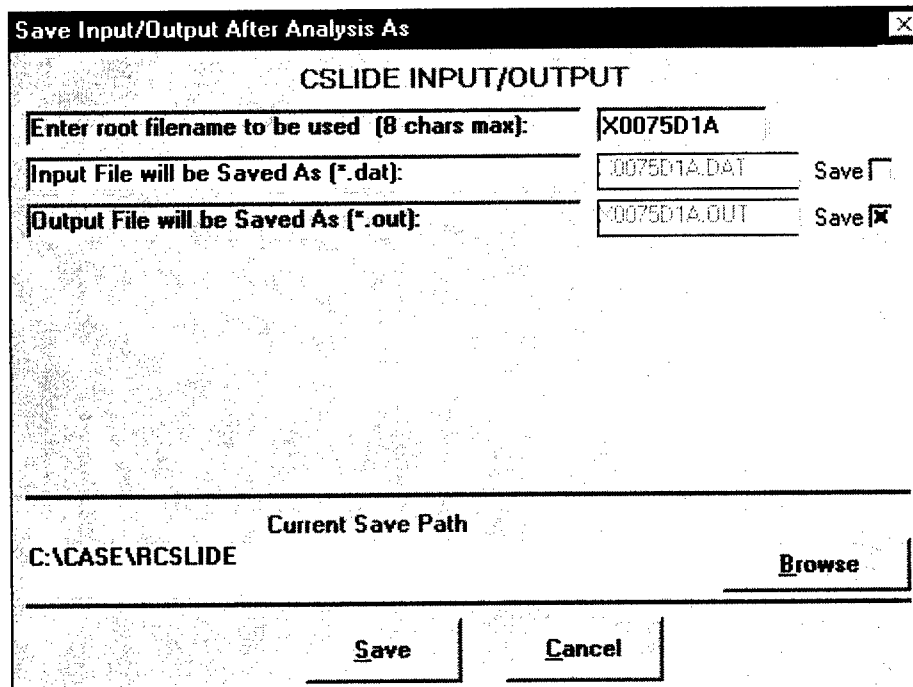

Figure B14. Save window

Review output file. To review the saved output file, select **Output** (Figure B15) from the **View** menu on the main window.

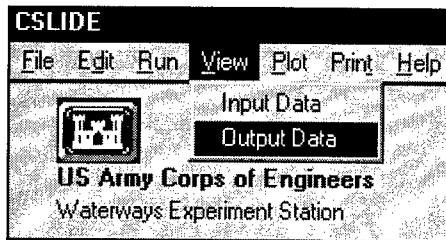

Figure B15. View menu

Enter name of output file or select an output file to review from Figure B16. Once a file to be viewed is selected, it will be displayed in a view window (Figures B17-B18). The scroll bar may be used to view the entire file.

Select **Print**, and then **File** from the **View** window to produce a hardcopy of the analysis results that follow.

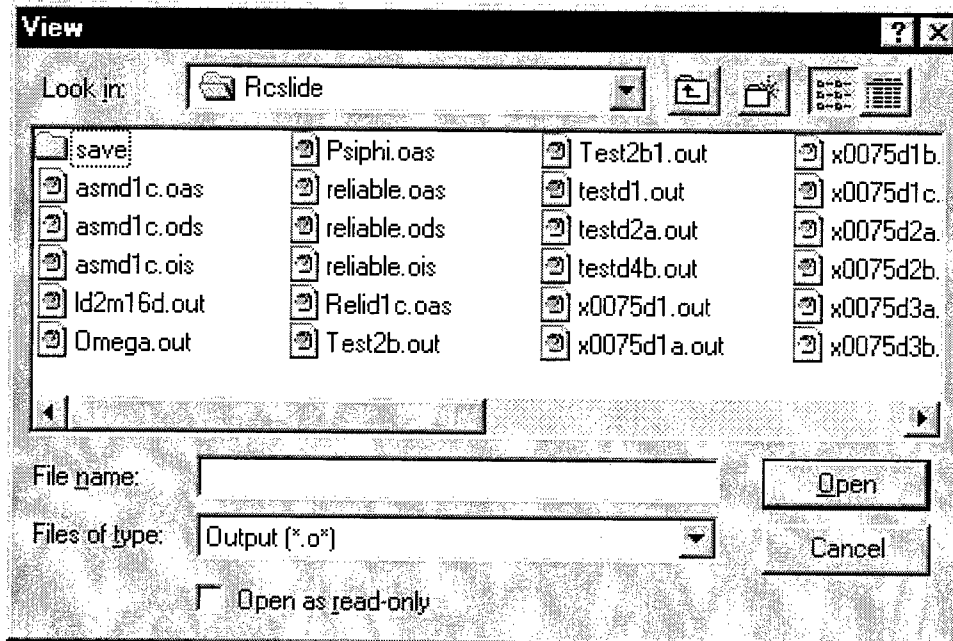

Figure B16. CSLIDE output filename

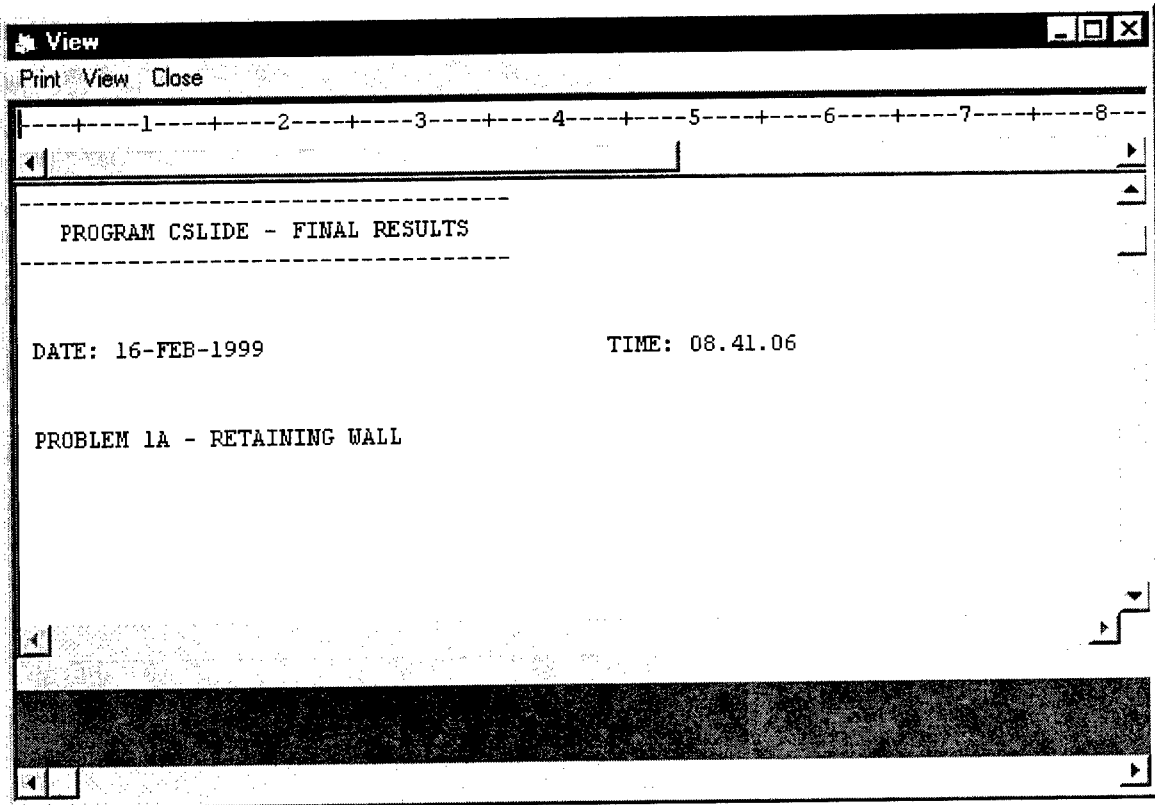

Figure B17. Review of output table

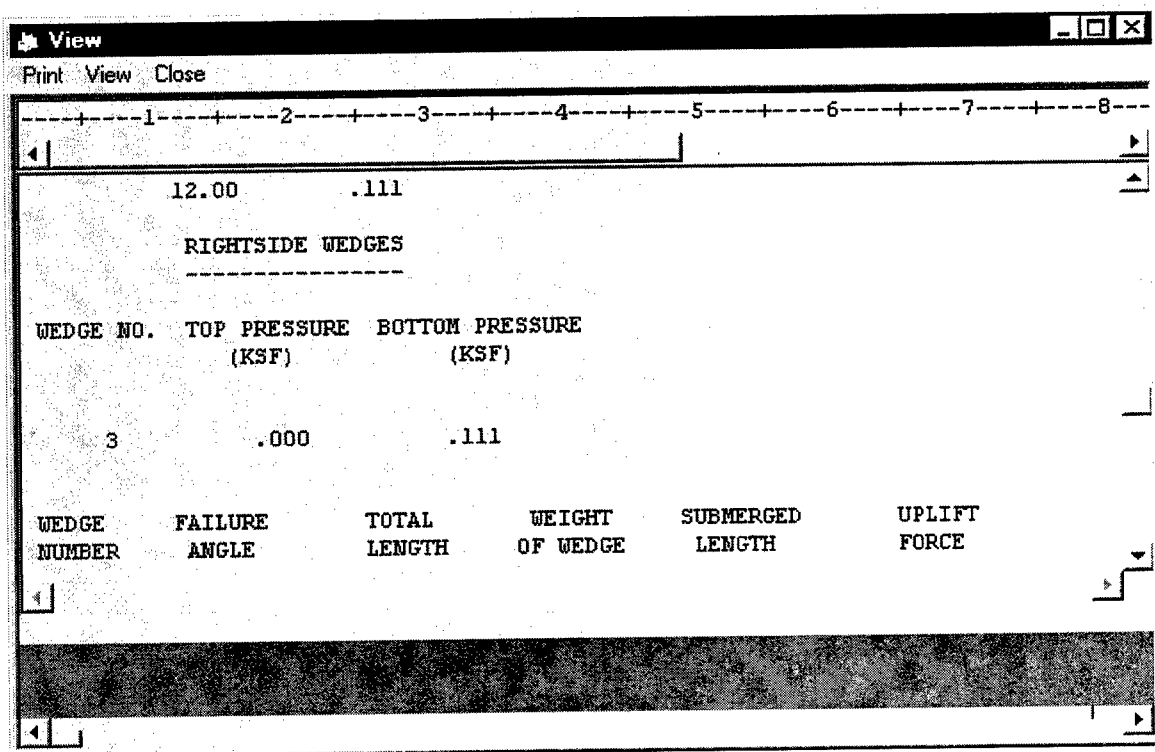

Figure B18. View of lower portion of output table

Output file, X0075D1A.out

PROGRAM CSLIDE - ECHOPRINT

DATE: 13-APR-1999

TIME: 10.14.22

PROBLEM 1A - RETAINING WALL

SINGLE FAILURE PLANE ANALYSIS

SEEPAGE FORCE BY LINE OF CREEP, GRADIENT
COMPUTED USING SHORTEST SEEPAGE PATH.

NO OF CORNERS IN STRUCTURE -----	8
DENSITY OF CONCRETE -----	.1500 (KCF)
DENSITY OF WATER -----	.0625 (KCF)
WATER LEVEL LEFT SIDE -----	5.00 (FT)
WATER LEVEL RIGHT SIDE -----	1.50 (FT)
NO. OF SOIL LAYERS LEFT SIDE -----	1
NO. OF SOIL LAYERS RIGHT SIDE -----	1

ELEV. OF WEDGE-STRUCTURE INTERSECTION ON ACTIVE SIDE OF STRUCTURE -----	.000 (FT)
--	-----------

STRUCTURE INFORMATION

POINT	X-COORD	Y-COORD
-----	-----	-----
1	.00	.00
2	.00	2.00
3	6.00	2.00
4	6.00	14.00
5	8.00	14.00
6	8.00	2.00
7	12.00	2.00
8	12.00	.00

LEFT-SIDE SOIL DATA

LAYER NO.	FRICITION ANGLE (DEG)	COHESION (KSF)	UNIT WEIGHT (KCF)	ELEV AT STRUCTURE (FT)
-----	-----	-----	-----	-----
1	28.00	.0000	.120	14.00

LAYER NO	POINT NO. 1 X-COORD	Y-COORD
1	-500.00	14.00

SOIL DATA BELOW STRUCTURE

 FRICTION ANGLE ----- 30.00
 COHESION ----- .0000

RIGHT-SIDE SOIL DATA

LAYER NO.	FRICTION ANGLE (DEG)	COHESION (KSF)	UNIT WEIGHT (KCF)	ELEV AT STRUCTURE (FT)
1	28.00	.0000	.120	4.00

LAYER NO	POINT NO. 1 X-COORD	Y-COORD
1	500.00	4.00

 PROGRAM CSLIDE - FINAL RESULTS

DATE: 13-APR-1999

TIME: 10.14.22

PROBLEM 1A - RETAINING WALL

SINGLE FAILURE PLANE ANALYSIS

SEEPAGE FORCE COMPUTED BY LINE OF CREEP

WEDGE NUMBER	HORIZONTAL LOADS		VERTICAL LOAD (KIPS)
	LEFT SIDE (KIPS)	RIGHT SIDE (KIPS)	
1	.000	.000	.000
2	.000	.000	9.600
3	.000	.000	.000

WATER PRESSURES ON WEDGES

LEFT-SIDE WEDGES

WEDGE NO.	TOP PRESSURE (KSF)	BOTTOM PRESSURE (KSF)
1	.000	.253

STRUCTURAL WEDGE

X-COORD. (FT)	PRESSURE (KSF)
.00	.253
12.00	.111

RIGHT-SIDE WEDGES

WEDGE NO.	TOP PRESSURE (KSF)	BOTTOM PRESSURE (KSF)
3	.000	.111

WEDGE NUMBER	FAILURE ANGLE (DEG)	TOTAL LENGTH (FT)	WEIGHT OF WEDGE (KIPS)	SUBMERGED LENGTH (FT)	UPLIFT FORCE (KIPS)
1	-53.669	17.378	8.648	6.207	.786
2	.000	12.000	7.200	12.000	2.189
3	36.330	6.752	1.305	2.532	.141

WEDGE
NUMBER

NET FORCE
ON WEDGE
(KIPS)

1	-6.653
2	4.950
3	1.703

SUM OF FORCES ON SYSTEM ---- .000
FACTOR OF SAFETY ----- 1.704

Plot of input and output data. A plot of the input data, Figure B19, may be obtained by selecting **Plot**, then **Structure** on the main menu. The zoom section of the plot window contains a scale factor that can be used to change the size of the selected plot.

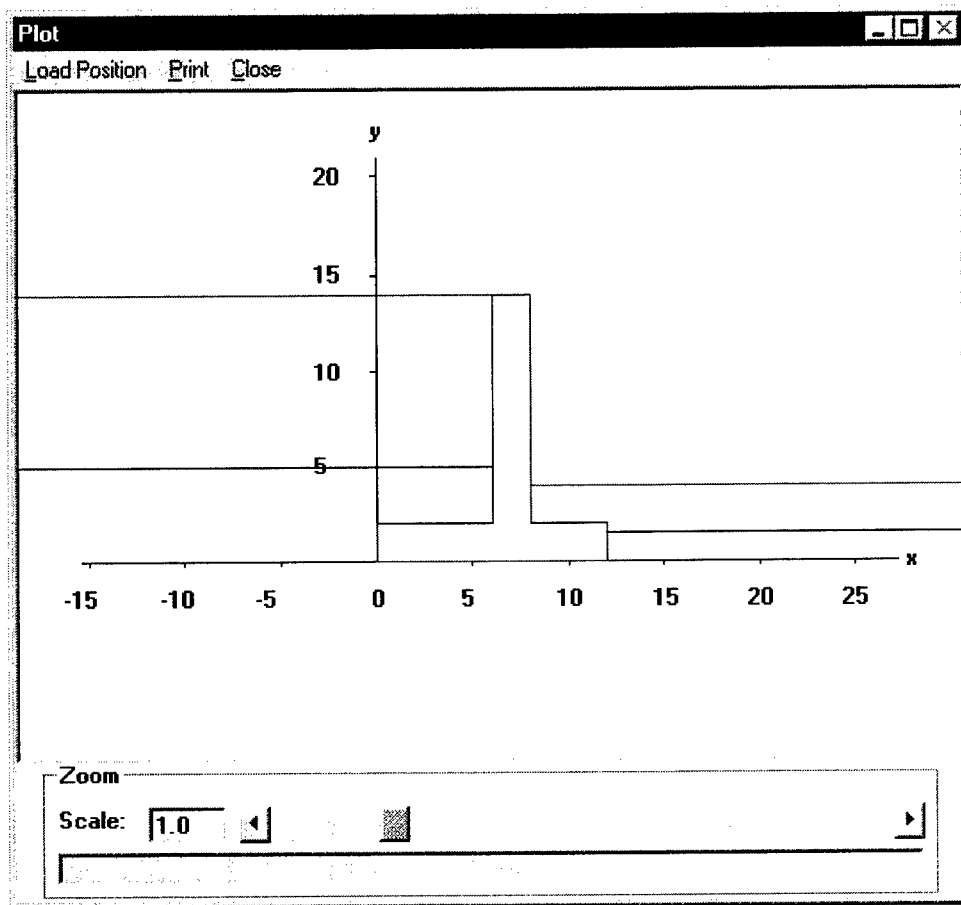

Figure B19. Plot of input structure

Failure surface plot can be displayed by selecting **Plot** then **Failure Surface** (Figure B20). Like the structure plot, the zoom section contains a scale factor to change the plot's size.

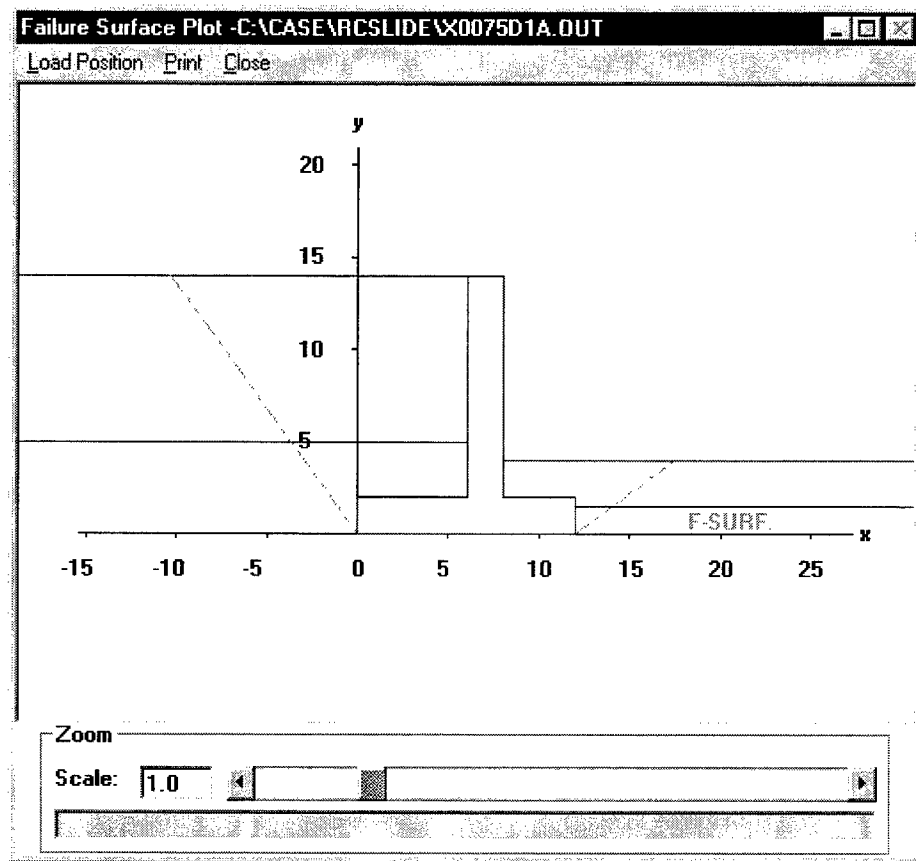

Figure B20. Failure Surface plot (Problem 1A)

To obtain wedge plots, select **Plot**, then **Wedges** on the main menu, and provide the name of the output file to plot, as shown in Figure B21. To plot wedges, provide the name of the output file for the current problem (Figure B21). Each wedge (Figures B22-B24) with its applied forces may be reviewed by selecting either **Previous** or **Next** on the menu bar.

Hand Check of CSLIDE Results for Problem 1A, No Vertical Loads

Coulomb's method for computing a failure plane angle of $\alpha = \left(45 \pm \frac{\phi_d}{2} \right)$

through a soil layer requires:

- a. The soil layer in which a wedge is formed must be a horizontal uniform layer.
- b. The soil layer must be completely saturated or completely unsaturated.
- c. If external loads or other soil layers are present, they must be uniform over the entire surface of the soil layer.

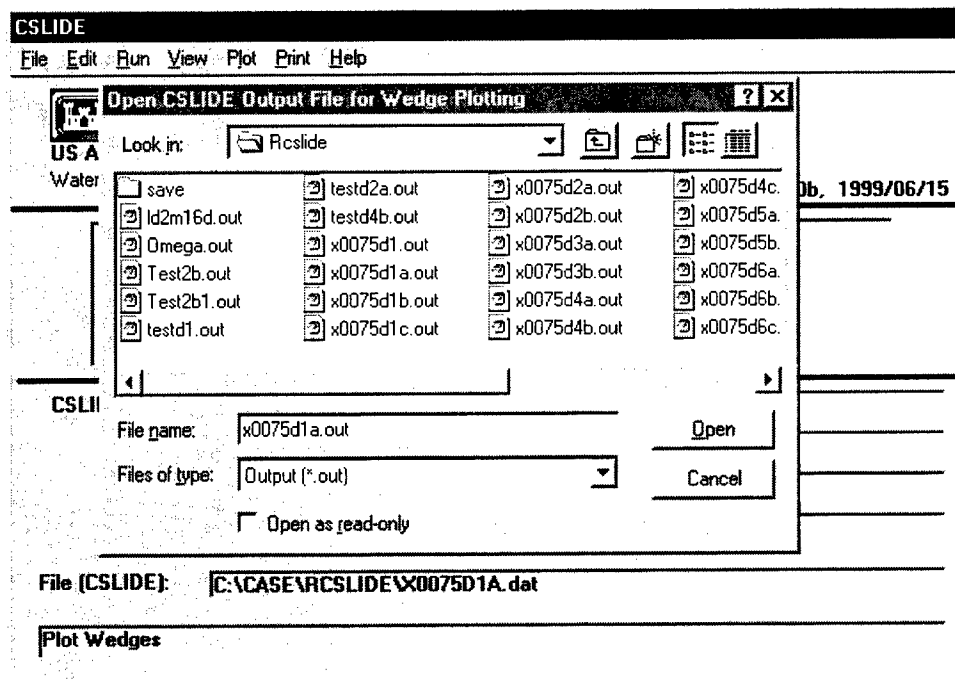

Figure B21. Open output file

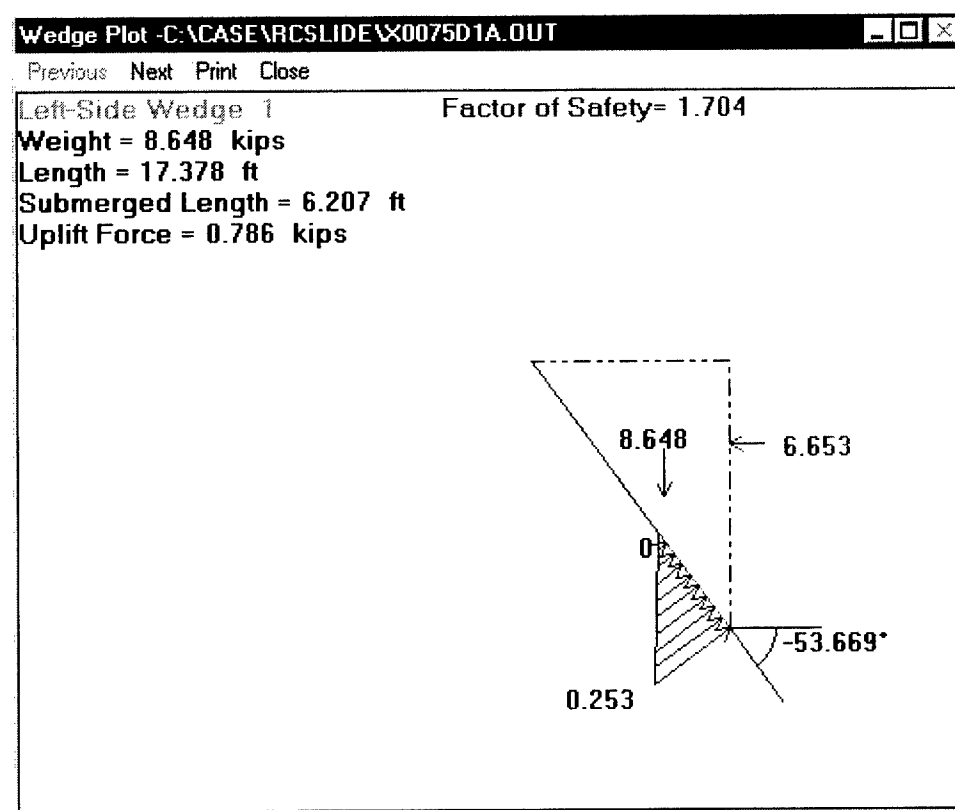

Figure B22. Plot of left-side wedge (Problem 1A)

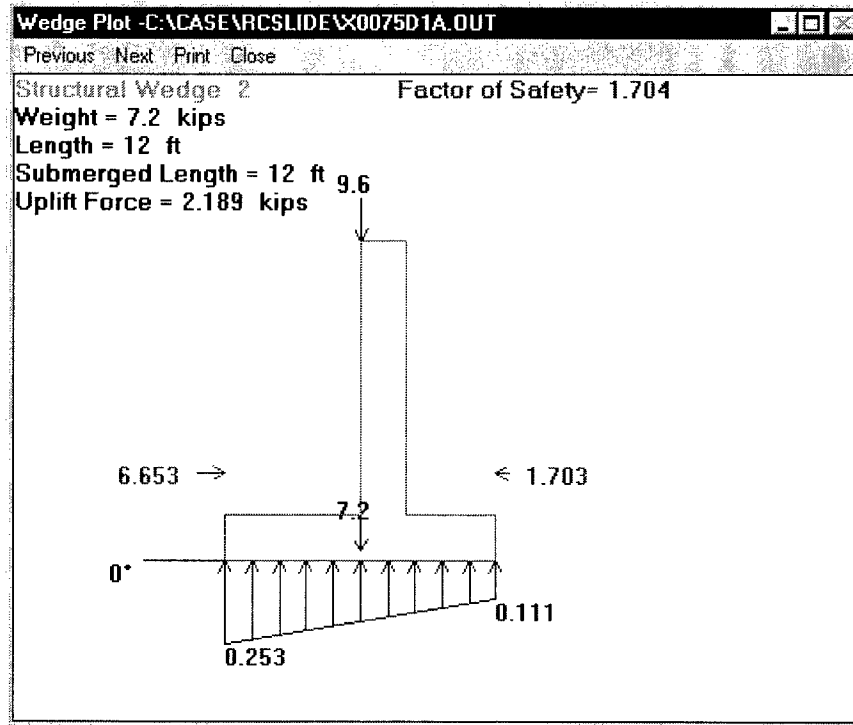

Figure B23. Plot of structural wedge (Problem 1A)

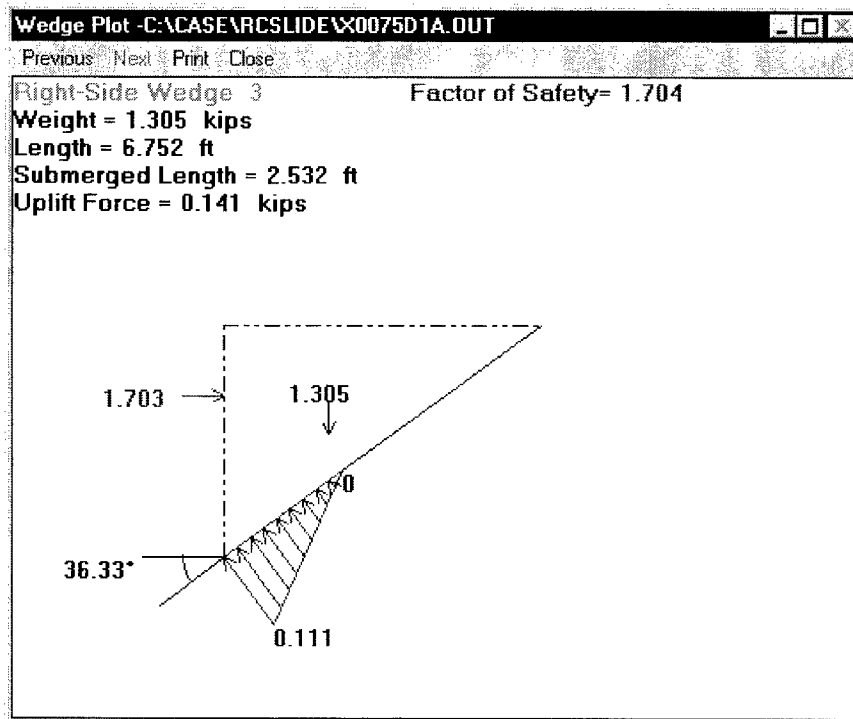

Figure B24. Plot of right-side wedge (Problem 1A)

Figure B25 shows the assumed wedge failure mechanism. It is followed by calculations of seepage pressures, by the line-of-creep method, at wedge vertex elevations. Calculation of the net force on the wedge is performed using the general wedge equation. Since the depth of the wall is one foot, all calculations are made for a unit depth of one foot and the units are expressed accordingly.

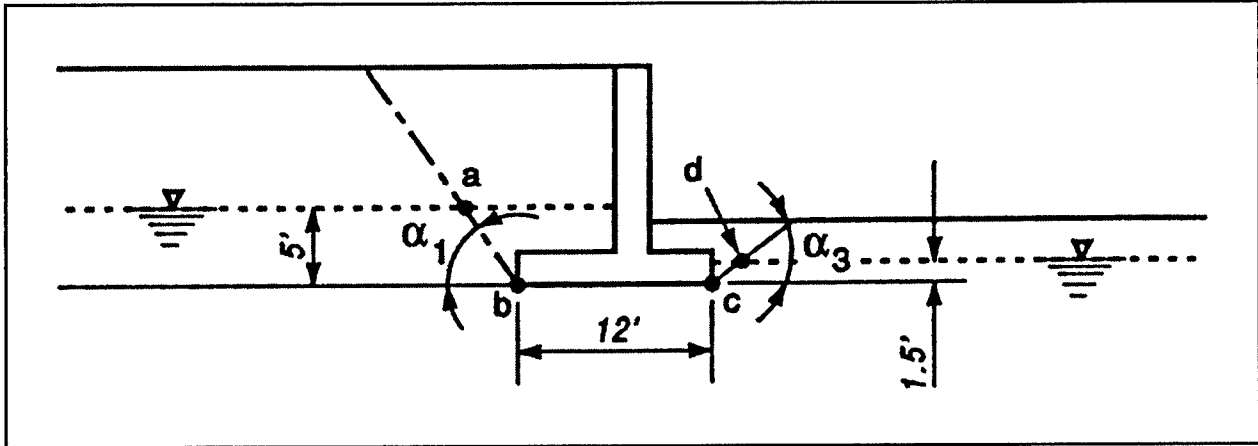

Figure B25. Retaining wall

a. Water Pressures

$$\text{Pressures: } P = \gamma_w \left[\frac{\text{Headwater Elevation} - \text{Elevation of Point of Interest}}{\text{Length of Seepage}} \right]$$

$$\text{Seepage Gradient: } i = \frac{\Delta H}{L} = \frac{(5' - 1.5')}{(5' + 12' + 1.5')} = 0.189189$$

L = Total Length of Seepage Path
= Wetted Perimeter of Structural Wedge

Length of Seepage Path = Linear distance along structural wedge from left-side water elevation to point of interest.

Wedge 1:

$$P_a = 0$$

$$P_b = \gamma_w [5' - 0' - i(5')] = 0.253 \text{ ksf}$$

Wedge 2:

$$P_b = 0.253 \text{ ksf}$$

$$P_c = \gamma_w [5' - 0' - i(5' + 12')] = 0.111 \text{ ksf}$$

Wedge 3:

$$P_c = 0.111 \text{ ksf}$$

$$P_d = 0$$

b. Angles

$$\alpha_1 = -\left(45 + \frac{\phi_d}{2}\right)$$

$$\phi_d = \tan^{-1}\left(\frac{\tan \phi_1}{FS}\right) = \tan^{-1}\left(\frac{\tan 28^\circ}{1.704}\right) = 17.33^\circ$$

$$\alpha_1 = -53.665^\circ$$

$$\alpha_2 = 0.00^\circ \quad (\alpha_2 \text{ is the inclination of structure base})$$

$$\alpha_3 = \left(45 - \frac{\phi_d}{2}\right) = 36.335^\circ$$

c. Wedge 1

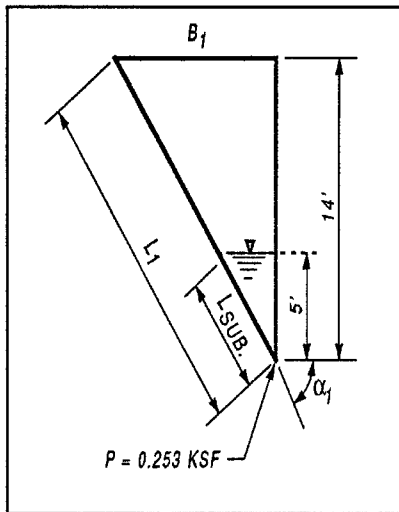

$$L_1 = \frac{14'}{\sin \alpha_1} = 17.38'$$

$$\text{Submerged length: } L_{\text{sub}} = \frac{5'}{\sin \alpha_1} = 6.21'$$

$$\text{Width: } B_1 = L_1 \cos \alpha_1 = 10.30'$$

$$\text{Weight}_1 = \frac{1}{2} (10.30') (14') (0.12 \text{ kcf}) = 8.65 \text{ k}$$

$$\text{Uplift}_1 = \frac{1}{2} (0 + 0.253) \frac{\text{k}}{\text{ft}^2} (6.21') = 0.786 \text{ k}$$

Figure B26. Wedge 1

$$\text{Net Force: } P_0 - P_1 = \frac{(8.65 \cos \alpha_1 - 0.786) \left(\frac{\tan \phi_1}{1.704}\right) + 8.65 \sin \alpha_1}{\cos \alpha_1 - \sin \alpha_1 \left(\frac{\tan \phi_1}{1.704}\right)} = -6.65 \text{ k}$$

d. Wedge 2

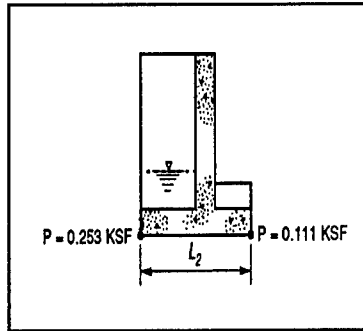

$$\text{Weight}_2 = [(2') (12') + (2') (12')] 0.150 \text{ kcf} = 7.20 \text{ k}$$

$$\text{Uplift}_2 = \frac{1}{2} (0.253 + 0.111) \frac{\text{k}}{\text{ft}^2} (12') = 2.184 \text{ k}$$

$$L_2 = L_{\text{sub}} = 12'$$

Figure B27. Wedge 2

$$\text{Vertical loads: } V_2 = \text{Soil} = [(6' \times 12') + (2' \times 4')] (0.120 \text{ kcf}) = 9.6 \text{ k}$$

$$\text{Net force: } P_1 - P_2 = \frac{[(7.2 + 9.6) \cos \alpha_2 - 2.184] \left(\frac{\tan \phi_2}{1.704} \right) + (7.2 + 9.6) \sin \alpha_2}{\cos \alpha_2 - \sin \alpha_2 \left(\frac{\tan \phi_2}{1.704} \right)} = 4.95 \text{ k}$$

e. Wedge 3

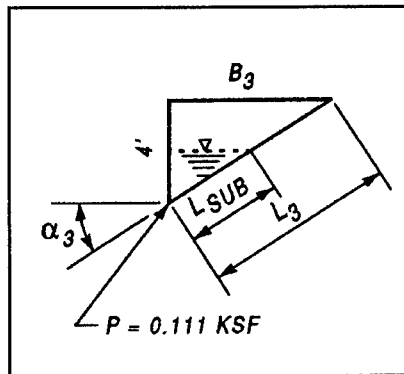

$$B_3 = \frac{4'}{\tan \alpha_3} = 5.44'$$

$$L_3 = \frac{4'}{\sin \alpha_3} = 6.75'$$

$$L_{\text{sub}} = \frac{1.5'}{\sin \alpha_3} = 2.53'$$

$$\text{Weight}_3 = \frac{1}{2} (5.44') (4') (0.120 \text{ kcf}) = 1.31 \text{ k}$$

$$\text{Uplift}_3 = \frac{1}{2} (0 + 0.111) \frac{\text{k}}{\text{ft}^2} (2.53) = 0.140 \text{ k}$$

Figure B28. Wedge 3

$$\text{Net force: } P_2 - P_3 = \frac{(1.31 \cos \alpha_3 - 0.14) \left(\frac{\tan \phi_3}{1.704} \right) + 1.31 \sin \alpha_3}{\cos \alpha_3 - \sin \alpha_3 \left(\frac{\tan \phi_3}{1.704} \right)} = 1.71 \text{ k}$$

$$\text{Sum of net forces} = -6.65 + 4.95 + 1.71 = 0.010 \text{ k}$$

Summary of Problem 1A, No Vertical Loads

Table B1								
Problem 1A CSLIDE and Hand Calculation Comparison								
Wedge No.	Horizontal Loads				Vertical Loads kips		Failure Angle deg	
	Left Side kips		Right Side kips					
	CSLIDE	Hand	CSLIDE	Hand	CSLIDE	Hand	CSLIDE	Hand
1	0.000	0.0	0.000	0.0	0.000	0.0	-53.669	-53.665
2	0.000	0.0	0.000	0.0	9.600	9.60	0.000	0.0
3	0.000	0.0	0.000	0.0	0.000	0.0	36.330	36.335
Wedge No.	Total Length ft		Weight of Wedge kips		Submerged Length ft		Uplift Force kips	
	CSLIDE	Hand	CSLIDE	Hand	CSLIDE	Hand	CSLIDE	Hand
1	17.378	17.38	8.648	8.65	6.207	6.21	0.786	0.786
2	12.000	12.00	7.200	7.20	12.000	12.00	2.189	2.184
3	6.752	6.75	1.305	1.31	2.532	2.53	0.141	0.140
Wedge No.							Net Force on Wedge kips	
							CSLIDE	Hand
1							-6.653	-6.65
2							4.950	4.95
3							1.703	1.71
Sum of Forces							0.000	0.01

Factor of Safety = 1.704

Problem 1B

Input file, X0075D1B.dat

001 TITL PROBLEM 1B - RETAINING WALL

005 STRU 8 0.15 0.0 1.0

006 0.00 0.00

007 0.00 2.00

008 6.00 2.00

009 6.00 14.00

010 8.00 14.00

011 8.00 2.00

012 12.00 2.00

013 12.00 0.00

014 SOLT 1 1 28.00 0.0 0.12 14.0

015 -500.00 14.00

```

016 SORT 1 1 28.00 0.0 0.12 4.0
017 500.00 4.00
018 SOST 30.0 0.0
019 METH 1
020 WATR 5.0 1.5 0.0625
021 FACT 0.5000 1.5000 1.0000 (Factor of safety)
022 VPLO 22.0000 2.0 (Vertical point/line load)
023 VSLO 10.0000 8.0000 0.8 (Vertical strip load)
024 VRLO 6.0000 9.0000 0.55 (Vertical ramp)
025 END

```

The default safety factor values are chosen by selecting **Safety Factor** from the **Edit** menu. Figure B29, the safety factor window, will appear containing the default values.

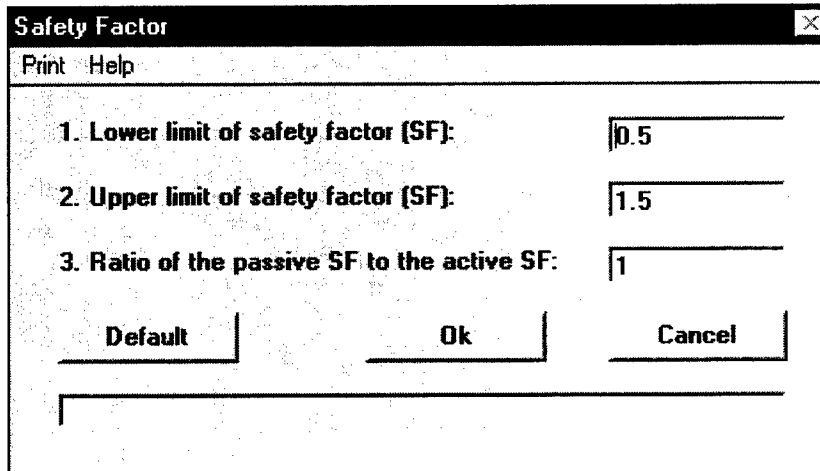

Figure B29. Safety factor window

To input vertical surcharges, select **Loading Conditions** from the **Edit** menu. A loading conditions window (Figure B30) will appear; select **Loads** on its menu bar, and choose **Vertical Surcharges** from the menu. *Point/Line Load* (Figure B30), *Strip* (Figure B31), *Ramp* (Figure 32), or other types may be chosen. Input the required values in the given window.

Loading Conditions [X]

Loads Delete Print Help

[Load] Loading condition: Vertical - Point/Line Loads

1. Load No.	2. X-position (ft)	3. Peak-position (ft)	4. End position (ft)	5a. Magnitude (ft/k)
1	22			2

Enter

1. Load No.	2. X-position (ft)	3.	4.	5a. Magnitude (k/ft)
Load 1	22			2
Load 2				
Load 3				
Load 4				
Load 5				

Ok

Figure B30. Vertical point/line load window

Loading Conditions [X]

Loads Delete Print Help

[[Load] Loading condition: Vertical - Strip Loads

1. Load No.	2. X-position (ft)	3. Width (ft)	4. End position (ft)	5a. Magnitude (ft/k)
1	10	8	0	0.8

Enter

1. Load No.	2. X-position (ft)	3. Width (ft)	4.	5a. Magnitude (k/ft)
Load 1	10	8		0.8
Load 2				
Load 3				
Load 4				
Load 5				

Ok

Figure B31. Vertical strip load window

Loading Conditions [X]

Loads Delete Print Help

[[Load] Loading condition: Vertical - Ramp Loads

1. Load No.	2. Start-position (ft)	3. Width (ft)	4. End position (ft)	5a. Magnitude (ft/k)
1	6	9	0	0.55

Enter

1. Load No.	2. Start-position (ft)	3. Width (ft)	4.	5a. Magnitude (k/ft)
Load 1	6	9		0.55
Load 2				
Load 3				
Load 4				
Load 5				

Ok

Figure B32. Vertical ramp load window

Problem output

Factor of Safety. Screen displaying the factor of safety for Problem 1B is given in Figure B33.

Run CSLIDE [X]

File Print Options Help

CSLIDE INPUT DATA FILE: C:\CASE\ARCSLIDE\X0075D1B.DAT

Execute	Result: Safety factor 1.825	Close
---------	---	-------

NOTE:

1. Input the 1st field and press ENTER or RETURN key to copy the 1st field to 2nd field.
2. Press EXECUTE button to update the contents of 'run*.dat'.

Running runcsli.bat is finished.

Figure B33. Factor of safety for Problem 1B

Output file, X0075D1B.out

PROGRAM CSLIDE - ECHOPRINT

DATE: 13-APR-1999

TIME: 10.18.09

PROBLEM 1B - RETAINING WALL

SINGLE FAILURE PLANE ANALYSIS

SEEPAGE FORCE BY LINE OF CREEP, GRADIENT
COMPUTED USING SHORTEST SEEPAGE PATH.

NO OF CORNERS IN STRUCTURE -----	8
DENSITY OF CONCRETE -----	.1500 (KCF)
DENSITY OF WATER -----	.0625 (KCF)
WATER LEVEL LEFT SIDE -----	5.00 (FT)
WATER LEVEL RIGHT SIDE -----	1.50 (FT)
NO. OF SOIL LAYERS LEFT SIDE -----	1
NO. OF SOIL LAYERS RIGHT SIDE -----	1

ELEV. OF WEDGE-STRUCTURE INTERSECTION ON ACTIVE SIDE OF STRUCTURE -----	.000 (FT)
--	-----------

STRUCTURE INFORMATION

POINT	X-COORD	Y-COORD
-----	-----	-----
1	.00	.00
2	.00	2.00
3	6.00	2.00
4	6.00	14.00
5	8.00	14.00
6	8.00	2.00
7	12.00	2.00
8	12.00	.00

LEFT-SIDE SOIL DATA

LAYER NO.	FRICTION ANGLE (DEG)	COHESION (KSF)	UNIT WEIGHT (KCF)	ELEV AT STRUCTURE (FT)
-----	-----	-----	-----	-----
1	28.00	.0000	.120	14.00

LAYER NO	POINT NO. 1 X-COORD	Y-COORD
1	-500.00	14.00

SOIL DATA BELOW STRUCTURE

FRICITION ANGLE ----- 30.00
 COHESION ----- .0000

RIGHT-SIDE SOIL DATA

LAYER NO.	FRICITION ANGLE (DEG)	COHESION (KSF)	UNIT WEIGHT (KCF)	ELEV AT STRUCTURE (FT)
1	28.00	.0000	.120	4.00

LAYER NO	POINT NO. 1 X-COORD	Y-COORD
1	500.00	4.00

VERTICAL POINT LOADS

X-COORDINATE (FT)	MAGNITUDE (KIPS)
22.00	2.000

STRIP LOADS

X-COORD OF LEFT SIDE	WIDTH	MAG. (K/F)
10.00	8.00	.8000

RAMP LOADS

X-COORD OF START	WIDTH	MAGNITUDE
6.000	9.000	.550

PROGRAM CSLIDE - FINAL RESULTS

DATE: 13-APR-1999

TIME: 10.18.09

PROBLEM 1B - RETAINING WALL

SINGLE FAILURE PLANE ANALYSIS

SEEPAGE FORCE COMPUTED BY LINE OF CREEP

WEDGE NUMBER	HORIZONTAL LOADS		VERTICAL LOAD (KIPS)
	LEFT SIDE (KIPS)	RIGHT SIDE (KIPS)	
1	.000	.000	5.705
2	.000	.000	12.300
3	.000	.000	4.800

WATER PRESSURES ON WEDGES

LEFT-SIDE WEDGES

WEDGE NO.	TOP PRESSURE (KSF)	BOTTOM PRESSURE (KSF)
1	.000	.253

STRUCTURAL WEDGE

X-COORD. (FT)	PRESSURE (KSF)
.00	.253
12.00	.111

RIGHT-SIDE WEDGES

WEDGE NO.	TOP PRESSURE (KSF)	BOTTOM PRESSURE (KSF)
-----------	-----------------------	--------------------------

3	.000	.111
---	------	------

WEDGE NUMBER	FAILURE ANGLE (DEG)	TOTAL LENGTH (FT)	WEIGHT OF WEDGE (KIPS)	SUBMERGED LENGTH (FT)	UPLIFT FORCE (KIPS)
-----------------	---------------------------	-------------------------	------------------------------	-----------------------------	---------------------------

1	-52.165	17.727	9.134	6.331	.802
2	.000	12.000	7.200	12.000	2.189
3	21.802	10.770	2.400	4.039	.225

WEDGE NUMBER	NET FORCE ON WEDGE (KIPS)
-----------------	---------------------------------

1	-11.029
2	5.475
3	5.554

SUM OF FORCES ON SYSTEM ---- .000

FACTOR OF SAFETY ----- 1.825

Structure plot (Figure B34).

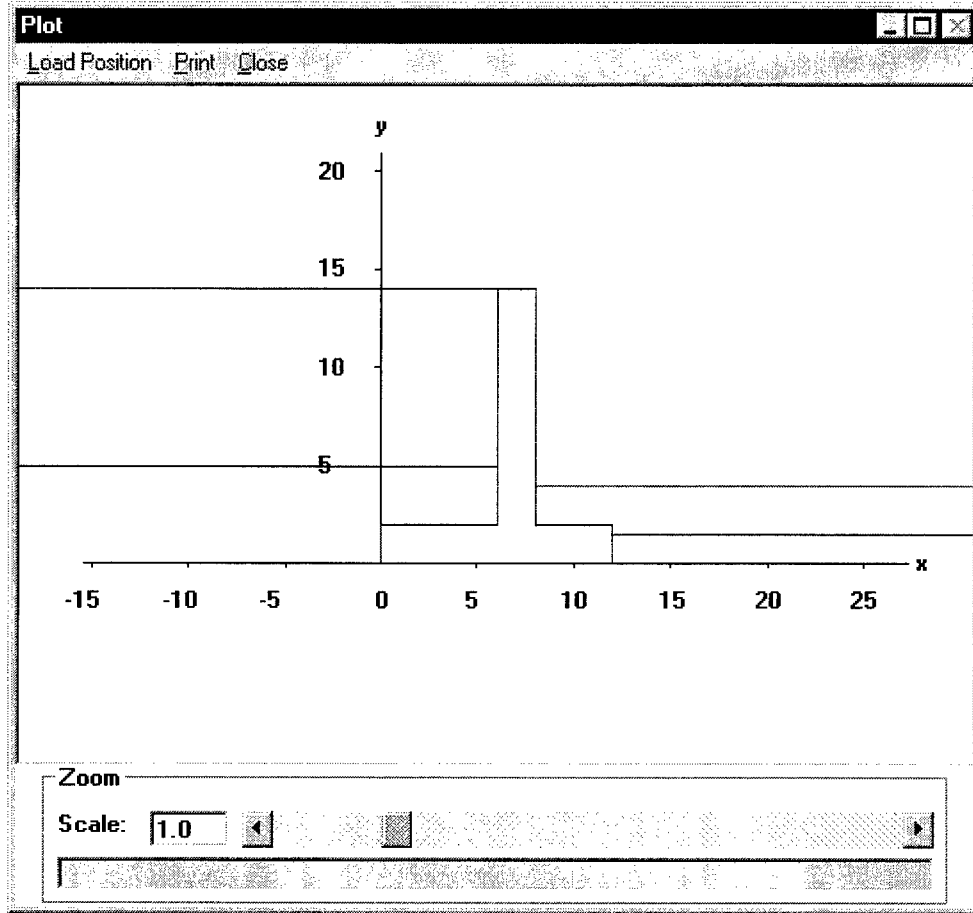

Figure B34. Structure plot

Failure Surface plot (Figure B35).

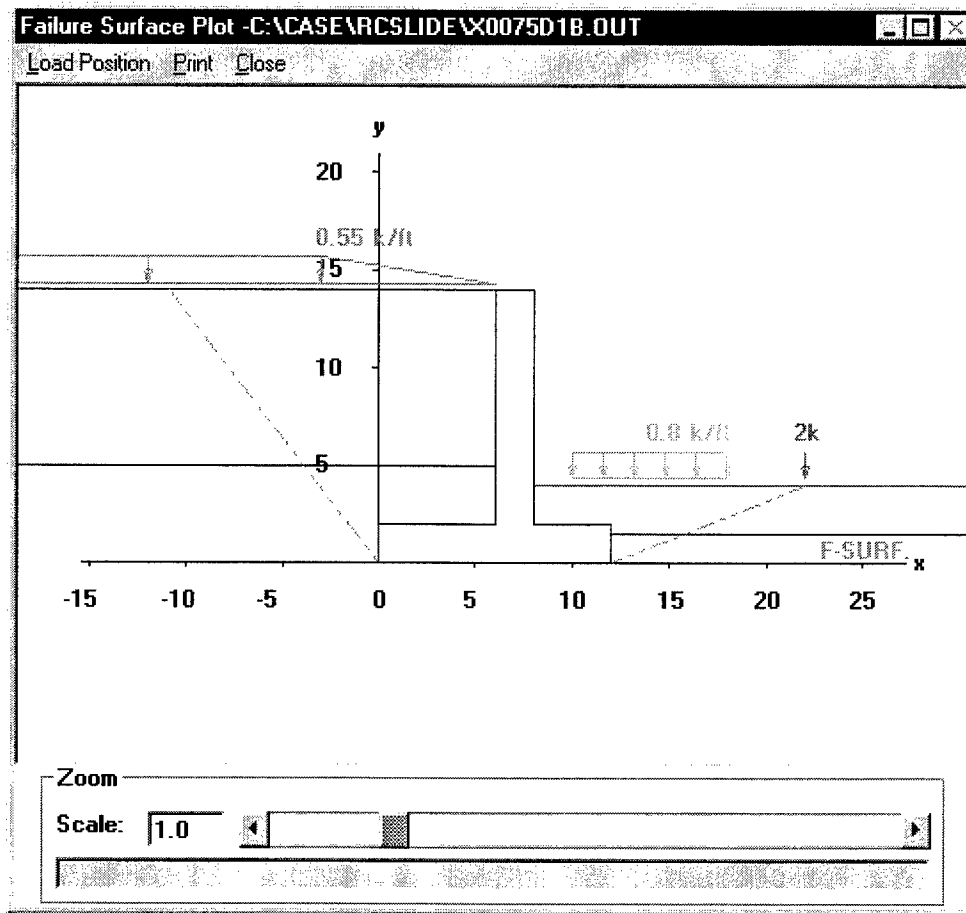

Figure B35. Failure Surface plot (Problem 1B)

Wedge plots (Figures B36-B38).

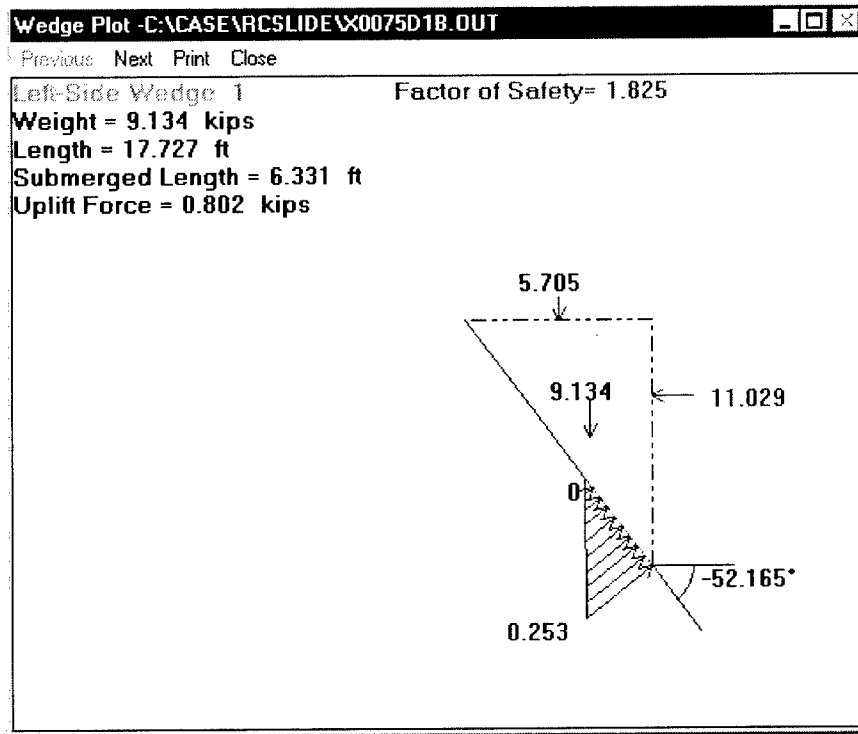

Figure B36. Left-side wedge for Problem1B

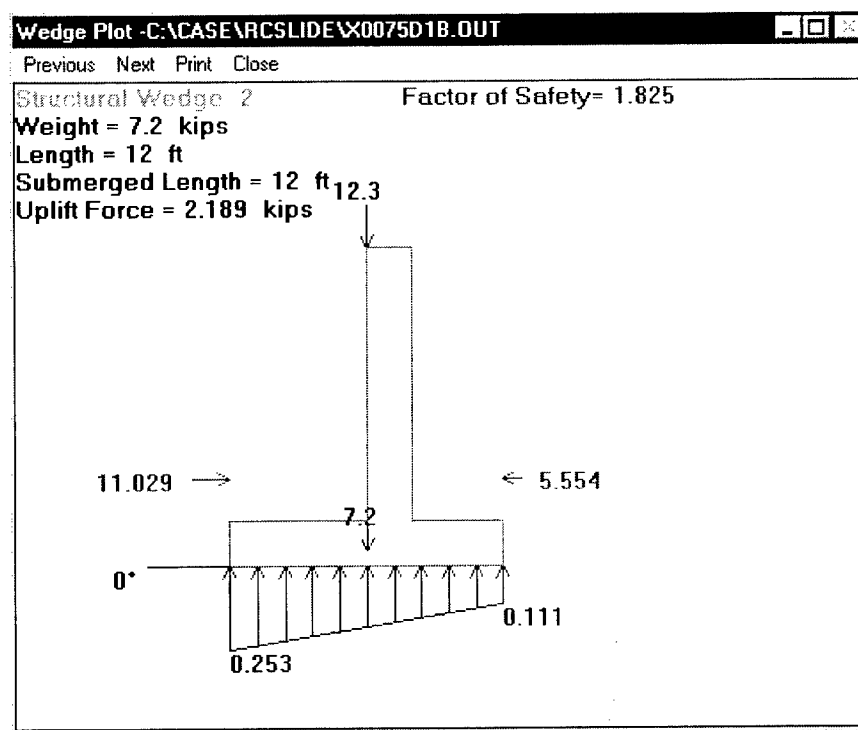

Figure B37. Structural wedge for Problem1B

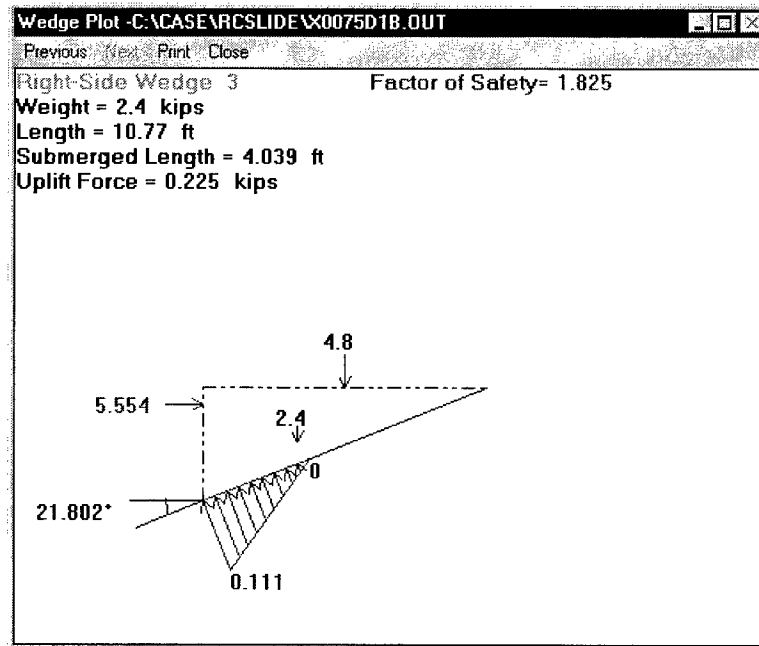

Figure B38. Right-side wedge for Problem 1B

Hand Check of CSLIDE Results Problem 1B, Vertical Loads Applied

Based upon the vertical loads as depicted in Figure B39 the following calculation can be made. Also, all calculations are made for a unit depth of one foot, and the resultant units are expressed accordingly.

a. Angles

The following equation $\left(45 \pm \frac{\phi_d}{2}\right)$ cannot be used to check these failure angles since the nonuniform surcharges over the wedge surfaces invalidate this expression. The angles calculated in CSLIDE are assumed correct, and the remaining hand checks are based upon these CSLIDE angles.

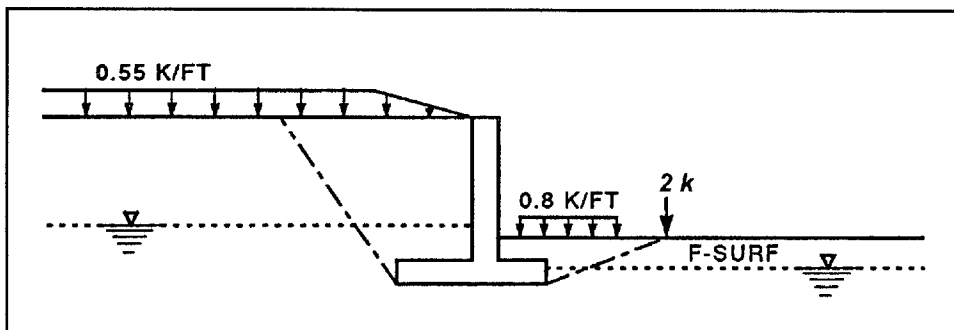

Figure B39. Retaining wall with vertical loads

b. Water Pressures

Pressures from the first analysis are:

$$P_{\text{heel}} = 0.253 \text{ ksf}$$

$$P_{\text{toe}} = 0.111 \text{ ksf}$$

c. Wedge 1

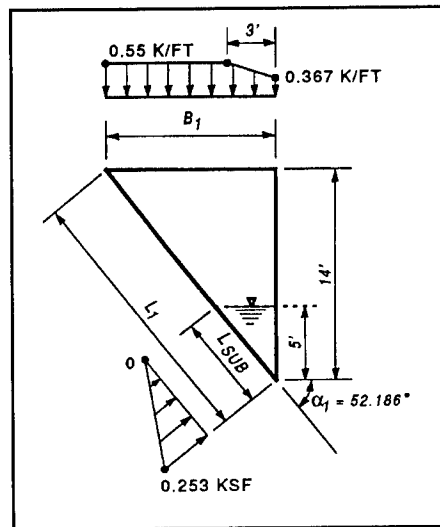

$$B_1 = \frac{14}{\tan \alpha_1} = 10.87'$$

$$L_1 = \frac{14}{\sin \alpha_1} = 17.72'$$

$$L_{\text{sub}} = \frac{5}{\sin \alpha_1} = 6.33'$$

$$\frac{\text{Total Ramp Load}}{\text{Total Ramp Length}} = \frac{(0.55 - 0) \frac{\text{k}}{\text{ft}}}{9'} = 0.0611 \frac{\text{k}}{\text{ft}}$$

Figure B40. Wedge 1

$$\text{Surcharge at Right End of Wedge 1} = 0.0611(6') = 0.367 \text{ k/ft}$$

$$\text{Vertical loads: } V_1 = 0.55 \text{ k/ft}(10.87' - 3') + \frac{1}{2} (0.55 + 0.367) \frac{\text{k}}{\text{ft}} (3') = 5.70 \text{ k}$$

$$\text{Weight}_1 = \frac{1}{2} (14')(10.87') (0.120 \text{ kcf}) = 9.13 \text{ k}$$

$$\text{Uplift}_1 = \frac{1}{2} (0 + 0.253) \frac{\text{k}}{\text{ft}^2} (6.33') = 0.801 \text{ k}$$

Net force:

$$P_0 - P_1 = \frac{[(9.13 + 5.70) \cos \alpha_1 - 0.801] \left(\frac{\tan \phi_1}{1.825} \right) + (9.13 + 5.70) \sin \alpha_1}{\cos \alpha_1 - \sin \alpha_1 \left(\frac{\tan \phi_1}{1.825} \right)} = -11.03 \text{ k}$$

d. Wedge 2

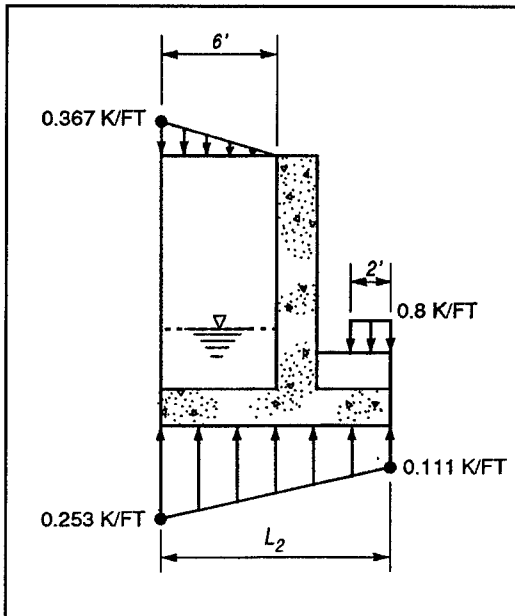

$$L_2 = L_{\text{sub}} = 12'$$

$$\text{Weight}_2 = 7.2 \text{ k} \quad \text{see firsthand calculation}$$

$$\text{Uplift}_2 = 2.184 \text{ k} \quad \text{see firsthand calculation}$$

$$V_2 = \text{soil} + \text{surcharges}$$

$$\text{soil} = 9.6 \text{ k}$$

$$\text{surcharges} = \frac{1}{2} (0.367) \frac{\text{k}}{\text{ft}} (6') + 0.8 \frac{\text{k}}{\text{ft}} (2') = 2.70 \text{ k}$$

$$V_2 = 9.6 \text{ k} + 2.70 \text{ k} = 12.30 \text{ k}$$

$$\text{Net force: } P_1 - P_2 = 5.48 \text{ k}$$

Figure B41. Wedge 2

e. Wedge 3

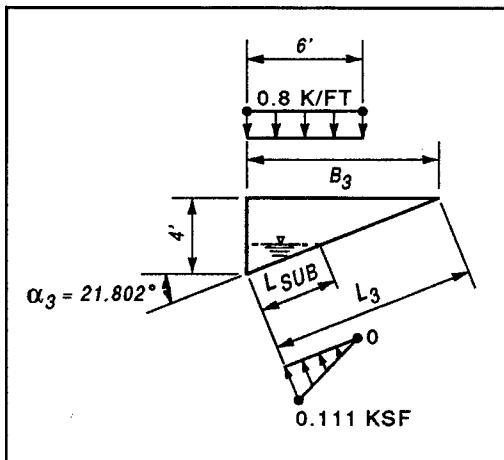

$$B_3 = \frac{4'}{\tan \alpha_3} = 10.00'$$

$$L_3 = \frac{4'}{\sin \alpha_3} = 10.77'$$

$$L_{\text{sub}} = \frac{1.5'}{\sin \alpha_3} = 4.04'$$

$$V_3 = 0.8 \text{ k/ft} (6') = 4.08 \text{ k}$$

$$W_3 = \frac{1}{2} (4') (10') (0.120 \text{ kcf}) = 2.40 \text{ k}$$

$$U_3 = \frac{1}{2} (0.111) \frac{\text{k}}{\text{ft}^2} (4.04') = 0.224 \text{ k}$$

$$\text{Net force: } P_2 - P_3 = 5.55 \text{ k}$$

Figure B42. Wedge 3

The sum of net forces is:

$$\sum (P_{i-1} - P_i) = -11.03 \text{ k} + 5.48 \text{ k} + 5.55 \text{ k} = 0.00 \text{ k}$$

The point load is not included in the surcharges since it lies just outside the passive wedge. CSLIDE chooses the angle producing a minimum passive force. To include the 2-kip load would only increase the passive resistance and produce a higher factor of safety. The critical condition is the failure mechanism with the lowest factor of safety.

Summary of Problem 1B, Retaining Wall with Vertical Surcharges

Table B2 Problem 1B CSLIDE and Hand Calculation Comparison								
Wedge No.	Horizontal Loads				Vertical Loads kips		Failure Angle deg	
	Left Side kips		Right Side kips		CSLIDE	Hand	CSLIDE	Hand
	CSLIDE	Hand	CSLIDE	Hand				
1	0.000	0.0	0.000	0.0	5.705	5.70	-52.165	-52.186
2	0.000	0.0	0.000	0.0	12.300	12.30	0.000	0.0
3	0.000	0.0	0.000	0.0	4.800	4.80	21.802	21.802
Wedge No.	Total Length ft		Weight of Wedge kips		Submerged Length ft		Uplift Force kips	
	CSLIDE	Hand	CSLIDE	Hand	CSLIDE	Hand	CSLIDE	Hand
1	17.727	17.38	9.134	9.13	6.331	6.33	0.802	0.801
2	12.000	12.00	7.200	7.20	12.000	12.00	2.189	2.184
3	10.770	10.77	2.400	2.40	4.039	4.04	0.225	0.224
Wedge No.	Net Force on Wedge kips							
							CSLIDE	Hand
1							-11.029	-11.03
2							5.475	5.48
3							5.554	5.55
Sum of Forces							0.000	0.00

Factor of Safety = 1.825

Comments on Results, Problem 1, Parts A and B

The safety factor for the system with loads is greater than the safety factor for the system without loads. In the loaded system, the passive force of Wedge 3 is more than double the passive force in the unloaded system. The active force of the loaded Wedge 1 increases by only 66 percent over the active force in the unloaded case. This accounts for the larger safety factor for the system loads.

Problem 2

This example problem shows some CSLIDE capabilities and limitations in modeling various soil and structure configurations. The structure in this problem is a gravity dam with an irregular base shown in Figure B43. In CSLIDE, the structure's base must be represented by only one plane of sliding. The structure model for CSLIDE is shown in Figure B43b. The left-side soil surface slopes down and away from the structure. The right-side soil surface lies at the base of the structure; therefore, no passive wedge exists.

Part A. Using the model shown in Figure B43b, Part A calculates the factor of safety against sliding of the dam shown in Figure B43a.

Part B. The second analysis in this example demonstrates how to use earthquake acceleration coefficients and interpret the results. It also shows how to input a specific failure plane and interpret the results. Assume that the failure mechanism for seismic conditions is the one shown in Figure B43c. Horizontal and vertical earthquake acceleration coefficients for the dam's location are 0.07 and 0.02, respectively. Calculate the factor of safety against seismic conditions.

Problem 2A

Although no right-side wedge will be formed in the first analysis, right-side soil data are required for in the input.

Input file, X0075D2A.dat

100 TITL CSLIDE DAM -- PROBLEM 2	(Title)
110 STRU 6 .15 4.00 1.00	(Structural information)
120 0 40 0 72 15 72 25 60 80 60 80 48	(Structure coordinates)
130 SOLT 1 2 32 0 .125 60	(Left-side soil description)
140 -400 38 -50 38	(Soil coordinate points)
150 SOST 30 .05	(Soil below the structure)
160 SORT 1 1 30 .05 .122 48	(Right-side soil description)
170 400 48	(Soil coordinate points)
180 METH 1	(Analysis method)
190 VPLO 5 60	(Vertical point/line load)
200 WATR 70 53 .0625 -1	(Water description)
210 END	

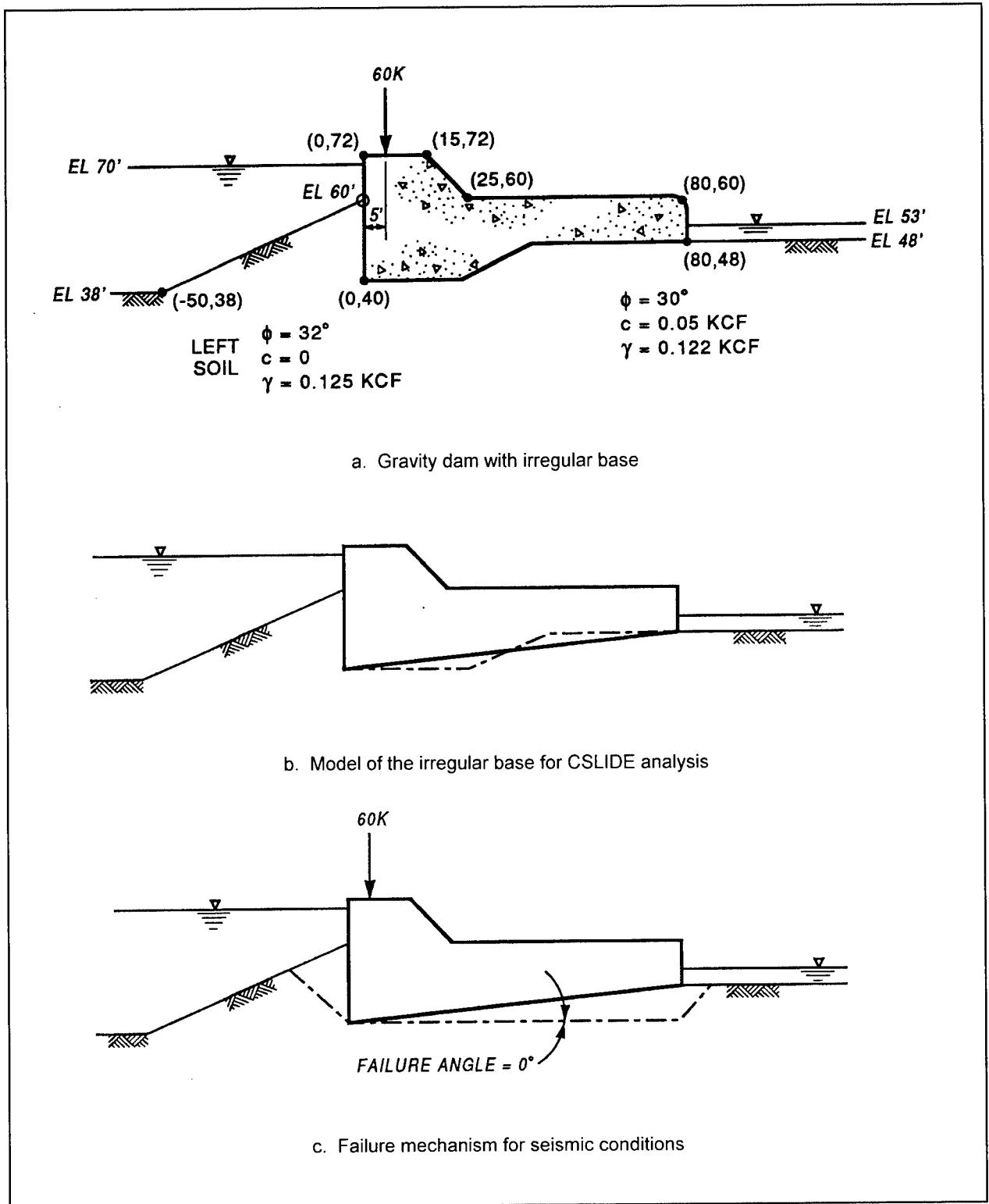

Figure B43. Gravity dam

Problem output

Factor of Safety. The output screen displaying the factor of safety against sliding of the dam is shown in Figure B44.

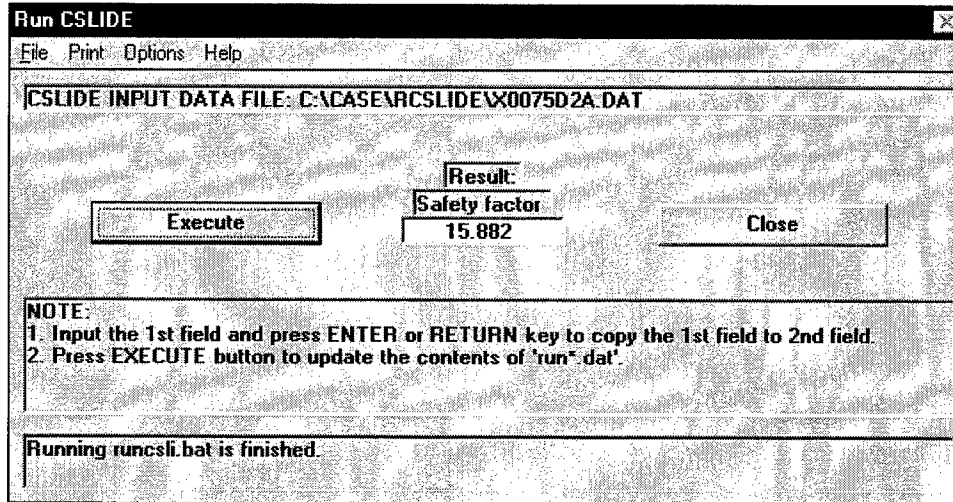

Figure B44. Problem 2A factor of safety

Output file, X0075D2A.out

```
-----  
PROGRAM CSLIDE - ECHOPRINT  
-----  
  
DATE: 13-APR-1999                TIME: 10.23.07  
  
CSLIDE DAM -- PROBLEM 2A  
  
  
SINGLE FAILURE PLANE ANALYSIS  
  
SEEPAGE FORCE BY LINE OF CREEP, GRADIENT  
COMPUTED USING SHORTEST SEEPAGE PATH.  
  
NO OF CORNERS IN STRUCTURE ----- 6  
DENSITY OF CONCRETE ----- .1500 (KCF)  
DENSITY OF WATER ----- .0625 (KCF)  
WATER LEVEL LEFT SIDE ----- 70.00 (FT)  
WATER LEVEL RIGHT SIDE ----- 53.00 (FT)  
NO. OF SOIL LAYERS LEFT SIDE ----- 1  
NO. OF SOIL LAYERS RIGHT SIDE ----- 1
```

ELEV. OF WEDGE-STRUCTURE INTERSECTION
ON ACTIVE SIDE OF STRUCTURE ----- 40.000 (FT)

STRUCTURE INFORMATION

POINT	X-COORD	Y-COORD
1	.00	40.00
2	.00	72.00
3	15.00	72.00
4	25.00	60.00
5	80.00	60.00
6	80.00	48.00

LEFT-SIDE SOIL DATA

LAYER NO.	FRICTION ANGLE (DEG)	COHESION (KSF)	UNIT WEIGHT (KCF)	ELEV AT STRUCTURE (FT)
1	32.00	.0000	.125	60.00

LAYER NO	POINT NO. 1 X-COORD	POINT NO. 1 Y-COORD	POINT NO. 2 X-COORD	POINT NO. 2 Y-COORD
1	-400.00	38.00	-50.00	38.00

SOIL DATA BELOW STRUCTURE

FRICTION ANGLE ----- 30.00
COHESION ----- .0500

RIGHT-SIDE SOIL DATA

LAYER NO.	FRICTION ANGLE (DEG)	COHESION (KSF)	UNIT WEIGHT (KCF)	ELEV AT STRUCTURE (FT)
1	30.00	.0500	.122	48.00

LAYER NO	POINT NO. 1 X-COORD	POINT NO. 1 Y-COORD
1	400.00	48.00

VERTICAL POINT LOADS

X-COORDINATE (FT)	MAGNITUDE (KIPS)
5.00	60.000

PROGRAM CSLIDE - FINAL RESULTS

DATE: 13-APR-1999

TIME: 10.23.07

CSLIDE DAM -- PROBLEM 2A

SINGLE FAILURE PLANE ANALYSIS

SEEPAGE FORCE COMPUTED BY LINE OF CREEP

WEDGE NUMBER	HORIZONTAL LOADS		VERTICAL LOAD (KIPS)
	LEFT SIDE (KIPS)	RIGHT SIDE (KIPS)	
1	1.684	.000	3.828
2	3.125	.781	60.000
3	.000	.000	.000

WATER PRESSURES ON WEDGES

LEFT-SIDE WEDGES

WEDGE NO.	TOP PRESSURE (KSF)	BOTTOM PRESSURE (KSF)
1	.775	1.663

STRUCTURAL WEDGE

X-COORD. (FT)	PRESSURE (KSF)
.00	1.663
80.00	.313

RIGHT-SIDE WEDGES

WEDGE NO.	TOP PRESSURE (KSF)	BOTTOM PRESSURE (KSF)
3	.000	.000

WEDGE NUMBER	FAILURE ANGLE (DEG)	TOTAL LENGTH (FT)	WEIGHT OF WEDGE (KIPS)	SUBMERGED LENGTH (FT)	UPLIFT FORCE (KIPS)
1	-72.739	18.424	6.834	18.424	22.466
2	5.711	80.399	228.000	80.399	79.428
3	.000	.000	.000	.000	.000

WEDGE NUMBER	NET FORCE ON WEDGE (KIPS)
-----------------	---------------------------------

1	-34.412
2	34.412
3	.000

SUM OF FORCES ON SYSTEM ---- .000

FACTOR OF SAFETY ----- 15.882

Failure Surface plot (Figure B45).

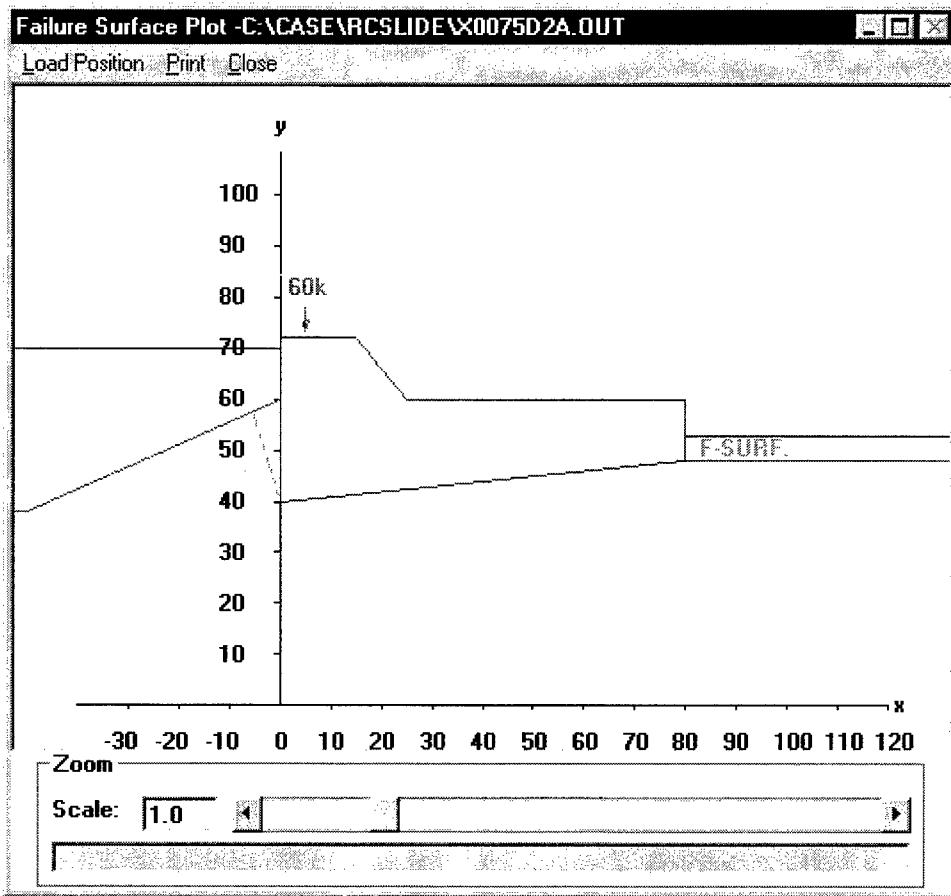

Figure B45. Failure Surface plot

Wedge plots (Figures B46-B48). Note that no right-side wedge is present.

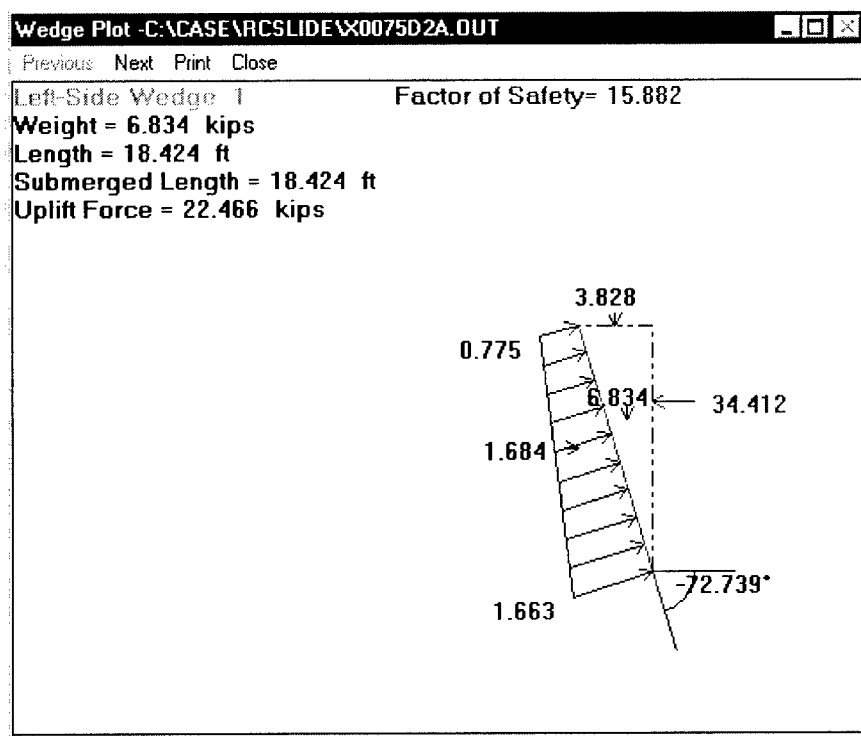

Figure B46. Left-side Wedge 1 Problem 2A

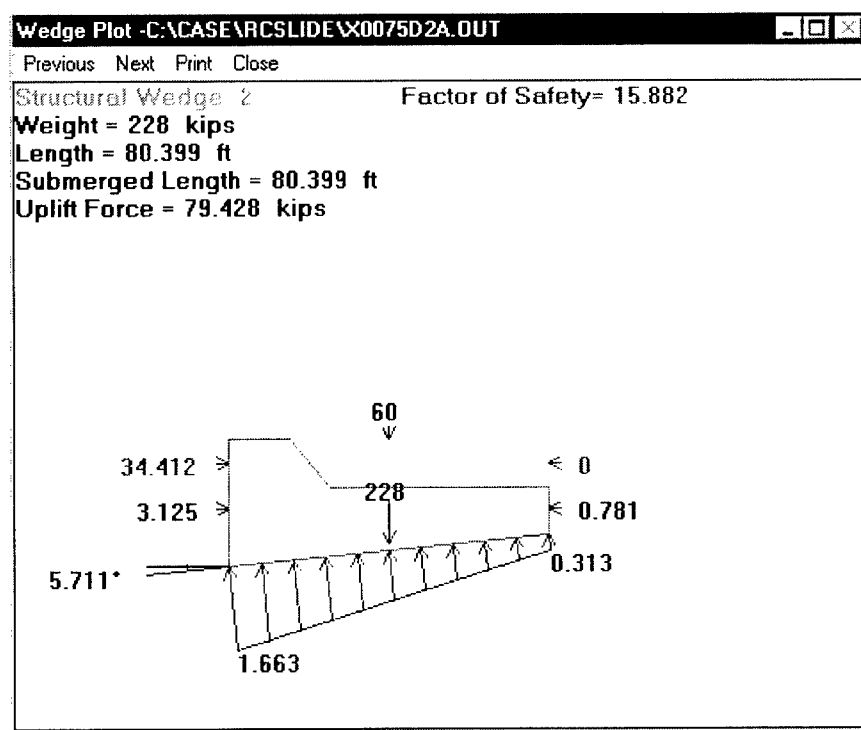

Figure B47. Structural Wedge 2 Problem 2A

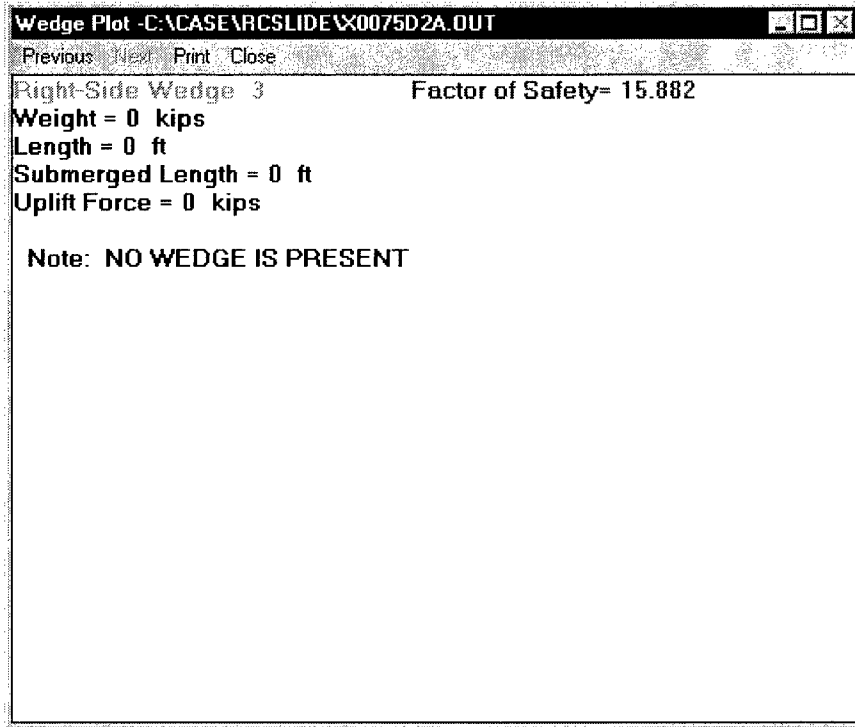

Figure B48. Right-side wedge was not present

Problem 2B

Input file, X0075D2B.dat

```

100 TITL CSLIDE DAM -- PROBLEM 2B
110 STRU 6 .15 40.0 1.0
120 0 40 0 72 15 72 25 60 80 60 80 48
130 SOLT 1 2 32 0 .125 60
140 -400 38 -50 38
150 SOST 30 .05
160 SORT 1 1 30 .05 .122 48
170 400 48
180 METH 1
190 VPLO 5 60
200 WATR 70 53 .0625
210 HOLO 2 .2975 (Horizontal load)
220 EQAC 0.02 0.07 (Earthquake conditions)
230 WEDG 2 0.0 (Wedge-angle specification)
240 END

```

In CSLIDE, earthquake forces are not applied to water that is above the ground surface and/or on the structure. As described in Chapter 5, the user should enter a horizontal force on each wedge in order to have seismic water forces considered in the analysis. Seismic force from water above ground can be calculated from Westerguard's equation:

$$W_{EQ} = (2/3)C_E K_h h^2$$

where

C_E = factor based on the depth of water and defined by the following equation

K_h = horizontal earthquake coefficient

h = height of water

$$C_E = \frac{0.051}{\sqrt{1 - 0.72 \left(\frac{h}{1000T} \right)^2}}$$

where

T = earthquake foundation period of vibration
= 1 sec (avg)

For this example,

$$C_{E_{left}} = \frac{0.051}{\sqrt{1 - 0.72 \left(\frac{10 \text{ ft}}{1000(1 \text{ sec})} \right)^2}} = 0.051 \text{ k - sec - ft}$$

$$C_{E_{right}} = \frac{0.051}{\sqrt{1 - 0.72 \left(\frac{5 \text{ ft}}{1000(1 \text{ sec})} \right)^2}} = 0.051 \text{ k - sec - ft}$$

$$W_{E.Q_{left}} = \frac{2}{3}(0.051) (0.07) (10')^2 = 0.238 \text{ k}$$

$$W_{E.Q_{right}} = \frac{2}{3}(0.051) (0.07) (5')^2 = 0.0595 \text{ k}$$

$$\text{Total } W_{E.Q.} = 0.2975 \text{ k acting to the right}$$

This load is added to the structural wedge as an external horizontal load.

To input a horizontal load, select **Loading Conditions** from the **Edit** menu, and a loading condition window, similar to Figure B49, will appear. Select **Loads** on the menu bar, and Figure B49 will appear for input of the horizontal load values.

Loading Conditions

Loads Delete Print Help

[Load] Loading condition: Horizontal Loads

1. Wedge No.	2. Start-position (ft)	3. Peak-position (ft)	4. End position (ft)	5a. Magnitude (ft/k)
2				0.2975

Enter

1. Wedge No.	2.	3.	4.	5a. Magnitude (k/ft)
Wedge 1				
Wedge 2				0.2975
Wedge 3				
Wedge 4				
Wedge 5				

HOLD 2 is found.

Ok

Figure B49. Horizontal loads window

Earthquake acceleration coefficients can be input by selecting **Earthquake** on the **Edit** menu, and Figure B50 will be displayed for data input.

Earthquakes

Print Help

Enter Acceleration Coefficient Values:

Vertical Acceleration Coefficient 0.02

Horizontal Acceleration Coefficient 0.07

Ok Cancel

Figure B50. Earthquake acceleration coefficients window

A failure angle for any wedge may be specified by selecting **Wedge Angles** on the **Edit** menu, and Figure B51 will be displayed for data input. A failure angle can be set for any wedge in the problem.

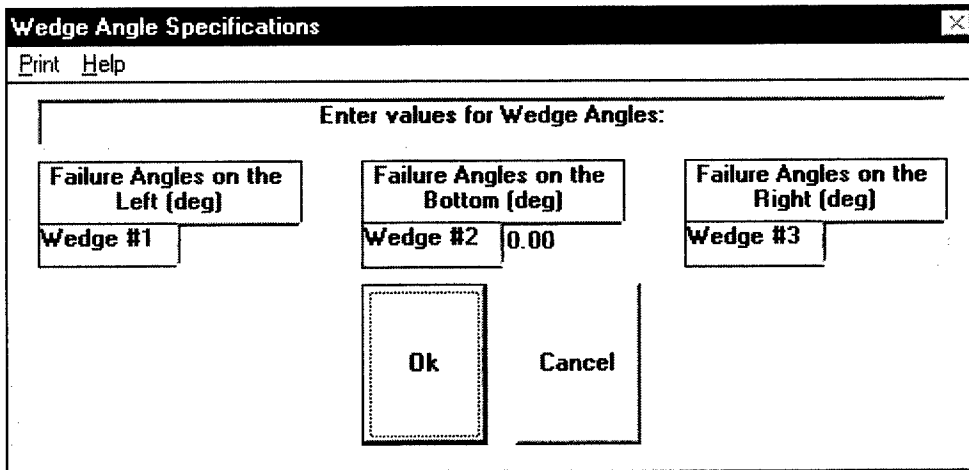

Figure B51. Wedge-angle specifications window

Problem Output

Factor of Safety. The factor of safety for the dam against seismic conditions is given in Figure B52.

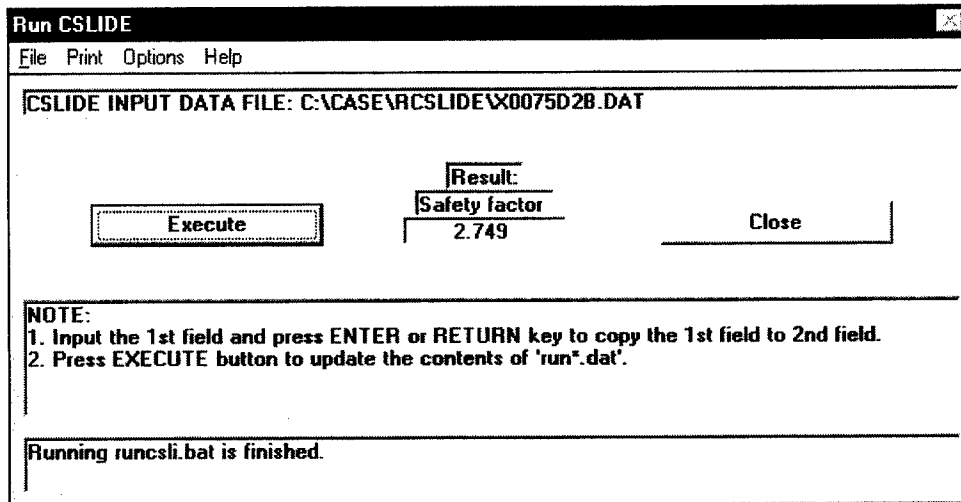

Figure B52. Safety factor for Problem 2B

Because of the earthquake loading, there is a large safety factor decrease from the first analysis in part A. The message “Input structural angle, extended, intersects below the side of the structural wedge at (80.00,40.00)” that is shown in the output file states the coordinate point at which the failure plane of Wedge 3 begins. This can be seen in the output plots that follow.

Output file, X0075D2B.out

PROGRAM CSLIDE - ECHOPRINT

DATE: 13-APR-1999

TIME: 10.43.49

CSLIDE DAM -- PROBLEM 2B

SINGLE FAILURE PLANE ANALYSIS

SEEPAGE FORCE BY LINE OF CREEP, GRADIENT
COMPUTED USING SHORTEST SEEPAGE PATH.

NO OF CORNERS IN STRUCTURE ----- 6
DENSITY OF CONCRETE ----- .1500 (KCF)
DENSITY OF WATER ----- .0625 (KCF)
WATER LEVEL LEFT SIDE ----- 70.00 (FT)
WATER LEVEL RIGHT SIDE ----- 53.00 (FT)
NO. OF SOIL LAYERS LEFT SIDE ----- 1
NO. OF SOIL LAYERS RIGHT SIDE ----- 1

ELEV. OF WEDGE-STRUCTURE INTERSECTION
ON ACTIVE SIDE OF STRUCTURE ----- 40.000 (FT)

STRUCTURE INFORMATION

POINT X-COORD Y-COORD

1 .00 40.00
2 .00 72.00
3 15.00 72.00
4 25.00 60.00
5 80.00 60.00
6 80.00 40.00

LEFT-SIDE SOIL DATA

LAYER FRICTION COHESION UNIT ELEV AT
NO. ANGLE (KSF) WEIGHT STRUCTURE
 (DEG) (KCF) (FT)

1 32.00 .0000 .125 60.00

LAYER NO	POINT NO. 1		POINT NO. 2	
	X-COORD	Y-COORD	X-COORD	Y-COORD
1	-400.00	38.00	-50.00	38.00

SOIL DATA BELOW STRUCTURE

FRICITION ANGLE ----- 30.00
COHESION ----- .0500

RIGHT-SIDE SOIL DATA

LAYER NO.	FRICITION ANGLE (DEG)	COHESION (KSF)	UNIT WEIGHT (KCF)	ELEV AT STRUCTURE (FT)
1	30.00	.0500	.122	48.00

LAYER NO	POINT NO. 1 X-COORD	POINT NO. 1 Y-COORD
1	400.00	48.00

WEDGE NO.	ANGLE
2	.00

SEISMIC ACCELERATIONS

VERTICAL ----- .020
HORIZONTAL ----- .070

VERTICAL POINT LOADS

X-COORDINATE (FT)	MAGNITUDE (KIPS)
5.00	60.000

HORIZONTAL LOADS

WEDGE NO	LOAD
2	.298

PROGRAM CSLIDE - FINAL RESULTS

DATE: 13-APR-1999

TIME: 10.23.49

CSLIDE DAM -- PROBLEM 2B

SINGLE FAILURE PLANE ANALYSIS

SEEPAGE FORCE COMPUTED BY LINE OF CREEP

WEDGE NUMBER	HORIZONTAL LOADS		VERTICAL LOAD (KIPS)
	LEFT SIDE (KIPS)	RIGHT SIDE (KIPS)	
1	4.308	.000	8.025
2	26.315	.781	105.581
3	.474	.000	4.472

WATER PRESSURES ON WEDGES

LEFT-SIDE WEDGES

WEDGE NO.	TOP PRESSURE (KSF)	BOTTOM PRESSURE (KSF)
1	.904	1.678

STRUCTURAL WEDGE

X-COORD. PRESSURE
(FT) (KSF)

.00 1.678
80.00 .891

RIGHT-SIDE WEDGES

WEDGE NO. TOP PRESSURE BOTTOM PRESSURE
 (KSF) (KSF)

3 .313 .891

WEDGE NUMBER	FAILURE ANGLE (DEG)	TOTAL LENGTH (FT)	WEIGHT OF WEDGE (KIPS)	SUBMERGED LENGTH (FT)	UPLIFT FORCE (KIPS)
--------------	---------------------	-------------------	------------------------	-----------------------	---------------------

1	-56.800	18.558	12.702	18.558	23.965
2	.000	80.000	228.000	80.000	02.778
3	29.962	16.019	6.772	16.019	9.641

INPUT STRUCTURAL ANGLE, EXTENDED, INTERSECTS
BELOW THE SIDE OF THE STRUCTURAL WEDGE AT
----- (80.00, 40.00)

WEDGE NUMBER	NET FORCE ON WEDGE (KIPS)
--------------	---------------------------

1	-31.704
2	24.393
3	7.311

SUM OF FORCES ON SYSTEM ---- .000

FACTOR OF SAFETY ----- 2.749

Structure plot (Figure B53).

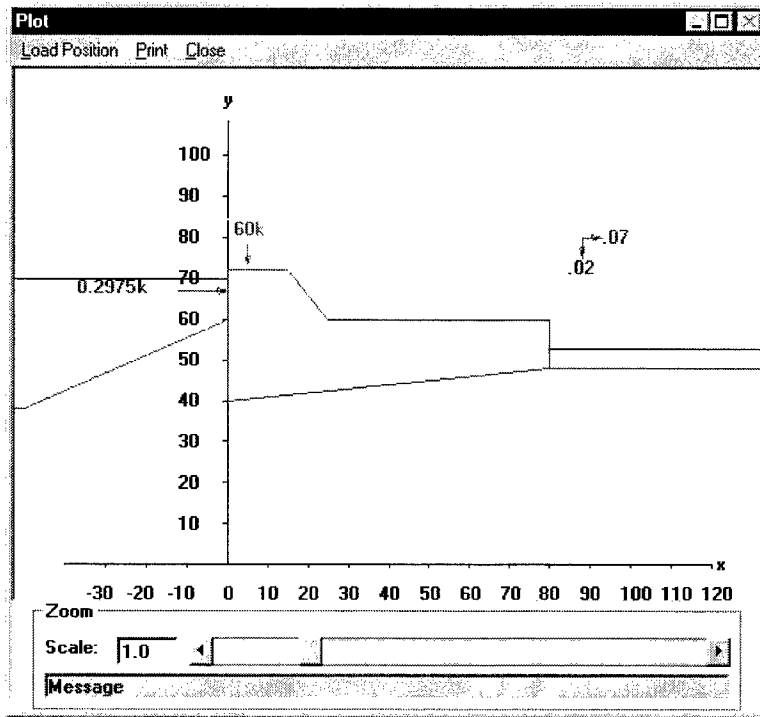

Figure B53. Structure plot (Problem 2B)

Failure Surface plot (Figure B54).

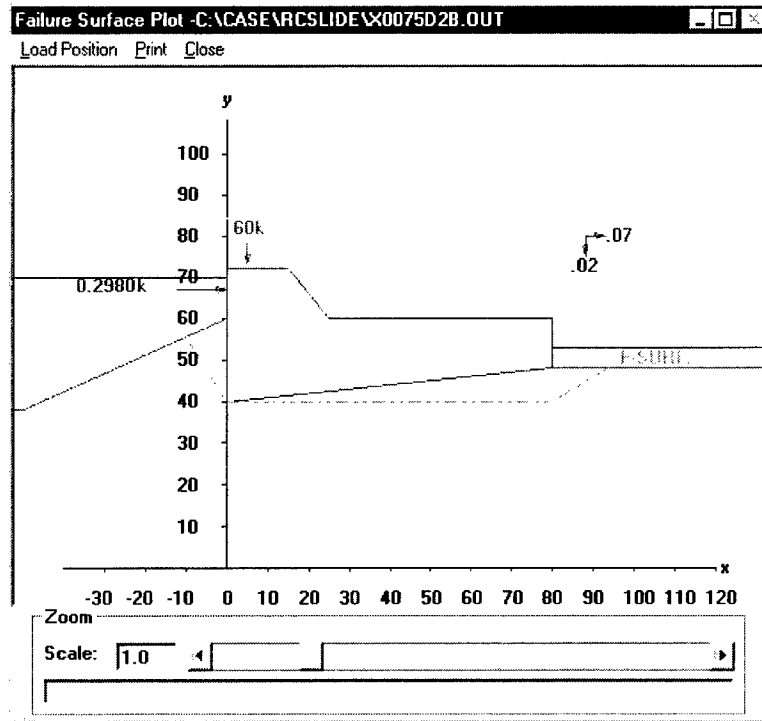

Figure B54. Failure Surface plot (Problem 2B)

Wedge plots (Figures B55-B57).

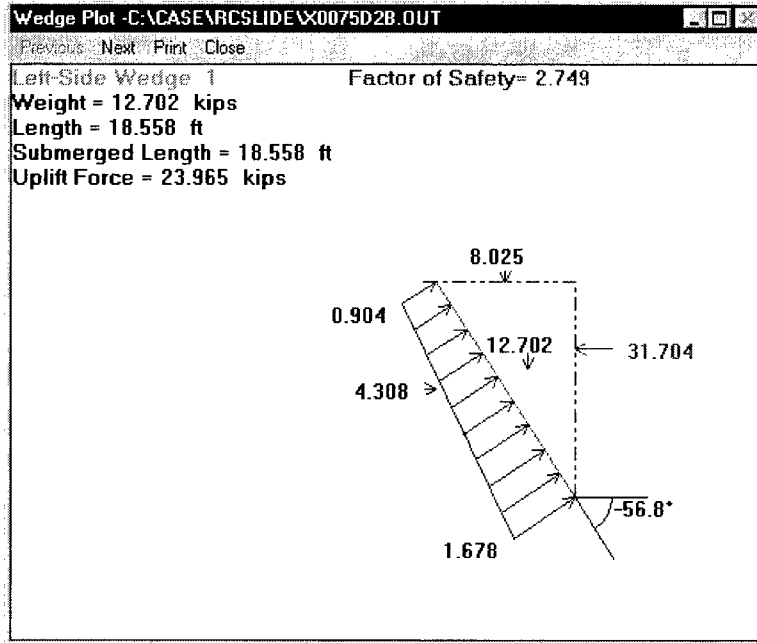

Figure B55. Left-side wedge Problem 2B

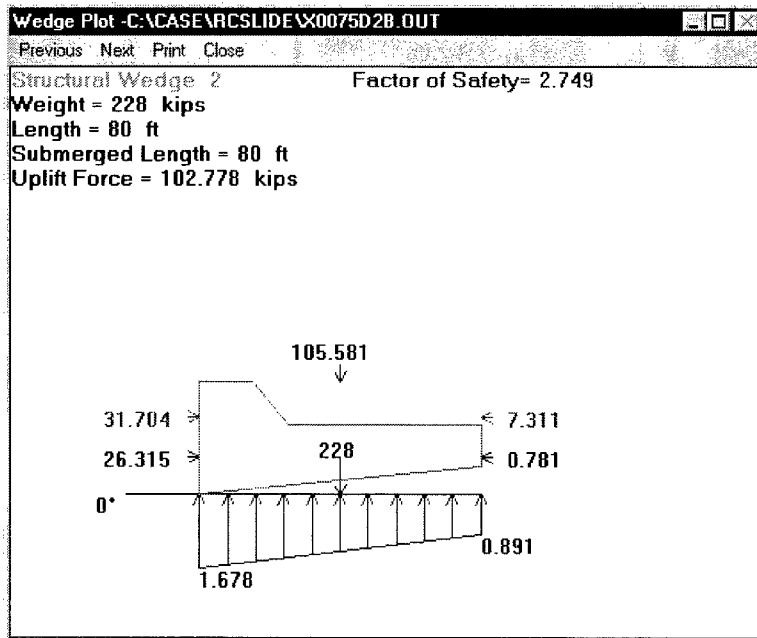

Figure B56. Structural wedge Problem 2B

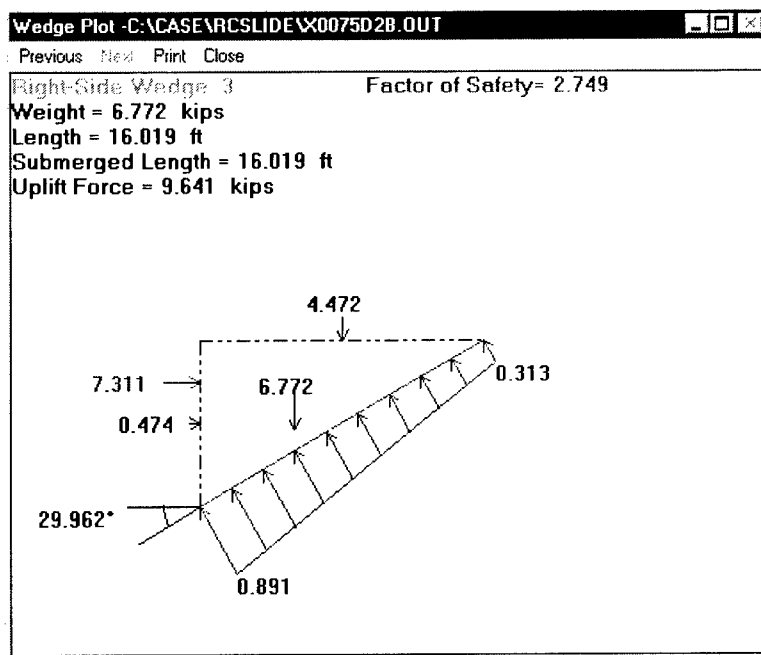

Figure B57. Right-side wedge Problem 2B

The calculation of vertical and horizontal loads when earthquake conditions are used are as follows:

Vertical earthquake load = (Vertical earthquake coefficient) (total weight of wedge + external vertical loads other than water)

Horizontal earthquake load = (Horizontal earthquake coefficient) (total weight of wedge + external vertical loads other than water)

Any water load on top of the wedge is not included in these calculations.

The resultant loads on each wedge, shown in CSLIDE output, are composed of several individual loads described below:

$V_{total} = \text{vertical earthquake load} + \text{external vertical loads} + \text{vertical water load}$

$H_{left\ total} = \text{positive (direction) external horizontal loads} + \text{left-side horizontal water load}$

$H_{right\ total} = \text{negative (direction) external horizontal loads} + \text{right-side horizontal water load}$

The horizontal earthquake load is added to H_{left} if EQHO is positive; whereas, it is

added to H_{right} if EQHO is negative.

Hand Check—Problem 2B, Earthquake Conditions Computations for External Loads Only

Since the depth of the wall is one foot, all calculations are made for a unit depth of one foot and the units are expressed accordingly.

Wedge 1

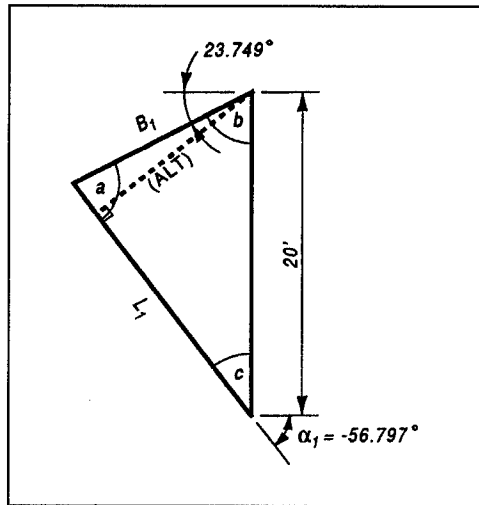

a. Angles:

$$c = 33.203^\circ$$

$$b = 66.251^\circ$$

$$a = 80.546^\circ$$

Figure B58. Wedge 1

$$\frac{\sin c}{B_1} = \frac{\sin a}{20} = \frac{\sin b}{L_1} \quad \therefore \quad L_1 = 18588$$

$$B_1 = 11103$$

$$\text{altitude: } R = (\sin c)(20) = 10952$$

$$\text{Weight: } W_1 = \frac{1}{2}(R)(L_1)(0.125 \text{ kcf}) = 12.703 \text{ k}$$

$$EQ_V = 0.02(W_1) = 0.254 \text{ k}$$

$$EQ_H = 0.07(W_1) = 0.899 \text{ k}$$

b. Water Loads (External)

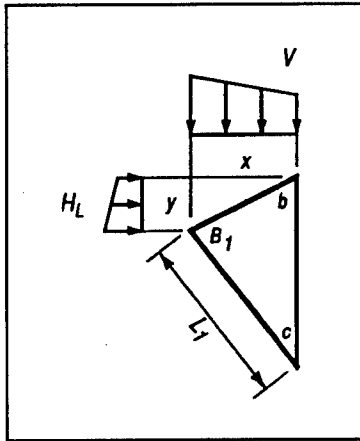

$$x = (\sin c)L_1 = 10.162'$$

$$y = (\cos b)B_1 = 4.472'$$

$$\begin{aligned} \text{Water loads: } V &= \frac{1}{2} [(10 + 4.47)\text{ksf} \\ &\quad + 10\text{ksf}]\gamma_w (10.162') \\ &= 7.771\text{k} \end{aligned}$$

$$\begin{aligned} H_L &= \frac{1}{2} (14.47 + 10)\text{ksf} \gamma_w (4.47') \\ &= 3.420\text{k} \end{aligned}$$

Figure B59. External water loads

c. Totals

$$V_1 = V_w + EQ_v = 7.771 \text{ k} + 0.254 \text{ k} = 8.025 \text{ k}$$

$$H_{L_1} = H_L + EQ_H = 3.420 \text{ k} + 0.889 \text{ k} = 4.309 \text{ k}$$

$$H_{R_1} = 0$$

Wedge 2 – Structure

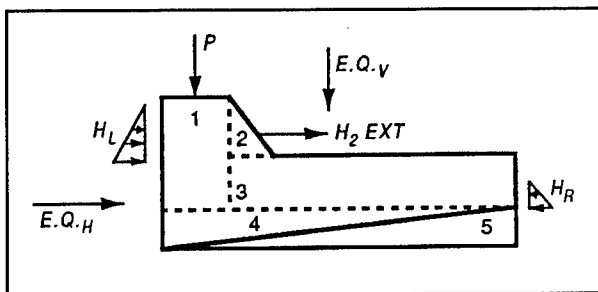

Figure B60. Structural wedge

$$15' \times 24' = 360 \text{ ft}^2$$

$$\frac{1}{2} (10') (12') = 60 \text{ ft}^2$$

$$(65') (12') = 780 \text{ ft}^2$$

$$\frac{1}{2} (80') (8') = 320 \text{ ft}^2$$

$$\text{Total Area} = 1,520 \text{ ft}^2$$

$$\text{Weight : } W_2 = 1520 \text{ ft}^2 (0.15 \text{ kcf}) = 228.0 \text{ k}$$

$$\text{Soil} = \frac{1}{2} (80') (8') = 320 \text{ ft}^2$$

$$\begin{aligned} \text{Weight : } W_{\text{soil}} &= 320 \text{ ft}^2 (0.122 \text{ kcf}) (1 \text{ ft}) \\ &= 39.040 \text{ k} \end{aligned}$$

$$V = 60 \text{ k} \quad (\text{point load})$$

$$EQ_V = 0.02 (W_2 + \text{soil} + V) = 6.541 \text{ k}$$

$$EQ_H = 0.07 (W_2 + \text{soil} + V) = 22.893 \text{ k}$$

$$H_L = 10' \gamma_w \left(\frac{1}{2} \right) (10') = 3.125 \text{ k}$$

$$H_R = 5' \gamma_w \left(\frac{1}{2} \right) (5') = 0.781 \text{ k}$$

$$H_2 = 0.2975 \text{ k} \quad (\text{earthquake acceleration force of water})$$

Total Loads:

$$V_2 = V + \text{soil} + EQ_V = 60 + 39.04 + 6.54 = 105.581 \text{ k}$$

$$H_{L_2} = H_L + EQ_H + H_2 = 3.125 + 22.89 + 0.2975 = 26.316 \text{ k}$$

$$H_{R_2} = H_R = 0.781 \text{ k}$$

Wedge 3

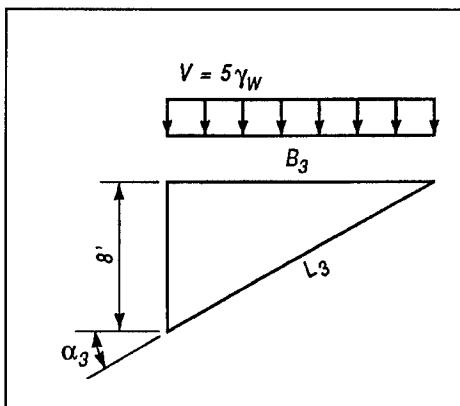

Figure B61. Wedge 3

$$B_3 = \frac{8'}{\tan \alpha_3} = 13.884'$$

$$L_3 = \frac{8'}{\sin \alpha_3} = 16.024'$$

$$\text{Weight: } W_3 = \frac{1}{2} (B_3 \times 8') (0.122 \text{ kcf}) = 6.775 \text{ k}$$

$$EQ_V = 0.02 (W_3) = 0.136 \text{ k}$$

$$EQ_H = 0.07 (W_3) = 0.474 \text{ k}$$

$$V = 5' \gamma_w (B_3) = 4.339 \text{ k}$$

Total Loads:

$$V_3 = V + EQ_V = 4.339 + 0.136 = 4.475 \text{ k}$$

$$H_{L_3} = EQ_H = 0.474 \text{ k}$$

$$\text{Appendix B CSLIDE I } H_{R_3} = 0$$

Table B3
Summary of Problem 2—External Loads and Earthquake
Conditions CSLIDE and Hand Calculations

Wedge No.	Horizontal Loads				Vertical Loads, kips	
	Left, kips		Right, kips			
	CSLIDE	Hand	CSLIDE	Hand	CSLIDE	Hand
1	4.308	4.309	0.000	0.000	8.026	8.025
2	26.315	26.316	0.781	0.781	105.581	105.581
3	0.474	0.474	0.000	0.000	4.472	4.475

Problem 3

The purpose of this example is to demonstrate a way the user can control the failure mechanism in CSLIDE. A structure on a rock ledge is analyzed for sliding stability when the failure plane (a) passes around the rock and (b) passes through the rock. The latter case produces a lower safety factor.

This example also shows that the water elevation on the passive side of the system may be higher than that on the active side. Seepage pressures are distributed from right to left in this case.

Part A. Determine the sliding factor of safety for the system shown in Figure B62a. Assume that the rock is strong in shear relative to the soil, and check the failure plane that passes around the rock ledge on the left side of the structure, as shown in Figure B62b. Only the top three left soil layers should be entered in the analysis. An external horizontal load should be added to the structural wedge to account for the water force on the structure below the elevation of the lowest left-side wedge.

Part B. Determine the sliding factor of safety for the analysis, which includes the rock on the left side in the failure mechanism, as in Figure B62c.

Problem 3A

Input file, X00753A.dat

100	TITL	DAM WITH ROCK BASE (PROB. 3A)					(Title)
110	STRU	5	.15000	12.00	1.00000		(Structural information)
120		.00	.00				(Structural coordinate points)
130		.00	30.00				
140		12.00	30.00				
150		30.00	10.00				
160		30.00	.00				
170	SOLT	1 2	30.00	.00000	.10800	30.00	(Left-side Soil Layer 1 description)
180		-500 35 -50 35					(Soil coordinate points)
190	SOLT	2 1	31.00	.00000	.09500	20.00	(Left-side Soil Layer 2 description)
200		-500 20					(Soil coordinate points)
210	SOLT	3 1	31.00	.00000	.11800	15.00	(Left-side Soil Layer 3 description)
220		-500 15					(Soil coordinate points)
230	SOST	38 .2					(Soil below the structure)
240	SORT	1 1	32.00	.00000	.11500	10.00	(Right-side soil layer description)
250		200 10					(Soil coordinate points)
260	METH	2					(Analysis method)
270	WATR	15.00	22.00	.06250	-1.		(Water description)
280	HOLO	4 7.608					(Horizontal load)
290	END						(Termination)

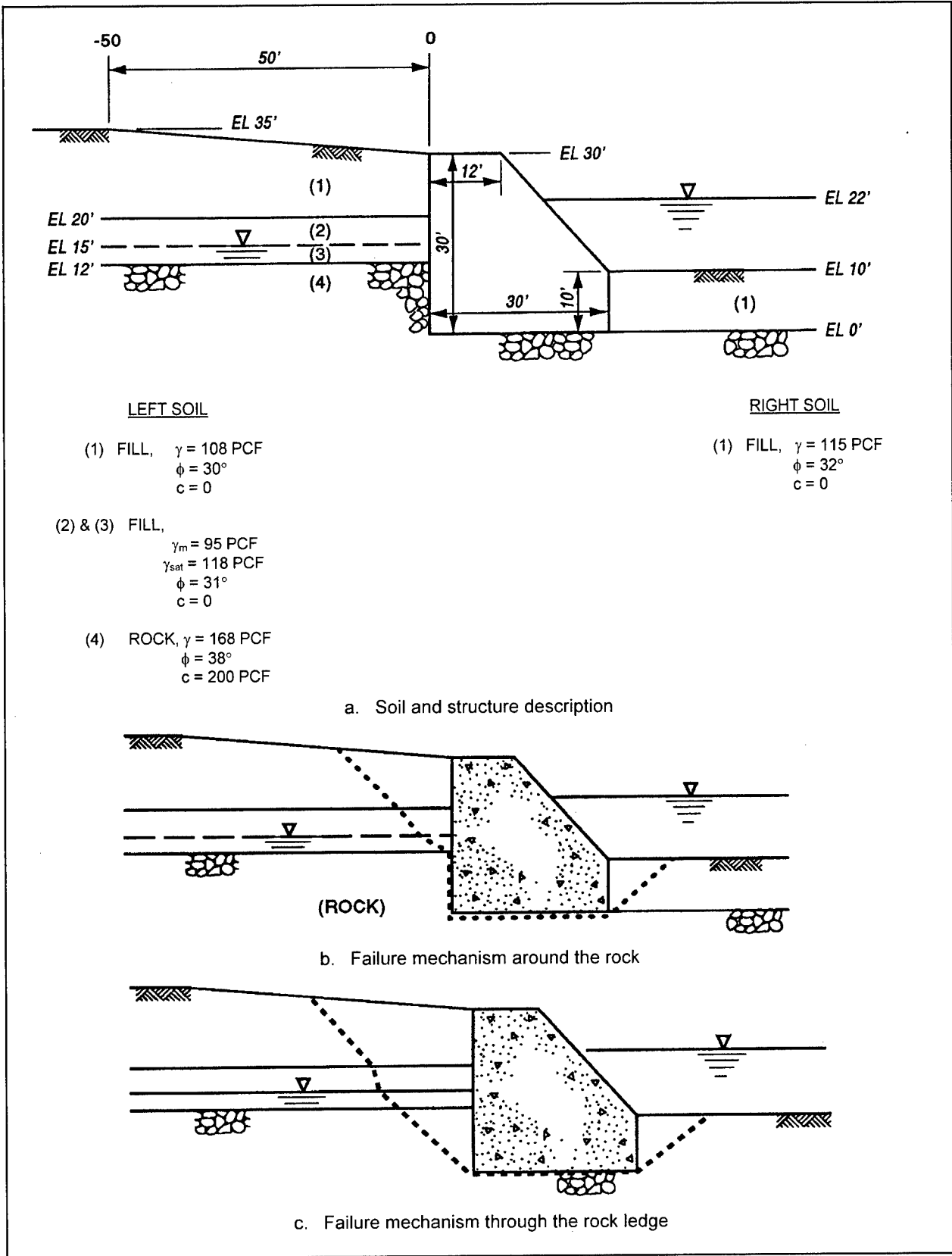

Figure B62. Models for Problem 3 analysis

In order to determine the failure mechanism around the rock, the failure angle elevation at the structure of 12 ft is input as shown in Figure B63, item number 2.

Structural Information [X]

Delete Print Help

1. Unit weight of concrete (kcf):

2. Elevation of failure angle at left side (ft):

3. Fraction of base in compression (<=1):

Point count (max = 20):

[(Clockwise order from lower left corner)] 5. X-coord.:

4. Point Number: 6. Y-coord.:

Node No.	X-coord.	Y-coord.	
Node 1	0.0000	0.0000	▲
Node 2	0.0000	30.0000	
Node 3	12.0000	30.0000	
Node 4	30.0000	10.0000	
Node 5	30.0000	0.0000	▼

C:\CASE\RCSLIDE\X0075D3A.DAT is opened.

Figure B63. Structural information for Problem 3A

Problem output

Factor of safety. Analysis results in a factor of safety of 9.03 (Figure B64).

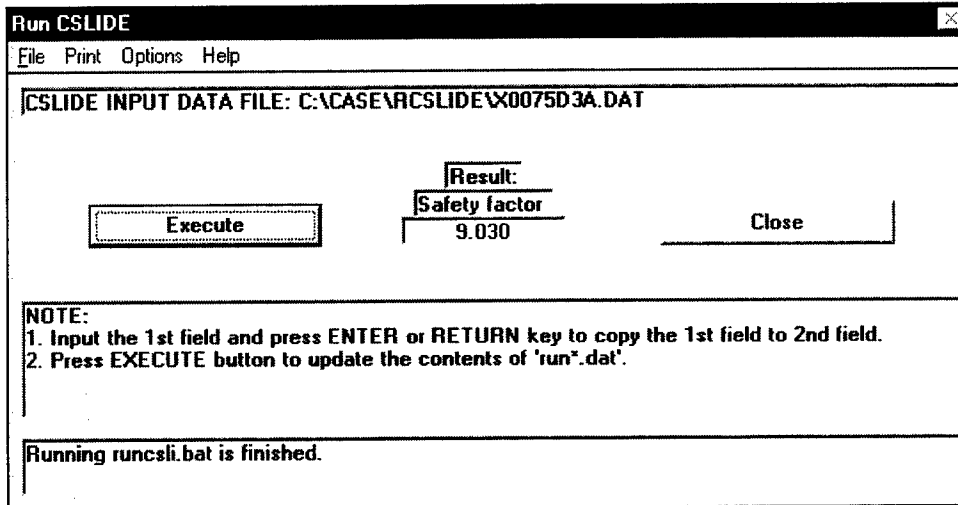

Figure B64. Factor of safety Problem 3A

Output file, X0075d3A.dat

```

-----
PROGRAM CSLIDE - ECHOPRINT
-----

DATE: 13-APR-1999                                TIME: 10.27.00

DAM WITH ROCK BASE (PROB. 3A)

MULTI FAILURE PLANE ANALYSIS

SEEPAGE FORCE BY LINE OF CREEP, GRADIENT
COMPUTED USING SHORTEST SEEPAGE PATH.

NO OF CORNERS IN STRUCTURE ----- 5
DENSITY OF CONCRETE ----- .1500 (KCF)
DENSITY OF WATER ----- .0625 (KCF)
WATER LEVEL LEFT SIDE ----- 15.00 (FT)
WATER LEVEL RIGHT SIDE ----- 22.00 (FT)
NO. OF SOIL LAYERS LEFT SIDE ----- 3
NO. OF SOIL LAYERS RIGHT SIDE ----- 1

ELEV. OF WEDGE-STRUCTURE INTERSECTION
ON ACTIVE SIDE OF STRUCTURE ----- 12.000 (FT)

```

STRUCTURE INFORMATION

POINT	X-COORD	Y-COORD
1	.00	.00
2	.00	30.00
3	12.00	30.00
4	30.00	10.00
5	30.00	.00

LEFT-SIDE SOIL DATA

LAYER NO.	FRICTION ANGLE (DEG)	COHESION (KSF)	UNIT WEIGHT (KCF)	ELEV AT STRUCTURE (FT)
1	30.00	.0000	.108	30.00
2	31.00	.0000	.095	20.00
3	31.00	.0000	.118	15.00

LAYER NO	POINT NO. 1 X-COORD	POINT NO. 1 Y-COORD	POINT NO. 2 X-COORD	POINT NO. 2 Y-COORD
1	-500.00	35.00	-50.00	35.00
2	-500.00	20.00	*****	*****
3	-500.00	15.00	*****	*****

SOIL DATA BELOW STRUCTURE

FRICTION ANGLE ----- 38.00
 COHESION ----- .2000

RIGHT-SIDE SOIL DATA

LAYER NO.	FRICTION ANGLE (DEG)	COHESION (KSF)	UNIT WEIGHT (KCF)	ELEV AT STRUCTURE (FT)
1	32.00	.0000	.115	10.00

LAYER NO	POINT NO. 1 X-COORD	POINT NO. 1 Y-COORD
1	200.00	10.00

HORIZONTAL LOADS

```

-----
WEDGE NO    LOAD
-----
           4      7.608
  
```

PROGRAM CSLIDE - FINAL RESULTS

DATE: 13-APR-1999

TIME: 10.27.00

DAM WITH ROCK BASE (PROB. 3A)

MULTIPLE FAILURE PLANE ANALYSIS

SEEPAGE FORCE COMPUTED BY LINE OF CREEP

WEDGE NUMBER	HORIZONTAL LOADS		VERTICAL LOAD (KIPS)
	LEFT SIDE (KIPS)	RIGHT SIDE (KIPS)	
1	.000	.000	.000
2	.000	.000	.000
3	.000	.000	.000
4	7.608	4.500	4.050
5	.000	.000	8.015

WATER PRESSURES ON WEDGES

LEFT-SIDE WEDGES

WEDGE NO.	TOP PRESSURE (KSF)	BOTTOM PRESSURE (KSF)
1	.000	.000
2	.000	.000
3	.000	.211

STRUCTURAL WEDGE

X-COORD. PRESSURE
(FT) (KSF)

.00 1.057
30.00 1.295

RIGHT-SIDE WEDGES

WEDGE NO. TOP PRESSURE BOTTOM PRESSURE
 (KSF) (KSF)

5 .750 1.295

WEDGE FAILURE TOTAL WEIGHT SUBMERGED UPLIFT
NUMBER ANGLE LENGTH OF WEDGE LENGTH FORCE
 (DEG) (FT) (KIPS) (FT) (KIPS)

--

1	-15.8	55.089	33.635	.000	.000
2	-42.4	7.415	7.555	.000	.000
3	-44.8	4.258	5.282	4.258	.450
4	.000	30.000	108.000	30.000	35.284
5	43.1	14.635	6.145	14.635	14.968

WEDGE NET FORCE
NUMBER ON WEDGE
 (KIPS)

1	-7.236
2	-6.029
3	-4.630
4	4.198
5	13.698

SUM OF FORCES ON SYSTEM ---- .001

FACTOR OF SAFETY ----- 9.030

Structure plot (Figure B65).

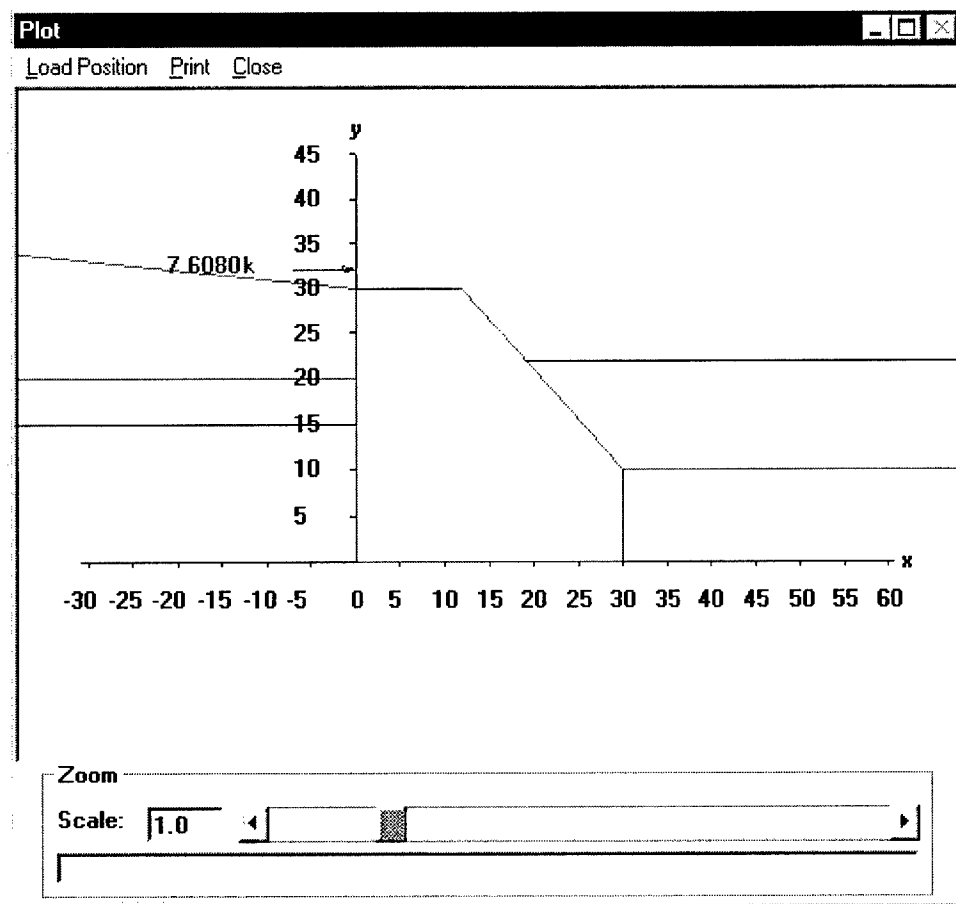

Figure B65. Structure plot – Problem 3A

Failure Surface plot (Figure B66).

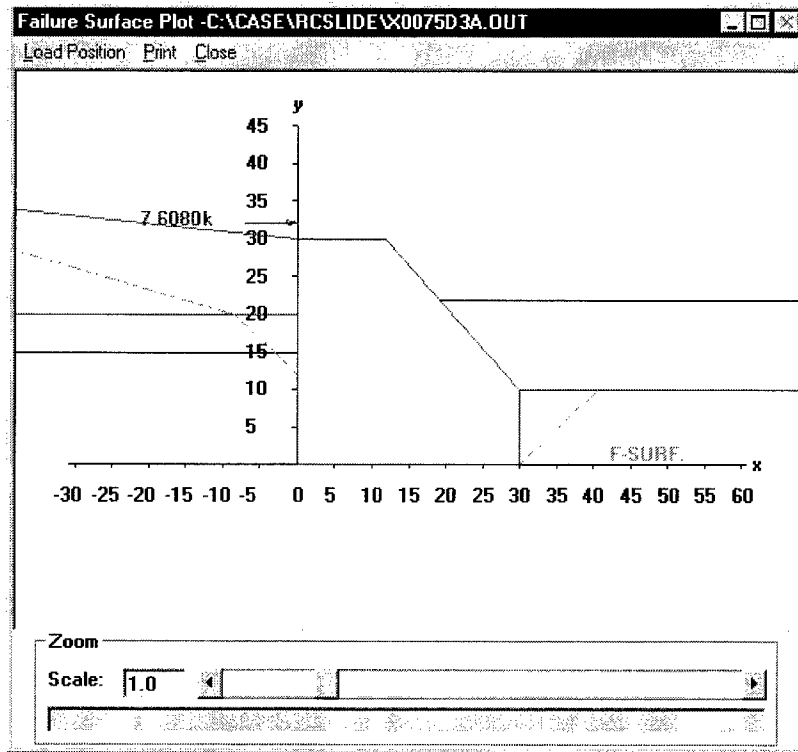

Figure B66. Failure Surface plot – Problem 3A

Wedge plots (Figures B67-B71).

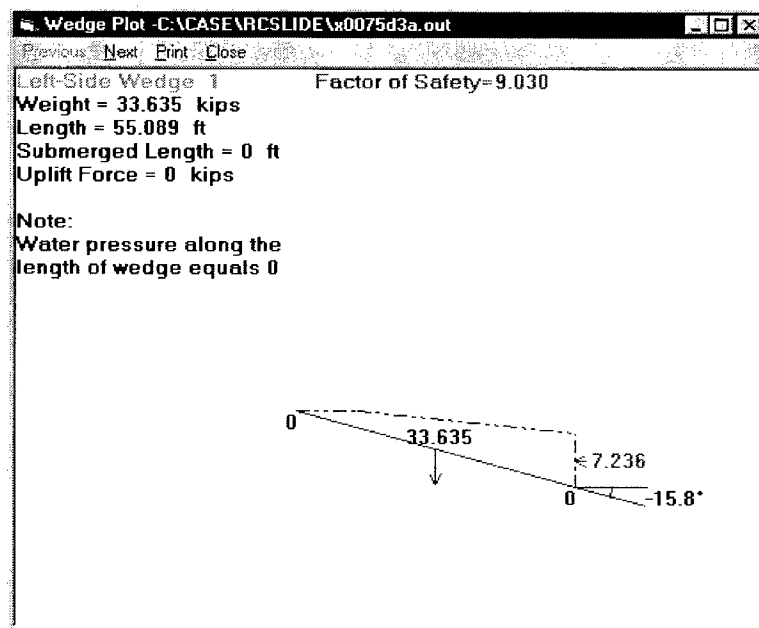

Figure B67. Left-side Wedge 1 Problem 3A

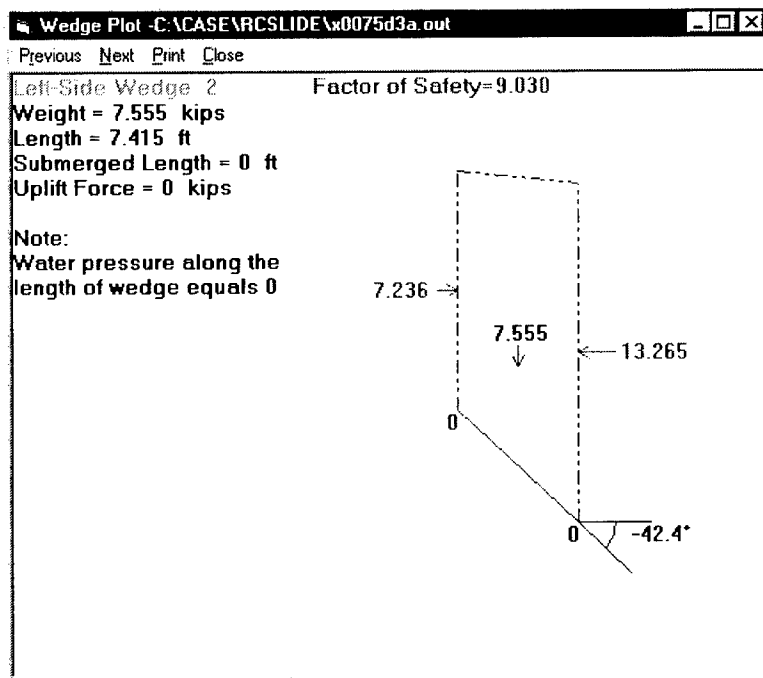

Figure B68. Left-side Wedge 2 Problem 3A

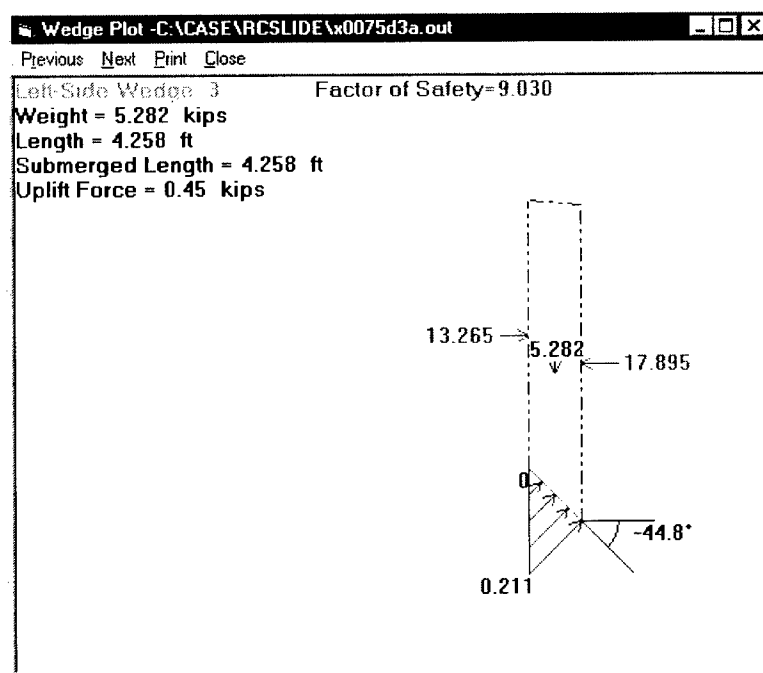

Figure B69. Left-side Wedge 3 Problem 3A

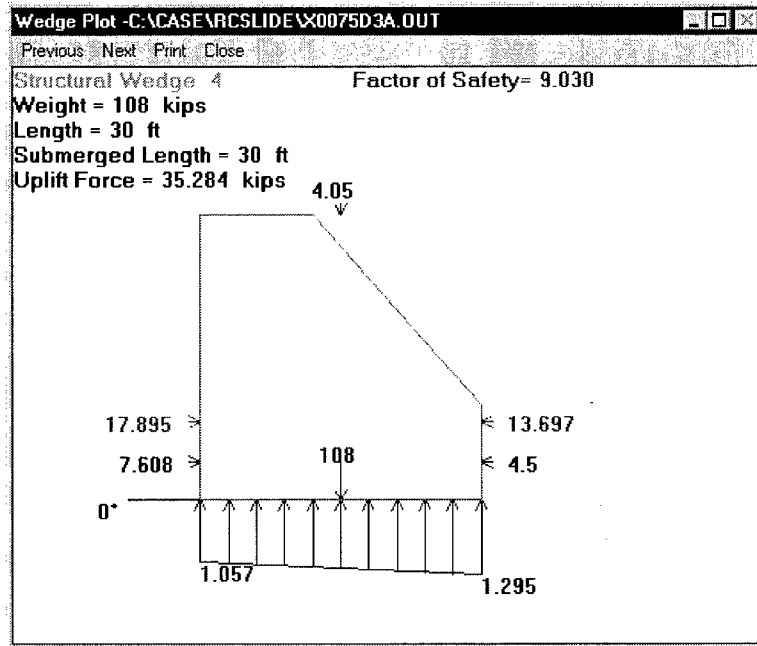

Figure B70. Structural Wedge 4 Problem 3A

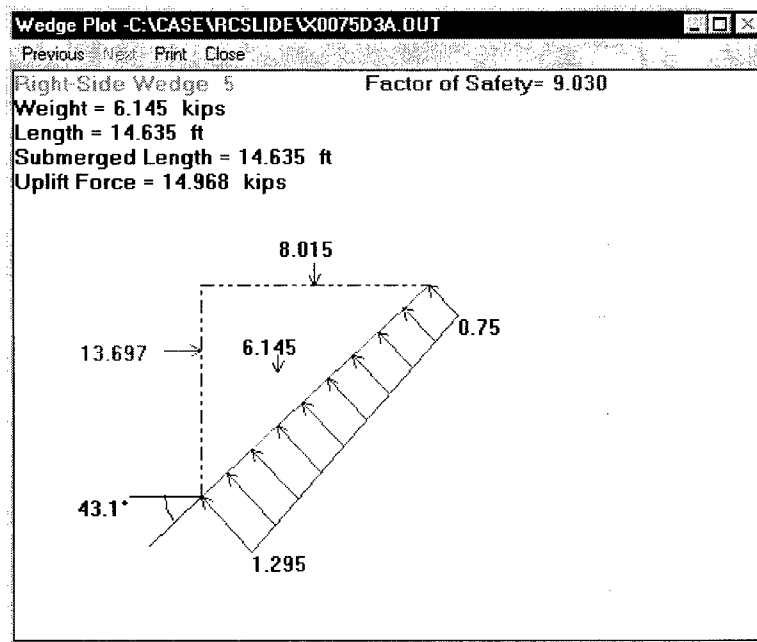

Figure B71. Right-side Wedge 5 Problem 3A

Problem 3B

To analyze the failure surface through the rock, the elevation of the failure angle and the horizontal load have been removed, and a fourth left-side soil layer (Figures B72-B73) is added.

Soil Property Description

Print Help

Method: Side:

Total layers:

1. Layer number (max=5):

2. Total points (max=5):

3. Angle of internal friction of the layer (deg):

4. Cohesion of the layer (ksf):

5. Saturated or moist unit weight (kcf):

6. Elevation of the top of the layer (ft):

Figure B72. Soil property description for Layer 4, Problem 3B

Soil Coordinate Description

Print Help

[Side] Soil description:

Total layers:

1. Layer number (max=5):

2. Point No. (max=5):

3. X-coord.:

4. Y-coord.:

	X-coord.	Y-coord.	
Layer (1)			▲
Point 1	-500.0000	35.0000	
Point 2	-50.0000	35.0000	
Point 3			
Point 4			
Point 5			
Layer (2)			▼
Point 1	500.0000	30.0000	

Figure B73. Soil coordinate description for Layer 4, Problem 3B

Input file, X0075D3B.dat

```
100 TITL DAM WITH ROCK BASE (PROB 3B)
110 STRU 5 .15
120 .00 .00
130 .00 30.00
140 12.00 30.00
150 30.00 10.00
160 30.00 .00
170 SOLT 1 2 30.00 .00000 .10800 30.00
180 -500 35 -50 35
190 SOLT 2 1 31.00 .00000 .09500 20.00
200 -500 20
210 SOLT 3 1 31.00 .00000 .11800 15.00
220 -500 15
230 SOLT 4 1 38.00 .20000 .16800 12.00 (4th left-side layer has been added)
240 -500 12
250 SOST 38 .2
260 SORT 1 1 32.00 .00000 .11500 10.00
270 200 10
280 METH 2
290 WATR 15.00 22.00 .06250 -1.
300 END
```

Problem output

Factor of safety. An analysis of the failure surface through the rock produces a value of 3.32 for the factor of safety (Figure B74). When compared with Problem 3A, the decreased safety factor is a result of the increased driving force, which is due to inclusion of the rock in the failure mechanism.

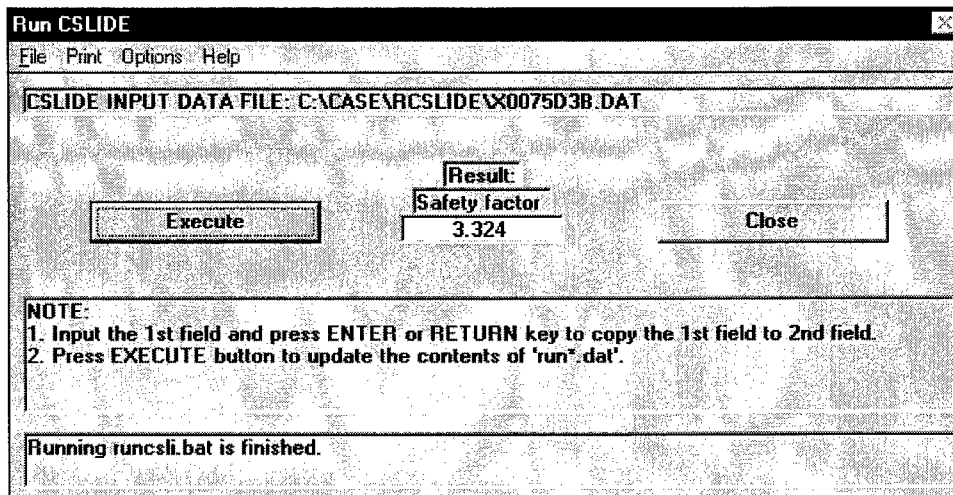

Figure B74. Factor of safety for Problem 3B

Output file, X0075D3B.out

PROGRAM CSLIDE - ECHOPRINT

DATE: 13-APR-1999

TIME: 10.29.00

DAM WITH ROCK BASE (PROB 3B)

MULTI FAILURE PLANE ANALYSIS

SEEPAGE FORCE BY LINE OF CREEP, GRADIENT
COMPUTED USING SHORTEST SEEPAGE PATH.

NO OF CORNERS IN STRUCTURE -----	5
DENSITY OF CONCRETE -----	.1500 (KCF)
DENSITY OF WATER -----	.0625 (KCF)
WATER LEVEL LEFT SIDE -----	15.00 (FT)
WATER LEVEL RIGHT SIDE -----	22.00 (FT)
NO. OF SOIL LAYERS LEFT SIDE -----	4
NO. OF SOIL LAYERS RIGHT SIDE -----	1

ELEV. OF WEDGE-STRUCTURE INTERSECTION ON ACTIVE SIDE OF STRUCTURE -----	.000 (FT)
--	-----------

STRUCTURE INFORMATION

POINT -----	X-COORD -----	Y-COORD -----
1	.00	.00
2	.00	30.00
3	12.00	30.00
4	30.00	10.00
5	30.00	.00

LEFT-SIDE SOIL DATA

LAYER NO.	FRICTION ANGLE (DEG)	COHESION (KSF)	UNIT WEIGHT (KCF)	ELEV AT STRUCTURE (FT)

1	30.00	.0000	.108	30.00
2	31.00	.0000	.095	20.00
3	31.00	.0000	.118	15.00
4	38.00	.2000	.168	12.00

LAYER NO	POINT NO. 1		POINT NO. 2	
	X-COORD	Y-COORD	X-COORD	Y-COORD
1	-500.00	35.00	-50.00	35.00
2	-500.00	20.00	*****	*****
3	-500.00	15.00	*****	*****
4	-500.00	12.00	*****	*****

SOIL DATA BELOW STRUCTURE

 FRICTION ANGLE ----- 38.00
 COHESION ----- .2000

RIGHT-SIDE SOIL DATA

LAYER NO.	FRICITION	COHESION (KSF)	UNIT	ELEV AT
	ANGLE (DEG)		WEIGHT (KCF)	STRUCTURE (FT)
1	32.00	.0000	.115	10.00

LAYER NO	POINT NO. 1	
	X-COORD	Y-COORD
1	200.00	10.00

 PROGRAM CSLIDE - FINAL RESULTS

DATE: 13-APR-1999

TIME: 10.29.00

DAM WITH ROCK BASE (PROB 3B)

MULTIPLE FAILURE PLANE ANALYSIS

SEEPAGE FORCE COMPUTED BY LINE OF CREEP

WEDGE NUMBER	HORIZONTAL LOADS		VERTICAL LOAD (KIPS)
	LEFT SIDE (KIPS)	RIGHT SIDE (KIPS)	
1	.000	.000	.000
2	.000	.000	.000
3	.000	.000	.000
4	.000	.000	.000
5	.000	4.500	4.050
6	.000	.000	9.034

WATER PRESSURES ON WEDGES

LEFT-SIDE WEDGES

WEDGE NO.	TOP PRESSURE (KSF)	BOTTOM PRESSURE (KSF)
1	.000	.000
2	.000	.000
3	.000	.211
4	.211	1.057

STRUCTURAL WEDGE

X-COORD. (FT)	PRESSURE (KSF)
.00	1.057
30.00	1.295

RIGHT-SIDE WEDGES

WEDGE NO.	TOP PRESSURE (KSF)	BOTTOM PRESSURE (KSF)
6	.750	1.295

WEDGE NUMBER	FAILURE ANGLE (DEG)	TOTAL LENGTH (FT)	WEIGHT OF WEDGE (KIPS)	SUBMERGED LENGTH (FT)	UPLIFT FORCE (KIPS)
1	-39.9	20.691	10.016	.000	.000
2	-48.9	6.635	6.438	.000	.000
3	-49.5	3.945	4.748	3.945	.417
4	-50.4	15.574	29.490	15.574	9.875
5	.000	30.000	108.000	30.000	35.284
6	39.7	15.655	6.926	15.655	16.011

WEDGE NUMBER	NET FORCE ON WEDGE (KIPS)
1	-5.794
2	-5.149
3	-3.975
4	-24.052
5	24.350
6	14.620

SUM OF FORCES ON SYSTEM ---- .000

FACTOR OF SAFETY ----- 3.324

Structure plot (Figure B75).

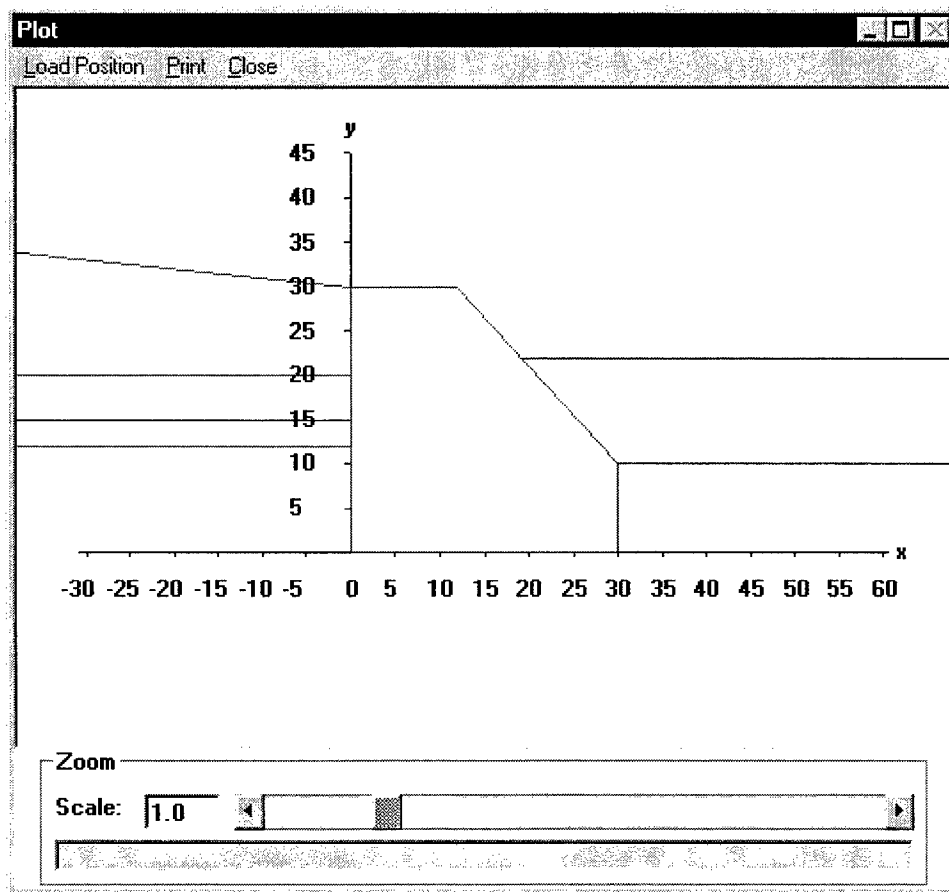

Figure B75. Structure plot

Failure Surface plot (Figure B76).

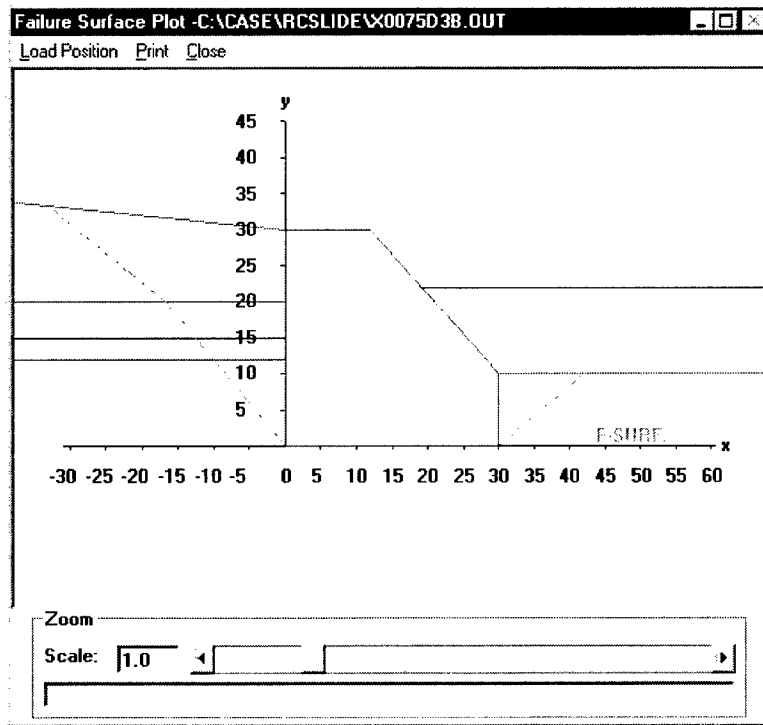

Figure B76. Failure Surface plot – Problem 3B

Wedge plots (Figures B77-B82).

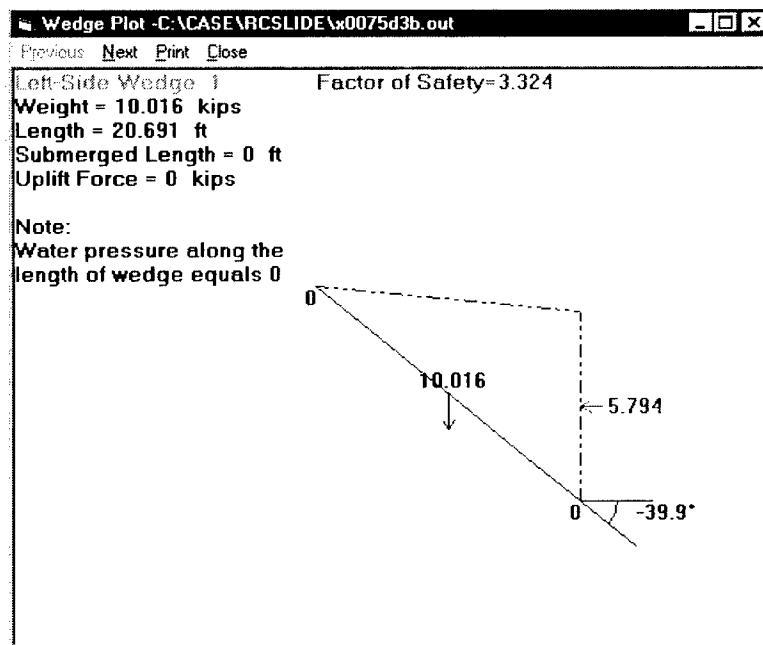

Figure B77. Left-side Wedge 1 Problem 3B

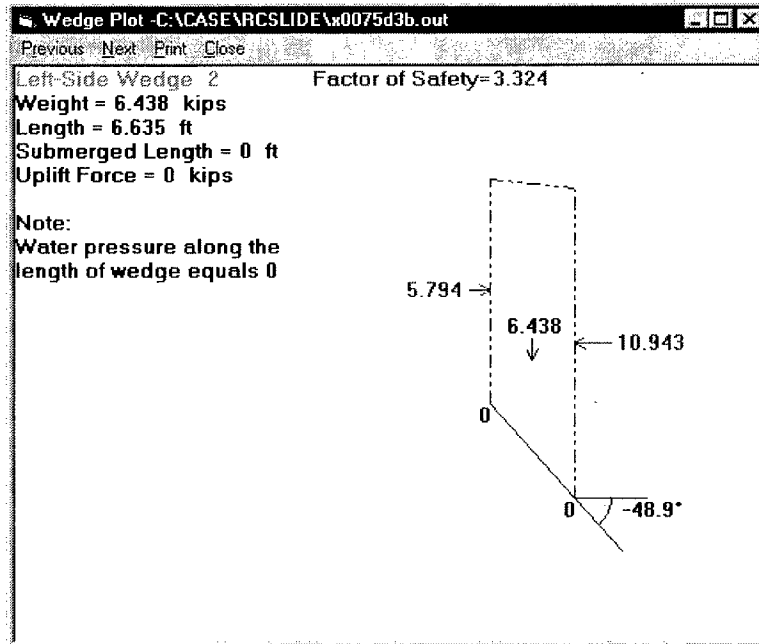

Figure B78. Left-side Wedge 2 Problem 3B

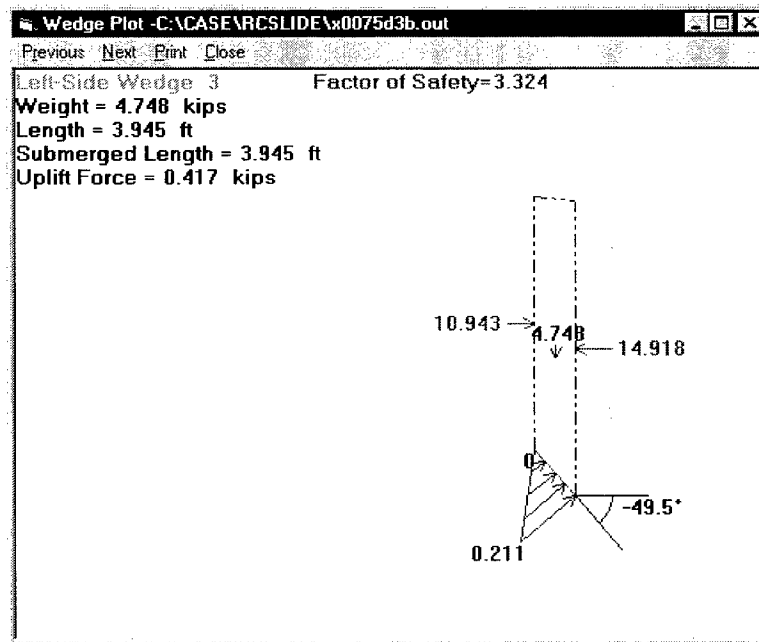

Figure B79. Left-side Wedge 3 Problem 3B

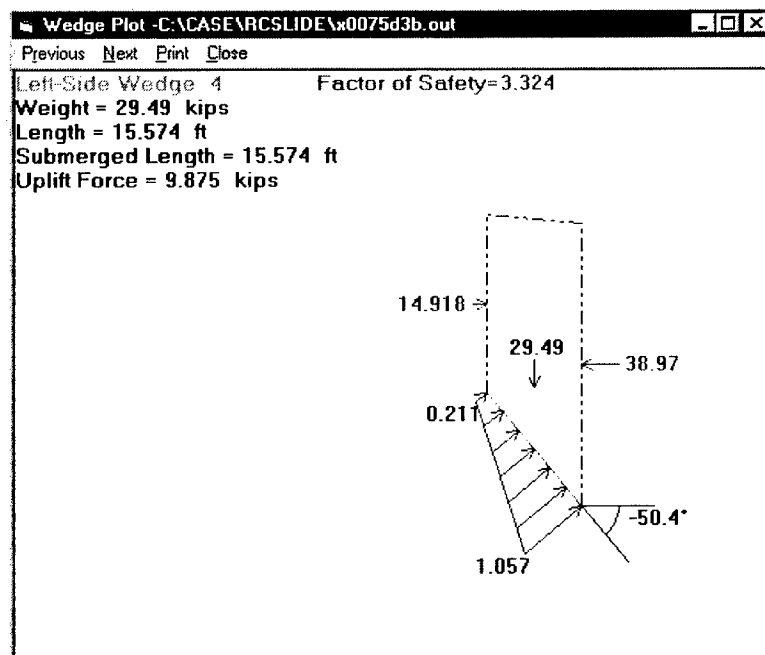

Figure B80. Left-side Wedge 4 Problem 3B

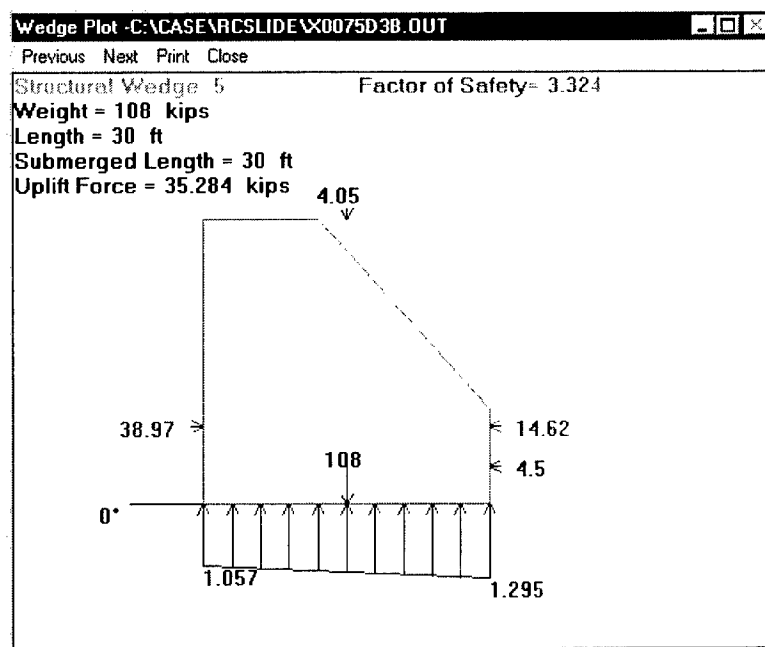

Figure B81. Structural Wedge 5 Problem 3B

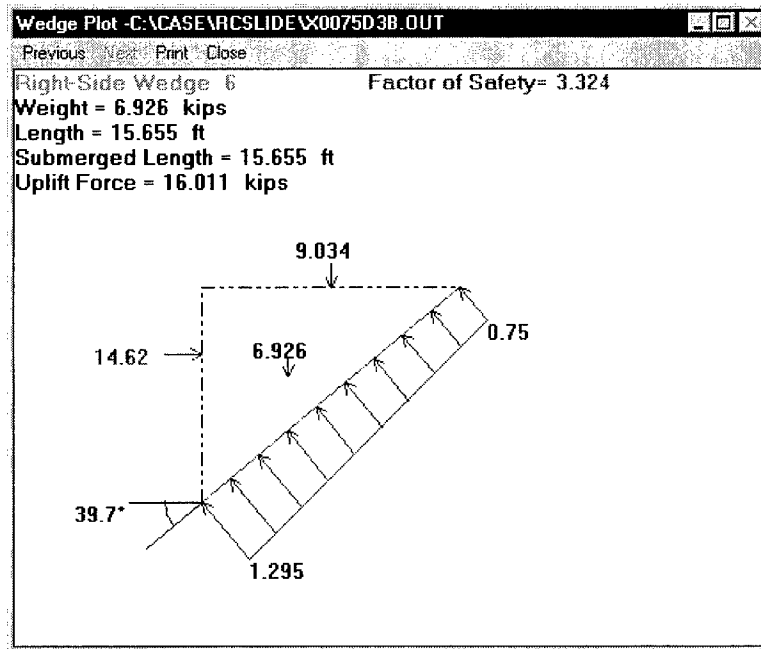

Figure B82. Right-side Wedge 6 Problem 3B

Hand Check—Problem 3, Seepage Calculations for “Reversed” Flow (Passive to Active Side)

Based upon the seepage gradient as depicted in Figure B83 the following line-of-creep seepage calculations for “revised” flow may be performed.

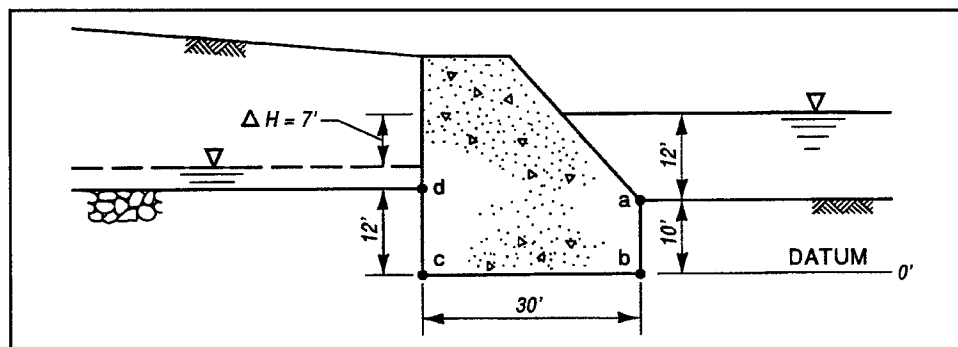

Figure B83. Structure displaying values for seepage gradient

Line-of-Creep.

$$\text{Seepage gradient: } i = \frac{\Delta H}{L} = \frac{22' - 15'}{(10' + 30' + 15')} = 0.127273$$

$$\text{Pressure} = \left(\begin{array}{c} \text{unit} \\ \text{weight} \\ \text{water} \end{array} \right) \left[\left(\begin{array}{c} \text{headwater} \\ \text{elevation} \end{array} \right) - \left(\begin{array}{c} \text{point} \\ \text{elevation} \end{array} \right) - (\text{gradient}) \left(\begin{array}{c} \text{path} \\ \text{length} \end{array} \right) \right]$$

$$P_a = \gamma_w [22' - 10' - i(0)] = 0.750 \text{ ksf}$$

$$P_b = \gamma_w [22' - 0' - i(10')] = 1.295 \text{ ksf}$$

$$P_c = \gamma_w [22' - 0' - i(10' + 30')] = 1.057 \text{ ksf}$$

$$P_d = \gamma_w [22' - 12' - i(10' + 30' + 12')] = 0.211 \text{ ksf}$$

These hand calculations match CSLIDE calculations shown in the output listing for either Problem 3A or 3B.

Problem 4

This example problem demonstrates how to enter precalculated seepage pressures into a CSLIDE analysis. These input pressures are used in the sliding stability analysis, rather than the values calculated by one of the methods within the program. For instance, pressures obtained from a flownet or a finite element seepage analysis may be used as input.

The dam to be analyzed for sliding safety is shown in Figure B84a. As in Problem 2 of this appendix, the irregular base is modeled as a single plane. For simplicity, the joint between the dam and the spillway is ignored, and the structure is treated as a unit in sliding. The analysis model is shown in Figure B84b.

Part A. Find the sliding factor of safety of the dam shown in Figure B84a using the water pressures acting on the wedge vertices and structure base. These pressures are obtained from the flownet shown in Figure B84a.

Part B. Analyze the dam shown in Figure B84a a second time, using water pressures calculated by CSLIDE from the line-of-creep method of analysis.

Part C. Incorporate a vertical anchor into CSLIDE using the dam shown in Figure B84b. The ANCHOR command implemented in CSLIDE requires two input parameters: the anchor force, which is specified in units of kips/ft, i.e., the anchor spacing should be accounted for in the anchor force and the angle of installation in degrees from the vertical position. A positive angle is in the clockwise direction. Up to three ANCHOR commands can be used in CSLIDE. Use a vertical anchor installed in the dam with an anchor force of 60 kips at an angle of 0 deg.

Problem 4A

The dam's base is modeled as a single plane; however, water pressures are calculated along the actual base configuration, shown in Figure B84a. All pressure calculations are as follows:

$$\text{Pressure} = \gamma_w \left(\begin{array}{l} \text{Tailwater} \\ \text{elevation} \end{array} - \begin{array}{l} \text{Elevation of} \\ \text{point of interest} \end{array} + \% \text{ of } \Delta H \text{ remaining} \right)$$

Wedge 1:

$$\begin{aligned} P_a &= (100\% \Delta H) = [64' - 50' + 1.0(31')] \gamma_w \\ &= 2.813 \text{ ksf} \end{aligned}$$

$$\begin{aligned} P_b &= (77\% \Delta H) = [64' - 0' + 0.77(31')] \gamma_w \\ &= 5.492 \text{ ksf} \end{aligned}$$

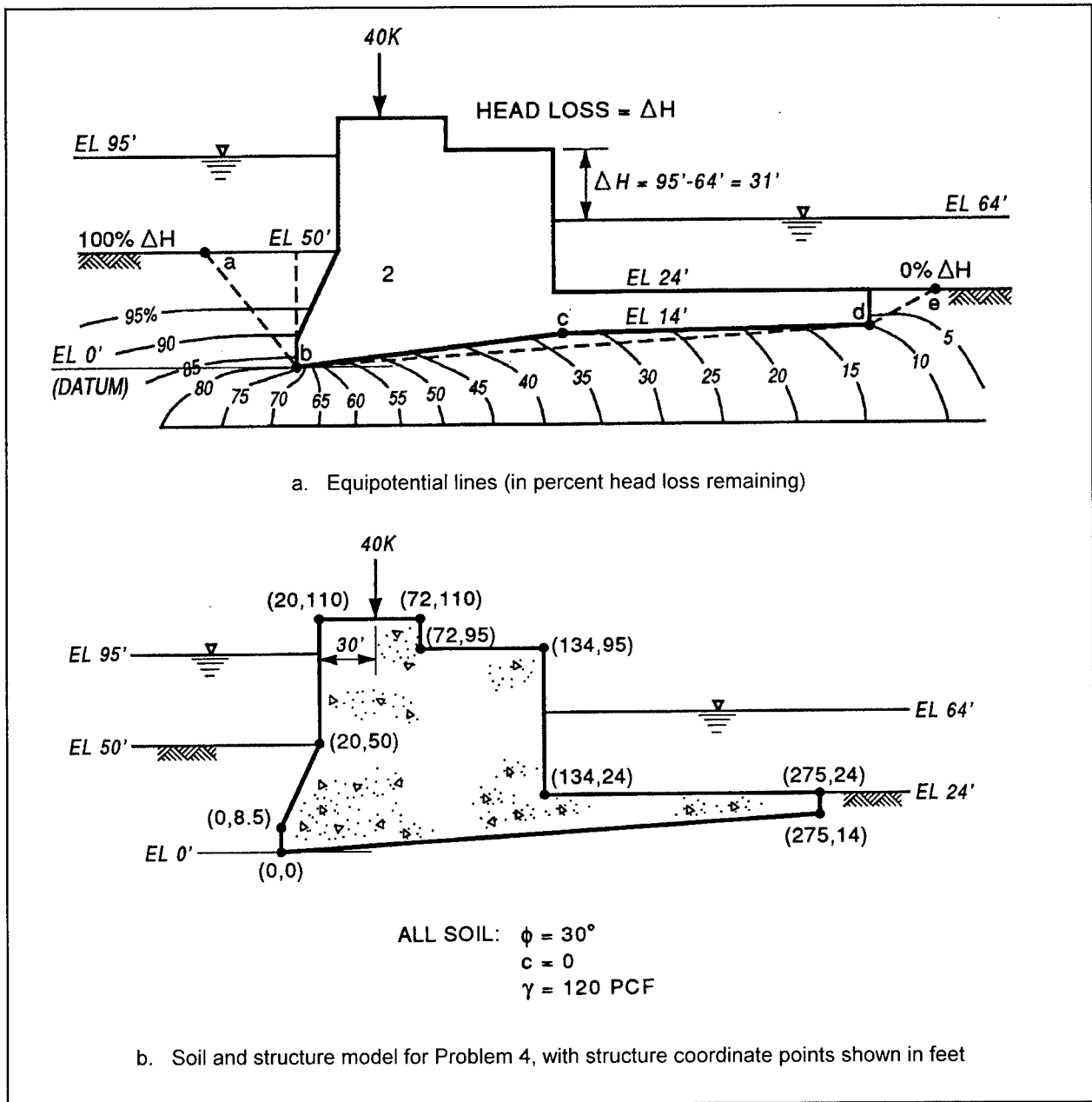

Figure B84. Dam No. 4

Wedge 2:

$$P_b = 5.492 \text{ ksf}$$

$$P_c = (33\% \Delta H) = [64' - 14' + 0.33(31')] \gamma_w$$
$$= 3.764 \text{ ksf}$$

$$P_d = (10\% \Delta H) = [64' - 14' + 0.10(31')] \gamma_w$$
$$= 3.319 \text{ ksf}$$

Wedge 3:

$$P_d = 3.319 \text{ ksf}$$

$$P_e = (0\% \Delta H) = [64' - 24' + 0] \gamma_w$$
$$= 2.50 \text{ ksf}$$

Input file, X0075D4A.dat

100 TITL DAM NO. 4 (PROB 4A)	(Title)
110 STRU 10 .15	(Structural information)
120 0 0 0 8.5 20 50 20 110 72 110	(Coordinate points for structure)
130 72 95 134 95 134 24 275 24 275 14	
140 SOLT 1 1 30 0 .12 50	(Left-side soil layer description)
150 -100 50	(Soil coordinate points)
160 SOST 30 0	(Soil below the structure)
170 SORT 1 1 30 0 .12 24	(Right-side soil layer description)
180 400 24	(Soil coordinate points)
190 METH 1	(Analysis method)
200 WATR 95 64 .0625 1	(Water description)
210 2.813 5.492	(Water pressures on wedges)
220 3	
230 0 5.492	
240 134 3.764	
250 275 3.319	
260 2.5 3.319	
270 VPLO 50 40	(Vertical point/line load)
280 END	(Termination)

Precalculated seepage pressures are entered by first selecting the **1 = Defined by user** option for seepage, Item 4 on the Water Description screen (Figure B85). Then the **Define Seepage** button is selected in order to enter the pressure values as shown on Figure B86.

Water Description [X]

Uplift Force Print Help

Uplift force: Seepage Option

1. Left-side water elevation (ft): 95

2. Right-side water elevation (ft): 64

3. Unit weight of water (kcf): 0.0625

4. Seepage (-1, 0, 1): 1=Defined by user

Define Seepage

C:\CASE\RCSLIDE\X0075D4A.DAT is opened.

Ok Cancel

Figure B85. Defined by user seepage option selected, Problem 4A

Seepage (User Defined) [X]

Pressure Print Help

-> (1) Pressure on LEFT-side wedge (ksf) Enter values

4. Layer No.: 5. Pressure at top (ksf): 6. Pressure at bottom (ksf):

1 2.813 5.492

(1) Left-side : (2) Right-side : (3) Under structure:

Layer No.	(1) Pressure at top	(1) Pressure at bottom	(2) Pressure at top	(2) Pressure at bottom	Point No. (2 to 5)	(3) X-coord.	(3) Pressure
Layer 1	2.8130	5.4920	2.5000	3.3190	Point 1	0.0000	5.4920
Layer 2					Point 2	134.0000	3.7640
Layer 3					Point 3	275.0000	3.3190
Layer 4					Point 4		
Layer 5					Point 5		

Seepage option=1 (from water description) -> user defined

Ok Cancel

Figure B86. Input of seepage pressures, Problem 4A

Problem output

Factor of safety. Using the seepage pressures obtained from the flownet, a factor of safety value of 6.42 is obtained (Figure B87).

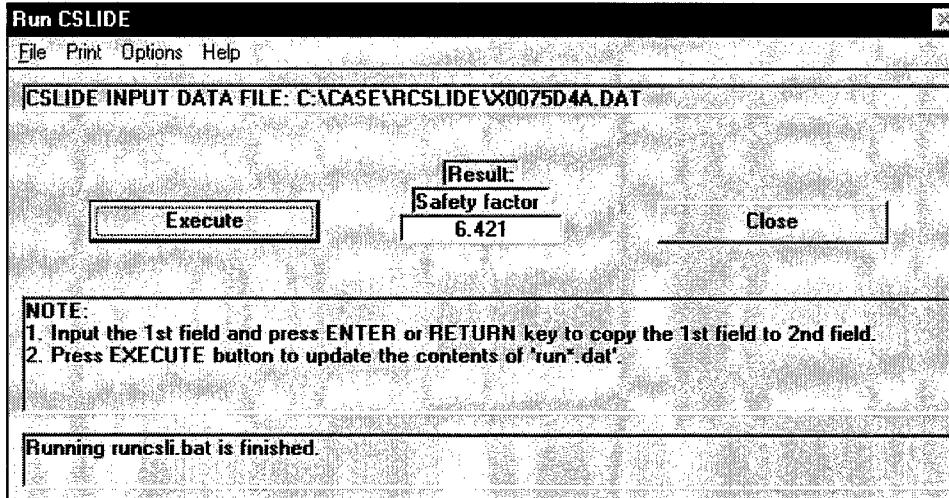

Figure B87. Factor of safety Problem 4A

Output file, X0075D4A.out

```
-----  
PROGRAM CSLIDE - ECHOPRINT  
-----  
  
DATE: 13-APR-1999                                TIME: 10.33.23  
  
DAM NO. 4 (PROB 4A)  
  
  
SINGLE FAILURE PLANE ANALYSIS  
  
SEEPAGE FORCE COMPUTED FROM INPUT PRESSURES.  
  
NO OF CORNERS IN STRUCTURE -----          10  
DENSITY OF CONCRETE -----          .1500 (KCF)  
DENSITY OF WATER -----          .0625 (KCF)  
WATER LEVEL LEFT SIDE -----          95.00 (FT)  
WATER LEVEL RIGHT SIDE -----          64.00 (FT)  
NO. OF SOIL LAYERS LEFT SIDE -----          1  
NO. OF SOIL LAYERS RIGHT SIDE -----          1
```

ELEV. OF WEDGE-STRUCTURE INTERSECTION
 ON ACTIVE SIDE OF STRUCTURE ----- .000 (FT)

STRUCTURE INFORMATION

POINT -----	X-COORD -----	Y-COORD -----
1	.00	.00
2	.00	8.50
3	20.00	50.00
4	20.00	110.00
5	72.00	110.00
6	72.00	95.00
7	134.00	95.00
8	134.00	24.00
9	275.00	24.00
10	275.00	14.00

LEFTSIDE SOIL DATA

LAYER NO.	FRICTION ANGLE (DEG)	COHESION (KSF)	UNIT WEIGHT (KCF)	ELEV AT STRUCTURE (FT)
1	30.00	.0000	.120	50.00

LAYER NO	POINT NO. 1 X-COORD	Y-COORD
1	-100.00	50.00

SOIL DATA BELOW STRUCTURE

FRICTION ANGLE ----- 30.00
 COHESION ----- .0000

RIGHTSIDE SOIL DATA

LAYER NO.	FRICTION ANGLE (DEG)	COHESION (KSF)	UNIT WEIGHT (KCF)	ELEV AT STRUCTURE (FT)
1	30.00	.0000	.120	24.00

LAYER NO	POINT NO. 1	
	X-COORD	Y-COORD
1	400.00	24.00

INPUT PRESSURES ON WEDGES

LEFTHAND WEDGES

WEDGE NO.	TOP PRESSURE (KSF)	BOTTOM PRESSURE (KSF)
1	2.813	5.492

STRUCTURAL WEDGE

X-COORD. (FT)	PRESSURE (KSF)
.00	5.492
134.00	3.764
275.00	3.319

RIGHTSIDE WEDGES

WEDGE NO.	TOP PRESSURE (KSF)	BOTTOM PRESSURE (KSF)
3	2.500	3.319

VERTICAL POINT LOADS

X-COORDINATE (FT)	MAGNITUDE (KIPS)
50.00	40.000

PROGRAM CSLIDE - FINAL RESULTS

DATE: 13-APR-1999

TIME: 10.33.23

DAM NO. 4 (PROB 4A)

SINGLE FAILURE PLANE ANALYSIS

SEEPAGE FORCE COMPUTED FROM INPUT PRESSURES

WEDGE NUMBER	HORIZONTAL LOADS		VERTICAL LOAD (KIPS)
	LEFT SIDE (KIPS)	RIGHT SIDE (KIPS)	
1	.000	.000	128.668
2	63.281	50.000	498.550
3	.000	.000	27.409

WATER PRESSURES ON WEDGES

LEFTSIDE WEDGES

WEDGE NO.	TOP PRESSURE (KSF)	BOTTOM PRESSURE (KSF)
1	2.813	5.492

STRUCTURAL WEDGE

X-COORD. (FT)	PRESSURE (KSF)
.00	5.492
134.00	3.764
275.00	3.319

RIGHTSIDE WEDGES

WEDGE NO.	TOP PRESSURE (KSF)	BOTTOM PRESSURE (KSF)
3	2.500	3.319

WEDGE NUMBER	FAILURE ANGLE (DEG)	TOTAL LENGTH (FT)	WEIGHT OF WEDGE (KIPS)	SUBMERGED LENGTH (FT)	UPLIFT FORCE (KIPS)
--------------	---------------------	-------------------	------------------------	-----------------------	---------------------

1	-47.542	67.771	137.246	67.771	81.420
2	2.914	275.356	2048.100	275.356	120.953
3	42.368	14.839	6.578	14.839	43.175

WEDGE NUMBER	NET FORCE ON WEDGE (KIPS)
--------------	---------------------------

1	-276.981
2	245.607
3	31.375

SUM OF FORCES ON SYSTEM ---- .000

FACTOR OF SAFETY ----- 6.421

Structure plot (Figure B88).

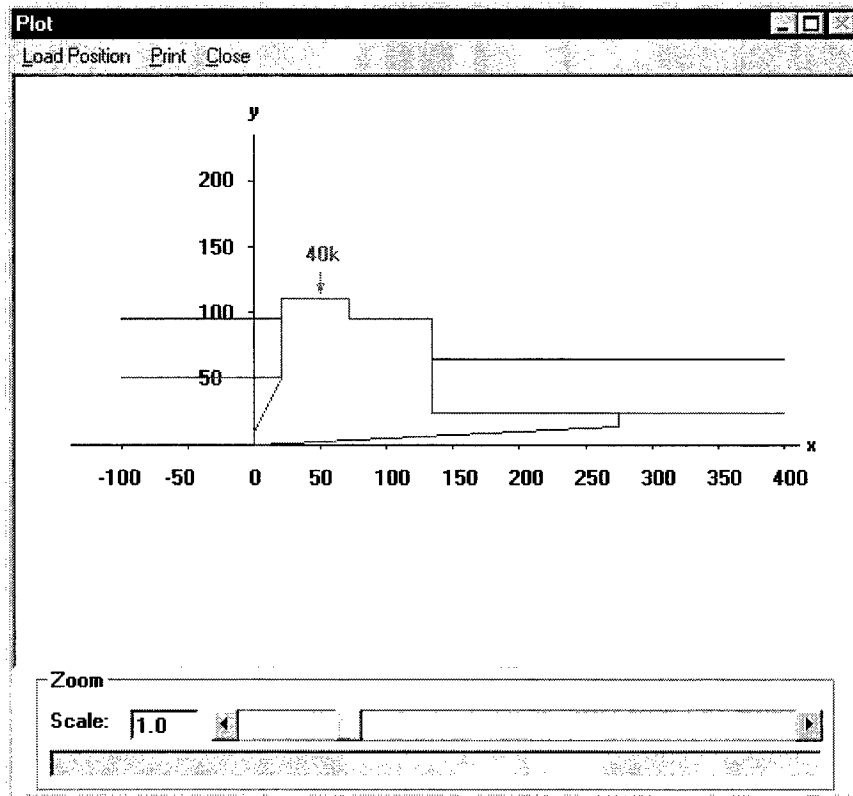

Figure B88. Structure plot – Problem 4A

Failure Surface plot (Figure B89).

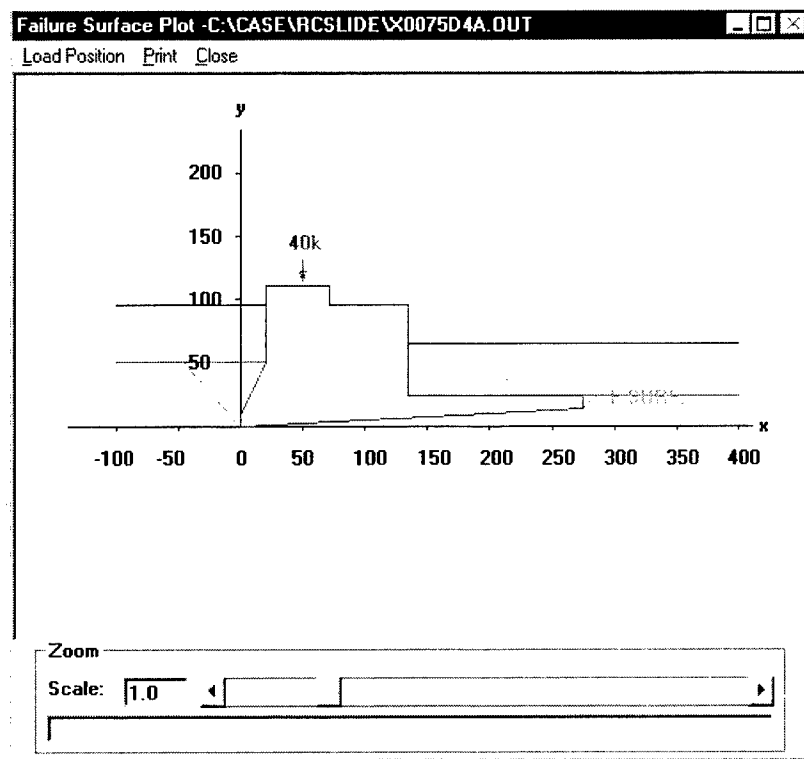

Figure B89. Failure Surface plot – Problem 4A

Wedge plots (Figures B90-B92).

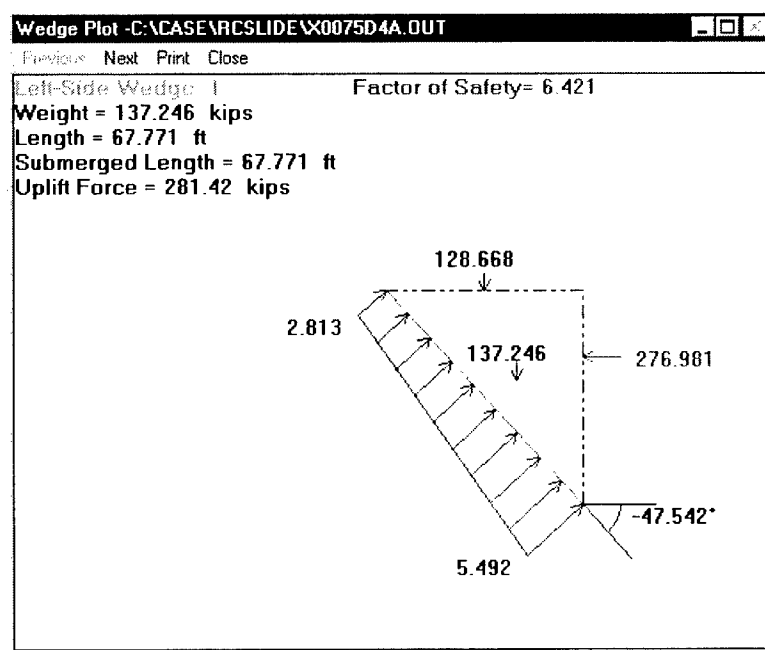

Figure B90. Left-side Wedge 1 Problem 4A

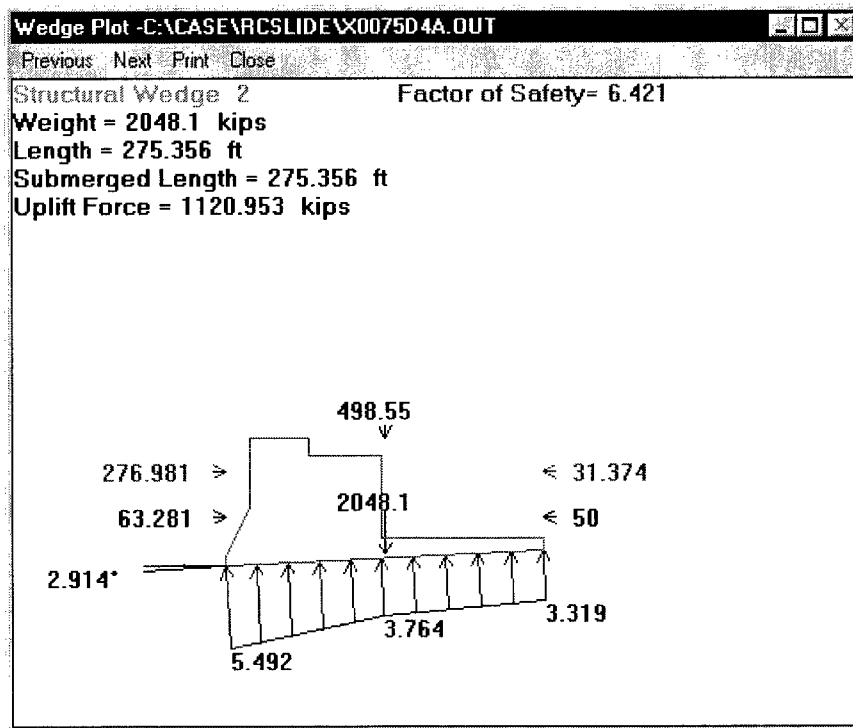

Figure B91. Structural Wedge 2 Problem 4A

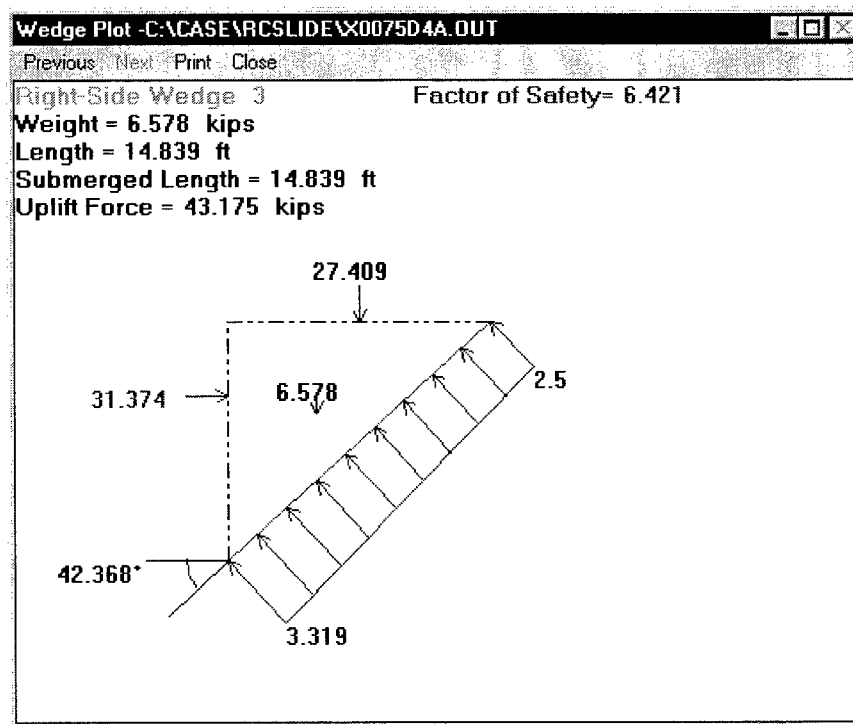

Figure B92. Right-side Wedge 3 Problem 4A

Problem 4B

Input file, X0075D4B.dat

```
00 TITL DAM NO. 4 (PROB 4B)
105 TITL LINE-OF-CREEP SEEPAGE
106 TITL
110 STRU 10 .15
120 0 0 0 8.5 20 50 20 110 72 110
130 72 95 134 95 134 24 275 24 275 14
140 SOLT 1 1 30 0 .12 50
150 -100 50
160 SOST 30 0
170 SORT 1 1 30 0 .12 24
180 400 24
190 METH 1
200 WATR 95 64 .0625 -1
210 VPLO 50 40
220 END
```

For Part B of Problem 4, the **-1 = line-of-creep** option calculating seepage pressure is selected on the **Water Description** screen (Figure B93).

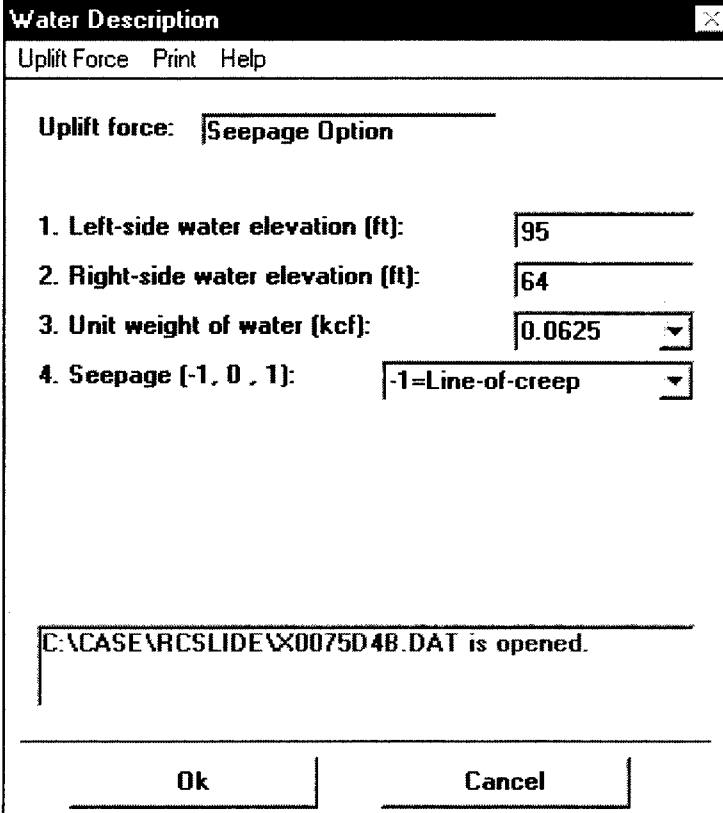

The screenshot shows a dialog box titled "Water Description" with a menu bar containing "Uplift Force", "Print", and "Help". The main area contains the following fields:

- Uplift force:** Seepage Option
- 1. Left-side water elevation (ft):** 95
- 2. Right-side water elevation (ft):** 64
- 3. Unit weight of water (kcf):** 0.0625
- 4. Seepage [-1, 0, 1]:** -1=Line-of-creep

At the bottom, a status bar displays the message: "C:\CASE\RCSLIDE\X0075D4B.DAT is opened." Below the status bar are "Ok" and "Cancel" buttons.

Figure B93. Seepage calculation using line-of-creep method

Problem output

Factor of safety. The factor of safety obtained from using water pressures calculated by the line-of-creep method of analysis in CSLIDE is given in Figure B94.

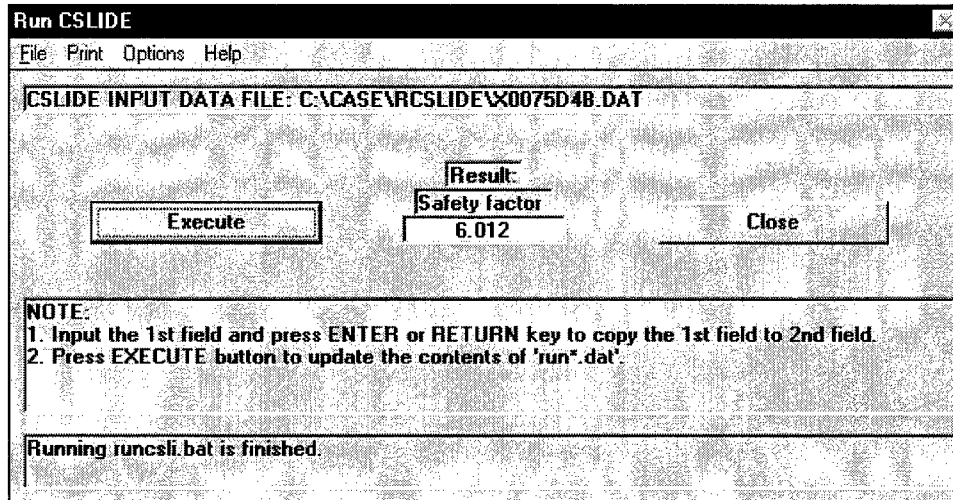

Figure B94. Factor of safety Problem 4B

Output file, X0075D4B.out

```
-----  
PROGRAM CSLIDE - ECHOPRINT  
-----  
  
DATE: 13-APR-1999                      TIME: 10.36.15  
  
DAM NO. 4 (PROB 4B)  
LINE-OF-CREEP SEEPAGE  
  
SINGLE FAILURE PLANE ANALYSIS  
  
SEEPAGE FORCE BY LINE OF CREEP, GRADIENT  
COMPUTED USING SHORTEST SEEPAGE PATH.  
  
NO OF CORNERS IN STRUCTURE ----- 10  
DENSITY OF CONCRETE ----- .1500 (KCF)  
DENSITY OF WATER ----- .0625 (KCF)  
WATER LEVEL LEFT SIDE ----- 95.00 (FT)  
WATER LEVEL RIGHT SIDE ----- 64.00 (FT)  
NO. OF SOIL LAYERS LEFT SIDE ----- 1  
NO. OF SOIL LAYERS RIGHT SIDE ----- 1
```

ELEV. OF WEDGE-STRUCTURE INTERSECTION
 ON ACTIVE SIDE OF STRUCTURE ----- .000 (FT)

STRUCTURE INFORMATION

POINT -----	X-COORD -----	Y-COORD -----
1	.00	.00
2	.00	8.50
3	20.00	50.00
4	20.00	110.00
5	72.00	110.00
6	72.00	95.00
7	134.00	95.00
8	134.00	24.00
9	275.00	24.00
10	275.00	14.00

LEFT-SIDE SOIL DATA

LAYER NO.	FRICTION ANGLE (DEG)	COHESION (KSF)	UNIT WEIGHT (KCF)	ELEV AT STRUCTURE (FT)

1	30.00	.0000	.120	50.00

LAYER NO.	POINT NO. 1 X-COORD	Y-COORD
1	-100.00	50.00

SOIL DATA BELOW STRUCTURE

FRICTION ANGLE ----- 30.00
 COHESION ----- .0000

RIGHT-SIDE SOIL DATA

LAYER NO.	FRICTION ANGLE (DEG)	COHESION (KSF)	UNIT WEIGHT (KCF)	ELEV AT STRUCTURE (FT)

1	30.00	.0000	.120	24.00

LAYER NO	POINT NO. 1 X-COORD Y-COORD	
1	400.00	24.00

VERTICAL POINT LOADS

X-COORDINATE (FT)	MAGNITUDE (KIPS)
50.00	40.000

PROGRAM CSLIDE - FINAL RESULTS

DATE: 13-APR-1999

TIME: 10.36.15

DAM NO. 4 (PROB 4B)

LINE-OF-CREEP SEEPAGE

SINGLE FAILURE PLANE ANALYSIS

SEEPAGE FORCE COMPUTED BY LINE OF CREEP

WEDGE NUMBER	HORIZONTAL LOADS		VERTICAL LOAD (KIPS)
	LEFT SIDE (KIPS)	RIGHT SIDE (KIPS)	
1	.000	.000	127.905
2	63.281	50.000	498.550
3	.000	.000	27.789

WATER PRESSURES ON WEDGES

LEFT-SIDE WEDGES

WEDGE NO.	TOP PRESSURE (KSF)	BOTTOM PRESSURE (KSF)
1	2.813	5.649

STRUCTURAL WEDGE

X-COORD. (FT)	PRESSURE (KSF)
.00	5.649
275.00	3.183

RIGHT-SIDE WEDGES

WEDGE NO.	TOP PRESSURE (KSF)	BOTTOM PRESSURE (KSF)
3	2.500	3.183

WEDGE NUMBER	FAILURE ANGLE (DEG)	TOTAL LENGTH (FT)	WEIGHT OF WEDGE (KIPS)	SUBMERGED LENGTH (FT)	UPLIFT FORCE (KIPS)
1	-47.712	67.588	136.432	67.588	285.937
2	2.914	275.356	2048.100	275.356	1215.891
3	41.976	14.952	6.669	14.952	42.484

WEDGE NUMBER NET FORCE ON WEDGE
(KIPS)

1	-276.822
2	245.276
3	31.547

SUM OF FORCES ON SYSTEM ---- .000
 FACTOR OF SAFETY ----- 6.012

Failure Surface plot (Figure B95).

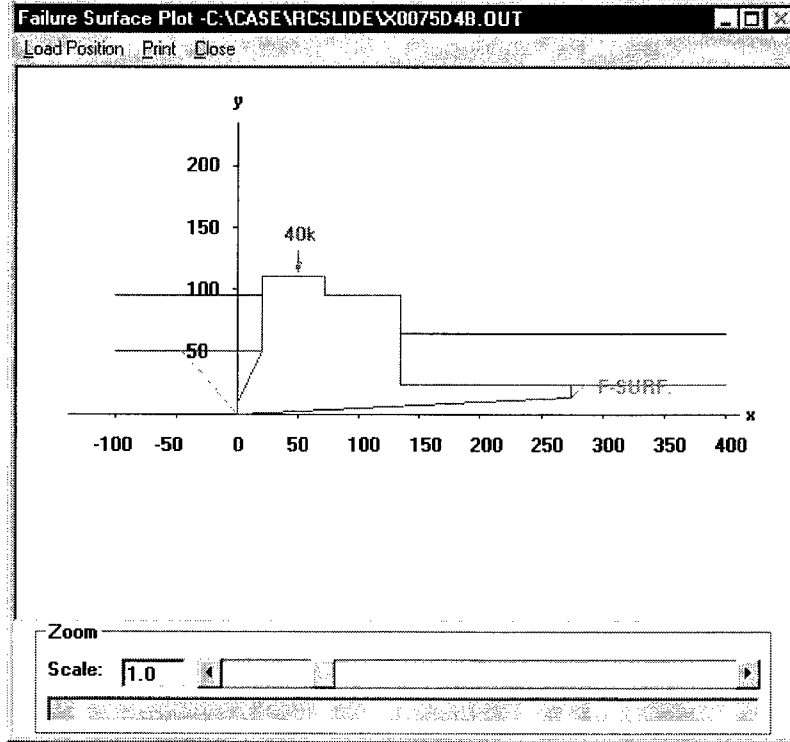

Figure B95. Failure Surface plot – Problem 4B

Wedge plots (Figures B96-B98).

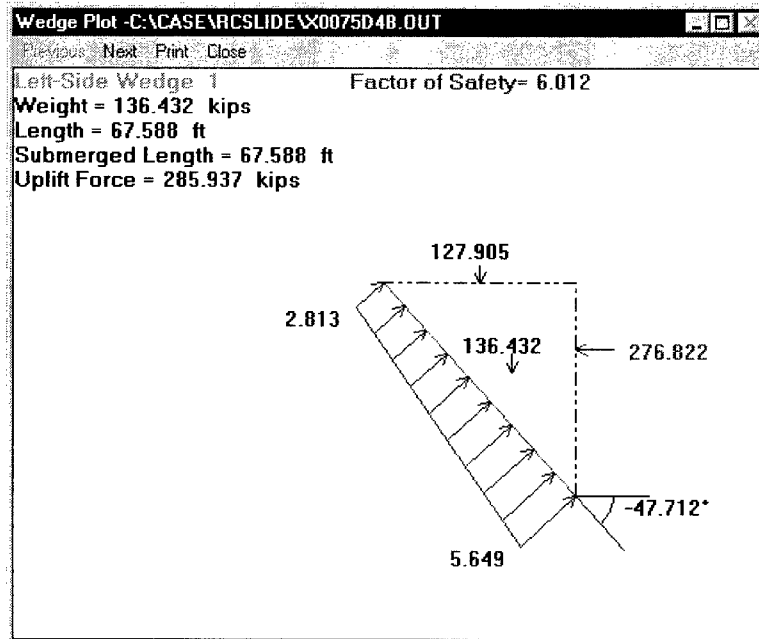

Figure B96. Left-side Wedge 1 Problem 4B

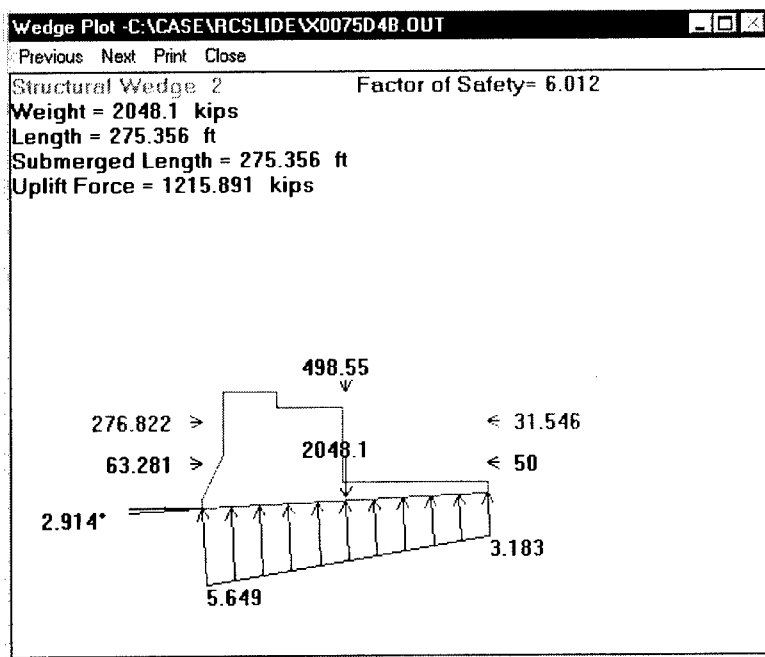

Figure B97. Structural Wedge 2 Problem 4B

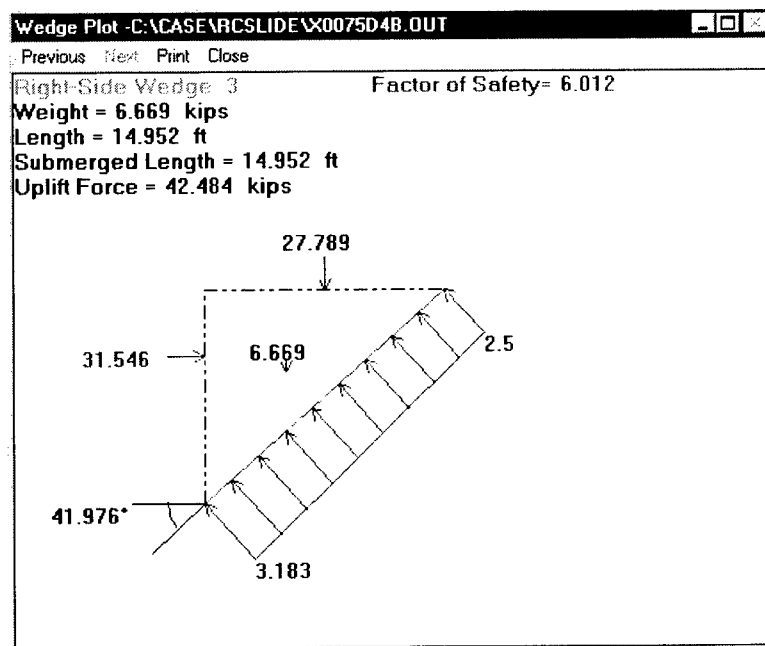

Figure B98. Right-side Wedge 3 Problem 4B

Problem 4C

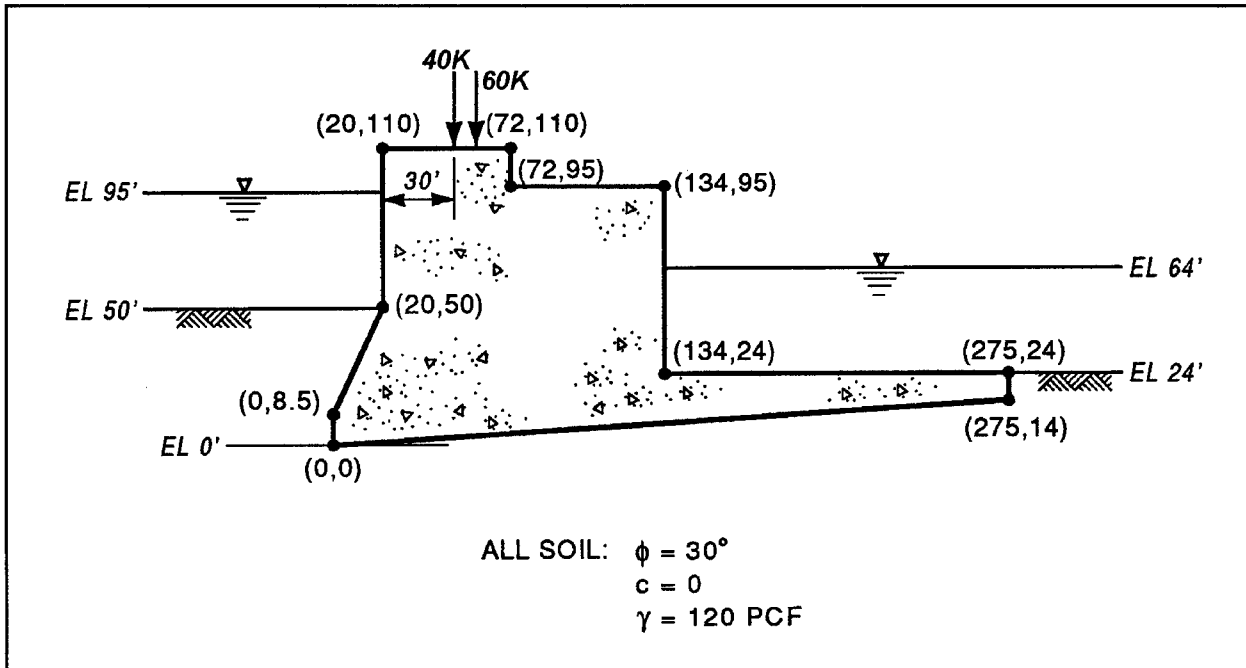

Figure B99. Dam No. 4 with an anchor force

Input file, Listing Problem 4C

```

100 TITL DAM NO. 4 with an anchor (PROB 4C)
105 TITL LINE-OF-CREEP SEEPAGE
106 TITL
110 STRU 10 .15
120 0 0 8.5 20 50 20 110 72 110
130 72 95 134 95 134 24 275 24 275 14
140 SOLT 1 1 30 0 .12 50
150 -100 50
160 SOST 30 0
170 SORT 1 1 30 0 .12 24
180 400 24
190 METH 1
200 WATR 95 64 .0625 -1
210 VPLO 50 40
220 ANCH 60 0
230 END

```

Anchors

Print Help

Enter values for up to three (3) anchors:

	Force (kips/ft) :	Angle (degrees from vertical) :
Anchor 1 :	60	0
Anchor 2 :	0	0
Anchor 3 :	0	0

Ok Cancel

Figure B100. Anchor window

Problem output

Factor of safety. The factor of safety obtained when a 60-kip anchor force is added to the dam is presented in Figure B101.

Run CSLIDE

File Print Options Help

CSLIDE INPUT DATA FILE: C:\CASE\RCSLIDE\X0075D4C.DAT

Execute	Result: Safety factor 6.393	Close
---------	-----------------------------------	-------

NOTE:
 1. Input the 1st field and press ENTER or RETURN key to copy the 1st field to 2nd field.
 2. Press EXECUTE button to update the contents of 'run*.dat'.

Running runcsli.bat is finished.

Figure B101. Factor of safety Problem 4C

Output file, X0075D4C.out

PROGRAM CSLIDE - ECHOPRINT

DATE: 15-JUN-2000

TIME: 10.37.02

DAM NO. 4 WITH AN ANCHOR (PROB 4C)

LINE-OF-CREEP SEEPAGE

SINGLE FAILURE PLANE ANALYSIS

SEEPAGE FORCE BY LINE OF CREEP, GRADIENT
COMPUTED USING SHORTEST SEEPAGE PATH.

NO OF CORNERS IN STRUCTURE -----	10
DENSITY OF CONCRETE -----	.1500 (KCF)
DENSITY OF WATER -----	.0625 (KCF)
WATER LEVEL LEFT SIDE -----	95.00 (FT)
WATER LEVEL RIGHT SIDE -----	64.00 (FT)
NO. OF SOIL LAYERS LEFT SIDE -----	1
NO. OF SOIL LAYERS RIGHT SIDE -----	1

ELEV. OF WEDGE-STRUCTURE INTERSECTION ON ACTIVE SIDE OF STRUCTURE -----	.000 (FT)
--	-----------

STRUCTURE INFORMATION

POINT -----	X-COORD -----	Y-COORD -----
1	.00	.00
2	.00	8.50
3	20.00	50.00
4	20.00	110.00
5	72.00	110.00
6	72.00	95.00
7	134.00	95.00
8	134.00	24.00
9	275.00	24.00
10	275.00	14.00

LEFT-SIDE SOIL DATA

LAYER NO.	FRICTION ANGLE (DEG)	COHESION (KSF)	UNIT WEIGHT (KCF)	ELEV AT STRUCTURE (FT)
1	30.00	.0000	.120	50.00

LAYER NO	POINT NO. 1 X-COORD	Y-COORD
1	-100.00	50.00

SOIL DATA BELOW STRUCTURE

FRICTION ANGLE ----- 30.00
 COHESION ----- .0000

RIGHT-SIDE SOIL DATA

LAYER NO.	FRICTION ANGLE (DEG)	COHESION (KSF)	UNIT WEIGHT (KCF)	ELEV AT STRUCTURE (FT)
1	30.00	.0000	.120	24.00

LAYER NO	POINT NO. 1 X-COORD	Y-COORD
1	400.00	24.00

ANCHOR INFORMATION

FORCE KIPS/FT	ANGLE (DEG)
60.00	.00

VERTICAL POINT LOADS

X-COORDINATE (FT)	MAGNITUDE (KIPS)
50.00	40.000

PROGRAM CSLIDE - FINAL RESULTS

DATE: 15-JUN-2000

TIME: 10.37.02

DAM NO. 4 WITH AN ANCHOR (PROB 4C)

LINE-OF-CREEP SEEPAGE

SINGLE FAILURE PLANE ANALYSIS

SEEPAGE FORCE COMPUTED BY LINE OF CREEP

WEDGE NUMBER	HORIZONTAL LOADS		VERTICAL LOAD (KIPS)
	LEFT SIDE (KIPS)	RIGHT SIDE (KIPS)	
1	.000	.000	128.495
2	63.281	50.000	558.550
3	.000	.000	27.588

WATER PRESSURES ON WEDGES

LEFT-SIDE WEDGES

WEDGE NO.	TOP PRESSURE (KSF)	BOTTOM PRESSURE (KSF)
1	2.813	5.649

STRUCTURAL WEDGE

X-COORD. (FT)	PRESSURE (KSF)
.00	5.649
275.00	3.183

RIGHT-SIDE WEDGES

WEDGE NO. TOP PRESSURE BOTTOM PRESSURE
(KSF) (KSF)

3 2.500 3.183

WEDGE FAILURE TOTAL WEIGHT SUBMERGED UPLIFT
NUMBER ANGLE LENGTH OF WEDGE LENGTH FORCE
(DEG) (FT) (KIPS) (FT) (KIPS)

1 -47.581 67.730 137.061 67.730 286.535
2 2.914 275.356 2048.100 275.356 1215.891
3 42.182 14.892 6.621 14.892 42.314

WEDGE NET FORCE
NUMBER ON WEDGE
(KIPS)

1 -277.572
2 246.061
3 31.511

SUM OF FORCES ON SYSTEM ---- .000

FACTOR OF SAFETY ----- 6.393

Failure Surface plot (Figure B102).

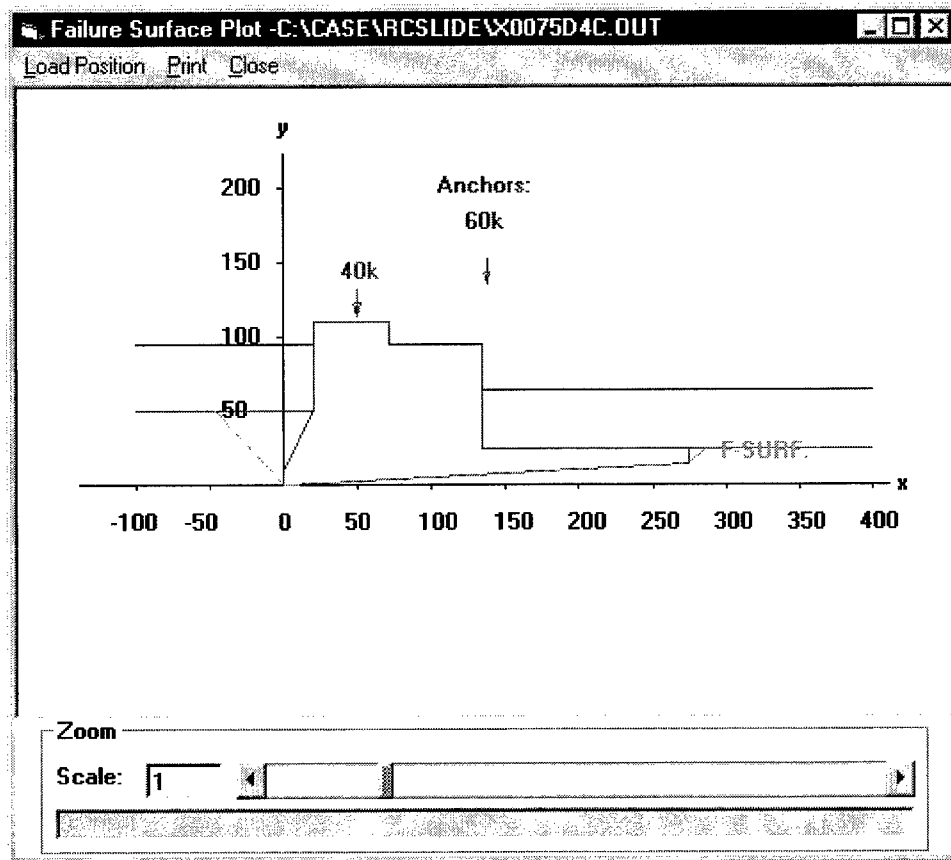

Figure B102. Failure Surface plot – Problem 4C

Wedge plots (Figures B103-B105).

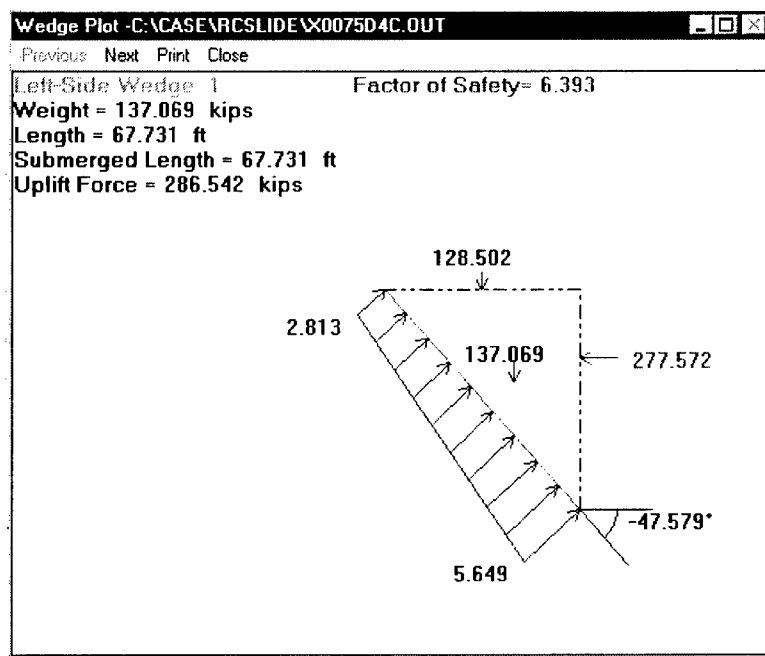

Figure B103. Left-side Wedge 1 Problem 4C

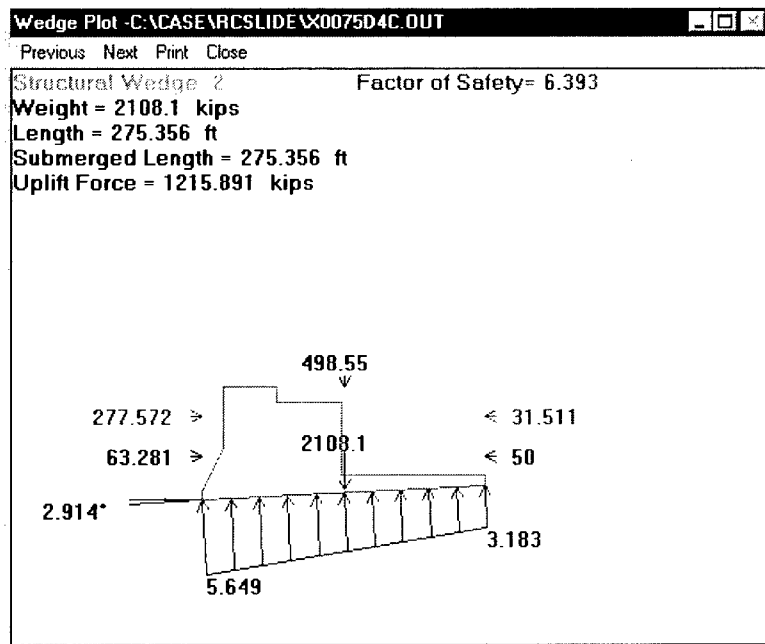

Figure B104. Structural Wedge 2 Problem 4C

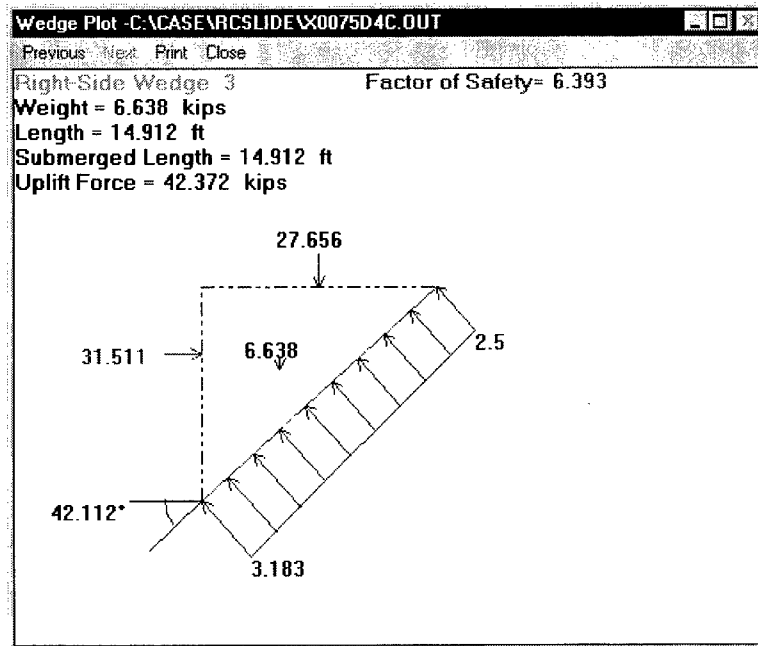

Figure B105. Right-side Wedge 3 Problem 4C

Problem 5

The purpose of this example is to demonstrate how to determine the net forces corresponding to a specific safety factor using CSLIDE. The **Safety Factor** option on the **Edit** menu allows the user to enter the upper and lower limit, which determines the safety factors used in the first two iterations of the solution process. If the safety factor is entered for both of these values, CSLIDE produces results for this desired safety factor only. Unless this safety factor happens to be the actual one that produces equilibrium conditions, the sum of the net forces on the wedges will not be zero. If this net force sum is a positive number, the actual safety factor is greater than the value entered; but if the sum is negative, the actual safety factor is less than the one entered. In this example, a specific safety factor is input and results are obtained. The original default values are used in a second analysis, and the solution converges to the actual safety factor at which equilibrium occurs.

Part A. Find the net forces on the system shown in Figure B106 using a sliding safety factor of 1.5.

Part B. Find the actual safety factor of this system in equilibrium conditions.

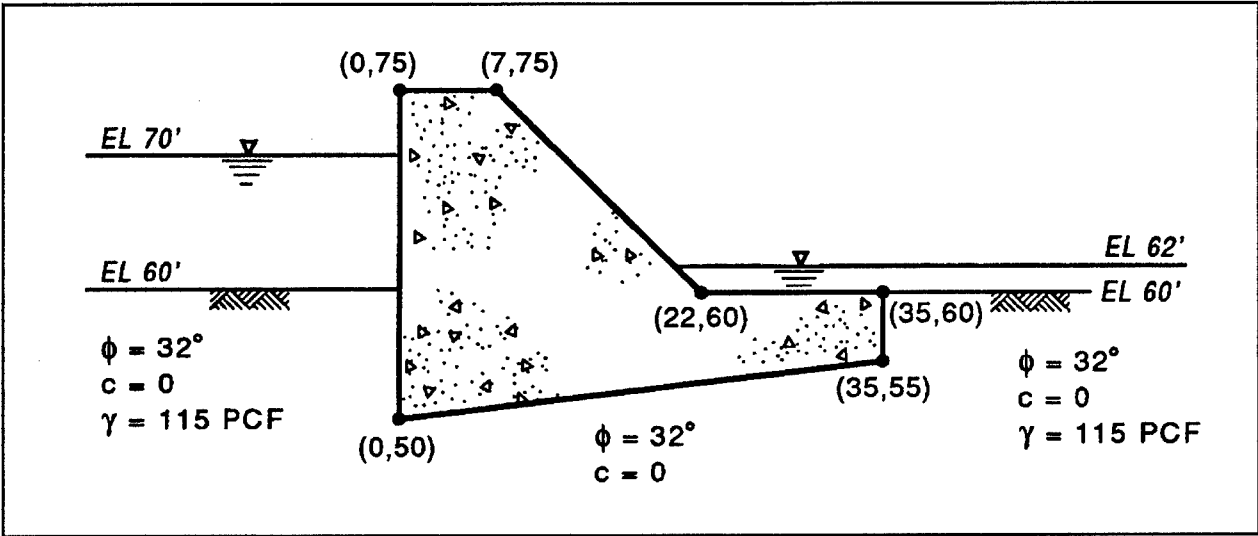

Figure B106. Structure and soil for Problem 5

Problem 5A

Input file, X0075D5A.dat

```
100 TITL CSLIDE #5A (Title)
110 STRU 6 .15000 50.00 1.00000 (Structural information)
120 .00 50.00 (Structure coordinates)
130 .00 75.00
140 7.00 75.00
150 22.00 60.00
160 35.00 60.00
170 35.00 55.00
180 SOLT 1 1 32.00 .00000 .11500 60.00 (Left-side soil layer description)
190 -100.00 60.00 (Soil layer coordinates)
200 SOST 32 0 (Soil below the structure)
210 SORT 1 1 32.00 .00000 .11500 60.00 (Right-side soil layer description)
220 150.00 60.00 (Soil layer coordinates)
230 WATR 70.00 62.00 .06250 -1. (Water description)
240 METH 1 (Analysis method)
250 FACT 1.50 1.50 1.0000 (Safety factor)
260 END (Termination)
```

CSLIDE produces results for the safety factor of 1.5 when it is entered as both the lower and upper limit as shown in Figure B107.

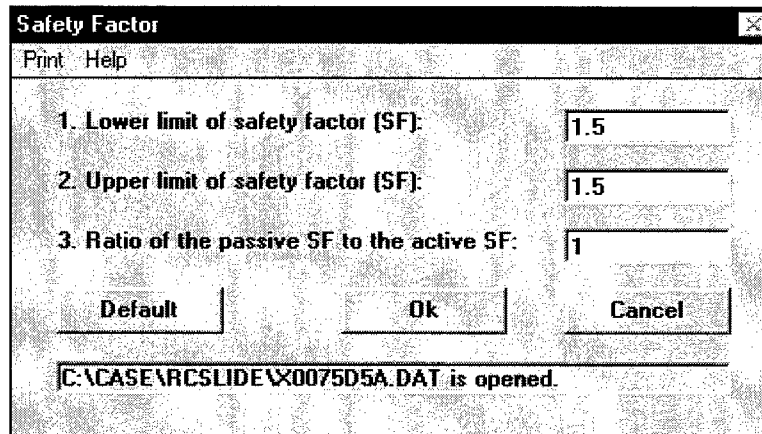

Figure B107. Safety factor window

Problem output

Factor of safety. A resultant factor of safety of 1.5 (see Figure B108) is achieved as specified in the problem input.

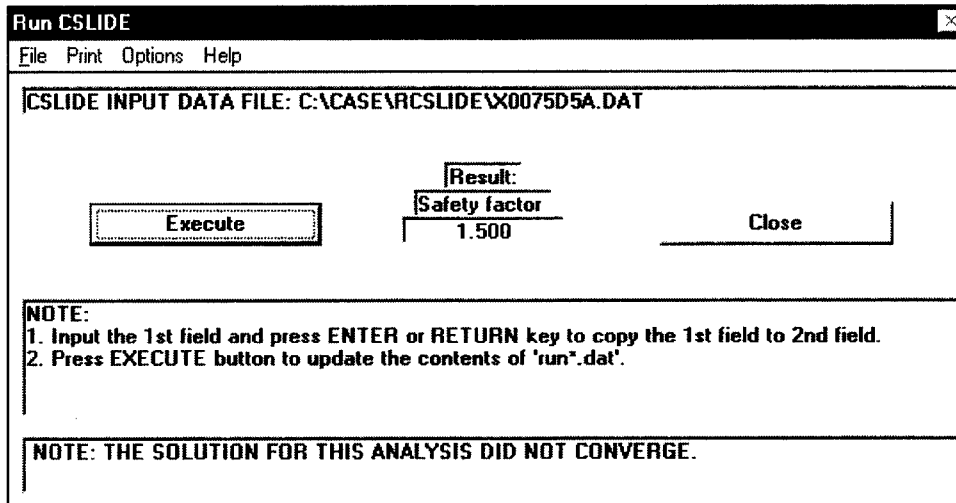

Figure B108. Factor of safety Problem 5

Output file, X0075D5A.out

In this analysis, equilibrium was not achieved because of the unbalanced net force on the system. Therefore, the label “Stationary Solution” appears in the output, rather than the usual “Final Results,” to indicate this condition. Below are the results of the stationary solution for Problem 5A. The positive sum of the forces, 20.376, indicates that the actual safety factor is greater than 1.5.

```

-----
PROGRAM CSLIDE - ECHOPRINT
-----

DATE: 13-APR-1999                                TIME: 10.39.19

CSLIDE #5A

SINGLE FAILURE PLANE ANALYSIS

SEEPAGE FORCE BY LINE OF CREEP, GRADIENT
COMPUTED USING SHORTEST SEEPAGE PATH.

NO OF CORNERS IN STRUCTURE -----                6
DENSITY OF CONCRETE -----                .1500 (KCF)
DENSITY OF WATER -----                .0625 (KCF)
WATER LEVEL LEFT SIDE -----                70.00 (FT)
WATER LEVEL RIGHT SIDE -----                62.00 (FT)
NO. OF SOIL LAYERS LEFT SIDE -----                1
NO. OF SOIL LAYERS RIGHT SIDE -----                1

```

ELEV. OF WEDGE-STRUCTURE INTERSECTION
 ON ACTIVE SIDE OF STRUCTURE ----- 50.000(FT)

STRUCTURE INFORMATION

POINT -----	X-COORD -----	Y-COORD -----
1	.00	50.00
2	.00	75.00
3	7.00	75.00
4	22.00	60.00
5	35.00	60.00
6	35.00	55.00

LEFT-SIDE SOIL DATA

LAYER NO.	FRICTION ANGLE (DEG)	COHESION (KSF)	UNIT WEIGHT (KCF)	ELEV AT STRUCTURE (FT)
1	32.00	.0000	.115	60.00

LAYER NO	POINT NO. 1 X-COORD	Y-COORD
1	-100.00	60.00

SOIL DATA BELOW STRUCTURE

FRICTION ANGLE ----- 32.00
 COHESION ----- .0000

RIGHT-SIDE SOIL DATA

LAYER NO.	FRICTION ANGLE (DEG)	COHESION (KSF)	UNIT WEIGHT (KCF)	ELEV AT STRUCTURE (FT)
1	32.00	.0000	.115	60.00

LAYER NO	POINT NO. 1 X-COORD	Y-COORD
1	150.00	60.00

SAFETY FACTOR DESCRIPTION

 LOWER LIMIT OF F.S. ----- 1.50
 UPPER LIMIT OF F.S. ----- 1.50

 STATIONARY SOLUTION

DATE: 13-APR-1999

TIME: 10.39.19

CSLIDE #5A

SINGLE FAILURE PLANE ANALYSIS

SEEPAGE FORCE COMPUTED BY LINE OF CREEP

WEDGE NUMBER	HORIZONTAL LOADS		VERTICAL LOAD (KIPS)
	LEFT SIDE (KIPS)	RIGHT SIDE (KIPS)	
1	.000	.000	4.165
2	3.125	.125	1.750
3	.000	.000	.937

 WATER PRESSURES ON WEDGES

 LEFT-SIDE WEDGES

WEDGE NO.	TOP PRESSURE (KSF)	BOTTOM PRESSURE (KSF)
1	.625	1.151

 STRUCTURAL WEDGE

X-COORD. (FT)	PRESSURE (KSF)
.00	1.151
35.00	.487

RIGHT-SIDE WEDGES

WEDGE NO.	TOP PRESSURE (KSF)	BOTTOM PRESSURE (KSF)
3	.125	.487

WEDGE NUMBER	FAILURE ANGLE (DEG)	TOTAL LENGTH (FT)	WEIGHT OF WEDGE (KIPS)	SUBMERGED LENGTH (FT)	UPLIFT FORCE (KIPS)
1	-56.320	12.017	3.832	12.017	10.669
2	8.130	35.355	72.000	35.355	28.953
3	33.714	9.008	2.154	9.008	2.757

WEDGE NUMBER	NET FORCE ON WEDGE (KIPS)
--------------	------------------------------

1	-10.266
2	27.914
3	2.727

SUM OF FORCES ON SYSTEM ---- 20.376

FACTOR OF SAFETY ----- 1.500

* NOTE * THE SOLUTION HAS NOT CONVERGED.

Problem 5B

Input file, X0075D5B.dat

```

001 TITL CSLIDE #5B
002 TITL
003 TITL
004 TITL
005 STRU 6 .15000 50.00 1.00000
006 0.00 50.00
007 0.00 75.00
008 7.00 75.00
009 22.00 60.00
010 35.00 60.00
011 35.00 55.00
012 SOLT 1 1 32.00 .00000 .11500 60.00
013 -100.00 60.00
014 SORT 1 1 32.00 .00000 .11500 60.00
015 150.00 60.00
    
```

```

016 SOST 32.00 .00000
017 METH 1
018 WATR 70.00 62.00 .06250
019 FACT 0.5000 1.5000 1.0000
020 END

```

The actual factor of safety under equilibrium conditions is determined by changing the safety factor iteration limits to the original (default) values of 0.5 and 1.5. This can be accomplished by selecting the **Default** button on the Safety Factor window (see Figure B109).

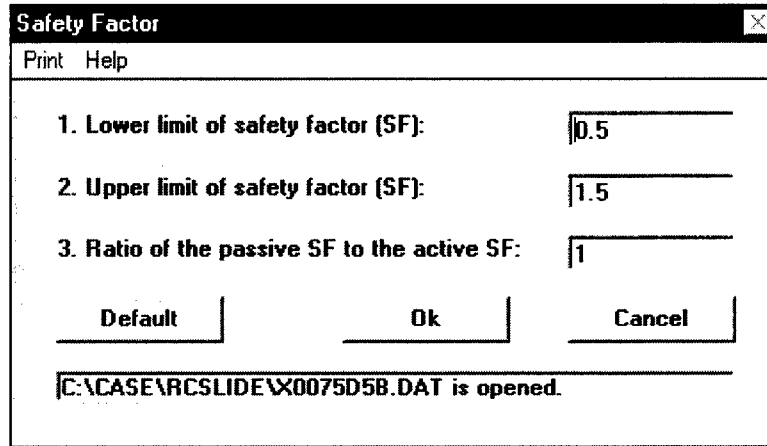

Figure B109. Safety factor window with default values selected

Problem output

Factor of safety. The solution converges with an actual factor of safety for equilibrium conditions of 13.887 as shown in Figure B110. As determined in Problem 5A, this value is greater than the selected value of 1.5.

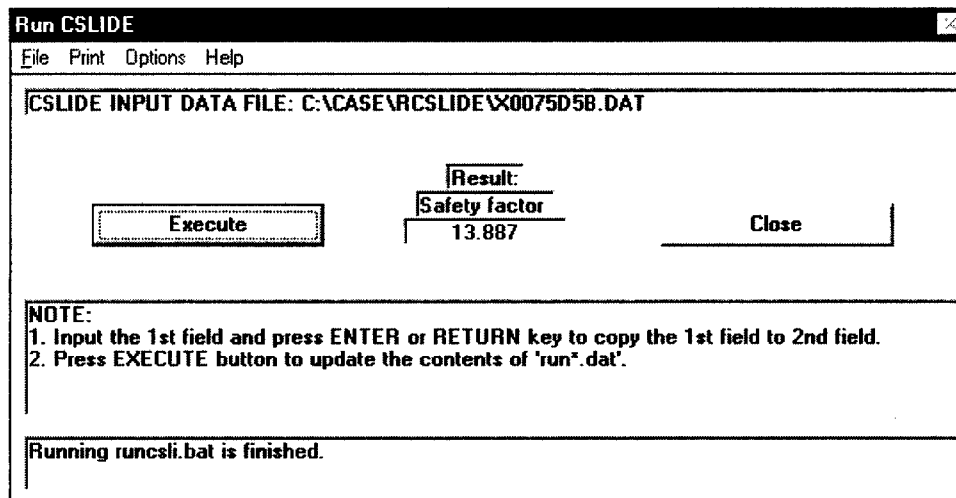

Figure B110. Factor of safety Problem 5B

Output file, X0075D5B.out

PROGRAM CSLIDE - ECHOPRINT

DATE: 13-APR-1999

TIME: 10.41.21

CSLIDE #5B

SINGLE FAILURE PLANE ANALYSIS

SEEPAGE FORCE BY LINE OF CREEP, GRADIENT
COMPUTED USING SHORTEST SEEPAGE PATH.

NO OF CORNERS IN STRUCTURE -----	6
DENSITY OF CONCRETE -----	.1500 (KCF)
DENSITY OF WATER -----	.0625 (KCF)
WATER LEVEL LEFT SIDE -----	70.00 (FT)
WATER LEVEL RIGHT SIDE -----	62.00 (FT)
NO. OF SOIL LAYERS LEFT SIDE -----	1
NO. OF SOIL LAYERS RIGHT SIDE -----	1

ELEV. OF WEDGE-STRUCTURE INTERSECTION
ON ACTIVE SIDE OF STRUCTURE ----- 50.000 (FT)

STRUCTURE INFORMATION

POINT -----	X-COORD -----	Y-COORD -----
1	.00	50.00
2	.00	75.00
3	7.00	75.00
4	22.00	60.00
5	35.00	60.00
6	35.00	55.00

LEFT-SIDE SOIL DATA

LAYER NO.	FRICTION ANGLE (DEG)	COHESION (KSF)	UNIT WEIGHT (KCF)	ELEV AT STRUCTURE (FT)
1	32.00	.0000	.115	60.00

LAYER NO	POINT NO. 1 X-COORD	Y-COORD
1	-100.00	60.00

SOIL DATA BELOW STRUCTURE

 FRICTION ANGLE ----- 32.00
 COHESION ----- .0000

RIGHT-SIDE SOIL DATA

LAYER NO.	FRICTION ANGLE (DEG)	COHESION (KSF)	UNIT WEIGHT (KCF)	ELEV AT STRUCTURE (FT)
1	32.00	.0000	.115	60.00

LAYER NO	POINT NO. 1 X-COORD	Y-COORD
1	150.00	60.00

 PROGRAM CSLIDE - FINAL RESULTS

DATE: 13-APR-1999

TIME: 10.41.21

CSLIDE #5B

SINGLE FAILURE PLANE ANALYSIS

SEEPAGE FORCE COMPUTED BY LINE OF CREEP

WEDGE NUMBER	HORIZONTAL LOADS		VERTICAL LOAD (KIPS)
	LEFT SIDE (KIPS)	RIGHT SIDE (KIPS)	
1	.000	.000	5.969
2	3.125	.125	1.750
3	.000	.000	.651

WATER PRESSURES ON WEDGES

LEFT-SIDE WEDGES

WEDGE NO.	TOP PRESSURE (KSF)	BOTTOM PRESSURE (KSF)
1	.625	1.151

STRUCTURAL WEDGE

X-COORD. (FT)	PRESSURE (KSF)
.00	1.151
35.00	.487

RIGHT-SIDE WEDGES

WEDGE NO.	TOP PRESSURE (KSF)	BOTTOM PRESSURE (KSF)
3	.125	.487

WEDGE NUMBER	FAILURE ANGLE (DEG)	TOTAL LENGTH (FT)	WEIGHT OF WEDGE (KIPS)	SUBMERGED LENGTH (FT)	UPLIFT FORCE (KIPS)
1	-46.315	13.828	5.492	13.828	12.278
2	8.130	35.355	72.000	35.355	28.953
3	43.818	7.222	1.498	7.222	2.210

WEDGE NUMBER NET FORCE ON WEDGE
(KIPS)

1	-11.731
2	9.619
3	2.113

SUM OF FORCES ON SYSTEM ---- .000
 FACTOR OF SAFETY ----- 13.887

Structure plot (Figure B111).

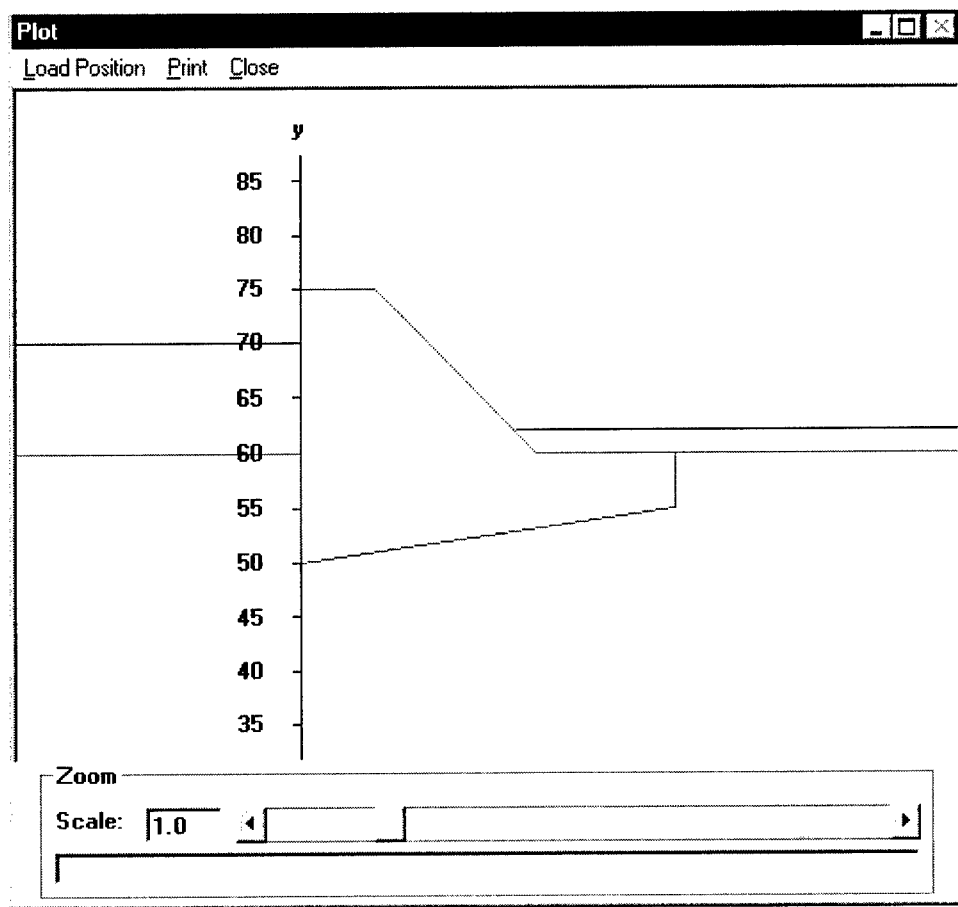

Figure B111. Structure plot – Problem 5B

Failure Surface plot (Figure B112).

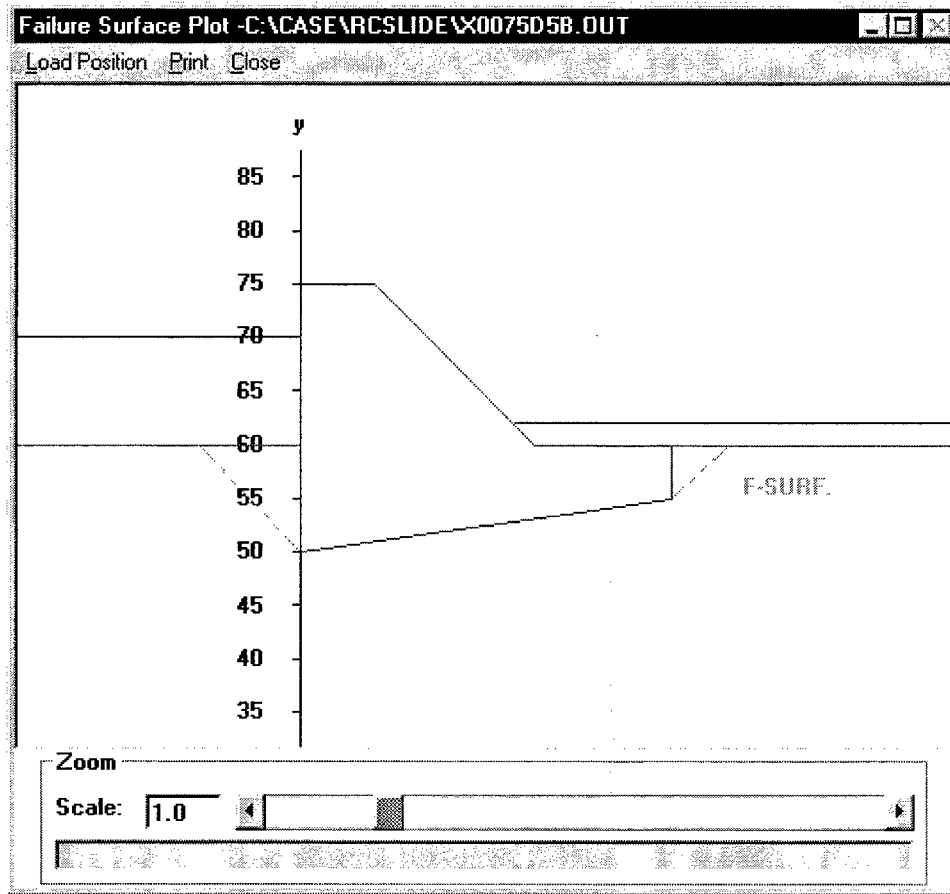

Figure B112. Failure Surface plot – Problem 5B

Problem 6

This example problem demonstrates how to reduce the passive forces in a CSLIDE analysis. In cases where full passive resistance does not develop, one would reduce or exclude the passive forces in the sliding analysis. The retaining wall system in this example (Figure B113) is such a case. An option in CSLIDE called the passive-to-active safety-factor ratio is used to increase the passive safety factor, with respect to the active safety factor, thereby reducing passive soil resistance.

First an equilibrium analysis is performed to determine the equilibrium safety factor. Then the full passive resistance for this system can be obtained from the results when the safety factor is one. The value of this fully developed passive force is required in order to determine how much it is actually reduced in subsequent analyses. A third analysis is run using a passive-to-active ratio of 4.0 to reduce the passive resistance.

Part A. Find the equilibrium safety factor for the wall in Figure B113.

Part B. Set the safety factor to 1.0 to find the full passive force value.

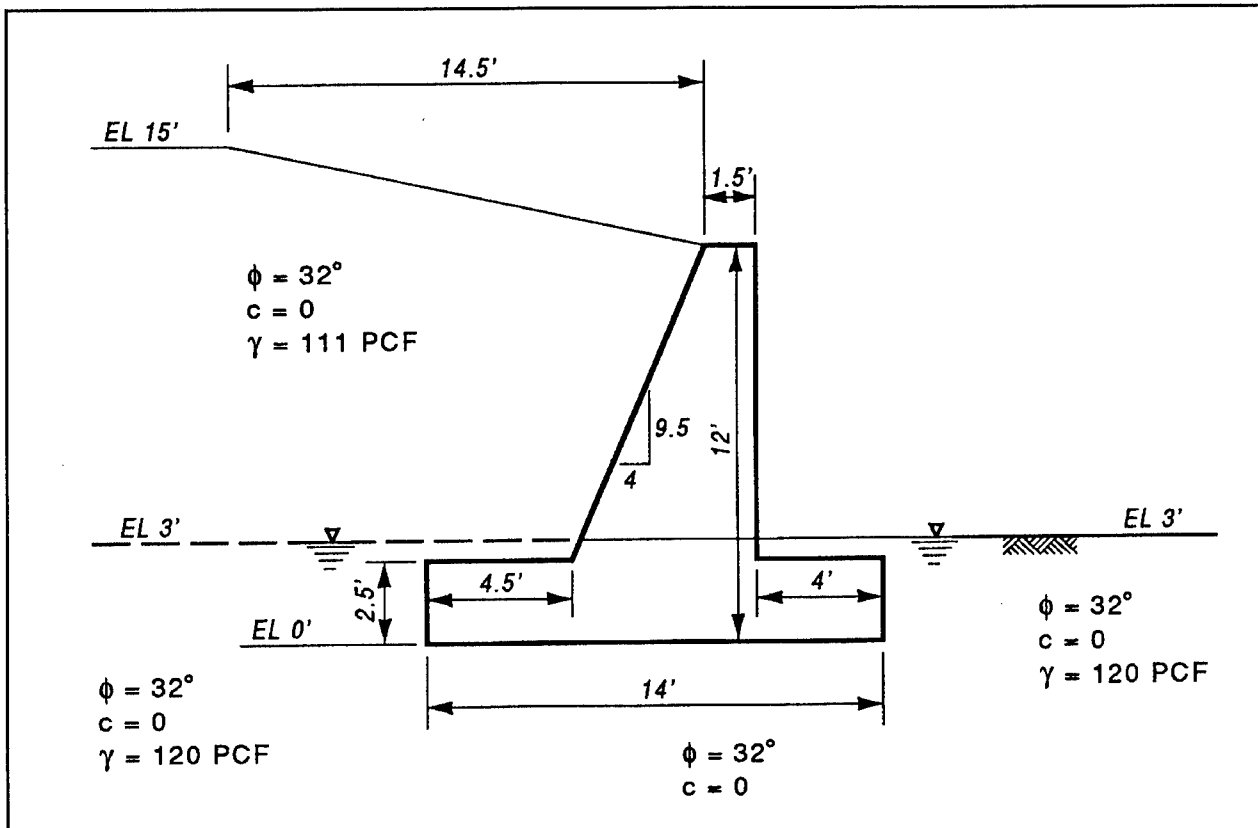

Figure B113. Structure and soil Problem 6

Part C. Run a third analysis using a safety factor ratio of 4.0 ($FS_{\text{passive}} = 4$, $FS_{\text{active}} = 1$), and compare the net forces from both analyses.

Problem 6A

Input file, X0075D6A.dat

```

100 TITL RETAINING WALL - CHECK FS RATIO 6A (Title)
110 TITL FSP/FSA = 1.0
120 STRU 8 .15000 .00 1.00000 (Structural information)
130 .00 .00 (Structure coordinates)
140 .00 2.50
150 4.50 2.50
160 8.50 12.00
170 10.00 12.00
180 10.00 2.50
190 14.00 2.50
200 14.00 .00
210 SOLT 1 2 32.00 .00000 .11100 12.00 (Left-side Soil Layer 1 description)
220 -500.00 15.00 (Soil layer coordinates)
230 -6.00 15.00
240 SOLT 2 1 32.00 .00000 .12000 3.00 (Left-side Soil Layer 2 description)
250 -500.00 3.00 (Soil layer coordinates)
260 SOST 32 0 (Soil below the structure)
270 SORT 1 1 32.00 .00000 .12000 3.00 (Right-side soil layer description)
280 500.00 3.00 (Soil layer coordinates)
290 WATR 3.00 3.00 .06250 0. (Water description)
300 METH 1 (Analysis method)
305 FACT 0.5000 1.500 1.0000 (Factor of safety)
310 END (Termination)

```

Problem output

Factor of safety. Final results compute a factor of safety value of approximately 1.8 (Figure B114).

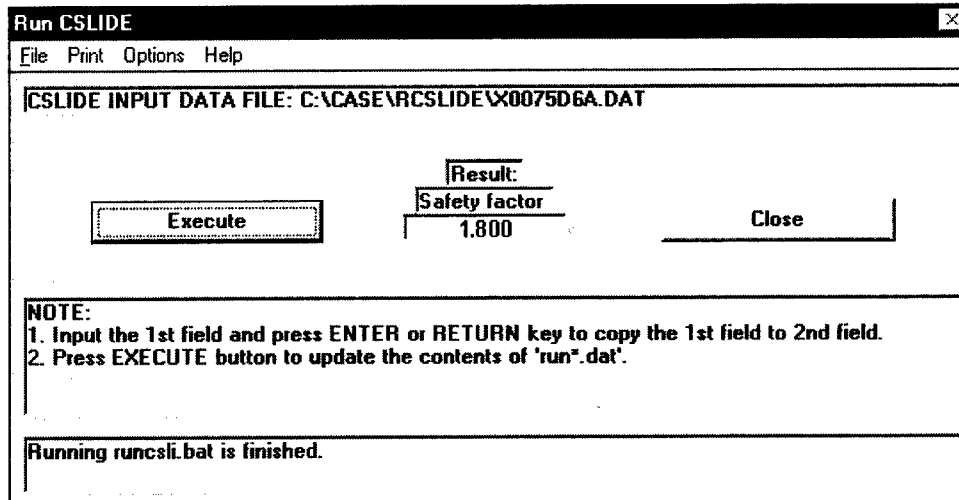

Figure B114. Factor of safety Problem 6A

Output file, X0075D6A.out

```

-----
PROGRAM CSLIDE - ECHOPRINT
-----

DATE: 13-APR-1999                TIME: 10.44.12

RETAINING WALL - CHECK FS RATIO 6A

FSP/FSA = 1.0

SINGLE FAILURE PLANE ANALYSIS

HYDROSTATIC WATER FORCE COMPUTED FOR WEDGES

NO OF CORNERS IN STRUCTURE ----- 8
DENSITY OF CONCRETE ----- .1500 (KCF)
DENSITY OF WATER ----- .0625 (KCF)
WATER LEVEL LEFT SIDE ----- 3.00 (FT)
WATER LEVEL RIGHT SIDE ----- 3.00 (FT)
NO. OF SOIL LAYERS LEFT SIDE ----- 2
NO. OF SOIL LAYERS RIGHT SIDE ----- 1

ELEV. OF WEDGE-STRUCTURE INTERSECTION
ON ACTIVE SIDE OF STRUCTURE ----- .000 (FT)

```

STRUCTURE INFORMATION

POINT	X-COORD	Y-COORD
1	.00	.00
2	.00	2.50
3	4.50	2.50
4	8.50	12.00
5	10.00	12.00
6	10.00	2.50
7	14.00	2.50
8	14.00	.00

LEFT-SIDE SOIL DATA

LAYER NO.	FRICTION ANGLE (DEG)	COHESION (KSF)	UNIT WEIGHT (KCF)	ELEV AT STRUCTURE (FT)
1	32.00	.0000	.111	12.00
2	32.00	.0000	.120	3.00

LAYER NO	POINT NO. 1 X-COORD	POINT NO. 1 Y-COORD	POINT NO. 2 X-COORD	POINT NO. 2 Y-COORD
1	-500.00	15.00	-6.00	15.00
2	-500.00	3.00	*****	*****

SOIL DATA BELOW STRUCTURE

FRICTION ANGLE ----- 32.00
 COHESION ----- .0000

RIGHT-SIDE SOIL DATA

LAYER NO.	FRICTION ANGLE (DEG)	COHESION (KSF)	UNIT WEIGHT (KCF)	ELEV AT STRUCTURE (FT)
1	32.00	.0000	.120	3.00

LAYER NO	POINT NO. 1 X-COORD	POINT NO. 1 Y-COORD
1	500.00	3.00

PROGRAM CSLIDE - FINAL RESULTS

DATE: 13-APR-1999

TIME: 10.44.12

RETAINING WALL - CHECK FS RATIO 6A

FSP/FSA = 1.0

SINGLE FAILURE PLANE ANALYSIS

HYDROSTATIC WATER FORCE COMPUTED FOR WEDGES

WEDGE NUMBER	HORIZONTAL LOADS		VERTICAL LOAD (KIPS)
	LEFT SIDE (KIPS)	RIGHT SIDE (KIPS)	
1	.000	.000	.000
2	.000	.000	.000
3	.000	.000	7.945
4	.000	.000	.000

WATER PRESSURES ON WEDGES

LEFT-SIDE WEDGES

WEDGE NO.	TOP PRESSURE (KSF)	BOTTOM PRESSURE (KSF)
1	.000	.000
2	.000	.188

STRUCTURAL WEDGE

X-COORD. (FT)	PRESSURE (KSF)
.00	.188
14.00	.188

RIGHT-SIDE WEDGES

WEDGE NO.	TOP PRESSURE (KSF)	BOTTOM PRESSURE (KSF)
-----------	-----------------------	--------------------------

4	.000	.188
---	------	------

WEDGE NUMBER	FAILURE ANGLE (DEG)	TOTAL LENGTH (FT)	WEIGHT OF WEDGE (KIPS)	SUBMERGED LENGTH (FT)	UPLIFT FORCE (KIPS)
-----------------	---------------------------	-------------------------	------------------------------	-----------------------------	---------------------------

1	-52.696	15.086	5.931	.000	.000
2	-52.696	3.772	3.201	3.772	.354
3	.000	14.000	10.238	14.000	2.625
4	35.402	5.179	.760	5.179	.485

WEDGE NUMBER	NET FORCE ON WEDGE (KIPS)
-----------------	---------------------------------

1	-3.933
2	-2.262
3	5.402
4	.793

SUM OF FORCES ON SYSTEM ---- .000

FACTOR OF SAFETY ----- 1.800

Structure plot (Figure B115).

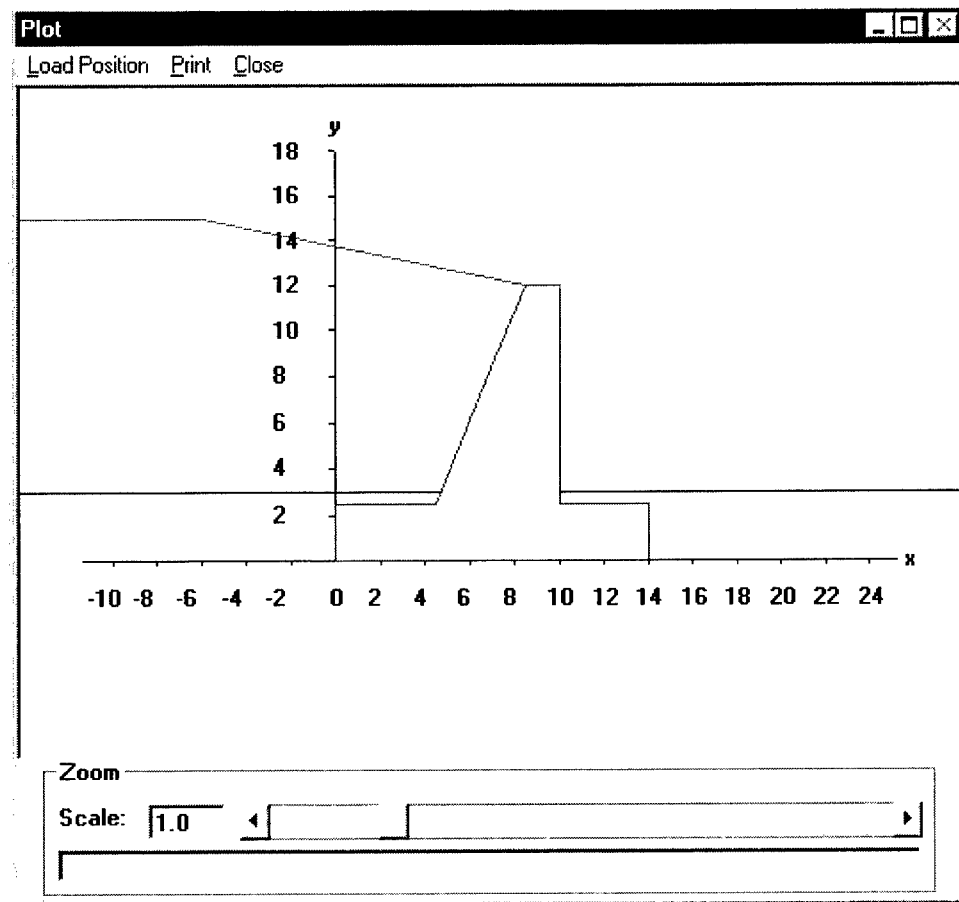

Figure B115 Structure plot – Problem 6A

Failure Surface plot (Figure B116).

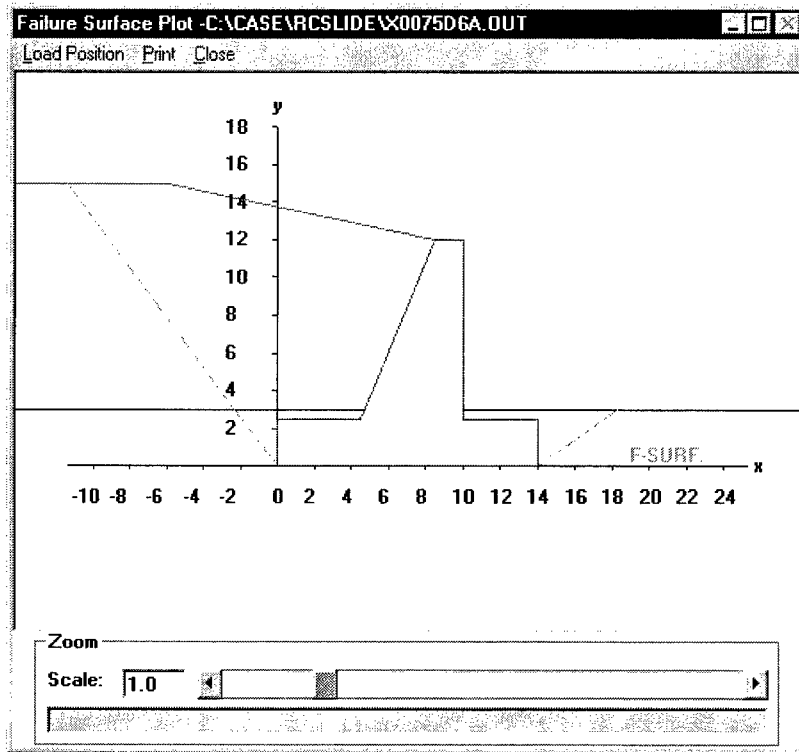

Figure B116. Failure Surface plot – Problem 6A

Wedge plots (Figures B117-B120).

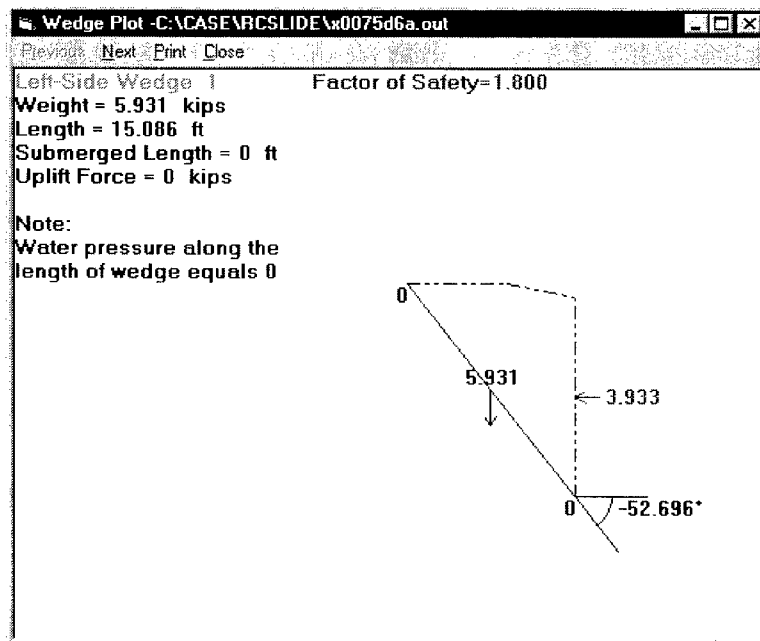

Figure B117. Left-side Wedge 1 Problem 6A

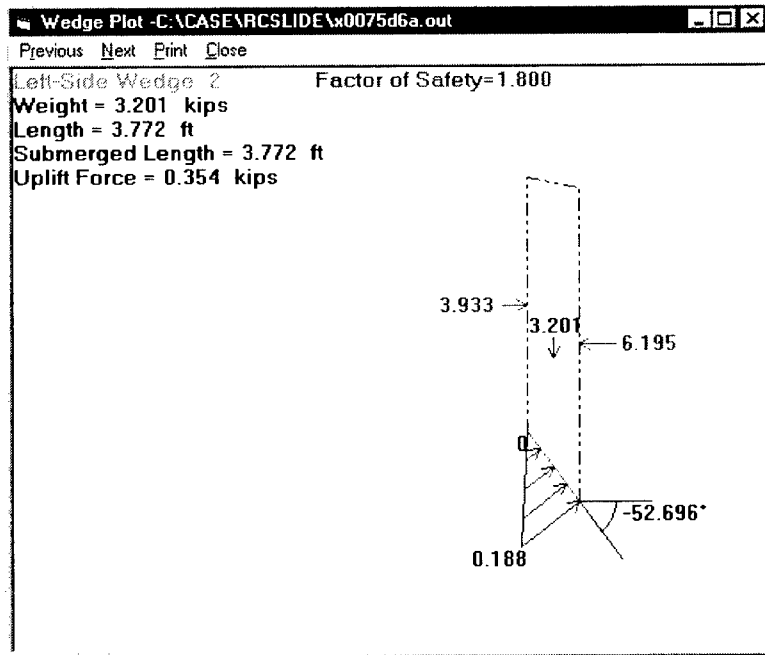

Figure B118. Left-side Wedge 2 Problem 6A

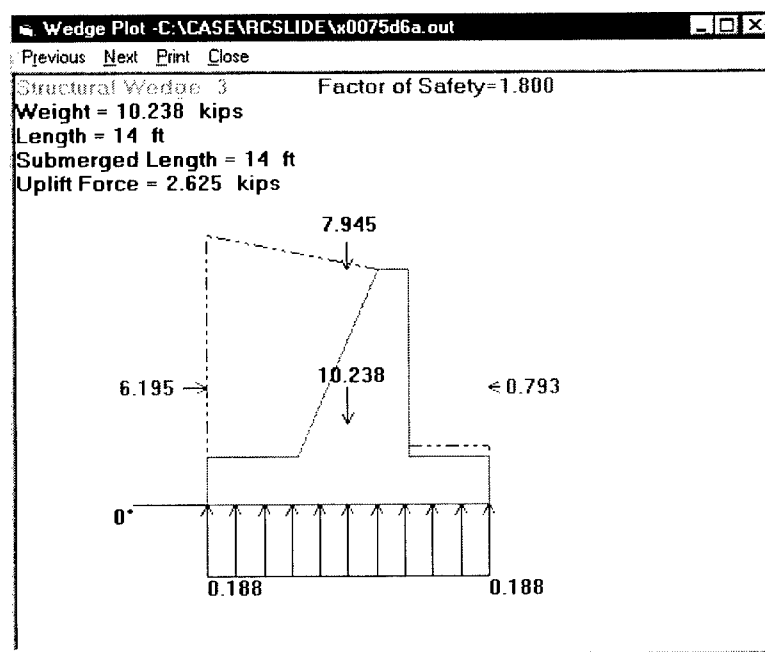

Figure B119. Structural Wedge 3 Problem 6A

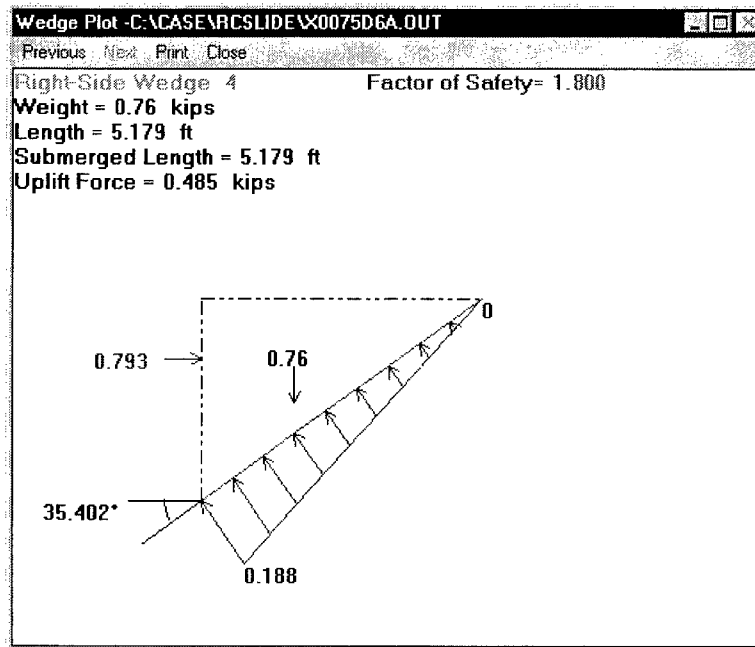

Figure B120. Right-side Wedge 4 Problem 6A

Problem 6B

Input file, X0075D6B.dat

```

100 TITL RETAINING WALL - CHECK FS RATIO 6B
110 TITL FSP/FSA = 1.0
120 STRU 8 .15000 .00 1.00000
130 .00 .00
140 .00 2.50
150 4.50 2.50
160 8.50 12.00
170 10.00 12.00
180 10.00 2.50
190 14.00 2.50
200 14.00 .00
210 SOLT 1 2 32.00 .00000 .11100 12.00
220 -500.00 15.00
230 -6.00 15.00
240 SOLT 2 1 32.00 .00000 .12000 3.00
250 -500.00 3.00
260 SOST 32 0
270 SORT 1 1 32.00 .00000 .12000 3.00
280 500.00 3.00
290 WATR 3.00 3.00 .06250 0.
300 METH 1
305 FACT 1.0000 1.000 1.0000
310 END

```

Data from Problem 6A is edited to require a safety factor of 1.0 by setting the upper and lower limits to 1.0 on the Safety Factor window (Figure B121).

Safety Factor

Print Help

1. Lower limit of safety factor (SF): 1

2. Upper limit of safety factor (SF): 1

3. Ratio of the passive SF to the active SF: 1

Default Ok Cancel

C:\CASE\RCSLIDE\X0075D6B.DAT is opened.

Figure B121. Safety factor window

Problem Output

The specified value of 1.0 for the safety factor is obtained as shown in Figure B122. In this stationary solution, equilibrium was not achieved because of the unbalanced net force on the system. But the results can be used to determine the full passive force value.

Run CSLIDE

File Print Options Help

CSLIDE INPUT DATA FILE: C:\CASE\RCSLIDE\X0075D6B.DAT

Execute	Result: Safety factor 1.000000	Close
---------	--------------------------------------	-------

NOTE:
1. Input the 1st field and press ENTER or RETURN key to copy the 1st field to 2nd field.
2. Press EXECUTE button to update the contents of 'run*.dat'.

NOTE: THE SOLUTION FOR THIS ANALYSIS DID NOT CONVERGE.

Figure B122. Factor of safety

Output file, X0075D6B.out

PROGRAM CSLIDE - ECHOPRINT

DATE: 13-APR-1999

TIME: 10.48.12

RETAINING WALL - CHECK FS RATIO 6B

FSP/FSA = 1.0

SINGLE FAILURE PLANE ANALYSIS

HYDROSTATIC WATER FORCE COMPUTED FOR WEDGES

NO OF CORNERS IN STRUCTURE -----	8
DENSITY OF CONCRETE -----	.1500 (KCF)
DENSITY OF WATER -----	.0625 (KCF)
WATER LEVEL LEFT SIDE -----	3.00 (FT)
WATER LEVEL RIGHT SIDE -----	3.00 (FT)
NO. OF SOIL LAYERS LEFT SIDE -----	2
NO. OF SOIL LAYERS RIGHT SIDE -----	1

ELEV. OF WEDGE-STRUCTURE INTERSECTION ON ACTIVE SIDE OF STRUCTURE -----	.000 (FT)
--	-----------

STRUCTURE INFORMATION

POINT -----	X-COORD -----	Y-COORD -----
1	.00	.00
2	.00	2.50
3	4.50	2.50
4	8.50	12.00
5	10.00	12.00
6	10.00	2.50
7	14.00	2.50
8	14.00	.00

LEFT-SIDE SOIL DATA

LAYER NO.	FRICTION ANGLE (DEG)	COHESION (KSF)	UNIT WEIGHT (KCF)	ELEV AT STRUCTURE (FT)

1	32.00	.0000	.111	12.00
2	32.00	.0000	.120	3.00

LAYER NO	POINT NO. 1		POINT NO. 2	
	X-COORD	Y-COORD	X-COORD	Y-COORD
1	-500.00	15.00	-6.00	15.00
2	-500.00	3.00	*****	*****

SOIL DATA BELOW STRUCTURE

FRICITION ANGLE ----- 32.00
COHESION ----- .0000

RIGHT-SIDE SOIL DATA

LAYER NO.	FRICITION ANGLE (DEG)	COHESION (KSF)	UNIT WEIGHT (KCF)	ELEV AT STRUCTURE (FT)
1	32.00	.0000	.120	3.00

LAYER NO	POINT NO. 1	
	X-COORD	Y-COORD
1	500.00	3.00

SAFETY FACTOR DESCRIPTION

LOWER LIMIT OF F.S. ----- 1.00
UPPER LIMIT OF F.S. ----- 1.00

STATIONARY SOLUTION

DATE: 13-APR-1999

TIME: 10.48.12

RETAINING WALL - CHECK FS RATIO 6B

FSP/FSA = 1.0

SINGLE FAILURE PLANE ANALYSIS

HYDROSTATIC WATER FORCE COMPUTED FOR WEDGES

WEDGE NUMBER	HORIZONTAL LOADS		VERTICAL LOAD (KIPS)
	LEFT SIDE (KIPS)	RIGHT SIDE (KIPS)	
1	.000	.000	.000
2	.000	.000	.000
3	.000	.000	7.945
4	.000	.000	.000

WATER PRESSURES ON WEDGES

LEFT-SIDE WEDGES

WEDGE NO.	TOP PRESSURE (KSF)	BOTTOM PRESSURE (KSF)
1	.000	.000
2	.000	.188

STRUCTURAL WEDGE

X-COORD. (FT)	PRESSURE (KSF)
.00	.188
14.00	.188

RIGHT-SIDE WEDGES

WEDGE NO.	TOP PRESSURE (KSF)	BOTTOM PRESSURE (KSF)
4	.000	.188

WEDGE NUMBER	FAILURE ANGLE (DEG)	TOTAL LENGTH (FT)	WEIGHT OF WEDGE (KIPS)	SUBMERGED LENGTH (FT)	UPLIFT FORCE (KIPS)
1	-59.640	13.907	4.475	.000	.000
2	-59.640	3.477	2.450	3.477	.326
3	.000	14.000	10.238	14.000	2.625
4	28.992	6.190	.975	6.190	.580

WEDGE NUMBER	NET FORCE ON WEDGE (KIPS)
1	-2.343
2	-1.478
3	9.721
4	1.123

SUM OF FORCES ON SYSTEM ----	7.023
FACTOR OF SAFETY -----	1.000

• NOTE * THE SOLUTION HAS NOT CONVERGED.

Problem 6C

Input file, X0075D6C.dat

```

001 TITL RETAINING WALL - CHECK FS RATIO 6C
002 TITL FSP/FSA = 4.0
003 TITL
004 TITL
005 STRU 8 .15000 0.00 1.00000
006 0.00 0.00
007 0.00 2.50
008 4.50 2.50
009 8.50 12.00
010 10.00 12.00
011 10.00 2.50
012 14.00 2.50
013 14.00 0.00
014 SOLT 1 2 32.00 .00000 .11100 12.00
015 -500.00 15.00
016 -6.00 15.00
017 SOLT 2 1 32.00 .00000 .12000 3.00
018 -500.00 3.00
019 SORT 1 1 32.00 .00000 .12000 3.00
020 500.00 3.00
021 SOST 32.00 0.00000
022 METH 1
023 WATR 3.00 3.00 .06250 0
024 FACT 0.5000 1.5000 4.0000
025 END

```

For the second analysis, the data from Problem 6A is edited to change the factor of safety ratio of 4.0 by changing the ratio (Field 3) on the Safety Factor window (Figure B123).

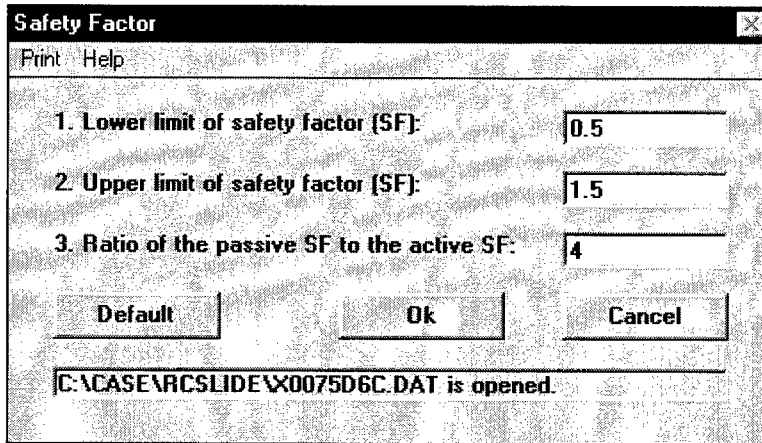

Figure B123. Safety factor window

Problem output

Factor of safety. The factor of safety, 1.761, obtained from the CSLIDE analysis (Figure B124), is for the active side and the structural wedge only. Therefore, the passive side has a factor of safety of $1.761(4) = 7.044$.

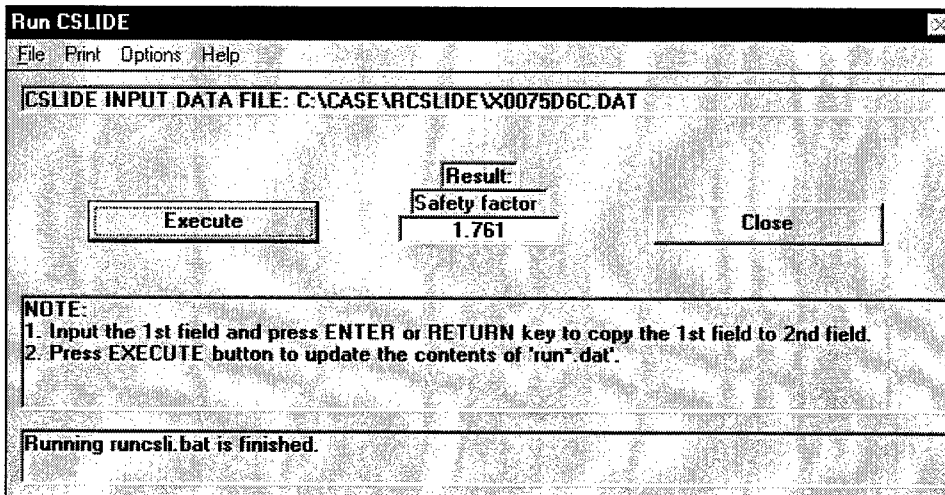

Figure B124. Factor of safety

Output file, X0075D6C.out

PROGRAM CSLIDE - ECHOPRINT

DATE: 13-APR-1999

TIME: 10.49.44

RETAINING WALL - CHECK FS RATIO 6C

FSP/FSA = 4.0

SINGLE FAILURE PLANE ANALYSIS

HYDROSTATIC WATER FORCE COMPUTED FOR WEDGES

NO OF CORNERS IN STRUCTURE -----	8
DENSITY OF CONCRETE -----	.1500 (KCF)
DENSITY OF WATER -----	.0625 (KCF)
WATER LEVEL LEFT SIDE -----	3.00 (FT)
WATER LEVEL RIGHT SIDE -----	3.00 (FT)
NO. OF SOIL LAYERS LEFT SIDE -----	2
NO. OF SOIL LAYERS RIGHT SIDE -----	1

ELEV. OF WEDGE-STRUCTURE INTERSECTION
ON ACTIVE SIDE OF STRUCTURE ----- .000 (FT)

FS PASSIVE / FS ACTIVE ----- 4.00

STRUCTURE INFORMATION

POINT -----	X-COORD -----	Y-COORD -----
1	.00	.00
2	.00	2.50
3	4.50	2.50
4	8.50	12.00
5	10.00	12.00
6	10.00	2.50
7	14.00	2.50
8	14.00	.00

LEFT-SIDE SOIL DATA

LAYER NO.	FRICTION ANGLE (DEG)	COHESION (KSF)	UNIT WEIGHT (KCF)	ELEV AT STRUCTURE (FT)
1	32.00	.0000	.111	12.00
2	32.00	.0000	.120	3.00

LAYER NO	POINT NO. 1 X-COORD	POINT NO. 1 Y-COORD	POINT NO. 2 X-COORD	POINT NO. 2 Y-COORD
1	-500.00	15.00	-6.00	15.00
2	-500.00	3.00	*****	*****

SOIL DATA BELOW STRUCTURE

FRICTION ANGLE ----- 32.00
 COHESION ----- .0000

RIGHT-SIDE SOIL DATA

LAYER NO.	FRICTION ANGLE (DEG)	COHESION (KSF)	UNIT WEIGHT (KCF)	ELEV AT STRUCTURE (FT)
1	32.00	.0000	.120	3.00

LAYER NO	POINT NO. 1 X-COORD	POINT NO. 1 Y-COORD
1	500.00	3.00

PROGRAM CSLIDE - FINAL RESULTS

DATE: 13-APR-1999

TIME: 10.49.44

RETAINING WALL - CHECK FS RATIO 6C

FSP/FSA = 4.0

SINGLE FAILURE PLANE ANALYSIS

HYDROSTATIC WATER FORCE COMPUTED FOR WEDGES

WEDGE NUMBER	HORIZONTAL LOADS		VERTICAL LOAD (KIPS)
	LEFT SIDE (KIPS)	RIGHT SIDE (KIPS)	
1	.000	.000	.000
2	.000	.000	.000
3	.000	.000	7.945
4	.000	.000	.000

WATER PRESSURES ON WEDGES

LEFT-SIDE WEDGES

WEDGE NO.	TOP PRESSURE (KSF)	BOTTOM PRESSURE (KSF)
1	.000	.000
2	.000	.188

STRUCTURAL WEDGE

X-COORD. (FT)	PRESSURE (KSF)
.00	.188
14.00	.188

RIGHT-SIDE WEDGES

WEDGE NO.	TOP PRESSURE (KSF)	BOTTOM PRESSURE (KSF)
4	.000	.188

WEDGE NUMBER	FAILURE ANGLE (DEG)	TOTAL LENGTH (FT)	WEIGHT OF WEDGE (KIPS)	SUBMERGED LENGTH (FT)	UPLIFT FORCE (KIPS)
1	-52.936	15.038	5.876	.000	.000
2	-52.936	3.760	3.173	3.760	.352
3	.000	14.000	10.238	14.000	2.625
4	42.363	4.452	.592	4.452	.417

WEDGE NUMBER	NET FORCE ON WEDGE (KIPS)
--------------	---------------------------

1	-3.875
2	-2.234
3	5.519
4	.590

SUM OF FORCES ON SYSTEM ---- .000
 FACTOR OF SAFETY ----- 1.761

Wedge plots. The wedge plots are given in Figures B125-B128.

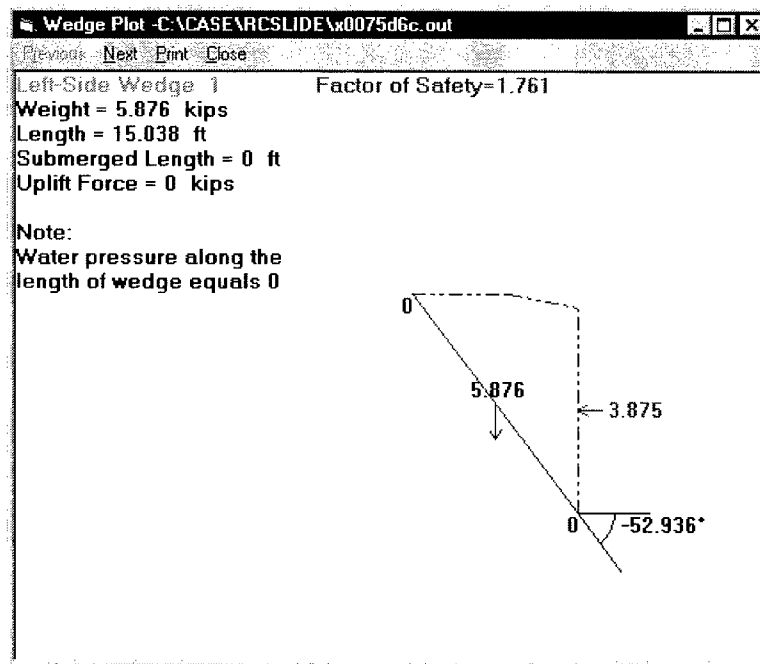

Figure B125. Left-side Wedge 1 Problem 6C

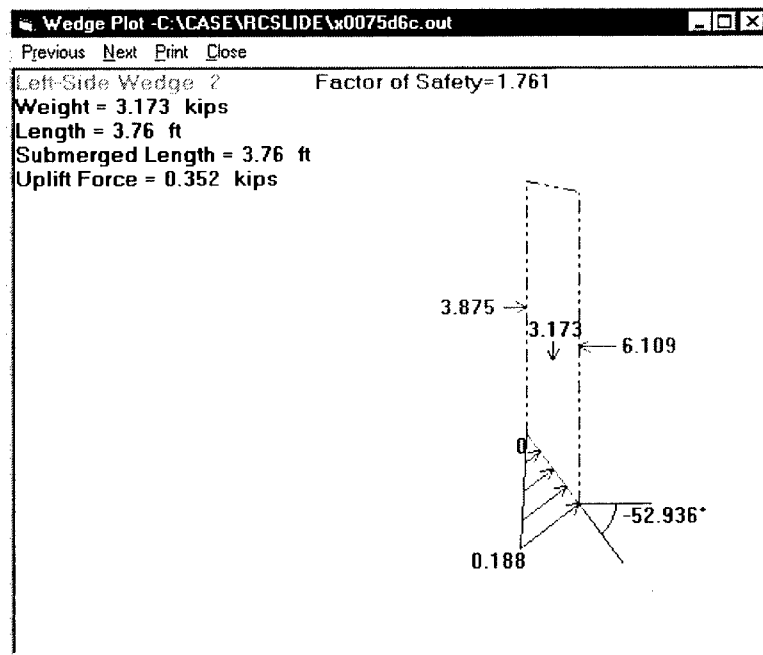

Figure B126. Left-side Wedge 2 Problem 6C

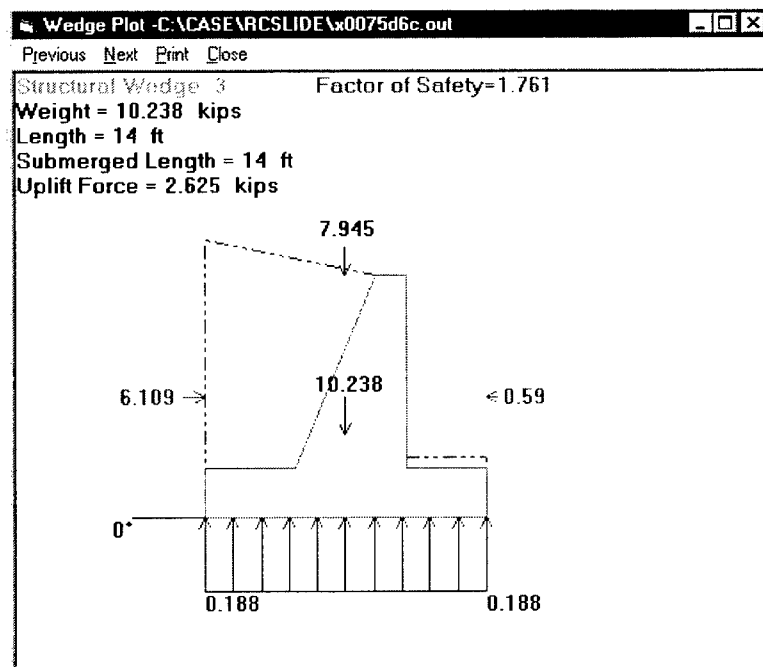

Figure B127. Structural Wedge 3 Problem 6C

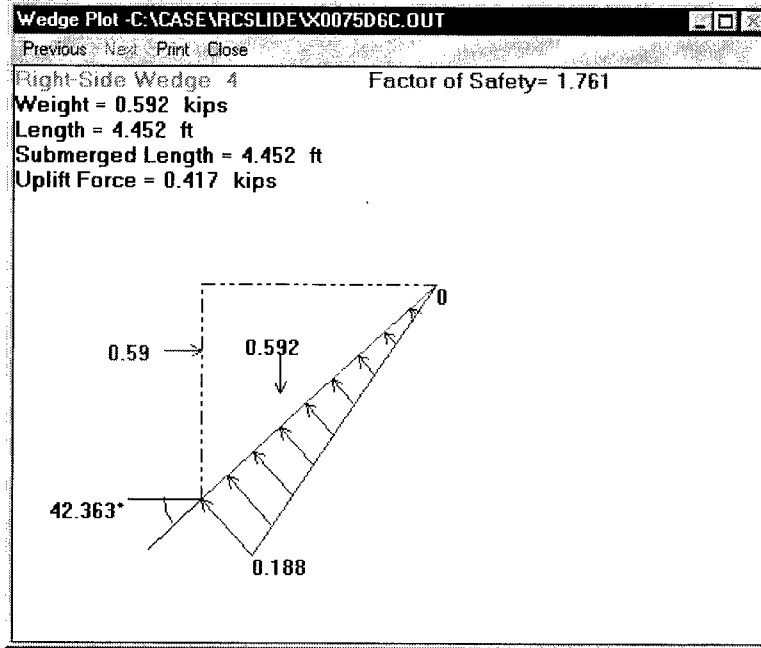

Figure B128. Right-side Wedge 4 Problem 6C

By increasing the safety factor of the passive side, the strength parameters ϕ and c are not developed as much as they are on the active side.

$$\phi_d = \tan^{-1}\left(\frac{\tan \phi}{FS}\right) \quad c_d = \frac{c_i}{FS}$$

While this reduces the strength of the passive soil, the ratio of 4:1 is *not* a direct measure of this strength reduction.

To assess the reduction in strength on the passive side because of the passive FS increase, the net forces of Wedge 4 are compared:

FS_{active}	$FS_{passive}$	Ratio of $FS_{passive}$ to FS_{active}	New Force of Wedge 4, kips	Percent Reduction
1.000	1.000	1.0	1.123 (fully developed)	0.0
1.800	1.800	1.0	0.793 (balance point)	29.4
1.761	7.044	4.0	0.590	47.5

If the net force from the passive wedge should be less than 0.590 kips, the problem should be reanalyzed using a larger FS ratio. Whereas, if the passive net force should be greater than 0.590 kips, decrease the FS ratio.

Problem 7

This example is a CSLIDE analysis of a U-wall. Earthquake conditions are applied to the system (horizontal earthquake acceleration coefficient of 0.20), and resulting forces are determined using a safety factor of 1.10.

If a channel-type structure, as shown in Figure B129, has soil or water elevations above either one or both sides of the channel, CSLIDE computes the horizontal and vertical loads of that part of the material that lies within the channel. Otherwise, if soil or water elevations are at or below both sides of the channel, the user must model any loads within the channel as external horizontal and vertical loads on the structural wedge.

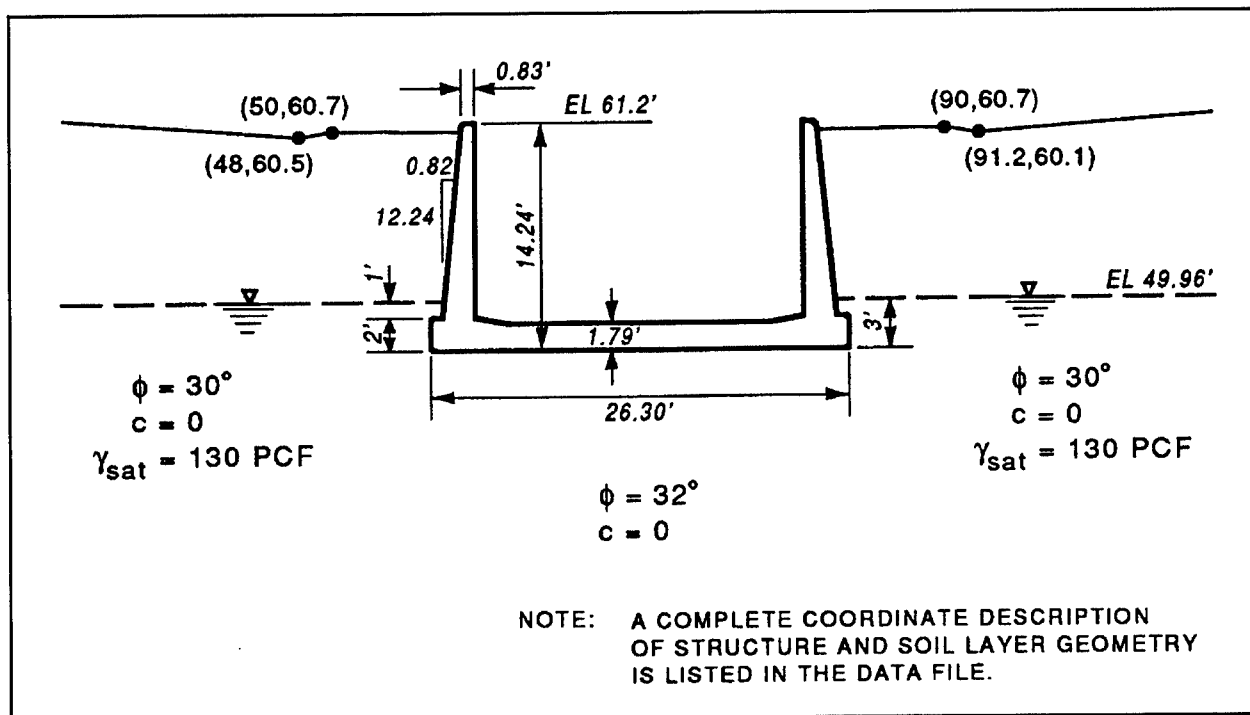

Figure B129. U-wall, Problem 7, soil-structure system

Input file, X0075D7.dat

50 TITL U-WALL CHANNEL	(Title)
160 STRU 14 .15 46.96 .5	(Structural information)
170 56.85 46.96	(Structure coordinates)
180 56.85 48.96	
190 57.35 48.96	
200 58.17 61.20	
210 59.00 61.20	
220 59.00 48.96	
230 60.88 48.75	

240 79.12 48.75
 250 81.00 48.96
 260 81.00 61.20
 270 81.83 61.20
 280 82.65 48.96
 290 83.15 48.96
 300 83.15 46.96
 310 SOLT 1 5 30 0 .13 60.70 (Left-side soil layer description)
 320 3.50 64.00 (Soil layer coordinate points)
 330 16.50 64.00
 340 24.50 62.00
 350 48.00 60.50
 360 50.00 60.70
 370 SORT 1 3 30 0 .130 60.7 (Right-side soil layer description)
 380 90.00 60.70 (Soil layer coordinate points)
 390 91.20 60.10
 400 134.50 61.50
 410 SOST 32 0
 420 METH 2 (Analysis method)
 430 WATR 49.96 49.96 .0625 -1 (Water description)
 440 EQAC .00 .20 (Earthquake conditions)
 450 FACT 1.10 1.10 1 (Factor of safety)
 460 END (Termination)

As in Problem 5A, a specific factor of safety is obtained by setting both the upper and lower limit to the required value (Figure B130).

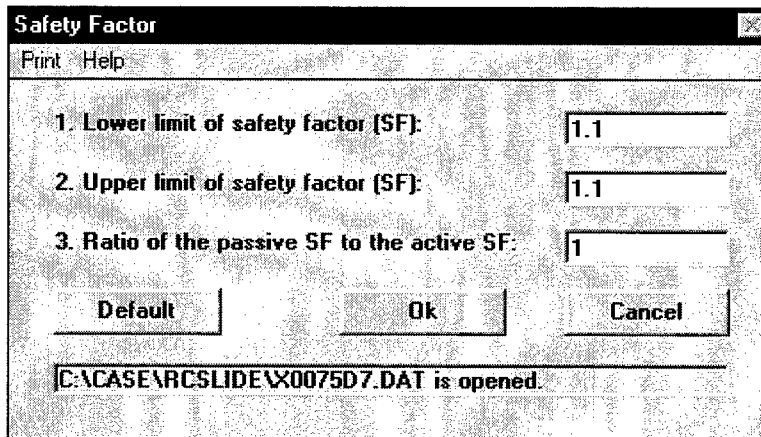

Figure B130. Safety factor window

Earthquake conditions are supplied on the window obtained (Figure B131) by selecting **Earthquakes** on the **Edit** menu.

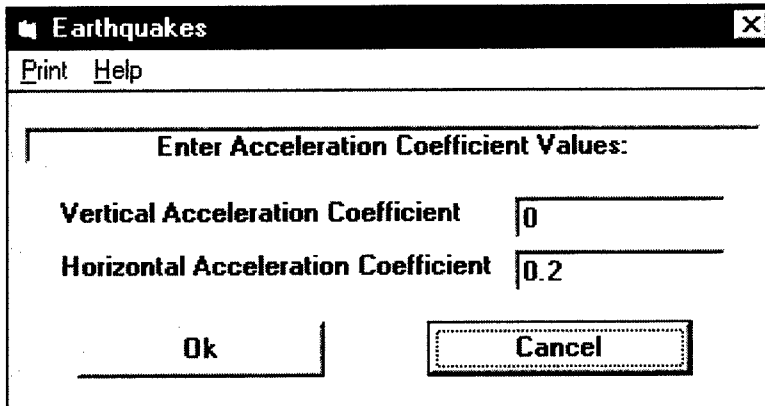

Figure B131. Earthquake coefficients window

Problem output

Factor of safety. The specified 1.1 factor of safety value is obtained from the analysis (Figure B132).

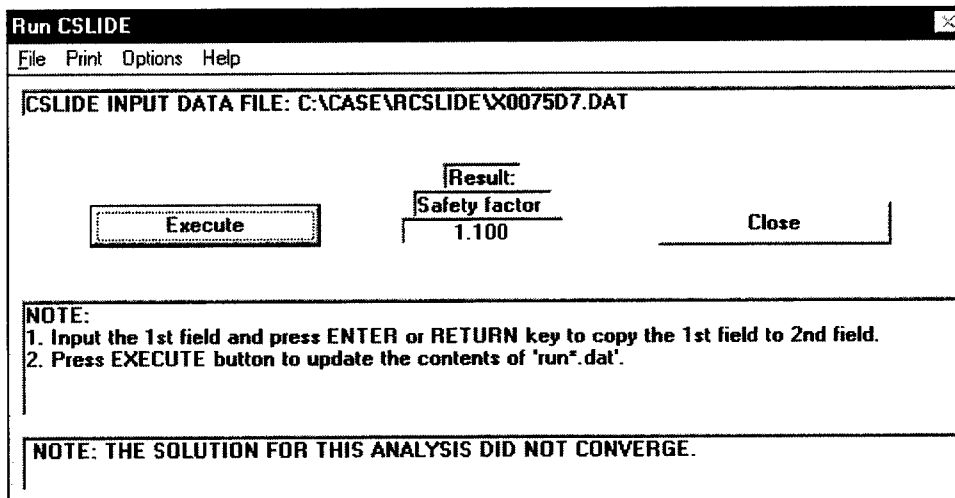

Figure B132. Factor of safety

Output file, X0075D7.out

As in Problem 5A, the heading “Stationary Solution” indicates the solution did not converge because the safety factor was fixed by using equivalent upper and lower limits.

PROGRAM CSLIDE - ECHOPRINT

DATE: 13-APR-1999

TIME: 10.50.54

U-WALL CHANNEL

MULTI FAILURE PLANE ANALYSIS

HYDROSTATIC WATER FORCE COMPUTED FOR WEDGES

NO OF CORNERS IN STRUCTURE ----- 14
DENSITY OF CONCRETE ----- .1500 (KCF)
DENSITY OF WATER ----- .0625 (KCF)
WATER LEVEL LEFT SIDE ----- 49.96 (FT)
WATER LEVEL RIGHT SIDE ----- 49.96 (FT)
NO. OF SOIL LAYERS LEFT SIDE ----- 1
NO. OF SOIL LAYERS RIGHT SIDE ----- 1

ELEV. OF WEDGE-STRUCTURE INTERSECTION
ON ACTIVE SIDE OF STRUCTURE ----- 46.960 (FT)

STRUCTURE INFORMATION

POINT -----	X-COORD -----	Y-COORD -----
1	56.85	46.96
2	56.85	48.96
3	57.35	48.96
4	58.17	61.20
5	59.00	61.20
6	59.00	48.96
7	60.88	48.75
8	79.12	48.75
9	81.00	48.96
10	81.00	61.20
11	81.83	61.20
12	82.65	48.96
13	83.15	48.96
14	83.15	46.96

50.00 % OF THE STRUCTURAL BASE IS IN COMPRESSION

LEFT-SIDE SOIL DATA

LAYER NO.	FRICTION ANGLE (DEG)	COHESION (KSF)	UNIT WEIGHT (KCF)	ELEV AT STRUCTURE (FT)
1	30.00	.0000	.130	60.70

LAYER NO.	POINT NO. 1 X-COORD	POINT NO. 1 Y-COORD	POINT NO. 2 X-COORD	POINT NO. 2 Y-COORD	POINT NO. 3 X-COORD	POINT NO. 3 Y-COORD
1	3.50	64.00	16.50	64.00	24.50	62.00

LAYER NO.	POINT NO. 4 X-COORD	POINT NO. 4 Y-COORD	POINT NO. 5 X-COORD	POINT NO. 5 Y-COORD
1	48.00	60.50	50.00	60.70

SOIL DATA BELOW STRUCTURE

FRICTION ANGLE ----- 32.00
 COHESION ----- .0000

RIGHT-SIDE SOIL DATA

LAYER NO.	FRICTION ANGLE (DEG)	COHESION (KSF)	UNIT WEIGHT (KCF)	ELEV AT STRUCTURE (FT)
1	30.00	.0000	.130	60.70

LAYER NO.	POINT NO. 1 X-COORD	POINT NO. 1 Y-COORD	POINT NO. 2 X-COORD	POINT NO. 2 Y-COORD	POINT NO. 3 X-COORD	POINT NO. 3 Y-COORD
1	90.00	60.70	91.20	60.10	134.50	61.50

SEISMIC ACCELERATIONS

VERTICAL ----- .000
 HORIZONTAL ----- .200

SAFETY FACTOR DESCRIPTION

LOWER LIMIT OF F.S. ----- 1.10
UPPER LIMIT OF F.S. ----- 1.10

STATIONARY SOLUTION

DATE: 13-APR-1999

TIME: 10.50.54

U-WALL CHANNEL

MULTIPLE FAILURE PLANE ANALYSIS

HYDROSTATIC WATER FORCE COMPUTED FOR WEDGES

WEDGE NUMBER	HORIZONTAL LOADS		VERTICAL LOAD (KIPS)
	LEFT SIDE (KIPS)	RIGHT SIDE (KIPS)	
1	2.296	.000	.000
2	2.907	.000	2.727
3	4.490	.000	.000

WATER PRESSURES ON WEDGES

LEFT-SIDE WEDGES

WEDGE NO.	TOP PRESSURE (KSF)	BOTTOM PRESSURE (KSF)
1	.000	.188

STRUCTURAL WEDGE

X-COORD. (FT)	PRESSURE (KSF)
56.85	.188
83.15	.188

RIGHT-SIDE WEDGES

WEDGE NO.	TOP PRESSURE (KSF)	BOTTOM PRESSURE (KSF)
-----------	-----------------------	--------------------------

3	.000	.188
---	------	------

WEDGE NUMBER	FAILURE ANGLE (DEG)	TOTAL LENGTH (FT)	WEIGHT OF WEDGE (KIPS)	SUBMERGED LENGTH (FT)	UPLIFT FORCE (KIPS)
-----------------	---------------------------	-------------------------	------------------------------	-----------------------------	---------------------------

1	-46.7	18.953	11.482	4.119	.386
2	.000	26.300	11.810	26.300	4.931
3	27.9	29.364	22.452	6.421	.602

WEDGE NUMBER	NET FORCE ON WEDGE (KIPS)
-----------------	---------------------------------

1	-6.452
2	2.549
3	27.740

SUM OF FORCES ON SYSTEM ---- 23.837

FACTOR OF SAFETY ----- 1.100

* NOTE * THE SOLUTION HAS NOT CONVERGED.

Structure plot (Figure B133).

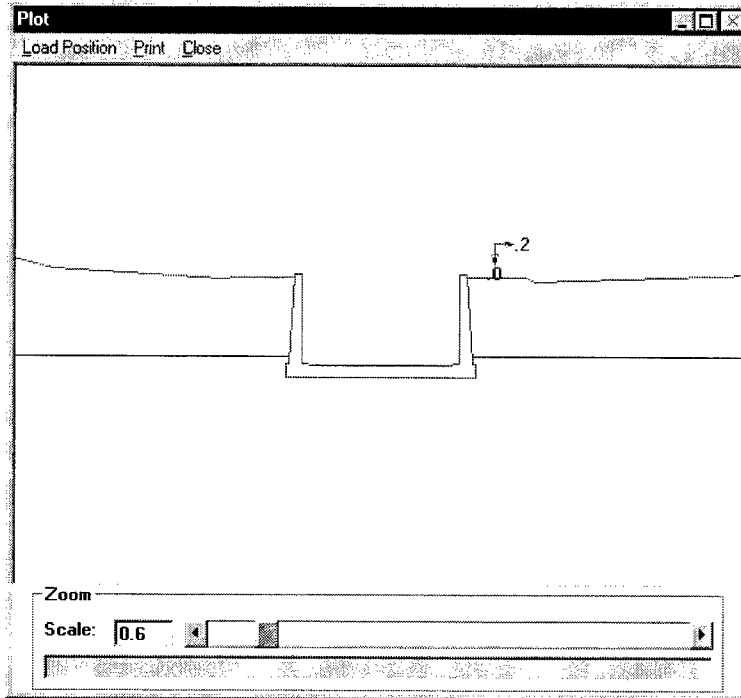

Figure B133. Structure plot – Problem 7

Failure Surface plot (Figure B134).

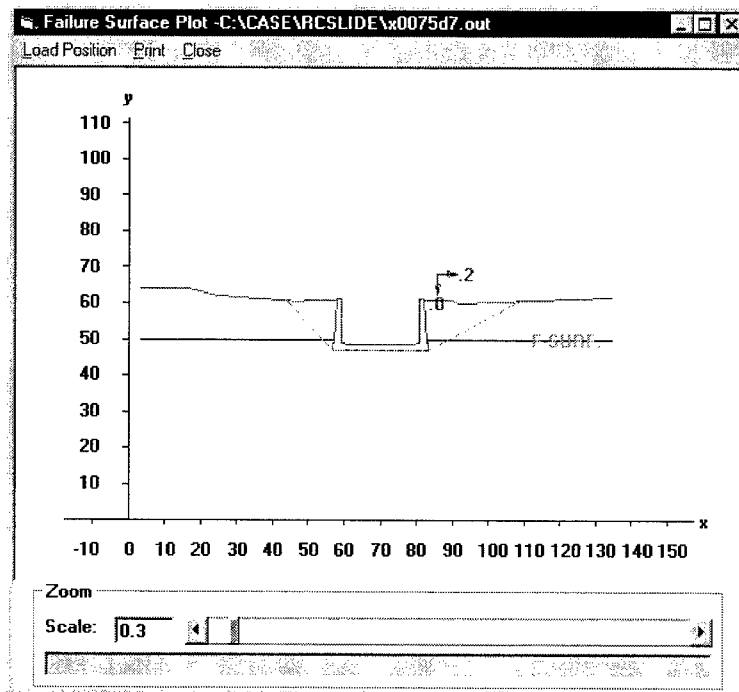

Figure B134. Failure Surface plot – Problem 7

Wedge plots (Figures B135-B137).

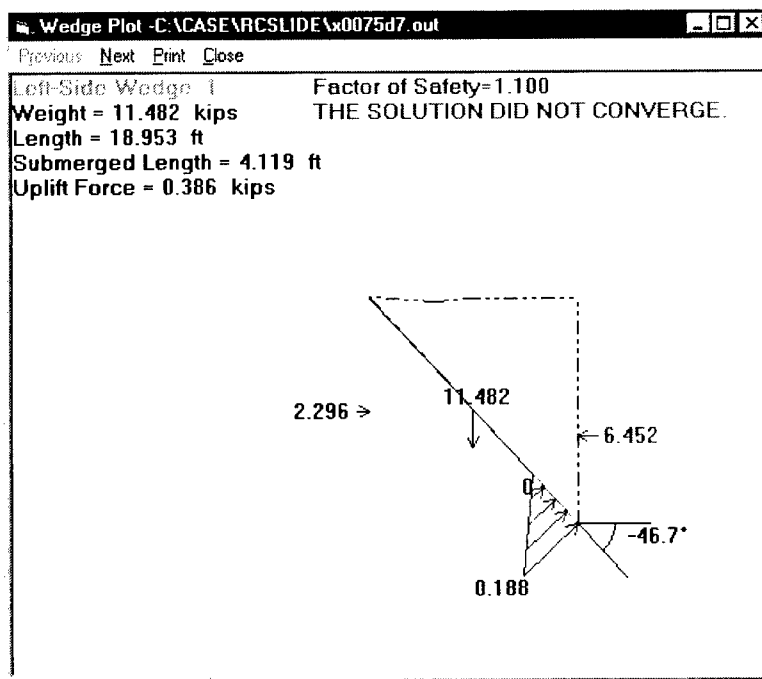

Figure B135. Left-side Wedge 1 Problem 7

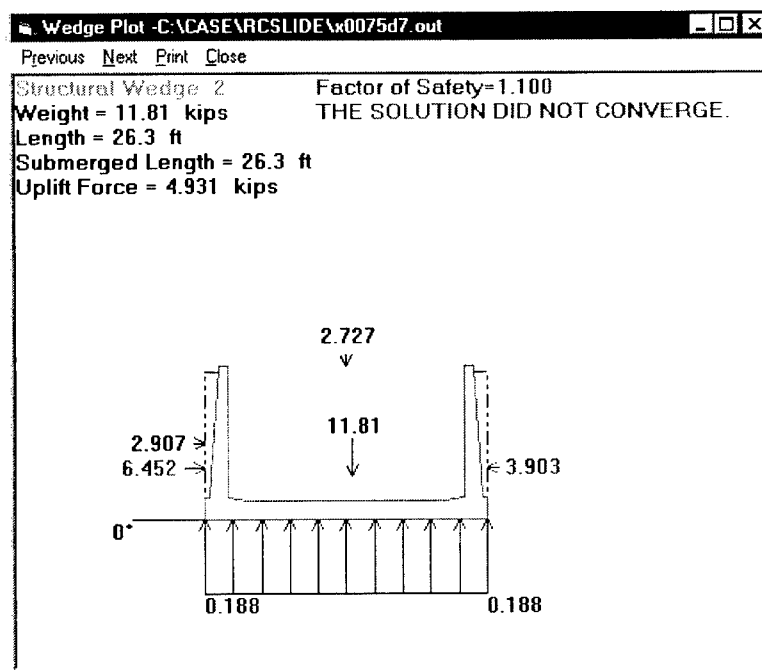

Figure B136. Structural Wedge 2 Problem 7

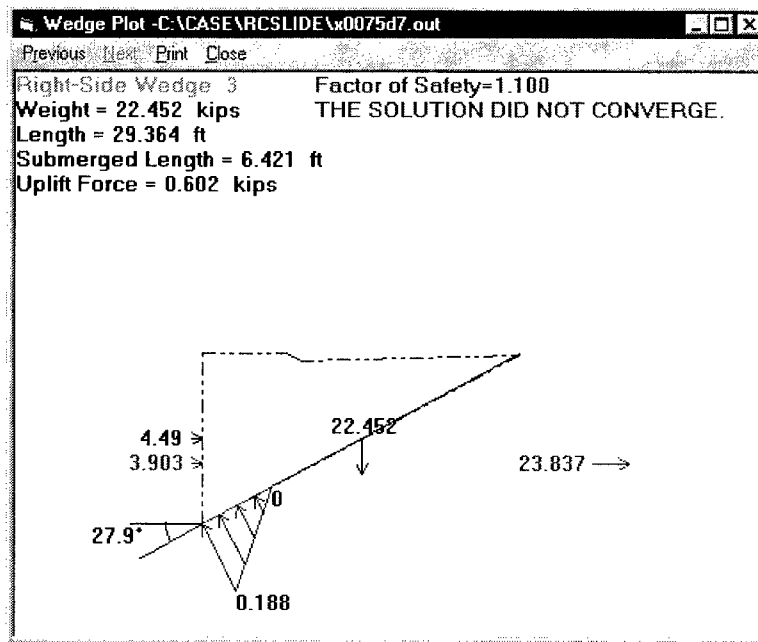

Figure B137. Right-side Wedge 3 Problem 7

Appendix C

RCSLIDE Example Problems

This chapter presents two problems to clarify the input and output for RCSLIDE by creating the input file, running the analysis, and reviewing the results. A listing of the input CSLIDE and reliability files is also included.

Problem 1

This example illustrates using RCSLIDE to model a simple retaining wall for sliding analysis using correlated random variables. Find the sliding factor of safety for the wall in Figure C1 using a negative correlation coefficient, -0.5, between the normally distributed angles of internal friction (ϕ) and respective cohesion values of soil (c) for all soil layers. Determine the probability of unsatisfactory performance for the wall under sliding conditions using the advanced second moment method for reliability assessment.

Input CSLIDE Data File: X0075D1C.dat

```
001 TITL - RETAINING WALL with correlation
002 TITL
003 TITL
004 TITL
005 STRU 8 0.15 0.0 1.0
006 0.00 0.00
007 0.00 2.00
008 6.00 2.00
009 6.00 14.00
010 8.00 14.00
011 8.00 2.00
012 12.00 2.00
013 12.00 0.00
014 SOLT 1 1 28.0 0.05 0.12 14.0
015 -500.00 14.00
016 SORT 1 1 28.0 0.05 0.12 4.0
017 500.00 4.00
```

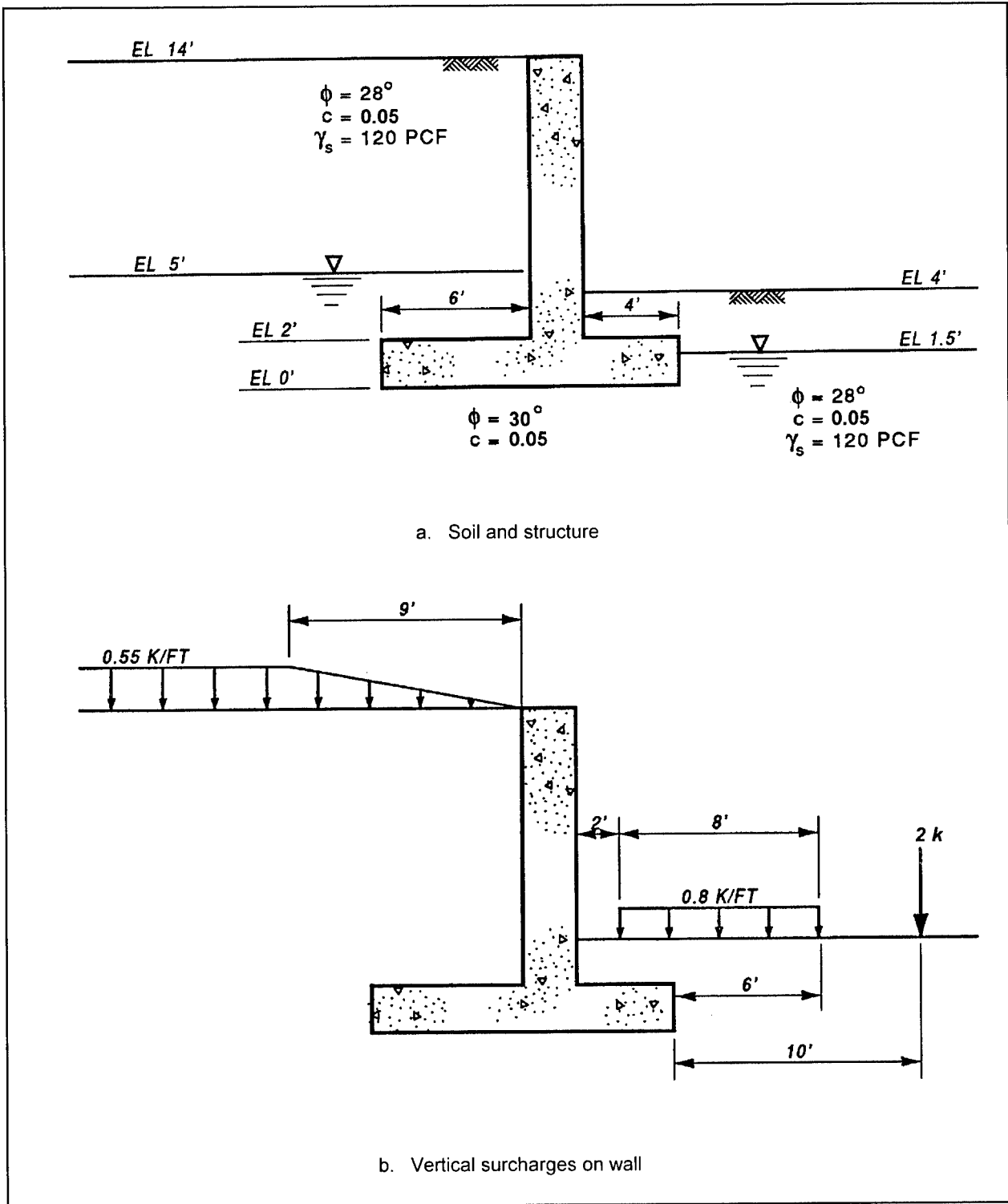

Figure C1. Retaining wall

```
018 SOST 30.0 0.05
019 METH 1
020 WATR 5.0 1.0 0.0625 -1
021 END
```

Input Reliability Data File: RELID1C.dat

Note that this file is created by RCSLIDE from the data values entered on the input data screens.

```
TITL ASM/MCS data file for X0075D1C.dat - correlation
STRU0001 1.500000E-01 1.500000E-01 C NOR
SOLT0103 2.800000E+01 3.000000E-01 C NOR
SOLT0104 5.000000E-02 2.000000E-01 C NOR -0.5
SOLT0105 1.200000E-01 1.000000E-01 C NOR
SORT0103 2.800000E+01 3.000000E-01 C NOR
SORT0104 5.000000E-02 2.000000E-01 C NOR -0.5
SORT0105 1.200000E-01 1.000000E-01 C NOR
SOST0003 3.000000E+01 3.000000E-01 C NOR
SOST0004 5.000000E-02 1.000000E-02 C NOR -0.5
WATR0001 5.000000E+00 1.000000E+00 S NOR
WATR0002 1.000000E+00 1.000000E+00 S NOR
END
```

RCSLIDE input sequence

The screen displayed in Figure C2 is used to assign problem titles for both the CSLIDE and Reliability data files.

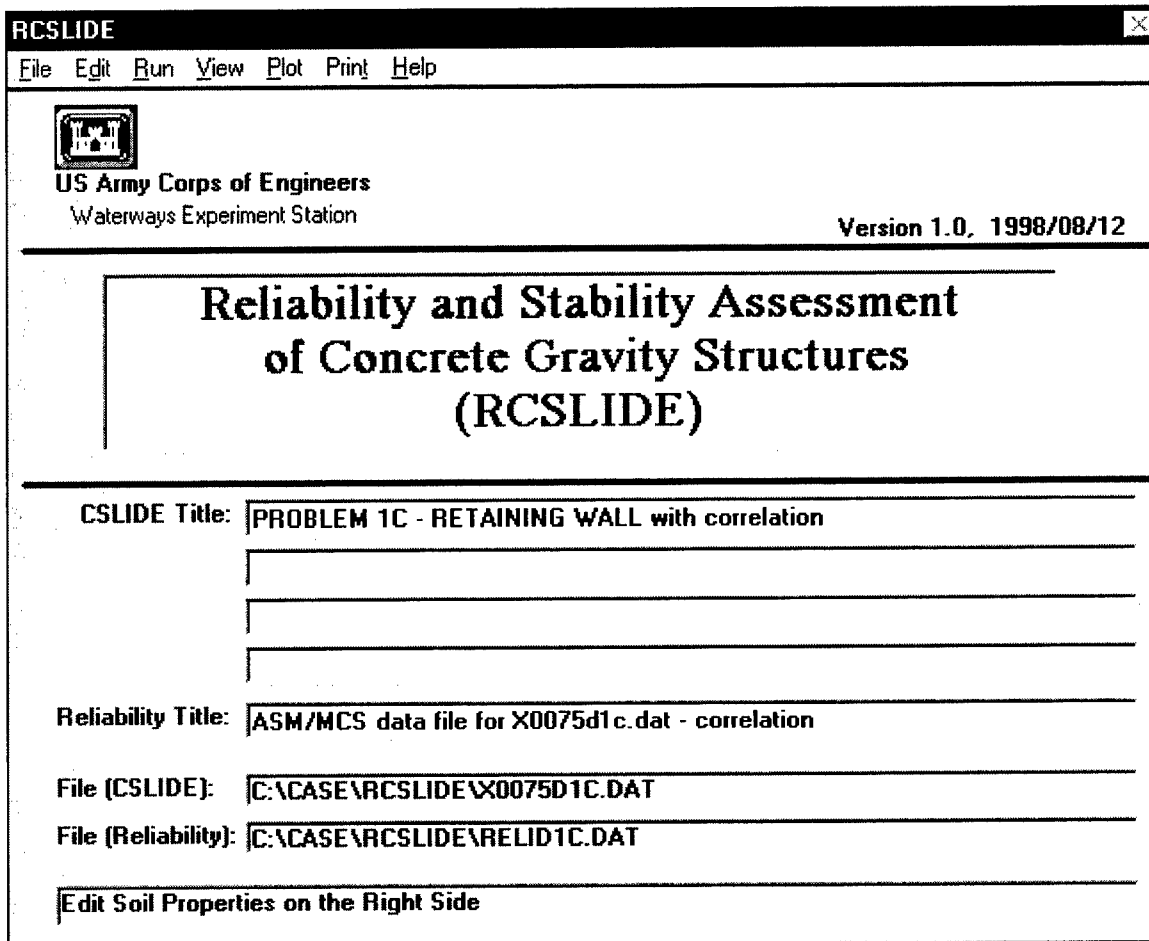

Figure C2. Title and problem description

The **Structural Information**, **Soil Properties**, and **Soil Coordinates** windows can be selected from the **Edit** menu to enter their required values as shown in Figures C3-C7. Depending upon the location of the soil layer, either **Left** or **Right** is selected from the **Soil Properties** and **Soil Coordinates** menu. It is recommended that no more than three soil layers on each side be used. The correlation coefficient between the angle of internal friction and cohesion of the soil is entered as Item 7 on the soil properties window (Figures C4 and C6).

RCSLIDE Structural Information

Delete Print Help

	a. Mean	b. Stddv/COV	c. Code	d. Distribution
1. Unit weight of concrete (kcf):	0.15	0.15	C	NOR
2. Elevation of failure angle at left side (ft):	0	0	C	NOR
3. Fraction of base in compression (<=1):	1	0	C	NOR

Default

Point count: 8
 [(Clockwise order from lower left corner)]

4. Point No. (max=20): 1

5. X-coord.: 0

6. Y-coord.: 0

Enter ->

C:\CASE\RCSLIDE\RELID1C.DAT is opened.

Node No.	X-coord.	Y-coord.
Node 1	0.0000	0.0000
Node 2	0.0000	2.0000
Node 3	6.0000	2.0000
Node 4	6.0000	14.0000
Node 5	8.0000	14.0000
Node 6	8.0000	2.0000
Node 7	12.0000	2.0000
Node 8	12.0000	0.0000

Ok Cancel

Figure C3. Structural description

RCSLIDE -- Soil Property Description

Print Help

Method: 1=Single plane Side: SOLT=Left-side soil description

Total layers: 1

1. Layer number (max=5): 1

2. Total points (max=5): 1

	a. Mean	b. Stddv/COV	c. Code	d. Distribution
3. Angle of internal friction of the layer (deg):	28	0.3	C	NOR
4. Cohesion of the layer (ksf)	0.05	0.2	C	NOR
5. Saturated or moist unit weight (kcf):	0.12	0.1	C	NOR
6. Elevation of the top of the layer (ft):	14			
7. Correlation coefficient between angle of internal friction and cohesion of the layer:	-0.5			

Ok Cancel

Figure C4. Soil properties (left side)

Soil Coordinate Description [X]

Print Help

[Side] Soil description: [SOLT=Left-side soil description]

Total layers: [1]

1. Layer number (max=5): [1] [▲▼]

2. Point No. (max=5): [1] [▲▼]

3. X-coord.: [-500.0000]

4. Y-coord.: [14.0000] Enter ->

	X-coord.	Y-coord.
Layer (1)		
Point 1	-500.0000	14.0000
Point 2		
Point 3		
Point 4		
Point 5		
Layer (2)		

Message

Ok Cancel

Figure C5. Soil coordinates (left side)

RC SLIDE -- Soil Property Description [X]

Print Help

Method: [1=Single plane] Side: [SORT=Right-side soil description]

Total layers: [1]

1. Layer number (max=5): [1] [▲▼]

2. Total points (max=5) [1]

	a. Mean	b. Stddv/COV	c. Code	d. Distribution
3. Angle of internal friction of the layer (deg):	[28]	[0.3]	[C ▼]	[NOR ▼]
4. Cohesion of the layer (ksf)	[0.05]	[0.2]	[C ▼]	[NOR ▼]
5. Saturated or moist unit weight (kcf):	[0.12]	[0.1]	[C ▼]	[NOR ▼]
6. Elevation of the top of the layer (ft):	[4]			
7. Correlation coefficient between angle of internal friction and cohesion of the layer:	[-0.5]			

Ok Cancel

Figure C6. Soil properties (right side)

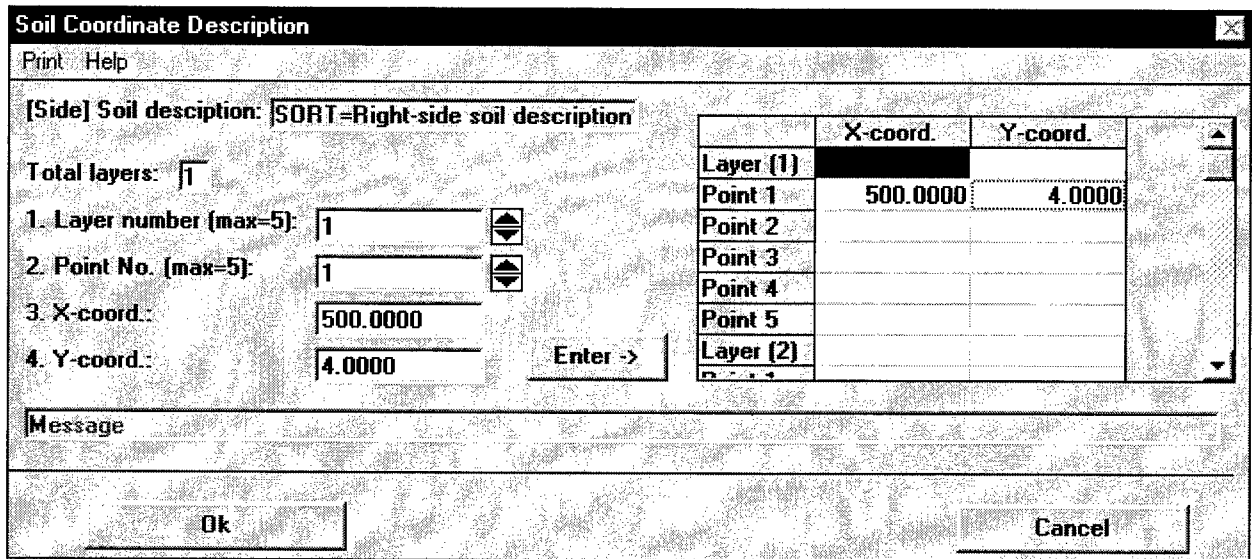

Figure C7. Soil coordinates (right side)

A description of the soil below the structure is required to analyze this retaining wall. To display the following screen (Figure C8), select **Edit**, then **Soil Properties**, and finally **Below**. The correlation coefficient between c and ϕ is entered as Item 7.

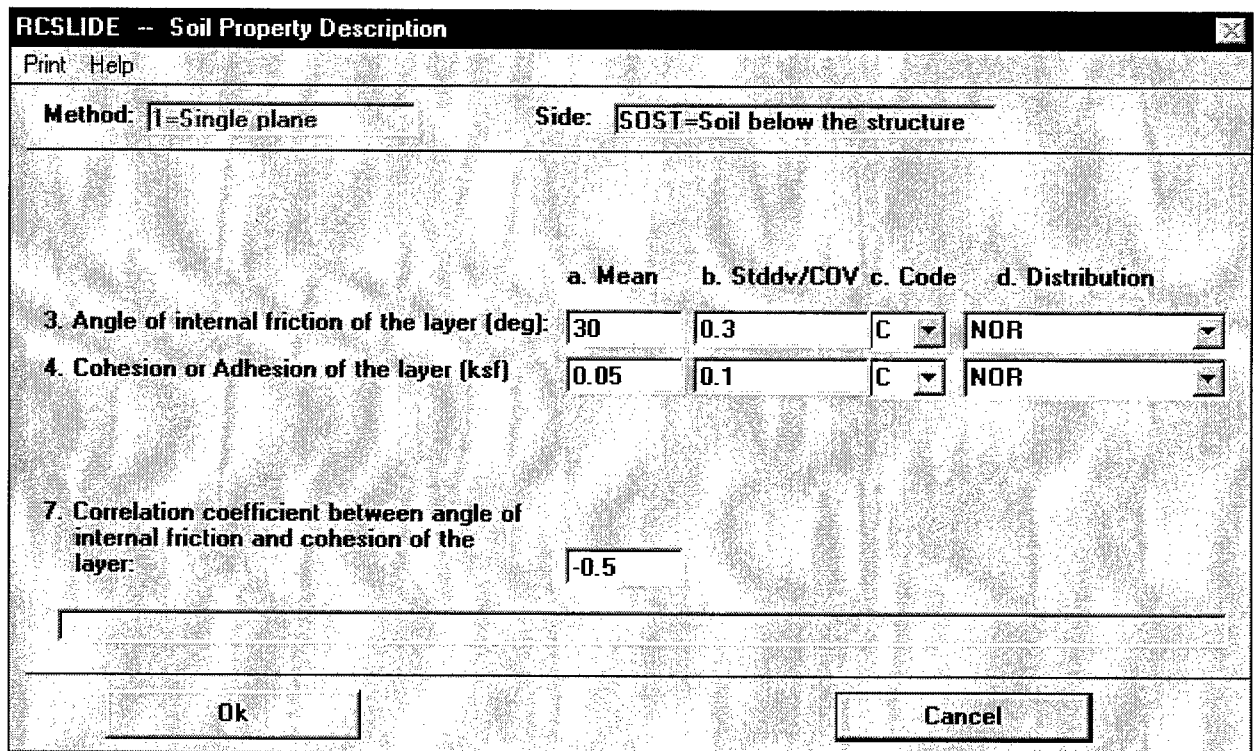

Figure C8. Soil properties below structure

Single-plane analysis is chosen as the method of analysis by selecting **Edit**, **Soil Properties**, and **Method** as shown in Figure C9.

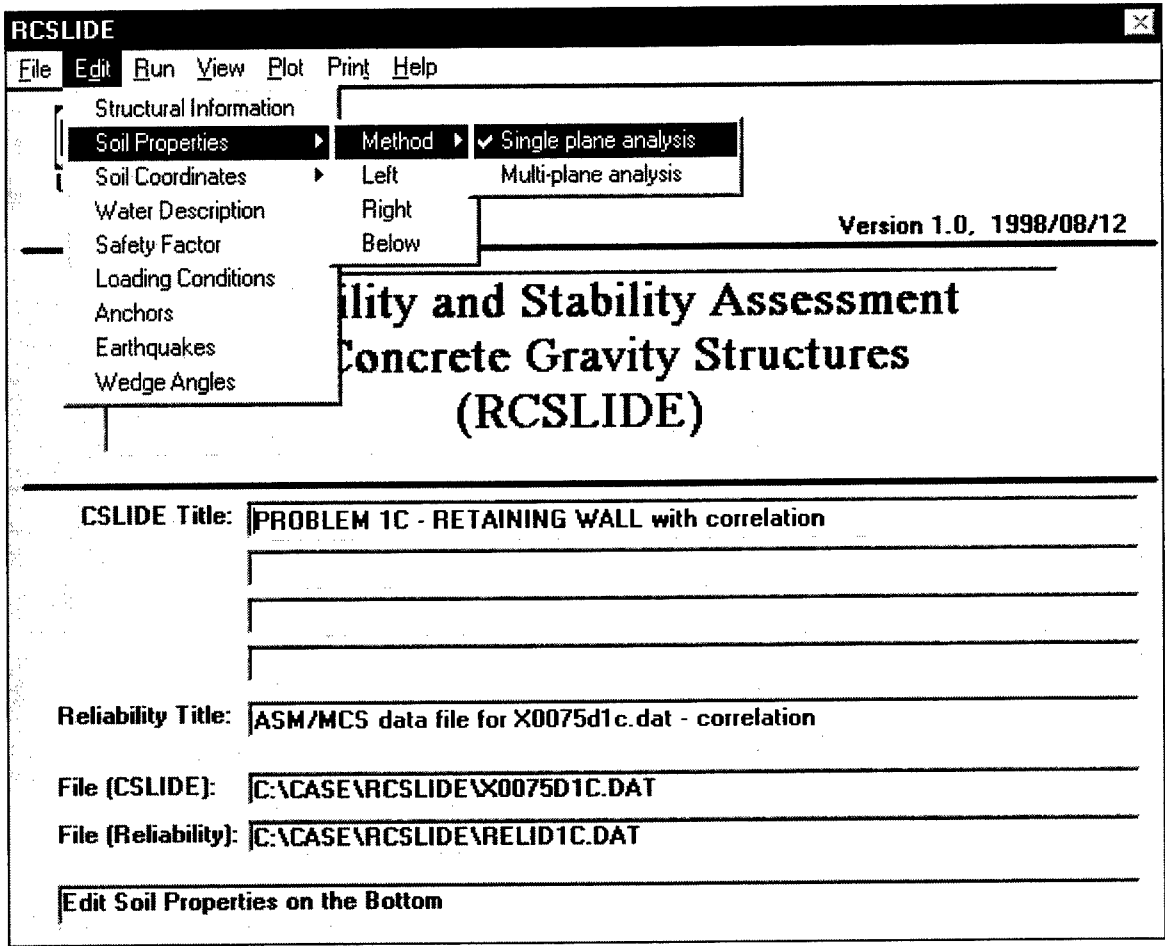

Figure C9. Select analysis method

Values for the water description may be entered on the screen shown in Figure C10. This screen is obtained by selecting **Edit**, then **Water Description**. For this problem, seepage pressures are computed using the line-of-creep method.

Since no safety factor values were entered, the program uses the default values.

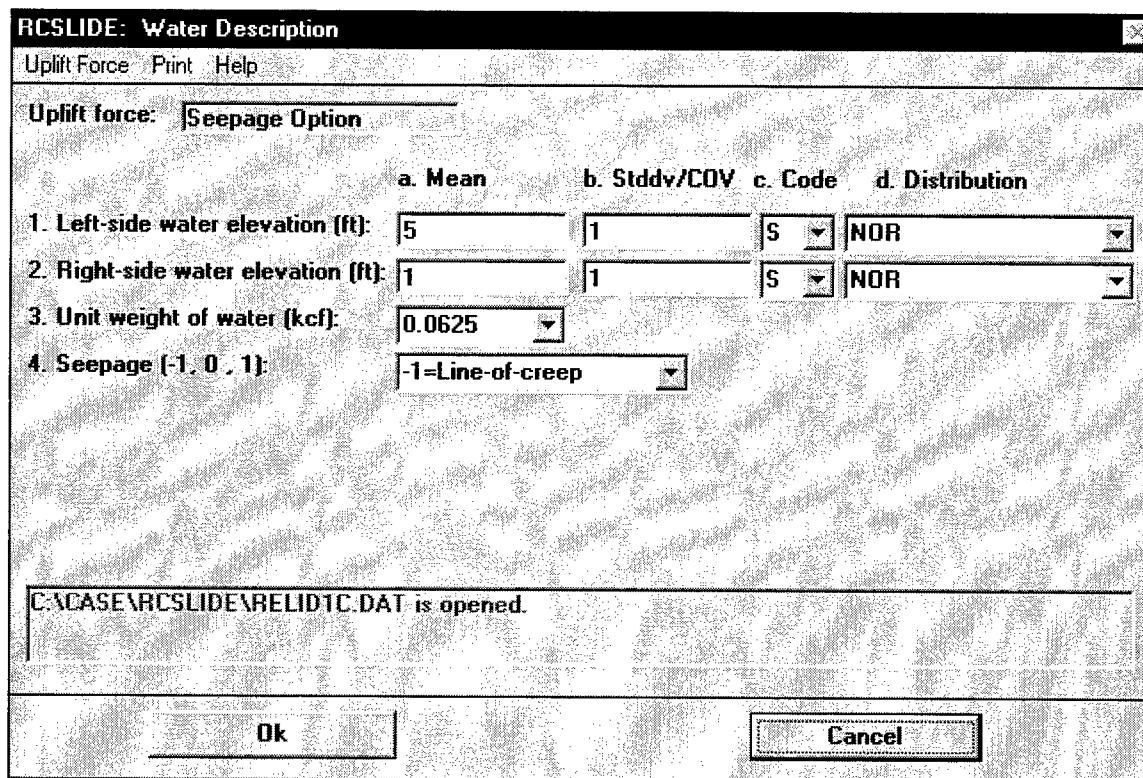

Figure C10. Water description

RC SLIDE execution – CSLIDE analysis

To perform a CSLIDE analysis, select the **Run** option from the main menu bar and then select **Run RC SLIDE**. The following window appears (Figure C11).

This option runs only a CSLIDE analysis and computes the safety factor when the **Execute** button is selected (Figure C12). Additional CSLIDE output will be shown later in this appendix.

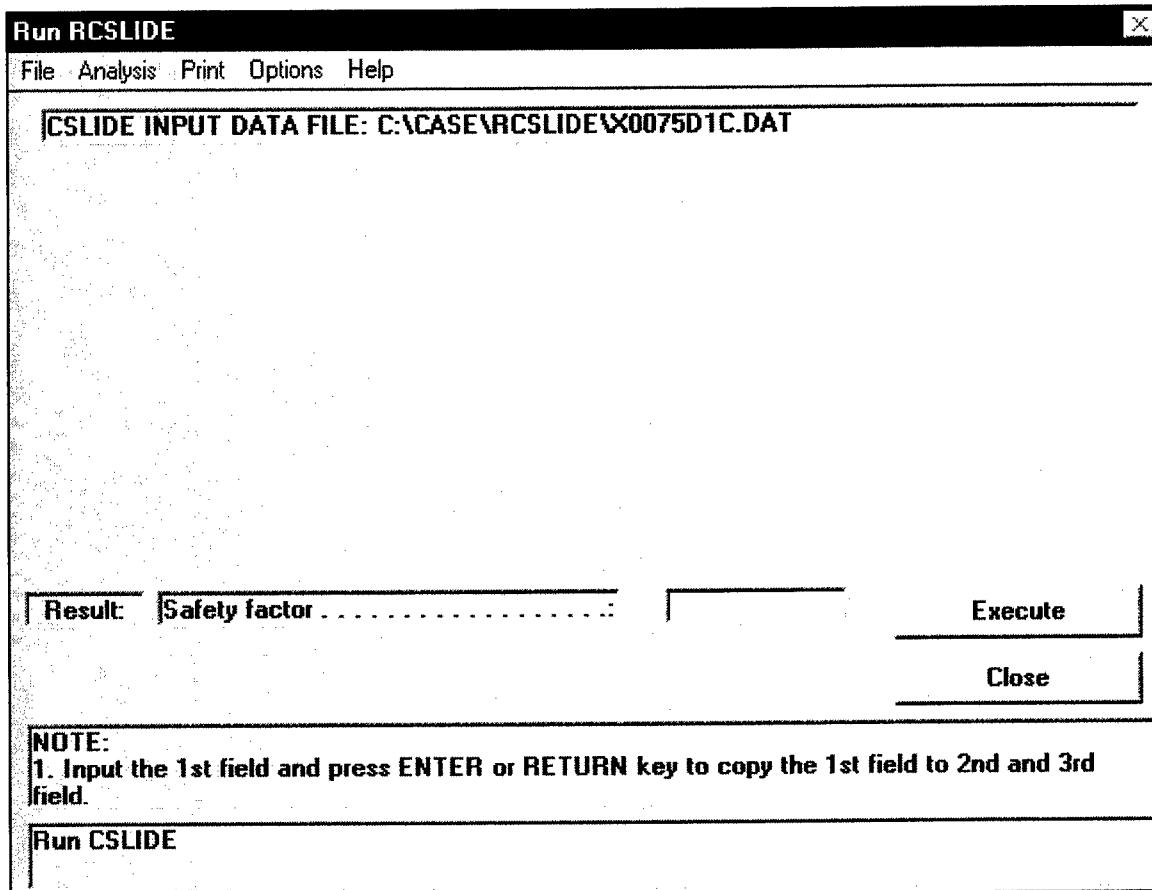

Figure C11. RCLIDE analysis window

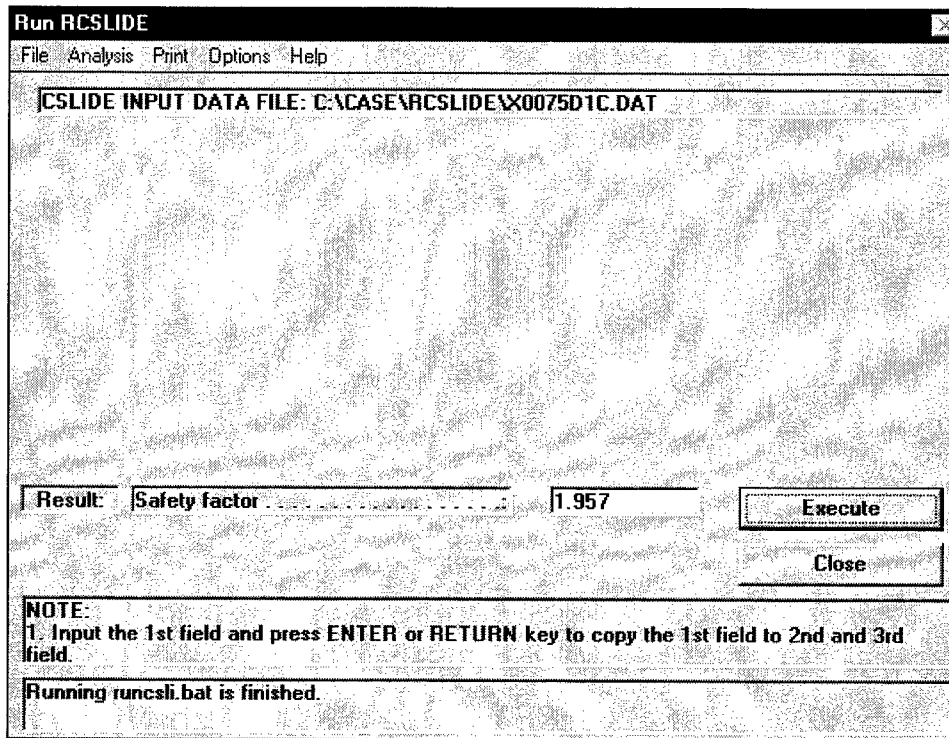

Figure C12. Resultant safety factor from CSLIDE analysis

RCLSLIDE execution – ASM method

To compute the probability of unsatisfactory performance using the advanced second moment method, select the **Run** option from the main menu, then select **Run RCLSLIDE** and Figure C11 will appear. Select **Analysis** on the menu bar and then choose **Run ASM**, and several additional fields will be displayed on the Run RCLSLIDE screen as shown in Figure C13. These items were discussed in Chapter 10.

Run RCSLIDE [X]

File Analysis Print Options Help

RCSLIDE INPUT DATA FILE: C:\CASE\RCSLIDE\X0075D1C.DAT

RELIABILITY INPUT DATA FILE: C:\PROGRA~1\CASE\RCSLIDE\RELID1C.DAT

(ASM) 'runasm.dat' contains the following information:

Max iteration for finding reliability index:	<input type="text" value="10"/>	
Tolerance for reliability index:	<input type="text" value="1E-02"/>	
Ratio of σ_X/X for random variables:	<input type="text" value="1E-03"/>	
Increment for finding reliability index:	<input type="text" value="0.25"/>	
1=Absolute or 2=Relative Tolerance	<input type="text" value="2"/>	

Result:	<input type="text" value="Safety factor"/>	<input type="text"/>	Execute
	<input type="text" value="Reliability index"/>	<input type="text"/>	
	<input type="text" value="(Unsatisfactory performance probability:"/>	<input type="text"/>	Close

NOTE:
1. Input the 1st field and press ENTER or RETURN key to copy the 1st field to 2nd and 3rd field.

Run ASM

Figure C13. ASM execution screen

The ASM option of RCSLIDE returns results including the safety factor, reliability index, and probability of unsatisfactory performance when the **Execute** button is selected (Figure C14).

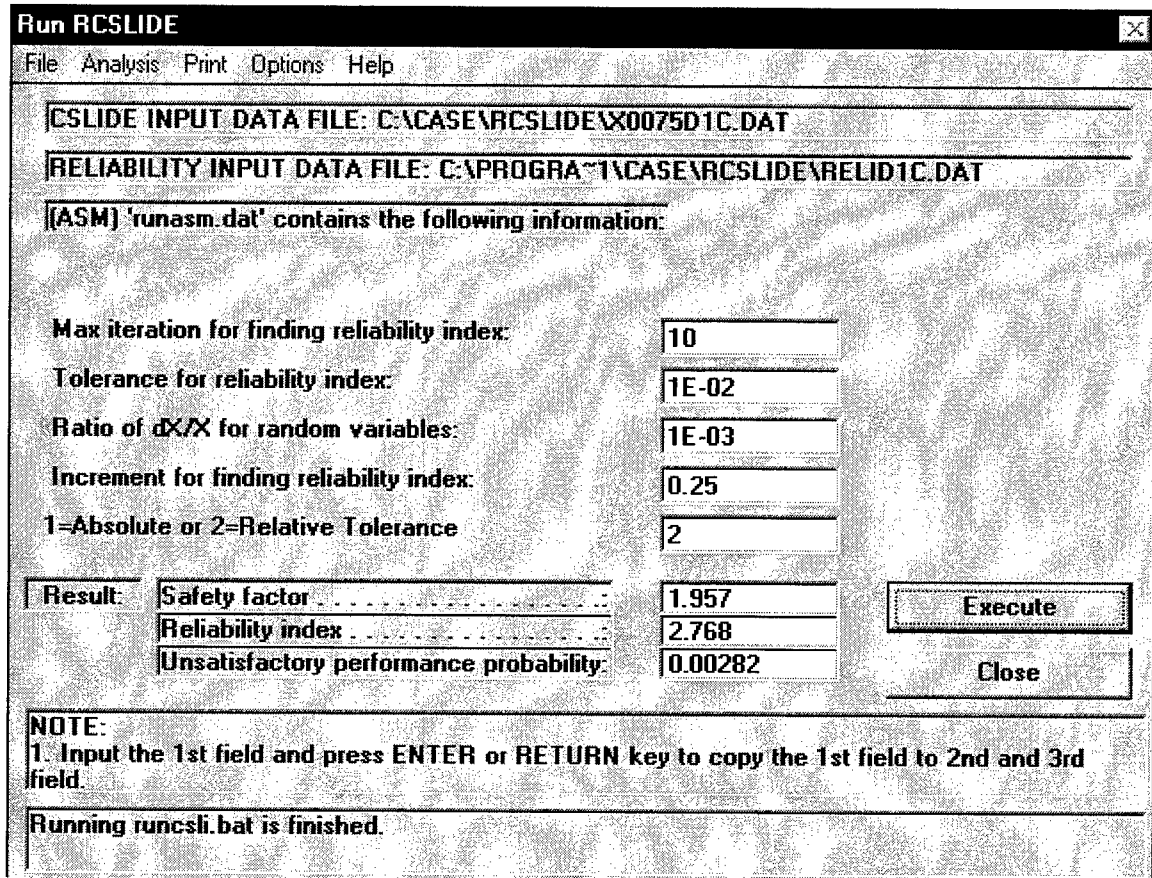

Figure C14. Problem 1C factor of safety – ASM method

Three output files are generated when the Run ASM Analysis option is selected.

- a. CSLIDE analysis output file (*.out).
- b. Detailed ASM reliability assessment output file (*.oas).
- c. Compact ASM reliability assessment output file (*.ras).

These files can be saved by selecting **File** on the menu bar, then **Save Analysis As** (Figure C15). The dialog box shown in Figure C16 will be displayed for entering the root filenames to be used when saving the output and input files.

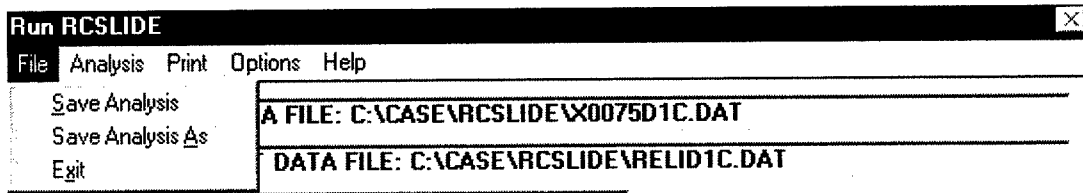

Figure C15. Run CSLIDE File pull-down menu

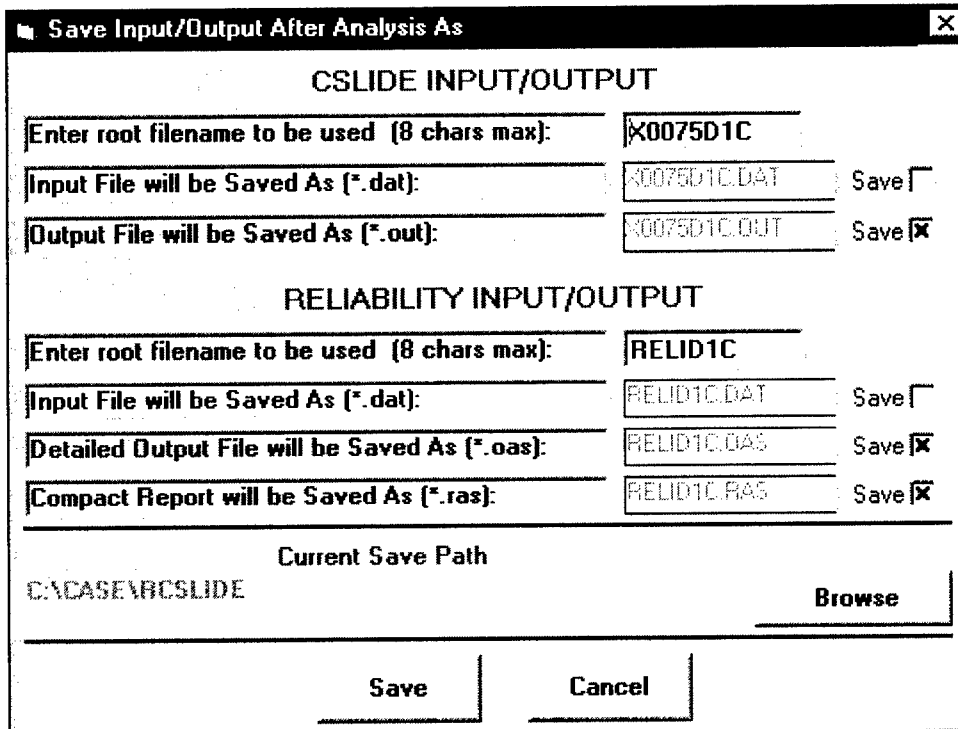

Figure C16. Save input/output dialog box

RC SLIDE module output

Review output file. To review the output file, select **Output** (Figure C17) from the **View** menu on the main window.

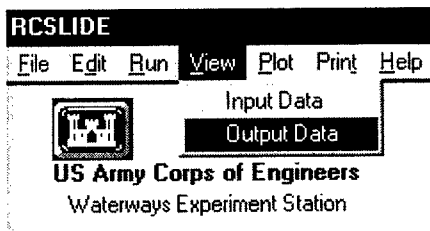

Figure C17. View menu

Enter name of output file to review or select an output file to review from the Figure C18 window.

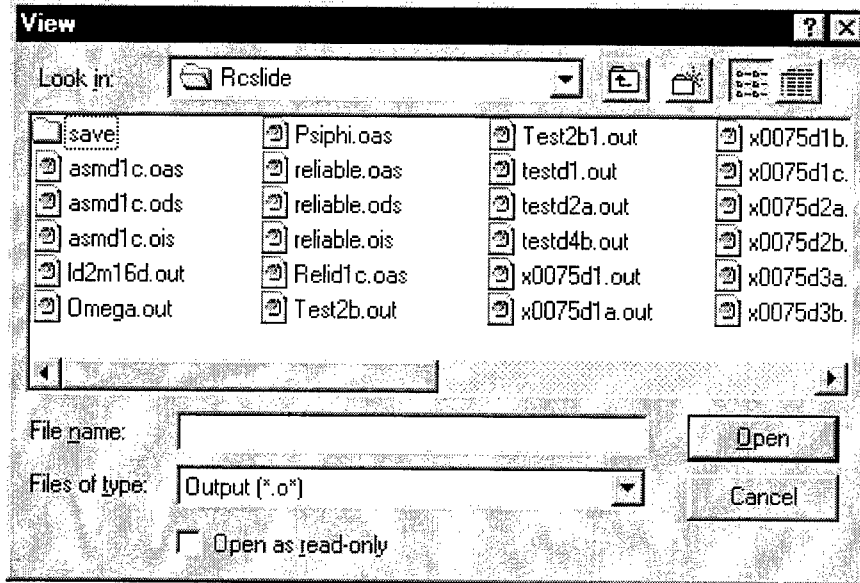

Figure C18. RC SLIDE output filename

Once a file to be viewed is selected, it will be displayed in a view window (Figure C19). Use the scroll bar on the viewport to view the entire file.

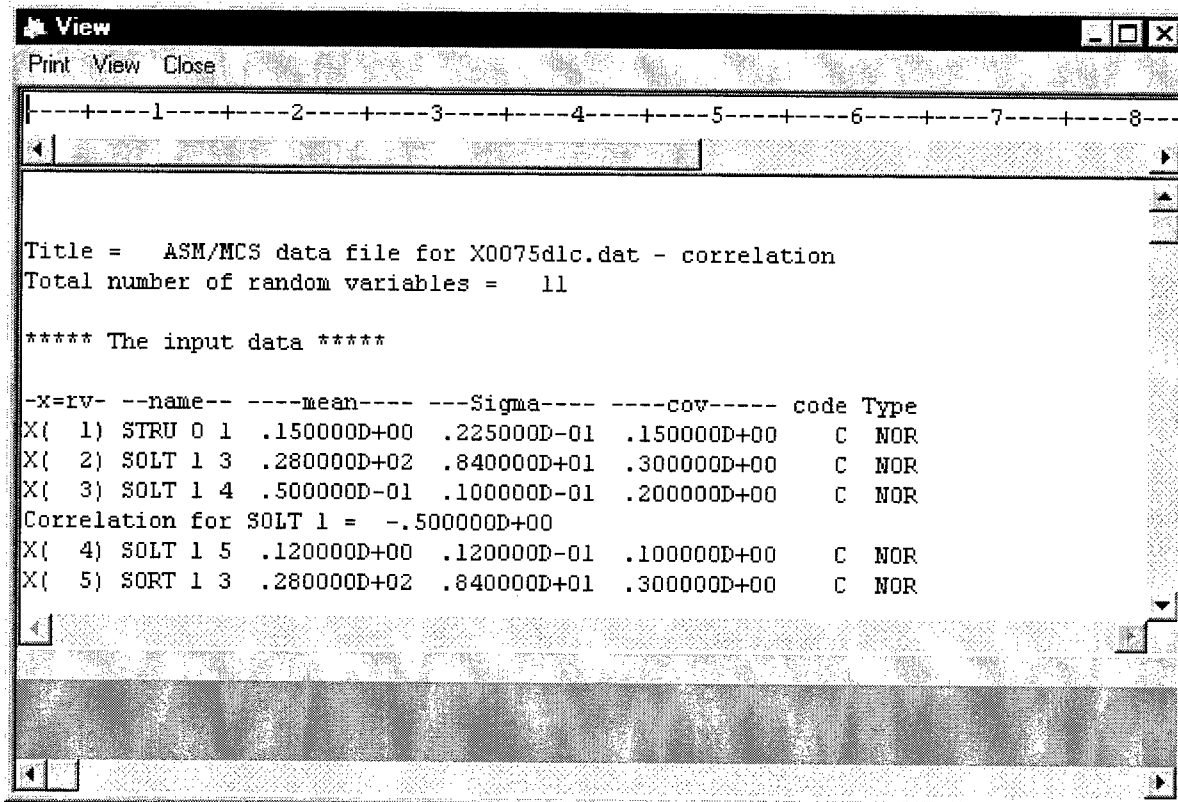

Figure C19. Review of Output file from ASM analysis

Select **Print**, then **File** from the View screen in order to produce a hard copy of the analysis result, such as the following file.

CSLIDE Analysis Output File: X0075D1C.out

PROGRAM CSLIDE - ECHOPRINT

DATE: 03-MAY-1999

TIME: 08.50.08

PROBLEM 1C - RETAINING WALL WITH CORRELATION

SINGLE FAILURE PLANE ANALYSIS

SEEPAGE FORCE BY LINE OF CREEP, GRADIENT
COMPUTED USING SHORTEST SEEPAGE PATH.

NO OF CORNERS IN STRUCTURE -----	8
DENSITY OF CONCRETE -----	.1500 (KCF)
DENSITY OF WATER -----	.0625 (KCF)
WATER LEVEL LEFT SIDE -----	5.00 (FT)
WATER LEVEL RIGHT SIDE -----	1.00 (FT)
NO. OF SOIL LAYERS LEFT SIDE -----	1
NO. OF SOIL LAYERS RIGHT SIDE -----	1

ELEV. OF WEDGE-STRUCTURE INTERSECTION ON ACTIVE SIDE OF STRUCTURE -----	.000 (FT)
--	-----------

STRUCTURE INFORMATION

POINT	X-COORD	Y-COORD
-----	-----	-----
1	.00	.00
2	.00	2.00
3	6.00	2.00
4	6.00	14.00
5	8.00	14.00
6	8.00	2.00
7	12.00	2.00
8	12.00	.00

LEFT-SIDE SOIL DATA

LAYER NO.	FRICITION ANGLE (DEG)	COHESION (KSF)	UNIT WEIGHT (KCF)	ELEV AT STRUCTURE (FT)
1	28.00	.0500	.120	14.00

LAYER NO	POINT NO. 1 X-COORD	Y-COORD
1	-500.00	14.00

SOIL DATA BELOW STRUCTURE

FRICITION ANGLE ----- 30.00
 COHESION ----- .0500

RIGHT-SIDE SOIL DATA

LAYER NO.	FRICITION ANGLE (DEG)	COHESION (KSF)	UNIT WEIGHT (KCF)	ELEV AT STRUCTURE (FT)
1	28.00	.0500	.120	4.00

LAYER NO	POINT NO. 1 X-COORD	Y-COORD
1	500.00	4.00

PROGRAM CSLIDE - FINAL RESULTS

DATE: 03-MAY-1999

TIME: 08.50.08

PROBLEM 1C - RETAINING WALL WITH CORRELATION

SINGLE FAILURE PLANE ANALYSIS

SEEPAGE FORCE COMPUTED BY LINE OF CREEP

WEDGE NUMBER	HORIZONTAL LOADS		VERTICAL LOAD (KIPS)
	LEFT SIDE (KIPS)	RIGHT SIDE (KIPS)	
1	.000	.000	.000
2	.000	.000	9.600
3	.000	.000	.000

WATER PRESSURES ON WEDGES

LEFT-SIDE WEDGES

WEDGE NO.	TOP PRESSURE (KSF)	BOTTOM PRESSURE (KSF)
1	.000	.243

STRUCTURAL WEDGE

X-COORD. (FT)	PRESSURE (KSF)
.00	.243
12.00	.076

RIGHT-SIDE WEDGES

WEDGE NO.	TOP PRESSURE (KSF)	BOTTOM PRESSURE (KSF)
3	.000	.076

WEDGE NUMBER	FAILURE ANGLE (DEG)	TOTAL LENGTH (FT)	WEIGHT OF WEDGE (KIPS)	SUBMERGED LENGTH (FT)	UPLIFT FORCE (KIPS)
1	-52.595	17.624	8.993	6.294	.765
2	.000	12.000	7.200	12.000	1.917
3	37.411	6.584	1.255	1.646	.063

WEDGE NUMBER	NET FORCE ON WEDGE (KIPS)
1	-6.580
2	4.698
3	1.883
SUM OF FORCES ON SYSTEM ----- .000	
FACTOR OF SAFETY ----- 1.957	

Failure Surface plot. Figure C20 depicts a plot of the failure surface for the problem as computed by the CSLIDE analysis.

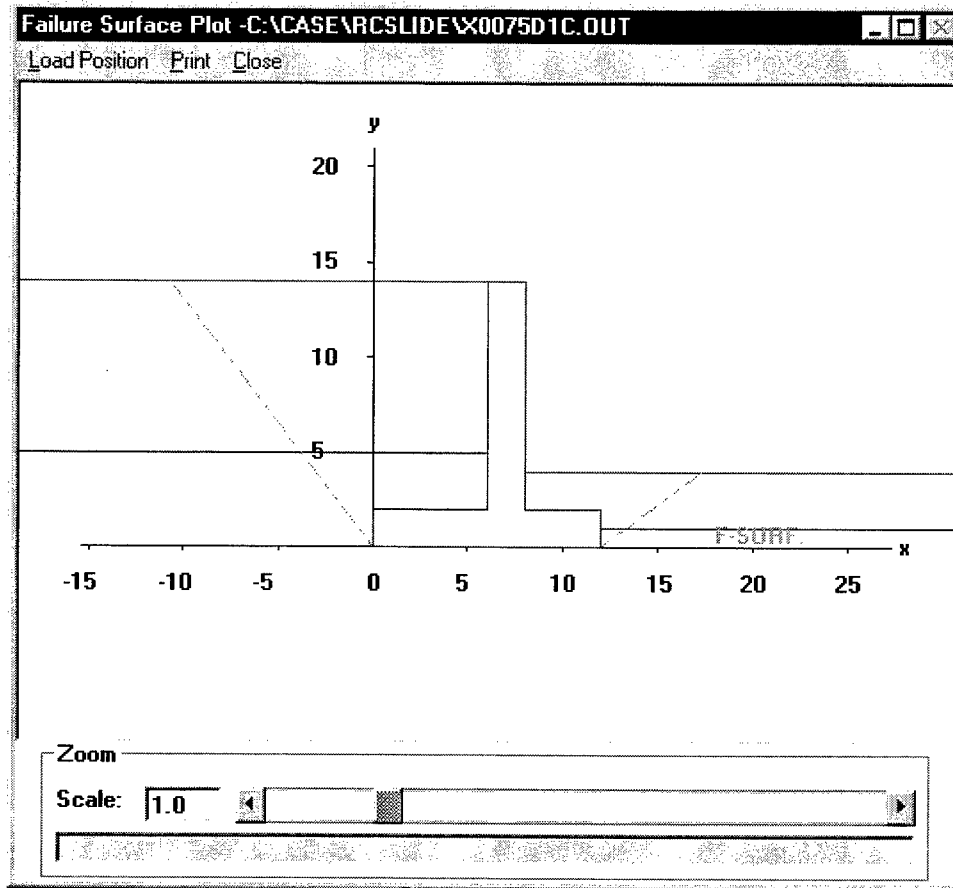

Figure C20. Failure Surface plot – Problem 1C

Wedge plots. Figures C21 through C23 display plots of each wedge generated by the CSLIDE analysis.

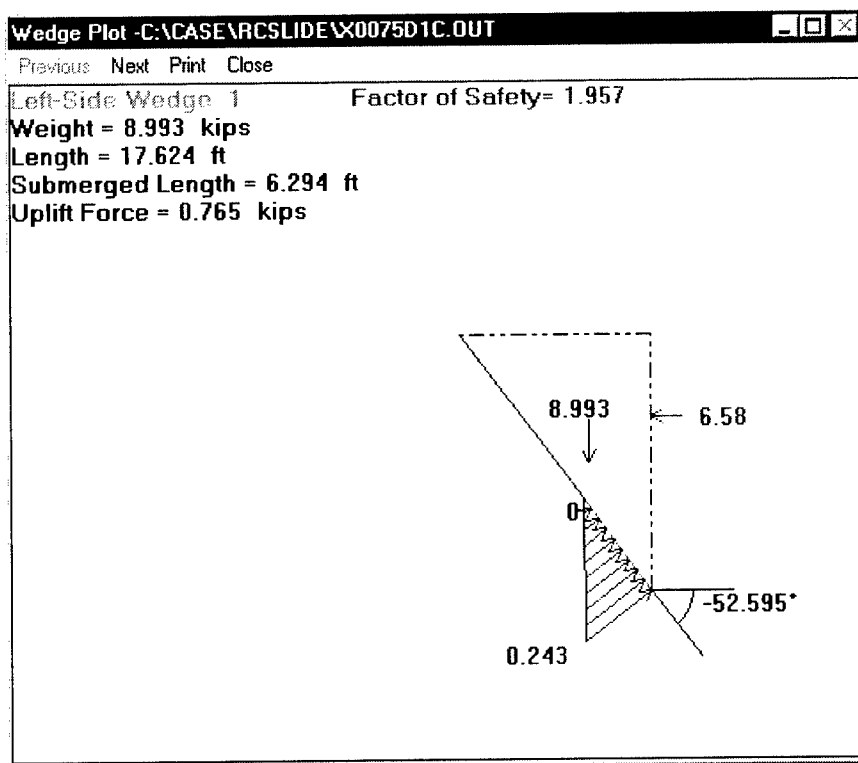

Figure C21. Left-side wedge – Problem 1C

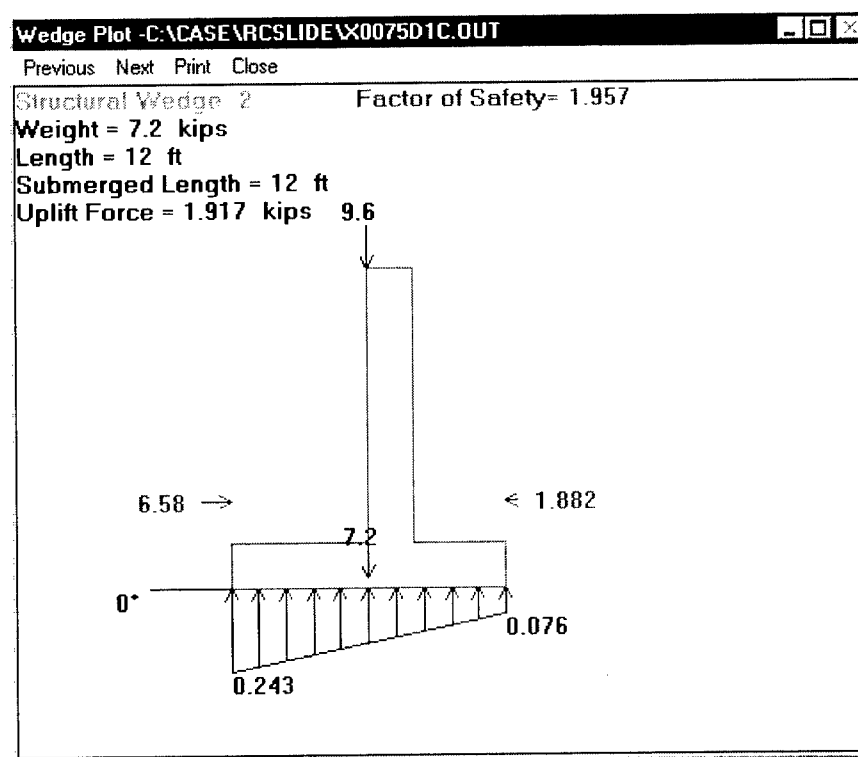

Figure C22. Structural wedge – Problem 1C

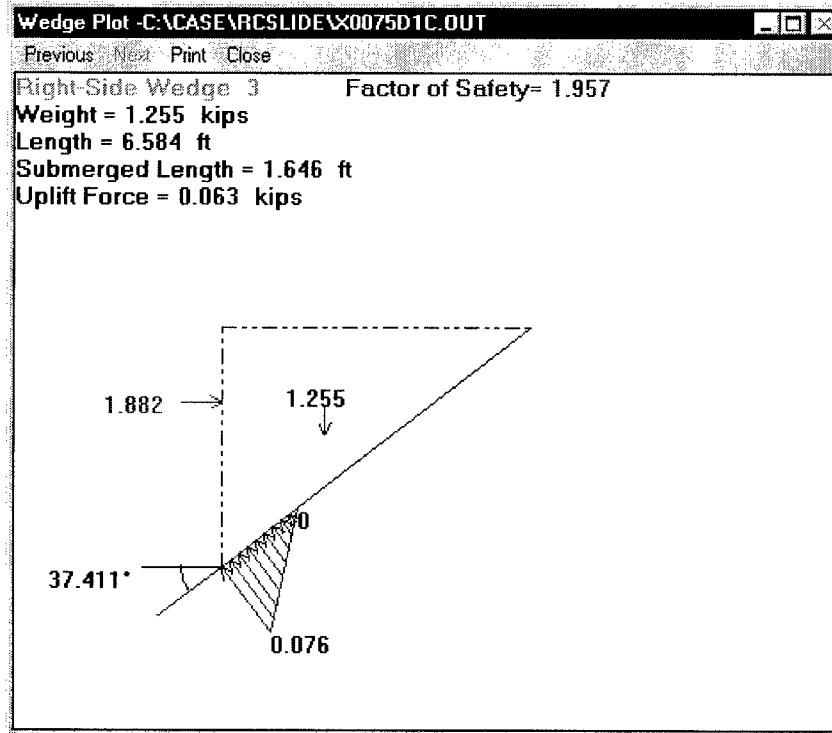

Figure C23. Right-side wedge – Problem 1C

Report File (Compact) from the ASM Method: RELID1C.ras

Title = ASM/MCS data file for X0075dlc.dat - correlation

Total number of random variables = 11

***** The input data *****

-x=rv-	--name--	----	mean----	---Sigma---	-----cov-----	code	Type
X(1)	STRU 0 1		.150000D+00	.225000D-01	.150000D+00	C	NOR
X(2)	SOLT 1 3		.280000D+02	.840000D+01	.300000D+00	C	NOR
X(3)	SOLT 1 4		.500000D-01	.100000D-01	.200000D+00	C	NOR
Correlation for SOLT 1 = -.500000D+00							
X(4)	SOLT 1 5		.120000D+00	.120000D-01	.100000D+00	C	NOR
X(5)	SORT 1 3		.280000D+02	.840000D+01	.300000D+00	C	NOR
X(6)	SORT 1 4		.500000D-01	.100000D-01	.200000D+00	C	NOR
Correlation for SORT 1 = -.500000D+00							
X(7)	SORT 1 5		.120000D+00	.120000D-01	.100000D+00	C	NOR
X(8)	SOST 0 3		.300000D+02	.900000D+01	.300000D+00	C	NOR
X(9)	SOST 0 4		.500000D-01	.500000D-02	.100000D+00	C	NOR
Correlation for SOST 0 = -.500000D+00							
X(10)	WATR 0 1		.500000D+01	.100000D+01	.200000D+00	S	NOR
X(11)	WATR 0 2		.100000D+01	.100000D+01	.100000D+01	S	NOR

The tolerance of reliability index (beta) = .100000D-01
 The ratio of dx/x for random variables = .100000D-02
 The max. iterations for finding beta = 10
 The increment for finding beta = .2500
 The 1=absolute 2=relative tolerance for beta = 2

The limit state $Z=R-L=L(SF-1)$ or $Z=SF-1$

***** The result *****

The iteration No. = 1

-i	---meanEN---	----stdEN---	---alpha----	-----dp-----	-Partial.SF-
1	.150000D+00	.225000D-01	.155236D+00	.140313D+00	.935417D+00
2	.280000D+02	.840000D+01	.308990D+00	.154658D+02	.552350D+00
3	.500000D-01	.100000D-01	.442832D+00	.563517D-01	.112703D+01
4	.120000D+00	.120000D-01	-.210823D+00	.127017D+00	.105847D+01
5	.280000D+02	.840000D+01	.903259D-01	.247013D+02	.882188D+00
6	.500000D-01	.100000D-01	.111343D+00	.514218D-01	.102844D+01
7	.120000D+00	.120000D-01	.938508D-01	.116876D+00	.973970D+00
8	.300000D+02	.900000D+01	.395575D+00	.108111D+02	.360369D+00
9	.500000D-01	.500000D-02	.659264D+00	.551748D-01	.110350D+01
10	.500000D+01	.100000D+01	-.754490D-01	.520926D+01	.104185D+01
11	.100000D+01	.100000D+01	-.117116D+00	.132483D+01	.132483D+01

The reliability index (beta) = .277355D+01

The iteration No. = 2

-i	---meanEN---	----stdEN---	---alpha----	-----dp-----	-Partial.SF-
1	.150000D+00	.225000D-01	.671604D-01	.145817D+00	.972111D+00
2	.280000D+02	.840000D+01	.326601D+00	.151911D+02	.542539D+00
3	.500000D-01	.100000D-01	.447451D+00	.562069D-01	.112414D+01
4	.120000D+00	.120000D-01	-.207552D+00	.126895D+00	.105746D+01
5	.280000D+02	.840000D+01	.180568D+00	.207023D+02	.739369D+00
6	.500000D-01	.100000D-01	.258107D+00	.536888D-01	.107378D+01
7	.120000D+00	.120000D-01	.105876D+00	.116483D+00	.970689D+00
8	.300000D+02	.900000D+01	.375751D+00	.118528D+02	.395092D+00
9	.500000D-01	.500000D-02	.624071D+00	.548806D-01	.109761D+01
10	.500000D+01	.100000D+01	-.383589D-01	.510619D+01	.102124D+01
11	.100000D+01	.100000D+01	-.545221D-01	.115094D+01	.115094D+01

The reliability index (beta) = .276844D+01

The unsatisfactory performance probability = .281623D-02

Problem 2

The purpose of this example problem is to demonstrate performing a reliability assessment using the simulation methods in RCLIDE. A cross section of monolith M-16 of Lock and Dam No. 2 on the Monongahala River is depicted in Figure C24. M-16 is a shale-founded gravity monolith forming part of the middle wall between the two lock chambers and is subjected to horizontal soil and water loads. Two openings, a filling and emptying culvert and a pipe gallery, are present in the monolith. The structure is founded at elevation 672.0, about 2.5 ft below the top of the shale. Soil backfill extends to elevation 690.5 on both sides of the monolith and is covered by a 1.0-ft concrete fill forming the chamber floor at elevation 691.5. Being a middle-wall monolith, the upper pool (EL 718.7 during maintenance) acts on one side and the lower pool (EL 691.5 during maintenance) on the other. The mean and standard deviation of the random variables based on actual data, experience, or engineering judgment are given below:

<u>Variable</u>	<u>μ</u>	<u>σ</u>
γ_{soil}	0.0755 kcf	0.003775
ϕ_{soil}	33 deg	3.3
c_{rock}	11 ksf	0.77
ϕ_{rock}	56.31 deg	13.
γ_{concrete}	0.15 kcf	0.075

The correlation coefficient between c and ϕ is -0.70 . Seepage pressures are calculated using hydrostatic pressures with an uplift force of 92.1 kips. A complete description of this problem can be found in Wolff and Wang (1992).¹

This example problem shows the results of a reliability assessment by using the CSLIDE input file "ld2m16d.dat" and the reliability data file "Reliable.dat".

Part 2A. Determine the sliding factor of safety from a CSLIDE analysis.

Part 2B. Determine the probability of unsatisfactory performance for the monolith under sliding conditions using the direct Monte Carlo simulation method for reliability assessment.

Part 2C. Determine the probability of unsatisfactory performance for the monolith under sliding conditions using simulation with importance sampling.

¹ References cited in this appendix are listed in the References at the end of the main text.

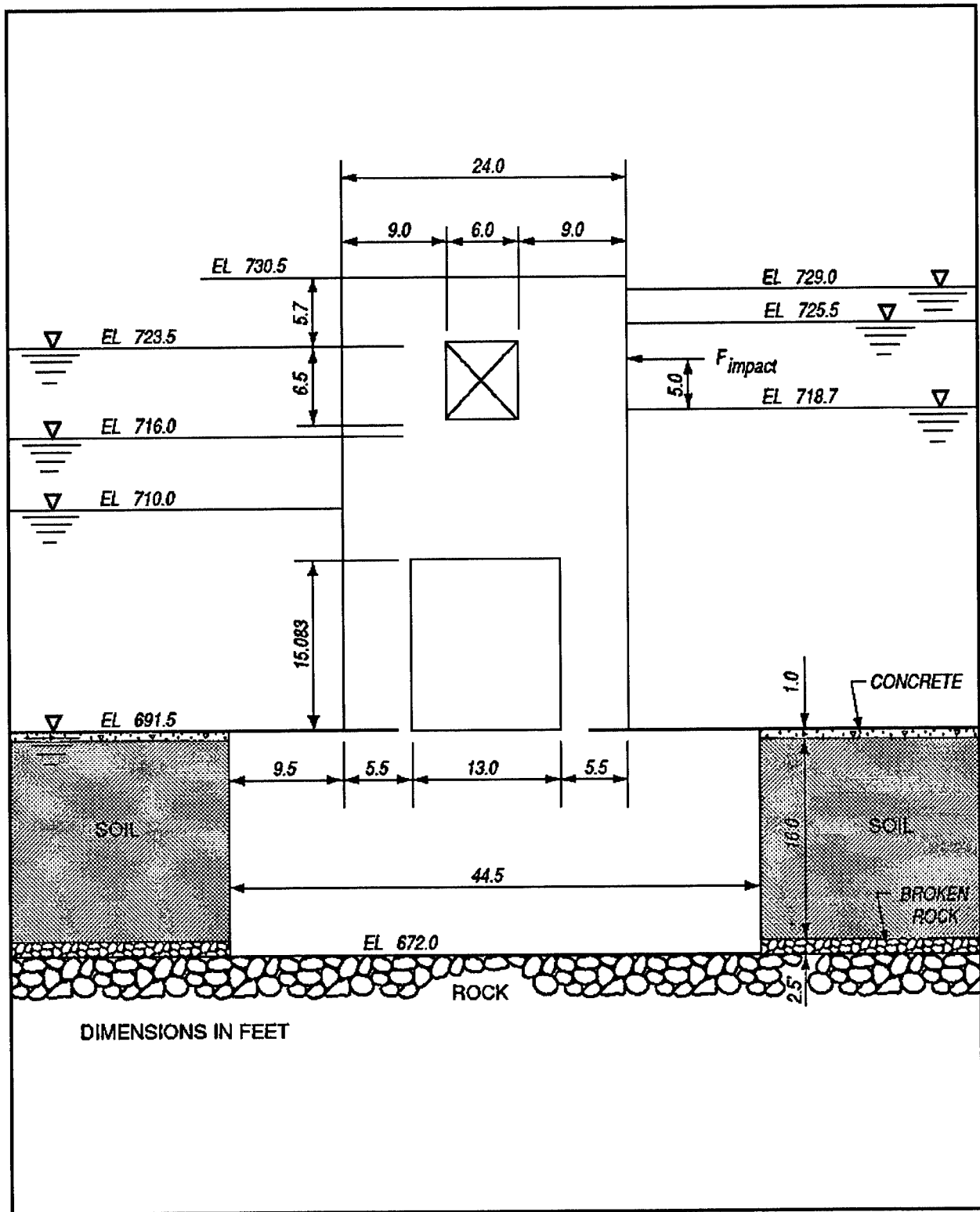

Figure C24. Lock and Dam No. 2, Monolith M16, cross section

Problem 2A

Input CSLIDE File, LD2M16D.dat

```
001 TITL L & D #2 M16 STABILITY ANALYSIS
002 TITL Max. Shear Strength
003 TITL
004 TITL
005 STRU 8 0.15 0.0 1.0
006 0.00 0.00
007 0.00 19.50
008 9.50 19.50
009 9.50 58.50
010 33.50 58.50
011 33.50 19.50
012 44.50 19.50
013 44.50 0.00
014 SOLT 1 1 33.0 0.0 0.0755 19.5
015 -500.00 19.50
016 SOLT 2 1 33.0 0.0 0.063 2.5
017 -500.00 2.50
018 SORT 1 1 33.0 0.0 0.0755 19.5
019 500.00 19.50
020 SORT 2 1 33.0 0.0 0.063 2.5
021 500.00 2.50
022 SOST 56.31 11.0
023 METH 1
024 WATR 46.7 19.5 0.0625 0 92.1
025 FACT 0.5000 1.5000 1.0000
026 END
```

An uplift force of 92.1 kips can be entered on the **Water Description** screen, item 5, as shown in Figure C25. For this problem, seepage pressures are computed for hydrostatic conditions.

RC SLIDE: Water Description [X]

Uplift Force Print Help

Uplift force: Seepage Option

	a. Mean	b. Stddv/COV	c. Code	d. Distribution
1. Left-side water elevation (ft):	46.7	0	C	NOR
2. Right-side water elevation (ft):	19.5	0	C	NOR
3. Unit weight of water (kcf):	0.0625			
4. Seepage (-1, 0, 1):	0=Hydrostatic			
5. Uplift force (kips):	92.1	0	C	NOR

Ok Cancel

Figure C25. Water description screen

To obtain a plot of the monolith, select **Plot**, then **Structure** from the main menu bar, and Figure C26 will be displayed.

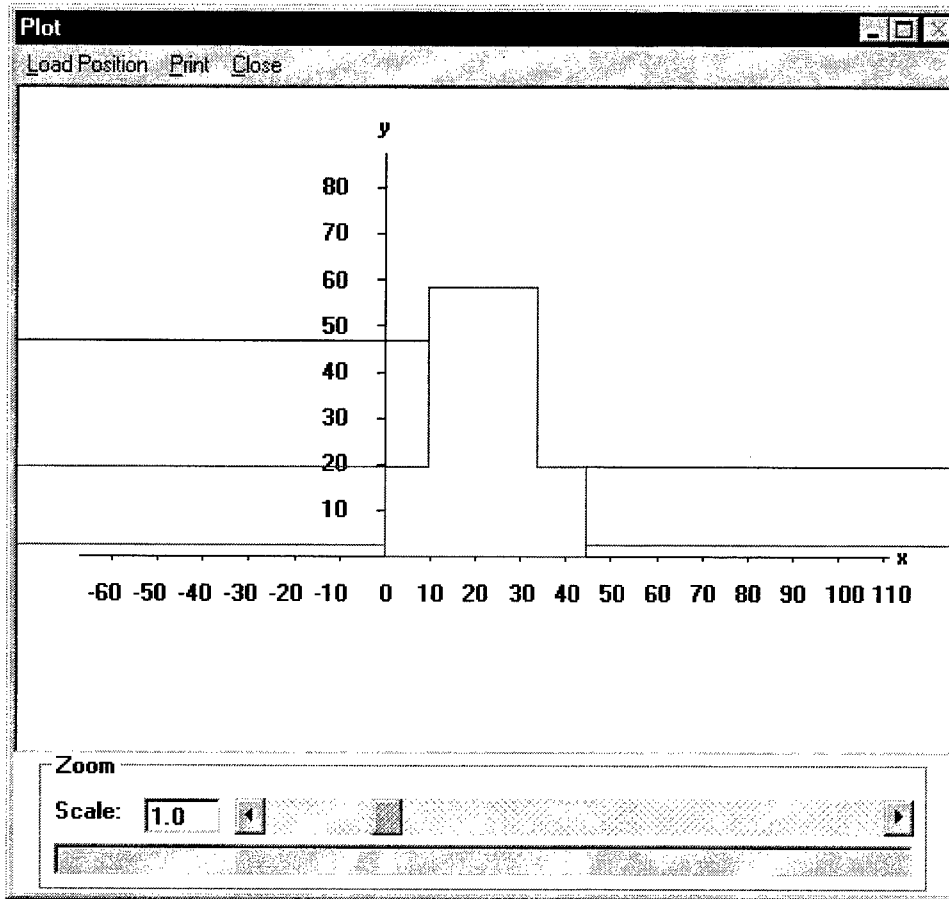

Figure C26. Plot of input structure

Problem 2A output

Factor of safety. The screen displaying the factor of safety for Monolith M-16 of Lock and Dam No. 2 is shown in Figure C27.

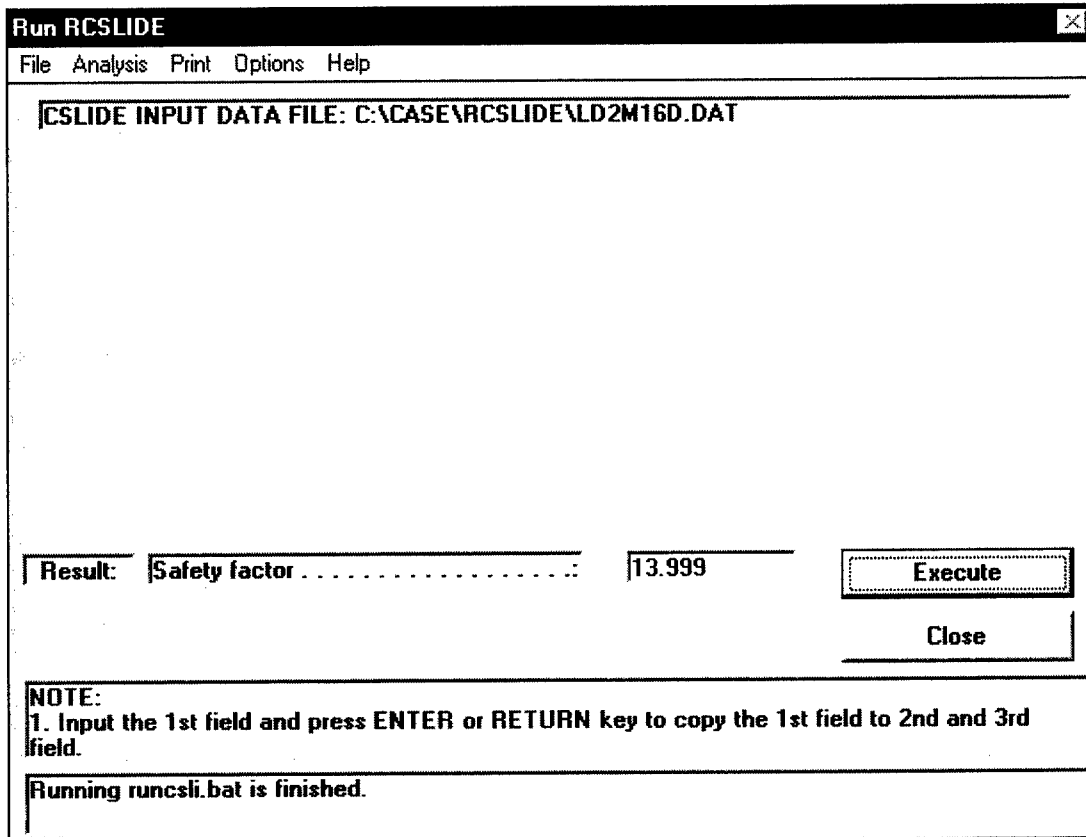

Figure C27. Problem 2A factor of safety

CSLIDE Analysis Output File: LD2M16D.out

```

-----
PROGRAM CSLIDE - ECHOPRINT
-----

DATE: 03-MAY-1999                TIME: 09.39.31

L & D #2 M16 STABILITY ANALYSIS

MAX. SHEAR STRENGTH

SINGLE FAILURE PLANE ANALYSIS

HYDROSTATIC WATER FORCE COMPUTED FOR WEDGES

NO OF CORNERS IN STRUCTURE ----- 8
DENSITY OF CONCRETE ----- .1500 (KCF)
DENSITY OF WATER ----- .0625 (KCF)
WATER LEVEL LEFT SIDE ----- 46.70 (FT)
WATER LEVEL RIGHT SIDE ----- 19.50 (FT)
NO. OF SOIL LAYERS LEFT SIDE ----- 2
NO. OF SOIL LAYERS RIGHT SIDE ----- 2

```

ELEV. OF WEDGE-STRUCTURE INTERSECTION
 ON ACTIVE SIDE OF STRUCTURE ----- .000 (FT)

UPLIFT FORCE AT BASE OF STRUCTURE --- 92.100 (KIPS)

STRUCTURE INFORMATION

POINT -----	X-COORD -----	Y-COORD -----
1	.00	.00
2	.00	19.50
3	9.50	19.50
4	9.50	58.50
5	33.50	58.50
6	33.50	19.50
7	44.50	19.50
8	44.50	.00

LEFT-SIDE SOIL DATA

LAYER NO.	FRICITION ANGLE (DEG)	COHESION (KSF)	UNIT WEIGHT (KCF)	ELEV AT STRUCTURE (FT)
1	33.00	.0000	.075	19.50
2	33.00	.0000	.063	2.50

LAYER NO	POINT NO. 1 X-COORD	Y-COORD
1	-500.00	19.50
2	-500.00	2.50

SOIL DATA BELOW STRUCTURE

FRICITION ANGLE ----- 56.31
 COHESION ----- 11.0000

RIGHT-SIDE SOIL DATA

LAYER NO.	FRICTION ANGLE (DEG)	COHESION (KSF)	UNIT WEIGHT (KCF)	ELEV AT STRUCTURE (FT)
1	33.00	.0000	.075	19.50
2	33.00	.0000	.063	2.50

LAYER NO	POINT NO. 1 X-COORD	Y-COORD
1	500.00	19.50
2	500.00	2.50

PROGRAM CSLIDE - FINAL RESULTS

DATE: 03-MAY-1999

TIME: 09.39.31

L & D #2 M16 STABILITY ANALYSIS

MAX. SHEAR STRENGTH

SINGLE FAILURE PLANE ANALYSIS

HYDROSTATIC WATER FORCE COMPUTED FOR WEDGES

WEDGE NUMBER	HORIZONTAL LOADS		VERTICAL LOAD (KIPS)
	LEFT SIDE (KIPS)	RIGHT SIDE (KIPS)	
1	.000	.000	27.674
2	.000	.000	4.070
3	23.120	.000	16.150
4	.000	.000	.000
5	.000	.000	.000

WATER PRESSURES ON WEDGES

LEFT-SIDE WEDGES

WEDGE NO.	TOP PRESSURE (KSF)	BOTTOM PRESSURE (KSF)
1	1.700	2.763
2	2.763	2.919

UPLIFT FORCE ON
STRUCTURAL WEDGE
(KIPS)

92.100

RIGHT-SIDE WEDGES

WEDGE NO.	TOP PRESSURE (KSF)	BOTTOM PRESSURE (KSF)
4	1.063	1.219
5	.000	1.063

WEDGE NUMBER	FAILURE ANGLE (DEG)	TOTAL LENGTH (FT)	WEIGHT OF WEDGE (KIPS)	SUBMERGED LENGTH (FT)	UPLIFT FORCE (KIPS)
1	-46.242	23.537	10.447	23.537	52.517
2	-46.242	3.461	3.261	3.461	9.832
3	.000	44.500	270.563	44.500	92.100
4	43.731	3.617	3.560	3.617	4.125
5	43.731	24.592	11.404	24.592	13.065

WEDGE
NUMBER

NET FORCE
ON WEDGE
(KIPS)

1	-39.643
2	-7.607
3	32.698
4	3.459
5	11.092

SUM OF FORCES ON SYSTEM ----	.000
FACTOR OF SAFETY -----	13.999

Structure plot (Figure C28).

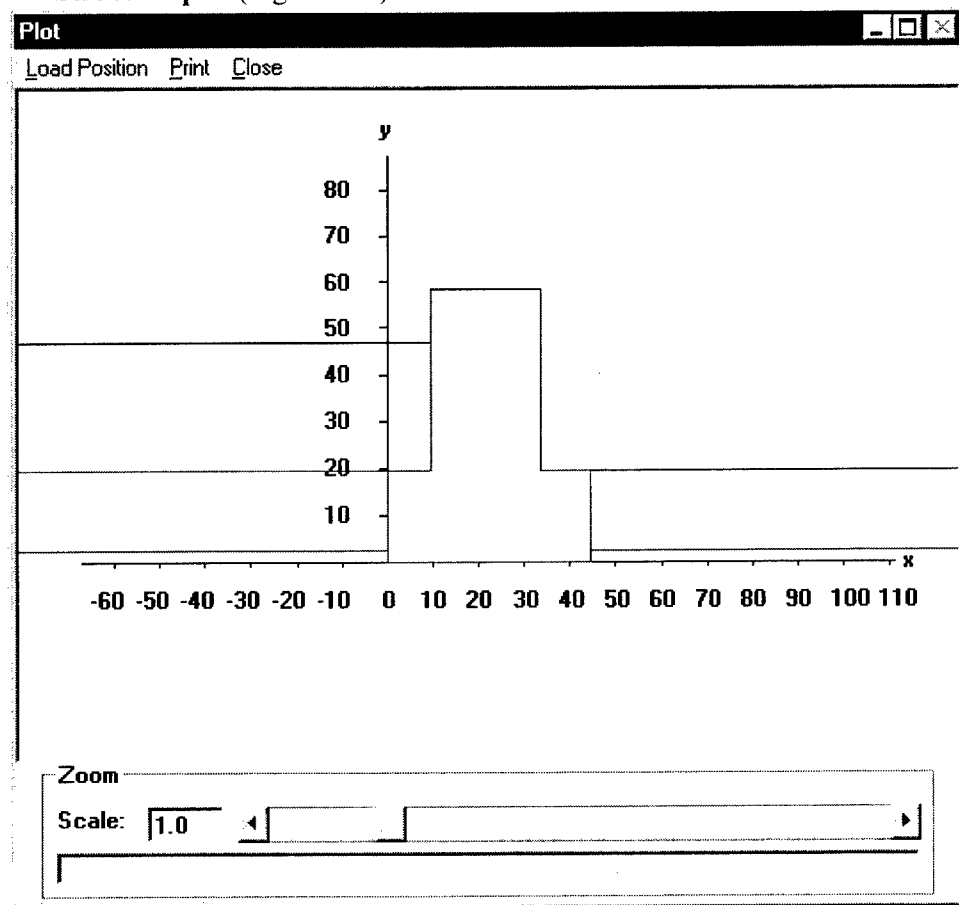

Figure C28. Structure plot – Problem 2A

Failure Surface plot (Figure C29).

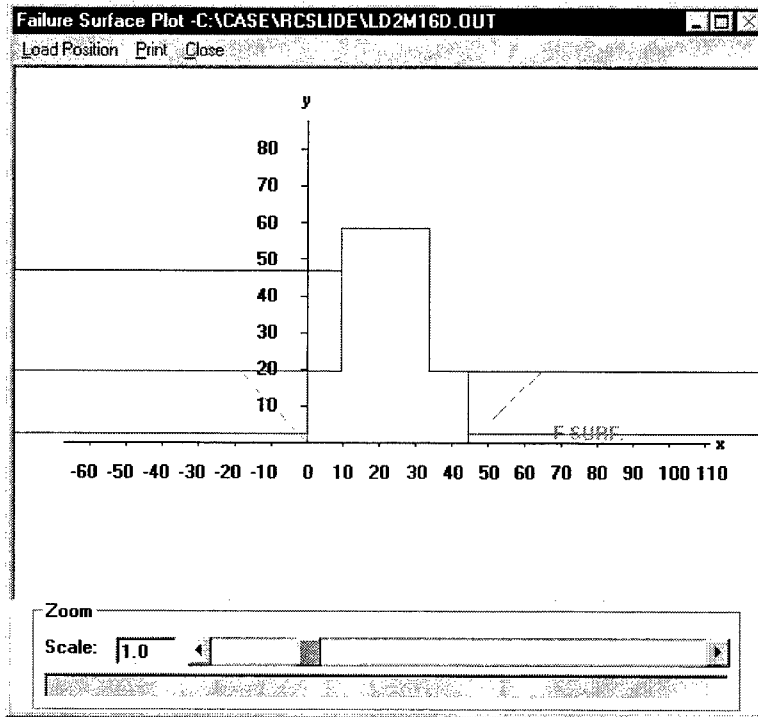

Figure C29. Failure Surface plot – Problem 2A

Wedge plots (Figures C30-C34).

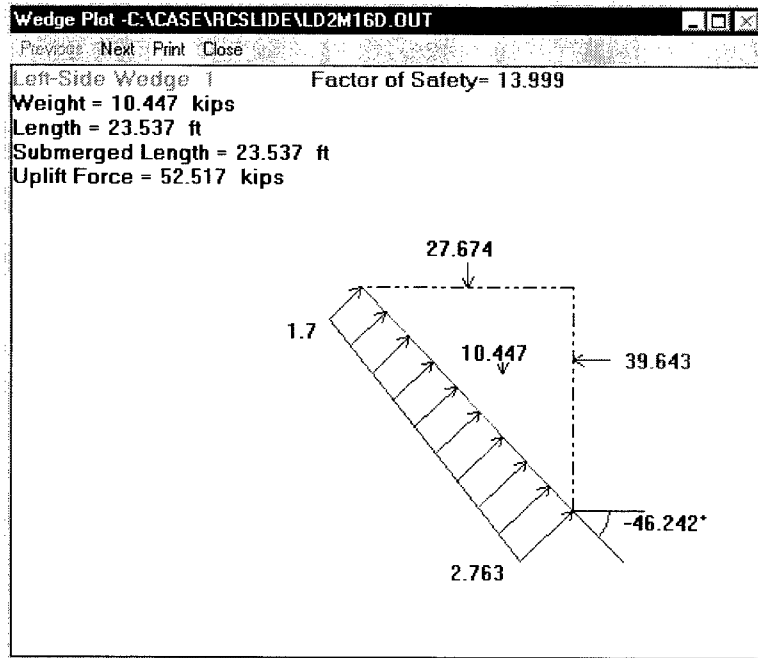

Figure C30. Left-side Wedge 1 Problem 2A

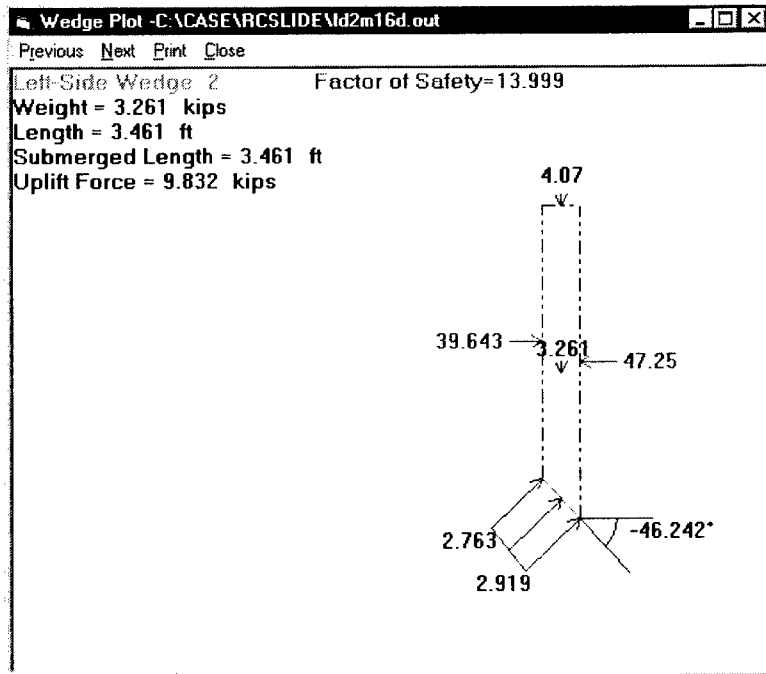

Figure C31. Left-side Wedge 2 Problem 2A

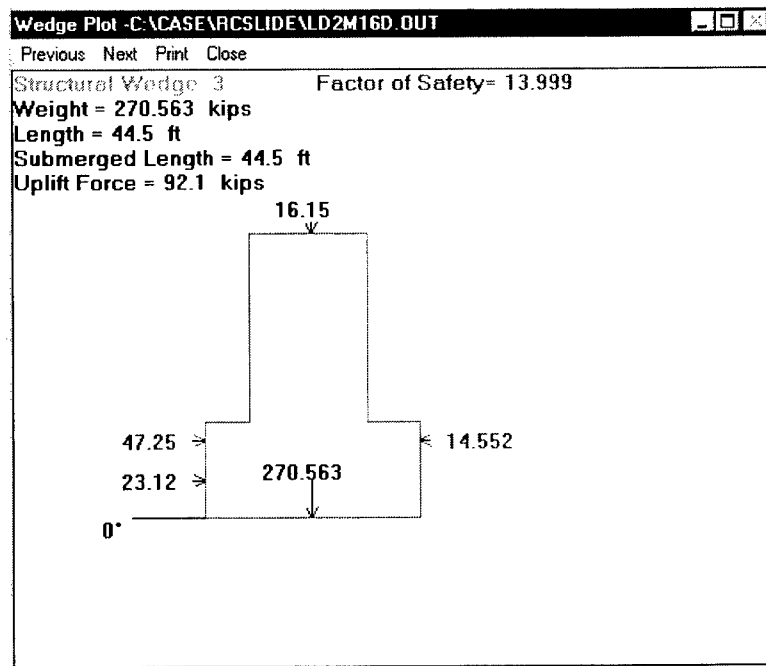

Figure C32. Structural Wedge 3 Problem 2A

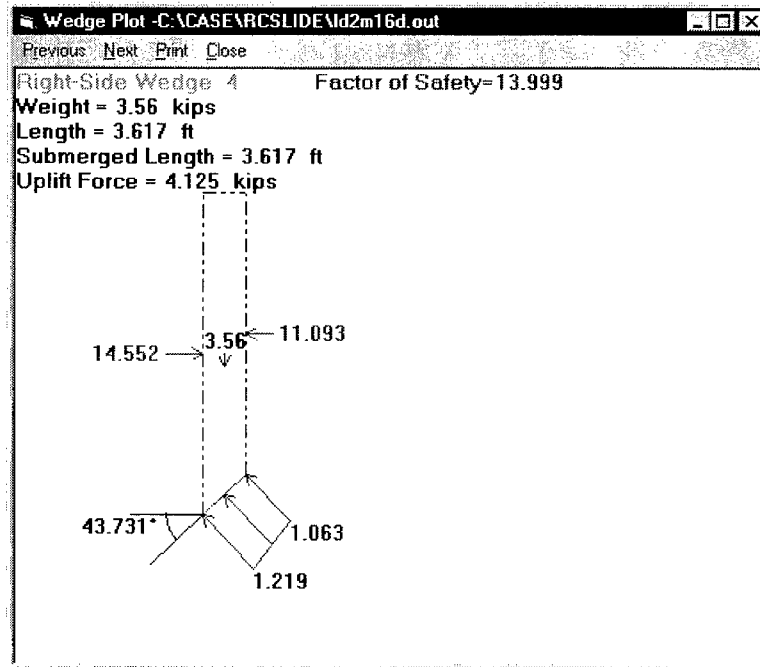

Figure C33. Right-side Wedge 4 Problem 2A

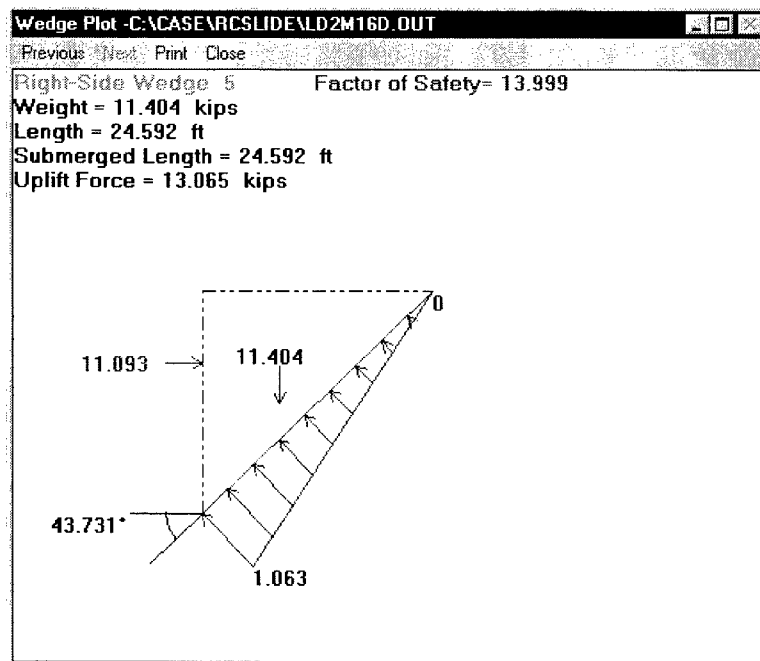

Figure C34. Right-side Wedge 5 Problem 2A

Problem 2B

In this problem, RCSLIDE uses the direct Monte Carlo simulation method of reliability analysis in conjunction with the CSLIDE data referred to in Problem 2A.

Input CSLIDE File: LD2M16D.dat

This file is the one used in Problem 2A previously in this appendix.

Input Reliability File: RELIABLE.dat

```
TITL
STRU0001 1.500000E-01 7.500000E-03 S NOR
SOLT0103 3.300000E+01 3.300000E+00 S NOR
SOLT0105 7.550000E-02 3.775000E-03 S NOR
SORT0103 3.300000E+01 3.300000E+00 S NOR
SORT0105 7.550000E-02 3.775000E-03 S NOR
SOST0003 5.631000E+01 1.300000E+01 S NOR
SOST0004 1.100000E+01 7.700000E-01 S NOR -6.900000E-01
END
```

Problem 2B output

The reliability index and probability of unsatisfactory performance for the monolith under sliding conditions using the direct Monte Carlo simulation method for reliability assessment is given in Figure C35, which is followed by a listing of the output file.

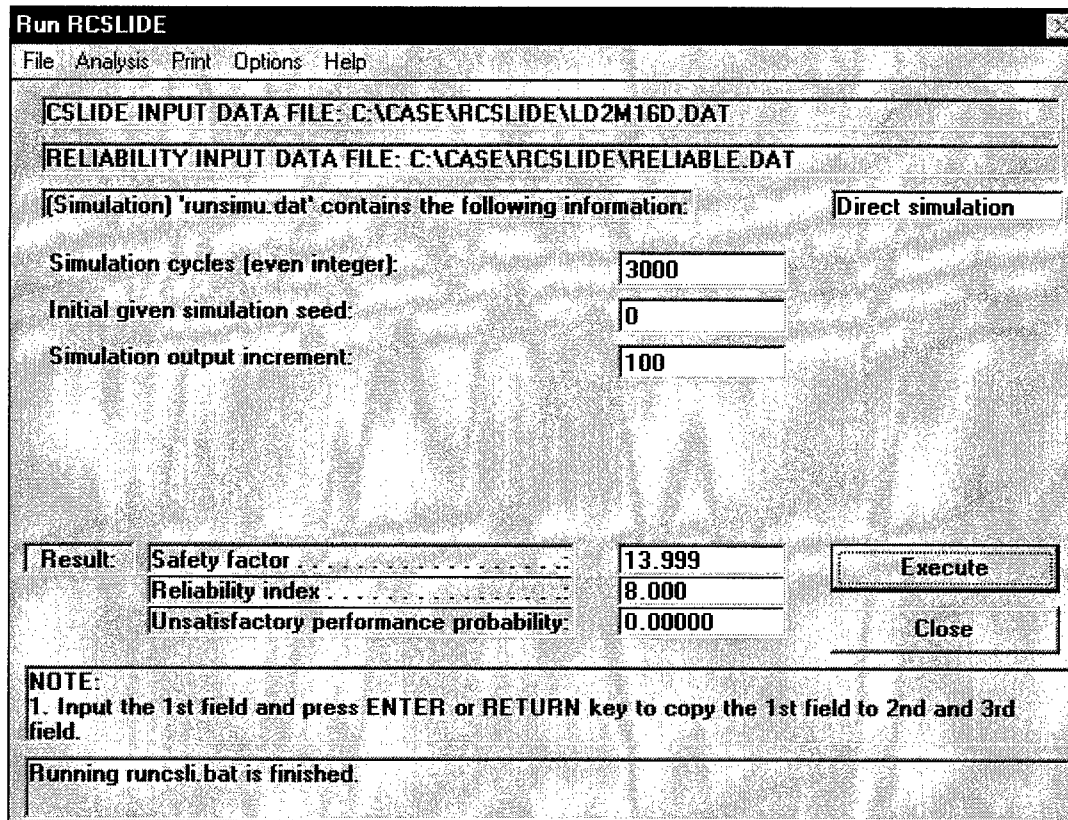

Figure C35. Probability of unsatisfactory performance – direct simulation

There are two output files generated by executing the **Analysis** option **Run SIMU-Direct Simulation**, a CSLIDE analysis output file and the output from the reliability assessment. These can be saved as shown in Problem 1 of this appendix.

Output File Listing generated by running the Direct Monte Carlo Simulation method of reliability analysis for Problem 2B: RELIABLE.dat

```
Title =
Total number of random variables = 7
***** The input data *****
-x=rv- --name-- ----mean---- ---Sigma---- ----cov----- code Type
X( 1) STRU 0 1 .150000D+00 .750000D-02 .500000D-01 S NOR
X( 2) SOLT 1 3 .330000D+02 .330000D+01 .100000D+00 S NOR
X( 3) SOLT 1 5 .755000D-01 .377500D-02 .500000D-01 S NOR
X( 4) SORT 1 3 .330000D+02 .330000D+01 .100000D+00 S NOR
X( 5) SORT 1 5 .755000D-01 .377500D-02 .500000D-01 S NOR
X( 6) SOST 0 3 .563100D+02 .130000D+02 .230865D+00 S NOR
X( 7) SOST 0 4 .110000D+02 .770000D+00 .700000D-01 S NOR
Correlation for SOST 0 = -.690000D+00
```

The limit state $Z=R-L=L(SF-1)$ or $Z=SF-1$

The simulation cycle = 3000
The initial given seed = 0
The simulation output increment = 100
The target safety factor = .100000D+01
The safety factor shift ratio = .100000D+00

The safety factor (SF) = .139994E+02

***** The result *****

The initial random seed = -1249403

*** The result of direct simulation ***

```
=====
No.of.cycle- -ave.cum.Pf- -COV(avePf)- B.COV(avePf)
-----
100 .000000E+00
200 .000000E+00
300 .000000E+00
400 .000000E+00
500 .000000E+00
600 .000000E+00
700 .000000E+00
800 .000000E+00
900 .000000E+00
1000 .000000E+00
1100 .000000E+00
1200 .000000E+00
1300 .000000E+00
1400 .000000E+00
1500 .000000E+00
1600 .000000E+00
1700 .000000E+00
1800 .000000E+00
1900 .000000E+00
2000 .000000E+00
2100 .000000E+00
2200 .000000E+00
2300 .000000E+00
2400 .000000E+00
2500 .000000E+00
2600 .000000E+00
2700 .000000E+00
2800 .000000E+00
2900 .000000E+00
3000 .000000E+00
=====
```

The importance failure count = 0

The safety factor > 10 count = 3000

The minimum safety factor = .104177D+02

The maximum safety factor = .151700D+17

The reliability index (beta) = .800000E+01

The binomial statistics
The ave of Pf (AvePf) = .000000D+00
The var of avePf (varAvePf) = .000000D+00
The std of avePf (stdAvePf) = .000000D+00
The cov of avePf (covAvePf) =N/A

The Prog-start time=10:45:41: 78 Date=1999- 3-22
The simu-start time=10:45:42: 4 Date=1999- 3-22
The simu-end time=10:51:41: 3 Date=1999- 3-22
The Prog-end time=10:51:41: 3 Date=1999- 3-22

Plot of simulation curve. To obtain a plot of the probability of unsatisfactory performance at each output iteration cycle, select **Plot** from the main menu bar, then **Simulation Results**. Choose the name of the output file on the plot window (reliable.ods for this problem) to obtain Figure C36.

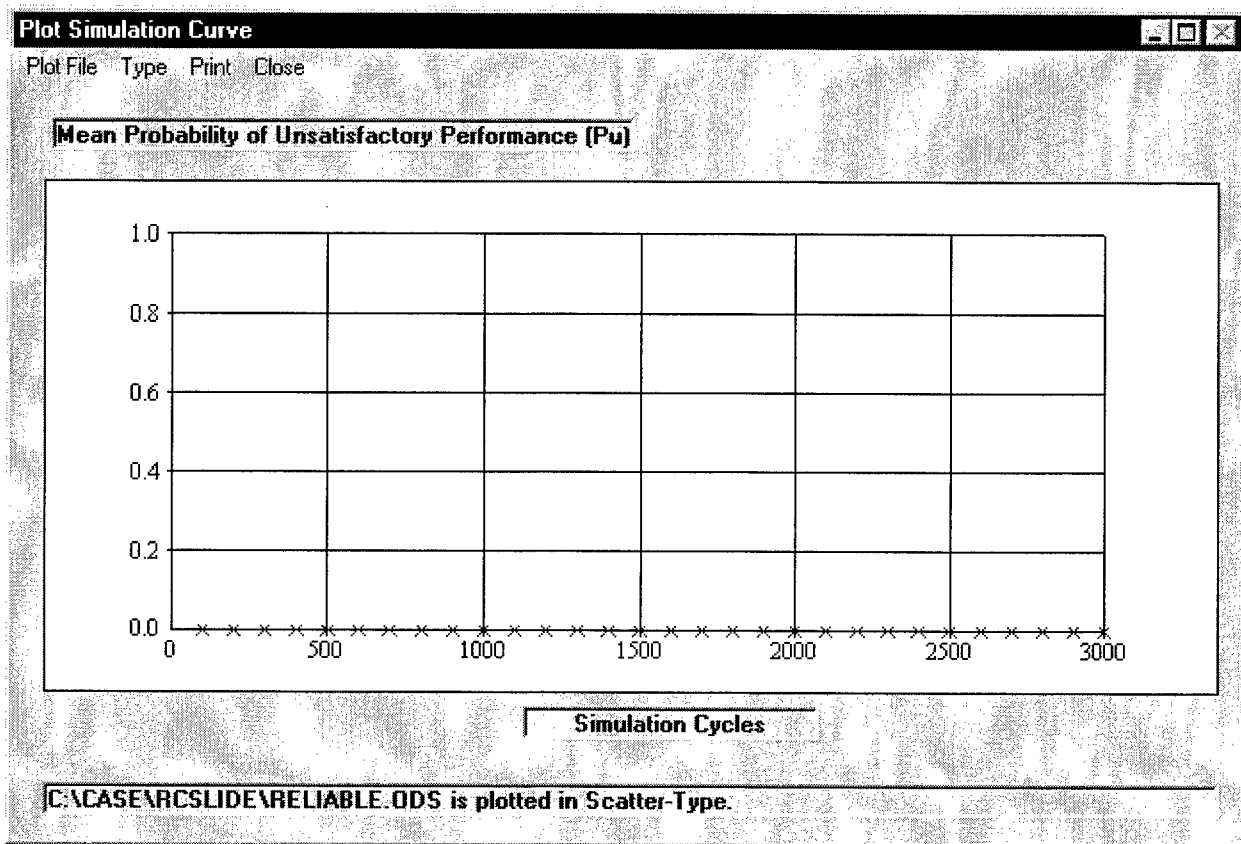

Figure C36. Plot of simulation result Problem 2B

Problem 2C

In this problem, RC SLIDE uses the importance sampling method of reliability analysis in conjunction with the CSLIDE data referred to in Problem 2A.

Input CSLIDE File: LD2M16D.dat

This file is the one used in Problem 2A previously in this appendix.

Input Reliability File: RELIABLE.dat

This file is used previously in this appendix.

Problem 2C output

There are two output files generated by executing the **Analysis** option **Run SIMU-Importance Sampling Simulation**, a CSLIDE analysis output file and the reliability assessment output file. These files can be saved as previously shown in Problem 1 of this appendix.

The reliability index and probability of unsatisfactory performance for the monolith under sliding analysis conditions using simulation with importance sampling for reliability assessment is presented in Figure C37, which is followed by a listing of the output file.

The screenshot shows a window titled "Run RC SLIDE" with a menu bar (File, Analysis, Print, Options, Help). The main area displays the following information:

CSLIDE INPUT DATA FILE: C:\CASE\RC SLIDE\LD2M16D.DAT
RELIABILITY INPUT DATA FILE: C:\CASE\RC SLIDE\RELIABLE.DAT
(Simulation) 'runsimu.dat' contains the following information: Importance sampling

Simulation cycles (even integer):	3000
Initial given simulation seed:	0
Simulation output increment:	100
Importance sampling target safety factor:	1.0
Importance sampling shift ratio:	0.1

Result:	Safety factor	13.999	<input type="button" value="Execute"/> <input type="button" value="Close"/>
	Reliability index	8.000	
	Unsatisfactory performance probability:	0.00000	

NOTE:
1. Input the 1st field and press ENTER or RETURN key to copy the 1st field to 2nd and 3rd field.
Running runcsli.bat is finished.

Figure C37. Probability of unsatisfactory performance—importance sampling

Output File Listing generated by running the Importance Sampling method of reliability analysis for Problem 2C: RELIABLE.ois

Title =

Total number of random variables = 7

***** The input data *****

-x=rv-	--name--	----mean----	---Sigma---	----cov-----	code	Type
X(1)	STRU 0 1	.150000D+00	.750000D-02	.500000D-01	S	NOR
X(2)	SOLT 1 3	.330000D+02	.330000D+01	.100000D+00	S	NOR
X(3)	SOLT 1 5	.755000D-01	.377500D-02	.500000D-01	S	NOR
X(4)	SORT 1 3	.330000D+02	.330000D+01	.100000D+00	S	NOR
X(5)	SORT 1 5	.755000D-01	.377500D-02	.500000D-01	S	NOR
X(6)	SOST 0 3	.563100D+02	.130000D+02	.230865D+00	S	NOR
X(7)	SOST 0 4	.110000D+02	.770000D+00	.700000D-01	S	NOR

Correlation for SOST 0 = -.690000D+00

The limit state $Z=R-L=L(SF-1)$ or $Z=SF-1$

The simulation cycle = 3000
 The initial given seed = 0
 The simulation output increment = 100
 The target safety factor = .100000D+01
 The safety factor shift ratio = .100000D+00

<<< The sensitivity result >>>

The safety factor (SF) = .139994E+02

-x=rv-	--Name--	--M=Mean--	SF1:M* .90	SF2:M*1.10	--SF1-SF-	--SF2-SF--	--Sense.--
X(1)	STRU 0 1	.1500D+00	.1328D+02	.1472D+02	-.7212D+00	.7212D+00	.9000D+00
X(2)	SOLT 1 3	.3300D+02	.1399D+02	.1400D+02	-.4829D-02	.5149D-02	.9000D+00
X(3)	SOLT 1 5	.7550D-01	.1433D+02	.1369D+02	.3283D+00	-.3123D+00	.1100D+01
X(4)	SORT 1 3	.3300D+02	.1399D+02	.1401D+02	-.5749D-02	.6270D-02	.9000D+00
X(5)	SORT 1 5	.7550D-01	.1362D+02	.1439D+02	-.3760D+00	.3953D+00	.9000D+00
X(6)	SOST 0 3	.5631D+02	.1303D+02	.1530D+02	-.9654D+00	.1301D+01	.9000D+00
X(7)	SOST 0 4	.1100D+02	.1313D+02	.1487D+02	-.8699D+00	.8699D+00	.9000D+00

<<< The shifted means >>>

NOTE correlated random variables were not shifted**

-x=rv-	--Name--	---M=Mean---	Shifted.Mean	---Ratio---
X(1)	STRU 0 1	.150000D+00	.277953D-01	.185302D+00
X(2)	SOLT 1 3	.330000D+02	.611497D+01	.185302D+00
X(3)	SOLT 1 5	.755000D-01	.346920D+00	.459497D+01
X(4)	SORT 1 3	.330000D+02	.611497D+01	.185302D+00
X(5)	SORT 1 5	.755000D-01	.139903D-01	.185302D+00
X(6)	SOST 0 3	.563100D+02	.563100D+02	.100000D+01
X(7)	SOST 0 4	.110000D+02	.110000D+02	.100000D+01

The safety factor = .863829D+00
 The iteration of shifting = 16

***** The result *****

The initial random seed = -1855377

*** The result of importance sampling simulation ***

```
=====
No.of.cycle- -ave.cum.Pf- -COV(avePf)- B.COv(avePf)
-----
      100 .000000E+00
      200 .000000E+00
      300 .000000E+00
      400 .000000E+00
      500 .000000E+00
      600 .000000E+00
      700 .000000E+00
      800 .000000E+00
      900 .000000E+00
     1000 .000000E+00
     1100 .000000E+00
     1200 .000000E+00
     1300 .000000E+00
     1400 .000000E+00
     1500 .000000E+00
     1600 .000000E+00
     1700 .000000E+00
     1800 .000000E+00
     1900 .000000E+00
     2000 .000000E+00
     2100 .000000E+00
     2200 .000000E+00
     2300 .000000E+00
     2400 .000000E+00
     2500 .000000E+00
     2600 .000000E+00
     2700 .000000E+00
     2800 .000000E+00
     2900 .000000E+00
     3000 .000000E+00
=====
```

```
The importance failure count =          14
The safety factor > 10 count =          18
The minimum safety factor    =-.727643D+01
The maximum safety factor    = .140975D+16
The reliability index (beta) = .800000E+01

The binomial statistics
The ave of   Pf      (AvePf) = .000000D+00
The var of avePf (varAvePf) = .000000D+00
The std of avePf (stdAvePf) = .000000D+00
The cov of avePf (covAvePf) =N/A
```

```
The simulation and sample mean statistics
The ave of   Pf      (avePf) = .000000D+00
The var of   Pf      (varPf)b = .000000D+00
The var of   Pf      (varPf) = .000000D+00
The std of   Pf      (stdPf) = .000000D+00
The cov of   Pf      (covPf) =N/A
The var of avePf (varAvePf)b = .000000D+00
The var of avePf (varAvePf) = .000000D+00
The std of avePf (stdAvePf) = .000000D+00
The cov of avePf (covAvePf) =N/A
```

b = biased, for variance computation using the sample size N

The Prog-start time=10:54:50: 21 Date=1999- 3-22
The simu-start time=10:54:52: 98 Date=1999- 3-22
The simu-end time=11: 0:34: 65 Date=1999- 3-22
The Prog-end time=11: 0:34: 65 Date=1999- 3-22

Plot of simulation curve. A plot of the probability of unsatisfactory performance at each output iteration cycle is given in Figure C38.

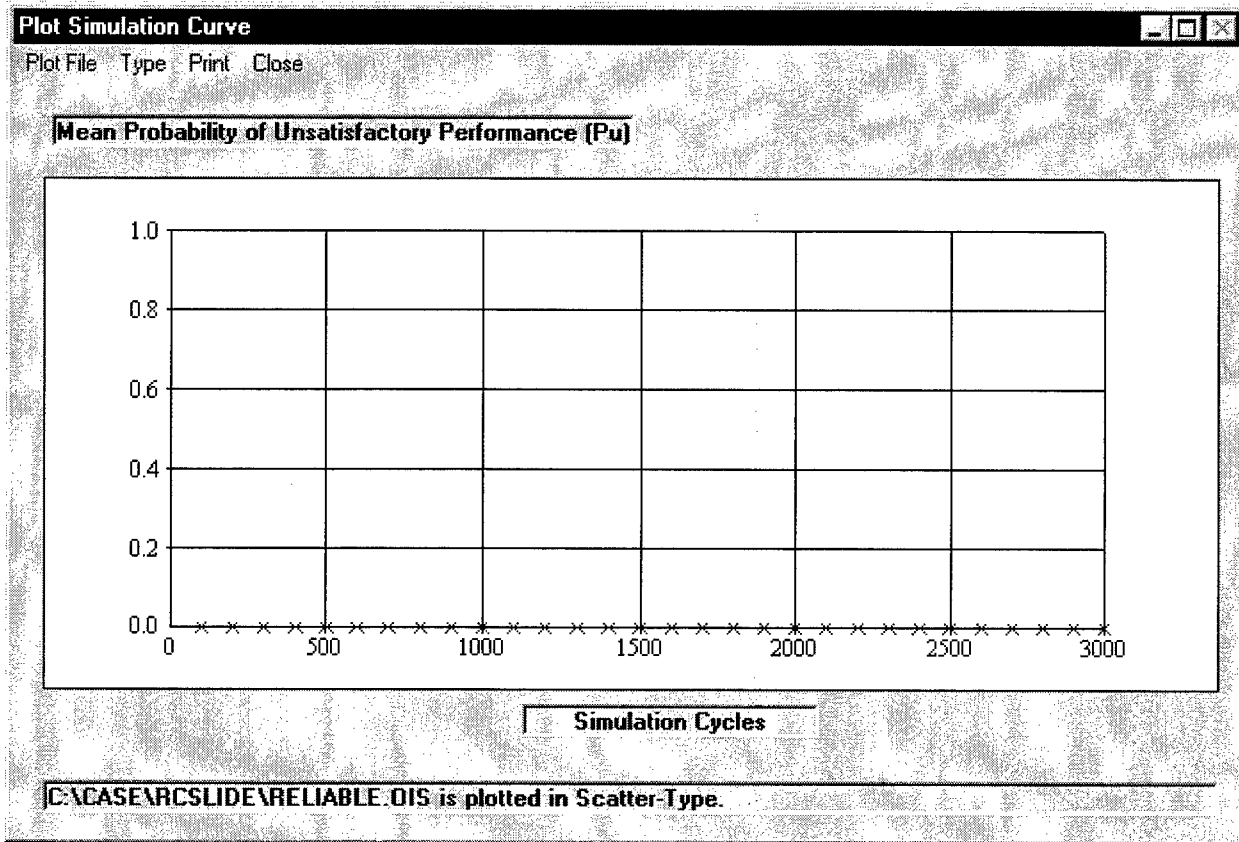

Figure C38. Plot of simulation result Problem 2C

Appendix D

CSLIDE/RCSLIDE Routines

The computer program, RCSLIDE, which implements the procedures discussed earlier in this report, is written in Microsoft Visual Basic (windows interface and graphic routines) and Fortran 90 (CSLIDE and reliability procedures). The program provides interactive operation using Microsoft Windows. All arithmetic operations are performed in single precision. A discussion of each routine in RCSLIDE is provided below along with a basic flowchart of the CSLIDE program.

Main CSLIDE FORTRAN Program

The main routine controls the type of output desired, either all iterations (CSLIDE only) or the final results. The solution process for CSLIDE is shown in the flowchart in Figure D1.

FORTRAN Subroutines

The program contains many subroutines, whose basic function is discussed in the following list:

- | | |
|----------|--|
| answer | - gets an answer and returns a 1 for yes and 2 for no |
| asm_main | - main routine for ASM - Advanced Second Moment Method |
| betcdf | - returns the beta distribution cdf |
| betinv | - returns the inverse cdf of beta distribution |
| betmom | - returns the beta distribution moments |
| betpar | - returns the beta distribution parameters |
| betpdf | - returns the beta distribution pdf |

binary_search	- finds x by a binary search
binary_search_vx	- finds vx by a binary search
ccreate	- reads in the coordinates of the points defining the structure and calculates the weight of the structure
control	- reads data from the file using a keyword format
crit_prt	- prints the critical input in the output
csli_main	- starts the CSLIDE analysis
cslide	- main CSLIDE program in pervious version
csliEq	- calculates a Factor of Safety by calling the CSLIDE subroutine
dalcr	- computes the critical failure angles of the right-side wedges for a multiple-plane failure analysis
dalpha	- sets the initial failure angles of the right-side wedges to $45 + \phi/2$
datetime	- determines the system date and time and coverts it to correct format
dcfr	- splits data lines apart and writes each item on a separate line
dcrit	- computes the critical failure angles of the right-side wedges for a single-plane failure analysis
directional_cosines	- calculates the directional cosine for all random variables
directional_cosines_prt	- print directional cosine for all random variables in the output
dnstrm	- reads in the coordinates and soil properties of the right-side soil layers
dscrip	- prints a condensed version of the user's guide at the terminal (not used by current RCSLIDE program)
dwedge	- calculates the weight and uplift force for the right-side wedges for a given failure angle
echo	- prints the input data to a file

edit	- allows the user to edit selected sections of the current data and rerun the problem (not used by current RCSLIDE program)
Eq_Normal	- calculates the moments of equivalent normal distribution
Eq_Normal_prt	- prints the moments of equivalent normal distribution in the output
extra	- calculates the weight of any soil below the base of the structure that is included in the structural wedge
expcdf	- returns the exponential distribution cdf
expinv	- returns the inverse cdf of an exponential distribution
expmom	- returns the exponential distribution moments
exppar	- returns the exponential distribution parameter
exppdf	- returns the exponential distribution pdf
failure_prob	- compute the probability of failure
fext	- reads in any external forces that act on the system
filget	- gets an existing file or opens a new file
findx	- calculates the coordinates of the points where the soil layers intersect the structure
fnldd	- calculates the total applied external forces, both horizontal and vertical, that act on a particular wedge
gamcdf	- returns the gamma (Erlang) distribution cdf
gamcf	- returns the incomplete gamma function by continued fraction
gaminv	- returns the inverse cdf of a gamma distribution
gamma	- returns the value of a gamma function
gammai	- returns the incomplete gamma function
gammom	- returns the gamma (Erlang) distribution moments
gampar	- returns the gamma (Erlang) distribution parameters

gampdf	- returns the gamma (Erlang) distribution pdf
gamser	- returns the incomplete gamma function by series expansion
get_beta	- calculates beta using regular falsi method
get_beta_range	- calculates the beta_range
get_bin_var	- calculates the binomial statistics: variance, standard deviation, and COV
get_dp	- gets the design point
get_dp_prt	- prints the design points in the output
get_epsb	- calculates epsb for beta convergence
get_increment	- calculates the increment - nout=ncycle/increment ==> increment=ncycle/nout
get_inverse	- determines the inverse (= rv. X) from a cdf
get_pdf	- computes the pdf from X, its mean, and its standard deviation
get_sum	- summation used in the ln (gamma) function
get_var	- computes the variance, standard deviation, and COV
get_vxmax	- obtains the maximum vx
get_xk_y1	- computes xk and y1 (xu=mean/y1)
get_xkmax_y1	- computes xkmax, xk=xkmax, and y1 (xu=mean/y1)
get_xmax	- determines the maximum x
header	- reads in a title for a problem
input_prt	- prints the input in the output
left	- finds the intersection point of a failure angle with a soil surface for the left-side wedges
limitState_prt	- prints the limit state
logcdf	- returns the value of a lognormal cdf
loginv	- returns the inverse cdf of a lognormal distribution

logmom	- returns the lognormal moments, mean X, and sigma X
logpar	- returns the lognormal parameters mean Y and sigma Y
logpdf	- returns the value of a lognormal pdf
new	- initializes variables for use when more than one problem is analyzed
norcdf	- returns the normal distribution cdf
norinv	- returns the inverse cdf a normal distribution
norpdf	- returns the normal distribution pdf
nortab	- returns power = the value of $\log_{10}(Q(z))$ by linear interpolation
partial	- calculates the partial derivative for random variables in ultstr
partial_prt	- prints partial derivative for random variables in the output
press	- calculates the sum of the net forces acting on the wedges
print	- prints the results of an analysis to a file
raycdf	- returns the Rayleigh distribution cdf
rayinv	- returns the inverse cdf of a Rayleigh distribution
raymom	- returns the Rayleigh distribution moments
raypar	- returns the Rayleigh distribution parameter
raypdf	- returns the Rayleigh distribution pdf
read_csl	- reads the CSLIDE data from a temporary file
right	- finds the intersection of a failure angle and a soil layer for the right-side wedges
savein	- saves the input data to a permanent file
sensitivity_prt	- prints the sensitivity test

set	- allows the user to specify the failure angle of any wedge
set_asm_logicals	- set ASM logicals
setblk	- blank fills a specific number of characters starting at a particular character
shifting_prt	- prints the shifting of selected control variables
simu_dr_main	- main subroutine for direct Monte Carlo simulation
simu_is_main	- main subroutine for importance sampling simulation
solve	- finds the intersection of two lines
sort	- sorts in order and stores each distinct x-coordinate of all the soil layers for a particular side and calculates the y-coordinate of each layer at each distinct x-coordinate
strip	- removes the line numbers from an input data file
swedge	- calculates the weight of the structural wedge and the uplift force acting on it
t1lcdf	- returns the Extreme Value Type I largest (Gumbel) distribution cdf
t1linv	- returns the inverse cdf of an Extreme Value Type I largest (Gumbel) distribution
t1lmom	- returns the Extreme Value Type I largest (Gumbel) distribution moments
t1lpar	- returns the Extreme Value Type I largest (Gumbel) distribution parameters
t1lpdf	- returns the Extreme Value Type I largest (Gumbel) distribution pdf
t1scdf	- returns the Extreme Value Type I smallest (Gumbel) distribution cdf
t1sinv	- returns the inverse cdf of an Extreme Value Type I smallest (Gumbel) distribution
t1smom	- returns the Extreme Value Type I smallest (Gumbel) distribution first and second moments

t1spar	- returns the Extreme Value Type I smallest (Gumbel) distribution parameters
t1spdf	- returns the Extreme Value Type I smallest (Gumbel) distribution pdf
t2lcdf	- returns the Type II largest (Frechet) distribution cdf
t2linv	- returns the inverse cdf of Type II largest (Frechet) distribution
t2lmom	- returns the Type II (largest) distribution first and second moments
t2lpar	- returns the shape parameter x_k and scale parameter x_u of Type II (largest) distribution
t2lpdf	- returns the Type II largest (Frechet) distribution pdf
t3lcdf	- returns the Extreme Value Type III largest (Weibull) distribution cdf
t3linv	- returns the inverse cdf of an Extreme Value Type III largest (Weibull) distribution
t3lmom	- returns the Extreme Value Type III largest (Weibull) distribution moments
t3lpar	- returns the shape parameter x_k and scale parameter x_u for a Type III Weibull (largest) distribution
t3lpdf	- returns the Extreme Value Type III largest (Weibull) distribution pdf
t3scdf	- returns the Extreme Value Type III smallest (Weibull) distribution cdf
t3sinv	- returns the inverse cdf of a Extreme Value Type III smallest (Weibull) distribution
t3smom	- returns the Extreme Value Type III smallest (Weibull) distribution moments
t3spar	- returns the Extreme Value Type III smallest (Weibull) distribution parameters
t3spdf	- returns the Extreme Value Type III smallest (Weibull) distribution pdf
ts3_get_xkmax_y1	- calculates x_{kmax} , $x_k=x_{kmax}$, and $y1$ (for x_u).

ts3_xk_y1	- computes xk & y1 (for xu)
type	- reads in the method of analysis, safety factor ratio, and the upper and lower bounds for the FS
unicdf	- returns the uniform distribution cdf
uniinv	- returns the inverse cdf of a uniform distribution
unimom	- returns the first and second moments of a uniform distribution
unipar	- returns parameters a & b of a uniform distribution
unipdf	- returns the uniform distribution pdf
updateDp	- updates the value of the design point in ASM
upper	- converts lower case characters to upper case
valcr	- calculates the critical failure angles of the left-side wedges for the multiple-plane failure analysis
valpha	- sets the initial failure angles of the left-side wedges to $(45 - \phi/2)$
vcrit	- calculates the critical failure angles for the left-side wedge for the single-plane failure analysis
vnder	- reads in the properties of the soil below the structure
vpstrm	- reads in the coordinates and soil properties of the left-side soil layers
vwedge	- calculates the weight and uplift force for the left-side wedges of a particular failure angle
watr	- reads in the elevation of the water on the left and right sides of the structure, the desired method to compute uplift pressures, an uplift force on the structural wedge, and water pressures on the wedges
weight	- calculate weight of a soil volume
write_cqli	- writes the updated data to a CSLIDE temporary input file

FORTRAN Functions

The program contains several functions, and the purpose of each is discussed in the following list:

- angl - calculates $\phi/2$
- beta - returns beta function
- betac - beta function by continuous fraction approach
- betai - incomplete beta function
- box - defined as:
$$\text{Box}(x) = x, \text{ if } x \geq 0$$
$$\text{Box}(x) = 0, \text{ if } x < 0$$
- del - calculates the elevation of a soil layer on the right side at a specified x-coordinate
- dr - converts degrees to radians
- gammln - returns $\ln(\text{gamma})$
- kompch - compares characters in 2 arrays
- limitstate - defines the limit state
- mysign - returns ± 1 depending on sign of variable
- pcomp - calculates the net force $P_{i-1} - P_i$ on a given wedge using the general wedge equation
- ran2 - random number generator
- rd - converts radians to degrees
- seep2 - calculates the water pressures at the vertices of each wedge using the line-of-creep method and calculates an uplift force on each wedge
- seep3 - calculates the uplift force on a certain wedge using water pressures entered by the user
- vel - calculates the elevation of a specified x-coordinate for a soil layer on the left side
- xinter - interpolates between two sets of coordinates

Visual Basic Subroutines

The purpose of each Visual Basic subroutine is given in the following list:

- check - determines if screen input is of a valid type
- cmmnrtns - controls most of the actions taken when various forms are loaded
- declare - returns a variable in a specific format
- help - displays the contents of a help file in a text box
- loadingcmmn - controls data entered on the loads screen
- new1 - starts RCLIDE program and sets up a form for data entry
- open - read reliability or CSLIDE data from an opened file
- plot - general plotting routines
- runcmmn - generates information for FORTRAN analysis execution including creating temporary input/output files
- save - routines associated with data saves
- themaincmmn - saves, deletes, opens, and prints a file; exits the program and loads appropriate soil form
- view - opens and displays a file

Visual Basic Forms

Routines used to display a particular form include the following:

- about - program information
- anchors - anchor form
- browse - used to select path for saving output
- choice - choose application to run
- earthqks - earthquake conditions
- factor - factor of safety
- justonce - initial choice of which application to load

loadings	- RCSLIDE loads form
loadingc	- CSLIDE loads form
plot	- structure plot and failure surface plot
plots	- simulation plot
runc	- run RCSLIDE screen
runcc	- run CSLIDE screen
saveas	- save as form for selecting input/output file names
seepage	- seepage pressure information for RCSLIDE
seepagec	- seepage pressure information for CSLIDE
soil	- soil properties for RCSLIDE
soilc	- soil properties for CSLIDE
soilxy	- soil coordinate information
struct	- structural information for RCSLIDE
structc	- structural information for CSLIDE
themain	- main RCSLIDE information screen
view	- view form
water	- RCSLIDE water description
waterc	- CSLIDE water description
wedgspec	- wedge specifications
ync-msg	- yes/no/continue form

Flowchart

A basic flowchart of the program CSLIDE is shown in Figure D1.

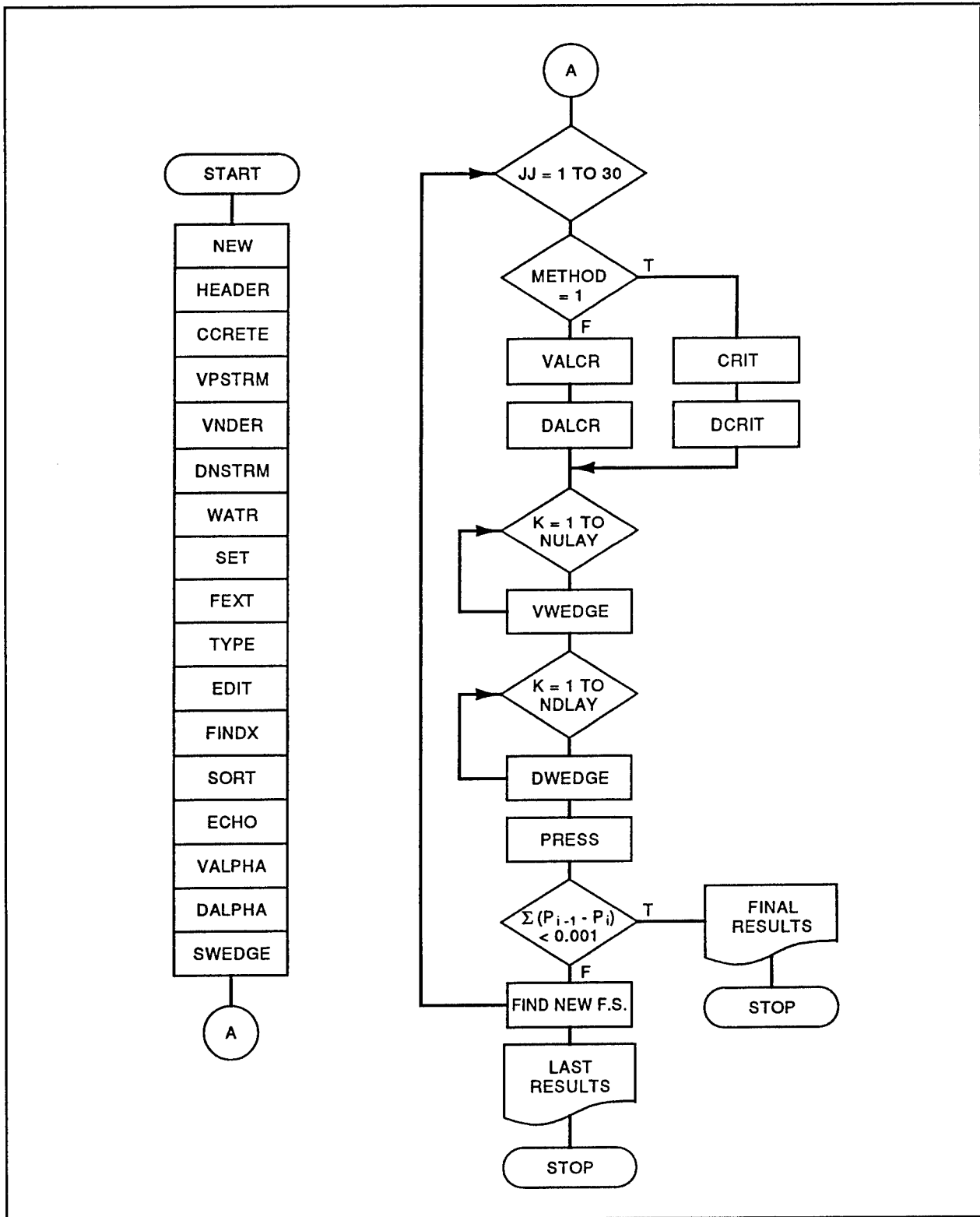

Figure D1. Flowchart of CSLIDE

Appendix E

Notation

ASM	Advanced second moment
c	Cohesion
cdf	cumulative density function
cov	coefficient of variation
F	Forces
FS	Factor of safety against sliding
h	Total head measured from an arbitrary datum
h_L	Head loss between two arbitrary points
h_{L_P}	Head loss incurred going to point P
H	Total head loss of system
H_L	Any horizontal force applied on the left side of a wedge that is above the top or below the bottom of an adjacent wedge
H_R	Any horizontal force applied on the right side of a wedge that is above the top or below the bottom of an adjacent wedge
$i, i-1, i+1$	Body or surface forces, dimensions or properties associated with the i^{th} wedge
L	Length of the base of a wedge along the failure surface
n	Axes normal to failure plane
N	Resultant normal force acting on the base of a wedge
P	Resultant earth force and water force acting on the vertical boundaries of a typical wedge
pdf	probability density function
P_P	Water pressure at an arbitrary point P
P_w	Pressure at an arbitrary point
t	Axes tangent to failure plane
T	Shearing force acting along the base of a wedge

T_F	Maximum shearing force along the base of a wedge that is available to resist sliding
U	Uplift force because of water forces acting on the base of a wedge
V	Any vertical force applied to a wedge, from above the top of the wedge
W	Total weight of concrete, water, and soil contained in a wedge
z	Elevation head of an arbitrary point
z_P	Elevation head of point P
α	Angle between the inclined plane of the base of a wedge and the horizontal
β	Reliability index
γ	Weight per unit volume
δ	Angle of wall friction between concrete and soil
σ	Normal stress
τ	Applied shear stress
τ_F	Maximum shear strength at failure
ϕ	The angle of shearing resistance or angle of internal friction

**REPORTS PUBLISHED UNDER
THE COMPUTER-AIDED STRUCTURAL
ENGINEERING (CASE) PROJECT**

	Title	Date
Technical Report K-78-1	List of Computer Programs for Computer-Aided Structural Engineering	Feb 1978
Instruction Report O-79-2	User's Guide: Computer Program with Interactive Graphics for Analysis of Plane Frame Structures (CFRAME)	Mar 1979
Technical Report K-80-1	Survey of Bridge-Oriented Design Software	Jan 1980
Technical Report K-80-2	Evaluation of Computer Programs for the Design/Analysis of Highway and Railway Bridges	Jan 1980
Instruction Report K-80-1	User's Guide: Computer Program for Design/Review of Curvilinear Conduits/Culverts (CURCON)	Feb 1980
Instruction Report K-80-3	A Three-Dimensional Finite Element Data Edit Program	Mar 1980
Instruction Report K-80-4	A Three-Dimensional Stability Analysis/Design Program (3DSAD) Report 1: General Geometry Module Report 3: General Analysis Module (CGAM) Report 4: Special-Purpose Modules for Dams (CDAMS)	Jun 1980 Jun 1982 Aug 1983
Instruction Report K-80-6	Basic User's Guide: Computer Program for Design and Analysis of Inverted-T Retaining Walls and Floodwalls (TWDA)	Dec 1980
Instruction Report K-80-7	User's Reference Manual: Computer Program for Design and Analysis of Inverted-T Retaining Walls and Floodwalls (TWDA)	Dec 1980
Technical Report K-80-4	Documentation of Finite Element Analyses Report 1: Longview Outlet Works Conduit Report 2: Anchored Wall Monolith, Bay Springs Lock	Dec 1980 Dec 1980
Technical Report K-80-5	Basic Pile Group Behavior	Dec 1980
Instruction Report K-81-2	User's Guide: Computer Program for Design and Analysis of Sheet Pile Walls by Classical Methods (CSHTWAL) Report 1: Computational Processes Report 2: Interactive Graphics Options	Feb 1981 Mar 1981
Instruction Report K-81-3	Validation Report: Computer Program for Design and Analysis of Inverted-T Retaining Walls and Floodwalls (TWDA)	Feb 1981
Instruction Report K-81-4	User's Guide: Computer Program for Design and Analysis of Cast-in-Place Tunnel Linings (NEWTUN)	Mar 1981
Instruction Report K-81-6	User's Guide: Computer Program for Optimum Nonlinear Dynamic Design of Reinforced Concrete Slabs Under Blast Loading (CBARCS)	Mar 1981
Instruction Report K-81-7	User's Guide: Computer Program for Design or Investigation of Orthogonal Culverts (CORTCUL)	Mar 1981
Instruction Report K-81-9	User's Guide: Computer Program for Three-Dimensional Analysis of Building Systems (CTABS80)	Aug 1981
Technical Report K-81-2	Theoretical Basis for CTABS80: A Computer Program for Three-Dimensional Analysis of Building Systems	Sep 1981
Instruction Report K-82-6	User's Guide: Computer Program for Analysis of Beam-Column Structures with Nonlinear Supports (CBEAMC)	Jun 1982

(Continued)

REPORTS PUBLISHED UNDER THE COMPUTER-AIDED STRUCTURAL ENGINEERING (CASE) PROJECT

(Continued)

	Title	Date
Instruction Report K-82-7	User's Guide: Computer Program for Bearing Capacity Analysis of Shallow Foundations (CBEAR)	Jun 1982
Instruction Report K-83-1	User's Guide: Computer Program with Interactive Graphics for Analysis of Plane Frame Structures (CFRAME)	Jan 1983
Instruction Report K-83-2	User's Guide: Computer Program for Generation of Engineering Geometry (SKETCH)	Jun 1983
Instruction Report K-83-5	User's Guide: Computer Program to Calculate Shear, Moment, and Thrust (CSMT) from Stress Results of a Two-Dimensional Finite Element Analysis	Jul 1983
Technical Report K-83-1	Basic Pile Group Behavior	Sep 1983
Technical Report K-83-3	Reference Manual: Computer Graphics Program for Generation of Engineering Geometry (SKETCH)	Sep 1983
Technical Report K-83-4	Case Study of Six Major General-Purpose Finite Element Programs	Oct 1983
Instruction Report K-84-2	User's Guide: Computer Program for Optimum Dynamic Design of Nonlinear Metal Plates Under Blast Loading (CSDOOR)	Jan 1984
Instruction Report K-84-7	User's Guide: Computer Program for Determining Induced Stresses and Consolidation Settlements (CSETT)	Aug 1984
Instruction Report K-84-8	Seepage Analysis of Confined Flow Problems by the Method of Fragments (CFRAG)	Sep 1984
Instruction Report K-84-11	User's Guide for Computer Program CGFAG, Concrete General Flexure Analysis with Graphics	Sep 1984
Technical Report K-84-3	Computer-Aided Drafting and Design for Corps Structural Engineers	Oct 1984
Technical Report ATC-86-5	Decision Logic Table Formulation of ACI 318-77, Building Code Requirements for Reinforced Concrete for Automated Constraint Processing, Volumes I and II	Jun 1986
Technical Report ITL-87-2	A Case Committee Study of Finite Element Analysis of Concrete Flat Slabs	Jan 1987
Instruction Report ITL-87-1	User's Guide: Computer Program for Two-Dimensional Analysis of U-Frame Structures (CUFRAM)	Apr 1987
Instruction Report ITL-87-2	User's Guide: For Concrete Strength Investigation and Design (CASTR) in Accordance with ACI 318-83	May 1987
Technical Report ITL-87-6	Finite-Element Method Package for Solving Steady-State Seepage Problems	May 1987
Instruction Report ITL-87-3	User's Guide: A Three-Dimensional Stability Analysis/Design Program (3DSAD) Module	Jun 1987
	Report 1: Revision 1: General Geometry	Jun 1987
	Report 2: General Loads Module	Sep 1989
	Report 6: Free-Body Module	Sep 1989

(Continued)

REPORTS PUBLISHED UNDER THE COMPUTER-AIDED STRUCTURAL ENGINEERING (CASE) PROJECT

(Continued)

	Title	Date
Instruction Report ITL-87-4	User's Guide: 2-D Frame Analysis Link Program (LINK2D)	Jun 1987
Technical Report ITL-87-4	Finite Element Studies of a Horizontally Framed Miter Gate Report 1: Initial and Refined Finite Element Models (Phases A, B, and C), Volumes I and II Report 2: Simplified Frame Model (Phase D) Report 3: Alternate Configuration Miter Gate Finite Element Studies--Open Section Report 4: Alternate Configuration Miter Gate Finite Element Studies--Closed Sections Report 5: Alternate Configuration Miter Gate Finite Element Studies--Additional Closed Sections Report 6: Elastic Buckling of Girders in Horizontally Framed Miter Gates Report 7: Application and Summary	Aug 1987
Instruction Report GL-87-1	User's Guide: UTEXAS2 Slope-Stability Package; Volume I, User's Manual	Aug 1987
Instruction Report ITL-87-5	Sliding Stability of Concrete Structures (CSLIDE)	Oct 1987
Instruction Report ITL-87-6	Criteria Specifications for and Validation of a Computer Program for the Design or Investigation of Horizontally Framed Miter Gates (CMITER)	Dec 1987
Technical Report ITL-87-8	Procedure for Static Analysis of Gravity Dams Using the Finite Element Method - Phase 1a	Jan 1988
Instruction Report ITL-88-1	User's Guide: Computer Program for Analysis of Planar Grid Structures (CGRID)	Feb 1988
Technical Report ITL-88-1	Development of Design Formulas for Ribbed Mat Foundations on Expansive Soils	Apr 1988
Technical Report ITL-88-2	User's Guide: Pile Group Graphics Display (CPGG) Post-processor to CPGA Program	Apr 1988
Instruction Report ITL-88-2	User's Guide for Design and Investigation of Horizontally Framed Miter Gates (CMITER)	Jun 1988
Instruction Report ITL-88-4	User's Guide for Revised Computer Program to Calculate Shear, Moment, and Thrust (CSMT)	Sep 1988
Instruction Report GL-87-1	User's Guide: UTEXAS2 Slope-Stability Package; Volume II, Theory	Feb 1989
Technical Report ITL-89-3	User's Guide: Pile Group Analysis (CPGA) Computer Group	Jul 1989
Technical Report ITL-89-4	CBASIN--Structural Design of Saint Anthony Falls Stilling Basins According to Corps of Engineers Criteria for Hydraulic Structures; Computer Program X0098	Aug 1989

(Continued)

REPORTS PUBLISHED UNDER THE COMPUTER-AIDED STRUCTURAL ENGINEERING (CASE) PROJECT

(Continued)

	Title	Date
Technical Report ITL-89-5	CCHAN—Structural Design of Rectangular Channels According to Corps of Engineers Criteria for Hydraulic Structures; Computer Program X0097	Aug 1989
Technical Report ITL-89-6	The Response-Spectrum Dynamic Analysis of Gravity Dams Using the Finite Element Method; Phase II	Aug 1989
Contract Report ITL-89-1	State of the Art on Expert Systems Applications in Design, Construction, and Maintenance of Structures	Sep 1989
Instruction Report ITL-90-1	User's Guide: Computer Program for Design and Analysis of Sheet Pile Walls by Classical Methods (CWALSHT)	Feb 1990
Technical Report ITL-90-3	Investigation and Design of U-Frame Structures Using Program CUFRBC Volume A: Program Criteria and Documentation Volume B: User's Guide for Basins Volume C: User's Guide for Channels	May 1990
Instruction Report ITL-90-6	User's Guide: Computer Program for Two-Dimensional Analysis of U-Frame or W-Frame Structures (CWFRAM)	Sep 1990
Instruction Report ITL-90-2	User's Guide: Pile Group—Concrete Pile Analysis Program (CPGC) Preprocessor to CPGA Program	Jun 1990
Technical Report ITL-91-3	Application of Finite Element, Grid Generation, and Scientific Visualization Techniques to 2-D and 3-D Seepage and Groundwater Modeling	Sep 1990
Instruction Report ITL-91-1	User's Guide: Computer Program for Design and Analysis of Sheet-Pile Walls by Classical Methods (CWALSHT) Including Rowe's Moment Reduction	Oct 1991
Instruction Report ITL-87-2 (Revised)	User's Guide for Concrete Strength Investigation and Design (CASTR) in Accordance with ACI 318-89	Mar 1992
Technical Report ITL-92-2	Finite Element Modeling of Welded Thick Plates for Bonneville Navigation Lock	May 1992
Technical Report ITL-92-4	Introduction to the Computation of Response Spectrum for Earthquake Loading	Jun 1992
Instruction Report ITL-92-3	Concept Design Example, Computer-Aided Structural Modeling (CASM) Report 1: Scheme A Report 2: Scheme B Report 3: Scheme C	Jun 1992 Jun 1992 Jun 1992
Instruction Report ITL-92-4	User's Guide: Computer-Aided Structural Modeling (CASM) -Version 3.00	Apr 1992
Instruction Report ITL-92-5	Tutorial Guide: Computer-Aided Structural Modeling (CASM) -Version 3.00	Apr 1992

(Continued)

REPORTS PUBLISHED UNDER THE COMPUTER-AIDED STRUCTURAL ENGINEERING (CASE) PROJECT

(Continued)

	Title	Date
Contract Report ITL-92-1	Optimization of Steel Pile Foundations Using Optimality Criteria	Jun 1992
Technical Report ITL-92-7	Refined Stress Analysis of Melvin Price Locks and Dam	Sep 1992
Contract Report ITL-92-2	Knowledge-Based Expert System for Selection and Design of Retaining Structures	Sep 1992
Contract Report ITL-92-3	Evaluation of Thermal and Incremental Construction Effects for Monoliths AL-3 and AL-5 of the Melvin Price Locks and Dam	Sep 1992
Instruction Report GL-87-1	User's Guide: UTEXAS3 Slope-Stability Package; Volume IV, User's Manual	Nov 1992
Technical Report ITL-92-11	The Seismic Design of Waterfront Retaining Structures	Nov 1992
Technical Report ITL-92-12	Computer-Aided, Field-Verified Structural Evaluation	
	Report 1: Development of Computer Modeling Techniques for Miter Lock Gates	Nov 1992
	Report 2: Field Test and Analysis Correlation at John Hollis Bankhead Lock and Dam	Dec 1992
	Report 3: Field Test and Analysis Correlation of a Vertically Framed Miter Gate at Emsworth Lock and Dam	Dec 1993
Instruction Report GL-87-1	User's Guide: UTEXAS3 Slope-Stability Package; Volume III, Example Problems	Dec 1992
Technical Report ITL-93-1	Theoretical Manual for Analysis of Arch Dams	Jul 1993
Technical Report ITL-93-2	Steel Structures for Civil Works, General Considerations for Design and Rehabilitation	Aug 1993
Technical Report ITL-93-3	Soil-Structure Interaction Study of Red River Lock and Dam No. 1 Subjected to Sediment Loading	Sep 1993
Instruction Report ITL-93-3	User's Manual—ADAP, Graphics-Based Dam Analysis Program	Aug 1993
Instruction Report ITL-93-4	Load and Resistance Factor Design for Steel Miter Gates	Oct 1993
Technical Report ITL-94-2	User's Guide for the Incremental Construction, Soil-Structure Interaction Program SOILSTRUCT with Far-Field Boundary Elements	Mar 1994
Instruction Report ITL-94-1	Tutorial Guide: Computer-Aided Structural Modeling (CASM); Version 5.00	Apr 1994
Instruction Report ITL-94-2	User's Guide: Computer-Aided Structural Modeling (CASM); Version 5.00	Apr 1994
Technical Report ITL-94-4	Dynamics of Intake Towers and Other MDOF Structures Under Earthquake Loads: A Computer-Aided Approach	Jul 1994
Technical Report ITL-94-5	Procedure for Static Analysis of Gravity Dams Including Foundation Effects Using the Finite Element Method – Phase 1B	Jul 1994

(Continued)

REPORTS PUBLISHED UNDER THE COMPUTER-AIDED STRUCTURAL ENGINEERING (CASE) PROJECT

(Continued)

	Title	Date
Instruction Report ITL-94-5	User's Guide: Computer Program for Winkler Soil-Structure Interaction Analysis of Sheet-Pile Walls (CWALSSI)	Nov 1994
Instruction Report ITL-94-6	User's Guide: Computer Program for Analysis of Beam-Column Structures with Nonlinear Supports (CBEAMC)	Nov 1994
Instruction Report ITL-94-7	User's Guide to CTWALL – A Microcomputer Program for the Analysis of Retaining and Flood Walls	Dec 1994
Contract Report ITL-95-1	Comparison of Barge Impact Experimental and Finite Element Results for the Lower Miter Gate of Lock and Dam 26	Jun 1995
Technical Report ITL-95-5	Soil-Structure Interaction Parameters for Structured/Cemented Silts	Aug 1995
Instruction Report ITL-95-1	User's Guide: Computer Program for the Design and Investigation of Horizontally Framed Miter Gates Using the Load and Resistance Factor Criteria (CMITER-LRFD)	Aug 1995
Technical Report ITL-95-8	Constitutive Modeling of Concrete for Massive Concrete Structures, A Simplified Overview	Sep 1995
Instruction Report ITL-96-1	User's Guide: Computer Program for Two-Dimensional Dynamic Analysis of U-Frame or W-Frame Structures (CDWFRM)	Jun 1996
Instruction Report ITL-96-2	Computer-Aided Structural Modeling (CASM), Version 6.00 Report 1: Tutorial Guide Report 2: User's Guide Report 3: Scheme A Report 4: Scheme B Report 5: Scheme C	Jun 1996
Technical Report ITL-96-8	Hyperbolic Stress-Strain Parameters for Structured/Cemented Silts	Aug 1996
Instruction Report ITL-96-3	User's Guide: Computer Program for the Design and Investigation of Horizontally Framed Miter Gates Using the Load and Resistance Factor Criteria (CMITERW-LRFD) Windows Version	Sep 1996
Instruction Report ITL-97-1	User's Guide: Computer Aided Inspection Forms for Hydraulic Steel Structures (CAIF-HSS), Windows Version	Sep 1997
Instruction Report ITL-97-2	User's Guide: Arch Dam Stress Analysis System (ADSAS)	Aug 1997
Instruction Report ITL-98-1	User's Guide for the Three-Dimensional Stability Analysis/Design (3DSAD) Program	Sep 1998
Technical Report ITL-98-4	Investigation of At-Rest Soil Pressures due to Irregular Sloping Soil Surfaces and CSOILP User's Guide	Sep 1998
Technical Report ITL-98-5	The Shear Ring Method and the Program Ring Wall	Sep 1998
Technical Report ITL-99-5	Rivet Replacement Analysis	Dec 1999

(Continued)

**REPORTS PUBLISHED UNDER
THE COMPUTER-AIDED STRUCTURAL
ENGINEERING (CASE) PROJECT**

(Concluded)

	Title	Date
ERDC/ITL TR-00-1	Evaluation and Comparison of Stability Analysis and Uplift Criteria for Concrete Gravity Dams by Three Federal Agencies	Jan 2000
ERDC/ITL TR-00-2	Reliability and Stability Assessment of Concrete Gravity Structures (RCSLIDE): User's Guide	Jul 2000

REPORT DOCUMENTATION PAGE

Form Approved
OMB No. 0704-0188

Public reporting burden for this collection of information is estimated to average 1 hour per response, including the time for reviewing instructions, searching existing data sources, gathering and maintaining the data needed, and completing and reviewing this collection of information. Send comments regarding this burden estimate or any other aspect of this collection of information, including suggestions for reducing this burden to Department of Defense, Washington Headquarters Services, Directorate for Information Operations and Reports (0704-0188), 1215 Jefferson Davis Highway, Suite 1204, Arlington, VA 22202-4302. Respondents should be aware that notwithstanding any other provision of law, no person shall be subject to any penalty for failing to comply with a collection of information if it does not display a currently valid OMB control number. **PLEASE DO NOT RETURN YOUR FORM TO THE ABOVE ADDRESS.**

1. REPORT DATE (DD-MM-YYYY) July 2000		2. REPORT TYPE Final report		3. DATES COVERED (From - To)	
4. TITLE AND SUBTITLE Reliability and Stability Assessment of Concrete Structures (RCSLIDE): User's Guide				5a. CONTRACT NUMBER	
				5b. GRANT NUMBER	
				5c. PROGRAM ELEMENT NUMBER	
6. AUTHOR(S) Mary Ann Leggett , Michael E. Pace, Fredrick Lyles, Kevin Abraham				5d. PROJECT NUMBER	
				5e. TASK NUMBER	
				5f. WORK UNIT NUMBER	
7. PERFORMING ORGANIZATION NAME(S) AND ADDRESS(ES) U.S. Army Engineer Research and Development Center Information Technology Laboratory 3909 Halls Ferry Road Vicksburg, MS 39180-6199				8. PERFORMING ORGANIZATION REPORT NUMBER ERDC/ITL TR-00-2	
9. SPONSORING / MONITORING AGENCY NAME(S) AND ADDRESS(ES) U.S. Army Corps of Engineers Washington, DC 20314-1000				10. SPONSOR/MONITOR'S ACRONYM(S)	
				11. SPONSOR/MONITOR'S REPORT NUMBER(S)	
12. DISTRIBUTION / AVAILABILITY STATEMENT Approved for public release; distribution is unlimited.					
13. SUPPLEMENTARY NOTES					
14. ABSTRACT This report is a documentation of RCSLIDE, the reliability version of CSLIDE, a computer program for assessing the sliding stability of concrete gravity structures using the limit equilibrium method described in EC 1110-2-291, "Stability Analysis of Concrete Structures." CSLIDE can compute the factor of safety against sliding considering the effects of numerous and varied conditions. The report is organized to present an overview of the sliding analysis and the capabilities of the program including reliability assessment, to discuss the development of the equations used in the sliding analysis and the analysis procedures and their implementation into the program, to discuss program input and output, and to present a user's guide. A theoretical discussion of the reliability analysis procedures and their implementation is provided in a companion manual. Example problems which demonstrate the capabilities of both CSLIDE and the reliability assessment are included in appendices. Another appendix provides a list of CSLIDE/RCSLIDE routines.					
15. SUBJECT TERMS					
Analysis		Gravity		Sliding	
Concrete		Reliability		Stability	
		Safety factor		Structures	
16. SECURITY CLASSIFICATION OF:			17. LIMITATION OF ABSTRACT	18. NUMBER OF PAGES	19a. NAME OF RESPONSIBLE PERSON
a. REPORT UNCLASSIFIED	b. ABSTRACT UNCLASSIFIED	c. THIS PAGE UNCLASSIFIED			348