

REPORT DOCUMENTATION PAGE

AFRL-SR-BL-TR-00-

ing the
cluding
2202-
currently

Public reporting burden for this collection of information is estimated to average 1 hour per response, including the time for reviewing data needed, and completing and reviewing this collection of information. Send comments regarding this burden estimate or any of this burden to Department of Defense, Washington Headquarters Services, Directorate for Information Operations and Reports (043401), 4801 Marking St., Washington, DC 20340-1301. Respondents should be aware that notwithstanding any other provision of law, no person shall be subject to any penalty for failing to provide information unless it is specifically required by statute. PLEASE DO NOT RETURN YOUR FORM TO THE ABOVE ADDRESS.

0450

1. REPORT DATE (DD-MM-YYYY) 26-08-2000		2. REPORT TYPE Final Report		3. DATES COVERED (FROM - TO) June 1, 1997-May 31, 2000	
4. TITLE AND SUBTITLE Interaction of EM Waves with Atmospheric Pressure Plasmas				5a. CONTRACT NUMBER	
				5b. GRANT NUMBER F49620-97-1-0472	
				5c. PROGRAM ELEMENT NUMBER	
6. AUTHOR(S) Dr. Mounir Laroussi				5d. PROJECT NUMBER	
				5e. TASK NUMBER 3484/TS	
				5f. WORK UNIT NUMBER	
7. PERFORMING ORGANIZATION NAME(S) AND ADDRESS(ES) Old Dominion University ODURF, P.O. Box 6369 800 West 46 th Street Norfolk, VA 23508				8. PERFORMING ORGANIZATION REPORT NUMBER	
9. SPONSORING / MONITORING AGENCY NAME(S) AND ADDRESS(ES) Air Force Office of Scientific Research 801 N. Randolph St., Rm. 732 Arlington, VA, 22203-1977				10. SPONSOR/MONITOR'S ACRONYM(S) AFOSR	
				11. SPONSOR/MONITOR'S REPORT NUMBER(S)	
12. DISTRIBUTION / AVAILABILITY STATEMENT Unlimited					
20000922 076					
13. SUPPLEMENTARY NOTES					
14. ABSTRACT This document is the final report on the research activities carried out under AFOSR AASERT Grant F49620-97-1-0472. It describes the various research tasks and events which took place in the duration of this grant. The focus of the main activities is the generation of large volume, non-thermal, atmospheric pressure plasmas, their diagnostics, and their interactions with EM waves and with the cells of microorganisms. Abstracts of conference presentations and copies of archival manuscripts authored by the P.I. and the students are included.					
15. SUBJECT TERMS Glow discharge, Atmospheric pressure, microorganisms, microwaves, non-thermal					
16. SECURITY CLASSIFICATION OF:			17. LIMITATION OF ABSTRACT Unlimited	18. NUMBER OF PAGES	19a. NAME OF RESPONSIBLE PERSON Dr. Robert J. Barker
a. REPORT Unclassified	b. ABSTRACT Unclassified	c. THIS PAGE Unclassified			19b. TELEPHONE NUMBER (include area code) (703) 696-8574

AUGMENTATION AWARDS FOR SCIENCE & ENGINEERING RESEARCH TRAINING (AASERT)
REPORTING FORM

The Department of Defense (DoD) requires certain information to evaluate the effectiveness of the AASERT Program. By accepting this Grant which bestows the AASERT funds, the Grantee agrees to provide 1) a brief (not to exceed one page) narrative technical report of the research training activities of the AASERT-funded student(s) and 2) the information should be provided to the Government's technical point of contract by each annual anniversary of the AASERT award date.

1. Grantee identification data: (R&T and Grant numbers found on Page 1 of Grant)

- a. OLD DOMINION UNIVERSITY
University Name
- b. F49620-97-1-0472 c. FQ8671-9701164 3484/TS
Grant Number R&T Number
- d. MOUNIR LAROUSSI e. From: 6-1-97 To: 5-31-00
P.I. Name AASERT Reporting Period

NOTE: Grant to which AASERT award is attached is referred to hereafter as "Parent Agreement".

2. Total funding of the Parent Agreement and the number of full-time equivalent graduate students (FTEGS) supported by the Parent Agreement during the 12-month period prior to the AASERT award date.

- a. Funding: \$ 135,594
- b. Number FTEGS: 0

3. Total funding of the Parent Agreement and the number of FTEGS supported by the Parent Agreement during the current 12-month period.

- a. Funding: \$ 135,594
- b. Number FTEGS: 0

4. Total AASERT funding and the number of FTEGS and undergraduate students (UGS) supported by AASERT funds during the current 12-month reporting period.

- a. Funding: \$ 82,002
- b. Number FTEGS: 1
- c. Number UGS: 0

VERIFICATION STATEMENT: I hereby verify that all students supported by the AASERT award are U.S. Citizens.

[Signature]
Principal Investigator

Date

8/27/00

Final Report

**AFOSR AASERT Grant F49620-97-1-0472
&
Sub-Grant from The University of Tennessee**

Prepared by

Dr. Mounir Laroussi, P.I. for ODU
Applied Research Center
12050 Jefferson Ave.
Newport News, VA, 23606

Submitted to

Dr. Robert J. Barker, Program Manager
Directorate of Physics and Electronics
Air Force Office of Scientific Research
801 N. Randolph St., Rm 732
Arlington, VA 22203-1977

and

Prof. Igor Alexeff, P.I. for UTK
The University of Tennessee
414 Ferris Hall
Knoxville, TN 37996-2100

Period Covered: June 1, 1997 to May 31, 2000

Business Contact:

Mr. Jerry Jones
ODURF, P.O. Box 6369
800 West 46th Street
Norfolk, VA 23508

Table of Contents

Section	Page
Abstract.....	1
Activities covering June 1, 1997 to November 30, 1998.....	2
Activities covering December 1, 1998 to May 31, 2000.....	3
Interactions.....	3
Technical Description.....	4
References.....	7
Personnel.....	9
Appendix.....	10

Abstract

Non-thermal discharges at atmospheric pressure and their applications are receiving increased attention [1]-[7]. This is due to emerging novel uses of these discharges in various industrial and military applications. Applications of special interest to the US Airforce are the use of non-thermal plasmas as ramparts against directed high power electromagnetic weapons, and as countermeasure to biological and chemical warfare. In this context, the P.I. has been carrying out theoretical and experimental work to advance the scientific and engineering knowledge in this field. Under this grant new means and methods to generate non-equilibrium, large volume plasmas at atmospheric have been investigated along with their potential applications as to suit the interest of AFOSR. The work carried out during the 3 years duration of this grant has involved two graduate students and one undergraduate student. Interdisciplinary collaborations have been established to the benefits of the students. The results of our research have been disseminated via conference presentations and archival publications.

Activities Covering June 1, 1997 to November 30, 1998

During the duration of this grant the P.I. has changed employment from the University of Tennessee (UTK) to Old Dominion University (ODU). For this reason the description of the various activities carried out under this grant are divided in two intervals. While still at the University of Tennessee, the activities of the students supported by this grant were the theoretical study of the interaction of microwaves with atmospheric pressure plasmas, the design and construction of a Glow Discharge at Atmospheric Pressure apparatus, and its use for biological decontamination experiments. The results of this work have been presented in scientific conferences and published in archival journals. Of special mention are two archival manuscripts co-authored by the students: "Attenuation of Electromagnetic Waves by a Plasma Layer at Atmospheric Pressure", *Int. J. Infrared & Millimeter Waves*, Vol. 19, No. 3, pp. 453-464, 1998, and "Images of Biological Samples Undergoing Sterilization by a Glow Discharge at Atmospheric Pressure", *IEEE Transactions on Plasma Science*, Vol.27, No.1, pp. 34-35, 1999. Copies of these manuscripts are included in the Appendix.

During the summer of 1997, one of students supported by this grant attended the MAGIC training sessions held at the University of Michigan. During this course the student was introduced to Particle-In-Cell (PIC) simulations of the interaction between EM waves and space charges.

At the end of November 1998, the P.I. officially joined ODU and an agreement to transfer the funds of this grant from UTK to ODU was initiated. This was done in the form of a sub-grant from UTK to ODU, and Prof. Igor Alexeff was appointed as the UTK Principal Investigator (or the Technical point of contact for UTK).

Activities Covering the Period Dec. 1, 1998 to May 31, 2000

After joining Old Dominion University, the P.I. spent part of his time coordinating the task of transferring the research to his new laboratory. A sub-grant with the University of Tennessee was established, under which the funds to support a new graduate student were provided. The paperwork including the sub-grant document was completed by the end of March 1999. It took some time to recruit a student with an American citizenship. However during this initial period collaborative work between the P.I. and Prof. Alexeff on experiments involving the generation of atmospheric pressure plasma with a DC power source was progressing. A technical paper titled "A Steady-State One Atmosphere Uniform DC Glow Discharge Plasma" was presented at the IEEE International Conference on Plasma Science which was held in June 1999 at Monterey, California. The abstract of the presentation is shown in the Appendix at the end of this document. Also in April 1999, the P.I. and Prof. Alexeff jointly presented a paper titled "Biological Applications of Non-Equilibrium Plasmas" at the 1st International Symposium on the Non-thermal Medical/Biological Treatments Using Electromagnetic Fields and Ionized Gases. A copy of the abstract of this paper is included in the Appendix (the funds supporting the attendance of the P.I. and Prof. Alexeff to the symposium were obtained from other sources than this grant).

In June 1999, an ODU student (Mr. Paul Richardson) was hired as a Research Assistant and supported by the funds of this sub-grant. After an initiation period during the summer of 1999, Mr. Richardson who has a background in biology started carrying out experiments on the biological decontamination of media by the "Resistive Barrier Discharge". The results of the work of Mr. Richardson were presented at the IEEE Int. Conf. On Plasma Science, which was held in New Orleans, LA, June 2000. The abstract of this presentation is included in the Appendix. Mr. Richardson's work concentrated on the identification of the biochemical pathways through which the plasma discharge affects the cells of microorganisms such as *Escherichia coli* and *Bacillus subtilis*.

Interactions:

Both the P.I. and the student have been interacting with Prof. K. H. Schoenbach's group at ODU who are also working on the generation of large volume, non-thermal plasmas. The P.I. has helped Prof. Schoenbach's group in the design and ordering of a microwave interferometer which allows the measurements of the electron number density in highly collisional plasmas. In addition, measurements of the background gas temperature in the GDAP were taken using the diagnostic facility developed by Prof. Schoenbach's group. These measurements were taken using a spectroscopic method based on the rotational structure of the second positive system of nitrogen. Comparison between measured spectra and simulated ones allows the determination of the temperature. Temperatures in the 350-370 K were measured. The P.I. along with Prof. Schoenbach's group presented their diagnostics work in an invited paper at the 1999 IEEE International Conference on Plasma Science, and in the 14th International Symposium on Plasma Chemistry held in Prague, Czech Republic, August 1999. The

funds which supported the travel of the P.I. to this symposium came out of other sources than this grant. A copy of the abstract and the full paper of the two above mentioned papers are included in the Appendix.

The P.I. also engaged in a collaborative effort with Prof. Alexeff of the University of Tennessee on the power considerations in the GDAP. They published a paper on this subject in the AIAA Proceeding of the 30th Plasmadynamics and Lasers Conference, held in June 1999, in Norfolk, Virginia. A copy of this manuscript is included in the Appendix.

Finally, the P.I. has attended most of the meetings of the Air Plasma Ramparts MURI Program, which is managed by AFOSR in cooperation with DDR&E.

Technical Description

Under this grant the students helped design, build, and test two methods to generate non-thermal, large volume, atmospheric pressure plasmas. The first method was based on the dielectric barrier discharge (DBD). Using the DBD configuration and applying a low frequency RF power (kV at kHz) and using helium as a carrier gas, a diffuse Glow Discharge at Atmospheric Pressure was achieved. Figure 1 and Figure 2 show the schematic and a photo of the discharge respectively. This discharge was used to carry out investigations on the potential of the GDAP to kill microorganisms. The results of these investigations were published in the IEEE Transactions on Plasma Science, Vol.27, No.1 (shown in the Appendix). Also a numerical treatment of the attenuation of microwaves by atmospheric plasma layers was developed, and the results published in the International Journal of Infrared and Millimeter Waves, Vol. 19, No.3 (shown in the Appendix).

Another method to generate non-thermal, large volume, atmospheric pressure plasmas was also developed. It is based on the "Resistive Barrier Discharge". The resistive barrier discharge relies on a high resistivity layer covering the metal electrodes to prevent the transition of a diffuse discharge to an arc discharge. A schematic and a photo of the discharge are shown in Figure 3 and Figure 4 respectively. This discharge which can be driven by DC or AC sources was used for the study of the interaction of plasma with the cells of microorganisms. The results of these experiments, shown in the Appendix, were presented at the IEEE International Conference on Plasma Science, held in June 2000 in New Orleans, LA (Abstract shown in Appendix)

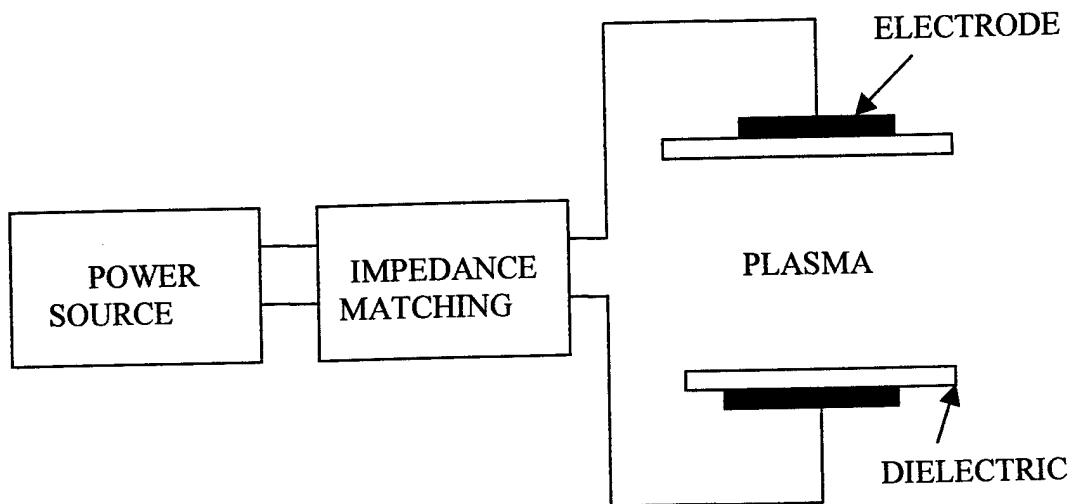

Fig. 1 Configuration of the Glow Discharge at Atmospheric Pressure (GDAP)

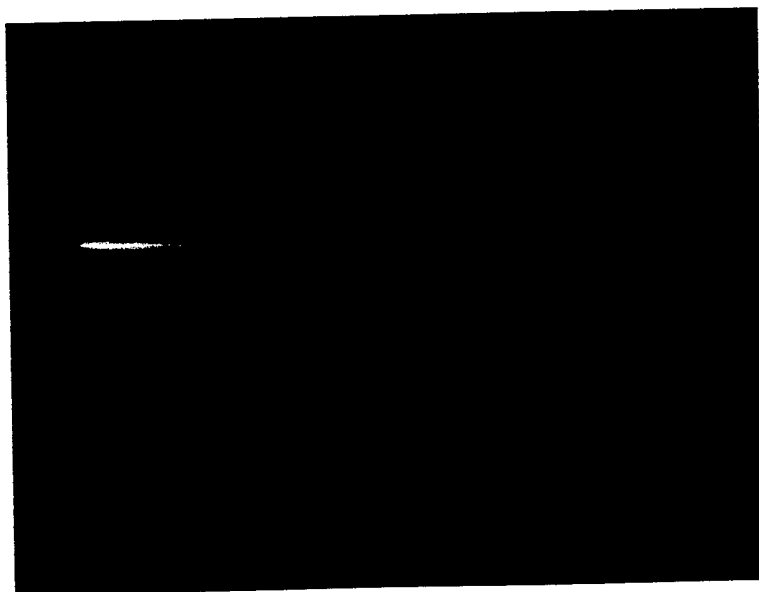

Fig. 2 Photo of the GDAP discharge

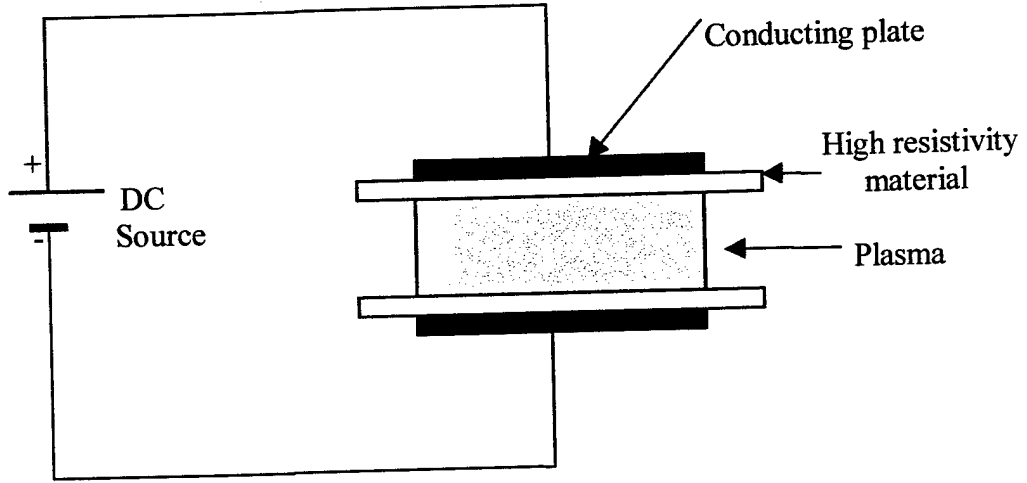

Fig. 3a DC driven Resistive Barrier Discharge (RBD) at Atmospheric Pressure

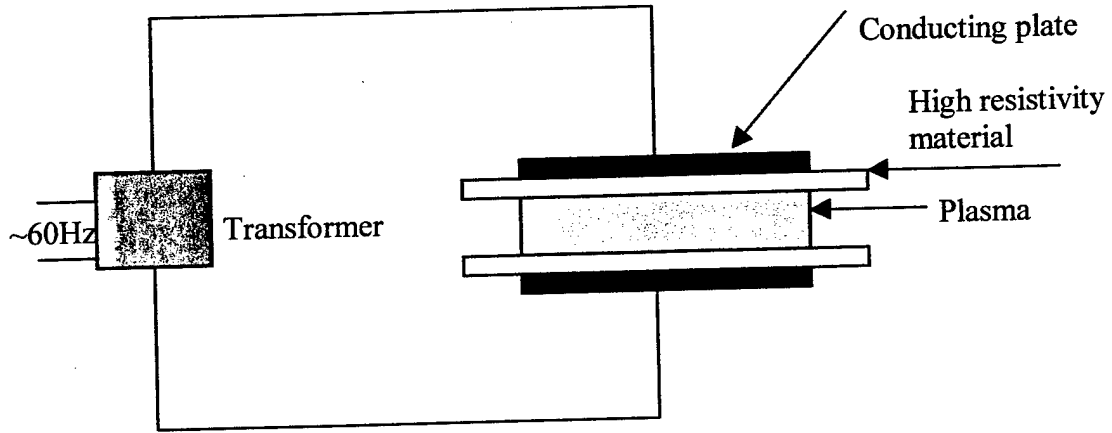

Fig. 3b AC (60 Hz) Driven RBD at Atmospheric Pressure

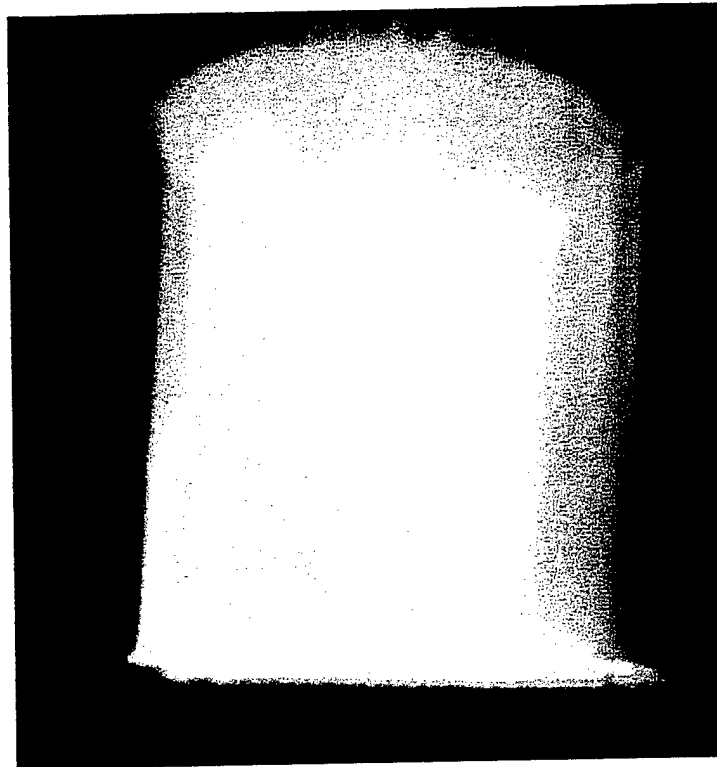

Fig. 4 Photo of the RBD discharge

References

- [1] M. Laroussi, "Interaction of Microwaves with Atmospheric Pressure Plasmas", *Int. J. IR & Millimeter Waves*, Vol. 16, No. 12, pp. 2069-2083, 1995.
- [2] E. Koretzky, and S. P. Kuo, "Characterization of an Atmospheric Pressure Plasma Generated by a Plasma Torch Array", *Phys. Plasmas*, Vol. 5, No. 10, pp. 3774-3780, 1998.
- [3] M. Laroussi, "Sterilization of Contaminated Matter with an Atmospheric Pressure Plasma", *IEEE Trans. Plasma Sci.*, Vol. 24, No. 3, pp. 1188-1191, 1996.

[4] J. Birmingham and P. Irving, " Corona Discharge Plasma Reactor for Decontamination", In Proc. IEEE Int. Conf. Plasma Sci., p. 183, 1998.

[5] S. Kanazawa, M. Kogoma, T. Moriwaki, and S. Okazaki, " Stable Glow Plasma at Atmospheric Pressure", J. Phys. D: Appl. Phys., Vol. 21, pp. 838-840, 1988.

[6] A El-Habachi and K. Schoenbach, " Generation of Intense Excimer Radiation from High Pressure Hollow Cathode Discharges", Appl. Phys. Lett., Vol. 73, No. 7, pp.885-887, 1998.

[7] R. Block, M. Laroussi, and K. H. Schoenbach, " Test facility for High Pressure Plasmas", In Proc. IEEE Int. Conf. Plasma Sci., Monterey, CA, 1999.

Personnel

The following is a list of the staff directly involved in the research efforts conducted under the scope of this work. Only the students were financially supported by the funds of this grants.

Dr. Mounir Laroussi, P.I.

Dr. Igor Alexeff (UTK Technical Contact for the sub-grant)

Mr. William T. Anderson (GRA, UTK)

Mr. Chad M. Malott (Under Grad Assistant, UTK)

Mr. J. Paul Richardson (GRA, ODU).

APPENDIX

Abstracts and archival publications

ATTENUATION OF ELECTROMAGNETIC WAVES BY A PLASMA LAYER AT ATMOSPHERIC PRESSURE

Mounir Laroussi and William T. Anderson

*Electrical Engineering Department
The University of Tennessee
Knoxville, Tennessee 37996-2100*

Received December 16, 1997

Abstract

Plasma layers at atmospheric pressure, are good broad band absorbers of electromagnetic radiation. However, to get substantial attenuations, two parameters have to be optimized. These are the plasma number density, and the thickness of the plasma layer. It is found that in order to be an effective attenuator of microwave radiation, a plasma layer has to have a number density in the 10^{13} cm⁻³ range, and a thickness equal or larger than the wavelength of the incident wave. However, as the frequency increases, the amount of attenuation tends to reach a limiting value directly proportional to the number density.

Key words: Plasma, Layer, Attenuation, Microwave, Atmospheric pressure.

I. Introduction

Plasmas at atmospheric pressure are highly collisional. Unlike low pressure plasmas, their refractive index is greater than unity across a frequency band in the microwave range, and no sharp propagation cut-off at intermediate frequencies is observed [1]. Consequently, if a wave travels through a layer of plasma at atmospheric pressure, it undergoes some level of absorption regardless if its frequency is below or above the plasma frequency. At frequencies higher than a characteristic frequency

$\omega_s = \frac{\omega_{pe}^2}{\nu}$ (where ω_{pe} is the plasma frequency and ν the collision frequency) the reduction in the magnitude of the transmitted wave is more due to absorption, through collisional momentum transfer, than to reflection or scattering of the incident wave [2]. However, only number densities at or above 10^{13} cm^{-3} result in substantial attenuation magnitudes. It is also found that although the thickness of the plasma layer is important, the attenuation ultimately reaches a saturation plateau, at high frequencies. The dB value of the attenuation corresponding to the plateau is directly proportional to the plasma number density, and to the thickness of the plasma layer.

II. Total Attenuation

Figure 1 illustrates the case of a wave propagating through air, then encountering a layer of uniform air plasma, of thickness d . The grazing angle is defined as $\Psi = 90^\circ - \theta_i$, where θ_i is the incident angle. It is assumed that the plasma is a lossy dielectric, and the thickness of the plasma layer is comparable or larger than the wavelength of the incident wave. After undergoing some reflection and scattering, the wave is further attenuated as it crosses the plasma layer. The transmitted wave emerges from the air plasma layer with a substantially reduced field.

As was shown in previous work [1] - [5], atmospheric pressure plasmas are highly collisional, and good broad

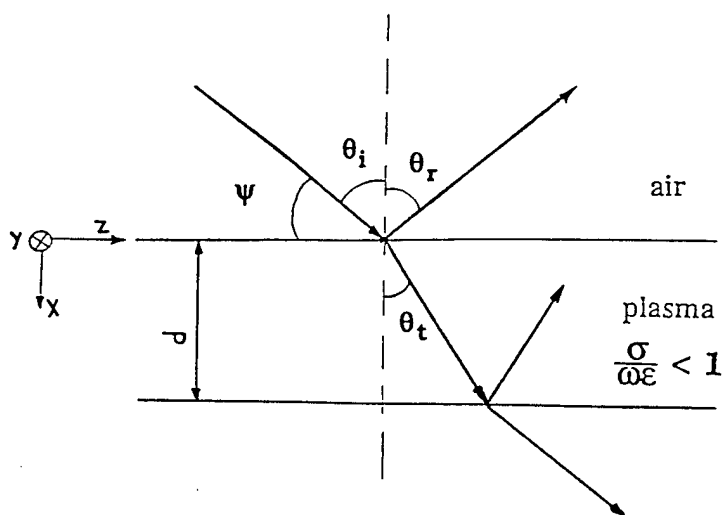

Fig. 1 Wave propagating through air, then an air plasma layer.

band absorbers. Their refractive index, μ , and their attenuation index, X , can be expressed as [2], [6],

$$\mu = \left\{ \frac{1}{2} + \frac{1}{2} \left[1 + \left(\frac{\omega_s}{\omega} \right)^2 \right]^{1/2} \right\}^{1/2}, \quad (1)$$

and

$$X = \left\{ -\frac{1}{2} + \frac{1}{2} \left[1 + \left(\frac{\omega_s}{\omega} \right)^2 \right]^{1/2} \right\}^{1/2}, \quad (2)$$

where the frequency ω_s is given by

$$\omega_s = \frac{\omega_{pe}^2}{\nu}, \quad (3)$$

where ω_{pe} is the plasma frequency, and ν is the collision frequency ($\nu \sim 1$ THz). The attenuation coefficient, α , is given by

$$\alpha = \frac{\omega}{c} X, \quad (4)$$

where ω is the wave frequency, and c the speed of light.

An electromagnetic wave crossing a uniform layer of atmospheric pressure plasma of thickness d , will have its field attenuated by a factor, T , given by

$$T = \text{Exp} \left(-\alpha \frac{d}{\cos \theta_t} \right), \quad (5)$$

where θ_t is the transmission angle. Using snell's law, the angle θ_t can be expressed as a function of the refractive index, and the grazing angle as follows

$$\theta_t = \sin^{-1} \left(\frac{\cos \psi}{\mu} \right). \quad (6)$$

For frequencies much higher than ω_S ($\omega \gg \omega_S$) the attenuation index, X , and the attenuation coefficient, α , can be approximated by [1]

$$X = \frac{ne^2}{4\pi\epsilon_0 m v f}, \quad (7)$$

and

$$\alpha = \frac{ne^2}{2\epsilon_0 m c v}, \quad (8)$$

where $\omega_{pe}^2 = \frac{ne^2}{m\epsilon_0}$ was used.

III. Data Analysis

Figure 2 shows the total attenuation, T , in dB, versus the wave frequency, for plasma number densities in the 10^{12} cm^{-3} range, and a plasma layer thickness of 3 cm. It can be easily concluded that attenuation reaches a substantial level only when the plasma number density, n , approaches 10^{13} cm^{-3} . Figure 3 and Figure 4 further emphasize this fact. Also, as predicted by Equation (8), for

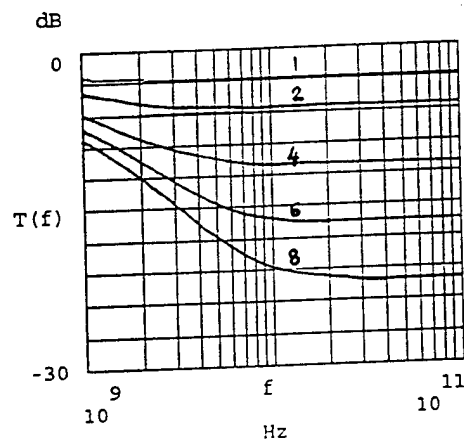

Fig. 2 Total attenuation (in dB) versus frequency (in Hz) for a grazing angle $\Psi = 30^\circ$, a layer thickness $d = 3$ cm, and 1. $n = 10^{12} \text{ cm}^{-3}$; 2. $n = 2 \cdot 10^{12} \text{ cm}^{-3}$; 4. $n = 4 \cdot 10^{12} \text{ cm}^{-3}$; 6. $n = 6 \cdot 10^{12} \text{ cm}^{-3}$; 8. $n = 8 \cdot 10^{12} \text{ cm}^{-3}$.

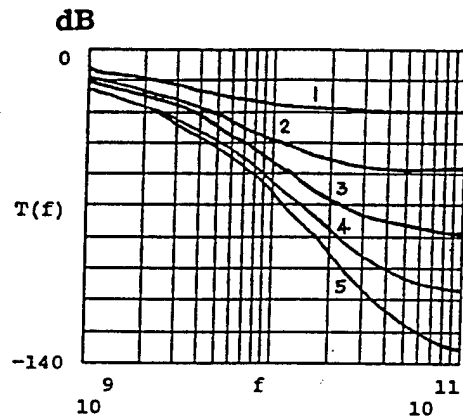

Fig. 3 Total attenuation (in dB) versus frequency (in Hz) for a grazing angle $\Psi = 30^\circ$, a layer thickness $d = 3$ cm, and 1. $n = 10^{13} \text{ cm}^{-3}$; 2. $n = 2 \cdot 10^{13} \text{ cm}^{-3}$; 3. $n = 3 \cdot 10^{13} \text{ cm}^{-3}$; 4. $n = 4 \cdot 10^{13} \text{ cm}^{-3}$; 5. $n = 5 \cdot 10^{13} \text{ cm}^{-3}$.

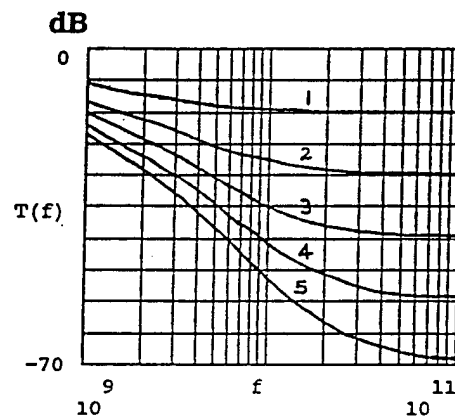

Fig. 4 Total attenuation (in dB) versus frequency (in Hz) for a grazing angle $\Psi = 90^\circ$, a layer thickness $d = 3$ cm, and 1. $n = 10^{13} \text{ cm}^{-3}$; 2. $n = 2 \cdot 10^{13} \text{ cm}^{-3}$; 3. $n = 3 \cdot 10^{13} \text{ cm}^{-3}$; 4. $n = 4 \cdot 10^{13} \text{ cm}^{-3}$; 5. $n = 5 \cdot 10^{15} \text{ cm}^{-3}$.

$\omega \gg \omega_s$ the level of attenuation becomes independent of the wave frequency, and directly proportional to the plasma number density. Figure 3 shows that as the number density reaches the 10^{13} cm^{-3} range, attenuation increases to high levels. For example, at $f = 10 \text{ GHz}$ ($\lambda = d = 3 \text{ cm}$) the incident power is attenuated by about 60 dB at $n = 5 \cdot 10^{13} \text{ cm}^{-3}$. However as the frequency increases and the wavelength becomes shorter than the plasma layer thickness, the attenuation reaches values up to 130 dB at $f = 100 \text{ GHz}$. Figure 4 shows that at normal incidence, the wave is less attenuated than oblique incidence, since it travels a shorter distance through the plasma. This fact is better illustrated by Fig. 5, which shows that at low grazing angles, the attenuation is substantially higher. Under this condition the wave also undergoes increased reflection [1] - [3].

Figure 6 shows the importance of the thickness of the plasma layer for increased attenuations. This is especially significant, since the attenuation saturates at higher frequencies, which renders its value independent on the d/λ ratio. However, for a fixed frequency, the dB value of the attenuation is directly proportional to the plasma layer thickness.

IV. Conclusion

This paper showed that if a plasma layer at atmospheric pressure is to be used as an attenuator of electromagnetic waves, two parameters have to be optimized: The plasma number density, and the thickness of the plasma layer. If the number density, n , is in the low 10^{12} cm^{-3} range, the plasma is practically transparent to microwaves at frequencies higher than the characteristic frequency ω_s . Only when n approaches and surpasses 10^{13} cm^{-3} would substantial attenuation occur. However, the thickness of the plasma layer has to be at least comparable

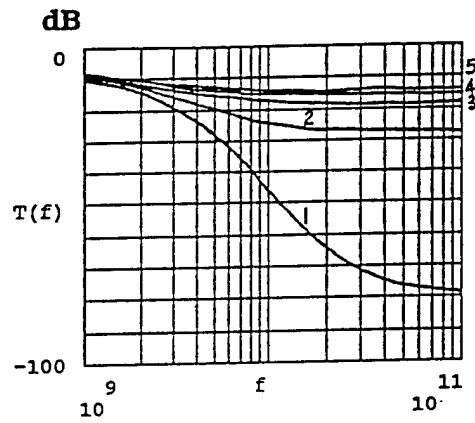

Fig. 5 Total attenuation (in dB) versus frequency (in Hz) for $n = 10^{13} \text{ cm}^{-3}$, a layer thickness of $d = 3 \text{ cm}$, and 1. $\Psi = 10^\circ$; 2. $\Psi = 30^\circ$; 3. $\Psi = 50^\circ$; 4. $\Psi = 70^\circ$; 5. $\Psi = 90^\circ$.

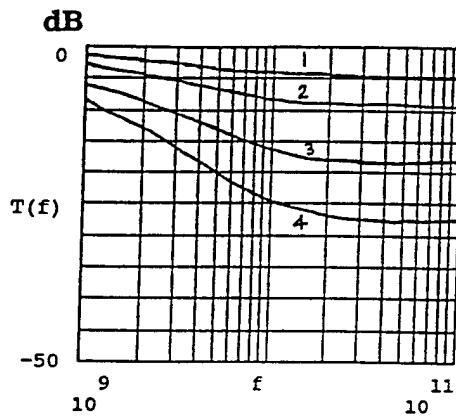

Fig. 6 Total attenuation (in dB) versus frequency (in Hz) for a grazing angle $\Psi = 30^\circ$, $n = 10^{13} \text{ cm}^{-3}$, and a layer thickness of 1. $d = 0.5$ cm; 2. $d = 1$ cm; 3. $d = 2$ cm; 4. $d = 3$ cm.

to the wavelength of the incident wave, if high attenuation values are to be maintained.

Acknowledgement

This work is supported by the Air Force Office of Scientific Research under contracts F49620-95-0277, and F49620-97-1-0472.

References

- [1] M. Laroussi, "Interactions of Microwaves with Atmospheric Pressure Plasmas", *Int. J. of Infrared and Millimeter Waves*, Vol. 16, No. 12, pp. 2069-2083, 1995.
- [2] M. Laroussi, "Interaction of An Air Plasma Layer Covering a Conducting Surface with Microwaves", in *Proc. 1997 IEEE ICOPS*, p. 135.
- [3] M. Laroussi, "Studies of the Reflectivity and Scattering of the One Atmosphere Glow discharge Plasma", in *Proc. 1996 IEEE ICOPS*, p. 294.
- [4] M. Laroussi, "Scattering of Electromagnetic Waves by a Layer of Air Plasma Surrounding a Conducting Cylinder", *Int. J. of Infrared and Millimeter Waves*, Vol. 17, No. 12, pp. 2215-2232, 1996.
- [5] R. J. Vidmar, "On the Use of Atmospheric Pressure Plasmas as Electromagnetic Reflectors and Absorbers", *IEEE Trans. Plasma Sci.*, Vol. 18, pp. 733-741, 1990.
- [6] M. A. Heald and C. B. Wharton, "Plasma Diagnostics with Microwaves", Krieger Pub., New York, 1978.

Images of Biological Samples Undergoing Sterilization by a Glow Discharge at Atmospheric Pressure

Mounir Laroussi, *Senior Member, IEEE*, Gary S. Sayler, Battle B. Glascock, Bruce McCurdy, Mary E. Pearce, Nathan G. Bright, and Chad M. Malott

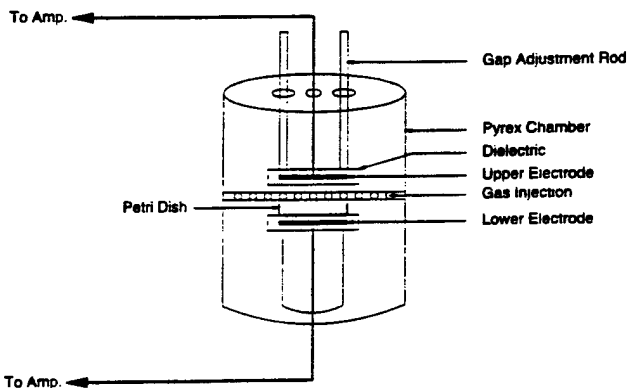

Fig. 1. Experimental setup of the glow discharge at atmospheric pressure (GDAP).

Abstract—Among the various industrial uses of the glow discharge at atmospheric pressure (GDAP), biological applications such as sterilization are under investigation. In this paper, we present images of a liquid medium (Luria-Bertani broth with tetracycline) contaminated by *Escherichia coli* bacteria (strain PBR 322) undergoing plasma treatment. In most cases, it is found that an exposure time of two to 20 minutes leads to nearly a complete kill of a 10^8 /ml *E. coli* population. The treatment time necessary to obtain a complete kill depends on the plasma power density, the type of gas used, the type of bacteria, and the type of medium.

Index Terms—Bacteria, decontamination, glow discharge, plasma, sterilization.

THE glow discharge at atmospheric pressure (GDAP) is a dielectric barrier controlled discharge. It is made of a chamber containing two electrodes, at least one of which is insulated by a dielectric material (see Fig. 1). An ac voltage of a few hundred volts to a few kilovolts, at a frequency of a few kilohertz applied between the two electrodes generates a uniform glow discharge [1], [2]. Various gases can be used, but the most uniform stable discharge is obtained when helium

Manuscript received June 16, 1998; revised September 28, 1998. This work was supported by AFOSR STTR under Contract F49620-97-C-0074.

M. Laroussi was with the Microwave and Plasma Laboratory, University of Tennessee, TN USA. He is now with the Applied Research Center, Old Dominion University, Newport News, VA 23606 USA (e-mail: laroussi@jlab.org).

G. S. Sayler, M. E. Pearce, and N. G. Bright are with the Center for Environmental Biotechnology, University of Tennessee, Knoxville, TN 37996 USA.

B. B. Glascock and B. McCurdy are with General Thermal Inc., Chattanooga, TN 37404 USA.

C. M. Malott is with the Microwave and Plasma Laboratory, University of Tennessee, Knoxville, TN 37996 USA.

Publisher Item Identifier S 0093-3813(99)02583-7.

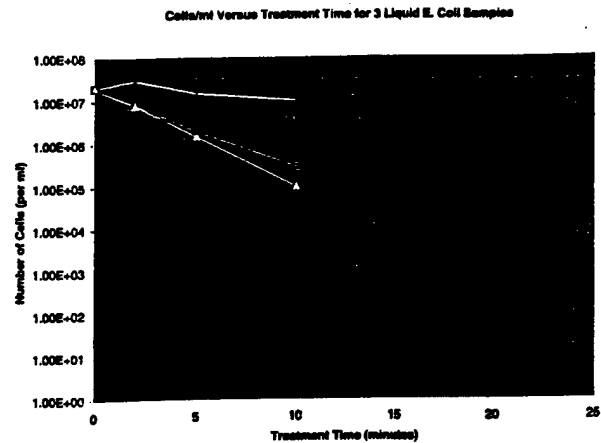

Fig. 2. *E. coli* live-cells number versus exposure time: r1, r2, and r3 are three samples treated under the same plasma conditions, and the Control is a similar untreated sample.

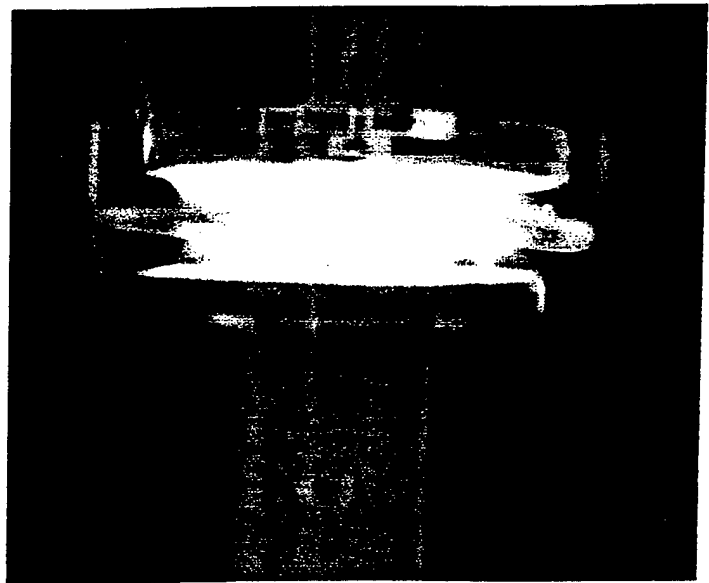
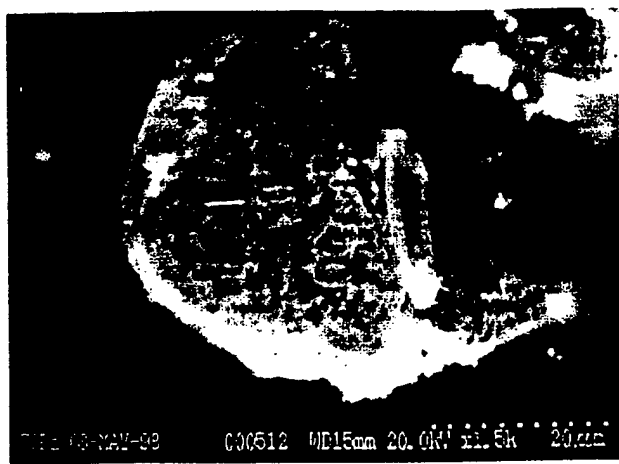

Fig. 3. Photograph of the discharge. The electrodes are insulated copper disks, 10 cm in diameter, and the gap distance is 3 cm.

is the main component of the gas mixture. The gap distance between the electrodes can vary from a few millimeters to a few centimeters. The discharge current is a pulse each half cycle of the applied voltage. This is due to charge accumulation on the dielectric, which prevents the transition of the discharge to an arc. However, unlike the silent discharge which is made of a large number of filamentary discharges, and which exhibits a current with multiple sharp pulses each



(a)



(b)

Fig. 4. (a) SEM photograph of an *E. coli* bacterium in the untreated control sample. (b) Appearance of *E. coli* cells after 30 seconds exposure to the plasma.

half cycle, the current pulse of a stable and uniform GDAP is a single pulse per half cycle, with a slow decay time. The slow decay of the current is due to the metastable states of helium, which can ionize other atoms after the initial breakdown of the gas mixture [3]. The discharge, therefore, displays a uniform glow throughout the gap between the electrodes. The plasma power density is in the 50–100 mW/cm³ range.

The GDAP has recently been used for various applications, such as surface modification [1], [4] and biological applications [5]. Since this discharge is of the nonequilibrium type, the neutrals, ions, and electrons have different temperatures. The electrons are much hotter than the ions, with kinetic temperature in the 1–5 eV range. This is a perfect range for the breaking of chemical bonds [6], which leads to the generation of chemically reactive free radicals. The free radicals along with the ultraviolet radiation generated by the discharge interact with the cells of the microorganisms at the molecular and atomic levels causing cell damage or death depending on the exposure time. Fig. 2 shows the case of three liquid samples (r_1 , r_2 , and r_3) containing 3×10^7 /ml of *E. coli* bacteria. After a plasma exposure time of ten minutes, a reduction of two orders of magnitude in the population of *E. coli* is observed in the three samples. A plasma treatment of 20 minutes of sample r_1 reduces the population of *E. coli* to approximately 300/ml, a reduction of five orders of magnitude. Fig. 3 is a photograph of the discharge as it appears during our experimental runs. A helium and air mixture is used. For liquid samples, the best results are obtained when the plasma comes in direct contact with the liquid. Fig. 4(a) is a scanning electron microscope (SEM) photograph of an *E. coli* bacterium living in the control sample (untreated). Fig. 4(b) shows *E. coli*

cells after 30 seconds exposure to plasma. Unlike the cells of Fig. 4(a), the treated cells lost their rounded shape and appear to be in the process of losing internal matter. This leads us to the conclusion that the outer membrane of the cells must have been punctured during its exposure to the plasma. With a damaged outer membrane, the cells become very vulnerable to the surrounding plasma environment, which contains active species capable of causing lethal reactions within the cells.

ACKNOWLEDGMENT

The authors would like to thank Prof. D. C. Joy for his help with the scanning electron microscope and Prof. I. Alexeff for taking the double exposure photograph of the discharge with his camera.

REFERENCES

- [1] S. Kanazawa, M. Kogoma, T. Moriwaki, and S. Okazaki, "Stable glow plasma at atmospheric pressure," *J. Phys. D, Appl. Phys.*, vol. 21, pp. 838–840, 1988.
- [2] J. R. Roth, M. Laroussi, and C. Liu, "Experimental generation of a steady-state glow discharge at atmospheric pressure," in *Proc. IEEE Int. Conf. Plasma Sci.*, Tampa, FL, 1992, pp. 170–171.
- [3] F. Massines, A. Rabehi, P. Descombes, R. BenGadri, P. Segur, and C. Mayoux, "Experimental and theoretical study of a glow discharge at atmospheric pressure controlled by dielectric barrier," *J. Appl. Phys.*, vol. 83, no. 6, pp. 2950–2957, 1998.
- [4] F. Massines, C. Mayoux, R. Messaoudi, A. Rabehi, and P. Segur, "Experimental study of an atmospheric pressure glow discharge: Application to polymers surface treatment," in *Proc. Int. Conf. Gas Discharges & Their Applicat.*, Swansea, U.K., 1992, pp. 730–733.
- [5] M. Laroussi, "Sterilization of contaminated matter with an atmospheric pressure plasma," *IEEE Trans. Plasma Sci.*, vol. 24, pp. 1188–1191, June 1996.
- [6] B. Eliasson and U. Kogelschatz, "Nonequilibrium volume plasma chemical processing," *IEEE Trans. Plasma Sci.*, vol. 19, pp. 1063–1077, Dec. 1991.

LAWSON SV

ICOPS99

International Conference on Plasma Science

IEEE CONFERENCE RECORD - ABSTRACTS

**1999 IEEE INTERNATIONAL CONFERENCE
ON PLASMA SCIENCE**



***The 26th
IEEE International
Conference on
Plasma Science***

**June 20-24, 1999
Monterey California, USA**

**Sponsored by:
The Plasma Science &
Applications Committee
of the
IEEE Nuclear & Plasma Sciences Society**

**Co-Sponsors:
Sandia National Laboratories
Los Alamos National Laboratory
Defense Threat Reduction Agency**

4P21

A Steady-State One Atmosphere Uniform DC Glow Discharge Plasma

Igor Alexeff, Mounir Laroussi, Weng Lock Kang and Ali Alikafesh, University of Tennessee, Knoxville, TN 37996-2100, USA



A Steady-State One Atmosphere Uniform DC Glow Discharge Plasma

Igor Alexeff, Mounir Laroussi¹, Weng Lock Kang, and Ali Alikafesh; University of Tennessee.

We have produced a one-atmosphere DC glow discharge plasma with a density (so far) of 10^{11} /cm³. The basic discovery is twofold: First, we have found a theorem that shows that any complex AC geometry containing materials of varying dielectric constant can be replaced by a DC system containing materials of varying electrical conductivity. The geometries of the electric field lines are identical, as long as the varying permittivity in the AC system is matched by the varying conductivity in the DC system: Second, we have found a suitable electrode material for the DC case that replaces the dielectric-coated metal electrodes for the AC case. This new electrode material is inexpensive and robust. This new material is presently proprietary (A patent is pending.), but is to be discussed at ICOPS. In addition, we intend to present photographs of the apparatus in operation, as well as samples of the new electrode material.

The advantages of a DC system over an AC system are that it is less expensive and more efficient, as no RF power supply is necessary. Actually, 60 Hz line power can also be used, and a simple neon sign transformer suffices for experimental work. This plasma can be used for chemical and biological decontamination, as well as surface modification.

¹ Present address: Applied Research Center, Old Dominion University.

4P22

Effects of Non-Equilibrium Plasmas on Microorganisms

Mounir Laroussi, Igor Alexeff, Old Dominion University, Newport News, VA 23606, USA

Effects of Non-Equilibrium Plasmas on Microorganisms

Mounir Laroussi
Applied Research Center
Old Dominion University
12050 Jefferson Ave.
Newport News, VA 23606

Igor Alexeff
Microwave & Plasma Laboratory
The University of Tennessee
Knoxville, TN 37996-2100

Abstract

Non-equilibrium plasmas have been shown to be excellent sterilization agents [1]-[3]. Garate & Alexeff used a corona discharge, and Laroussi & Saylor used an R.F. driven glow discharge. Also, most recently Alexeff & Laroussi have been able to generate a glow discharge at atmospheric pressure using a DC power source. The use of R.F. and DC driven discharges showed that a large population ($\sim 10^8$ per ml) of harmful microorganisms can be neutralized after a few minutes exposure to the plasma. The optimum exposure time is dependent on the type of microorganism, the medium supporting the microorganism, the plasma power density, and the gas mixture used in the discharge [3]. However, the biophysical and biochemical effects leading to the death of the cells of the microorganisms are yet to be understood. In this paper, we discuss the various factors, which play an active role in the cell-plasma interaction.

[1] M. Laroussi "Sterilization of Contaminated Matter with an Atmospheric Pressure Plasma", IEEE Trans. Plasma Sci., Vol.24, No.3, pp. 1188-1191, 1996.

[2] E. Garate et al. "Atmospheric Plasma Induced Sterilization and Chemical Neutralization", in Proc. IEEE Int. Conf. Plasma Sci., p. 183, 1998.

[3] M. Laroussi et al. "Images of Biological Samples Undergoing Sterilization by a Glow Discharge at Atmospheric Pressure", IEEE Trans. Plasma Sci. Special Issue on Images in Plasma Sci., Vol.27, No.1, 1999.

**First International Symposium on
Nonthermal Medical/Biological Treatments Using Electromagnetic
and Ionized Gases**

ORGANIZING COMMITTEE

Chairman: Karl H. Schoenbach
Old Dominion University

Co-Chairmen: Robert J. Barker
U.S. Air Force Office of Scientific Research

Shenggang Liu
University of Electronic Science and
Technology of China

PROGRAM COMMITTEE

Hidenori Akiyama	Kumamoto, U. Japan
Robert Barker	U.S. Air Force Office of Scientific Research
Stephen Beebe	Eastern Virginia Medical School
Klaus Frank	U. Erlangen, Germany
Ben Greenbaum	U. of Wisconsin
S. Liu	U. Electronic Science and Technology of China
D. Manos	College of William and Mary
C. Polk	U. of Rhode Island
E. Postow	National Institutes of Health
K. Schoenbach	Old Dominion University

BIOLOGICAL APPLICATIONS OF NON-EQUILIBRIUM PLASMAS

I. Alexeff

Microwave & Plasma Laboratory, The University of Tennessee

M. Laroussi

Applied Research Center, Old Dominion University

W. Kang and C. M. Malott

Microwave & Plasma Laboratory, The Univ. of Tennessee

Corona discharges [1], [2], and R.F. driven glow discharges at atmospheric pressure [3] [4] have been shown to be effective means of biological decontamination. R.F. discharges such as the Glow Discharge at Atmospheric Pressure [5] have the advantage of producing large volume plasmas, but require expensive and bulky power supplies capable of producing several kilovolts at frequencies of few kilohertz (audio frequencies). These high voltage audio frequency supplies are not only expensive but are usually not available off-the-shelf, and can be quite noisy and radiate power. Recently, Alexeff and co-workers solved this problem by producing a large volume glow discharge at atmospheric pressure using a DC or 60 Hz power source. The use of a DC or 60 Hz supply makes this discharge more practical and much less expensive than the R.F. driven discharge.

The use of R.F. and DC driven discharges showed that a large population ($\sim 10^8$ per ml) of harmful microorganisms can be neutralized after a few minutes exposure to the plasma. The optimum exposure time is dependent on the type of microorganism, the medium supporting the microorganism (solid, liquid, slurry...), the plasma power density, and the gas mixture used in the discharge [4]. Scanning Electron Microscope microphotographs of plasma-treated bacteria show that the outer membrane of the microorganisms cells is punctured after only few seconds exposure to the plasma [4]. Free radicals, such as OH, atomic oxygen, and radiation generated in the discharge can therefore penetrate the cell and adversely alter its internal biochemistry. The presence of oxygen in the discharge gas mixture renders it more lethal. Plots of the live cells density versus exposure time show that, for similar plasma conditions, the kill rate depends strongly on the type of medium supporting the microorganisms.

[1] E. Garate et al. "Atmospheric Plasma Induced Sterilization and Chemical Neutralization", in Proc. IEEE Int. Conf. Plasma Sci., p. 183, 1998.

[2] J. G. Birmingham et al. "Corona Discharge Plasma Reactor for Decontamination", in Proc. IEEE Int. Conf. Plasma Sci., p.183, 1998.

[3] M. Laroussi "Sterilization of Contaminated Matter with an Atmospheric Pressure Plasma", IEEE Trans. Plasma Sci., Vol.24, No.3, pp. 1188-1191, 1996.

[4] M. Laroussi et al. "Images of Biological Samples Undergoing Sterilization by a Glow Discharge at Atmospheric Pressure", IEEE Trans. Plasma Sci. Special Issue on Images in Plasma Sci., Vol.27, No.1, 1999.

[5] S. Kanazawa et al. "Stable Glow Plasma at Atmospheric Pressure", J. Phys. D: Appl. Phys., 21, pp.838-840, 1988.

Larousser

ICOPS99

International Conference on Plasma Science

IEEE CONFERENCE RECORD - ABSTRACTS

**1999 IEEE INTERNATIONAL CONFERENCE
ON PLASMA SCIENCE**



***The 26th
IEEE International
Conference on
Plasma Science***

**June 20-24, 1999
Monterey California, USA**

**Sponsored by:
The Plasma Science &
Applications Committee
of the
IEEE Nuclear & Plasma Sciences Society**

**Co-Sponsors:
Sandia National Laboratories
Los Alamos National Laboratory
Defense Threat Reduction Agency**

2B

De Anza II

3 PM, Monday, June 21, 1999

Oral Session 2B

Microwave Plasmas

Chairperson

John Scharer

University of Wisconsin

2B01-2

Invited -

Test Facility for High Pressure Plasmas

Rolf Block, Mounir Laroussi & Karl H. Schoenbach, Old Dominion University, Norfolk, VA 23529, USA

Test Facility for High Pressure Plasmas*

Rolf Block, Mounir Laroussi, and Karl H. Schoenbach
Physical Electronics Research Institute/ Appl. Research Center
Old Dominion University, Norfolk/ Newport News, VA

High pressure nonthermal plasmas are gaining increasing importance because of their wide range of applications, e.g. in air plasma ramparts, gas processing, surface treatment, thin film deposition, and chemical and biological decontamination. In order to compare various methods of plasma generation with respect to efficiency, development of instabilities, homogeneity, lifetime etc., a central test facility for high pressure plasmas is being established.

The facility will allow us to study large volume ($> 100 \text{ cm}^3$), nonthermal (gas temperature: $< 2000 \text{ K}$) plasmas over a large pressure range (10^{-6} Torr up to more than 1 atmosphere) in a standardized discharge cell. The setup was designed to generate plasmas in air as well as in gas mixtures. The available voltage range extends to 25 kV dc (10 kW power). The electrodes can be water cooled.

Electrical diagnostics include a 400 MHz, 2 GS/s 4-channel oscilloscope for current and voltage measurements and the detection of the onset of instabilities.

For optical diagnostics, a CCD video camera is used to record the appearance of dc discharges. A high-speed light intensified CCD-camera (25 mm MCP with photocathode, gating speed: 200 ps, adjustable in 10 ps steps) allows to study the development of instabilities and can also be utilized in temporally resolved spectroscopic measurements.

Optical emission spectroscopy allows us to determine plasma parameters such as electron density (through Stark broadening measurements) and gas temperature measurements. We have particularly concentrated our efforts on gas temperature diagnostics. The rotational structure of the second positive system of nitrogen contains information on the neutral gas temperature, which is identical with the rotational temperature [1]. Taking the apparatus profile into account, the temperature of the rotational excited molecules is determined by a comparison of simulated and measured data. A spectrograph with an instrument profile of $\text{FWHM}=0.1 \text{ \AA}$ is available.

Interferometry is well suited for electron density measurements especially in weakly ionized plasmas. A 4 mm microwave interferometer will be used for this diagnostics. Number densities up to $7 \cdot 10^{13} \text{ cm}^{-3}$ can be measured in this wavelength range. For higher densities we plan to use an IR interferometer with a CO_2 laser as source.

* Funded by the Air Force Office of Scientific Research in Cooperation with the DDR&E Air Plasma MURI Program.

[1] Rolf Block, Olaf Toedter and Karl H. Schoenbach, "Temperature Measurement in Microhollow Cathode Discharges in Atmospheric Air", Bull. APS 43, No. 6, NW1 2, p. 1478, 1998.

Proceedings

**14th INTERNATIONAL SYMPOSIUM ON
PLASMA CHEMISTRY**

Volume II

August 2 – 6, 1999

Edited by

M. Hrabovský, M. Konrád, and V. Kopecký

**INSTITUTE OF PLASMA PHYSICS
ACADEMY OF SCIENCES OF THE CZECH REPUBLIC**

OPTICAL DIAGNOSTICS FOR NON-THERMAL HIGH PRESSURE DISCHARGES

Rolf Block, Mounir Laroussi, Frank Leipold, and Karl H. Schoenbach
Physical Electronics Research Institute/Applied Research Center
Old Dominion University
12050 Jefferson Ave.
Newport News, VA 23606

Abstract

Two important parameters of high pressure, non-thermal plasmas are the gas temperature and the electron density. Optical emission spectroscopy and laser interferometry have been used to obtain these parameters in a dc atmospheric pressure hollow cathode discharge in air. Temperatures at and below 2000K and electron densities of approximately 10^{16} cm^{-3} have been measured. The two diagnostic methods are a subset of techniques developed to characterize non-thermal, high pressure plasmas in a newly established test facility at Old Dominion University.

1. Introduction

Non-thermal, high pressure plasmas have recently been used in novel emerging applications such as excimer light sources [1], surface modification of polymers [2], biological decontamination [3], and air plasma ramparts [4,5]. Each of these applications requires a specific set of plasma parameters. Diagnostic techniques applicable for high-pressure plasmas are required to adequately characterize the discharge. In this paper, we concentrate on a spectroscopic method, which yields information on the rotational structure of the second positive system of nitrogen for gas temperature measurement, and on interferometric methods using IR or microwave sources for electron density measurement. The experimental setups are presented, and results obtained on plasma generated with a microhollow cathode discharge are discussed.

2. Temperature Measurement

Optical emission spectroscopy allows us to determine plasma parameters such as electron density (through Stark broadening measurements) and gas temperature measurements. We have particularly concentrated on the gas temperature diagnostics in non-equilibrium plasmas in air. The rotational structure of the second positive system of nitrogen (transitions from the electronic

C-state to the B-state) contains information on the rotational temperature. Because of the low energies needed for rotational excitation and the short transition times, molecules in the rotational states and the neutral gas molecules are in equilibrium. Consequently, the rotational temperature provides also the value of the neutral gas temperature.

The 0-0 band of the second positive system of molecular nitrogen, modeled as a rigid rotor, has been simulated with the rotational temperature as variable parameter. In order to determine the plasma temperature, the simulated spectra are compared with the measured one. This comparison requires that the instrument profile (FWHM) of the spectrograph has to be taken into account. This is done by convoluting the computed line spectra with the appropriate Gauss function. Such simulated spectra for an FWHM=0.02nm are shown in fig. 1 for three temperatures [6]. The curves are shifted vertically for a better separation.

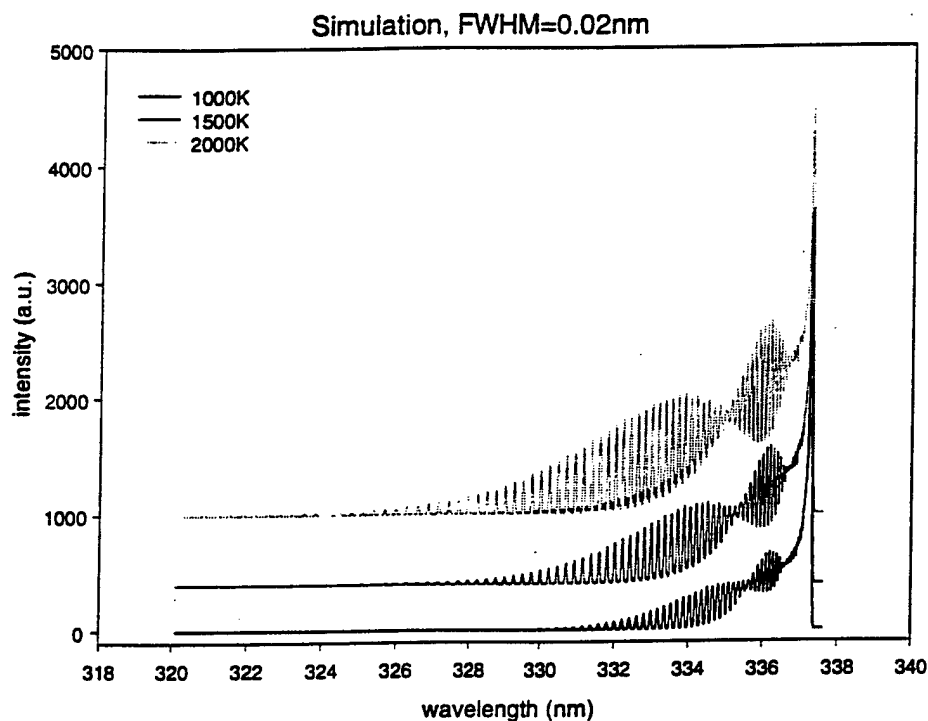

Fig. 1: Simulated spectra of molecular nitrogen

Generally, resolving the rotational structure requires a monochromator with very high resolution. A 0.5m imaging monochromator/spectrograph with a 3600 g/mm grating (with 240nm blaze wavelength) was used as dispersing element. Dual exit ports offer the versatility of mounting two different detectors at the same time. One exit port is equipped with an exit slit and a photomultiplier. The second port will be used for a fast light-intensified CCD-camera (25mm micro channel plate with photocathode, gating speed down to 200ps, adjustable in 100ps steps), which allows temporally resolved spectroscopic measurements.

Fig. 2 shows a measured spectrum of a microhollow cathode discharge (MHCD) in room air at atmospheric pressure. A MHCD is a direct current, high pressure glow discharge between two closely spaced electrodes, which contain circular openings [7]. The electrodes are separated by an insulator (mica or alumina). In this experiment we used 100 μ m thick molybdenum

electrodes, separated by a 125 μm thick sheet of alumina, with 100 μm holes. The dc voltage across the electrodes was 380V, the discharge current was 12mA. The instrument profile of the spectrograph was measured with a mercury lamp (line at 361nm) as FWHM=0.02nm. A comparison with simulated spectra resulted in a temperature of $T=1500\text{K}$.

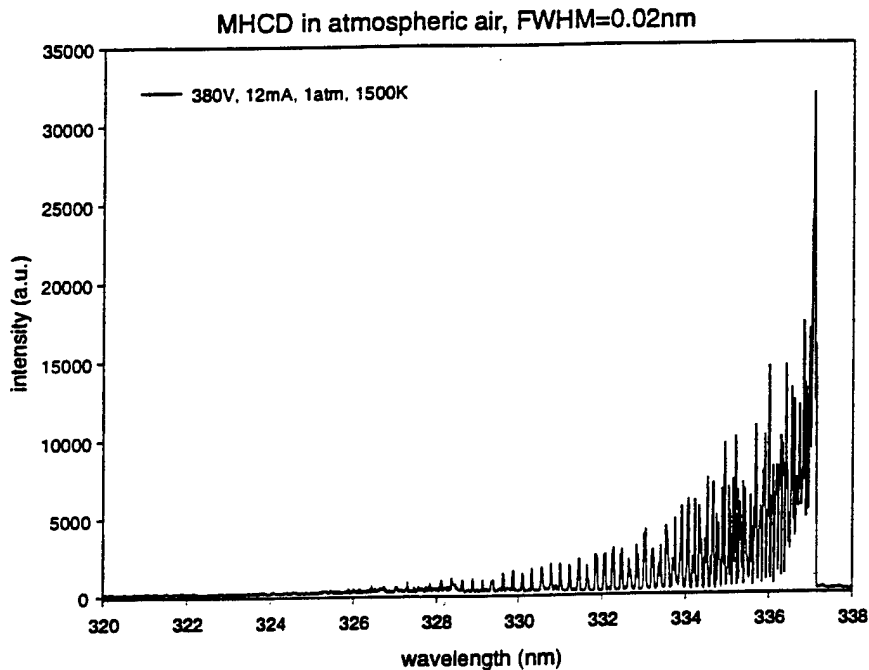

Fig. 2: Measured spectrum of a MHCD in atmospheric air.

The nitrogen line at 337.1nm (within the second positive system of nitrogen) is the line with the highest intensity and therefore easy to measure. This diagnostic can also be used in other gas mixtures, if the application allows the addition of small amounts of nitrogen.

3. Electron Density Measurement

3a. Infrared Interferometry

The interferometer is designed as a heterodyne Mach-Zehnder interferometer. The source is a CO_2 -laser operating at 10.6 μm . Figure 3 shows the experimental setup.

The laser beam is split in two beams. One beam passes through the plasma, while the second beam passes along a reference path, where it undergoes a frequency shift of 40 MHz applied by an acousto-optic modulator. Using a beam splitter, the two beams are allowed to interfere and produce two signals, only one of which has the beat frequency of 40 MHz. This signal is then compared to the driver signal of the acousto-optic modulator (which also has a frequency of 40 MHz). The phase shift is then converted to a voltage by a phase detector. The resolution of the interferometer was about 0.01 degree.

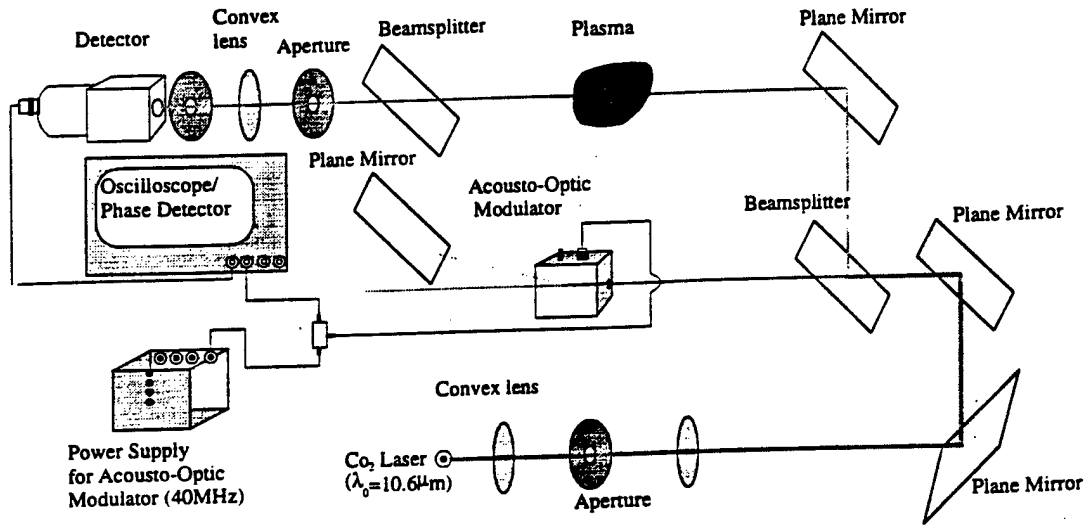

Fig. 3: IR-Interferometer for electron density measurement

The above-described technique is best applied to a pulsed system, with pulse repetition rate of few kilohertz. This enables the separation of the phase shift caused by the electrons from the phase shift caused by mechanical movement and thermal drifts. This method was applied to plasma generated by a microhollow cathode discharge in atmospheric pressure room air, using a sample with the same dimensions (100 μm thick molybdenum electrodes, separated by 125 μm thick alumina sheet, with 100 μm holes). The voltage between the electrodes was 390V, the discharge current was 12mA. The plasma was 100 μm wide and 400 μm long. Electron densities on the order of 10^{16} cm^{-3} were measured. In order to provide evidence that the laser does not affect the plasma in the micro cavity, experiments with varying laser intensity have been performed. Fig. 4 shows that the electron density measurements are independent of the laser beam power.

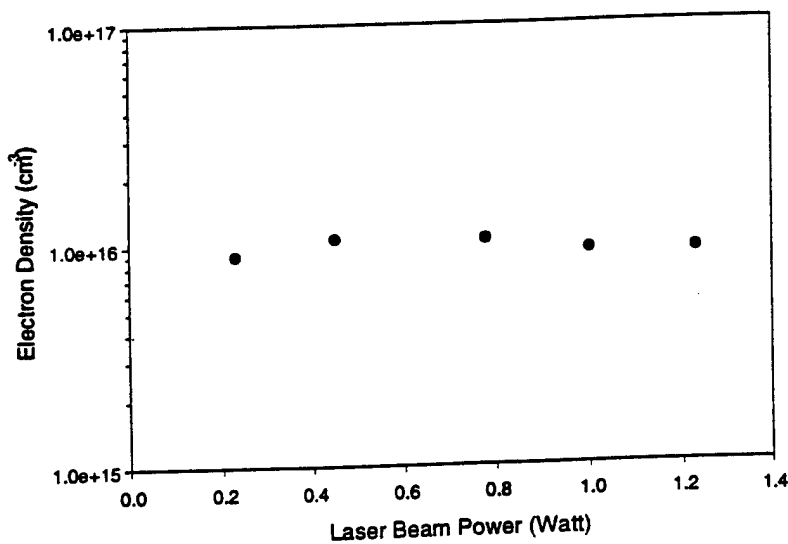

Fig. 4: Electron density versus laser beam power

3b. Microwave Interferometry

In order to extend the range of electron density measurements to lower values, a microwave interferometer is being developed. The increase in wavelength allows us to expand the diagnostic range down to 10^{12} cm^{-3} , however on the expense of spatial resolution. Figure 5 shows the interferometer design we adopted for our experiments.

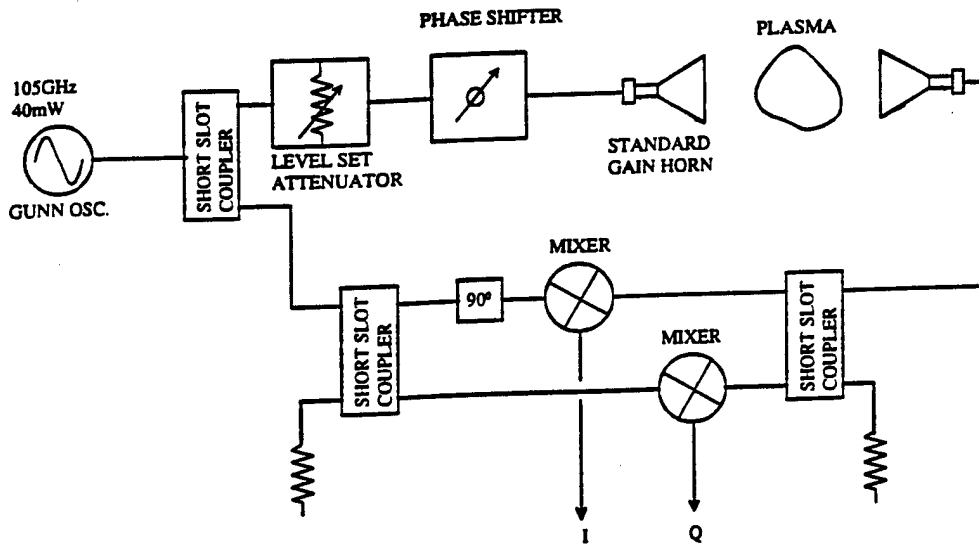

Fig. 5: Microwave Interferometer for number density measurement

The microwave interferometer, or phase bridge, shown above operates as follows. A microwave signal generated by a Gunn diode oscillator is divided in two equal portions by a Short Slot Coupler. One portion is transmitted through the plasma. The second portion is channeled to a second power divider which splits the signal to drive the LO input of the I-Q mixers. The signal transmitted by the plasma is also split in two portions, which drive the RF inputs of the I-Q mixers. Since both the LO and RF inputs of the mixers are at the same frequency, a DC signal is obtained at the IF output of the mixers. Calibration of the bridge is achieved by setting the Level Set Attenuator to the maximum attenuation position, measuring the DC offset of the mixers, varying the Phase Shifter through 360° , and recording the DC voltage at the IF output of the mixers. The measurement is repeated for varying level of attenuation. This set of data is then used to analyze actual phase shifts undergone by the microwave signal with the plasma ON. The accuracy of the measurement is determined by the resolution of the voltage measurements.

Conclusion

Spectroscopic measurements of the structure of the second positive system of nitrogen allow us to accurately determine the background gas temperature in nonthermal plasmas. Our method was used on a microhollow cathode discharge. Temperatures at and below 2000 K were measured. Infrared and microwave interferometry allow us to obtain information on the electron

number density over a wide range. Using the IR interferometer on a microhollow cathode discharge plasma, we measured electron densities close to 10^{16} cm⁻³. A specially designed microwave interferometer will allow us to measure electron densities down to about 10^{12} cm⁻³.

The diagnostic techniques presented in this paper are a part of a test facility for high pressure, non-thermal plasmas. This test facility allows to study large volume plasmas over a large pressure range in a standardized discharge cell. The facility also includes electrical (large bandwidth scopes for current-voltage measurements) and optical (high speed CCD camera to study the development of instabilities) diagnostics.

Acknowledgement

This work was funded by the US Air Force Office of Scientific Research in Cooperation with the DDR&E Air Plasma MURI Program.

References

- [1] Ahmed El-Habachi and Karl H. Schoenbach, "Generation of Intense Excimer Radiation from High-Pressure Hollow Cathode Discharges", *Appl. Phys. Lett.* **73**, (1998), 885.
- [2] F. Massines, C. Mayoux, R. Messaoudi, A. Rabehi, and P. Segur, "Experimental Study of an Atmospheric Pressure Glow Discharge: Application to Polymers Surface Treatment", *Proc. Int. Conf. Gas Discharges & their Applications*, 1992, 730.
- [3] M. Laroussi, "Sterilization of Contaminated Matter with an Atmospheric Pressure Plasma", *IEEE Trans. Plasma Sci.*, **24**, (1996), 1188.
- [4] M. Laroussi, "Interaction of Microwaves with Atmospheric Pressure Plasmas", *Int. J. IR & Millimeter Waves*, **16**, (1995), 2069.
- [5] Robert H. Stark and Karl H. Schoenbach, "A Novel Plasma Cathode for High Pressure Glow Discharges", *J. Appl. Phys.*, **85**, (1999), 2075.
- [6] Rolf Block, Olaf Toedter and Karl H. Schoenbach, "Temperature Measurement in Microhollow Cathode Discharges in Atmospheric Air", *Bull. APS*, **43**, October 1998, 1478.
- [7] Karl H. Schoenbach, Ahmed el-Habachi, Wenhui Shi and Marco Ciocca, "High Pressure Hollow Cathode Discharges", *Plasma Sources, Science and Technology*, **6**, (1997), 468.



AIAA 99-3667
Power Consideration in the
Glow Discharge at Atmospheric Pressure
M. Laroussi
Old Dominion University
Applied Research Center
Newport News, VA
and I. Alexeff
The University of Tennessee
Knoxville, TN

30th Plasmadynamics and Lasers Conference
28 June - 1 July, 1999 / Norfolk, VA

POWER CONSIDERATIONS IN THE GLOW DISCHARGE AT ATMOSPHERIC PRESSURE

Mounir Laroussi
Old Dominion University, Applied Research Center
Newport News, VA 23606

and
Igor Alexeff
The University of Tennessee
Knoxville, TN 37996

ABSTRACT

The Glow Discharge at Atmospheric Pressure (GDAP) is a dielectrical barrier controlled discharge. Recently, various industrial applications of this type of discharge have emerged. To better control the operation of the GDAP, a basic understanding of the relationship between the macroscopic parameters such as voltage and current, and the plasma parameters such as the number density, is very important. In this context the authors present new and interesting results based on an analytical model of the discharge which they developed. It is found that two modes of operation of the discharge exist. A "low frequency" mode ($f < 20$ kHz), and a "higher frequency" mode ($f > 20$ kHz). The higher frequency mode requires less applied input power to maintain a stable discharge with a comparable plasma number density as the "low frequency" mode. This result is of importance in applications where the power budget is an issue, and where lower applied voltages are desired.

Copyright © 1999 The American Institute of Aeronautics and Astronautics Inc. All rights reserved.

INTRODUCTION

The Glow Discharge at Atmospheric Pressure (GDAP) is generated within a gap between two electrodes, at least one of which is insulated¹⁻³. It is generally driven by an AC voltage source capable of delivering few Kilovolts at a frequency of few Kilohertz. Most recently Alexeff & Laroussi were able to generate a similar large volume discharge at atmospheric pressure using a 60 Hz or a DC power source^{4,5}. Novel industrial applications of the GDAP such as the surface modification of polymers³, and the decontamination of media^{6,7} are attracting increased interest. To optimally tailor the plasma generated by the GDAP to a particular application the authors developed an analytical model of the discharge⁸. This model relates input parameters such as the amplitude and the frequency of the applied voltage to output parameters such as the discharge current and the electron number density. In this paper calculations of the current, total applied power, dissipated energy, number density, etc... are presented for the two modes of operation of the discharge.

MODEL

The model developed by the authors is based on the electrical characteristics of the discharge. In this model two non-linear differential equations which relate the applied voltage to the resulting current and electron number density are derived⁸. The production and loss mechanisms of the charged particles are taken into account. The two differential equations are given as follow

$$\frac{dn}{dt} = K_1 K_2 \frac{i^2}{n} - K_3 n^2 \quad (1)$$

$$\frac{di}{dt} = \frac{n}{K_1} \frac{dV}{dt} + K_1 K_2 \frac{i^3}{n^2} - \left(K_3 + \frac{1}{K_1 C_d}\right) ni \quad (2)$$

where i , V , and n are respectively the discharge current, the applied voltage, and the number density. C_d is the capacitance formed by the combination of the dielectrics and the sheath. K_1 , K_2 , and K_3 are constants respectively related to the collisionality and geometry of the plasma, the ionization rate, and the recombination rate. The constants K_1 , K_2 , and K_3 are calculated as follow

$$K_1 = \frac{m v d}{e^2 A} \quad (3)$$

Where v , m , e , d , and A are respectively the collision frequency, the electron mass, the electronic charge, the discharge gap distance, and the electrode area,

$$K_2 = \frac{\text{ionization efficiency}}{\text{ionization potential} \cdot \text{volume}} \quad (4)$$

and

$$K_3 = \text{constante} \cdot \sigma \cdot v \quad (5)$$

where σ is the bulk recombination cross-section, and v is the electrons mean velocity.

RESULTS AND DISCUSSION

The results are obtained for two insulated electrodes 3 cm apart, with an area of $7.85 \cdot 10^{-3} \text{ m}^2$, helium gas, and a sinusoidal applied voltage. Two frequencies, 15.6 kHz and 35.7 kHz, representing two operational modes of the discharge, are selected. The electron-neutral collision frequency is 10^{12} Hz. The initial conditions are $i(0) = 1 \mu\text{A}$, and $n(0) = 10^{10} \text{ m}^{-3}$. The magnitude of the applied voltage is adjusted so as to obtain comparable number densities in both operational modes ($f = 15.6 \text{ kHz}$, and $f = 35.7 \text{ kHz}$). For the case of $f = 15.6 \text{ kHz}$ the peak voltage is 6 kV, and for the case of $f = 35.7 \text{ kHz}$ the peak voltage is 3.5 kV.

Fig. 1a and Fig. 1b show that the discharge current has two different waveform shapes. For $f = 15.6 \text{ kHz}$ the current has the form of a wide pulse each half cycle. This is the well known mode observed by Kanazawa et al¹. For $f = 35.7 \text{ kHz}$ the current looks more like a distorted sinusoid, phase shifted with respect to the applied voltage. Fig. 2a and Fig. 2b show the number density. For both cases the number densities are comparable with stronger oscillations in the lower frequency case. Fig. 3a and Fig. 3b show the applied power. The average power in the higher frequency case is about half that of the lower frequency case. This is an interesting result since for both cases the number densities are equivalent. In the higher frequency mode a lower input power is therefore capable to generate a discharge as dense and more stable (lower oscillations of the number density) than

the low frequency mode. Fig. 4a and Fig. 4b are Current versus Voltage plots. The two modes of operation of the discharge are more apparent in these plots. For $f = 15.6$ kHz the i, V curve is a distorted parallelogram, while for $f = 35.7$ kHz the i, V curve is more like an ellipsoid. Fig 5a and Fig. 5b show the energy dissipated in the discharge during a 150 μ s period. The lower frequency mode dissipates about twice as much energy as the higher frequency mode. Fig. 6a and Fig. 6b show the accumulated charge on the dielectric during a time period of 150 μ s. Although the average value of the charge is equivalent in both cases, the oscillations are much more pronounced in the lower frequency mode. Fig. 7a and Fig. 7b show the resistance of the plasma layer for both modes. The average value is about 100 k Ω in both cases.

CONCLUSIONS

Two distinct modes of operations of the Glow Discharge at Atmospheric Pressure have been outlined: a "Low Frequency" mode and a "High Frequency" mode. Less applied power to generate and sustain a stable discharge with a certain number density is required in the higher frequency mode. The presented model also allows the calculation and time evolution of key parameters such as the electron number density, dissipated energy, the resistance of the discharge, the charge accumulation on the dielectrics etc...

REFERENCES

1. S. Kanazawa, M. Kogoma, T. Moriwaki, and S. Okazaki, " Stable Glow Plasma at Atmospheric Pressure", *J. Phys. D.: Appl. Phys.*, **21**, 839, (1988).
2. J. R. Roth, M. Laroussi, and C. Liu, " Experimental Generation of a Steady-State Glow Discharge at Atmospheric Pressure",

- In Proc. IEEE Int. Conf. Plasma Sci., 170, (1992).
3. F. Massines, C. Mayoux, R. Messaoudi, A. Rabehi, and P. Segur, " Experimental Study of an Atmospheric Pressure Glow Discharge: Application to Polymers Surface Treatment", In Proc. Int. Conf. Gas Disch. & Appl., 730, (1992).
4. I. Alexeff, M. Laroussi, W. Kang, and C. Malott, " Biological Applications of Non-Equilibrium Plasmas", In Proc. ElectroMed 99, 110, (1999).
5. I. Alexeff, M. Laroussi, W. Kang, and A. Alikafesh, " A Steady-State One Atmosphere Uniform DC Glow Discharge Plasma", In Proc. IEEE Int. Conf. Plasma Sci., (1999).
6. M. Laroussi, " Sterilization of Tools and Infectious Waste by Plasmas", *Bull. Amer. Phys. Soc. Div. Plasma Phys.*, **40**, 1685, (1995).
7. M. Laroussi, " Sterilization of Contaminated Matter with an Atmospheric Pressure Plasma", *IEEE Trans. Plasma Sci.*, **24**, 1191, (1996).
8. M. Laroussi and I. Alexeff, " Modes of Operation of the Glow Discharge at Atmospheric Pressure", In Proc. IEEE Int. conf. Plasma Sci., (1999).

ACKNOWLEDGEMENT

This work was supported in part by AFOSR contract AF49620-95-1-0277 in cooperation with DDR&E Air Plasma Rampart MURI Program.

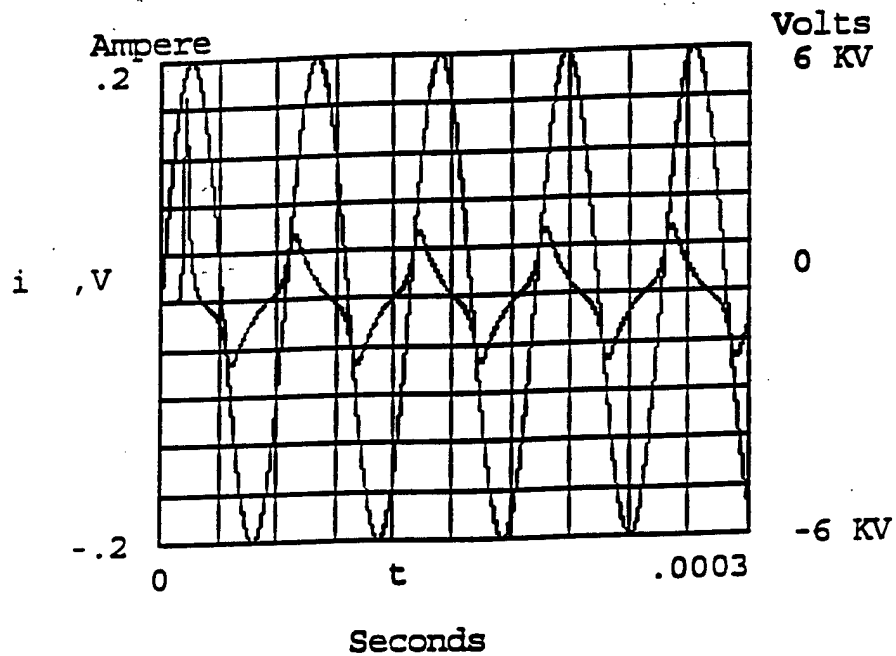

Fig. 1a Applied voltage, and discharge current Vs. time for $f = 15.6$ kHz.

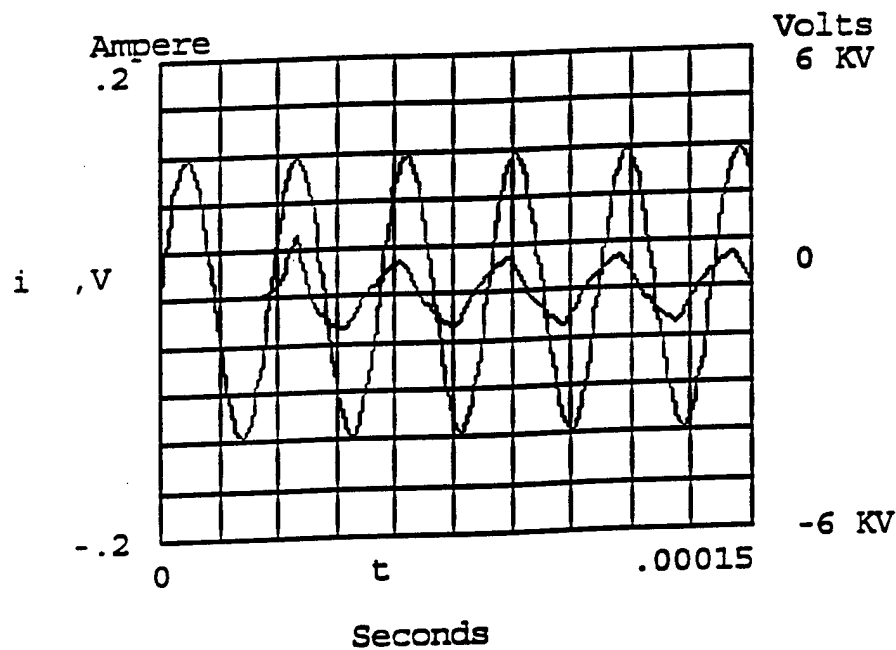

Fig. 1b Applied voltage, and discharge current Vs. time for $f = 35.7$ kHz.

American Institute of Aeronautics and Astronautics

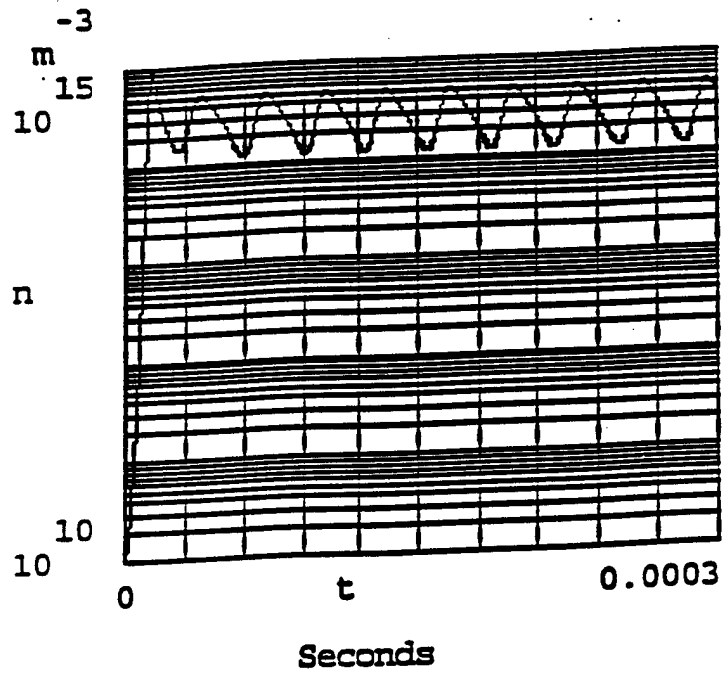

Fig. 2a Number density Vs. time for $f = 15.6$ kHz.

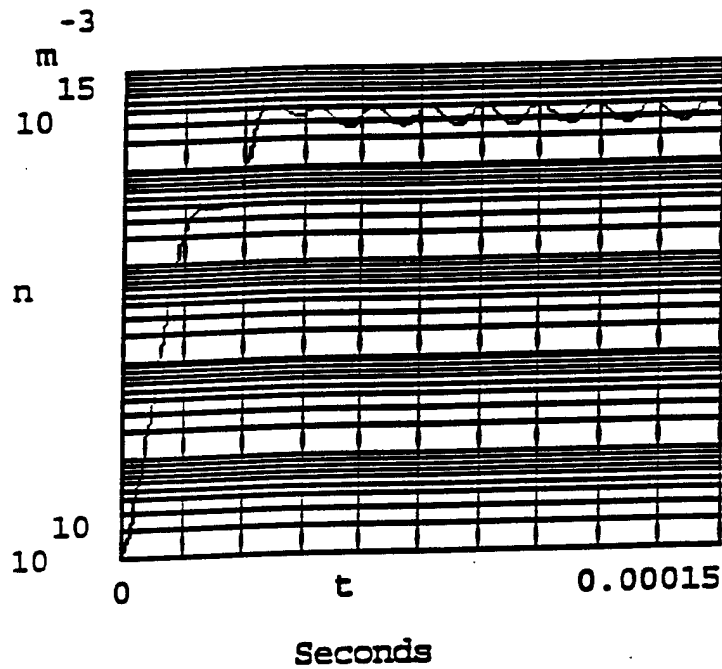

Fig. 2b Number density Vs. time for $f = 35.7$ kHz.

American Institute of Aeronautics and Astronautics

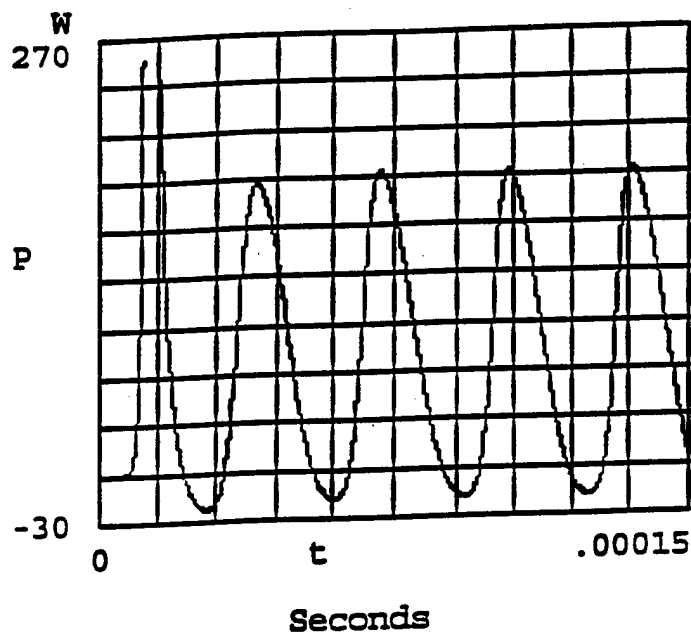

Fig. 3a Applied power Vs. time for $f = 15.6$ kHz.

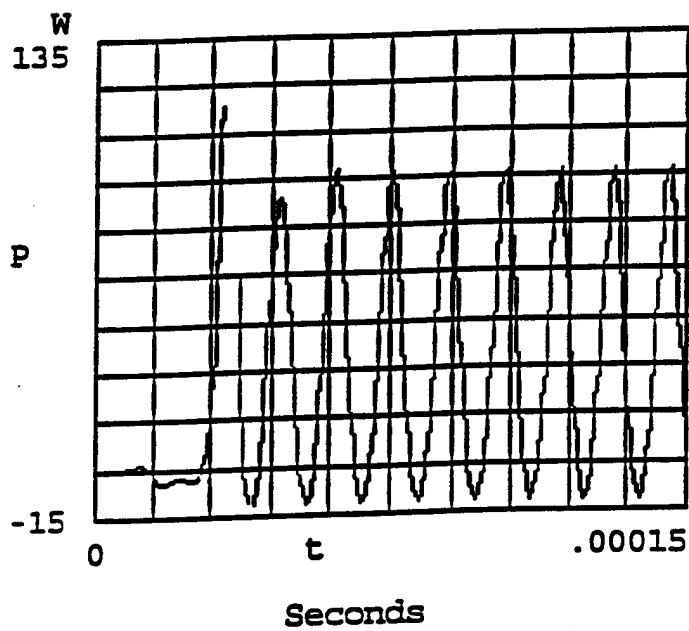

Fig. 3b Applied power Vs. time for $f = 35.7$ kHz.

American Institute of Aeronautics and Astronautics

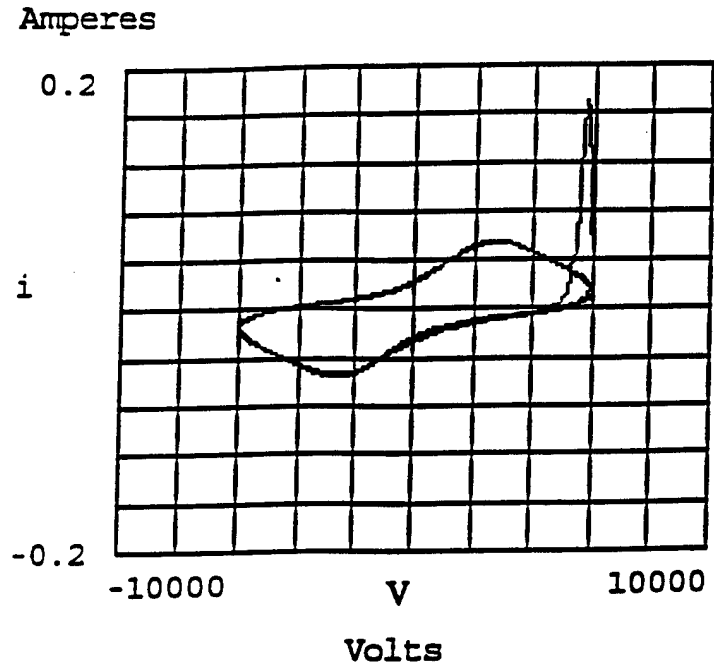

Fig. 4a Current-Voltage plot for $f = 15.6$ kHz.

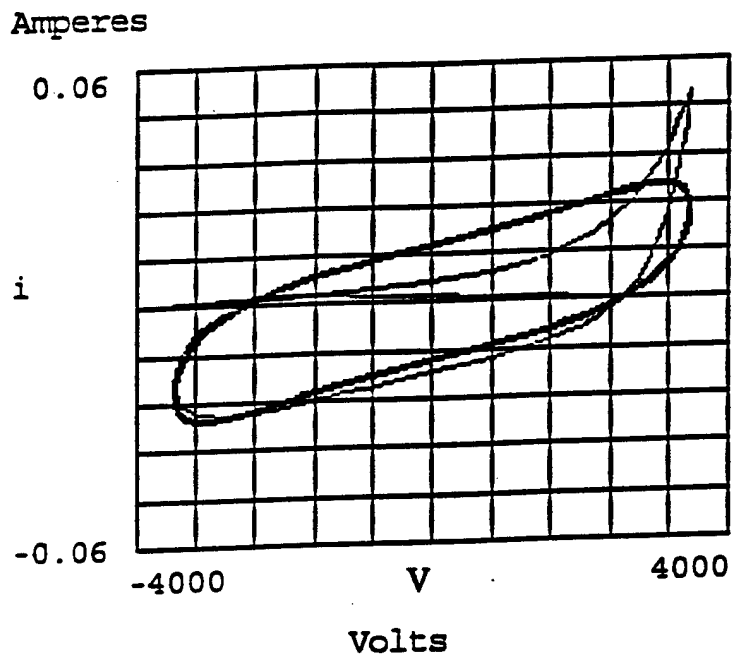

Fig. 4b Current-Voltage plot for $f = 35.7$ kHz.

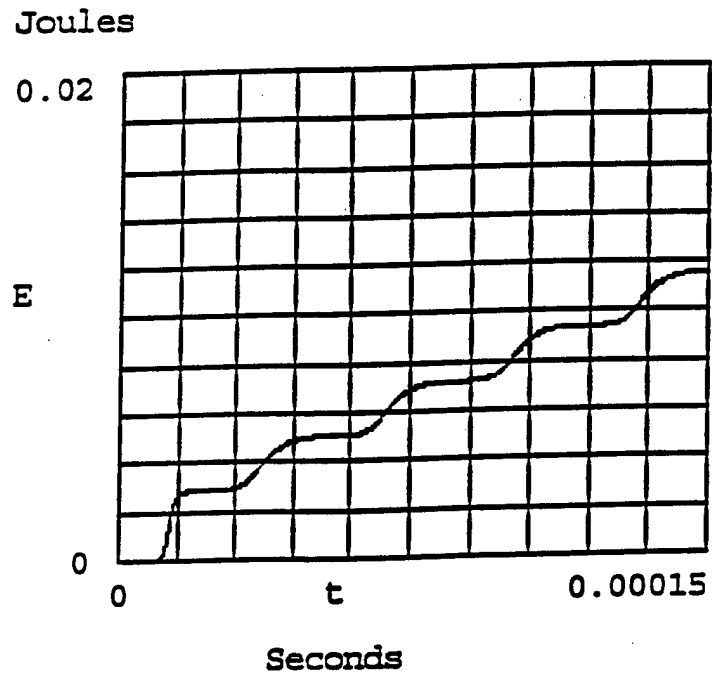

Fig. 5a Dissipated energy Vs. time for $f = 15.6$ kHz.

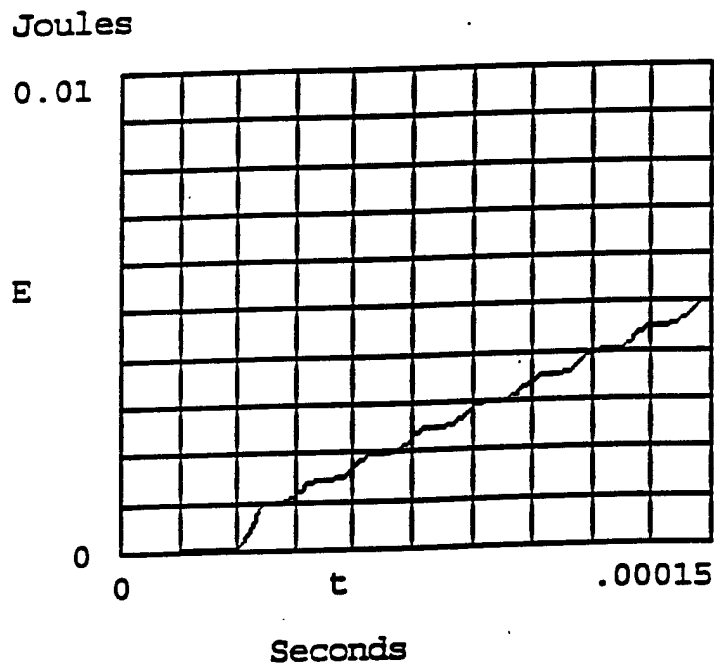

Fig. 5b Dissipated energy Vs. time for $f = 35.7$ kHz.

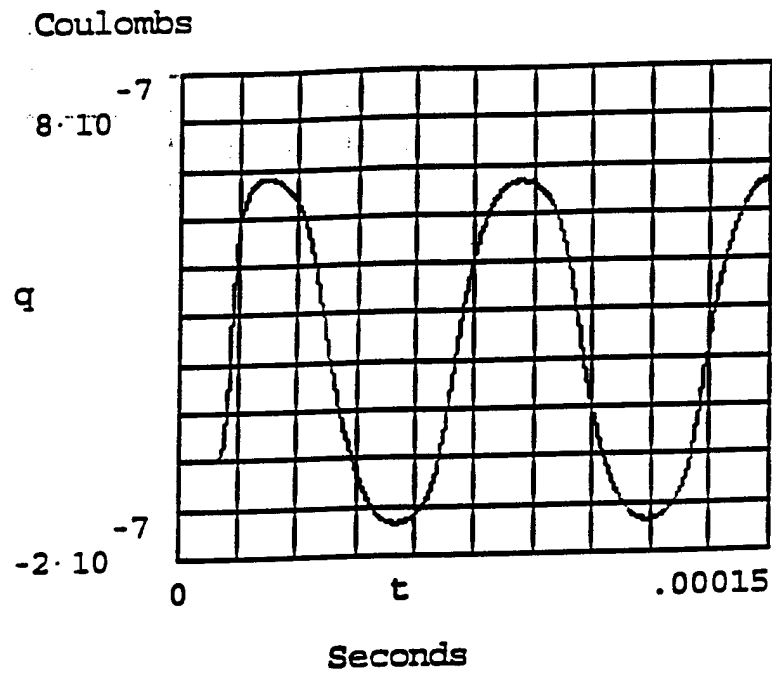

Fig. 6a Accumulated charge Vs. time for $f = 15.6$ kHz.

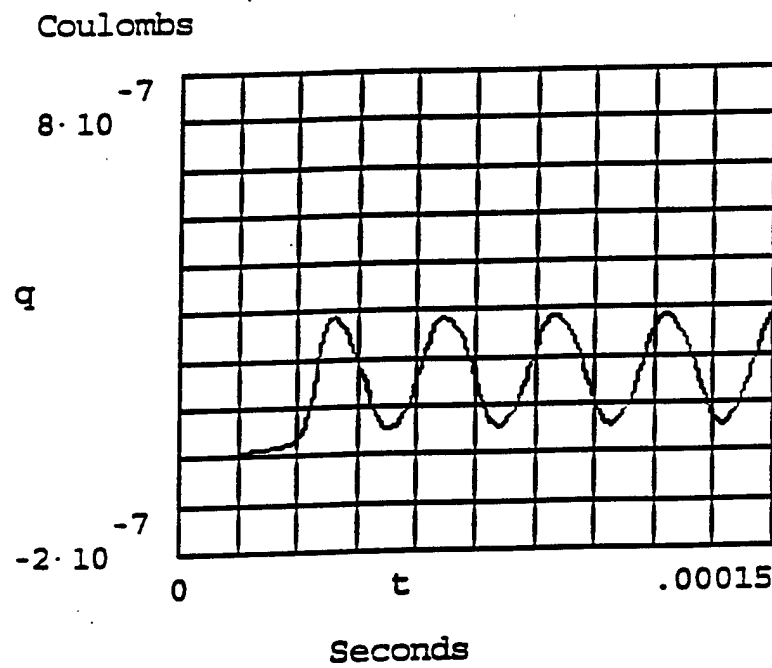

Fig. 6b Accumulated charge Vs. time for $f = 35.7$ kHz.

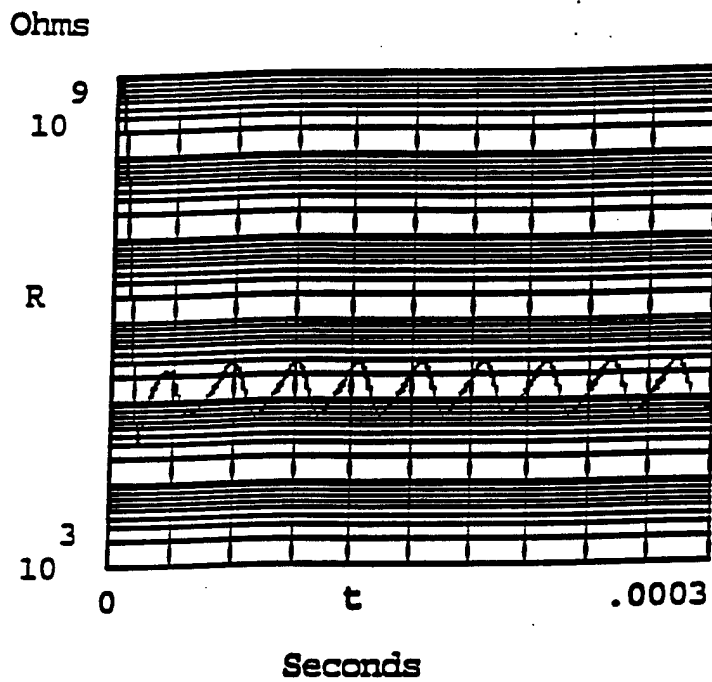

Fig. 7a Discharge resistance Vs. time for $f = 15.6$ kHz.

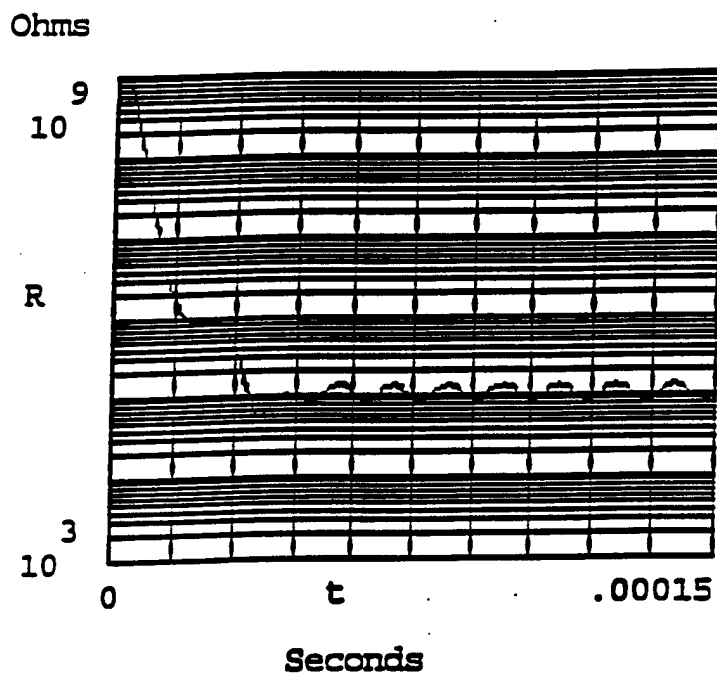

Fig. 7b Discharge resistance Vs. time for $f = 35.7$ kHz.

American Institute of Aeronautics and Astronautics

M. Laroussi

ICOPS₂₀₀₀



IEEE Conference Record – Abstracts

**The 27th IEEE International Conference
on Plasma Science**

**New Orleans, Louisiana, USA
June 4 – 7, 2000**



Sponsored by:

The Plasma Science and Applications Committee
of the IEEE Nuclear and Plasma Sciences Society

Co-Sponsors:

- Mississippi State University
Department of Electrical and Computer Engineering
Division of Continuing Education
- Air Force Office of Scientific Research

**ON THE USE OF THE RESISTIVE BARRIER
DISCHARGE TO KILL BACTERIA: RECENT RESULTS***

John P. Richardson¹, Francis F. Dyer¹, Fred C. Dobbs¹
Igor Alexeff², and Mounir Laroussi¹

1. Old Dominion University, Norfolk, VA
2. The University of Tennessee, Knoxville, TN

ABSTRACT

Large volume, atmospheric pressure, low-temperature plasmas have been shown to be effective biological and chemical decontamination devices [1]-[3]. However, most of the discharges use RF power sources capable of generating high voltages at relatively high frequencies. Such sources are not only expensive, but they radiate power which can potentially affect sensitive electronics located in their surroundings. In order to solve these cost and technical drawbacks, Alexeff, Laroussi, and co-workers [4] introduced the Resistive Barrier Discharge (RBD) which uses either DC or quasi-DC (60 Hz) sources. With an input power less than 1 kW, and helium as a carrier gas, the RBD is capable of generating a few liters of low-temperature plasma, at atmospheric pressure.

Recent work by Laroussi, Dobbs, and co-workers has demonstrated that the plasma generated by the RBD decreases viability (estimated by cultural techniques) of bacteria. In this paper, in addition to reporting on the germicidal potential of the RBD, an attempt to identify some of its biochemical impact on bacterial cells will be made.

[1] M. Laroussi "Sterilization of Contaminated Matter with an Atmospheric Pressure Plasma", *IEEE Trans. Plasma Sci.*, Vol.24, No.3, pp. 1188-1191, 1996.

[2] J. G. Birmingham et al. "Corona Discharge Plasma Reactor for Decontamination", in *Proc. IEEE Int. Conf. Plasma Sci.*, p.183, 1998.

[3] H. W. Hermann, I. Henins, J. Park, and G. S. Selwyn, "Decontamination of Chemical and Biological Warfare (CBW) Agents Using an Atmospheric Pressure Plasma Jet", *Phys. Plasmas*, Vol. 6, No. 5, pp.2284-2289, 1999.

[4] I. Alexeff, M. Laroussi, W. Kang, and A. Alikafesh, "A Steady-State One Atmosphere Uniform DC Glow Discharge Plasma", in *Proc. IEEE Int. Conf. Plasma Sci.*, p. 208, 1999.

* Work supported in part by AFOSR contract F49620-97-1-0472

**The D.C Atmospheric Barrier Plasma Discharge –
Recent Results**

Igor Alexeff, Carlton Garland, Weng Lock Kang,
The University of Tennessee, Mounir Laroussi,
Old Dominion University

We have been generating intense, steady - state, D. C. discharges in air and other gases, notably helium. Previous results were presented at ICOPS in June, '99. The discharge appears to fill the chamber volume uniformly, without sparks or striations. The basic improvement that prevents the discharge from contracting into a spark or an arc is an unglazed ceramic plate that has been moistened with water to make it into a semiconductor (patent pending). With this improvement, we have put up to 300 Watts of steady - state D. C. power (30 KV. at 10 mA. - the power supply limit.) into about a liter of helium plasma at atmospheric pressure. The discharge also works well in atmospheric pressure air, although the gap between the discharge electrodes must be reduced. The system has run for over 30 minutes with no problems. The system also works well on 60 Hz. A. C. from a simple transformer, such as that used for neon signs.

For diagnostics, we have developed an apparently new diagnostic probe, the **Diffusion Probe**, that is useful in the D. C. or low - frequency A. C. regimes where ion and electron motion is diffusive, rather than ballistic, as is the case for the Langmuir Probe. With this probe, we have measured plasma ion densities of over 10 exp. 12 per cc. A brief, incomplete, overview of the probe operation is as follows: The probe is composed of two small parallel plates, placed perpendicular to the ion flow. First, the open - circuit voltage is measured between the two probes, to measure the electric field in the partially ionized gas. Second, the short - circuit current is measured to obtain the ion drift current in the gas. Knowing the ion mobility for the gas in question, we can solve for the ion density.

One recent, surprising result is that although the device operates in the steady - state and appears to the eye to be a quiescent, D. C. discharge, it is extremely active in the R. F. range. We have used both a photomultiplier and a high - speed photodiode for optical studies, and a Tektronix current probe on the feed from the power supply. We find two surprising results. First: the plasma light and discharge current are pulsed, not steady - state. The pulses are narrow, with a repetition rate of about 10 kHz. Second; the plasma is also oscillating at a frequency about 5 times higher. The mechanism of this unusual behavior is at present not understood.

**On the Use of the Resistive Barrier Discharge to Kill Bacteria:
Recent Results***

**J. Paul Richardson¹, Francis F. Dyer¹, Fred C. Dobbs¹, Igor Alexeff², and
M. Laroussi¹**

- 1. Old Dominion University**
- 2. The University of Tennessee**

**IEEE Int. Conf. Plasma Science
New Orleans, LA, June 4-7, 2000**

*** Work supported by AFOSR AASERT contract F49620-97-1-0472**

Abstract

Glow discharges at atmospheric pressure [1] and Corona discharges [2], [3] have been shown to be effective means of biological decontamination. R.F. driven discharges such as the Glow Discharge at Atmospheric Pressure [4] have the advantage of producing large volume plasmas, but require expensive and bulky power supplies capable of producing several kilovolts at frequencies of few kilohertz (audio frequencies). Recently, Alexeff & Laroussi solved this problem by producing a large volume glow discharge at atmospheric pressure using a DC or 60 Hz power source [5]. The use of a DC or 60 Hz supply makes this discharge more practical and much less expensive than the R.F. driven discharge.

The use of R.F. and DC driven discharges showed that a large population ($\sim 10^8$ per ml) of harmful microorganisms can be neutralized after a few minutes exposure to the plasma. The optimum exposure time is dependent on the type of microorganism, the medium supporting the microorganism, the plasma power density, and the gas mixture used in the discharge [6]. It is speculated that free radicals, such as OH, atomic oxygen, and radiation generated in the discharge interact with the cells of microorganisms and adversely alter their internal biochemistry. In this paper, in addition to reporting on the germicidal potential of non-thermal plasmas, an attempt to identify some of the morphological and biochemical impacts on bacterial cells will be made.

Introduction

The biological application of low temperature, atmospheric pressure plasmas has significant advantages over traditional sterilants and disinfectants.

- No chemical residues.**
- No damage to treated materials.**

In biological warfare zones, decontamination could be achieved without the use of sterilizing chemicals.

Hospital instruments could be sterilized and used repeatedly without chemical cleanup or damage to the instruments.

The first part of this poster presents the efficacy of plasma to inactivate spores and vegetative cells of *Bacillus subtilis* and the cells of *Escherichia coli*.

The second component of this poster delves into the effects of plasma on biochemical pathways of *Escherichia coli*.

Methods for killing experiments

Purified spores (*B. subtilis*)

Purified spores of *Bacillus subtilis* 6051 [7] were diluted and filtered onto cellulose nitrate filters. (See red text)

Filters were treated with atmospheric pressure plasma produced with two different gas mixtures.

- Helium only
- 97%-Helium/3%-Oxygen

Filters were placed onto nutrient agar and incubated for 18 hours.

Colony forming units (CFUs) were enumerated. vegetative cells (*B. subtilis*)

Suspensions of *B. subtilis* vegetative cells were prepared and samples of 1mL were placed onto open Petri dishes.

The Petri dishes were treated with plasma.

– 16.70 kV

– 3%Oxygen:97%Helium mixture

Dilutions of the cells were then plated, incubated and CFUs were enumerated.

vegetative cells (*E. coli*)

Escherichia coli 25922 cells were diluted and then plated onto nutrient agar.

The nutrient agar plates containing the cells were then placed into the plasma reactor and treated.

These plates were then incubated at 37°C for 18 hours.

CFUs were then enumerated.

Comparison of 32:1 Helium:Oxygen and Helium Only

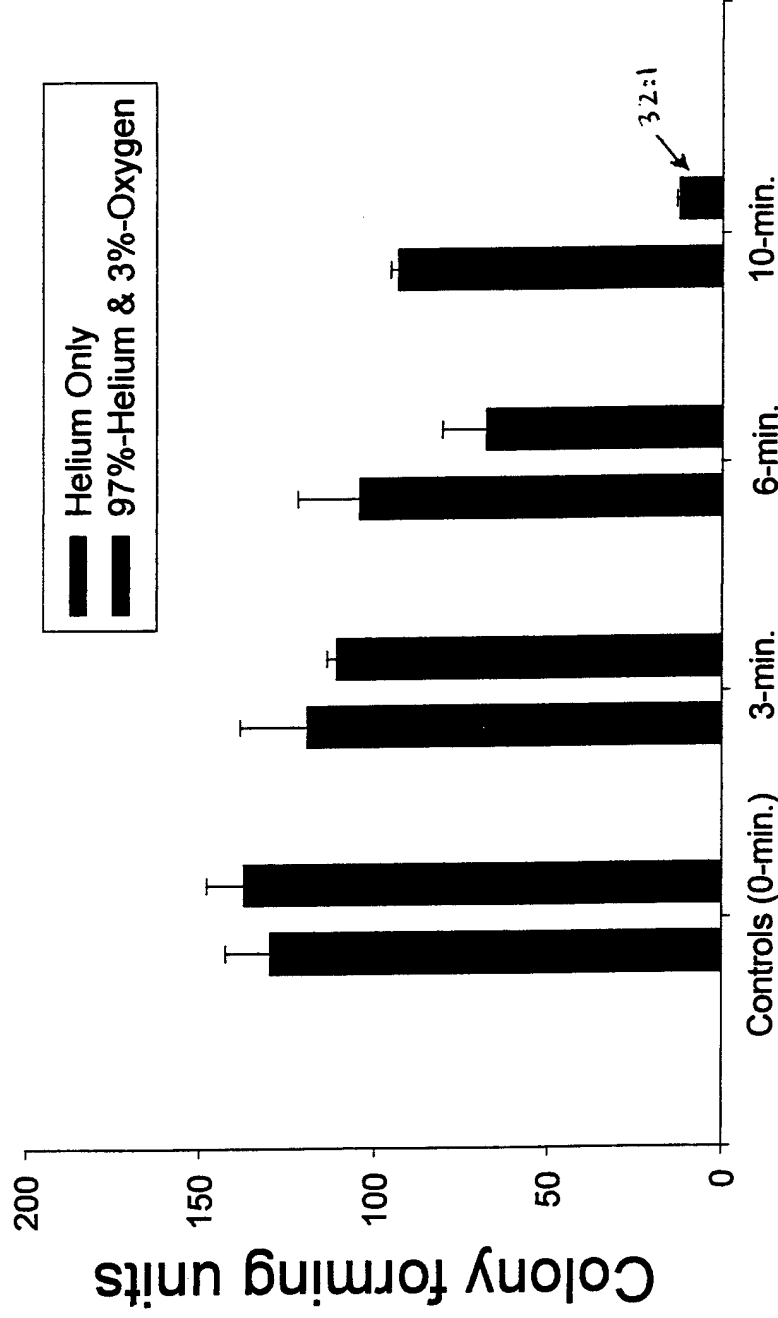

Plasma treatment times

Mean (± 1 s.d.) colony forming units (n=3) following treatment of *Bacillus subtilis* spores with plasma. Voltage=13.22kV for the helium only and 19.47kV for the 32:1 helium:oxygen mixture.

Cells/ml Versus Treatment Time for 3 E. coli Samples

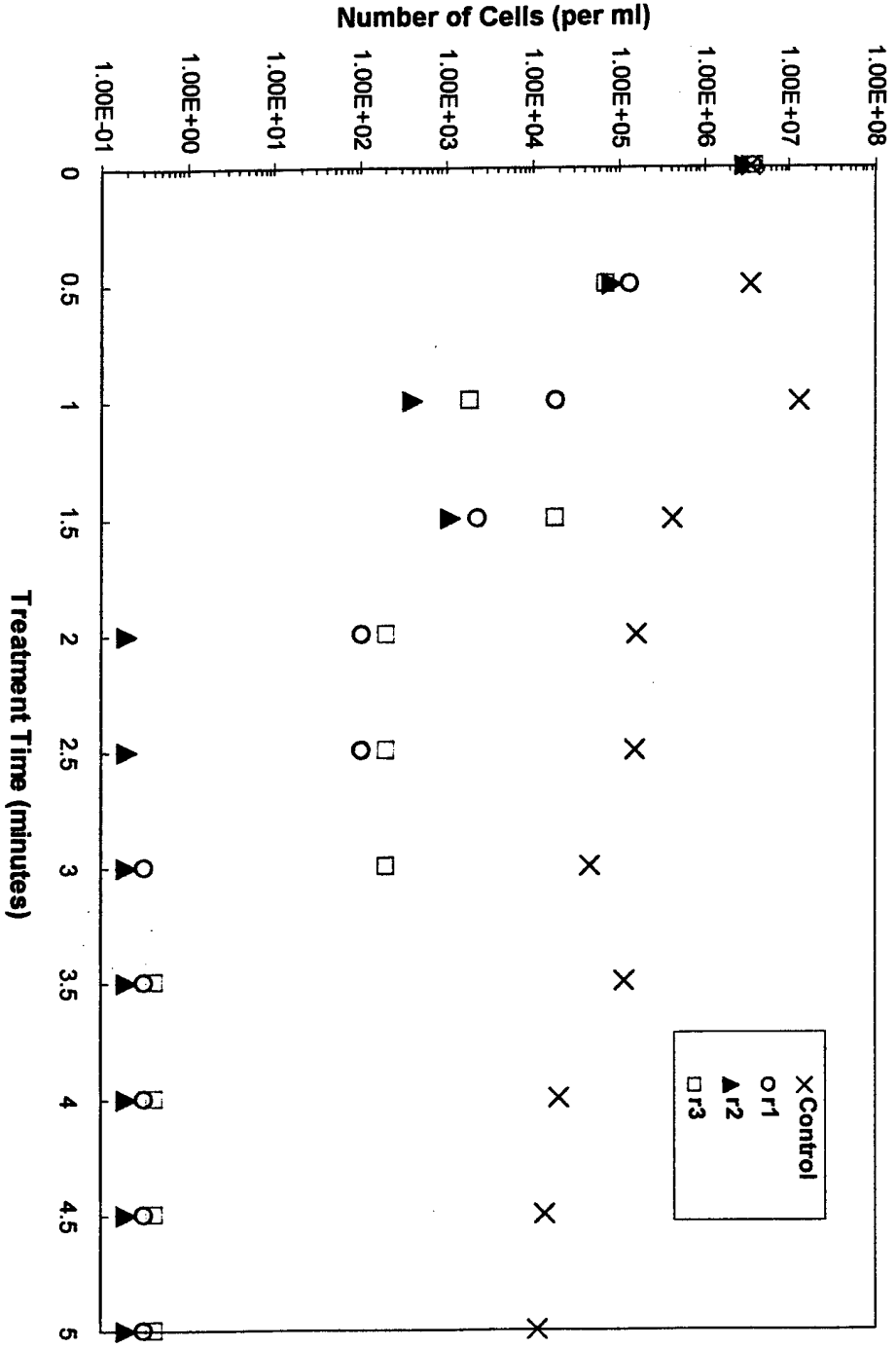

Kill data for vegetative *B. subtilis*

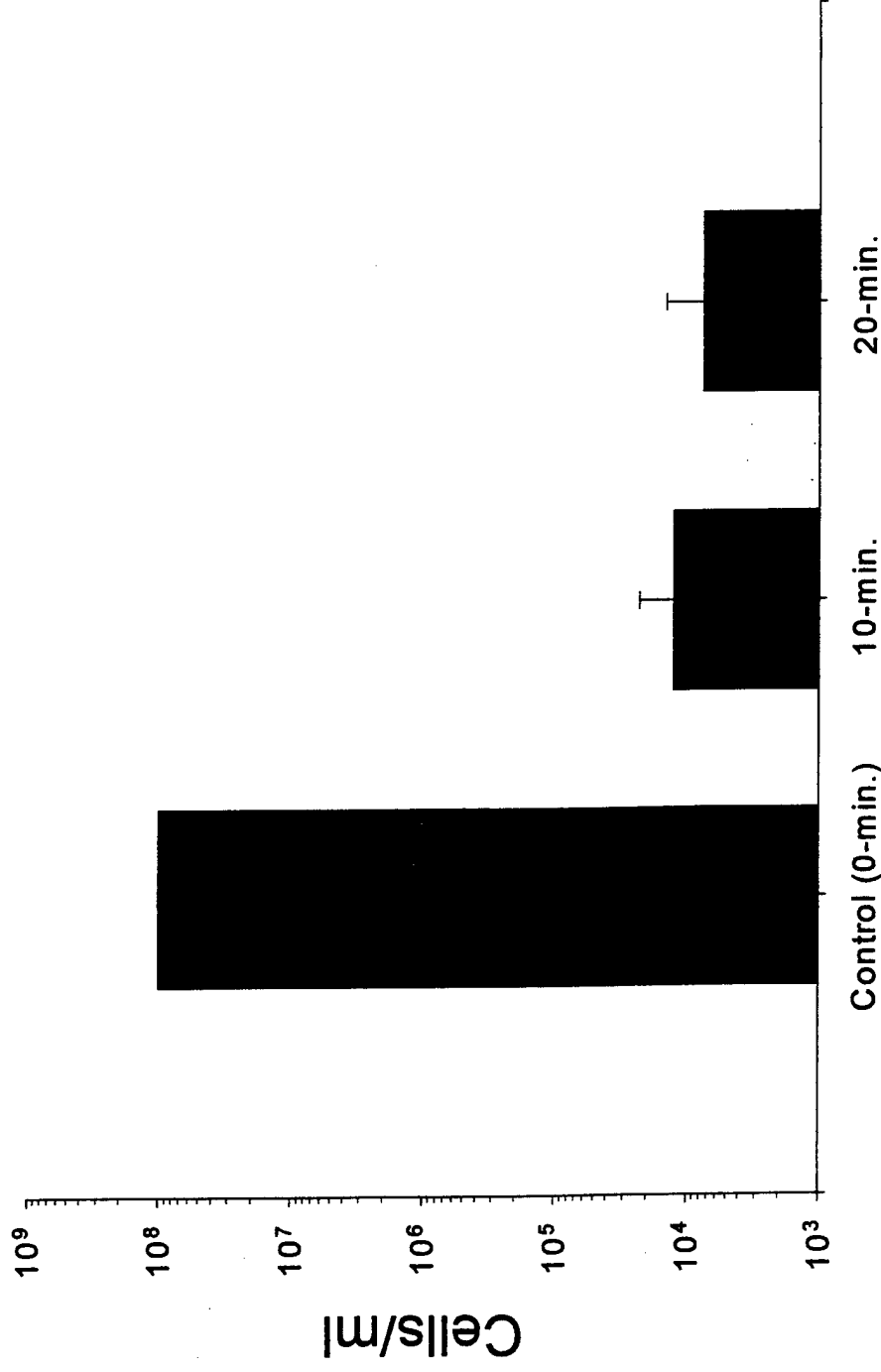

Plasma treatment times

Mean (± 1 s.d.) colony forming units ($n=2$) following the treatment of *Bacillus subtilis* vegetative cells with plasma. Voltage=16.7kV for a 32:1 helium:oxygen gas mixture.

a

b

Plasma treated (a) and untreated (b) vegetative cells of *B. subtilis*. Magnification=1600X (a) and 1250X (b); differential interference contrast microscopy. There were no gross morphological differences between treated and untreated cells.

Methods for sublethal effects experiments (carbon substrates)

Utilization of 95 different carbon substrates by *Escherichia coli* was evaluated.

E. coli was treated with a sublethal dose of atmospheric pressure plasma.

Plasma treated cells were incubated for 4 days in 95 different carbon substrates.

Results of carbon substrate utilization experiments

When all 95 substrates were considered together, their utilization by *E. coli* was unaffected by treatment with plasma.

– The average well color development was not statistically different between controls and plasma treated samples.

However, plasma treatment enhanced utilization of some carbon substrates.

Conversely, plasma treatment depressed utilization of other carbon substrates.

b

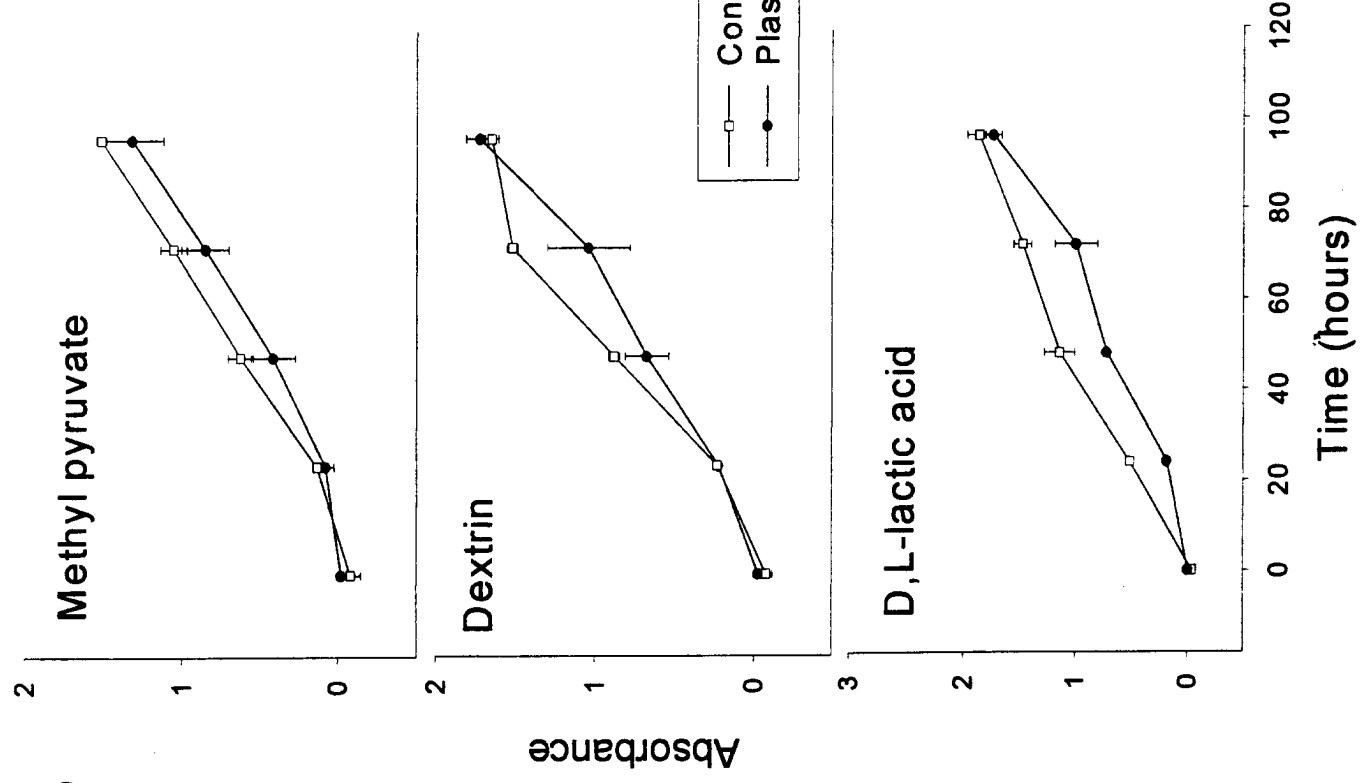
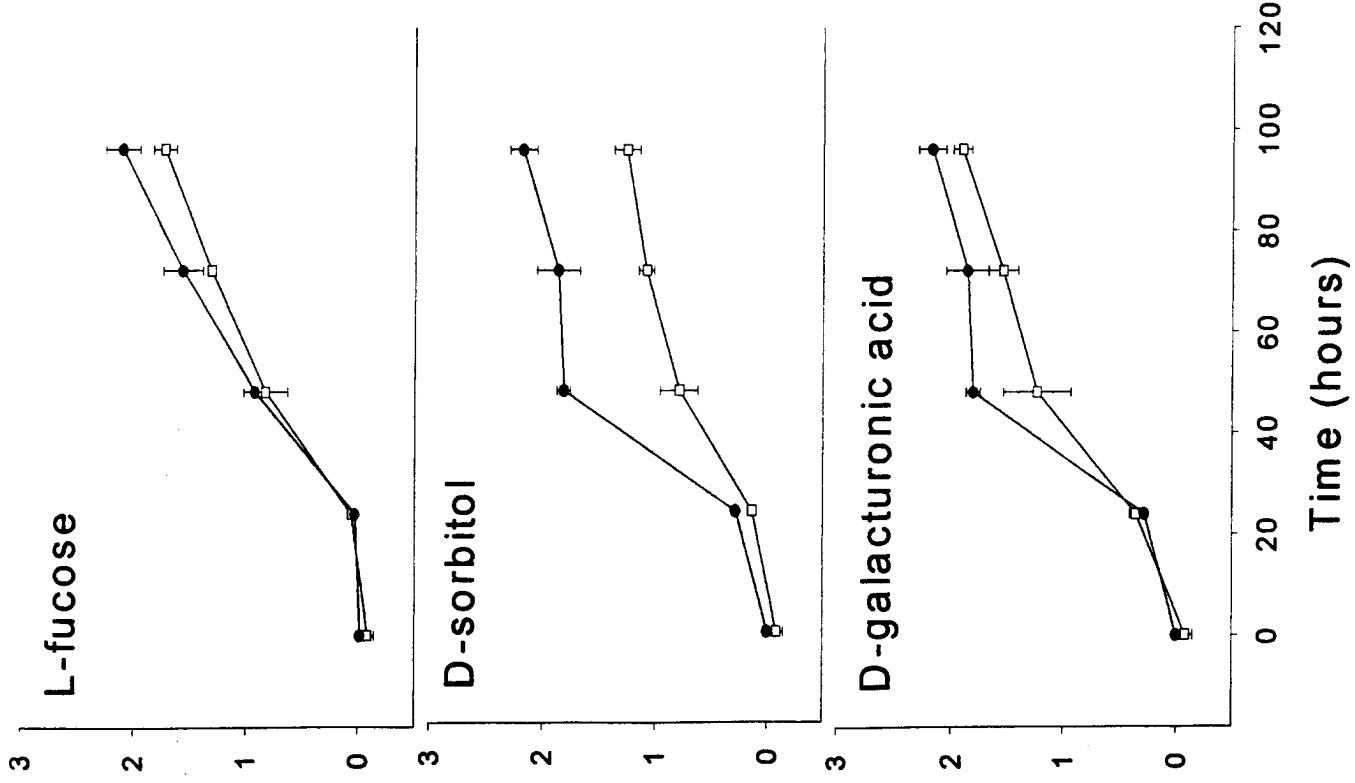

(a) Increased and (b) Decreased utilization of substrates by *E. coli* after exposure to plasma.

Conclusions regarding sublethal effects

When carbon substrate utilization is repressed, then the plasma may be degrading or inhibiting enzymes.

When utilization of certain substrates is enhanced, then the plasma may increase enzyme activities.

Future work

Killing experiments will be repeated to determine the optimal gas mixture.

More experiments examining the biochemical effect(s) of plasma on bacteria will be performed.

Bacteria will be examined using electron microscopy to determine any ultrastructural changes that might be induced by treatment with plasma.

References

- [1] M. Laroussi " Sterilization of Contaminated Matter with an Atmospheric Pressure Plasma", IEEE Trans. Plasma Sci., Vol.24, No.3, pp. 1188-1191, 1996.
- [2] E. Garate et al. " Atmospheric Plasma Induced Sterilization and Chemical Neutralization", in Proc. IEEE Int. Conf. Plasma Sci., p. 183, 1998.
- [3] J. G. Birmingham et al. "Corona Discharge Plasma Reactor for Decontamination", in Proc. IEEE Int. Conf. Plasma Sci., p.183, 1998.
- [4] S. Kanazawa et al. " Stable Glow Plasma at Atmospheric Pressure", J. Phys. D: Appl. Phys., 21, pp.838-840, 1988.
- [5] I. Alexeff, M. Laroussi et al., " A Steady-State One Atmosphere Uniform DC Glow Discharge Plasma", In Proc. IEEE Int. Conf. Plasma Sci., p. 208, 1999.

[6] M. Laroussi et al. "Images of Biological Samples Undergoing Sterilization by a Glow Discharge at Atmospheric Pressure", IEEE Trans. Plasma Sci., Vol.27, No.1, pp.34-35, 1999.

[7] N. Munakata et al. "Genetically Controlled Removal of Spore Photoproduct from Deoxyribonucleic Acid of Ultraviolet-Irradiated *Bacillus subtilis* Spores" J. Bacteriol., Vol. 111, No. 1, pp. 192-198, 1972.

[8] M. T. Madigan et al. "Brock Biology of Microorganisms", 8th Edition, Prentice Hall Inc., Upper Saddle River, New Jersey, pp. 94-100, 1996.