

January 18, 2000

**ADVANCED DISTRIBUTED
SIMULATION TECHNOLOGY II**

(ADST II)

***SYNTHETIC THEATER OF WAR-
ARCHITECTURE (STOW-A)***

FINAL REPORT

CDRL AB01

DO #0117

***160TH SPECIAL OPERATIONS AVIATION REGIMENT
(AIRBORNE) TRAINING EXERCISE II***



For:
United States Army
Simulation, Training, and Instrumentation Command
12350 Research Parkway
Orlando, Florida 32826-3224
Attn: AMSTI-ED

By:

Science Applications International Corporation
12479 Research Parkway
Orlando, FL 32826-3248



Lockheed Martin
Information Systems Company
12506 Lake Underhill Road
Orlando, FL 32825

LOCKHEED MARTIN

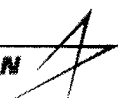

20000911 075

Approved for public release; distribution is unlimited.
UNCLASSIFIED

REPORT DOCUMENTATION PAGE

Form Approved
OMB No. 074-0188

Public reporting burden for this collection of information is estimated to average 1 hour per response, including the time for reviewing instructions, searching existing data sources, gathering and maintaining the data needed, and completing and reviewing this collection of information. Send comments regarding this burden estimate or any other aspect of this collection of information, including suggestions for reducing this burden to Washington Headquarters Services, Directorate for Information Operations and Reports, 1215 Jefferson Davis Highway, Suite 1204, Arlington, VA 22202-4302, and to the Office of Management and Budget, Paperwork Reduction Project (0704-0188), Washington, DC 20503

1. AGENCY USE ONLY (Leave blank)		2. REPORT DATE 18 JAN 2000	3. REPORT TYPE AND DATES COVERED FINAL	
4. TITLE AND SUBTITLE Advanced Distributed Simulation Technology II (ADST-II) Synthetic Theater of War-Architecture Final Report			5. FUNDING NUMBERS N61339-96-D-0002	
6. AUTHOR(S)				
7. PERFORMING ORGANIZATION NAME(S) AND ADDRESS(ES) Lockheed Martin Information Systems ADST-II P.O. Box 780217 Orlando FL 32878-0217			8. PERFORMING ORGANIZATION REPORT NUMBER ADST-II-CDRL-STOWA99-9900318A	
9. SPONSORING / MONITORING AGENCY NAME(S) AND ADDRESS(ES) NAWCTSD/STRICOM 12350 Research Parkway Orlando, FL 32328-3224			10. SPONSORING / MONITORING AGENCY REPORT NUMBER CDRL AB01	
11. SUPPLEMENTARY NOTES				
12a. DISTRIBUTION / AVAILABILITY STATEMENT Approved for Public release; distribution is unlimited				12b. DISTRIBUTION CODE
13. ABSTRACT (Maximum 200 Words) The Synthetic Theater of War-Architecture (STOW-A) 160 th Special Operations Aviation Regiment (SOAR) (Airborne) Training Exercise was conducted at the 160 th SOAR Training Facility at Fort Campbell, KY, from October 25 to October 29, 1999. The exercise was performed as Delivery Order (DO) #117 under the Advanced Distributed Simulation Technology II (ADST II) Contract administered by the U.S. Army Simulation, Training, and Instrumentation Command (STRICOM). The exercise was sponsored by STRICOM-STOW-A, USSOCOM, 160 th SOAR(A), NSC and Ft. Bragg. The exercise utilized a synthetic environment that employed virtual simulations to depict Special Operations Forces (SOF) air and ground missions executing two joint operation scenarios in realistic combat situations. The scenarios were executed on a real world classified terrain database. These scenarios were designed to produce effective operations orders and concepts, and induce the commanders and their planning staff to make tactical decisions that affected battle outcomes.				
14. SUBJECT TERMS STRICOM, ADST-II,			15. NUMBER OF PAGES 38	
			16. PRICE CODE	
17. SECURITY CLASSIFICATION OF REPORT UNCLASSIFIED	18. SECURITY CLASSIFICATION OF THIS PAGE UNCLASSIFIED	19. SECURITY CLASSIFICATION OF ABSTRACT UNCLASSIFIED		20. LIMITATION OF ABSTRACT

EXECUTIVE SUMMARY.....	vii
1. INTRODUCTION	1
1.1 Purpose.....	1
1.2 Delivery Order Overview.....	1
1.3 Exercise Overview.....	1
1.4 Technical Overview	1
2. Applicable Documents	2
2.1 Government.....	2
2.2 Non-Government	3
3. System Description	3
3.1 System Configuration and Layout	3
3.2 Description of System Components.....	6
3.2.1MH-60K CMS	6
3.2.2MH-47 CMS	6
3.2.3MC-130E BMC.....	7
3.2.4TOPScene	7
3.2.5OTB.....	7
3.2.6Builder.....	7
3.2.7Simulyzer	8
3.2.8SoundStorm	8
3.2.9ASTi Radios.....	9
3.2.10MetaVR.....	11
3.2.11SVS	11
3.2.12HLA/DIS Network.....	11
3.2.12.1 HLA SIM	13
3.2.12.2 HLA GATEWAY	13
3.2.12.3 DIS FILTER.....	13
3.2.12.4 FOM.....	14
3.2.12.5 RTI	14
3.2.12.6 VR-Link 3.4	14

3.3 Terrain Database and Scenario Development	14
4. Conduct of the Exercise	15
4.1 Troop Training	15
4.2 Exercise	15
5. Observations and Lessons Learned	15
6. Conclusion	19
7. Points of Contact	19
Acronym List	21
Appendix A- Additional Drawings	1
Appendix B- DIS Enumeration Table	1
Appendix C- Miscellaneous Technical Notes	4

List of Figures

FIGURE 1 EXERCISE NETWORK DIAGRAM WOLCOTT HALL.....	4
FIGURE 2 EXERCISE NETWORK DIAGRAM FRANK HALL.....	5
FIGURE 3 ASTi RADIO DIAGRAM FOR WOLCOTT HALL.....	10
FIGURE 4 ASTi RADIO DIAGRAM FOR FRANK HALL.....	11
FIGURE 5 NETWORK CONNECTIVIITY ARCHITECTURE	12
FIGURE 6 HURLBURT FIELD – FT. CAMPBELL HLA LONGHAUL ARCHITECTURE	13
FIGURE A-1 RADIO CONTROL UNIT (RCU) HAND HELD TERMINAL	A-1

List of Tables

TABLE 1 EXERCISE ASSETS..... 6

EXECUTIVE SUMMARY

The Synthetic Theater of War-Architecture (STOW-A) 160th Special Operations Aviation Regiment (SOAR) (Airborne) Training Exercise was conducted at the 160th SOAR Training Facility at Fort Campbell, KY, from October 25 to October 29, 1999. The exercise was performed as Delivery Order (DO) #117 under the Advanced Distributed Simulation Technology II (ADST II) Contract administered by the U.S. Army Simulation, Training, and Instrumentation Command (STRICOM). The exercise was sponsored by STRICOM-STOW-A, USSOCOM, 160th SOAR(A), NSC and Ft. Bragg. The exercise utilized a synthetic environment that employed virtual simulations to depict Special Operations Forces (SOF) air and ground missions executing two joint operation scenarios in realistic combat situations. The scenarios were executed on a real world classified terrain database. These scenarios were designed to produce effective operations orders and concepts, and induce the commanders and their planning staff to make tactical decisions that affected battle outcomes. The objectives of the effort were:

- 1) Integrate on-site assets, to include a live command and control helicopter via live/simulation radio links, an MH-60 and MH-47 CMS, OTB and 3D viewers along with Hurlburt Field's MC-130E WST to conduct a HLA training exercise.
- 2) Increase the battle staff synchronization of both the Air Mission Commander (AMC) and Ground Force Commander (GFC) through training and mission rehearsals at the 160th SOAR (A) facility.
- 3) To establish training system architecture that will provide the 160th SOAR with a simulation capability to refine and validate tactics for multi-aircraft all-weather operations.
- 4) Provide a leave behind capability for the 160th SOAR that enables them to conduct small scale training missions without extensive technical support

Development of the software modifications to the OneSAF TestBed (OTB) and the initial integration of software models were conducted at the ADST-II facility in Orlando and on site at the 160th SOAR. An initial network analysis and coordination meeting was held in June 1999, with four sub-system evaluations and initial integration efforts occurring at the 160th SOAR facility in June, July and August. Upon completion of these tests, a rehearsal phase began, with several rehearsals occurring in August, September, and October.

The exercise consisted of Alpha (Oct. 25-26) and Bravo (Oct. 28-29) missions, with different units being trained in each run. Days were allocated to developing the operations plans, staff planning and personnel training. The actual training exercise window per mission was three days. This three-day period included one day for mission planning, and two days for actual execution.

In accordance with the Government Statement of Work (SOW), this Final Report includes a description of the exercise, its conditions and conduct, and lessons learned. This report addresses the interconnectivity of simulation systems, manned simulators, and the integration of government and commercial furnished software models. This report does not include

discussion of data analysis nor conclusions as to achievement of the tactical or training objectives of the exercise.

1. INTRODUCTION

1.1 Purpose

The purpose of this final report is to document the ADST II effort that supported the Synthetic Theater of War-Architecture (STOW-A) 160th Special Operations Aviation Regiment (SOAR) (Airborne) Training Exercise. This report includes a full description of the exercise, its architectural design, its conditions, and lessons learned.

1.2 Delivery Order Overview

The STOW-A 160th SOAR (A) Training Exercise was executed as DO #0117 under the ADST II contract with STRICOM. This Unilateral Delivery Order (UDO) required ADST II to analyze the technical and experimental architecture of the exercise, configure and integrate the 160th SOAR assets for the exercise, and assist in data reduction, and train 160th staff in the proper usage of the leave-behind technology.

1.3 Exercise Overview.

To support AMC, GFC, and Battle Staff Synchronization for Training or Mission Rehearsal at the 160th SOAR, a series of exercises are to be conducted. Exercise Panther Leap, the second in a series of 160th SOAR(A) exercises built on the success of the Oct 98 exercise. Panther Leap integrated TOPScene for the visuals in the MH-47E CMS, it incorporated the OneSAF Testbed Baseline (OTB) semi-automated forces to augment the air and provide ground forces, it relied on High Level Architecture (HLA) multicast mode for simulation communication, it provided three-dimensional viewers (SVS and MetaVR) for ground operations, it stabilized the live radio to simulated radio link with simPhonic, and it used Air Force Special Operations (AFSOC) MC-130E Weapon System Trainer (WST).

1.4 Technical Overview

The technical approach to The STOW-A 160th SOAR (A) Training Exercise involved the analysis of the technical and experimental architecture of the exercise, development of software, and the configuration and integration of the 160th SOAR assets into the exercise configuration.

Software development was conducted at ADST-II facilities in Orlando, and then completed on-site at the 160th SOAR. Four Sub-system Evaluations (SSE) were conducted in June, July, and August of 1999 to allow for customer interface and evaluation. These SSE periods provided an opportunity for on-site corrections/modifications, which allowed for a "spiral development" methodology, with multiple "code, test, fix/change" iterations in order to meet the customer's requirements. Once the synthetic environment functional tests were completed, a rehearsal schedule was begun. The rehearsals began in late August and continued on an every other week basis until exercise week in October. This schedule enabled the 160th and Ranger elements to familiarize themselves with the capabilities of the

systems to be used in the exercise. The exercise Alpha and Bravo missions occurred in the week of Oct. 25 – 29, with different Air and Ranger units performing the planning and training for each run.

The general objectives of the SSE periods were:

1. Establish system high-level compatibility confirmation.
2. Establish simulation to simulation, live to simulation and simulation to live communications.
3. Establish acceptability confirmation by replicating the conditions of the training scenario.
4. Establish terrain database correlation between all elements
5. Establish DIS network reliability and issues
6. Establish HLA network reliability and issues
7. Establish DIS Enumeration confirmation
8. Establish a plan for site layout and site configuration.
9. Evaluate basic entity reactions.
10. Dry-run individual data collection procedures and operator training procedures.
11. Provide SoundStorm support for Ranger training.
12. Provide SVS support for Ranger training
13. Provide MetaVR support for Special Forces training
14. Establish OTB air/ground force usability

At the conclusion of each SSE an assessment was made on the current status of the program and the priorities established for future actions. Minutes were published after each SSE to effectively track action items and define responsibilities.

2. Applicable Documents

2.1 Government

- ADST II Work Statement for The Synthetic Theater of War-Architecture (STOW-A) 160th Special Operations Aviation Regiment (SOAR) (Airborne) Training Exercise, May 11, 1998, AMSTI-99-WO42

2.2 *Non-Government*

- Network Integration Plan, STOW-A 1999
- Application Gateway (AG) STOW-A 1.6.1 Release Software Version Description Document
- Cell Interface/Adapter Unit (CIAU) STOW-A 1.6.1 Release Software Version Description Document
- ModSAF STOW-A Release 1.6.1 Software Version Description Document
- OPSIN STOW-A 1.6.1 Release Software Version Description Document
- STRIPES STOW-A 1.6.1 Release Software Version Description Document

3. System Description

3.1 *System Configuration and Layout*

The 160th SOAR Training Facility contained and was configured with simulators, networks, Semi-automated Forces (SAF) capabilities, displays for monitoring the battlefield, and utilities to facilitate exercise automated data collection and reduction capabilities. The facility consisted of two separate buildings, Wolcott and Frank Hall. Wolcott Hall was designated as the training audience facility and housed the manned CMS simulators, Ranger and Special Forces OTB stations with SoundStorm, SVS and MetaVR stealths. Frank Hall was designated as exercise control and housed the OTB aviation and threat stations, OTB Logger, MetaVR stealth, and the Simulyzer data collection station. Frank Hall also provided the big screen views and video that was used for viewing the exercise and for AARs. Figures 1 and 2 depict the network diagrams of Wolcott Hall and Frank Hall.

160th SOAR STOW-A Exercise Network Diagram – Wolcott Hall

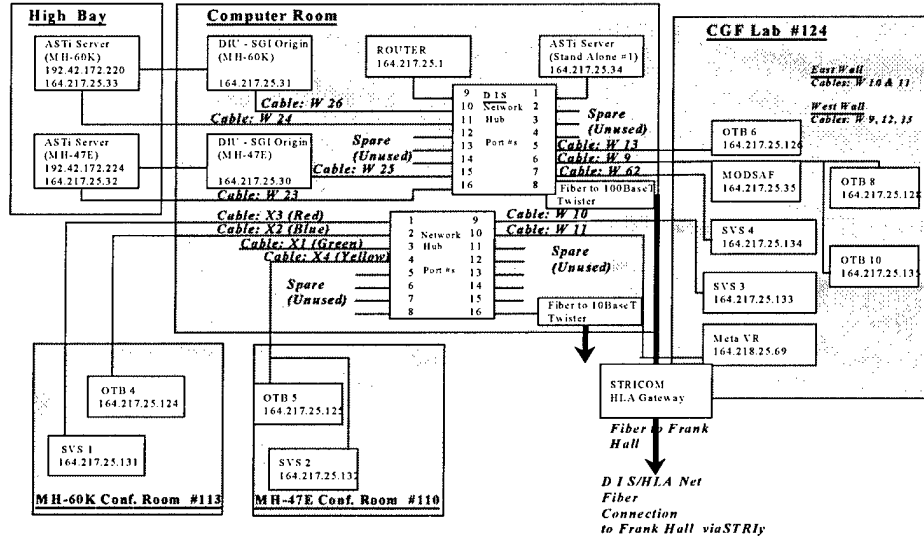

Figure 1 Exercise Network Diagram Wolcott Hall

160th SOAR STOW-A Exercise Network Diagram – Frank Hall

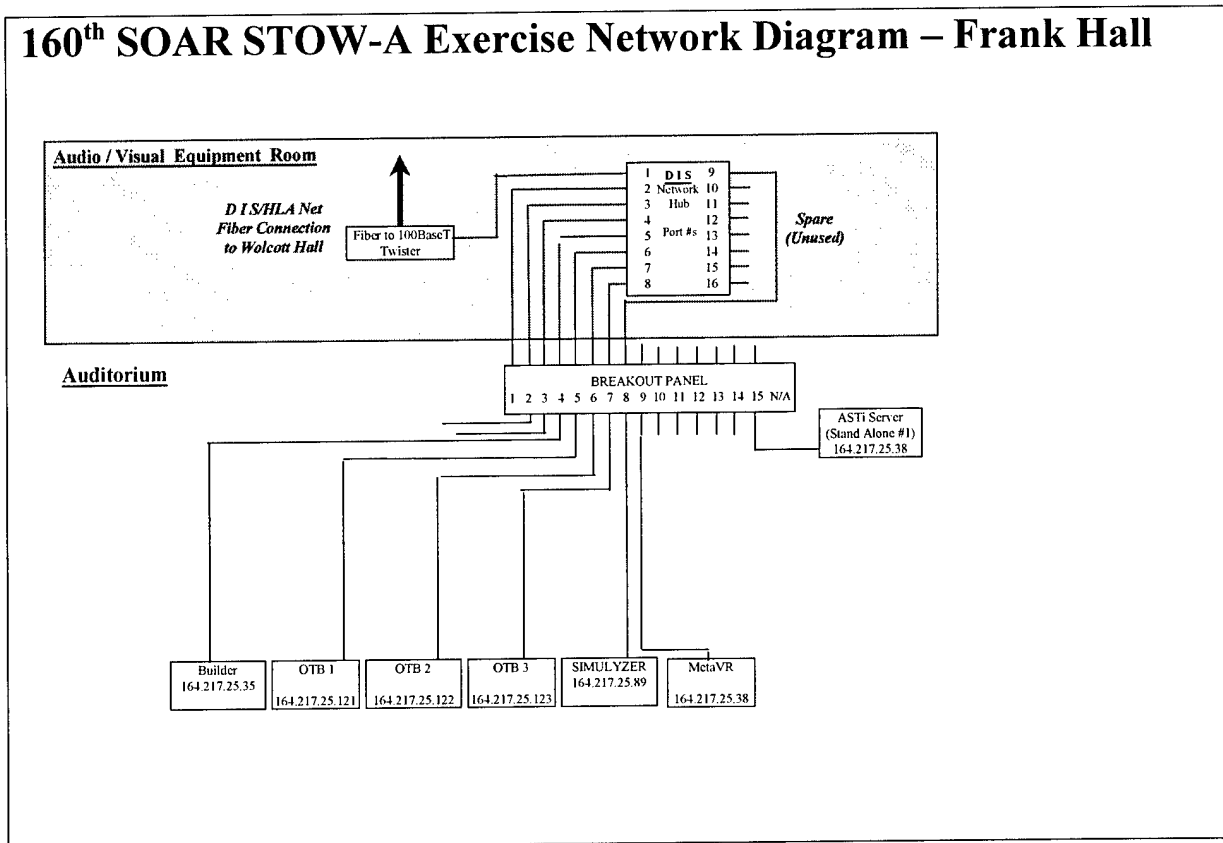

Figure 2 Exercise Network Diagram Frank Hall

The exercise was conducted using assets interconnected on Ethernet local area networks (LANs) via twisted pair cable and fiber optic links between buildings. Additionally, a secure long haul T1 network provided connectivity with the MC-130E BMC at Hurlburt Field. Simulation assets used Distributed Interactive Simulation (DIS) 2.04 protocol. Table 1 lists assets used at the 160th SOAR.

ASSET	PURPOSE	NETWORK PROTOCOL
Combat Mission Simulator MH-60	Manned MH-60 Simulator used for the flight lead for the exercise.	DIS 2.04
OTB	Semi-automated forces used to replicate air, ground, and threat components for the exercise	DIS 2.04
MetaVR	Exercise ground stealth view	DIS 2.04

SVS	Exercise ground stealth view	DIS 2.04
SoundStorm	Sound support for Rangers	DIS 2.04
ASTi Radio Simulator	Simulated Radio Communications	DIS 2.04
Symphonics	Simulation to live radio connection	DIS 2.04
Builder	Terrain Map of the battlefield for Exercise Control (simulated C2 display)	DIS 2.04
OTB Logger	Record of DIS PDUs for Data Collection & Analysis	DIS 2.04
Simulyzer	Record of DIS PDUs for Data Collection & Analysis	DIS 2.04

Table 1 Exercise Assets

3.2 Description of System Components

This section discusses the description, functionality and operation of the system components, which includes the Government Furnished Equipment (GFE) and their integration with the hardware at the 160th SOAR facility.

3.2.1 MH-60K CMS

The MH-60K CMS is a full-motion high-fidelity training device. It replicates the full functionality of the respective aircraft systems including; Forward Looking Infrared Radar (FLIR), Multi Mode Radar (MMR), Digital Map (DigMAP) and Integrated Avionics System (IAS). This allows for realistic tactical training within a fully tailorable geo-specific virtual environment. Tactical Operations include but are not limited to: Night Vision Goggles (NVG), Radar Avoidance, Threat, Ship Operations, Qualification and Continuation Training, and Mission Rehearsal. A DIS compliant interface allows local area and long haul networking of these training devices and allows for collaborative mission planning, execution and Mission Rehearsal.

3.2.2 MH-47 CMS

The MH-47E CMS is a full-motion high-fidelity training device. It replicates the full functionality of the respective aircraft systems including; FLIR, MMR, DigMAP and IAS. This allows for realistic tactical training within a fully tailorable geo-specific virtual environment. Tactical Operations include but are not limited to: NVG, A/R, Threat, Ship Operations, Qualification and Continuation Training, and Mission Rehearsal. A DIS compliant interface allows local area and long haul networking of these training devices and allows for collaborative mission planning, execution and Mission Rehearsal

3.2.3 MC-130E BMC

The MC-130E BMC is not an asset at the 160th SOAR facility but was used via a secure long haul T1 capability to Hurlburt Field. The MC-130E BMC replicates the fire control systems of the MC-130E allowing simulated weapons delivery, sensor/weapons alignment, and diagnostic maintenance operations. The visual, radar, sensor, and electromagnetic combat environment databases are correlated to each other for real-time display. The real-time display is a high-resolution perspective scene generator, including day/night, radar, All Light Level Television (ALLTV), and Infrared Detection Set (IDS) capabilities. Databases for simulated strike operations against a wide variety of targets including fixed cultural features, and fixed or moving models in the applicable visual, electromagnetic, sensor, and radar presentation. A HLA/DIS compliant interface allows for collaborative mission planning, execution and Mission Rehearsal.

3.2.4 TOPScene

TopScene is a deployable mission rehearsal system. It was used to familiarize the pilots with the terrain prior to execution, and to provide in flight visuals for CMS pilots. TOPScene uses computer generated imagery based terrain databases that allow crews and planners to preview routes and mission areas in three-dimensional real-world target areas prior to mission execution. TopScene also has the capability to be networked in a DIS/HLA compatible environment and can augment the air component by providing a free-flying networked air vehicle.

3.2.5 OTB

OTB was used as the SAF for all non-simulator aviation, ground, and threat assets in the exercise. OTB is a flexible SAF system allowing the user to create varying scenarios using a wide range of units and behaviors. Specific capabilities used in the mission included: rotary wing aircraft to fill out the needed flights, fixed wing aircraft to provide fire support and intelligence, infantry forces to infiltrate and secure target areas, and threat infantry and air defense systems .

OTB models equipment such as weapons, sensors, communications and countermeasures but also fully represents the dynamic capability of entities enabling them to pursue various navigation modes as well as engage in several combat modes (air-air, air-ground, ground-ground, ground-air). Prior to mission execution, a scenario is constructed according to the plan developed by the respective commanders. As the scenario unfolds, the user is presented with up-to-date information on a 2-D display (and any attached 3-D) system. At all times the user has the ability to modify the scenario to respond to situational changes.

3.2.6 Builder

The Builder Program was established at the Naval Research Laboratory with the responsibility to support EW related system analysis. Through computer simulations of complex electromagnetic environments, scenarios are developed that provide unique advantages in designing, specifying, and evaluating EW systems.

ENEWS, through a DIS compliant interface, provided a dynamic two-dimensional view of virtual and computer generated forces (CGF) air component assets as they ingress along the depicted tactical route structure.

3.2.7 Simulyzer

Simulyzer is a software tool used for data collection, analysis, and exercise playback in the DIS environment. Simulyzer was developed by TASC as a data collection and analysis toolset and has grown to be an effective After Action Review (AAR) system. Simulyzer's graphical user interface (GUI) based modules provide real time network troubleshooting and monitoring of PDU data during collection and is an efficient analysis tool for PDU data. This software runs on the IRIX and SunOS UNIX platforms and is designed on the kernel module criteria that ensures system flexibility, usability, and extensibility.

Simulyzer's flexibility allows for the development of user specified modules that can be added in order to perform specific tasks. Basic tasks are: data logging of DIS PDU data from the local area network (LAN), PDU filtering, monitoring and playing COMM traffic and outputting the sound through the systems audio ports, exercise playback with variable speeds and time in log file, and PDU generation to augment an exercise.

3.2.8 SoundStorm

SoundStorm was used to support the Ranger mission. SoundStorm 3D is a DIS compliant three-dimensional battlefield sound generator. Sounds are generated as a result of the SoundStorm receiving Entity State, Fire, and Detonation DIS Protocol Data Units (PDUs) from other DIS simulations on the network. The SoundStorm hardware consists of an Intel Pentium PC running the LINUX operating system. This PC is equipped with two high-fidelity sound cards and four amplified speakers to allow for a four-channel "surround sound" aural effect. The system allows the user to attach an "ear point" to a specific DIS entity (e.g. soldier) at any location on the battlefield. Sounds are heard from the perspective of the entity that the ear point is attached to. Six-dimensional aural realism is maintained by biasing the sound output slightly to the left/right, front/rear, and above/below. In addition, the volume level of the sound output is varied to account for the distance of an entity from the selected ear point. SoundStorm contains digital sounds for aircraft, ground vehicles, direct and indirect fire munitions, and missiles.

In the 160th SOAR STOW exercise, three SoundStorm systems were utilized. SoundStorm was present in the Company Commander, Special Forces, and one Platoon Leader cells. Ear points were attached to the entities corresponding to the locations of the role players on the battlefield in an effort to create a sensation of being immersed in battle. The company commander was forced to react to combat situations and communicate on tactical radios by having to overcome the loud volume of the battlefield sounds as they would in the field. During the exercise, battlefield sounds contributed to the overall realism of the training experience by helping to immerse the soldiers in a simulated battle environment.

3.2.9 ASTi Radios

DIS radio communications were primarily conducted using various configurations of the ASTi DACS integrated with the MH-60 and the MH-47 simulators, hand-held radio control terminals and SimPhonics PCs at Ft. Campbell. The T-1 DIS/HLA connections also permitted communications with the MC-130E simulator at Hurlburt Field. The live-to-virtual communications bridge was fulfilled using SimPhonics PCs with custom interface boxes. Hand-held RCUs provided individual role players with the capabilities to communicate on multiple radio networks with simulators and live aircraft in the exercise. Communications were in both clear and secure radio modes with simulated crypto tones. The individual locations of the radio controllers are depicted in Figures 3 and 4. The DIS to live radio interface and the RCU diagrams are shown in Figures A-2 and A-3 in Appendix A.

Communications were primarily conducted over both ASTi radio simulators and GFE live radios. The communication inventory at Ft. Campbell consisted of four ASTi Digital Aural-cue/Communications System (DACs), five Remote Interface Units (RIUs), seventeen EBC Radio Control Units (RCUs), two helicopter Combat Mission Simulators (MH47 & MH60 CMSs) audio systems, two SimPhonics PCs and eight live-to-virtual interface boxes.. In addition to the Ft.Campbell inventory an MC-130E aircraft simulation system and various live GFE radios were used in the exercise.

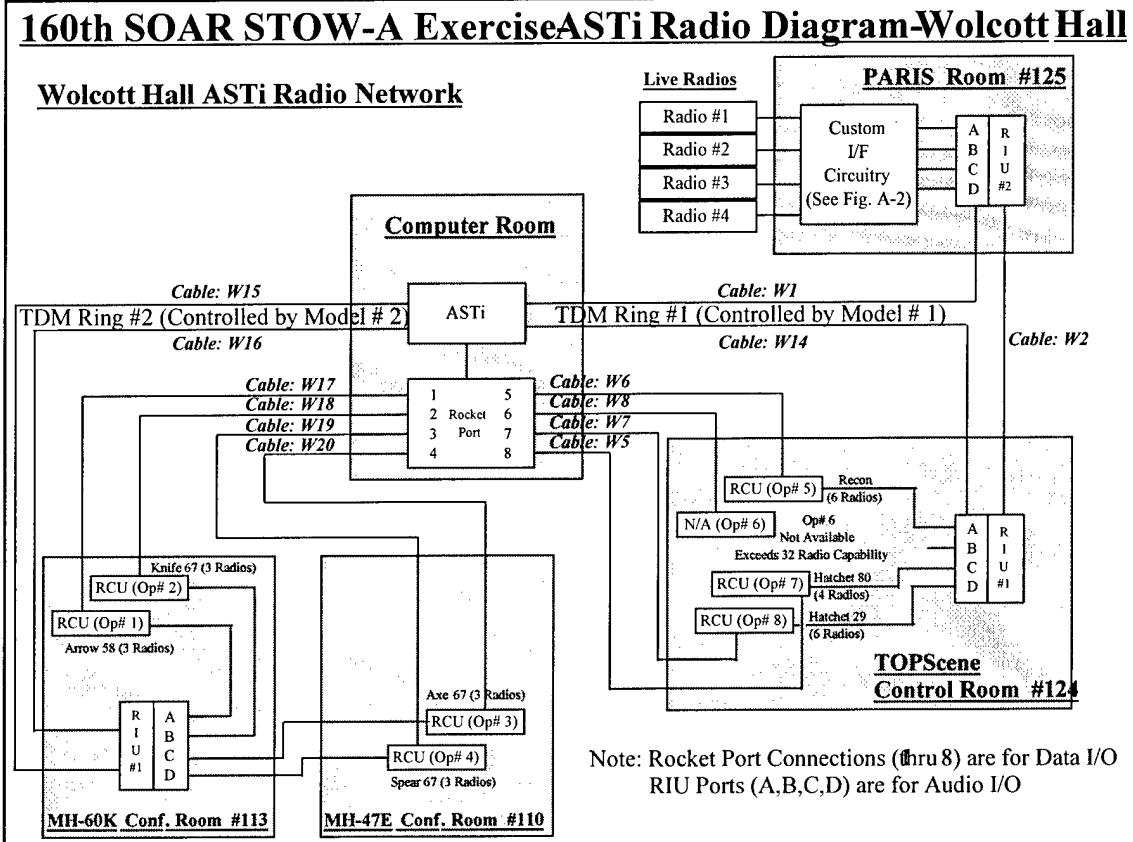

Figure 3 ASTi Radio Diagram for Wolcott Hall

November 30, 1999

160th SOAR STOW-A Exercise -ASTi Radio Diagram-Frank Hall

Figure 4 ASTi Radio Diagram for Frank Hall

3.2.10 MetaVR

MetaVR provides a low cost, high fidelity 3-D viewer. For the exercise, this system was used as a Special Forces “eyes on target”, and as a situational awareness and demo tool in the exercise control room in Frank Hall. Its database was generated using a MetaVR tool set that converts OTB CTDB format into MetaVR MDB terrain.

3.2.11 SVS

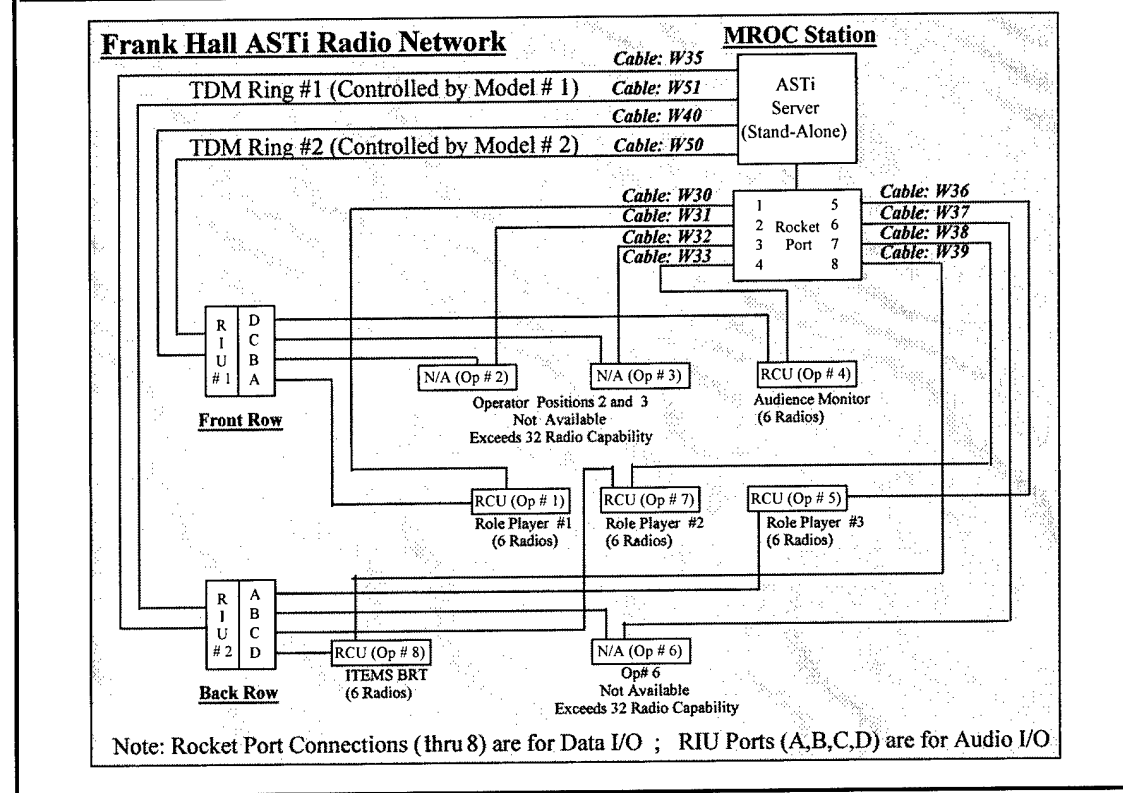
To fill the need for more 3-D viewers, four SVS stations were brought into the exercise. The SVS stealth permits the user to participate in the exercise as an actual entity, or view the battlefield strictly as a stealth. SVS was not operational during the exercise since a one geo-cell terrain database was loaded onto the system rather than a size the system could handle. There were also other random hardware failures.

3.2.12 HLA/DIS Network

Distributed simulation facilities were integrated using DIS protocol version 2.0.4 and HLA RTI 1.3v6/SOF FOM 1.0 over a dedicated T-1 link. This network link provided a means to

simulate the warfare environment for various SOF scenarios and to measure the goals and objectives established for the STOW-A effort. KIV-7HS encryption devices are employed at both sites to ensure the security of the data in the exercise.

An advanced distributed simulation network was used to provide a mechanism to simulate virtual and constructive entities under a common scenario. The basic architecture for this advanced distributed simulation network is depicted in Figures 5 and 6.

From a functional perspective, each test site provided an HLA interface to its simulators and simulation applications except for the radio simulation, which will be in DIS. The DIS interface will implement the DIS (Version 2, fourth DRAFT (2.0.4) standard (including voice communications), and will send local and receive remote truth data.

Please refer to high-level network architecture diagram depicting Hurlburt Field and Ft. Campbell networks (Figure 5). For this exercise all information transmitted via the T1 will be HLA protocol with the exception of the ASTi Radio traffic. DIS Radio Filters at each site allow DIS radio related PDUs to be inserted into the HLA network to facilitate ASTi radio communications.

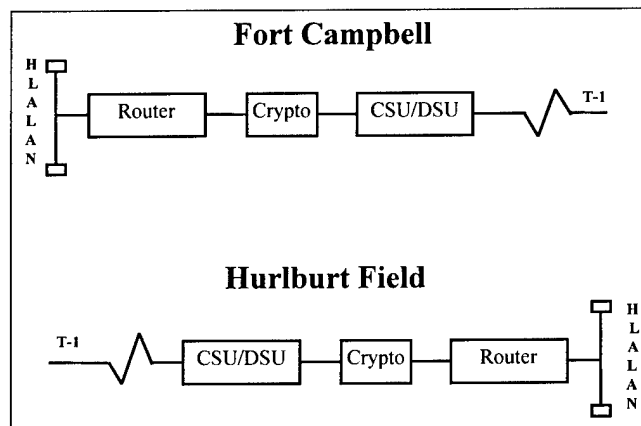

Figure 5 Network Connectivity Architecture

November 30, 1999

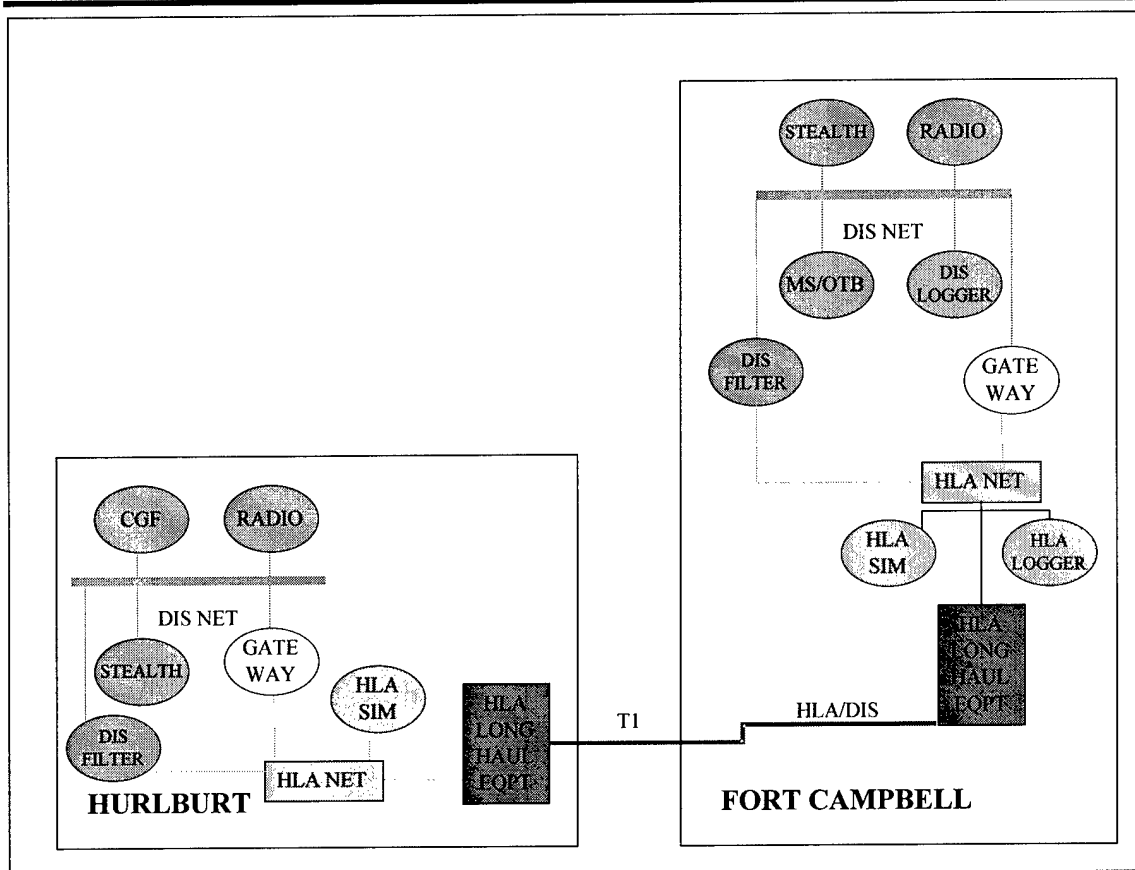

Figure 6 Hurlburt Field - Ft. Campbell HLA Longhaul Architecture

3.2.12.1 HLA SIM

There are four HLA Federates that will be part of the STOW-A Federation execution:

- MH-47
- MH-60
- Fort Campbell HLA Gateway
- MC-130E

3.2.12.2 HLA GATEWAY

The STRICOM HLA Gateway version 3.2 is being utilized to allow OTB and other DIS native devices to interoperate with other HLA Federates. The Gateway is a protocol translator between DIS and HLA. It will use SOF FOM 1.0 (based on RPR-FOM 0.5) and RTI 1.3v6. For the STOW exercise the RTI EXEC and FEDEX processes will run on the Gateway. The Fort Campbell Gateway will create the federation by being the first federate to join.

3.2.12.3 DIS FILTER

Both Hurlburt and Campbell have a DIS Filter system. Because the ASTi radios do not have an HLA interface at the time of the STOW exercise, the radios operate with a DIS interface.

The DIS Filter also known as the XCAU provides the capability to mix DIS radio packets and HLA packets on the T1 line. The DIS Filter runs on an SGI machine and is configured with two network cards. One network card is connected to the DIS network the other card is connected to the HLA network. The application filters DIS Radio traffic over on to the HLA network. On the other side a similar filter receives the radio traffic and will bridge them over to the local DIS network.

3.2.12.4 FOM

The SOF Federation Object Model (FOM) version 1.0 is based on RPR-FOM 0.5.

3.2.12.5 RTI

The RTI being used for the STOW-A exercise is the DMSO RTI 1.3v6.

3.2.12.6 VR-Link 3.4

Each CMS is equipped with a middleware COTS product, VR-Link 3.4, from MaK technologies. VR-Link represents the CMS as a federate and performs all communications between the RTI and the Host custom software. The middleware and custom software reside on the Origin 2000 machine on each CMS.

3.3 Terrain Database and Scenario Development

Terrain database development was an extensive effort that involving several government agencies and contractors. The database was generated from DTED/DFAD information gathered from real world intelligence assets. Because of the level of detail, and how this detail was obtained on the area in question, the entire database effort was classified. Databases were developed for the CMS systems at Ft. Campbell, the MC-130E simulator at Hurlburt AFB, OTB CTDB format, FLT format for SVS, and MDB for MetaVR. The database, covered four geocells and depending on the format provided data such as trees, roads, contours, bodies of water, power lines, buildings, and more.

The initial scenario concept was developed by the 160th SOAR. The final operations orders and plans were developed jointly by the 160th SOAR, the 75th Rangers, and the 19th Special Operations Squadron (SOS) training elements as part of the planning requirements for the exercise. The scenario depicted a joint special operations force conducting a helicopter combat assault in support of a light infantry raid and extraction. The force package provided to mission planners included an MC-130E, AC-130U, AWACS, and F16s in addition to the rotary-wing assault force. These assets provided direct support to the 75th Ranger Regiment ground element. All forces involved in the mission were under the operational command and control of a joint staff. The AMC and GFC participated and controlled the exercise from a live MH-60 flying in the vicinity of the 160th SOAR Training Facility.

4. Conduct of the Exercise

4.1 Troop Training

In order to get the maximum benefit from the exercise, the same group of Rangers were used to set up the OTB ground scenario for both missions. The scenario changed based on what the ground mission commanders were provided as information for each run. So, while the two missions were unique, technical training time was minimized. The OTB training period for the Rangers occurred the week prior to the exercise, and was run by Ft. Bragg government personnel.

4.2 Exercise

The actual training exercise window was three days per mission. This period included two days to execute the exercise and one day for planning and implementing scenario modifications if required. The missions were executed on October 25-26 and October 28-29 by different Ranger, Special Forces, and 160th elements.

The first training mission started as scheduled on the evening of October 25 and ended October 26. The technical and tactical objectives were met. At the conclusion of the first mission a series of After Action Reviews (AARs) were conducted to discuss tactical and technical issues. Upon completion of the AARs the units revised the tactical plan and the technical procedures were modified in preparation for the second exercise.

The second mission started as scheduled on the evening of October 28 and ended October 29. Although this was the final mission, some new technical problems were discovered and are captured in Chapter 5 and Appendix C

5. Observations and Lessons Learned

Observation #1

The schedule of training activities at the 160th SOAR facility had an adverse impact on the integration and testing of the STOW-A exercise.

Discussion #1

The 160th is a training facility and its training takes precedence over all other activities. Last year, we conducted a Mission Rehearsal at each SSE that cut into the developmental time. This year that was not done but the integration periods were not well utilized since the technical development was not completed by the SSEs and the SSEs did not slip to accommodate the technical slips. It could be suggested that the SSE be focused on technical milestones and adjusted to meet their delivery.

Lesson Learned #1

All efforts need to be planned with both technical and schedule considerations.

Observation #2

ASTi integration effort was more than anticipated.

Discussion #2

The integration of the ASTi radio assets and the live to simulation communication bridge was a key element in the success of the exercise. However, the process of determining the initial requirement and a growth in the communication requirements caused additional labor costs to effectively integrate the systems. This growth was due in part to the experimental nature of the sim to live bridge, and difficulties associated with live equipment failures and user error.

Lesson Learned #2

Better requirement analysis and definition of scope is essential at the start of the engineering effort.

Observation #3

The Distributed Interactive Simulation Interface Unit (DIU) only has the capability to pass thirty-one closest entities into the visual scene. In an exercise there are usually at least triple that number of entities and frequently more.

Discussion #3

During the development of the DIU, which is the interface between the host and DIS network, it was documented that the capability existed to display the forty closest entities to the simulator. However, after the development process started it was discovered that the host reserves nine slots for special effects such as tanker drogue and sling loads. This capability presented several anomalies during the exercise when the visual scene did not depict the current situation based upon the actions of the simulator. This was especially noted at the times when troops were deployed from the aircraft.

Lesson Learned #3

This is a hardware limitation this should be considered during scenario development and mission planning.

Observation #4

There were numerous problems with terrain creation and correlation over all the systems (CMS (Ft. Campbell and Hurlburt AFB), OTB, SVS, and MetaVR)

Discussion #4

The OTB, SVS, and MetaVR database all came from the same parent set of data obtained from LMIS and converted into a FLT format. From FLT, a four geocell CTDB (1 detailed Geo Cell and contour lines for the other 3 cells) was developed, the SVS FLT database, and MetaVR MDB format. The initial requirements analysis for the databases called for a single geocell populated with high detail, and no texturing. This was later determined to be unusable, and database changes had to be made. This required modifying FLT files which require special hardware not available at the 160th, so a back and forth process between subcontractors was required.

Lesson Learned #4

A more thorough initial database analysis phase needs to avoid back and forth revision cycles. Also of note is that many systems require that a certain FLT format be used, while other formats are unusable. This information should also be determined during the initial analysis phase.

Observation #5

Occasional network anomalies occurred with interactions between OTB, CMS, and HLA system components.

Discussion #5

The final mission had a massive network failure due to what was believed to be anomalous hardware. An OTB machine crashed, and somehow interacted with the network to create a snowball effect. The problem required that all affected machines be rebooted, including network servers, in order to stop the persistent problem.

Lesson Learned #5

More network experimentation needs to occur by forcing system errors on the various components and determining that correct recovery actions are automatic.

Observation #6

Several legacy network items were 10Mbs and need to be upgraded to 100Mbs.

Discussion #6

If there is a 10Mbs component in a section of network, the whole section is brought down to that speed even if all other components are 100Mbs. An analysis had been done previously illuminating this problem, but the findings were not turned into a solution. This is a relatively inexpensive item to fix.

Also note that the ASTi servers are 10Mbs. Upgrading these items is a good deal more complicated and requires research.

Lesson Learned #6

Double check the results of any previous analyses that have been performed to ensure that no results were lost.

Some potential solutions could include:

- placing the ASTi network could be put on a separate network and can be done by buying several 10/100Base-T-switching hubs and at least four FOTs (fiber optic transceivers). Two or more dual-ported LINUX PC's to be used as programmable routers. This would also require somebody to set things up and program the net routers.
- a more expensive option w/ added flezability and room for growth, buy two powerhubs; one for Wolcott hall, and one for Frank hall. Connect existing fiber between buildings as a dual-attached FDDI backbone for high bandwidth. This offers high-bandwidth access for a greater number of workstations, but also allows the use of VLANs with capability of routing. However, the netrouter LINUX workstations to filter on the contents of the packets to optimize network performance would still be need and someone would need to set it up.
- the most expensive option, upgrading to 100Mb/s.
- the Sun based Simulyzer could be run on an INDY instead of the lower end Sun

Observation #7

90% of all ASTi problems in the later rehearsals and missions occurred from user error and problems that were recorded in the previous STOW exercise.

Discussion #7

Literally hundreds of hours were spent tracking down previously known and user error problems (e.g., the squelch knob) because a) known problems were never disseminated, and b) a certain level of operator knowledge was assumed going into the missions. Given that these are boxes that all parties are supposed to be familiar with, this is not a bad assumption. There were ASTi instruction times available for anyone not comfortable with their proper usage, but the learning time was not used as all parties claimed fluency.

Lesson Learned #7

Data capture and user input from these exercises needs to be formalized and disseminated prior to any follow-on STOW exercises, along with proper user training.

Observation #8

The current version of SVS is actually a beta revision and cannot support terrain databases approaching a full geocell in size.

November 30, 1999

Discussion #8

SVS had numerous problems with entity loads, terrain anomalies due to poor memory usage that prevented even a full geocell being displayed, and a large set of mysterious configuration requirements that are not documented anywhere and caused a configuration nightmare.

Lesson Learned #8

SVS is not yet ready for full exercise support. Recommend inspection of the upcoming new release in December 1999 for applicability to simulation needs.

Observation #9

OTB fixed wing aircraft appear to be "jumping" in the CMS out-the-window views.

Discussion #9

Fixed wing aircraft (FWA) in OTB are given a flight altitude, and stay within 50 feet of that altitude. Because of the speed at which this change occurs, the CMS sees a jerky transition. This could be due to the 10Mbs network not allowing speedy updates, or the dead reckoning algorithm in the CMS systems which is old and performs a large interpolation. No other 3-D viewers had a problem with smoothing the movement.

Lesson Learned #9

Inspect all anticipated assets in the simulators out-the-window view prior to slating them for exercise usage.

6. Conclusion

The 160th SOAR has a staff that has been trained to plan and execute training exercises in a DIS/HLA environment. The facility also has in its possession a SOF OTB baseline, Simulyzer, MetaVR, and all associated hardware to provide communications in both a live and virtual environment.

7. Points of Contact

ADST II 160th SOAR Team

Bryan Cole	Project Director	407-306-4062
Lee Napravnik	Lead Systems Engineer	407-306-4040
Jim Page III	System Engineer (ASTi)	407-306-1900
Ivan Carbia	System Engineer (HLA)	407-306-4047

STRICOM

November 30, 1999

Tom Lasch	Project Director	407-384-3679
Alesya Paschal	Project Engineer	407-384-3867

Customer Points of Contact

CW4 Mike Durant	160 th SOAR Project Officer	270-798-1817
Chuck Gehring	Sherikon – STOW Battlemaster	270 – 798 - 1385

Acronym List

AAR	After Action Review
ADST	Advanced Distributed Simulation Technology
ALLTV	All Light Level Television
AMC	Air Mission Commander
ASTi	Advanced Simulation Technology Inc.
B/E	Bits per entry
bps	Bits per second
BLUFOR	Blue Forces
BMC	Battle Management Center
CDRL	Contract Data Requirements List
CGF	Computer Generated Forces
CM	Configuration Management
CMS	Combat Mission Simulator
CSAR	Combat Search and Rescue
DC	Data Collector
DIGMAP	Digital Map
DIU	Distributed Interactive Simulation Interface Unit

DIS	Distributed Interactive Simulation
DO	Delivery Order
ENEWS	Effectiveness of Naval Electronic Warfare System
FLIR	Forward Looking Infrared Radar
FOM	Federation Object Model
GFC	Ground Force Commander
GFE	Government Furnished Equipment
GUI	Graphical User Interface
HE	High Explosive
HLA	High Level Architecture
IAS	Integrated Avionics System
IFF	Identification Friend, Foe
IPT	Integrated Product Team
JRTC	Joint Readiness Training Center
LAN	Local Area Network
LOS	Line of Sight
Mbs	Megabits per second
MMR	Multi Mode Radar
NGV	Night Vision Goggles

OPFOR	Opposing Forces
OPORD	Operations Order
OS	Operating System
OTB	OneSAF Testbed
PASS	PDU Adapter Software System
PDU	Protocol Data Unit
POC	Point of Contact
PVD	Plan View Display
RCU	Radio Control Unit
RIU	Radio Interface Unit
RRD	Ranger Reconnaissance Detachment
RTI	Run Time Infrastructure
SAF	Semi-Automated Forces
SME	Subject Matter Expert
SAIC	Science Applications International Corporation
SOAR	Special Operations Aviation Regiment
SOF	Special Operations Forces
SOS	Special Operations Squadron
SOW	Statement of Work

SSE	Sub-system Evaluation
STOW-A	Synthetic Theater of War-Architecture
STRICOM	(US Army) Simulation Training and Instrumentation Command
TBD	To Be Determined
TC	Test Controller
TRAC	TRADOC Analysis Center
UDP	User Data Protocol
VC	Voice Channel
VTC	Video Teleconference
VV&A	Validation Verification and Accreditation
VS	Virtual Simulation Test

Appendix A- Additional Drawings

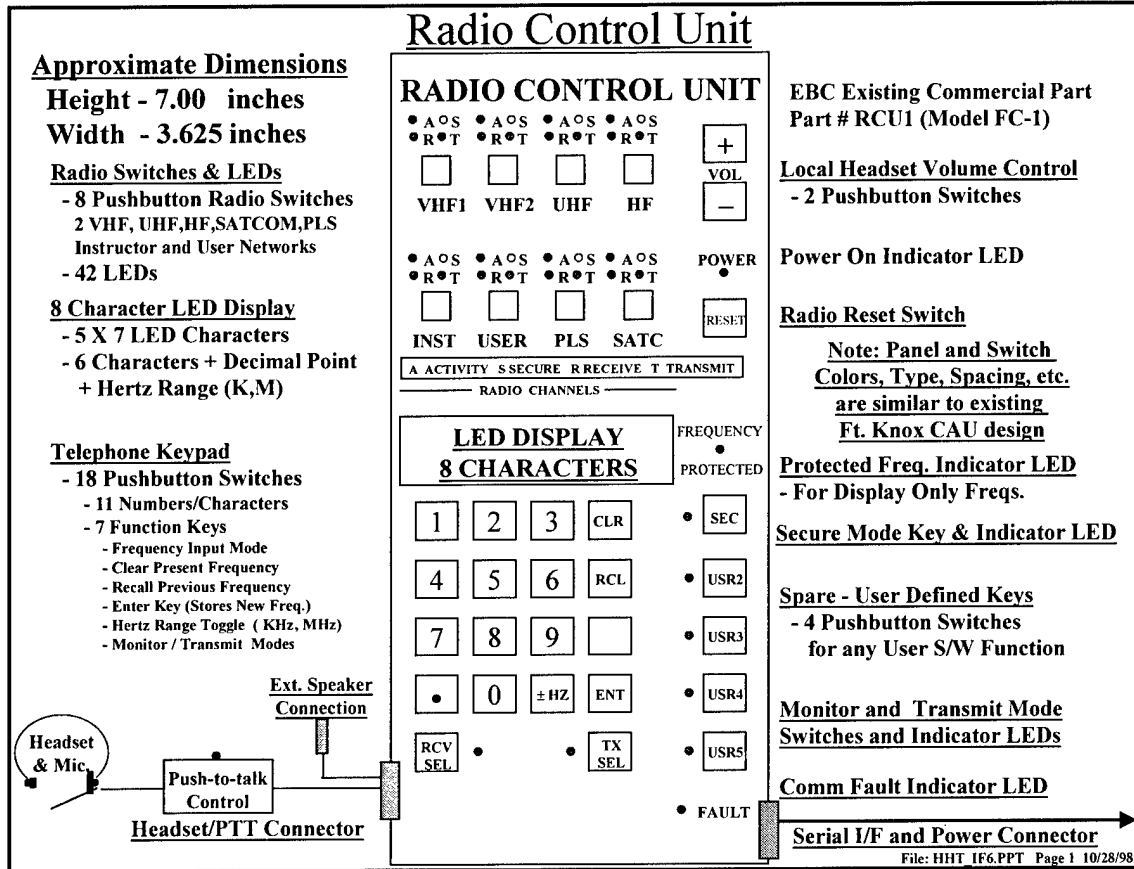

Figure A-1 Radio Control Unit (RCU) Hand Held Terminal

Appendix B- DIS Enumeration Table

DIS 2.0.4 ENUMERATION TABLE

Model/Entity Type	Ent Kind	Dom	Ctry	Cat	Subcat	Specific	ESIG Entity Map (Model #)
MC-130H	1	2	225	2	9	3	3
MC-130E	1	2	225	4	1	8	3
F15C	1	2	225	1	5	3	3
E8_JSTARS	1	2	225	2	11	0	3
RivetJoint	1	2	225	2	12	0	3
EC130	1	2	225	2	13	0	3
E2C_AWACS	1	2	225	2	14	0	3
IDAP	1	2	225	25	1	6	3
BMP2	1	1	222	2	2	1	1
FLAT FACE RADAR TRUCK (XMTSS)	9	1	222	2	2	3	13
CH-47D	1	2	225	25	2	1	21
MH-60G	1	2	225	25	1	2	
MH-47E	1	2	225	25	1	1	23
MH-60L	1	2	225	25	1	4	23
MH-60K	1	2	225	25	1	3	23
IDAP	1	2	225	25	1	5	23
XXX SOF TEAM (SOLDIERS)	3	1	225	1	102	1	36
XXX SOLDIER (IC M16A2)	3	1	225	1	1	1	35

November 30, 1999

Model/Entity Type	Ent Kind	Dom	Ctry	Cat	Subcat	Specific	ESIG Entity Map (Model #)
XXX SOF Law (DI Javelin)	3	1	225	1	82	1	
MC-130E	1	2	225	4	1	8	3
Rifleman (Red) (DI Mg)	3	1	222	1	206	1	
Wounded Soldier	3	1	225	1	1	2	
XXX Truck Cargo (ZIL FDC)	1	1	222	7	4	0	
Precious Cargo	1	1	225	14	1	0	
US Chevy Truck (M977)	1	1	225	6	21	0	
60mm Mortar (M224)	1	1	225	10	2	0	
SA-7 TM	3	1	222	1	1	233	
ZSU-23	1	1	222	4	18	0	38
Ranger M203 (IC AT8)	3	1	225	1	73	0	
Ranger C.O.	3	1	225	1	11	0	
Ranger X.O.	3	1	225	1	17	3	
Ranger SQD LD	3	1	225	1	52	2	
M240 TM	3	1	225	1	52	3	
US Sniper	3	1	225	1	24	2	
RAAWS (Dragon Team)	3	1	225	1	81	3	
SAW Heavy Gunner	3	1	225	1	116	1	
Ranger Plt Ld	3	1	225	1	17	5	
Rgr Tm	3	1	225	1	17	6	

November 30, 1999

Model/Entity Type	Ent Kind	Dom	Ctry	Cat	Subcat	Specific	ESIG Entity Map (Model #)
P.C. (Precious Cargo)	4	1	0	0	20	0	
LT MG	3	1	222	1	216	2	
SNIPER (Red)	3	1	222	1	208	1	
2S6	1	1	222	28	10	1	
BTR60PU	1	1	222	2	8	5	
SA_15	1	1	222	28	48	0	
M855 round	2	1	225	2	1	5	
M136 round	2	1	225	2	8	1	
PS round	2	1	222	2	2	0	
M789 round	2	9	225	2	3	1	
Hellfire round	2	2	225	1	3	0	
Stinger round	2	1	225	1	15	1	
Hydra 261 round	2	9	225	2	21	3	
Hydra 255 round	2	9	225	2	21	2	
M59 round	2	8	225	2	5	2	
30mm HE 2S6 round	2	3	222	2	2	2	
SA 19 round	2	1	222	1	31	0	
Gauntlet round	2	1	222	1	27	0	

Appendix C- Miscellaneous Technical Notes

Terrain:

- CTDB tools to merge large database cells together are not functional in the OTB baseline and have never been. The Topographical Engineering Center (TEC) uses an in-house set for their work, all others use smaller databases with other commercial tools.
- All FLT formats are not created equal (there are multiple variations of feature content/representation), and different commercial software packages operate on separate versions (e.g., SVS and MetaVR)
- FLT modification tools are expensive and cumbersome, making FLT terrain difficult to manipulate quickly.

OTB:

- An OTB FWA tanker "jumps" in the CMS. Replace Mak VR Link algorithm with higher order algorithm.
- Baseline RWA model is Apache based, and as such was not useable for SOF aircraft. This necessitated the replacement of the "guts" on each aircraft with Apache guts. Note: this was a due to a lack of GFI aircraft data provided during the original RWA development.
- Under extreme network load, FWA sometimes slip between ticks and nose-dive into the ground. Solution was turning off ground collisions, which worked great.
- Scenario saves and reloads have problems with reactivating entities that were saved deactivated (further study is needed).
- Compiling in MES structures must be done carefully with respect to Z so that entities can still enter. The margin of error is only about half a meter.
- A unit level "IC move" task must be created for effective troop usage.
- IC entities frequently will "not move" for no apparent reason (further investigation is required).
- Air mount seemed to have some problems we have been unable to duplicate. Could be user error, but must investigate
- Certain RWA characteristics are less than optimal (landing, creation above the earth, some behaviors) and must get fixed.

Network:

- When the 60 CMS is taken off the net at the it is still kicking out PDUs so all simulations are picking it up. It looks like it is diving into the ground, spinning around, and other anomalous behavior.

- The Gateway and DIS interface require frequent rebooting or anomalies occur.
- Each OTB machine should have been forced to a set site/host id pair for easy PDU identification.

SVS:

- The current version of SVS stores the entire terrain and all software functions into memory, thus limiting the standard system to about a 1K by 1K detailed area.
- Each SVS system was upgraded to 640 Mb of memory to enable it to load the 20k by 20k area of interest. Because of the above memory limitations, this was an extremely slow load, and could not support much texturing.
- In general this is a painful system to setup and run, it is a beta system and not of exercise quality. For example, linking in a database requires the modification of six data and batch files, terrain offsets often conflict with graphic offsets, linking new models requires modification of several files which are very much non-intuitive, databases must start with a (0,0) origin in the FLT files or correlation is non-existent.
- Cannot handle entity count spikes without locking up. The system capacity was 89 entities on the pantherleap database.
- Very small model set for entities, providing little to no flexibility for display.
- The system (models and terrain) is not extensible without the full suite of openflight modification tools.
- Contains reams of data baggage from ModSAF 3.0 which is unnecessary and clogs the system making it difficult to use, even for an experienced ModSAF user/developer
- A new version of SVS is coming out in December 1999 which may prove more useful. As is the system is useless for an exercise, especially compared to what MetaVR provides.

MetaVR:

- Provides a large suite of conversion utilities, although the FLT to MDB never worked correctly, but FLT isn't always FLT.
- CTDB to MDB conversion does not convert buildings and only runs on SGIs. You can manually paste buildings in later though, although small correlation problems can occur. This tool is not part of their standard release set. The tool is easy to use and provides perfect correlation with the CTDB that it originated from.
- A converted database must have a default texture applied to it to make it usable, otherwise it appears to be "blacked out". The default texture map is provided with the software and can be modified.
- You can enter an MES building in MetaVR as a stealth and see all the applicable details.

Soundstorm:

- Creates piles of networks traffic when it is functioning.

- Startup procedures require an explicit path to the sstorm executable being used. Left to itself, the system finds some other similar named executable which reboots the machine
- The developers (RBD) are unwilling to provide software support without a maintenance license in place (about \$1500 per year, per box).