

*AW 25 Apr 51*

NACA TN 2286

# NATIONAL ADVISORY COMMITTEE FOR AERONAUTICS

TECHNICAL NOTE 2286

PRELIMINARY INVESTIGATION OF A NEW TYPE OF  
SUPERSONIC INLET

By Antonio Ferri and Louis M. Nucci

Langley Aeronautical Laboratory  
Langley Field, Va.



Washington  
April 1951

Reproduced From  
Best Available Copy

DISTRIBUTION STATEMENT A  
Approved for Public Release  
Distribution Unlimited

20000816 126

NATIONAL ADVISORY COMMITTEE FOR AERONAUTICS

---

TECHNICAL NOTE 2286

---

PRELIMINARY INVESTIGATION OF A NEW TYPE OF  
SUPERSONIC INLET

By Antonio Ferri and Louis M. Nucci

SUMMARY

A supersonic inlet with supersonic deceleration of the flow entirely outside of the inlet is considered. A particular arrangement with fixed geometry having a central body with a circular annular intake is analyzed, and it is shown theoretically that this arrangement gives high pressure recovery for a large range of Mach number and mass flow and therefore is practical for use on supersonic airplanes and missiles. For some Mach numbers the drag coefficient for this type of inlet is larger than the drag coefficient for the type of inlet with supersonic compression entirely inside, but the pressure recovery is larger for all flight conditions. The differences in drag can be eliminated for the design Mach number.

Experimental results confirm the results of the theoretical analysis and show that pressure recoveries of 95 percent for Mach numbers of 1.33 and 1.52, 92 percent for a Mach number of 1.72, and 86 percent for a Mach number of 2.10 are possible with the configurations considered. If the mass flow decreases, the total drag coefficient increases gradually and the pressure recovery does not change appreciably. The results of this work were first presented in a classified document issued in 1946.

INTRODUCTION

The deceleration of air from supersonic to subsonic Mach numbers is an important problem that is encountered in the design of supersonic ram jets and turbojets. The possibility of the practical use of the ram-jet or turbojet systems for airplanes depends to a large extent on the high pressure recovery of the air inlet.

An inlet designed so that all the supersonic part of the compression was internal was analyzed in reference 1, which showed that

high pressure recovery is possible if the Mach number corresponds to the design Mach number and the mass flow corresponds to the design mass flow. Reference 1 also showed that the pressure recovery decreases notably and abruptly if the Mach number and the mass flow which must go into the inlet decrease from the values fixed for the design conditions. The external drag which can be very small for the design conditions (fig. 1(a)) changes suddenly, also, and becomes very large when the Mach number or the mass flow decreases from the values fixed for the design conditions because in this case a strong shock occurs in front of the inlet (fig. 1(b)). The pressure recovery also decreases rapidly if the Mach number is increased in comparison with the design Mach number.

The limitation of the starting conditions fixes the maximum possible contraction ratio of the diffuser that permits the normal shock to enter. A strong shock inevitably occurs inside the diffuser in the divergent part and limits the maximum obtainable pressure recovery. The subsonic losses are also large because the strong shock tends to produce separation.

When the free-stream Mach number is lower than the design Mach number and the free-stream Mach number is attained by decreasing speed from a Mach number higher than the design Mach number, two equilibrium conditions are possible and it is possible to pass from one condition to the other with an abrupt "jump" of flow characteristics. The reason for this jump, which can be dangerous for a supersonic airplane, is as follows: If the Mach number is higher than the design Mach number and the strong shock is inside the inlet, when the free-stream Mach number decreases, the limitation of the starting conditions no longer exists because the strong shock has passed the minimum section and therefore the contraction ratio can be smaller than the fixed value for starting; the converging part of the diffuser remains supersonic even though the Mach number is lower than the design Mach number. This condition is only partly stable, however, and it is possible to pass abruptly from this condition to the stable condition having a normal shock in front. When the internal shock is near the minimum section, if the back pressure is increased slightly, the internal shock jumps outside the inlet and remains in this position because the size of the throat is too small to permit the shock to go inside again. The passage from one equilibrium condition to the other produces abrupt changes in the values of mass flow, drag, and pressure recovery, variations which increase if the difference between the flight Mach number and the starting Mach number increases.

These phenomena are characteristic of the diffuser having fixed geometry and internal supersonic compression. It is therefore natural to think that better results can be obtained with either variable-geometry diffusers or diffusers with external supersonic compression.

Some work in this direction was started at Göttingen and was presented by Oswatitsch and Böhm (references 2 and 3). Before the Oswatitsch work was known in the United States, independent work in this field was begun by the NACA using different criteria. Some results of this work are summarized in the present paper, which was originally issued as a classified document in 1946.

The problem that Oswatitsch had in mind was the design of an air inlet for missiles that must operate only at high Mach numbers and therefore must have high pressure recovery and low drag in this Mach number range. He therefore chose a compromise between external and internal compression for his inlet. In his design the disadvantages of the type of inlet with all internal compression were reduced but not eliminated. For his problem, however, these disadvantages did not produce any inconveniences. In the NACA work the problem was the design of an inlet for a supersonic airplane, which requires a large operating range of Mach number and continuity of flow phenomena. The range of Mach number was lower than the range considered by Oswatitsch. An inlet which had all external supersonic compression for the condition of optimum pressure recovery was therefore chosen.

As will be shown in the analysis of this type of inlet, the use of all external supersonic compression gives the following advantages and disadvantages in comparison with the preceding types of inlet:

(a) The inlet with constant geometry can operate with high pressure recovery for a large Mach number range.

(b) The inlet does not present discontinuities of pressure recovery for large variations of mass flow. If the mass flow is decreased, the drag increases more gradually and is less than for the other known types of inlet and the pressure recovery remains high.

(c) The inlet does not have two stable conditions of equilibrium for some range of Mach number.

(d) The inlet is not sensitive to small variations of angle of attack.

(e) The external drag, in general, is larger because a stronger shock must be produced outside. In a supersonic airplane, however, it is possible to use the external compression produced by some parts of the airplane independently of the type of inlet chosen or, in other words, it is possible to locate the inlet in a zone in which the flow is decelerated by the presence of some part of the airplane. In this case the increase in drag due to the external compression of the inlet can be reduced.

## SYMBOLS

x	longitudinal coordinate of cone
R	radius of cone
$x_1$	longitudinal coordinate of cowling
$R_1$	internal radius of cowling
$R_2$	external radius of cowling
M	Mach number
p	pressure
$\theta_c$	angle of cone of central body
$\theta_s$	angle of conical shock
$\theta_l$	cowling-position parameter, angle between axis of inlet and straight line that connects vertex of cone with lip of cowling (see fig. 2)
$C_{De}$	external pressure-drag coefficient
$C_{Da}$	additive-drag coefficient
$\phi$	direction of streamline
Subscripts:	
o	initial stagnation conditions
1	free-stream conditions
2, 3	stations
f	final conditions (stagnation conditions after deceleration into inlet)

## THEORETICAL ANALYSIS

Aerodynamic design of inlet.- An annular circular inlet having a central body was considered for the theoretical analysis. This arrangement was chosen because it could be practically used in front of the fuselage of supersonic airplanes or missiles and because a complete theoretical analysis of the supersonic part of the flow was possible for a circular inlet. For this arrangement an evaluation of the pressure recovery that can be obtained in the supersonic part of the compression and of the external drag of the inlet is possible, and hence a comparison with the other types of inlet can be made.

The frontal type of inlet permits the avoiding or reducing of the interference between shock and boundary layer which usually produces separation, interference which can exist when the inlet is not of the frontal type. Because the aerodynamic principle of this inlet does not necessarily involve the use of a circular body, it must be possible to apply the same principle and obtain similar results with an inlet placed on a noncircular fuselage. The practical design becomes much more complicated, however, because the phenomena cannot be analyzed theoretically at present.

The geometrical arrangement analyzed is shown in figure 2. A central body placed in front of the inlet produces a deceleration of the flow so that the flow at the inlet has a low supersonic or high subsonic speed. The diffuser has a divergent section and therefore the deceleration from supersonic Mach number to subsonic Mach number must occur with a strong shock. When the pressure at the end of the diffuser corresponds to the optimum condition, the strong shock is at the lip of the inlet.

The diffusion losses can be divided into two parts, the losses for decelerating the flow from supersonic to subsonic Mach numbers and the subsonic losses. The supersonic losses depend principally on the losses across the shock waves while the subsonic losses depend on friction and separation. For flight Mach numbers of the order of 1.3 to 2.0 the kinetic energy of the flow at subsonic Mach numbers is an important part of the total kinetic energy of the flow and therefore the subsonic diffuser must be considered in the analysis.

The losses in the supersonic part of the compression depend on the losses across the conical shock and the losses across the strong shock. The conical compression is very efficient because part of the compression behind the conical shock occurs isentropically and because the compression occurs before the boundary layer is formed on the central body; thus the increase of pressure does not affect the boundary-layer thickness. The shock at the entrance is less efficient because it is a strong

shock and tends to produce separation of the boundary layer, thus decreasing the subsonic efficiency. For this reason the conical compression considered is always a large part of the supersonic compression; therefore, large cone angles are considered.

Theoretically it is possible to obtain compression in front of the inlet more gradually and thus to reduce or eliminate the losses of the conical compression. In this case, however, the boundary layer at the surface of the central body undergoes a strong unfavorable pressure gradient, and the central body must be much longer to avoid large external drag and to have the envelope of the compression waves near the lip of the cowl. This condition is necessary to avoid high drag, as will be explained later. The phenomena in the boundary layer corresponding to the strong shock, for the preceding reasons, become more critical and the subsonic efficiency can decrease notably. With a body designed for gradual compression, it also becomes difficult to avoid detached shocks at Mach numbers lower than the design Mach number. For this reason large increases of pressure recovery cannot be expected in the Mach number range considered by using gradual frontal compression and low-drag design. Thus, this type of compression is not considered in this preliminary investigation.

Additive drag.- In order to define the geometry of the inlet, the cone angle and the shape and location of the cowl with respect to the central body must be fixed. For practical calculation of the net thrust of a ram-jet or turbojet vehicle, the thrust given by the engine and the drag due to the engine must be determined; therefore, for efficient operation, the geometry of the inlet must be fixed in such a way as to obtain high pressure recovery and low external drag. For the type of inlet considered the central-body cone angle is the most important parameter affecting the pressure recovery, whereas the value of the drag is strongly affected by the shape and position of the cowl with respect to the central body.

In order to describe consistently the properties of supersonic inlets with external compression only by means of pressure recovery and external-drag coefficient a careful analysis of what must be called "external drag" is required and another drag force must be added to the pressure and viscous drags of the external part of the cowl which, in the original classified version of this paper issued in 1946, was called "additive drag." The definition of this drag and the reason for its inclusion can be obtained from the following considerations.

The <sup>net</sup> thrust due to the engine can be determined by means of the impulse-momentum law applied to the stream tube (fig. 3(a)) entering the inlet between station 1 in the free stream and station 4 at the exit of the inlet. With this definition of thrust, the only value

required in order to take into account the properties of the inlet is the value of the pressure recovery defined as the ratio of the total pressure at the end of the inlet (station 3) to the free-stream total pressure (station 1).

If the thrust is defined differently, as for example, by the impulse-momentum law between the entrance (station 2) and the exit (station 4), the value of the pressure recovery required in order to determine such a value of the thrust would be the pressure recovery between stations 2 and 3. For inlets operating in subsonic flow the pressure recovery between stations 1 and 3 is the same as between stations 2 and 3; whereas for inlets having external compression operating in supersonic flow the pressure recovery between stations 1 and 3 is different from the pressure recovery between station 2 and 3. Therefore, for supersonic inlets the value of the pressure recovery between stations 2 and 3 would not correctly define the inlet characteristics.

Actually, in subsonic flow, the external compression in front of the inlet is isentropic and the pressure recovery between stations 1 and 3, or between stations 2 and 3, is therefore the same. In supersonic flow, however, the two values are different because the compression between stations 1 and 2 occurs with shock waves.

For the supersonic case, because the pressure recovery is usually given by the pressure ratio between stations 1 and 3, which is the only value that correctly describes the properties of the inlet, the definition of external drag consistent with the value of the pressure recovery must be that the drag is the resultant of the pressure along the surface ABC. The surface BC is a physical surface along which the pressure can be measured and the resultant of these pressure forces is a force that is called the pressure drag; the part AB, however, is a streamline which represents a fictitious surface along which the pressure must also be determined. For subsonic flow, the pressure drag along ABCD is zero and all the losses are viscous losses that can be determined by a momentum measured at C; whereas, in supersonic flow, the pressure along AB and along BC are finite because an increase in entropy occurs across shock waves so that the part of the drag along AB must also be considered. This point may be clarified by the following consideration. Consider the streamline ABC (fig. 3(b)) which divides the entering inlet flow from the external flow where B is the entrance of the inlet. In supersonic flow, the compression from A to B (fig. 3(b)) produces a shock wave in the external flow which produces an increase of entropy also in the external flow. Therefore, when the momentum equation is applied to the external flow between sections  $A_\infty$  and  $C_\infty$ , a force is found which represents the resultant of the pressure

along the stream tube denoted by AB and BC and is a function of the entropy increase across the shock waves existing in the flow between  $A_\infty$  and  $C_\infty$ .

The existence of the additive drag can be visualized if the cowling is considered to be extended along stream tube AB. In this case the flow inside and outside the inlet does not change and is similar to the flow for an inlet with internal compression, but the pressure along AB gives a force that corresponds to additive drag. This drag is a function of the difference in diameter between AA and BB and becomes zero when the lip is at points A. In this case the condition of the inlet is analogous to that of the inlet with internal compression and this drag disappears.

The additive drag as a force is found in this case (fig. 2) as the resultant of the pressure forces on the central body. Part of the central-body drag is included in the consideration of pressure recovery and is given by the difference of the force acting along at the surface OD and from the pressure along the surface AB; whereas the force along the surface AB is not included in the value of the pressure recovery.

Additive drag exists in any case in which supersonic external compression which produces shock waves in the external flow occurs. For example, as in the case shown in figure 4, the drag due to the increase in entropy across the strong shock corresponds to the resultant of the pressure force along the stream tube AB and is found as the resultant of the pressure force acting on the body placed inside the channel.

In order to eliminate the additive drag, the size and position of the central body of the inlet must be such that the shock wave OA (fig. 2) is tangent to the cowling at the point B. For this case the additive drag is zero.

For a given central-body cone angle the lip of the cowling can have many positions with respect to the cowling that can be defined by the angle  $\theta_1$ , which is the angle formed by a line from the vertex of the cone to the lip of the cowling and the cone axis. Thus, in order to decrease the additive drag the value of the angle  $\theta_1$  considered for the inlet must be very near to the value of the angle of the conical shock  $\theta_s$  at the maximum Mach number considered.

The external direction of the cowling at the lip must be chosen in such a way as to avoid other external shocks which would increase the external drag. Therefore, the external direction should be as nearly parallel as possible to the free-stream direction for the condition of supersonic flow at the leading edge. Because of the low inlet entering

Mach number, this condition requires that the external direction of the lip of the cowling be very close to the direction of the incoming streamline. The internal part of the cowling must be designed in such a way as to avoid a detached shock at the lip for the Mach number range considered because a detached shock also extends outside of the cowling; therefore, the direction must be approximately tangent to the streamline and the lip of the cowling must be sharp with a minimum possible angle at the edge of the lip.

Flow conditions at different Mach numbers and for different mass-flow conditions.- If the diffuser is designed for the maximum operating Mach number, when the Mach number is reduced the conical shock angle increases and the shock at the lip becomes less intense. Because the length of the streamline between the shock and the lip increases, the additive-drag coefficient increases. The additive internal drag and the maximum pressure recovery that can be obtained for a fixed-geometry inlet and therefore for given values of  $\theta_c$  and  $\theta_l$  can be determined analytically on the basis of cone theory (references 4 and 5). Some results of the calculations are shown in figures 5 to 7. In figure 5 the additive-drag coefficient is calculated for two values of  $\theta_c$  and for different Mach numbers as a function of  $\theta_l$  based on both the cowling entrance area and the free-stream tube area. In figure 6 the values of the angle of the shock as a function of the stream Mach number for different cones is shown.

As is shown in figure 5 the additive-drag coefficient increases if the Mach number decreases from the value of the Mach number corresponding to the design conditions, if the cone angle increases, and if the value of  $\theta_l$  decreases.

The theoretical maximum pressure recovery that can be obtained is shown in figure 7. The values are determined on the assumption that no friction or separation losses exist. For comparison, analogous values determined in reference 1 for an inlet with internal compression are shown. The pressure recovery decreases if the cone angle decreases and decreases slightly if the value of  $\theta_l$  increases (other conditions remaining the same) because the Mach number at the lip of the cowling (points B of fig. 2) increases and therefore the average Mach number at the intake increases. The variation of the supersonic pressure recovery is gradual and for all Mach numbers is higher than the corresponding values for the inlet with internal compression. For Mach numbers of the order of 2 the differences can be of the order of 15 percent.

If the subsonic losses are considered, the value of the pressure recovery must decrease notably. The differences must be larger for higher Mach numbers and for smaller cone angles, because the Mach

number at the surface of the cone increases if the free-stream Mach number increases and if  $\theta_c$  decreases; thus the shock at the entrance becomes stronger and the separation can be more severe. In figure 8 the Mach number on the cone surface is given for different cone angles as a function of the free-stream Mach number. It can be expected that the subsonic losses for the inlet with the central body will be of the same order as the losses for the inlet with internal compression: for the inlet with the central body the wetted surfaces are larger and the subsonic compression is much stronger (beginning with higher Mach numbers) but the shock and the corresponding pressure gradient at the beginning of the subsonic diffuser are much weaker; therefore, differences of the same order as the theoretical values can be expected practically.

As the Mach number changes, the direction of the streamline at the lip of the cowling remains practically constant and therefore no important shocks or expansions occur at the lip when the Mach number changes. Figure 9 shows the direction of the streamline  $\phi$  as a function of  $\theta_l$  for different Mach numbers and cone angles  $\theta_c$ .

When the flight Mach number decreases, the maximum diameter of the free-stream tube which can go into the inlet decreases and the amount of the variation of the diameter increases when the cone angle increases. In the type of inlet with internal supersonic compression the diameter remains constant when the Mach number increases in comparison with the starting Mach number and decreases if the Mach number decreases in comparison with this value. In figure 10 the maximum diameter of the free-stream tube corresponding to the internal flow is given as a function of the free-stream Mach number and the cone angle. The values for the inlet with internal compression are also shown.

The maximum mass flow which enters the inlet with a central body for a given Mach number and altitude cannot be increased without changing the geometry of the inlet, but it can be decreased with less increase of drag than for an inlet with internal compression and without any change of pressure recovery. The variation of the mass flow for the inlet with external compression is similar to that of the inlet with internal compression at lower Mach numbers. If the pressure at the end of the diffuser is increased, the normal shock is pushed outside the inlet and the dimensions of the free-stream tube which enters the inlet decrease. (See fig. 11.) When the strong shock moves outside, the pressure recovery does not change appreciably because the variation of Mach number in front of the shock and therefore the variation of the intensity of the shock is very small. The strong shock also extends outside, but the intensity is small and therefore the variation of

external drag is small and of different order than for the type of inlet with internal compression. If the variation of mass flow occurs at low Mach numbers and the flow at the entrance is subsonic, the variation of the mass flow must cause the shape of the conical shock to change, thus increasing the curvature gradually.

If the angle of attack of the inlet is changed slightly, the pressure recovery and the external drag cannot change appreciably because the conical-flow phenomena are not very sensitive to small variations of angle of attack. The intensity of the shock must increase on the side in which the deviation of the stream produced by the cone increases and must decrease on the opposite side; therefore, the pressure recovery must not change although the external drag must increase slightly.

The pressure drag.- In order to have a complete analysis of the problem, an estimate of the pressure drag of the inlet with external compression must be made. Because the shock produced by the cone is strong, the increase of pressure on the external lip of the cowl is large and therefore gives the impression that the pressure drag must also be very large. In order to make a comparison and to obtain some criteria for designing the external part of the inlet, the pressure distribution was determined for different external lip shapes for values of  $\theta_1$  of  $42^\circ$  and  $46^\circ$  at a Mach number of 1.65 for a  $30^\circ$  cone. The calculations were made by use of the characteristics system described in reference 6.

Because it was necessary to know the length and the maximum diameter of the inlet to determine its external shape, a possible design was made by use of the following data: the Mach number at the maximum section was fixed at 0.24; therefore, the ratio of the maximum diameter to the diameter of the free-stream tube was equal to approximately 1.5 for a Mach number of 1.65. The length of the cowl was determined on the basis of the internal diffusion and was fixed at a value of the order of 3 diameters. For comparison an inlet with internal compression and with the same design conditions was analyzed. For every angle  $\theta_1$  two external shapes were designed. (See fig. 12.) All external shapes for the inlet with external compression have the same direction as the streamline at the lip of the cowl, but the first cowl changes direction gradually near the lip and then changes direction rapidly and becomes tangent to the cylinder while the second has a strong variation of direction (corresponding to the maximum possible practically) near the lip which continues more gradually until the cowl becomes tangent to the cylinder at a distance of approximately 1.5 inlet diameters.

The two designs were fixed on the basis of the following aerodynamic criteria. The streamline reached the lip of the cowling with high pressure and low velocity and made an angle with the free-stream velocity. If it were possible to produce a deviation of expansion at the lip equal to the difference in direction between the free-stream direction and the direction of the flow at the lip, the pressure would decrease abruptly and become less than free-stream pressure because the expansion would occur locally with the two-dimensional law. In this case the pressure along the cowling would later increase again but the value would remain low and therefore the pressure drag of the body would be very low. Accordingly the first external shape was designed with the idea of producing the maximum possible practical expansion of the flow in such a way as to reduce the pressure to a low value on the external part of the cowling. The second shape was designed to have less expansion near the lip and larger expansion farther back and the pressure was calculated in order to determine the difference in drag in the importance of producing a large expansion near the lip. The ordinates for the four cowling shapes considered are given in table I.

The results of the calculations are summarized in the following table in which some values for a Mach number of 2.00 are also indicated. The data for Mach number 2.00 have been obtained less exactly than the values for Mach number 1.65 but the results have sufficient accuracy for the analysis. The external drag coefficients are referred to the cowling entrance area.

Inlet with external compression		
$\theta_c = 30^\circ, M = 1.65$		
Shape	$C_{D_e}$	
	$\theta_l = 46^\circ$	$\theta_l = 42^\circ$
1	0.064	0.042
2	.141	.133
$\theta_c = 30^\circ, M = 2.00$		
1	0.0562	0.0404
Inlet with internal compression (having $4^\circ$ inclination)		
Mach number	$C_{D_e}$	
1.65	0.076	
2.00	.064	

As is shown in the table, the values of the pressure drag can change appreciably with the external shape. The values of the pressure-drag coefficient change slightly when the value of  $\theta_1$  changes (the frontal area of the cowling increases for the same mass flow when the values of  $\theta_1$  increases) but the drag remains small and is of the same order of magnitude as for the other type of inlet if the design is correct. The variations of pressure drag corresponding to the variation of  $\theta_1$  are much smaller than the corresponding variations of the additive-drag coefficient.

For the inlets with external compression it is necessary to add to the pressure drag, the additive drag, which is given in the following table:

Mach number	$C_{D_e}$ (referred to cowling entrance area)			
	$\theta_1 = 42^\circ$	$\theta_1 = 46^\circ$	$\theta_1 = 47.5^\circ$	$\theta_1 = 56.3^\circ$
1.65	0.190	0.112	-----	0
2.00	.091	.195	0	-----

As is shown in this table, the additive drag is very important; therefore, it is necessary to choose the value of  $\theta_1$ , on the basis of the maximum flight Mach number, very near to the value of  $\theta_g$ .

The preceding considerations show that for every Mach number there exists a value of  $\theta_1$  equal to the value of  $\theta_g$  for which the additive-drag coefficient is zero. It is evident, therefore, that the value of the additive drag can be decreased notably at Mach numbers lower than the design Mach number without changing the value of the pressure recovery if an inlet is used that permits some variation of the value of  $\theta_1$  by moving the position of the central body.

#### TEST RESULTS

Because the theoretical analysis has shown that very high pressure recovery must be expected with the arrangement considered, an experimental investigation was made to check the results of the calculations. The tests were made in an intermittent jet used for tests of compressor cascade blades at subsonic Mach numbers, which was transformed for these tests into a supersonic jet. The necessity of changes and the scarce air supply that was used simultaneously for other experimental installations caused a very long period of testing to be required; therefore, the tests were concluded long after the theoretical analysis was finished.

### Apparatus and Methods

In order to investigate experimentally the properties of diffusers with external supersonic compression, three models were designed for tests in the modified 4-inch cascade tunnel. The cascade tunnel was modified in such a way as to permit supersonic tests, and two-dimensional supersonic nozzles were constructed for obtaining parallel flow in the test chamber. The nozzles were made of wood; the surfaces therefore had a degree of roughness and some waves were produced from the small wrinkles and porosity on the nozzle surfaces. These waves were of small intensity and therefore were not considered to have any effect on the aerodynamic phenomena of the inlets. The dimensions of the test chamber were about constant for all Mach numbers and were of the order of 4 by 5 inches. The air supply was obtained from a high pressure tank which permitted the obtaining of relatively dry air and, therefore, condensation effects were not important.

Tests were made at Mach numbers of 1.33, 1.52, 1.72, and 2.10, and a different system of tests was used for the different Mach numbers. For a Mach number of 1.33 a completely open jet was used and the test-chamber pressure was made larger than atmospheric pressure to avoid choking effects. For tests at the higher Mach numbers diffusers of different shapes were used to avoid large pressure ratios for the start of supersonic flow. Figure 13 shows schematic sketches of the installation.

The models tested had 2-inch diameters at the cylindrical part and the Reynolds number of the tests (referred to the outside diameter) was of the order of  $3.5 \times 10^6$  for a Mach number of 2.10 and increased to  $4.5 \times 10^6$  for a Mach number of 1.33. All the models were designed in such a way as to maintain the same subsonic diffuser shape in order to avoid the introduction of another parameter in the analysis, and therefore the models were made with interchangeable cones and cowlings for changing the geometry of the supersonic part of the inlet. The supersonic part was designed so that the same flow conditions were maintained in the subsonic diffuser for the same test Mach number while the same model was used for the subsonic diffuser and the mass-flow variation system. (See fig. 14.)

The aerodynamic parameters considered for the model designs are shown in figure 15, in which a small shock is designed on the outside of the lip. The shock is produced by the lip that was placed at an angle with respect to the streamline in the tests, as will be explained later. In a large-scale model this shock can probably be eliminated because the lip can be constructed with a smaller angle than the model; therefore, the corresponding drag can be eliminated in full-scale models. The shock exists in the models tested, however, and can be seen in the schlieren photographs. (See fig. 16.)

The internal part of the diffuser was designed to have a gradual increase in section from the lip of the cowling to the end of the diffuser. The divergency of the stream tube increased at the end of the diffuser and was practically zero at the lip of the cowling. The long throat at the minimum section was included to reduce the separation due to the strong shock and to decrease the effect of disturbances produced in the subsonic part, as is shown by Kantrowitz of the Langley Laboratory of the NACA. The average angle of divergency of the stream tube is  $8^\circ$  (total).

For every model and for every Mach number different tests were made with different values of back pressure. The back pressure was varied by moving the position of a plug at the exit of the diffuser (fig. 14). Several combinations of cones and cowlings were tested. The models were designed with the following geometrical parameters. The first model had a  $30^\circ$  cone angle and  $\theta_1$  was  $42^\circ$  (cone I, cowling I). The second model had the same cone angle but  $\theta_1$  was  $46^\circ$  (cone II, cowling II). The third model had a  $25^\circ$  cone angle and  $\theta_1$  was chosen to correspond to the inclination of the shock for the  $25^\circ$  cone for the same Mach number (2.60) for which the shock is inclined  $42^\circ$  for the  $30^\circ$  cone; the angle  $\theta_1$  was  $36.5^\circ$  (cone III, cowling III).

The cowlings for these three combinations must be designed theoretically to have the direction of the lips parallel to the streamlines. Because small-scale models were used, it was not possible to keep the angle of the cowling near the lip as small as is desired and as must be the case for a full-scale model. The angle was therefore placed half outside and half inside the theoretical direction of the stream on the assumption that the compression outside can be avoided in a full-scale model. The external inclinations of cowlings I, II, and III were  $21^\circ$ ,  $19^\circ$ , and  $17.2^\circ$ , respectively, and the internal inclinations were  $19^\circ$ ,  $17^\circ$ , and  $15.2^\circ$ , respectively. Cowling III, designed for the  $25^\circ$  cone model, was also tested with cone I, and cowling II was tested with cone I to determine the sensitivity of the phenomena to small variations of geometrical parameters.

Because no drag measurements were made, the external shape of the cowling was designed in accordance with aerodynamic criteria near the lip only, while in the back part only constructional criteria were considered.

## Results and Discussion

The values of the pressure recovery obtained for the optimum conditions (conditions of strong shock at the lip of the inlet) are shown in figure 17 for the different models tested. In figure 18 the efficiency of the inlet is shown. This efficiency is defined by equation (1) of reference 1 as

$$\eta = 1 - \frac{5}{M_1^2} \left[ \left( \frac{p_0}{p_f} \right)^{1/3.5} - 1 \right] \quad (1)$$

For comparison the maximum pressure recovery and efficiency obtained experimentally for a type of inlet with internal compression as a function of the free-stream Mach number are also shown.

The variation of the pressure recovery obtained when the mass flow entering the inlet decreases is shown in figure 19. In this figure the pressure recovery is plotted as a function of the ratio of the mass flow considered to the maximum mass flow possible, a ratio which is called the relative mass flow.

In figure 16 some schlieren photographs for different conditions of mass flow into the inlet are shown. The schlieren photographs show that when the mass flow decreases the phenomena change gradually and steadily. The tests were made with the shock far from the lip.

The test results confirm the theoretical predictions and show that with an inlet with a central body higher pressure recoveries can be obtained than with an inlet with internal compression. The tests also show that for a given cone angle and for a given Mach number the pressure recovery changes very slightly if the value of  $\theta_l$  changes. It is therefore possible to obtain very high pressure recovery for the flight conditions considered, as found in the tests, and low drag if the inlet is designed for the Mach number considered with a value of  $\theta_l$  very near to the value of  $\theta_s$  to eliminate the additive internal drag. In this case the advantage of external compression in increasing the pressure recovery is not reduced by a large increase in drag.

Schlieren photographs show that when the mass flow is reduced the strong shock goes outside of the intake and moves forward in the direction of the conical shock. The conical shock becomes curved, thus showing that the external drag increases but the variation is gradual. For the low Mach numbers, when the flow behind the conical shock becomes subsonic, the variation of the mass flow changes the shape of the conical shock which becomes curved.

The efficiency of the inlet with external compression is very high and therefore a large increase in the value of the thrust coefficient will be obtained using this type of inlet, if the inlet is designed so as to reduce the drag to a minimum.

### CONCLUSIONS

A new type of inlet with all the supersonic part of the deceleration outside of the diffuser is analyzed theoretically, and it is shown that this arrangement permits higher pressure recovery than an inlet with internal compression. It is shown also that the external supersonic compression can eliminate or reduce all the discontinuities of flow characteristics which exist for a type of inlet with internal compression when the flight Mach number or the mass flow decreases from the values fixed by the design conditions. The maximum mass-flow variation as a function of the free-stream Mach number is larger than for the inlet with internal compression and the law of variation is dependent on the angle of the central cone. A design criterion is given for reducing to a minimum the value of the drag produced by the external supersonic compression which can be high for some flight conditions.

Experimental results confirm the values of the theoretical analysis and show that it is possible to obtain pressure recoveries of the order of 95 percent for Mach numbers from 1.33 to 1.52, 92 percent for a Mach number of the order of 1.72, and 86 percent for a Mach number of the order of 2.10, values which are much higher than the corresponding values that can be obtained with an inlet with internal compression.

Langley Aeronautical Laboratory  
National Advisory Committee for Aeronautics  
Langley Field, Va., November 14, 1946

## REFERENCES

1. Kantrowitz, Arthur, and Donaldson, Coleman duP.: Preliminary Investigation of Supersonic Diffusers. NACA ACR L5D20, 1945.
2. Oswatitsch, Kl.: Pressure Recovery for Missiles with Reaction Propulsion at High Supersonic Speeds (The Efficiency of Shock Diffusers). NACA TM 1140, 1947.
3. Oswatitsch, Kl., and Böhm, H.: Luftkräfte und Strömungsvorgänge bei angetriebenen Geschossen. Berichte Nr. 1010 and 1010/2, Forsch. und Entwickl. des Heereswaffenamtes (Göttingen), 1944.
4. Buseman, A.: Drücke auf kegelförmige Spitzen bei Bewegung mit Überschallgeschwindigkeit. Z.f.a.M.M., Bd. 9, Heft 6, Dec. 1929, pp. 496-498.
5. Taylor, G. I., and Maccoll, J. W.: The Air Pressure on a Cone Moving at High Speeds. Proc. Roy. Soc. (London), ser. A, vol. 139, no. 838, Feb. 1, 1933, pp. 278-311.
6. Ferri, Antonio: Application of the Method of Characteristics to Supersonic Rotational Flow. NACA Rep. 841, 1946.

TABLE 1.- EXTERNAL COWLING COORDINATES

$\theta_2 = 42^\circ$				$\theta_2 = 46^\circ$			
Shape 1		Shape 2		Shape 1		Shape 2	
$x_1$	$R_2$	$x_1$	$R_2$	$x_1$	$R_2$	$x_1$	$R_2$
0	1.000	0	1.00	0	1.00	0	1.000
.05	1.013	.05	1.020	.05	1.015	.05	1.015
.10	1.025	.10	1.037	.10	1.032	.10	1.032
.15	1.035	.15	1.053	.15	1.047	.15	1.047
.20	1.045	.20	1.070	.20	1.063	.20	1.063
.25	1.053	.25	1.088	.30	1.087	.30	1.090
.30	1.061	.30	1.100	.40	1.104	.40	1.115
.40	1.076	.40	1.125	.50	1.122	.50	1.136
.50	1.092	.50	1.148	.60	1.138	.60	1.155
.60	1.104	.60	1.170	.70	1.150	.70	1.173
.70	1.117	.70	1.190	.80	1.162	.80	1.189
.80	1.130	.80	1.207	.90	1.174	.90	1.206
.90	1.143	.90	1.224	1.00	1.186	1.00	1.221
1.00	1.157	1.00	1.242	1.10	1.198	1.10	1.235
1.10	1.169	1.10	1.259	1.20	1.207	1.20	1.248
1.20	1.182	1.20	1.273	1.30	1.216	1.30	1.259
1.30	1.193	1.30	1.282	1.40	1.228	1.40	1.271
1.40	1.205	1.40	1.288	1.50	1.238	1.50	1.282
1.50	1.215	1.50	1.293	1.60	1.250	1.60	1.292
1.60	1.227	1.60	1.298	1.70	1.260	1.70	1.302
1.70	1.238	6.00	1.298	1.80	1.272	1.80	1.312
1.80	1.248			1.90	1.282	1.90	1.321
1.90	1.258			2.00	1.293	2.00	1.330
2.00	1.267			2.10	1.304	2.10	1.338
2.10	1.274			2.20	1.315	2.20	1.347
2.20	1.282			2.30	1.326	2.30	1.355
2.30	1.288			2.40	1.338	2.40	1.362
2.40	1.293			2.50	1.348	2.50	1.370
2.50	1.295			2.60	1.357	2.60	1.377
2.60	1.298			2.70	1.363	2.70	1.382
6.00	1.298			2.80	1.368	2.80	1.385
				2.90	1.373	2.90	1.386
				3.00	1.377	3.00	1.388
				3.10	1.380	3.10	1.388
				3.20	1.383	3.20	1.388
				3.30	1.385	3.30	1.388
				3.40	1.387	3.40	1.388
				3.50	1.390	3.50	1.389
				6.00	1.390	3.60	1.390
						6.00	1.390



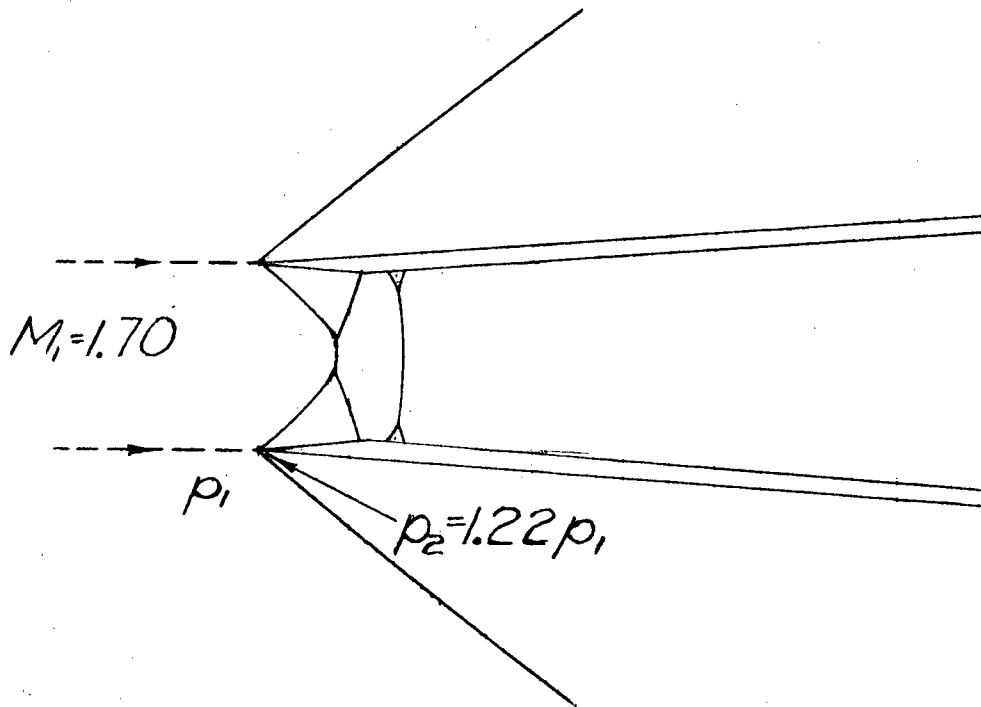

(a) Mass flow corresponding to design condition.

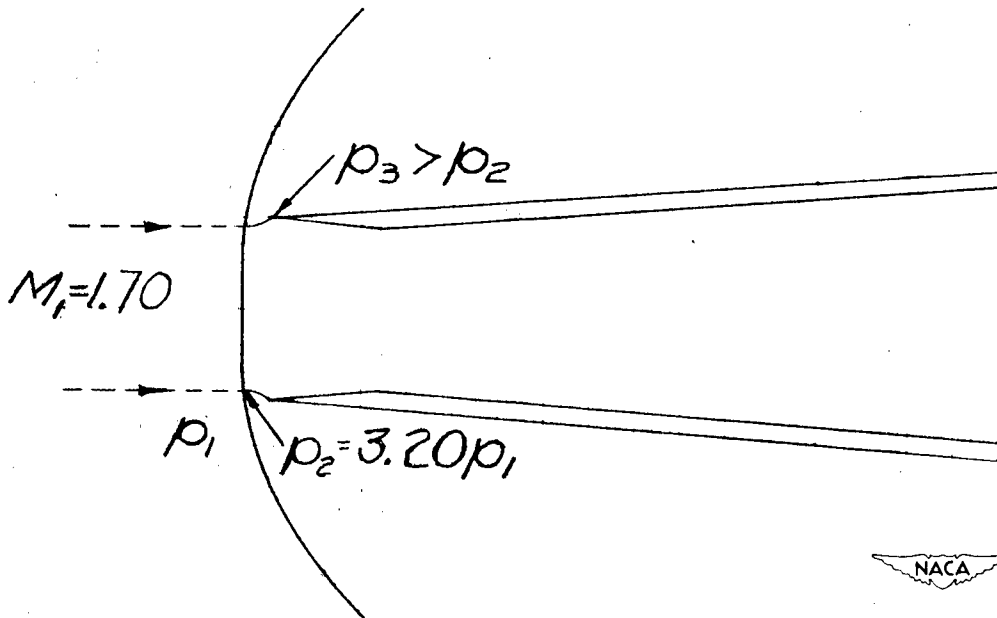

(b) Mass flow lower than value for design condition.

Figure 1.- Schematic diagram of aerodynamic phenomena for an inlet with all internal compression with different mass-flow conditions for  $M_1 = 1.7$ .

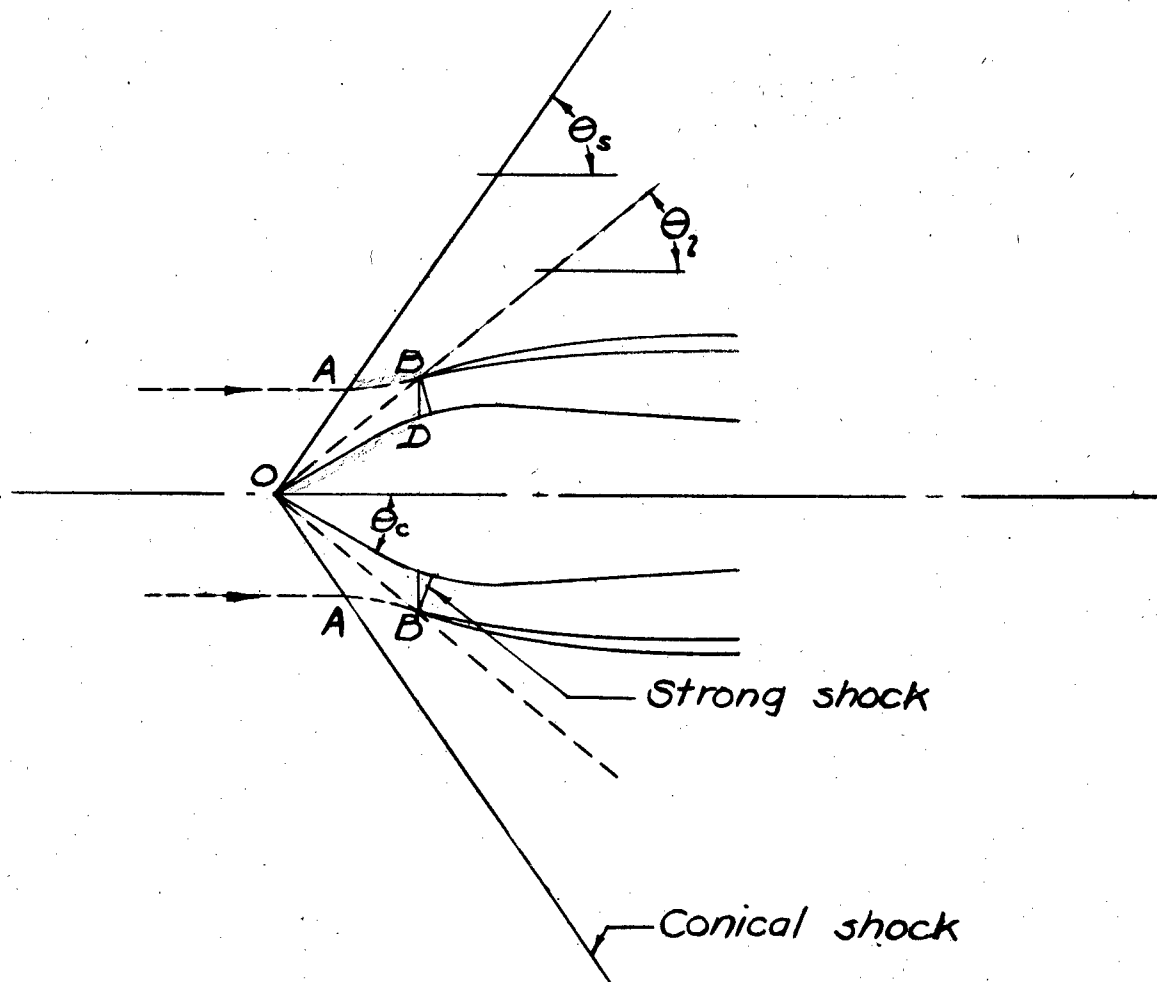
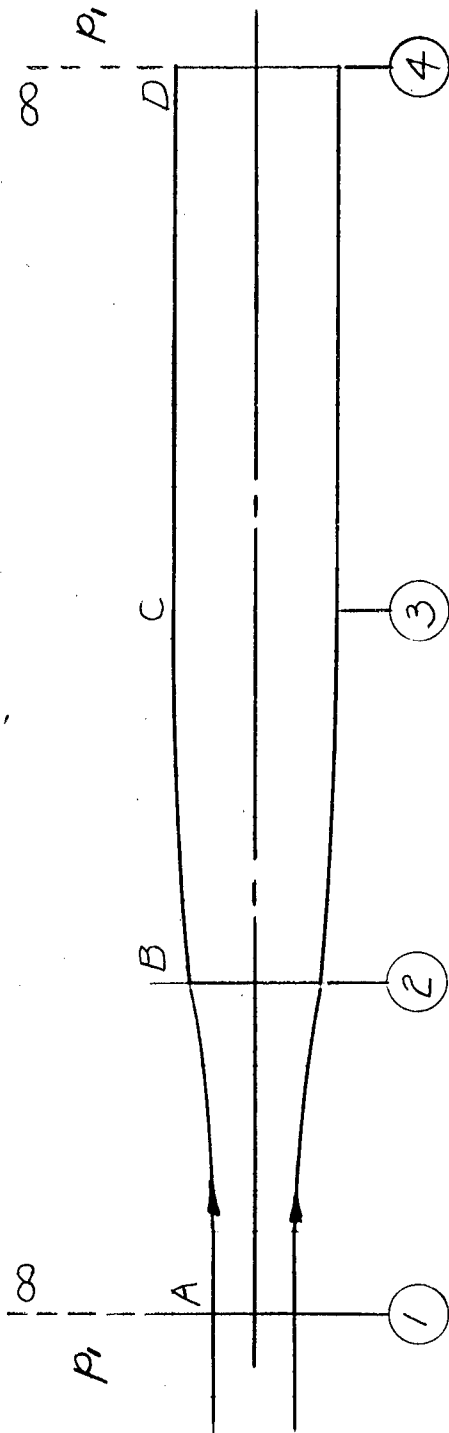
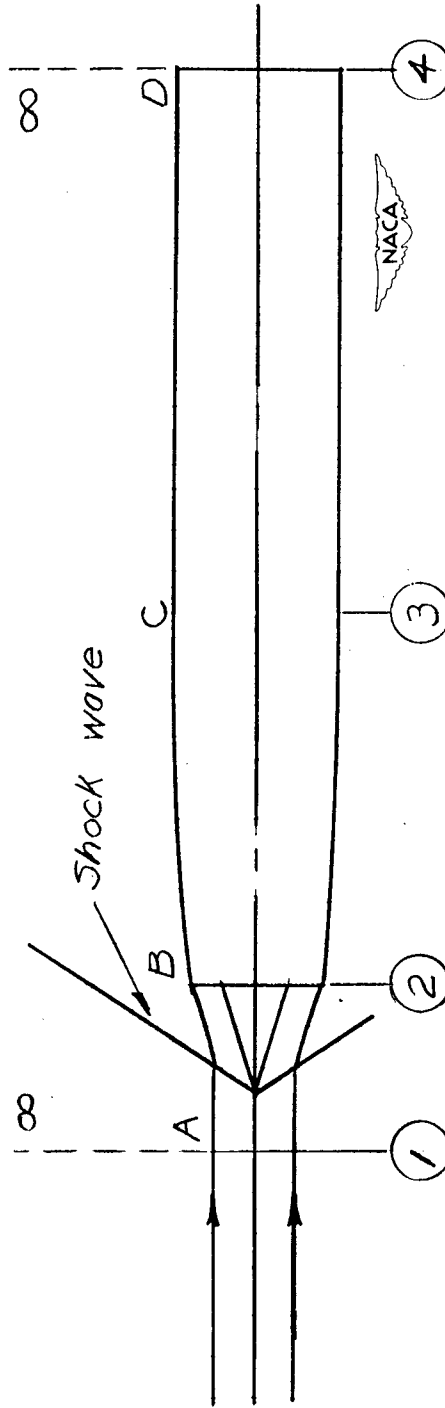

Figure 2.- Arrangement of the inlet considered.



(a) Subsonic free-stream Mach number.



(b) Supersonic free-stream Mach number.

Figure 3.- Schematic representation of flow around inlets.

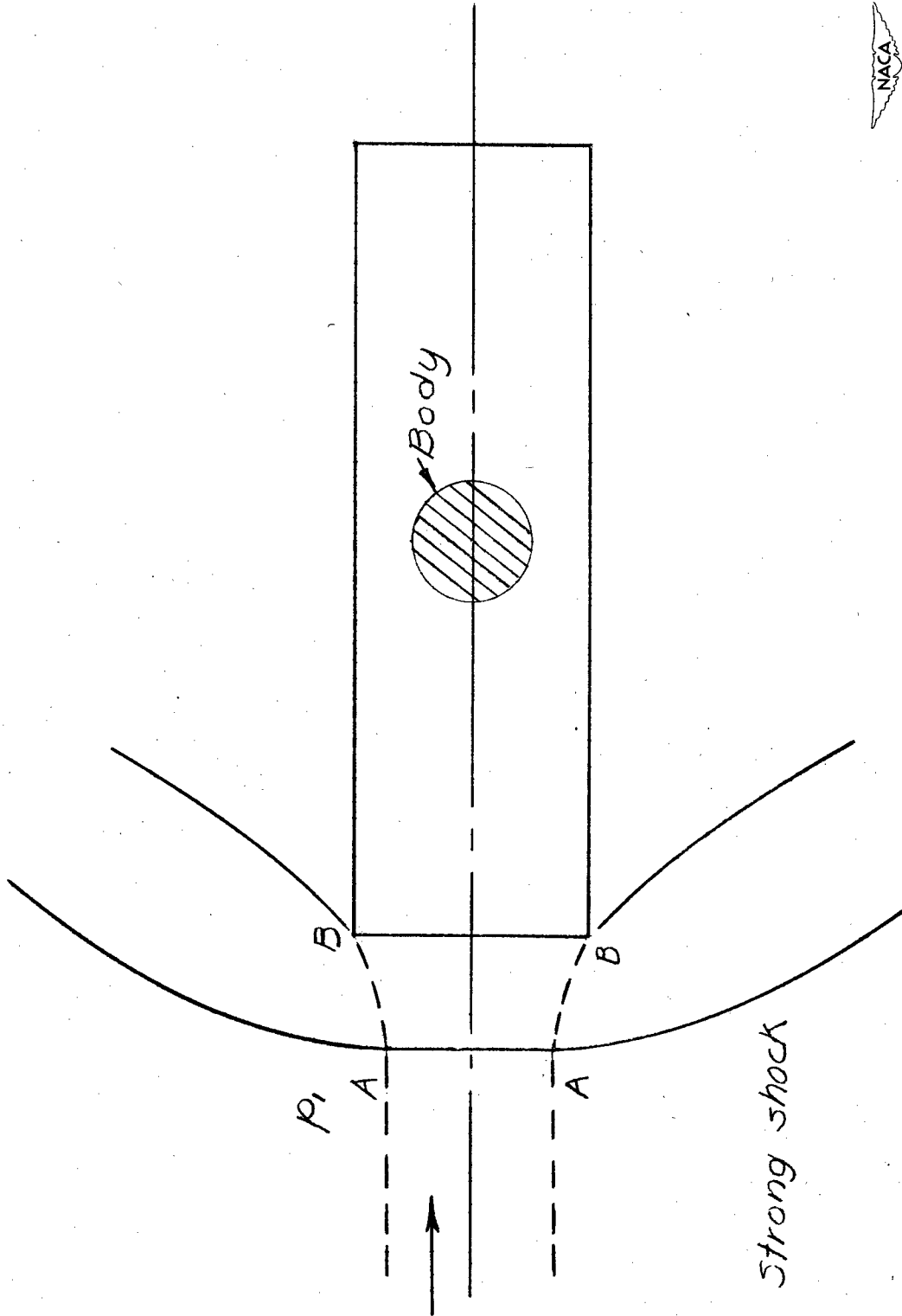

Figure 4.- Schematic representation of drag corresponding to increase in entropy.

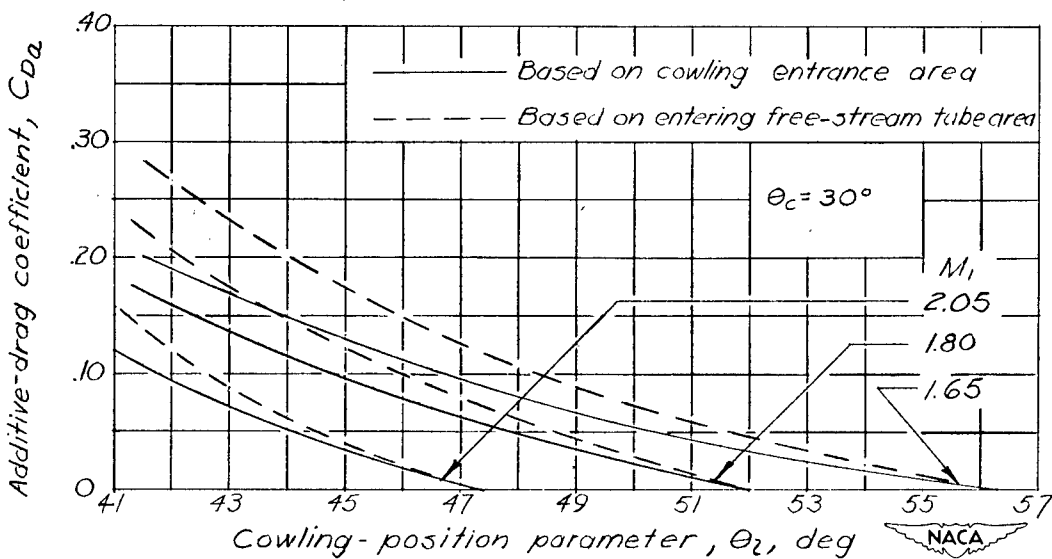
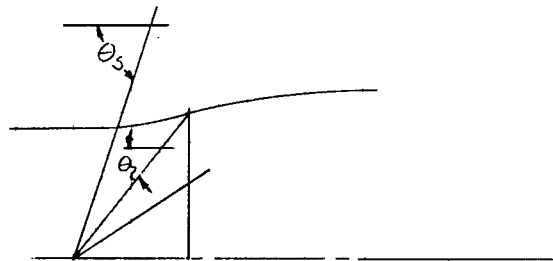
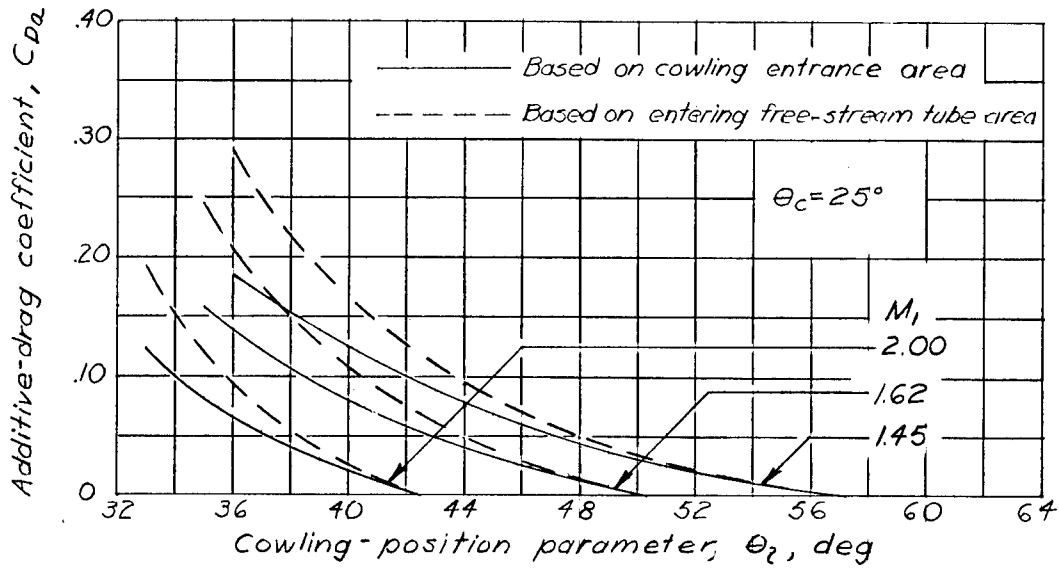

Figure 5.- Additive-drag coefficient as a function of cowling-position parameter.

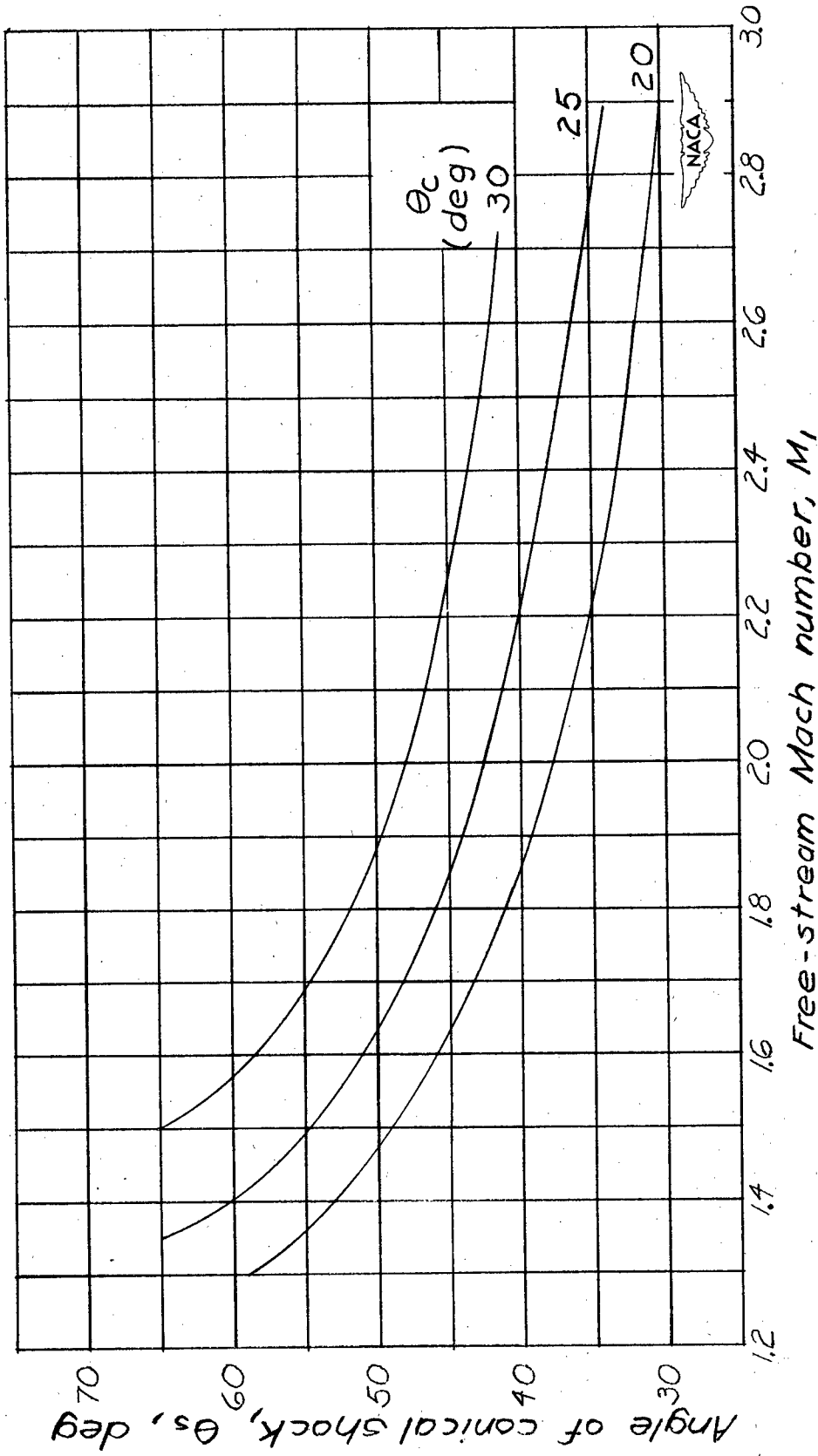

Figure 6.- Angle of conical shock as a function of the free-stream Mach number.

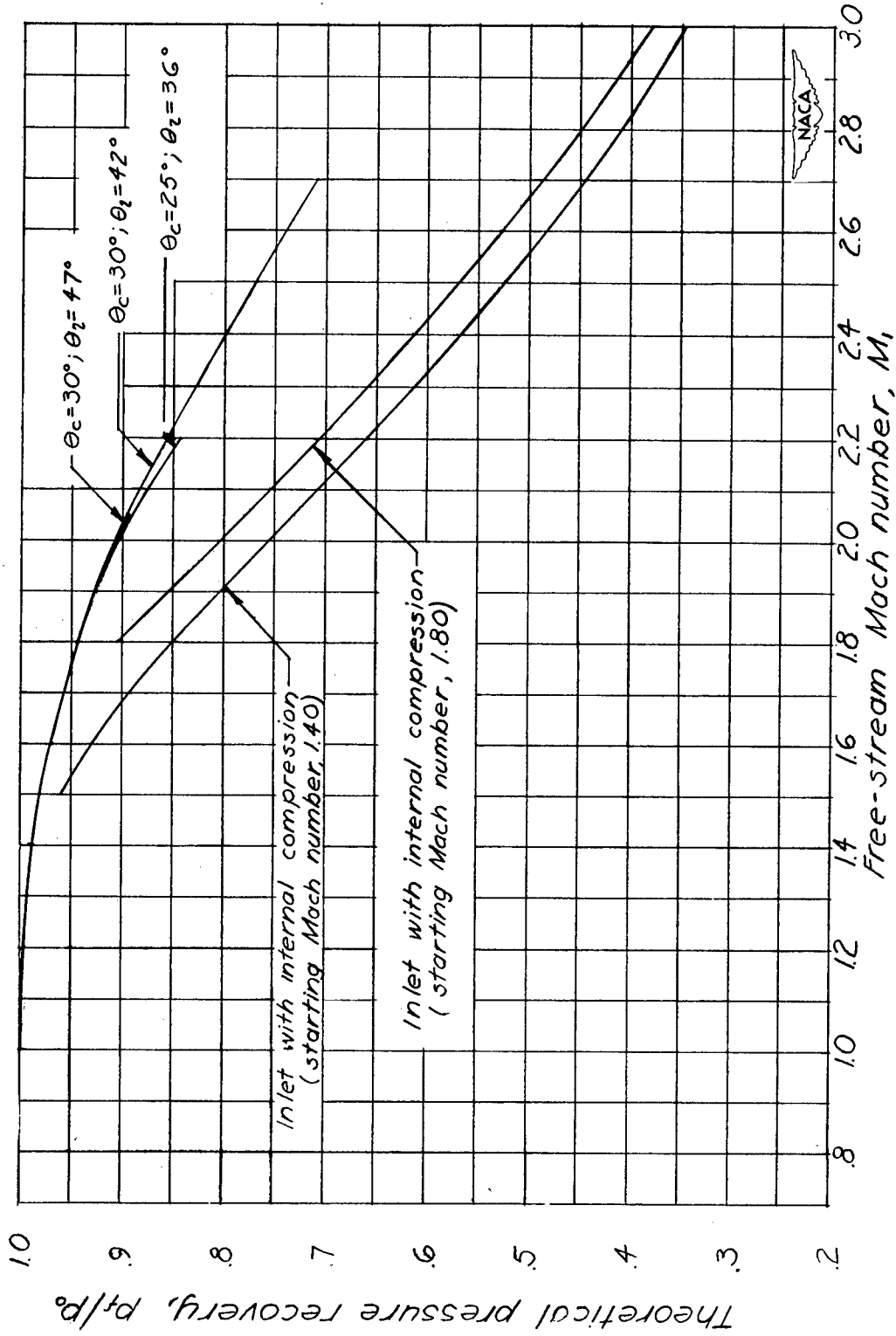

Figure 7.- Theoretical supersonic pressure recovery as a function of the free-stream Mach number. (Curves for inlet with internal compression from reference 1.)

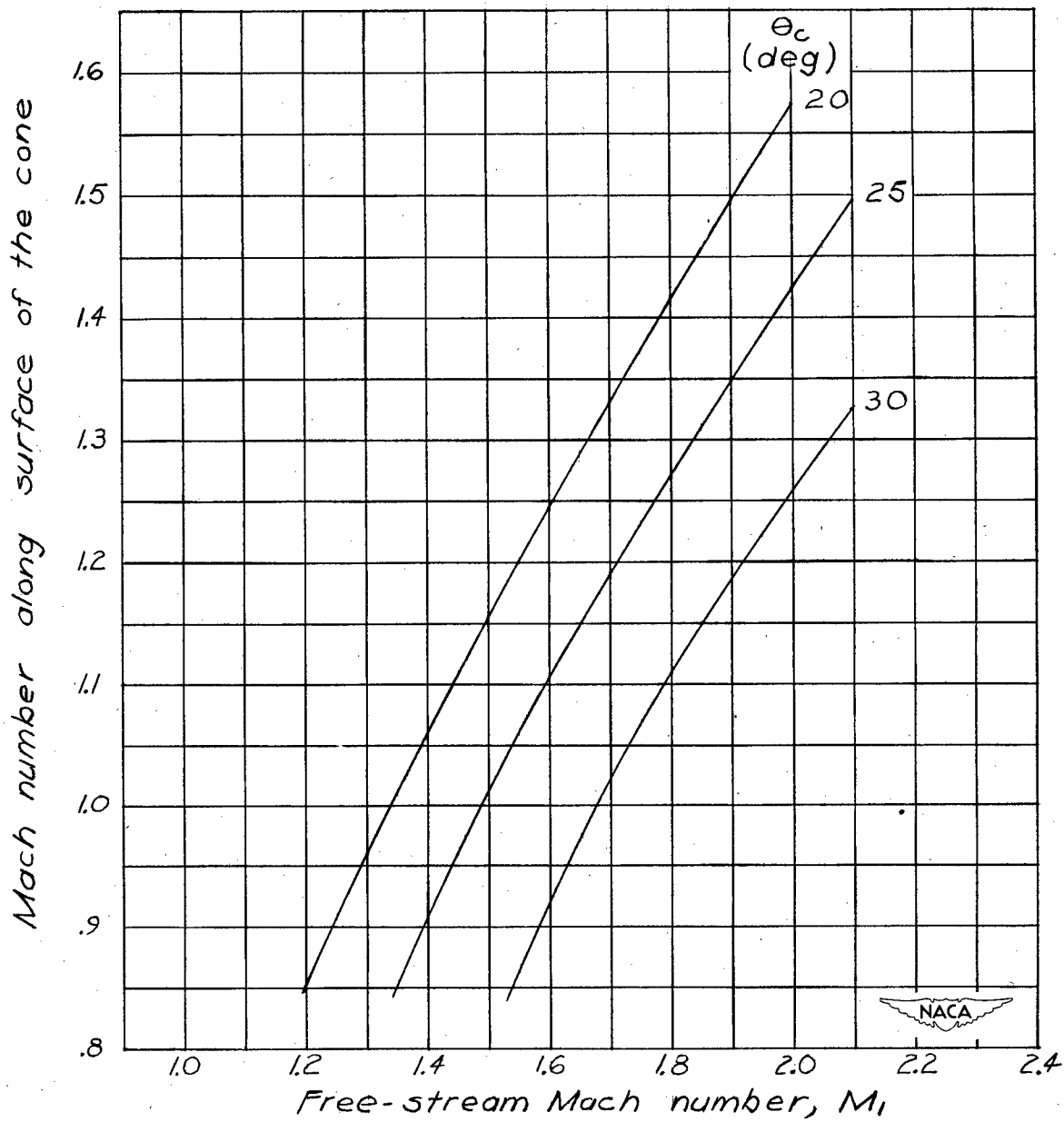

Figure 8.- Mach number along surface of the cone as a function of the free-stream Mach number.

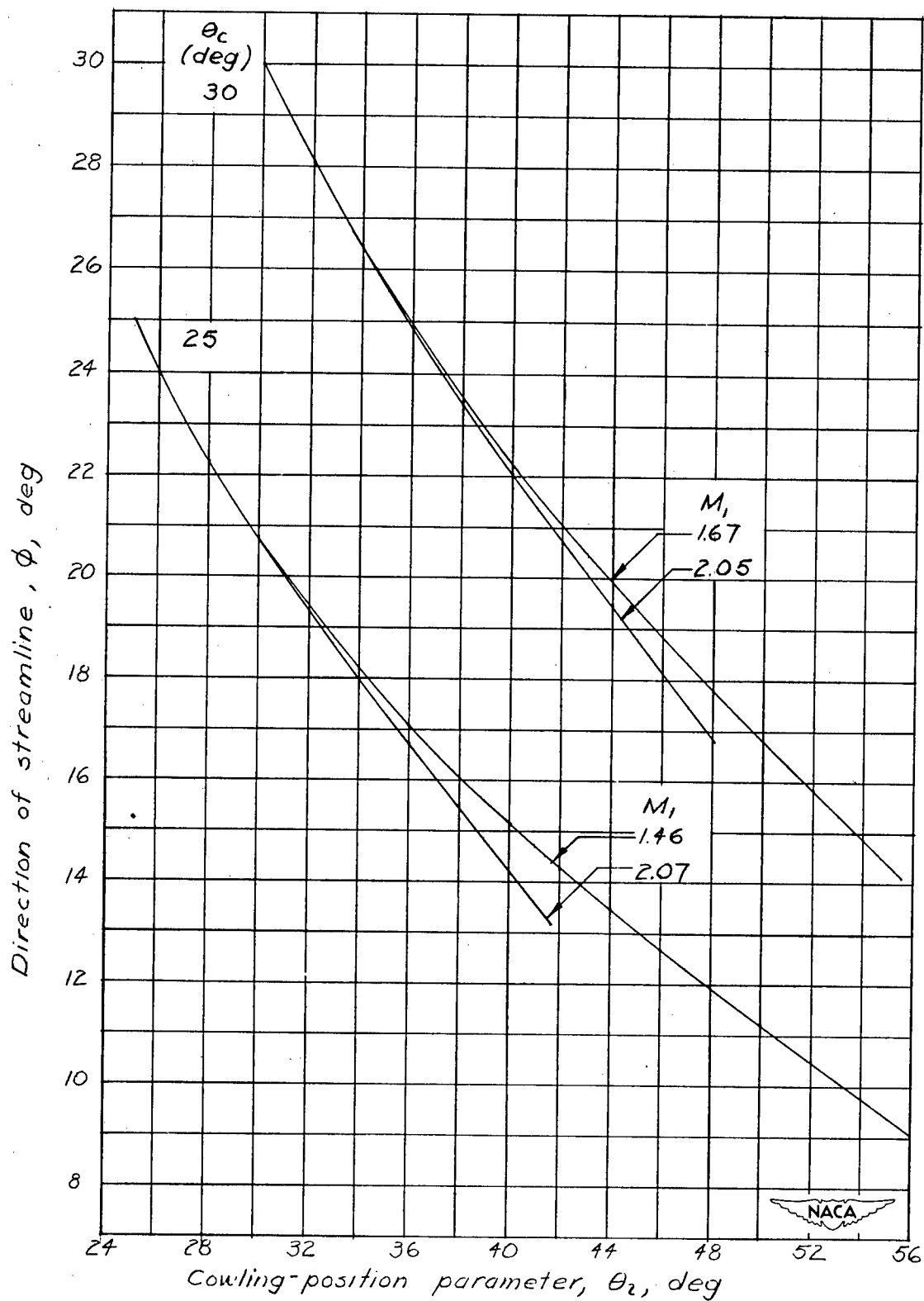

Figure 9.- Direction of the streamline for different Mach numbers and cone angles as a function of cowling-position parameter.

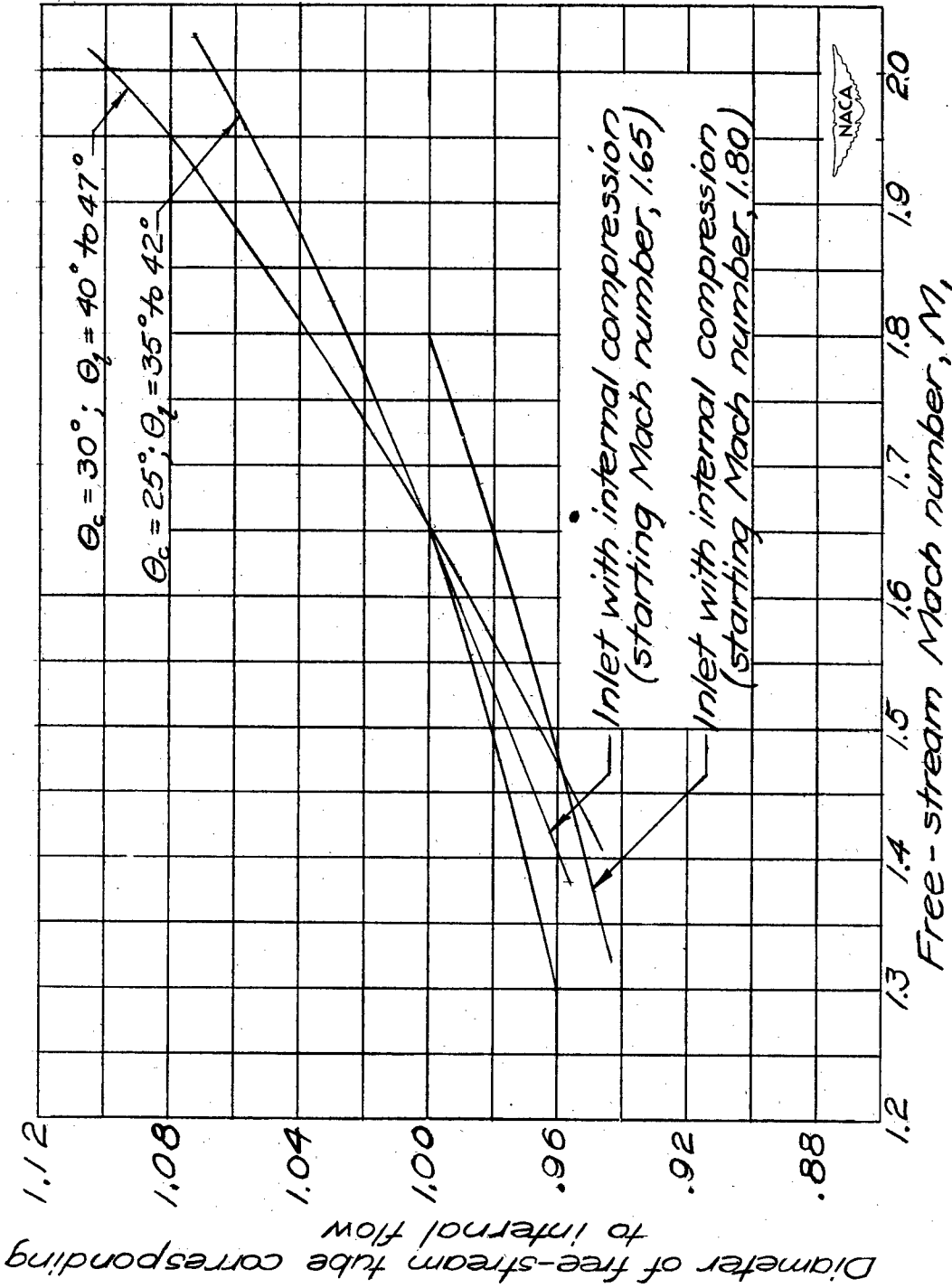

Figure 10.- Diameter of the free-stream tube of the internal flow as a function of the free-stream Mach number.

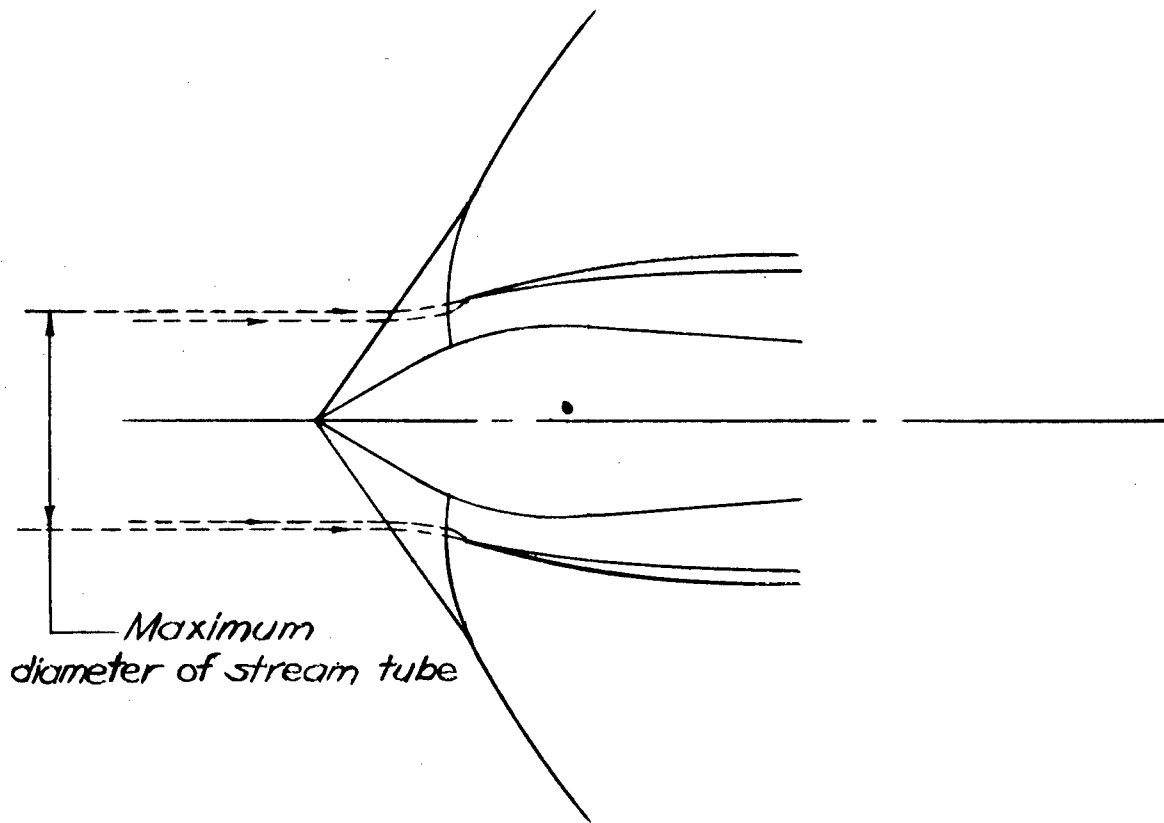

Figure 11.- Schematic diagram of the flow when the mass flow into the inlet is reduced.

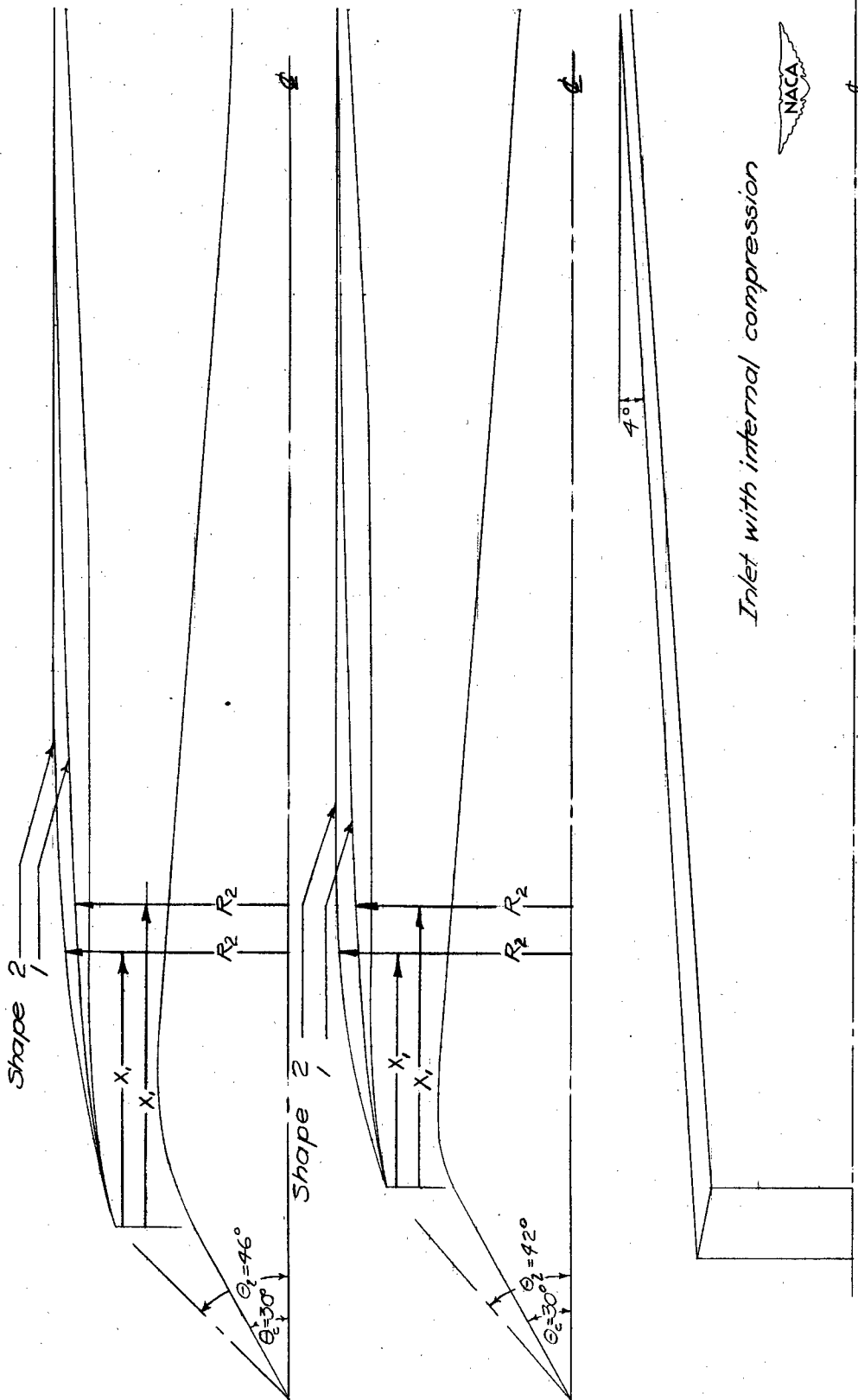
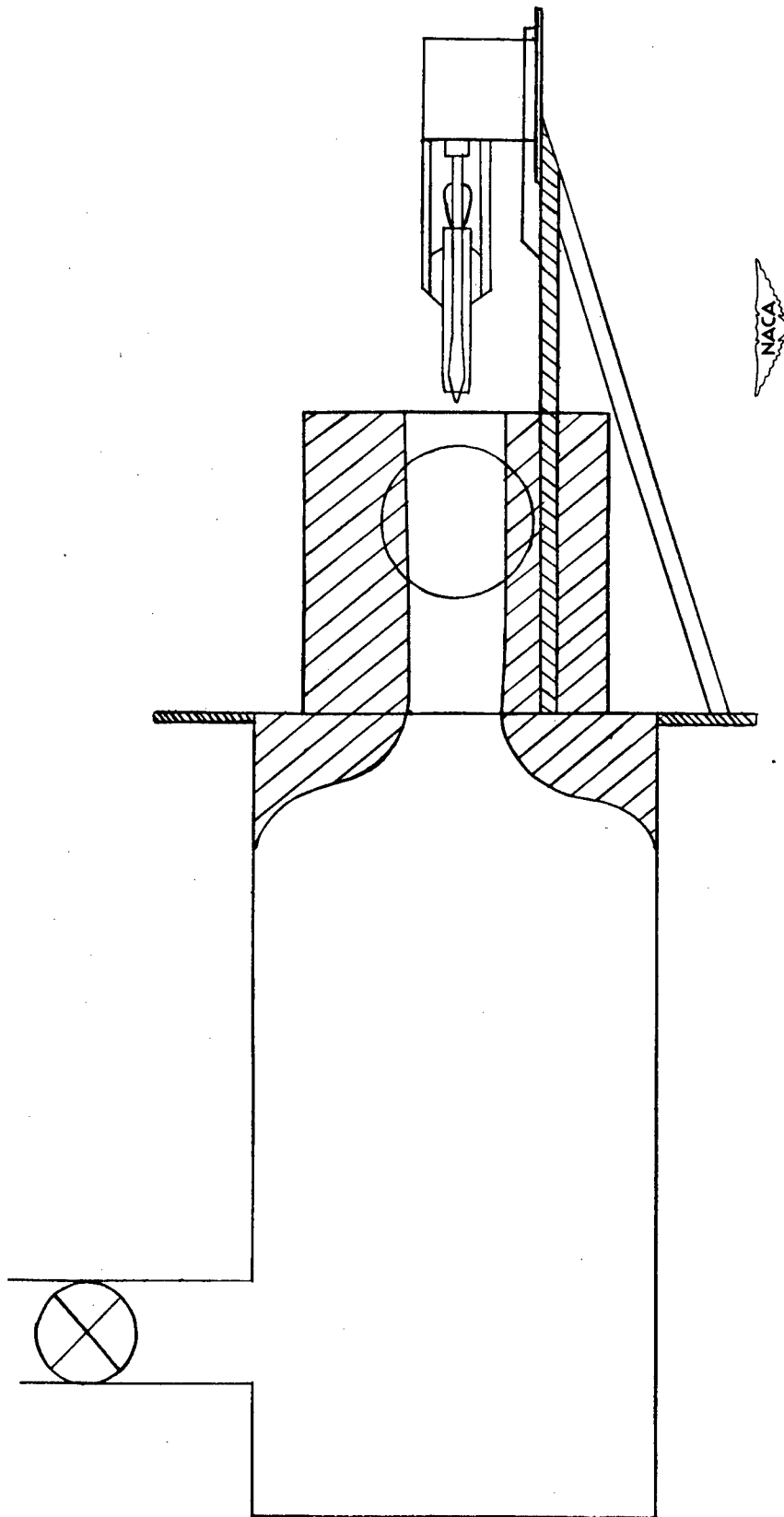
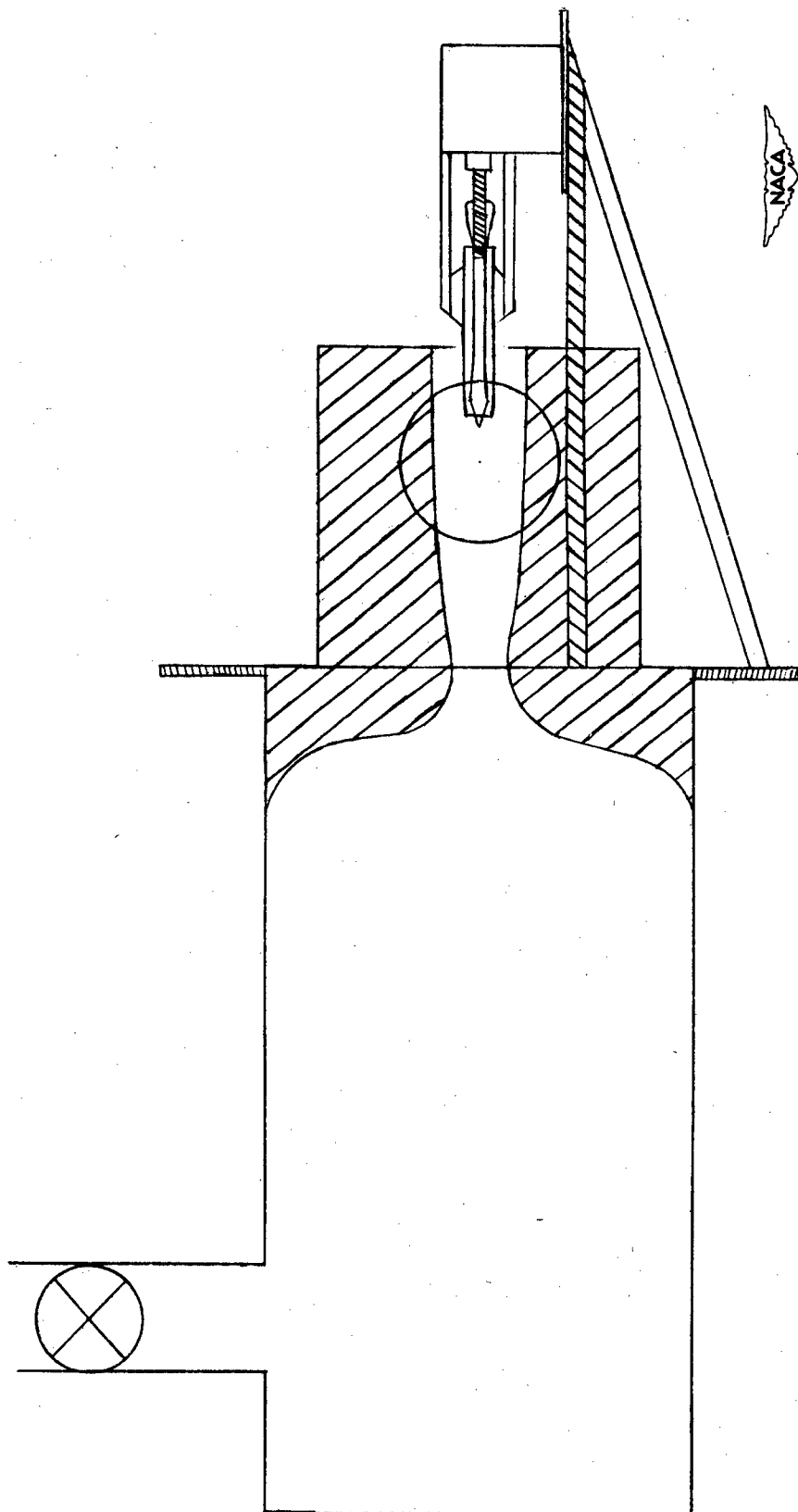

Figure 12.- The external shapes of the inlets with external compression and the inlet with internal compression used to determine the pressure drag.



(a)  $M_1 = 1.33$ .

Figure 13.- Design of the installation.



(b)  $M_1 = 1.52, 1.72, \text{ and } 2.10.$

Figure 13.- Concluded.

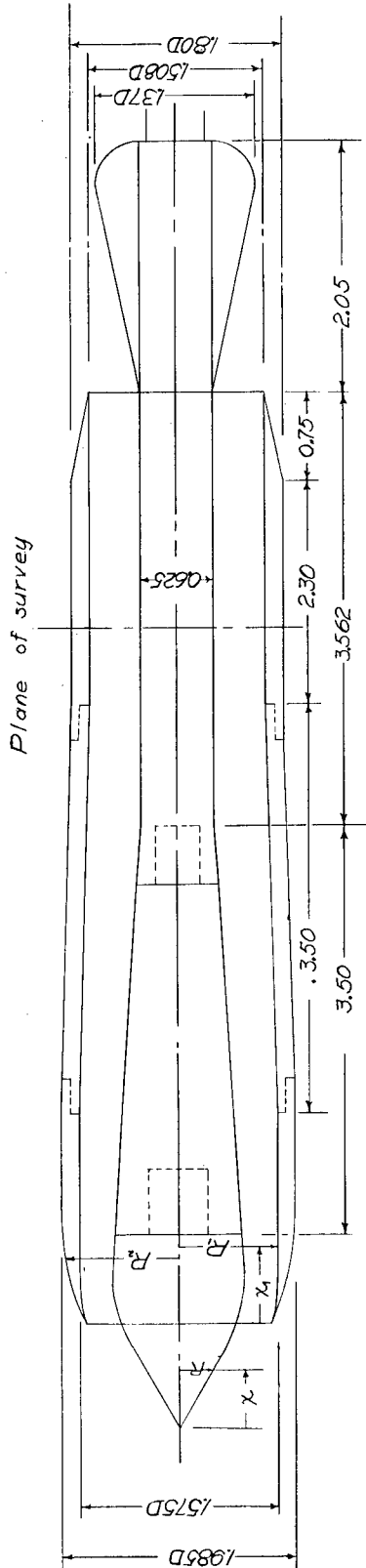

*Ordinates of cones and cowlings*

Cone I		Cone II		Cone III		Cowling I		Cowling II		Cowling III	
$x$	$R$	$x$	$R$	$x$	$R$	$x$	$R$	$x$	$R$	$x$	$R$
0	0	0	0	0	0	0	0	0	0	0	0
.25	.144	.25	.144	.250	.117	.1	.812	.250	.788	.100	.817
.50	.288	.50	.288	.500	.233	.2	.828	.500	.823	.200	.834
.75	.433	.75	.420	.750	.350	.3	.837	.750	.840	.300	.842
1.00	.529	1.00	.501	1.000	.466	.4	.842	1.000	.846	.372	.846
1.25	.564	1.25	.540	1.250	.550	.6	.846	.969	.846	.550	.846
1.50	.549	1.50	.546	1.500	.561	.8	.846	.987	.846	.750	.846
1.65	.539	1.65	.539	1.750	.548	1.0	.846	.992	.846	.950	.846
				1.875	.539	1.2	.846	.992	.846	.992	.846

Figure 14.- The models tested. (All dimensions are in inches.)

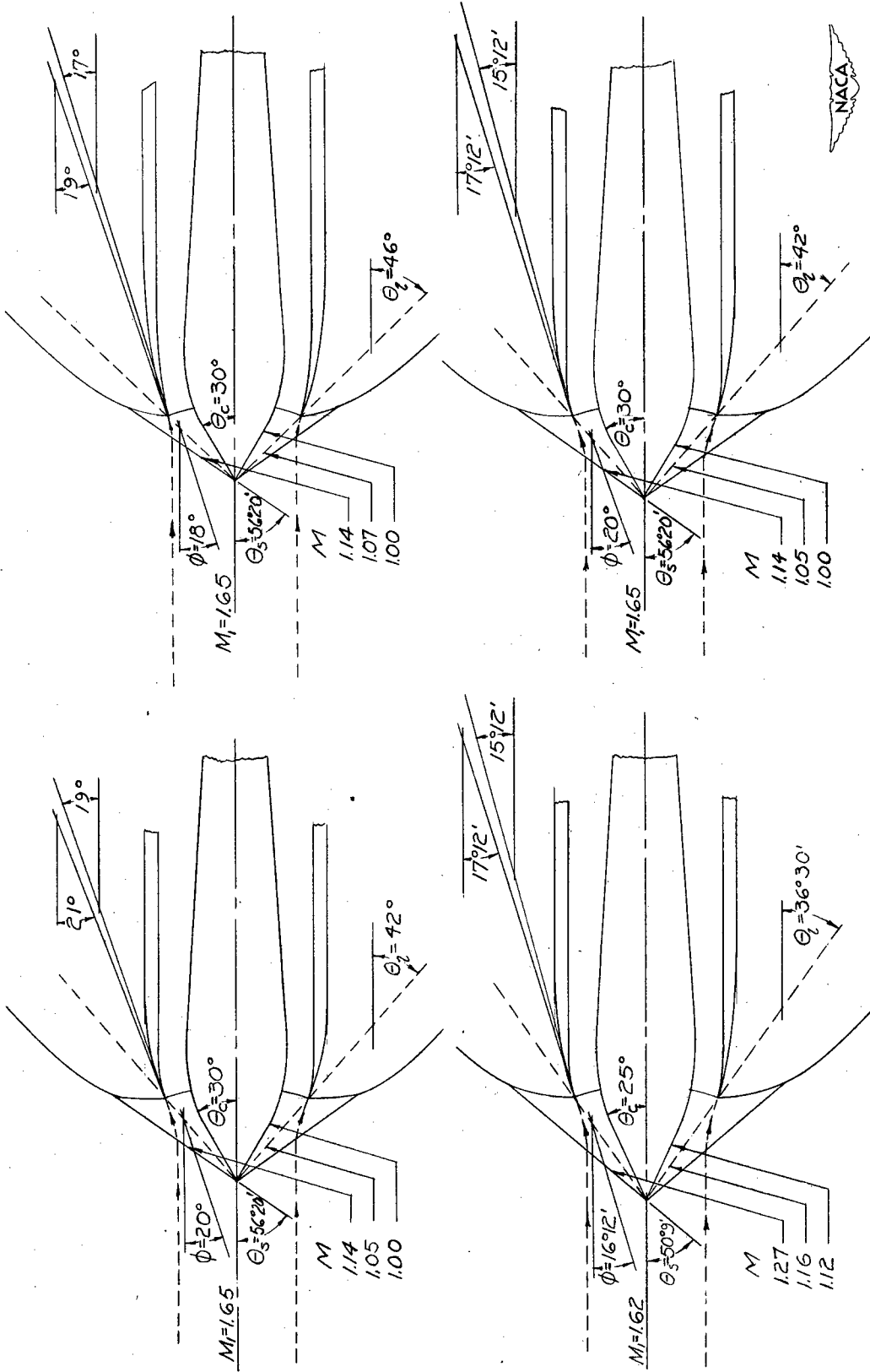
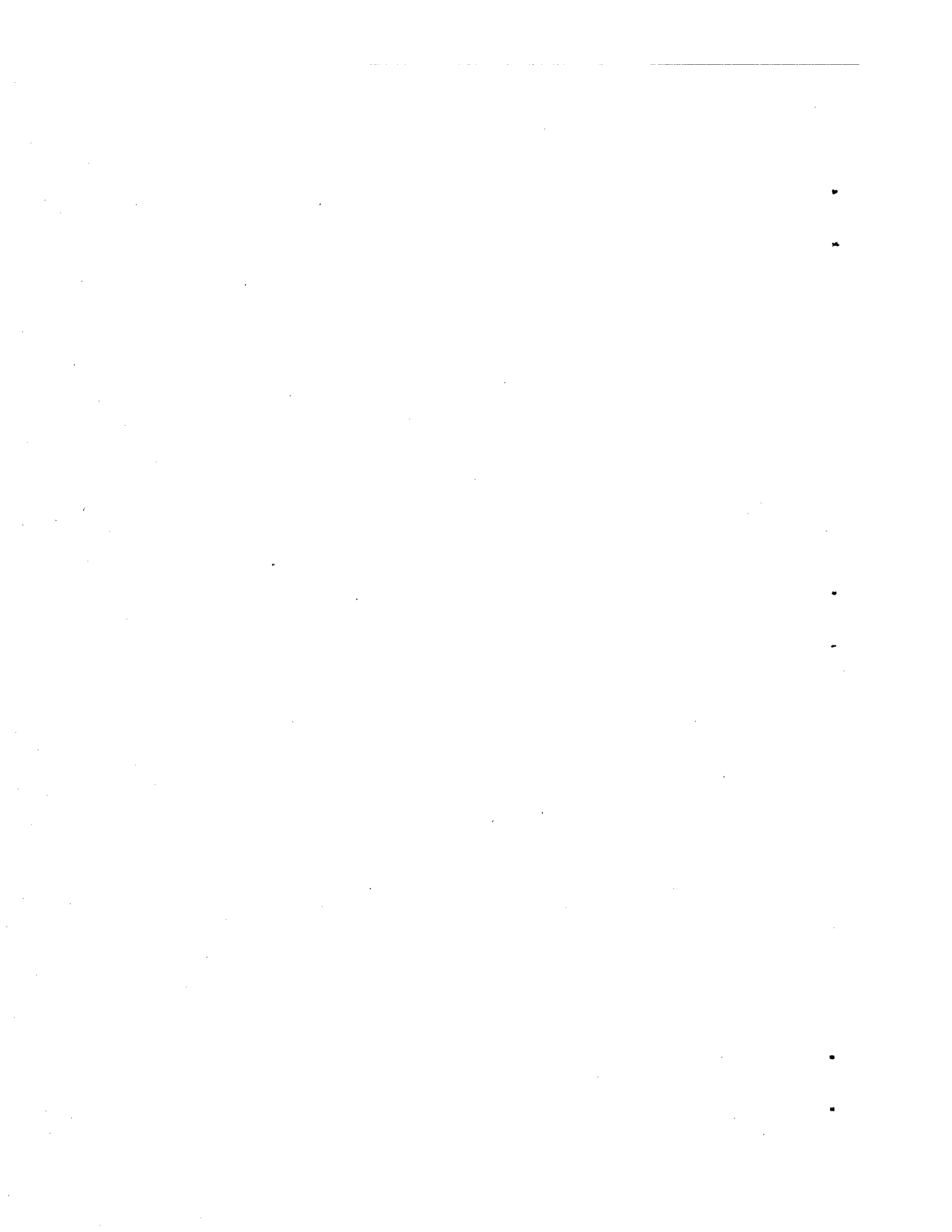

Figure 15.- Schematic diagram of the aerodynamic phenomena.





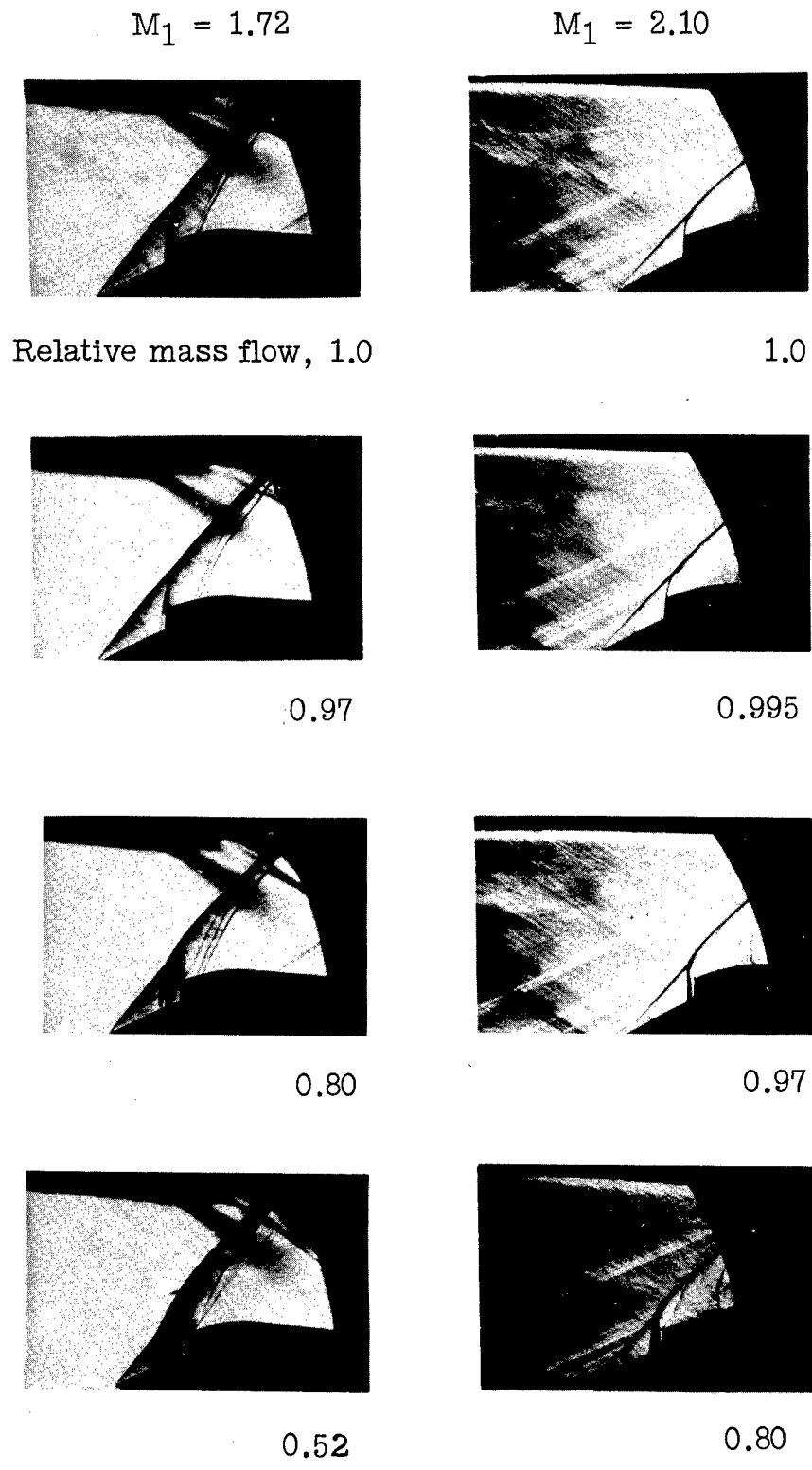

Figure 16.- Schlieren photographs for the inlet with internal compression for different values of relative mass flow.  $\theta_c = 30^\circ$ ;  $\theta_l = 42^\circ$ .

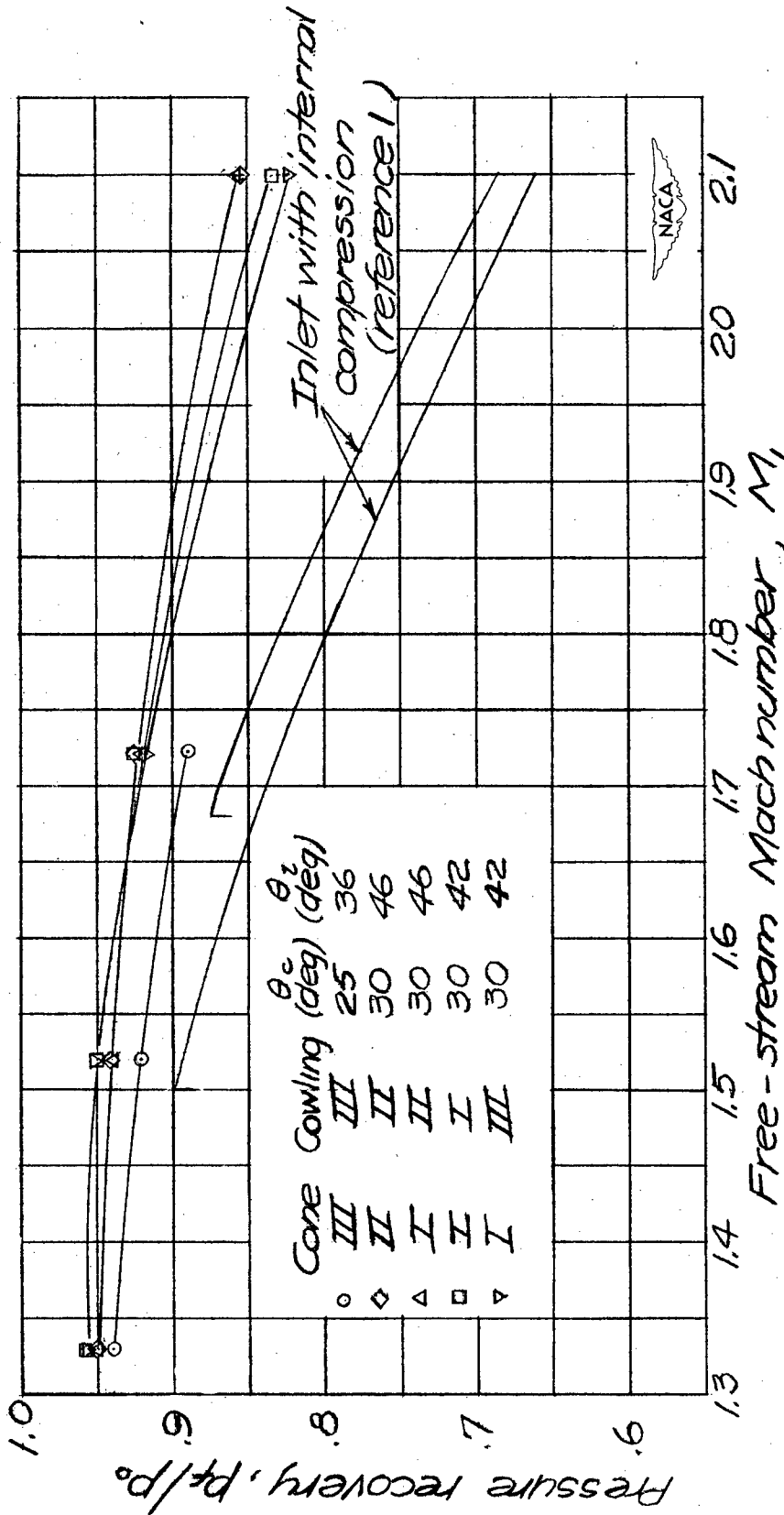

Figure 17.- Experimental values of pressure recovery for the optimum conditions as a function of free-stream Mach number for fixed-geometry inlet.

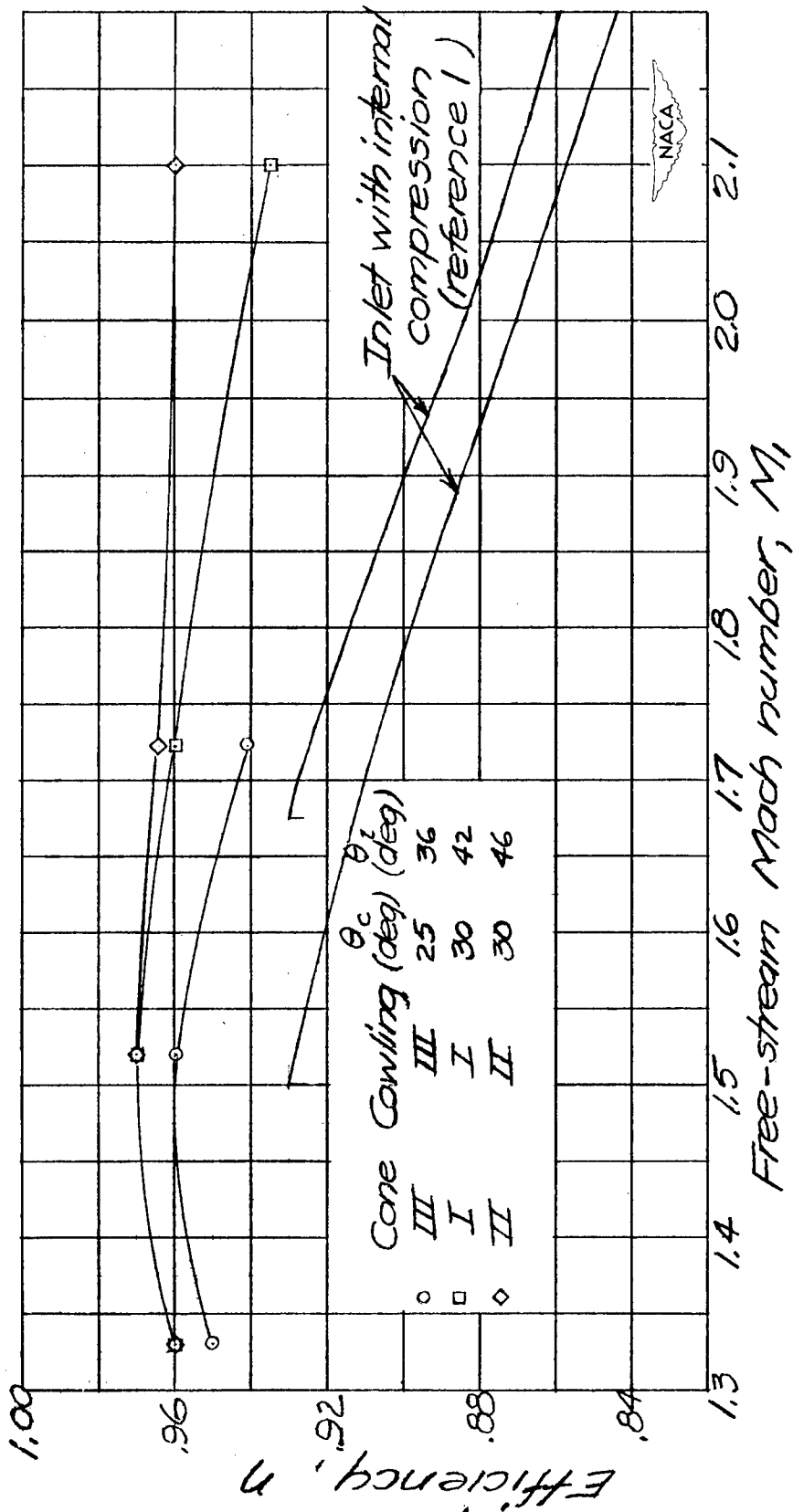

Figure 18.- Experimental values of efficiency for the optimum conditions as a function of free-stream Mach number for fixed-geometry inlet.

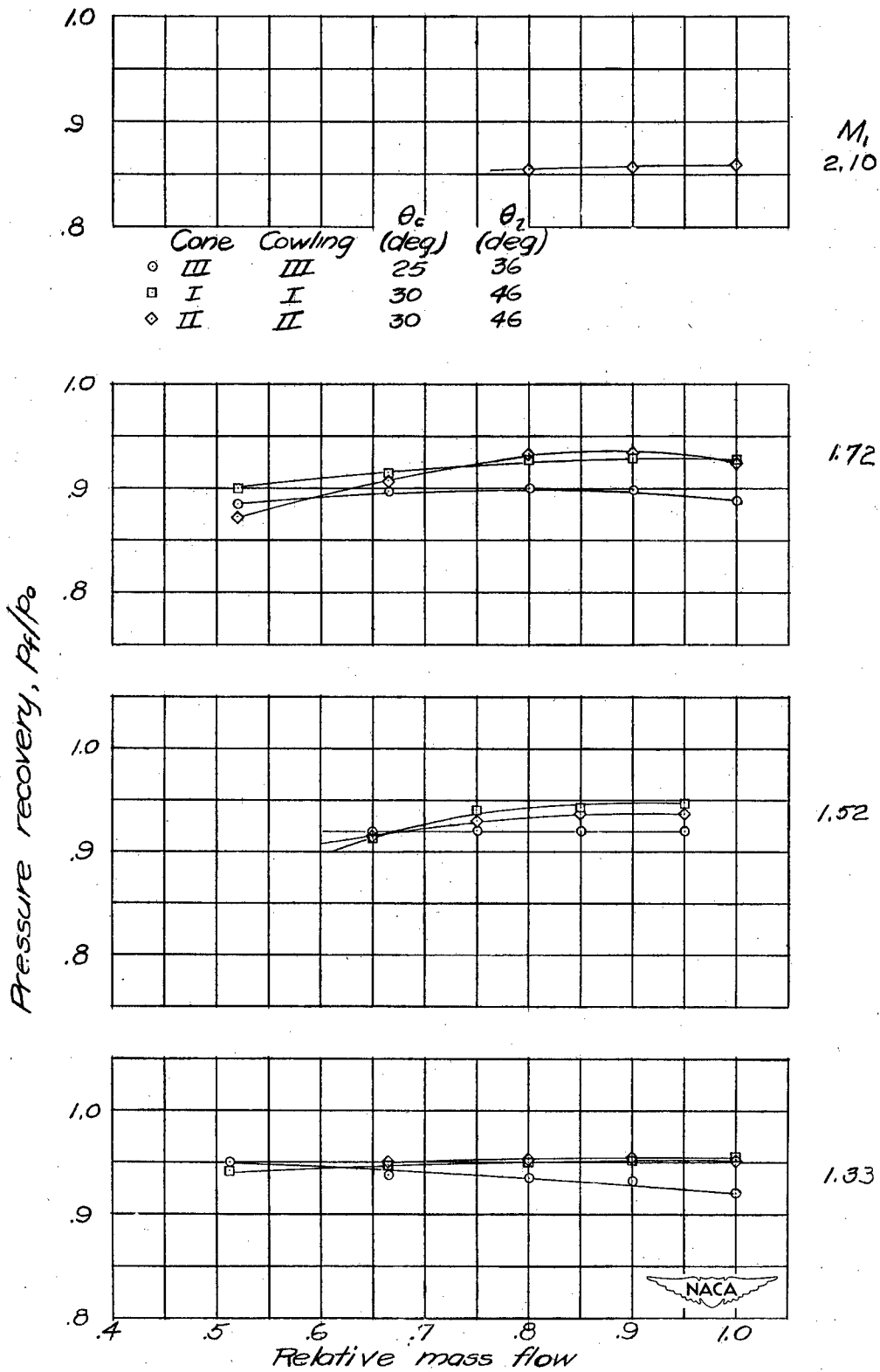

Figure 19.- Variation of pressure recovery with the relative mass flow.

1.4.1.1.3  
S

Air Inlets - Central,  
Supersonic



Preliminary Investigation of a New Type of  
Supersonic Inlet.

By Antonio Ferri and Louis M. Nucci  
NACA TN 2286  
April 1951

(Abstract on Reverse Side)

1.4.2.1.1  
S

Diffusers, Supersonic



Preliminary Investigation of a New Type of  
Supersonic Inlet.

By Antonio Ferri and Louis M. Nucci  
NACA TN 2286  
April 1951

(Abstract on Reverse Side)

1.3.4.1  
S

Bodies, Ducted Nose Shape



Preliminary Investigation of a New Type of  
Supersonic Inlet.

By Antonio Ferri and Louis M. Nucci  
NACA TN 2286  
April 1951

(Abstract on Reverse Side)

Abstract

A supersonic inlet with supersonic deceleration of the flow entirely outside of the inlet is considered. A particular arrangement with fixed geometry having a central body with a circular annular intake is analyzed, and it is shown theoretically that this arrangement gives high pressure recovery for a large range of Mach number and mass flow and, therefore, is practical for use on supersonic airplanes and missiles.

Experimental results confirming the theoretical analysis give pressure recoveries which vary from 95 percent for Mach number 1.33 to 86 percent for Mach number 2.00.

These results were originally presented in a classified document of the NACA in 1946.

Abstract

A supersonic inlet with supersonic deceleration of the flow entirely outside of the inlet is considered. A particular arrangement with fixed geometry having a central body with a circular annular intake is analyzed, and it is shown theoretically that this arrangement gives high pressure recovery for a large range of Mach number and mass flow and, therefore, is practical for use on supersonic airplanes and missiles.

Experimental results confirming the theoretical analysis give pressure recoveries which vary from 95 percent for Mach number 1.33 to 86 percent for Mach number 2.00.

These results were originally presented in a classified document of the NACA in 1946.

Abstract

A supersonic inlet with supersonic deceleration of the flow entirely outside of the inlet is considered. A particular arrangement with fixed geometry having a central body with a circular annular intake is analyzed, and it is shown theoretically that this arrangement gives high pressure recovery for a large range of Mach number and mass flow and, therefore, is practical for use on supersonic airplanes and missiles.

Experimental results confirming the theoretical analysis give pressure recoveries which vary from 95 percent for Mach number 1.33 to 86 percent for Mach number 2.00.

These results were originally presented in a classified document of the NACA in 1946.