

Effects of Damage on Interfacial Crack Tip Fields

T. C. Miller

Air Force Research Laboratory
Edwards Air Force Base, California 93524

Summary

Critical cracks can form along or near the interface between two rubbery particulate composite materials. Damage near these cracks can affect the shape and size of the crack tip fields in the two materials. In this study, finite elements are used to simulate damage near an interfacial crack tip to discover how this damage affects the crack tip fields. The effects of damage zones of different sizes on the magnitude and phase angle of the complex stress intensity factor are studied.

Modeling Aspects

Finite elements are used to study damage effects near an interfacial crack tip. The description of interfacial fracture involves complex variables and inherent mode mixity. Conventional finite element packages seldom solve for the individual components of the complex stress intensity factor, and the use of interaction integrals or a modified virtual crack extension method is often needed to fully characterize K . However, for this work, a method often referred to as the *semi-energetic method* is used because it is easy to understand and implement [1]. However, to use this method, a fine mesh is required near the crack tip. Because of this, the finite element models used in this study have a fine spider web mesh near the crack tip. The innermost element ring has quadrilateral elements that are degenerated into triangular elements with side nodes at the quarter point position. The coincident nodes at the crack tip have all been equivalenced. The element rings are radially biased so that the element lengths are all related to the innermost ring by $L_i = (i + 2)L_0$. The use of a graded mesh such as this avoids use of an excessive number of elements but still gives reasonable refinement near the crack tip.

The remainder of the mesh is relatively coarse; the specimen has large dimensions to prevent boundaries from interacting with either the damaged regions or the crack tip. The different loadings were applied using traction boundary conditions on the top surface and fixed displacement conditions on the bottom surface. Figure 1 shows a typical finite element model and the related boundary conditions (the damaged regions are shown in Figure 2).

Analysis of data

The analysis uses the semi-energetic method to determine the stress intensity phase angles and the domain integral method to determine the magnitude. A brief explanation of interfacial fracture mechanics is necessary. A paper by Williams in 1959 discussed stress fields near an interfacial crack tip and paralleled a previous analysis for a crack in a single material [2]. The problem is posed as a boundary value problem with traction free crack faces and continuity of tractions and displacements across the bonded part of the interface. This results in an eigenvalue problem with eight unknowns, the solution of which is described by its characteristic polynomial. The analysis becomes unusual at this point, because the roots of this characteristic polynomial are complex. The imaginary part of the roots of the characteristic polynomial is referred to as λ_j by Williams and is later called the *bimaterial parameter* ε by other authors. The value depends on the elastic constants of the two materials and the stress state.

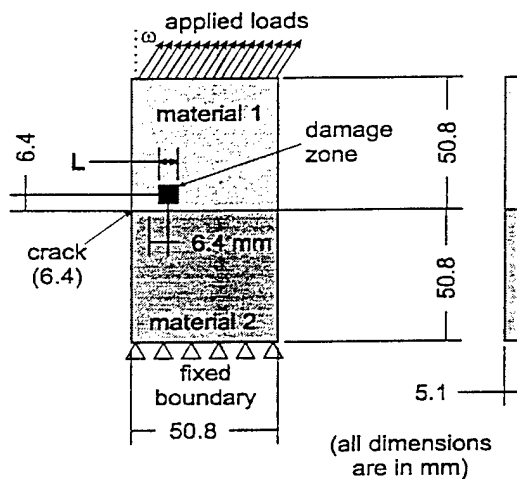

Material	Young's modulus [kPa]	Poisson's ratio
Material 1	2784	0.5
Material 2	5568	0.5
Damaged	696	0.5

Figure 1 — Specimen geometry and material properties

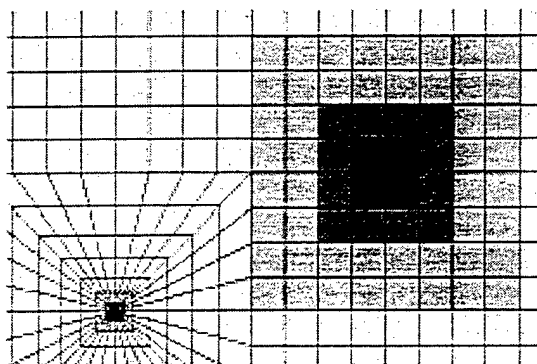

Figure 2 — Location and size of damage zones with respect to crack tip. Damage zones shown are in material 1, and have edge lengths of 3.175, 6.35, and 12.7 mm

The roots of the characteristic equation $(\lambda_r + i\lambda_i)$ form an infinite series, so the Airy stress equation is an infinite series, with each series term containing a complex coefficient. Very near the crack tip, the first term, being proportional to $r^{-1/2}$, eclipses all of the higher order terms. Therefore, the displacements, strains, and stresses near the crack tip can be described adequately by this single term, and these field expressions are referred to as *asymptotic* or *near-tip field expressions*. The coefficient of the first term is equal to K' , the stress intensity factor for an interfacial crack (within a multiplicative constant), and relates to the stresses along the interface ahead of the crack tip through:

$$(\sigma_{yy} + i\sigma_{xy})_{\theta=0} = \frac{K' \left(\frac{r}{h}\right)^{is}}{\sqrt{2\pi r}} \quad (1)$$

Here K' is the complex stress intensity factor, r is the radial distance from the crack tip, ε is the bimaterial parameter, and σ_{yy} and σ_{xy} are normal and shear stress components. The stress intensity factor here is the normalized one proposed by Rice and has dimensions of (stress $\sqrt{\text{length}}$); the length scale used for normalization is the arbitrary dimension h (in this work, h was taken as the crack size, 6.35 mm) [3]. The displacements near the crack tip are also asymptotic field expressions; in the unloaded body points on the top and bottom crack surfaces will be adjacent, but move apart on loading. The *relative crack flank displacement vector* defined as:

$$\delta = \delta_y + i\delta_x = (u_y + iu_x)_{\theta=\pi} - (u_y + iu_x)_{\theta=-\pi} \quad (2)$$

Here the relative crack flank displacement vector δ has normal and shear components d_y and d_x and the terms in parentheses describe the top and bottom surfaces of the crack, respectively. The complex vector δ is related to K' and r and this relationship is used in the semi-energetic method by expressing it in terms of magnitudes and phase angles. The magnitudes of K' and δ are related by [1]:

$$|K'| = \frac{\sqrt{2\pi(1+4\varepsilon^2)} |\delta| E^* \cosh(\pi\varepsilon)}{8\sqrt{h}\sqrt{r/h}} \quad (3)$$

Here E^* is given by $1/E^* = (1/E_1 + 1/E_2)/(2 \cosh(\pi\varepsilon))$; E_1 and E_2 are Young's moduli for the two materials under plane stress conditions and $E_1/(1-\nu_1^2)$ and $E_2/(1-\nu_2^2)$ for plane strain conditions (ν is Poisson's ratio). Also, if we denote the phase angles of K' , δ , and $1+2i\varepsilon$ by ψ' , φ , and β , respectively, then [1]:

$$\psi' = \varphi - \varepsilon \ln\left(\frac{r}{h}\right) + \beta \quad (4)$$

Finally, there exists a relationship between the J integral and the magnitude of K' [1]:

$$|K'| = \sqrt{J E^*} \quad (5)$$

The above equations show that there are two alternative methods to determine $|K'|$. Equation (5) is easy to use because finite element programs frequently give values for the J integral. This is because the methods used to calculate J are surface integrals (in two dimensions) or volume integrals (in three dimensions), and so are easy to implement in finite element calculations using Gaussian integration point approximations. This also makes the calculations robust with respect to mesh structure — J is insensitive to the mesh design or its level of refinement. So, for the results given in the next section, equation (5) was used to determine $|K'|$ (the specific method used was the *domain integral method*).

Having determined a value for the magnitude of K' , the phase angle must next be determined. However, equations (3) and (4), which are based on crack flank displacements, are only approximations since they are somewhat mesh sensitive and vary with the choice of r . The central premise of the semi-energetic method is that

the appropriate choice for r is that which results in the closest agreement for $|K'|$ when calculated using equations (3) and (5) with J already determined in an independent matter (such as the domain integral method) [1].

In practice, the J integral is first calculated using equation (5). Next, the value of $|K'|$ is found for each pair of (originally coincident) crack face nodes. The radial distance for the nodal pair where the two $|K'|$ values are closest becomes the value for r used in equation (4) to calculate the phase angle ψ' . This is illustrated in Figure 3.

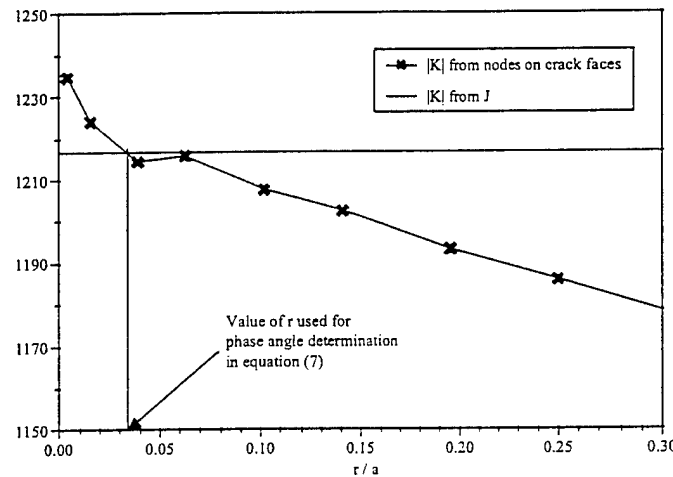

Figure 3 — Determining suitable radius value for phase angle calculations

Results

Figure 2 shows the location of the damage zones. In all cases the damage zones were located 6.4 mm in front of the crack tip and 6.4 mm from the interface, although the size, L , of the damage zones were varied. Damage zones in both material 1 and material 2 were considered and were modeled by assigning a reduced value for Young's modulus to the damaged area (1/4 of the value of material 1; the material properties are given in Figure 1). Additionally, the loading direction, ω , was varied, so that 32 separate conditions were analyzed. Table 1 summarizes the variations in the parameters.

Table 1 — Variables considered in the analysis

Damage zone sizes considered [mm]	0.000 (undamaged), 3.175, 6.350, 12.700
Location of damage zone	Damage in both materials 1 and 2 considered
Loading angle ω [degrees]	0, 30, 60, 90

The way that the damage zone size affected the magnitude of K' for the various loading angles is summarized in Table 2. The effect of the damage zone was to increase the value of $|K'|$, although the effects were small except for the largest damage zone. For the large damage zone, $|K'|$ values were elevated on the order of 20%, with similar results for damage in materials 1 and 2. In either case, the stresses are redistributed around the damage zone so that stresses are elevated on either side of it. When the damage zone size increases, this effect is intensified. Figures 4a and 4b show this phenomena for the large damage zone located in material 1;

Table 3 — Change in phase angle of stress intensity factor compared with results for undamaged specimen

Damage in material 1 (top material)					
L, size of damage zone [mm] \ Loading angle ω		0°	30°	60°	90°
		3.175	0.28	0.16	0.44
6.350	0.97	0.50	0.32	0.05	
12.700	2.15	1.59	0.19	0.26	
Damage in material 2 (bottom material)					
3.175	0.26	0.08	0.08	0.08	
6.350	0.96	0.31	0.17	0.24	
12.700	2.43	0.63	0.08	0.76	

Conclusions

The effect of damage near interfacial crack tips has been analyzed using finite element methods and accompanying calculations using the semi-energetic method. The presence of damage near the tip of an interfacial crack redistributes the stresses so that the stresses are raised near the crack tip, resulting in a higher value for the magnitude of the complex stress intensity factor. The damage zones have less effect on the phase angle of the stress intensity factor, however, because the normal and shear components are similarly affected. The size of the damage zone is a critical factor; small damage near the crack tip has a negligible effect but larger damage zone sizes can significantly elevate the stress intensity factor magnitude. The use of finite elements to study these effects in a simple manner has hopefully helped to explain this influence. However, the complicated interaction between damage and interfacial crack tips requires further study using both modeling and experimental methods.

References

1. Matos, P. P. L., McMeeking, R. M., Charalambides, P. G., and Drory, M. D. (1989): "A Method for Calculating Stress Intensities in Bimaterial Fracture", *International Journal of Fracture*, Vol. 40, pp. 235-254.
2. Williams, M. L. (1959): "The Stresses around a Fault or Crack in Dissimilar Media", *Bulletin of the Seismological Society of America*, Vol. 49, pp. 199-204.
3. Rice, J. R. (1988): "Elastic Fracture Mechanics Concepts for Interfacial Cracks", *Journal of Applied Mechanics*, Vol. 55, pp. 98-103.