

*Army Research Laboratory*



**A Revised Design for the MMS-P:  
The MMS-P January 1998 Demo Design and  
Proposed Changes**

By  
Edward Vidal Jr.  
Edward M. Measure  
Miguel A. Suriano

**Computational and Informational Sciences Directorate  
Battlefield Environment Division**

**ARL-TR-1042**

**September 2000**

*Approved for public release; distribution unlimited*

**DTIC QUALITY INSPECTED 4**

**20000927 005**

## NOTICES

### Disclaimers

The findings in this report are not to be construed as an official Department of the Army position, unless so designated by other authorized documents.

Citation of manufacturers' or trade names does not constitute an official endorsement or approval of the use thereof.

# REPORT DOCUMENTATION PAGE

Form Approved  
OMB No. 0704-0188

Public reporting burden for this collection of information is estimated to average 1 hour per response, including the time for reviewing instructions, searching existing data sources, gathering and maintaining the data needed, and completing and reviewing the collection of information. Send comments regarding this burden estimate or any other aspect of this collection of information, including suggestions for reducing the burden to Washington Headquarters Services, Directorate for information Operations and reports, 1215 Jefferson Davis Highway, Suite 1204, Arlington, VA 22202-4302 and to the Office of Management and Budget, Paperwork Reduction Project (0704-0188), Washington, DC 20503.

1. AGENCY USE ONLY (Leave Blank)		2. REPORT DATE September 2000	3. REPORT TYPE AND DATES COVERED	
4. TITLE AND SUBTITLE A Revised Design for the MMS-P: The MMS-P January 1998 Demo Design and Proposed Changes			5. FUNDING NUMBERS	
6. AUTHOR(S) Edward Vidal Jr., Edward M. Measure, Miguel A. Suriano				
7. PERFORMING ORGANIZATION NAME(S) AND ADDRESS(ES) U.S. Army Research Laboratory Computational and Information Sciences Directorate ATTN: AMSRL-CI-EA White Sands Missile Range, NM 88002-5501			8. PERFORMING ORGANIZATION REPORT NUMBER ARL-TR-1042	
9. SPONSORING/MONITORING AGENCY NAME(S) AND ADDRESS(ES) U.S. Army Research Laboratory 2800 Powder Mill Road Adelphi, MD 20783-1145			10. SPONSORING/MONITORING AGENCY REPORT NUMBER ARL-TR-1042	
11. SUPPLEMENTARY NOTES				
12a. DISTRIBUTION/AVAILABILITY STATEMENT Approved for public release distribution unlimited.			12b. DISTRIBUTION CODE A	
13. ABSTRACT (Maximum 200 words)  Accurate artillery first round fire-for-effect requires correction for the effects of the atmosphere on the trajectory. Wind, density, and speed of sound effects, if not properly compensated, produce very large errors. The traditional method for computing the corrections is based on measurement of the atmosphere using a balloon-borne radiosonde.  The Meteorological Measuring Set Profiler will supplement or replace the balloon-borne radiosonde with remote sensing techniques, and the single radiosonde profile through the atmosphere will be replaced by a meteorological model which provides a 4-dimensional (3 dimensions of space plus time) representation of the atmospheric state in the battle zone. These changes not only provide more timely meteorology, but also provide meteorology in the launch area, at apogee, and in the target area. The system design described here links major components by Ethernet and uses Java to interface with individual components and manage overall system functions.  The Java-based system integration scheme proved its ability to integrate a diverse group of sensors operated by computers using several different operating systems.				
14. SUBJECT TERMS artillery meteorology, profiler, system design			15. NUMBER OF PAGES 57	
			16. PRICE CODE	
17. SECURITY CLASSIFICATION OF THIS REPORT UNCLASSIFIED	18. SECURITY CLASSIFICATION OF THIS PAGE UNCLASSIFIED	19. SECURITY CLASSIFICATION OF ABSTRACT UNCLASSIFIED	20. LIMITATION OF ABSTRACT SAR	

# Preface

This report describes the design of a proof-of-concept profiler systems for measuring meteorological corrections for Army artillery.

## Contents

Preface.....	1
Executive Summary .....	5
1.0 Introduction .....	7
1.1 Background.....	7
1.2 The MMS-Profiler Proof-of-Concept System.....	7
1.3 Purpose/Objective.....	8
2.0 Three Versions of the MMS.....	9
2.1 The Fielded MMS.....	9
2.2 The MMS-P as of January 1998.....	9
2.3 The MMS-P (Revised Version).....	9
3.0 MMS-P Sensors and Systems .....	11
3.1 Design Concepts .....	11
3.2 Sensors and Subsystems .....	12
3.3 Hardware Interconnection Design.....	13
4.0 Data Flow in the MMS.....	15
5.0 Data Flow in MMS-P98.....	17
5.1 Surface Sensor .....	18
5.2 MARWIN Data Flow.....	20
5.3 Radiometer Data Flow in the MMS-98 .....	21
6.0 Connections and Data Flow in the MMS-P (RV).....	23
6.1 SMS and MARWIN Data Flow in the MMS-P (RV).....	24
6.2 Radiometer Data Flow in the MMS-P (RV).....	26
7.0 Combined LCU and CAAM/BFM Functions.....	27
8.0 Remaining Issues .....	29
8.1 Connections and Interfaces.....	29
8.2 Data Transfer from SEASPACE Satellite System.....	30
9.0 Conclusions .....	31
References .....	33
Acronyms .....	35
Appendices	
Appendix A. Clientun.c.....	37
Appendix B. ServerList.java .....	43
Distribution.....	47

## Figures

1. MMS-P hardware interconnection, January 1998 demonstration.....	14
2. MMS hardware connection diagram .....	15
3. Connections of the eight-port boards in the MMS-P98 .....	17
4. SMS data flow in MMS-P98.....	19
5. MARWIN data flow in MMS-P98.....	20
6. Radiometer data flow in the MMS-98 .....	21
7. MMS-P (RV) system connectivity.....	23
8. SMS and MARWIN data flow into SCO Unix computer.....	24
9. Data Flow from Marwin to SCO Unix computer.....	25
10. Radiometer data flow, proposed changes.....	26
11. System connectivity, unresolved issues.....	29

# Executive Summary

## General

Accurate artillery first round fire-for-effect requires correction for the effects of the atmosphere on the trajectory. Wind, density, and speed-of-sound effects (mediated by virtual temperature effects), if not properly compensated, produce very large errors. The traditional method for computing the corrections is based on measurement of the atmosphere using a balloon-borne rawinsonde. Unfortunately, rawinsonde launches are expensive and time consuming. Current systems can only track one balloon at a time; therefore, by necessity, balloon launches are widely spaced in time. The necessity of a hydrogen generator or a supply of helium adds logistical complexity. Finally, the rawinsonde can only make measurements along the trajectory of the balloon, which goes where the wind blows it.

The Met Measuring Set Profiler (MMS-P) is intended to supplement the balloon-borne rawinsonde with remote sensing techniques. The single rawinsonde profile through the atmosphere will be replaced by a meteorological model product which provides a 4-dimensional (3 dimensions of space plus time) representation of the atmospheric state in the battle zone. These changes not only provide more timely meteorology but also provide meteorology in the launch area, at apogee, and in the target area.

Development of a proof-of-concept system embodying extensive previous research was begun in FY 1997. Because the system was based on integrating several existing sensor systems with the current Met Measuring Set (MMS), and each component used a different operating system and proprietary software, the resulting system integration task presented many challenges. The adopted system concept linked major components by Ethernet and used JAVA to interface with individual components and manage overall system functions.

In January of 1998, a full-scale demonstration of system and sensor connectivity and communication was conducted. The present report describes the system configuration at the time of the demonstration and discusses the lessons learned from that demonstration. A principal result of the demonstration was to prove the feasibility of integrating the hardware using the JAVA-based system concept and

system integration software. It revealed, however, several opportunities for simplifying, streamlining, and otherwise improving the efficiency and increasing the capability of the system.

## **Conclusions**

The JAVA-based system integration scheme proved its ability to integrate a diverse group of sensors operated by computers using several different operating systems. Opportunities for optimization remain.

## **Recommendations**

With the basic soundness of the system demonstrated, future efforts should concentrate on improving the system speed, simplicity, and efficiency within the overall conceptual scheme. Decreasing the physical volume of the processing hardware should remain a priority.

# 1.0 Introduction

## 1.1 Background

Accurate artillery first round fire-for-effect requires correction for the effects of the atmosphere on the trajectory. An artillery shell is subjected to drag forces during its flight that depend on wind, density, and virtual temperature. These effects, if not properly compensated, produce very large errors. The traditional method for computing the corrections is based on measurement of the atmosphere using a balloon-borne rawinsonde. The current U.S. Army system for providing this information is the Met Measuring Set (MMS) AN/TMQ-41.

The MMS consists of a system for:

- launching and tracking balloons,
- gathering the resulting sounding data, and
- communicating it to the weapon systems.

Unfortunately, this system has several disadvantages. The consumables required by rawinsonde launches are expensive and the operation is time consuming. Current systems can only track one balloon at a time; therefore, by necessity, launches are widely spaced in time. The balloons need a supply of lighter-than-air gas for lift, which requires a hydrogen generator or a supply of pressurized helium cylinders. These constitute a hazard and add logistical complexity. Finally, the rawinsonde can only make measurements along the trajectory of the balloon, which goes where the wind blows it.

## 1.2 The MMS-Profiler Proof-of-Concept System

The U.S. Army Research Laboratory (ARL), Computational Information Sciences Directorate (CISD), Battlefield Environment Division (BED) has designed and built a proof-of-concept system replacement for the MMS, which is called the MMS-Profiler (MMS-P). While this design was conceived as a product improvement to the MMS, it incorporates far-reaching changes in design and capability. These stem from new methods for gathering, interpreting and analyzing data, especially remotely sensed data. [1,2,3]

The proof-of-concept system MMS-P has been in development for some time, starting with experiments in remote sensing technology that began in 1984 at the U.S. Army Atmospheric Sciences Laboratory (the predecessor of the current CISD, BED). The proof-of-concept evolved from isolated instruments to a fieldable collection of trailers until the technology was deemed ripe for design of an operational proof-of-concept system in early FY 1997. An initial tabletop demonstration of the integrated system was conducted in January 1998.

The MMS-P proof-of-concept system is capable of producing a vertical profile of wind speed and direction, temperature, relative humidity, and atmospheric pressure from the surface to 20 km. The system includes sensors, programs for data fusion, and a meso-scale meteorological model. The sensor suite consists of a Semi-automatic Meteorological Station (SMS), wind radar, temperature, and moisture sensing radiometric profiler, facilities for launching and tracking rawinsondes, and a satellite receiver. Several computers, interconnected by Ethernet, manage data assimilation; data fusion; and communication with the tactical network via the Single Channel Ground and Airborne Radio System (SINCGARS). Another connected computer runs a meso-scale meteorological model, the Battlescale Forecast Model (BFM). The BFM assimilates the MMS-P data, Navy Operational Global Atmospheric Prediction System (NOGAPS) model gridded data from the Air Force Weather Agency (AFWA), upper air soundings and surface data to derive and provide met messages to field artillery fire units.

### 1.3 Purpose/Objective

The purpose of the present report is to document the design of the hardware and software that handles the MMS-P data assimilation and communication. Suggestions for improving the design for faster execution are discussed. Means for reducing the number and complexity of the hardware and software interfaces are considered. The design shown represents the system as of the January 1998 demonstration.

## 2.0 Three Versions of the MMS

### 2.1 The Fielded MMS

The MMS is currently fielded as a primarily a balloon-based system. Its sensors are the SMS and the MW12 MARWIN rawinsonde system. The SMS measures surface winds, temperature, and humidity while the rawinsonde measures balloon position, temperature, pressure, and humidity aloft. The rawinsonde data is communicated by radio to the MARWIN system and then to the Lightweight Computer Unit (LCU). The SMS data goes directly to the LCU where the data is combined to produce meteorological messages that are transmitted via the SINCGARS radio system. Data flow details are shown in section 4.0 of this report.

### 2.2 The MMS-P as of January 1998

Although the MMS-P was conceived as a product improvement to the MMS, it represents a radical redesign incorporating the addition of many new sensors and greatly increased computer-processing power. The new sensors and systems of the MMS-P proof-of-concept system are discussed in detail in section 3.0 of this report. The primary purposes of the present report are to describe the basic features of the proof-of-concept system as of January 1998 (which will be referred to in this report as MMS-P98) and contrast them with some suggested design improvements.

The MMS-P of the January 1998 experiment was designed to minimize changes to the original MMS. This was motivated by two situations:

1. the need to interface with other existing systems (e.g., the SINCGARS) and
2. the idea of building the system from more or less independent modules.

### 2.3 The MMS-P (Revised Version)

The design described above minimized the changes to the LCU software but incorporated some major inefficiencies, which are described in more detail in sections 5.0 and 6.0 of this report.

These inefficiencies resulted in extra hardware and inferior system performance. Consequently, a redesign of the system was undertaken. The resulting design reduces hardware requirements and improves system performance.

## 3.0 MMS-P Sensors and Systems

This section describes the MMS-P system, with emphasis on the common features of the 1998 and revised version (RV) systems.

### 3.1 Design Concepts

Development of a proof-of-concept system embodying extensive previous research was begun in FY 1997. The concept underlying the design was the integration of a suite of sensors and information-processing technologies to replace the balloon. The principal technical barrier that was confronted was the difficulty of integrating these diverse technologies, each with its own complex hardware and software base, running on computers under four different operating systems. The expense of rewriting all the software and rebuilding all the hardware to run on a common platform would have been enormous. In addition, most of the subsystems were commercial off-the-shelf systems, much of the underlying software was proprietary. The approach adopted was a novel adaptation of state-of-the-art techniques of software reusability, networking, and the JAVA programming language. [3,4]

The MMS-P system concept links major components by Ethernet and uses JAVA to interface with individual components and manage overall system functions. The objective was the design of hardware and software that would permit data to be captured from several sensors without redesign of the individual sensor subsystems. Because networking protocols run on virtually all kinds of systems, and because of the portability and multi-threading capabilities built into JAVA, the individual sensors can operate virtually independently while the data is being gathered and stored in a database.

The top-down, object-oriented software design gives an unprecedented degree of modularity to the MMS-P's data system, because virtually any computer-controlled sensor can be plugged in as another object in the sensor class. This design represents a paradigm that can be readily adapted to a wide variety of problems where diverse sensors or other devices need to be connected and cooperating.

## 3.2 Sensors and Subsystems

The MMS-P makes use of local instruments, a local meteorological model, information communicated from remote instruments, and information from large scale models. The soundings it produces are communicated by SINCGARS radio.

The SMS, a component of the standard MMS, measures surface wind, temperature, pressure, and humidity. Its output is processed by the LCU computer and is used by the MARWIN as well as providing surface meteorology for the MMS-P.

The primary upper-air wind sensor is the 924 MHz, phased-array Doppler radar. The relative phases of the transmitting elements can be varied to transmit in each of five directions. The signal scattered from atmospheric refractive index discontinuities is Doppler shifted in proportion to the radial component of the velocity of the scattering components of the atmosphere and that Doppler shift is measured in a range-gated, heterodyne detection scheme. Vertical and horizontal winds are inferred from combinations of the radial velocities in the various directions (see, e.g., reference 3, p. 816). The range gating of the returns results in a vertical profile of the wind velocities from about 100 m above the surface to the height at which the radar runs out of signal-to-noise ratio, typically about 4 to 7 km above the surface. A dedicated radar computer processes the radar data. [3, p. 816]

The primary sensor of upper-air temperature, humidity, and liquid water is the microwave radiometer. The radiometer is a passive instrument that measures the natural microwave emissions of atmospheric oxygen, water vapor, and liquid water. Its retrievals are most accurate in the lowest 6 km of the atmosphere.

The MARWIN is the rawinsonde system used by the MMS.

The Seaspace satellite receiver system receives data for the polar orbiting meteorological satellites and can process the data to produce wind and temperature fields, as well as visual and infrared imagery.

The SINCGARS radio is the tactical communication link for the MMS and the MMS-P.

The BFM gives the MMS-P the capability to produce nowcasts and forecasts of the meteorological conditions along the trajectory, in the target areas, or anywhere else within 500-km square.

The DirecPC is a specialized satellite network system that permits global model data to be downloaded for use by the BFM. It is a receive-only system.

### 3.3 Hardware Interconnection Design

The backbone of the system is the local area network (LAN). There are five computers connected by the LAN:

- one SEASPACE Sun SPARC 20,
- three Pentium PCs, and
- one 486 PC.

A sixth computer, the Army LCU was not connected to the LAN during the January 1998 experiment. These six computers make use of four different operating systems: Solaris UNIX, Santa Cruz Operation (SCO) UNIX, Microsoft Windows NT, and Microsoft Windows 95. Listed below are these six computers, their processors, operating systems, and principal functions. The Computer Assisted Artillery Meteorology (CAAM)/BFM computer serves as a surrogate LCU, and only one of these is on the system at a time in the configurations discussed below.

Computer	Processor	Operating system	Principal functions
Sun	SPARC 20	Solaris UNIX	Satellite data receiver and processor
Radar computer	Pentium	Windows NT Workstation	Radar control and data acquisition
MPS Main	Pentium	Windows NT Server	Main, data base, serial instrument controller
CAAM/BFM	Pentium	SCO UNIX	Run BFM, create CAAM messages
DirecPC	486	Windows 95	Receive data from IMETS and NOGAPS
LCU	Pentium	SCO UNIX	Control MARWIN and SINCGARS

Note:  
MPS Mobile Profiler System

On the MPS Main (Windows NT Server) system, an eight-port module is used to ingest the data from the SMS, MARWIN, and the radiometer. Two ports are required for each sensor. On the LCU system, another eight-port module is used to ingest the data from the SMS, MARWIN, and to have access to a printer. This made for 10 serial ports between the NT and the SCO systems. This design allowed the data stream from the SMS and MARWIN to be captured in the NT system with a minimum of changes to the MMS software.

Figure 1 shows the layout of systems in the January 1998 demonstration. In the diagram, computers, instruments, and peripherals are represented by large rectangles. Lines ending in smaller, darker shaded rectangles attached to the computers represent the LAN, and lines ending in arrows represent serial connections. The zigzag lines represent radio communication via SINCGARS. The dark blue line shows data flow from the SMS to MPS Main while the green line shows it echoed to the LCU. Similarly, the sky blue line shows data flow from the MARWIN to the MPS Main and the pink line shows the MARWIN data being echoed to the LCU.

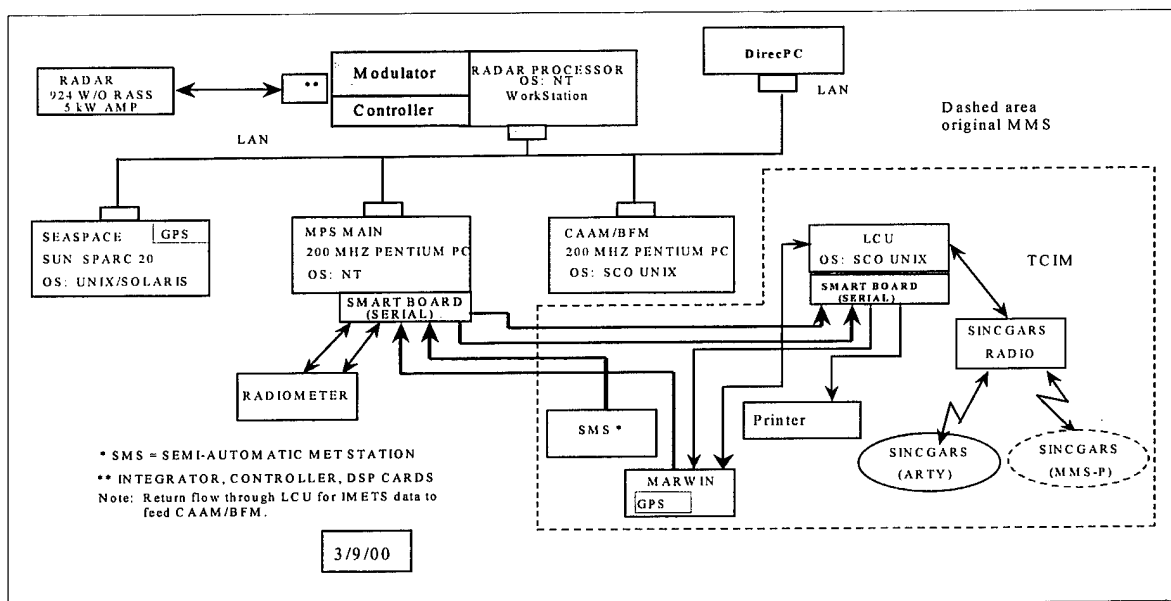

Figure 1. MMS-P hardware interconnection, January 1998 demonstration.

Note that the LCU is not connected to the LAN in the January 1998 configuration.

## 4.0 Data Flow in the MMS

Figure 2 shows the data flow in the MMS. Note that five serial connections are involved:

- one with the SMS,
- one with the printer,
- three with the MARWIN.

The connection shown from the Tactical Communications Interface Module (TCIM) to connect to the SINCGARS is a Small Computer System Interface (SCSI). One of the serial ports used is native to the LCU and the other four pass through the Digi 8, 8-serial port board. This figure will serve as a baseline for the discussion of the MMS-P98 and MMS-P (RV) below. The Digi 8 boards and the software to control them are described in an ARL report. [7]

Figure 2. MMS hardware connection diagram.

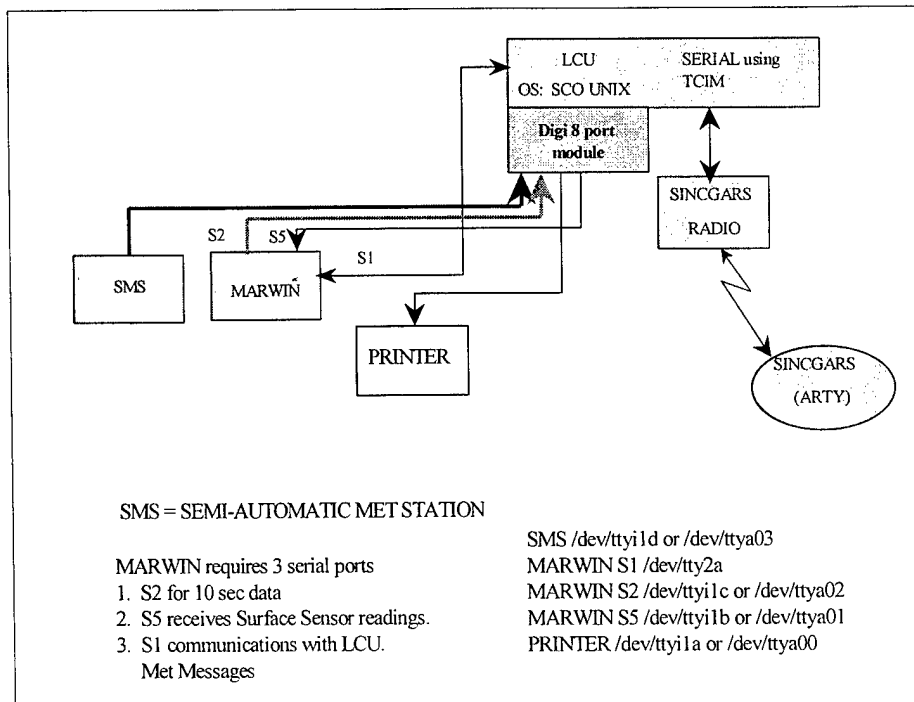

The eight-port module attached to the LCU was added to the original MMS under a Value Engineering Change Proposal (VECP) and was used for communication with the MARWIN and the LCU printer. In addition to the output communication, s2 shown in figure 2 for the MARWIN, s5 is an input to the MARWIN, and the LCU also conducts a bi-directional communication with the MARWIN through one of its native serial ports. The fourth eight-port module serial port connects the LCU to a printer.

## 5.0 Data Flow in MMS-P98

In addition to system connectivity, figure 1 (section 3.0) shows the paths of data flow in the MMS-P. The dotted line is drawn around the original MMS components. Comparison of figures 1 and 2 will show that the original MMS core looks almost unchanged. The major difference is that two data paths that go directly from instruments to the LCU in figure 2, go (figure 1) into the smart board of MPS-main computer. Two corresponding data paths also go (figure 1) from the MPS-main smartboard to the LCU smartboard.

The purpose of these changes was to make the original design of the MMS-P minimally impact the MMS software. Because the SMS and MARWIN rawinsonde observation (raob) data were needed by both the LCU and the MMS-P, a design was adopted in which the output of the SMS and MARWIN were captured by MPS Main via ports 3 and 5 of the attached eight-port module. These signals were echoed to the LCU via ports 4 and 6 of the MPS Main eight-port board and thence to the p3 and p4 ports of the smart board attached to the LCU.

Figure 3 shows the connections between the eight port boards in more detail.

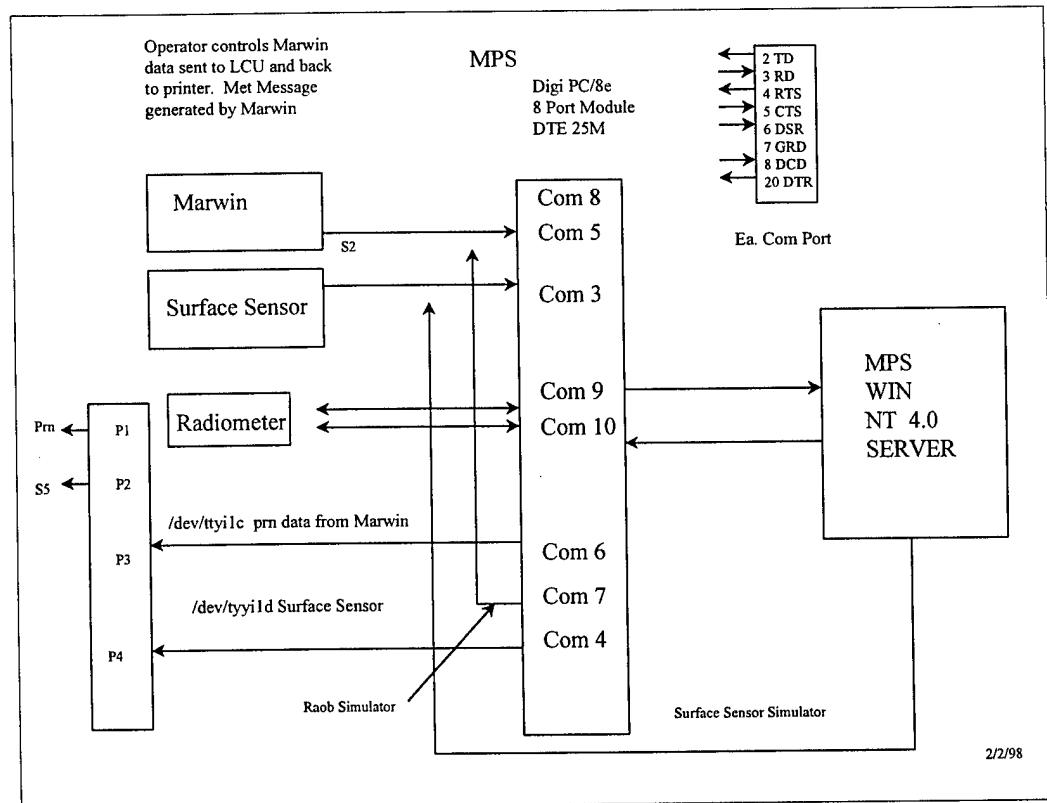

Figure 3. Connections of the eight-port boards in the MMS-P98.

This design produced minimal changes in the configuration of the original portion of the MMS but did so at a cost in efficiency. Software and system processing time were needed to process and echo the incoming signals, and delays were introduced. In addition, six ports were required to handle the signals that had formerly required only two.

The sensors and peripherals are connected to the system by serial connections to the two eight-port smart board modules. Each smart board has an onboard buffer and controls eight serial ports. A detailed interconnection for the two eight-port modules is shown in figure 3. In the figure, the large rectangle in the center represents the eight-port module attached to the MPS main computer; the smaller rectangle at the lower left represents the same on the LCU (only four of the eight ports are shown).

The MPS main computer can run simulators for the SMS surface sensor and the MARWIN balloon system. When the system is run in that mode, the simulated MARWIN output is sent from COM 7 to COM 5 in place of the actual MARWIN s2 output. Similarly, simulated SMS output is sent from an MPS native serial port to COM 3. The real or simulated MARWIN data coming in on COM 5 is sent out to the LCU via COM 6 (of the MPS smart board) and p3 (of the corresponding LCU module). Similarly, SMS data gets to the LCU via COM 4 and p4.

## 5.1 Surface Sensor

Data flow from the SMS AN/TMQ-50 (surface sensor) and supporting software is diagrammed in figure 4.

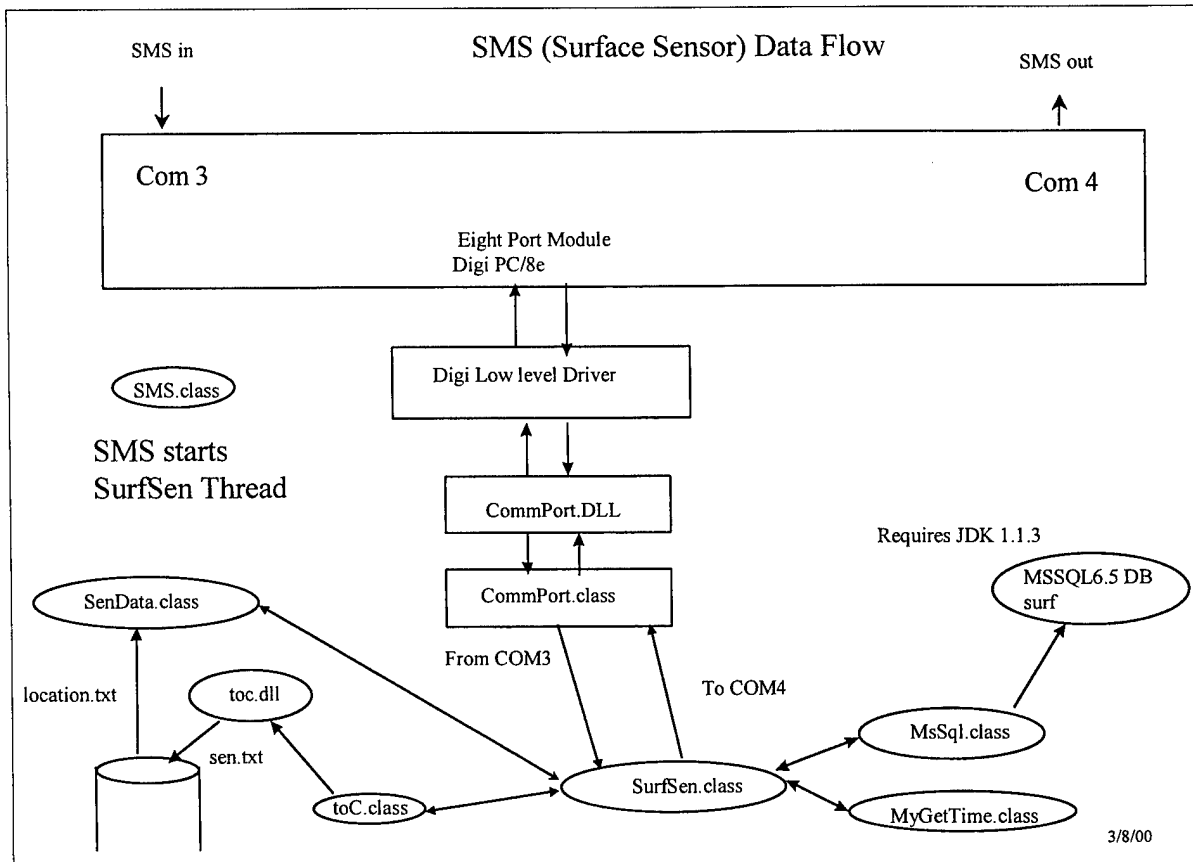

Figure 4. SMS data flow in MMS-P98.

In a conventional MMS, SMS data would flow directly from the sensor to p4 of the LCU, but in the MMS-P98, the SMS data is first intercepted and stored in two forms on the MPS computer. In the figure, the three rectangular boxes below the eight-port module rectangle represent the software interface with the MPS main computer. From top to bottom, they are respectively, the Digi eight-port board, low-level interface; the Windows NT (*CommPort.dll*) interface; and the JAVA (*CommPort.class*) interface. The ovals below represent JAVA objects.

The *SMS.class* program instantiates the *SurfSen.class* program, which is the central communication node for the SMS sensor, receiving data from and sending data to the eight-port module, sending data via the *toC.class* to a C program that stores data to the *sen.txt* file. It also receives location data, derived ultimately from the Global Positioning System (GPS).

The combined data is time stamped and sent to be stored in the Microsoft Standard Query Language (MSSQL) database. The data sent back to the eight-port module goes to the LCU, and then to the MMS SCO Unix system, where it is processed (wind direction converted from mills to degrees and wind speed converted to meters per second) and output on `/dev/tty1b` for input to the MARWIN. The LCU supplies data to the MARWIN processor and uses the data in an extrapolation model that in turn produces a nine line met message from surface observations. A UNIX pipe of the surface data is located in `/usr/RUN/surfsin`.

## 5.2 MARWIN Data Flow

An analogous data flow diagram for the MARWIN data flow is given below in figure 5. Note the strong structural similarities in the software design, a feature of the object oriented modular design.

The design (January 1998) calls for five serial ports on the LCU—the SMS and MARWIN data from MPS Main, the two-way channel S1 to

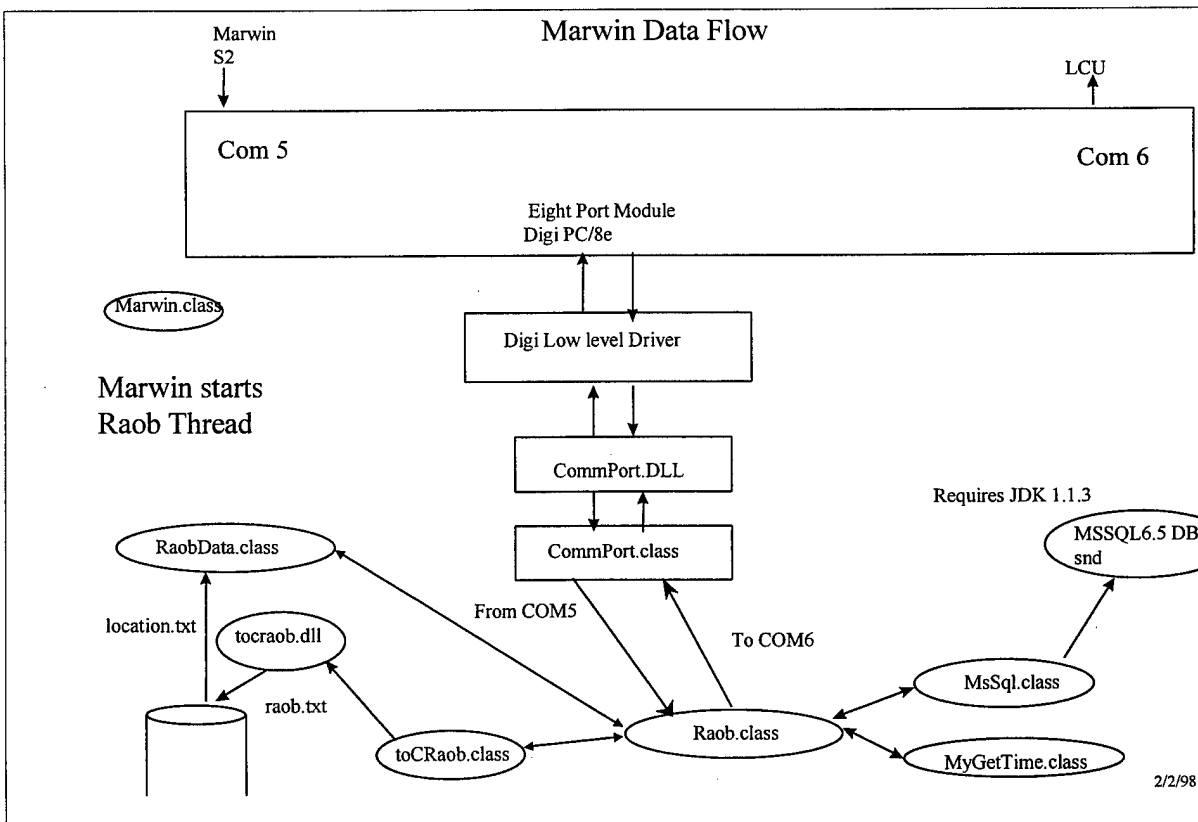

the MARWIN, S5 to the MARWIN, and output to a serial printer.

Figure 5. MARWIN data flow in MMS-P98.

### 5.3 Radiometer Data Flow in the MMS-98

The final system directly affected by the proposed revisions is the radiometer. Figure 6 below shows the software outline for the radiometer in the 1998 configuration. The drastically different structure compared with figures 4 and 5 reflects the difficulties inherent in incorporating its software, which was written as a stand-alone disk operating system (DOS) program, into the modular architecture.

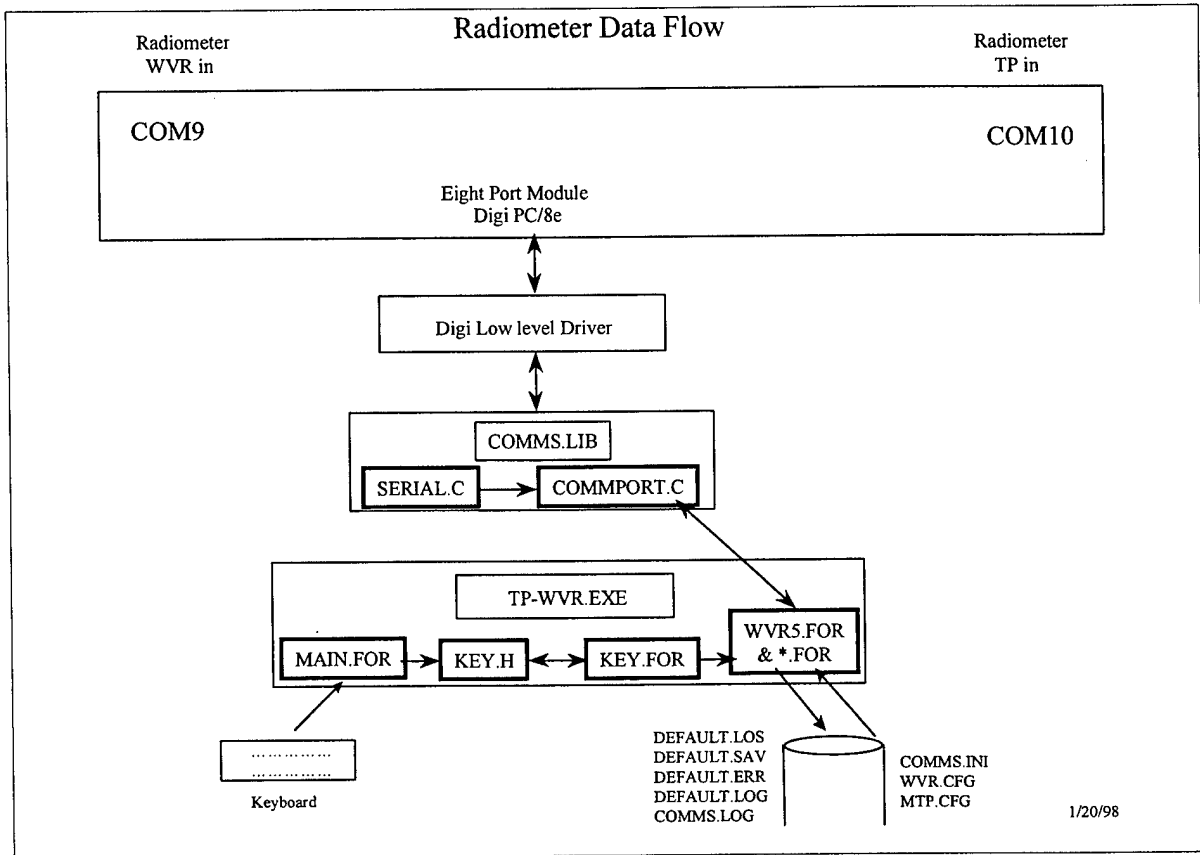

Figure 6. Radiometer data flow in the MMS-98.

## 6.0 Connections and Data Flow in the MMS-P (RV)

The design shown in figure 1 minimized the changes to the LCU software but incorporated two major inefficiencies—the delay and additional ports entailed by the shuffling of the data first into MPS Main and then to the LCU. An even more important problem is connectivity with the LCU, which lacks the capability to connect to the LAN.

The rationale for this design was that the MMS-P required the data provided by the SMS and this design minimized the changes to be made since the MMS-P was simply placed in the data flow of the SMS to the MMS. It was already planned that the LCU software would be transported to another SCO UNIX computer with room for a LAN card. This was not implemented in the January 1998 configuration though, because we had not yet been able to solve the problem of integrating the TCIM (connecting the computer to the SINCGARS) on the computer.

Since then, a more detailed understanding of the LCU code has revealed important potential improvements. The TCIM problem was solved, and the LCU code was transported to a more flexible computer. In addition, it was learned that the MARWIN and SMS data go to UNIX data pipes. Consequently, it is simple to put UNIX Tees in the pipes to send the data to one or more other locations.

These facts make possible the following revised design, shown in figure 7 below.

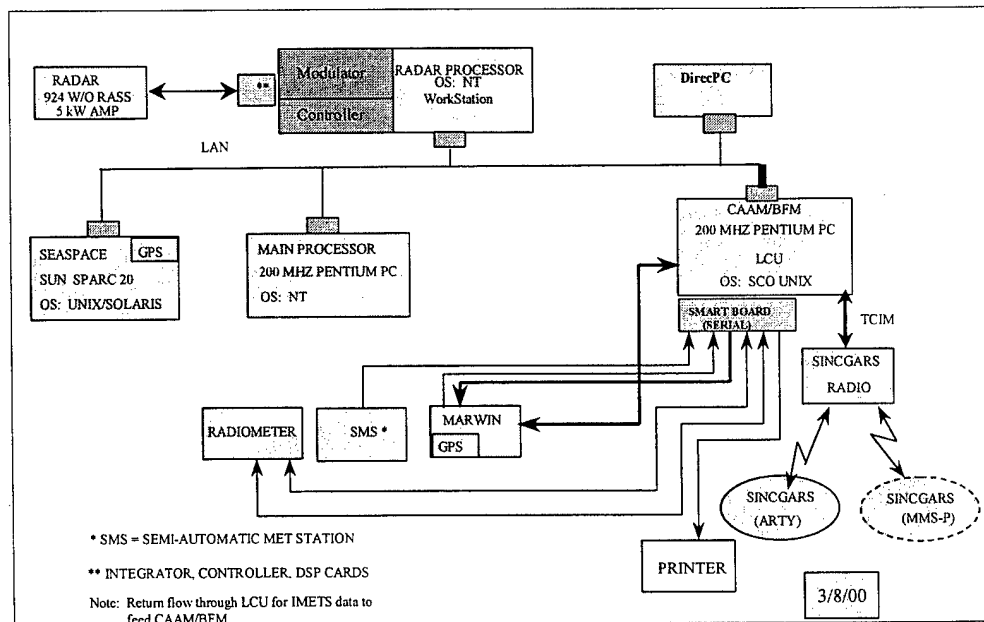

Figure 7. MMS-P (RV) system connectivity.

The design includes a LAN connection to the LCU replacement (shown as the heavy black line) and now provides full connectivity of all MMS-P systems, which is essential for an automated system. The design in figure 7 also simplifies and speeds up the data transfer from the SMS and MARWIN. Four serial ports are eliminated, see specific sections devoted to the MARWIN and SMS below.

The remaining design issue concerns how the data should be shared among the computers. Options considered included sockets, hypertext transfer protocol (HTTP), and the SAMBA file system. The SAMBA file system permits a UNIX system to share a disk drive with Windows systems. The SAMBA system, running on the LCU, was adopted because it provided a good mix of simplicity and flexibility.

### 6.1 SMS and MARWIN Data Flow in the MMS-P (RV)

The new system design used with SAMBA frees COM3 and COM4 on the MMS-P system. Figure 8 shows the data flow of the SMS and MARWIN data into the SCO system where the processing takes place and the data is output to MARWIN s5 on /dev/tty1b or /dev/ttya01. The lower half of figure 8 shows the software changes required. By comparing figures 4 and 5 with 8, the resulting design is cleaner and provides an improvement in the SMS data flow.

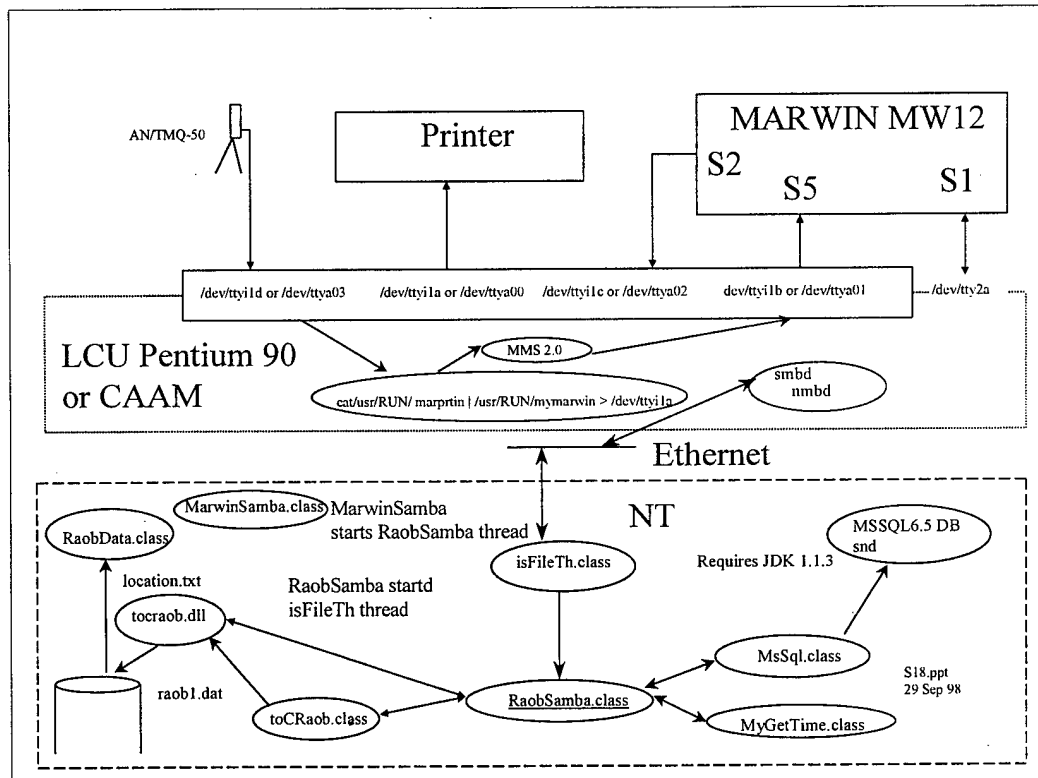

Figure 8. SMS and MARWIN data flow into SCO UNIX computer.

The hardware changes shown above require corresponding changes in the software. Because of the modularity of the system design, these changes are not great. For example, in figure 4, SMS data is received on COM3 by the MPS main (NT) computer and retransmitted to the LCU via COM4. In the revised design, this data is received by MPS Main via LAN from the LCU by means of a socket.

This requires code changes on both computers. The required C code for the LCU (Clientun.c) runs only 103 lines and is listed in appendix A. The corresponding code for MPS Main is a modified version of the JAVA code used in the MMS-P98 to forward the SMS data to the LCU. It has been modified from sending a file to receiving it. This code, Server.JAVA, is only 59 lines, and is listed in appendix B.

The situation with MARWIN data flow is very similar. The principal change on MPS Main is the replacement of the COM5 data flow with communication using a socket. The required software is very similar to that used for the SMS data. On the LCU side, the MARWIN data flow is shown in more detail below in figure 9.

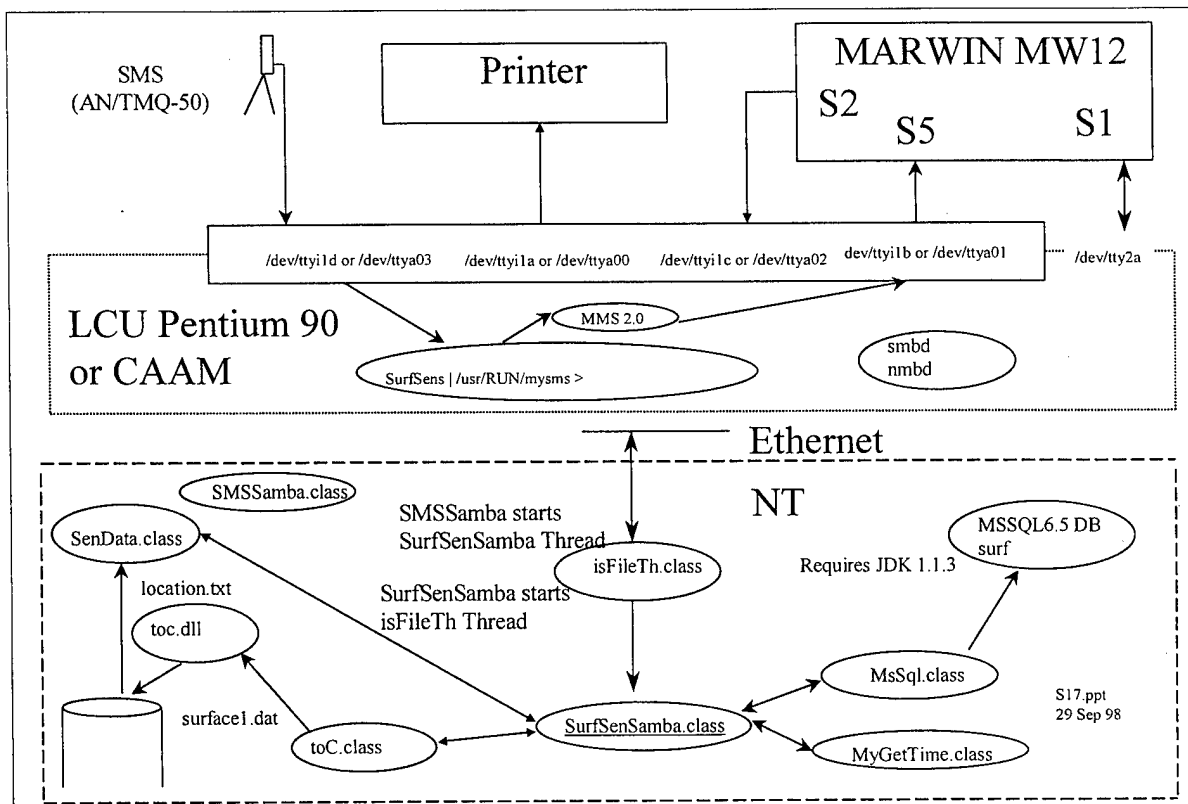

Figure 9. Data Flow from MARWIN to SCO UNIX computer.

The code required to send the data via LAN from the LCU to MPS Main is very similar to that used for the SMS data.

## 6.2 Radiometer Data Flow in the MMS-P (RV)

In the MMS-P98 design, the radiometer uses the eight-port module (Digi PC/8e) on the MPS WIN NT 4.0 Server (figure 6). The radiometer is physically connected to COM9 and COM10 on the Digi PC/8e. The rationale for this design was that the radiometer software will runs on the MPS WIN NT 4.0 Server.

The RV design exploits the fact that this is not required. The radiometer can be physically connected elsewhere (figure 10) and communicate with the software on the MPS WIN NT 4.0 over a pair of network sockets. Since it is being proposed that the MARWIN and surface sensor be connected physically to the LCU Pentium 90, the new design does the same for the radiometer. This move would eliminate the need for the Digi PC/8e on the MPS Main computer. This would eliminate a large number of cables and improve the data flow.

As was the case with SMS and MARWIN, only minor changes to the software are necessary to implement this change. Figure 10 shows the proposed changes to the radiometer data flow.

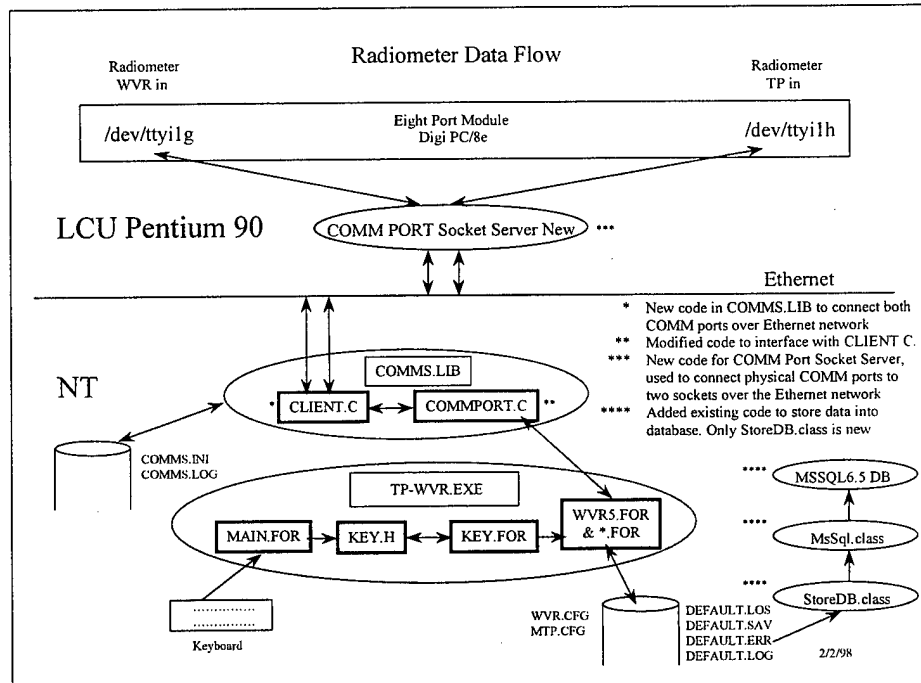

Figure 10. Radiometer data flow, proposed changes.

## 7.0 Combined LCU and CAAM/BFM Functions

In addition to the changes in port connections between figures 1 and 7, the other major change is lumping together in figure 7 of the CAAM/BFM and LCU computers. This reflects the system redesign to combine the functions of the LCU and the CAAM/BFM computers in a single system. This was necessary because the LCU lacked the capability to connect to the LAN. An additional crucial benefit was the reduction in the total number of computers required by one.

## 8.0 Remaining Issues

### 8.1 Connections and Interfaces

The elimination of the eight-port module from the MPS main computer leaves some unresolved issues, outlined below:

- The s1 connection between the MARWIN and the LCU is used to transfer the met messages to the LCU and for status information from the LCU to the MARWIN. The absence of this handshaking, which is not yet implemented on the LCU replacement, causes an alert on the MARWIN.
- The status of the LCU replacement's interface to the TCIM is still undetermined. The TCIM is the interface to the SINCGARS (radio) that transmits to and receives messages from other fire control systems.
- In the MMS, the s2 port of the eight-port module is used to print raob status and data during a flight. The status of this connection in the replacement LCU is not yet determined.

The dotted lines in figure 11 indicate the locations of the unresolved connections.

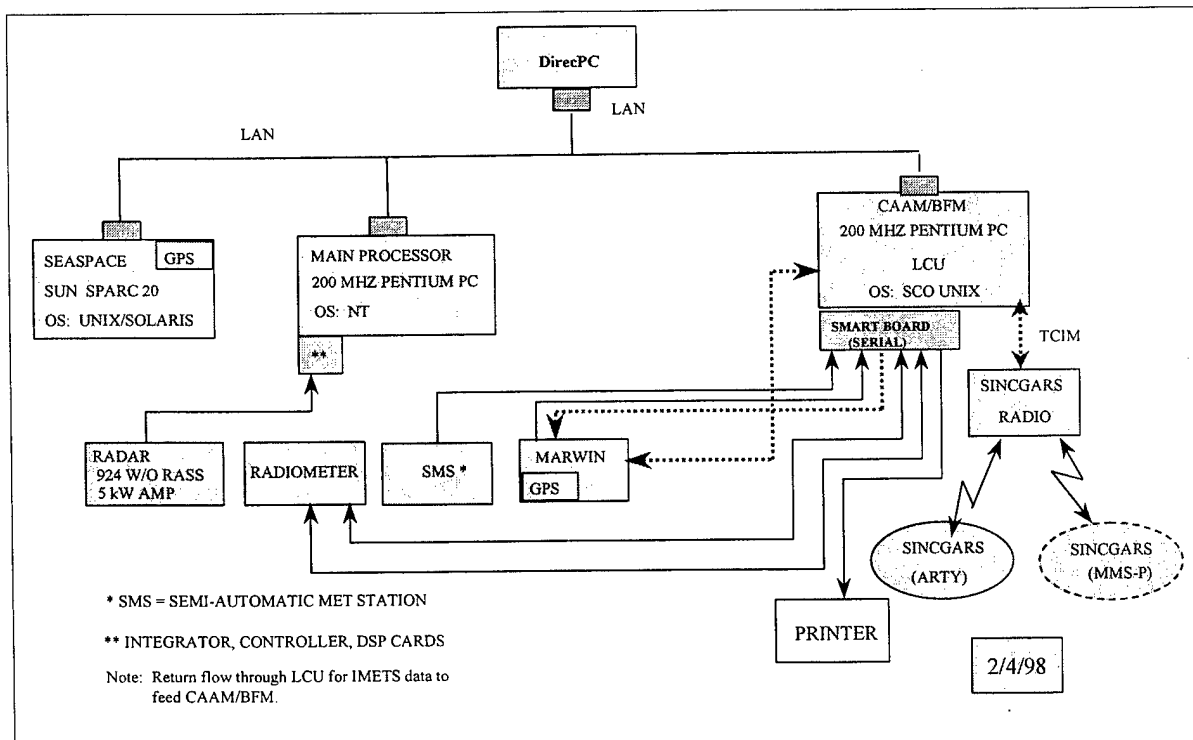

Figure 11. System connectivity, unresolved issues.

## 8.2 Data Transfer from SEASPACE Satellite System

Currently, the SEASPACE is using a file transfer protocol (FTP) method of transferring its data to the MMS-P. A method employing client/server sockets, like that used for radiometer, SMS, and MARWIN data is preferable for the SEASPACE also.

## 9.0 Conclusions

The lessons learned from operation of the system in the January test and subsequent analysis, resulted in a new design presented in this report. The new design reduces the hardware and simplifies of software interfaces. With the new design, the processes will run faster and will not interfere with the operation in the MMS mode, as was the case in the original design.

## References

1. Cogan, J., E. M. Measure, E. Vidal, E. Creegan, B. Weber, and D. Wolfe, "A Mobile System for Near-Real Time Atmospheric Soundings," In *Proceedings of the Second Symposium on Integrated Observing Systems*, American Meteor. Soc. Phoenix, AZ, pp. 57-59 11-16 January, 1998. (UNCLASSIFIED)
2. Cogan, J., E. M. Measure, and D. Wolfe, "Atmospheric Soundings in Near-Real Time from Combined Satellite and Ground-Based Remotely Sensed Data," *Journal of Oceanic and Atmospheric Technology*, Vol 14, pp 1127-1138, October 1997. (UNCLASSIFIED)
3. Cogan, J., E. Measure, E. Vidal, G. Vaucher, E. Creegan, B. Weber, D. Wolfe, "A HMMWV Based System for Near Real-Time Atmospheric Soundings Using Combined Satellite and Ground-Based Remote Sensing," In *Proceedings of the 1997 Battlespace Atmospheric Conference*, San Diego, CA, pp. 223-228, 2-4 December 1997. (UNCLASSIFIED)
4. Hogg, D. C., M. T. Decker, F. O. Guiraud, K. B. Earnshaw, D. A. Merritt, K. P. Moran, W. B. Sweezy, R. G. Strauch, E. R. Westwater, and C. G. Little, "An Automatic Profiler of the Temperature, Wind and Humidity in the Troposphere." *Journal of Climate and Applied Meteorology*, Vol. 22, May 1983, pp. 807-831. (UNCLASSIFIED)
5. Measure, E. M., Young P. Yee, Teddy L. Barber and Dick R. Larson, "Number of Non-Redundant Frequencies for Ground-Based Microwave Radiometric Temperature Profiling." *Journal of Atmospheric and Oceanic Technology*, 6, 5, pp. 846-850, October 1989. (UNCLASSIFIED)
6. Wolfe, D., B. Weber, D. Wuertz, D. Welsh, D. Merritt, S. King, R. Fritz, K. Moran, M. Simon, A. Simon, J. Cogan, D. Littell, and E. Measure, "An Overview of the Mobile Profiler System: Preliminary Results from Field Tests during the Los Angeles Free-Radical Study," *Bulletin of the American Meteorological Society*, Vol. 76, No. 4, pp. 523-534, April 1995. (UNCLASSIFIED)

7. Vidal, E., Jr., Miguel A. Suriano Jr., and Edward M. Measure, *Meteorological Measuring Set-Profiler Eight-Port Module Interface Design*, ARL-TR-1538, U.S. Army Research Laboratory, White Sands Missile Range, NM, July 2000. (UNCLASSIFIED)

# Acronyms

AFWA	Air Force Weather Agency
ARL	Army Research Laboratory
BED	Battlefield Environment Division
BFM	Battlescale Forecast Model
CAAM/BFM	Computer Assisted Artillery Meteorology/ Battlescale Forecast Model
CISD	Computational Information Sciences Directorate
DOS	Disc Operating System
FTP	File Transfer Protocol
GPS	Global Positioning System
HTTP	Hypertext Transfer Protocol
LAN	local area network
LCU	Army Lightweight Computer Unit
MMS	Met Measuring Set
MMS-P (RV)	MMS Profiler (proof-of-concept system, revised version)
MMS-P	MMS Profiler (proof-of-concept system)
MMS-P98	MMS Profiler (proof-of-concept system, version used in January 1998 test)
MPS	Mobile Profiler System
MSSQL	Microsoft Standard Query Language
NOGAPS	Navy Operational Global Atmospheric Prediction System
raob	rawinsonde observation
SCO	Santa Cruz Operation
SCSI	Small Computer System Interface

SINCGARS	Single Channel Ground and Airborne Radio System
SMS	Semi-automatic Meteorological Station
TCIM	Tactical Communications Interface Module
VECP	Value Engineering Change Proposal

Appendix A  
Clientun.c

```

#include <sys/types.h>
#include <sys/socket.h>
#include <netinet/in.h>
#include <netdb.h>
#include <stdio.h>
char DATA[1000];
/*#define DATA "sending data"*/
readmessg()
{
FILE *pt2;
int i;
char inputch;
i=0;
pt2=fopen("3230681.met","r");

while(fscanf(pt2,"%c",&inputch) != EOF)
{
DATA[i]=inputch;
/*printf("%c",DATA[i]);*/
i++;
}
/*printf("\ni=%d\n",i);*/
i++;
DATA[i]=0;
fclose(pt2);
}

/* This program creates a socket */

main(argc, argv)
int argc;
char *argv[];
{
int sdata;
char *adddata;
int sock;
struct sockaddr_in server;
struct hostent *hp, *gethostbyname();
char buf[1024];
int rval;
readmessg();

```

```

/* Create Socket */

sock = socket ( AF_INET, SOCK_STREAM, 0);
if ( sock == -1 )
{
    perror( "opening stream socket" );
    exit(1);
}

/* Connect socket using name specified by command line */

server.sin_family = AF_INET;
hp = gethostbyname( argv[1] );
printf("hostname = %s\n", hp->h_name);
printf("host_address_type = %d\n", hp->h_addrtype);
printf("h_length = %d\n", hp->h_length);
printf("host_address = %d\n", hp->h_addr);

pr_inet(hp->h_addr_list, hp->h_length);

/* gethostbyname returns a structure including the network address of the
specified host */

if ( (hp == (struct hostent *) 0 ) )
{
    fprintf( stderr, "%s: unknown host\n", argv[1] );
    exit(2);
}
memcpy( (char *) &server.sin_addr, (char *) hp->h_addr, hp->h_length );
server.sin_port = htons( atoi( argv[2] ) );
if ( connect( sock, (struct sockaddr *) &server, sizeof server ) == -1 )
{
    perror( "connecting stream socket" );
    exit(1);
}
adddata= &DATA;
sdata=sizeof DATA;
/* printf("%x %d\n",adddata,sdata);*/
if ( write( sock, adddata, sdata ) == -1 )
    perror( "writing on stream socket" );

if ( read( sock, buf, sizeof buf ) == -1 )
    perror( "reading stream socket" );

printf("%s\n", buf);

```

```
        close( sock );
        exit(0);
    }

pr_inet(listptr, length)
char **listptr;
int length;
{
    struct in_addr *ptr;

    while ( (ptr = (struct in_addr *) *listptr++) != NULL)
        printf("\nInternet address: %s\n\n", inet_ntoa(*ptr));
}
```

**Appendix B**  
**ServerList.java**

```

/*
# $Header:
\\EAGLE053\default\RCS\K\java\src\socket\ServerList.java,v 1.3
1998/02/03 19:42:52 administrator Exp administrator $
*/

import java.net.*;
import java.io.*;
import java.lang.*;

public class ServerList
{
    static RandomAccessFile in;

    public ServerList(int port) throws java.io.IOException
    {
        ServerSocket ss=new ServerSocket(port,1);
        System.out.println("started");
        /*
        System.out.println("Accepting connections on local machine " +
            ss.getInetAddress().toString() + " on local port "
            + ss.getLocalPort() + ".");
        */
        Socket conSock;
        InputStream sockinp;
        byte b[]=new byte[1024];

        conSock=ss.accept();
        sockinp=conSock.getInputStream();
        int bread;
        /*
        System.out.println("Connected to remote machine at " +
            conSock.getInetAddress().toString() +
            " on remote port " + conSock.getPort() +
            " using local port " + conSock.getLocalPort() + ".");
        */
        while(sockinp.available() > 0 )
        {

            System.out.print((char)sockinp.read());

        }

        in.close();
    }
}

```

```
public static void main(String a[]) throws java.io.IOException
{
    if(a.length < 2)
    {
        System.out.println("Usage: ServerList <port> <filename>");
        return;
    }

    in=new RandomAccessFile(a[1],"r");

    ServerList ser=new ServerList(Integer.parseInt(a[0]));
}
}
```

Distribution

NASA MARSHALL SPACE FLT CTR ATMOSPHERIC SCIENCES DIV E501 ATTN DR FICHTL HUNTSVILLE AL 35802	1
NASA SPACE FLT CTR ATMOSPHERIC SCIENCES DIV CODE ED 41 1 HUNTSVILLE AL 35812	1
US ARMY MISSILE CMND AMSMI RD AC AD ATTN DR PETERSON REDSTONE ARSENAL AL 35898-5242	1
US ARMY MISSILE CMND AMSMI RD AS SS ATTN MR H F ANDERSON REDSTONE ARSENAL AL 35898-5253	1
US ARMY MISSILE CMND AMSMI RD AS SS ATTN MR B WILLIAMS REDSTONE ARSENAL AL 35898-5253	1
US ARMY MISSILE CMND AMSMI RD DE SE ATTN MR GORDON LILL JR REDSTONE ARSENAL AL 35898-5245	1
US ARMY MISSILE CMND REDSTONE SCI INFO CTR AMSMI RD CS R DOC REDSTONE ARSENAL AL 35898-5241	1
US ARMY MISSILE CMND AMSMI REDSTONE ARSENAL AL 35898-5253	1
PACIFIC MISSILE TEST CTR GEOPHYSICS DIV ATTN CODE 3250 POINT MUGU CA 93042-5000	1
ATMOSPHERIC PROPAGATION BRANCH SPAWARSYSCEN SAN DIEGO D858 49170 PROPAGATION PATH SAN DIEGO CA 92152-7385	1
METEOROLOGIST IN CHARGE KWAJALEIN MISSILE RANGE PO BOX 67 APO SAN FRANCISCO CA 96555	1

NCAR LIBRARY SERIALS NATL CTR FOR ATMOS RSCH PO BOX 3000 BOULDER CO 80307-3000	1
HEADQUARTERS DEPT OF ARMY DAMI POI ATTN LEE PAGE WASHINGTON DC 20310-1067	1
MIL ASST FOR ENV SCI OFC OF THE UNDERSEC OF DEFNS FOR RSCH & ENGR R&AT E LS PENTAGON ROOM 3D129 WASHINGTON DC 20301-3080	1
DEAN RMD ATTN DR GOMEZ WASHINGTON DC 20314	1
US ARMY INFANTRY ATSH CD CS OR ATTN DR E DUTOIT FT BENNING GA 30905-5090	1
HQ AFWA/DNX 106 PEACEKEEPER DR STE 2N3 OFFUTT AFB NE 68113-4039	1
PHILLIPS LABORATORY PL LYP ATTN MR CHISHOLM HANSCOM AFB MA 01731-5000	1
PHILLIPS LABORATORY PL LYP 3 HANSCOM AFB MA 01731-5000	1
AFRL/VSBL 29 RANDOLPH RD HANSCOM AFB MA 01731	1
ARL CHEMICAL BIOLOGY NUC EFFECTS DIV AMSRL SL CO APG MD 21010-5423	1
US ARMY MATERIEL SYST ANALYSIS ACTIVITY AMSXY APG MD 21005-5071	1
ARMY RESEARCH LABORATORY AMSRL D 2800 POWDER MILL ROAD ADELPHI MD 20783-1145	1

ARMY RESEARCH LABORATORY AMSRL OP CI SD TL 2800 POWDER MILL ROAD ADELPHI MD 20783-1145	1
ARMY RESEARCH LABORATORY AMSRL CI LL ADELPHI MD 20703-1197	1
ARMY RESEARCH LABORATORY AMSRL SS SH ATTN DR SZTANKAY 2800 POWDER MILL ROAD ADELPHI MD 20783-1145	1
ARMY RESEARCH LABORATORY AMSRL CI ATTN J GANTT 2800 POWDER MILL ROAD ADELPHI MD 20783-1197	1
ARMY RESEARCH LABORATORY AMSRL 2800 POWDER MILL ROAD ADELPHI MD 20783-1145	1
NATIONAL SECURITY AGCY W21 ATTN DR LONGBOTHUM 9800 SAVAGE ROAD FT GEORGE G MEADE MD 20755-6000	1
US ARMY RSRC OFC ATTN AMXRO GS DR BACH PO BOX 12211 RTP NC 27009	1
DR JERRY DAVIS NCSU PO BOX 8208 RALEIGH NC 27650-8208	1
US ARMY CECRL CECRL GP ATTN DR DETSCH HANOVER NH 03755-1290	1
US ARMY ARDEC SMCAR IMI I BLDG 59 DOVER NJ 07806-5000	1
ARMY DUGWAY PROVING GRD STEDP MT DA L 3 DUGWAY UT 84022-5000	1
ARMY DUGWAY PROVING GRD STEDP MT M ATTN MR BOWERS DUGWAY UT 84022-5000	1

DEPT OF THE AIR FORCE OL A 2D WEATHER SQUAD MAC HOLLOMAN AFB NM 88330-5000	1
PL WE KIRTLAND AFB NM 87118-6008	1
USAF ROME LAB TECH CORRIDOR W STE 262 RL SUL 26 ELECTR PKWY BLD 106 GRIFFISS AFB NY 13441-4514	1
AFMC DOW WRIGHT PATTERSON AFB OH 45433-5000	1
US ARMY FIELD ARTILLERY SCHOOL ATSF TSM TA FT SILL OK 73503-5600	1
US ARMY FOREIGN SCI TECH CTR CM 220 7TH STREET NE CHARLOTTESVILLE VA 22448-5000	1
NAVAL SURFACE WEAPONS CTR CODE G63 DAHLGREN VA 22448-5000	1
US ARMY OEC CSTE EFS PARK CENTER IV 4501 FORD AVE ALEXANDRIA VA 22302-1458	1
US ARMY CORPS OF ENGRS ENGR TOPOGRAPHICS LAB ETL GS LB FT BELVOIR VA 22060	1
US ARMY TOPO ENGR CTR CETEC ZC 1 FT BELVOIR VA 22060-5546	1
SCI AND TECHNOLOGY 101 RESEARCH DRIVE HAMPTON VA 23666-1340	1
US ARMY NUCLEAR CML AGCY MONA ZB BLDG 2073 SPRINGFIELD VA 22150-3198	1
USATRADO ATCD FA FT MONROE VA 23651-5170	1
ATRC WSS R WSMR NM 88002-5502	1

ARMY RESEARCH LABORATORY AMSRL CI E COMP & INFO SCI DIR WSMR NM 88002-5501	1
DTIC 8725 JOHN J KINGMAN RD STE 0944 FT BELVOIR VA 22060-6218	1
US ARMY MISSILE CMND AMSMI REDSTONE ARSENAL AL 35898-5243	1
US ARMY DUGWAY PROVING GRD STEDP3 DUGWAY UT 84022-5000	1
USTRADOC ATCD FA FT MONROE VA 23651-5170	1
WSMR TECH LIBRARY BR STEWIS IM IT WSMR NM 88002	1
US ARMY RESEARCH LAB AMSRL D DR D SMITH 2800 POWDER MILL RD ADELPHI MD 20783-1197	1
US ARMY CECOM INFORMATION & INTELLIGENCE WARFARE DIRECTORATE ATTN AMSEL RD IW IP FORT MONMOUTH NJ 07703-5211	1
JAMES COGAN BRANCH CHIEF ARMY RESEARCH LAB AMSRL IS EA WSMR NM 88002-5501	1
ARMY RESEARCH LAB AMSRL IS EA ALFRED GUTIERREZ WSMR NM 88002-5501	2
ARMY RESEARCH LAB AMSRL IS EA EDWARD VIDAL JR WSMR NM 88002-5501	15
ARMY RESEARCH LAB AMSRL IS EA EDWARD MEASURE WSMR NM 88002-5501	7

ARMY RESEARCH LAB	1
AMSRL IS EA	
DAVID QUINTIS	
WSMR NM 88002-5501	
ARMY RESEARCH LAB	1
AMSRL IS EA	
GAIL VAUCHER	
WSMR NM 88002-5501	
Record copy	1
TOTAL	85