

# Civil Defense Research Project

## ANNUAL PROGRESS REPORT

*March 1971 - March 1972*

**DISTRIBUTION STATEMENT A**  
Approved for Public Release  
Distribution Unlimited



**OAK RIDGE NATIONAL LABORATORY**

OPERATED BY UNION CARBIDE CORPORATION • FOR THE U.S. ATOMIC ENERGY COMMISSION

Reproduced From  
Best Available Copy

DMIC QUALITY IMPROVED 4

20000914 058

Printed in the United States of America. Available from  
National Technical Information Service  
U.S. Department of Commerce  
5285 Port Royal Road, Springfield, Virginia 22151  
Price: Printed Copy \$3.00; Microfiche \$0.95

This report was prepared as an account of work sponsored by the United States Government. Neither the United States nor the United States Atomic Energy Commission, nor any of their employees, nor any of their contractors, subcontractors, or their employees, makes any warranty, express or implied, or assumes any legal liability or responsibility for the accuracy, completeness or usefulness of any information, apparatus, product or process disclosed, or represents that its use would not infringe privately owned rights.

Contract No. W-7405-eng-26

**CIVIL DEFENSE RESEARCH PROJECT  
ANNUAL PROGRESS REPORT  
March 1971–March 1972**

**CIVIL DEFENSE RESEARCH PROJECT  
Director's Division**

DECEMBER 1972

OAK RIDGE NATIONAL LABORATORY  
Oak Ridge, Tennessee 37830  
operated by  
UNION CARBIDE CORPORATION  
for the  
U.S. ATOMIC ENERGY COMMISSION

# Contents

Foreword .....	v
Summary .....	vii
<b>I. Urban Research</b>	
A. Urban Utility Technology	
1. Installation of Utilities by Common Trenching – <i>W. J. Boegly, Jr., and W. L. Griffith.</i> .....	1
B. Urban Growth Patterns	
2. An Analysis of Population Concentration and Dispersal in the United States, 1940–1970 – <i>R. A. Bohm and D. A. Patterson</i> .....	10
3. Interstate Highway Location and County Population Growth – <i>R. A. Bohm and D. A. Patterson</i> .....	16
4. How Cities Grow – <i>Everett S. Lee</i> .....	19
5. Growth of Urbanized Areas – <i>M. L. Levin and W. W. Pendleton</i> .....	24
6. Social Security Data and Urban Growth Patterns – <i>Kathryn P. Nelson</i> .....	32
7. Changes in the Concentration of Employment in Metropolitan Areas, 1964–1969 – <i>C. H. Patrick</i> .....	37
8. Blacks and Suburbanization in Atlanta – <i>W. W. Pendleton and M. L. Levin</i> .....	44
9. An Examination of Black Suburban Residence – <i>W. W. Pendleton and M. L. Levin</i> .....	47
10. The Fertility of Negroes without Southern Rural Experience: A Reexamination of the 1960 GAF Study Findings with 1967 SEO Data – <i>P. N. Ritchey</i> .....	55
11. The Intervening Effects of Marital Status on the Fertility of Rural-Urban and Urban-Rural Migrants – <i>P. N. Ritchey</i> .....	59
12. Race, Poverty, and Educational Achievement in an Urban Environment – <i>M. M. Williams</i> .....	64
<b>II. Civil Defense Systems Analysis</b>	
13. Analysis of Effects of Nuclear Weapon Overpressures on Hasty Pole Shelters – <i>C. V. Chester and         R. O. Chester</i> .....	67
14. Construction of Hasty Winter Shelters – <i>C. H. Kearny</i> .....	78
15. Blast Shelter Potential in New Government Buildings – <i>G. A. Cristy</i> .....	90
16. Active-Passive Defense in Detroit – <i>C. M. Haaland</i> .....	94
<b>III. Weapons Effects</b>	
17. Studies of Nuclear Electromagnetic Pulse (EMP) Effects on Power Systems – <i>J. K. Baird,         J. H. Marable, and D. B. Nelson</i> .....	102
18. Power Reactor Vulnerability – <i>R. O. Chester and C. V. Chester</i> .....	114
Publications .....	122

## Foreword

The ORNL Civil Defense Research Project was jointly sponsored by the Department of Defense and the Atomic Energy Commission during the first four years of its operation. During the past four years a portion of the research has been devoted to urban problems, under the sponsorship of the Department of Housing and Urban Development. The ongoing defense research has consisted of an interdisciplinary study of the problems of advanced civil defense systems which might be installed during the middle to late 1970's. This is the eighth and last of this series of progress reports. The following year's reports will be issued as part of the Health Physics Division Annual Report. The first<sup>1</sup> covered topics studied during the first six months of the project, and the second,<sup>2</sup> third,<sup>3</sup> fourth,<sup>4</sup> fifth,<sup>5</sup> sixth,<sup>6</sup> and seventh<sup>7</sup> covered topics during the next full years.

The eighth report contains the results of research in 16 areas related to urban problems and civil defense. The summaries of the individual chapters and the chapters themselves are introduced and related to each other in this report by following the format used in the previous reports, listing a series of 11 problems and comments or partial solutions related to either urban problems or the effectiveness of advanced civil defense, following the report's chapter sequence.

1. *Problem:* If underground urban utilities are installed simultaneously in a single trench, are there economic advantages which would favor more widespread use of the concept?

*Comment:* Experience in England suggests that economic advantages accrue when a "common trench" is used. There remain many administrative problems to be solved, as discussed in Chap. 1.

2. *Problem:* Can regularities in the population changes in U.S. counties be identified and explained?

*Comment:* Many states, particularly in the south and mountain areas, have been concentrating their populations for at least 30 years, as measured by county Lorenz curves; so has the nation as a whole. For a discussion of these trends, see Chap. 2. One recent development which may have long-term significance is the preferential growth of certain counties near new interstate highways. This trend is discussed in Chap. 3.

3. *Problem:* It is popularly believed that cities are growing larger and denser. Do the census data bear this out?

*Comment:* The percentage of the total population in urbanized areas greatly increased during the last 20 years. However, the average distances between people in these areas also increased. This seeming paradox is discussed in Chap. 4.

4. *Problem:* Population movement is said to be an "economically rational activity." What data sources are available to analyze employment shifts and migration?

*Comment:* The use of the Social Security 1% sample and the County Business Pattern data to measure the redistribution of workers is described in Chaps. 5 and 6.

5. *Problem:* Some popular writers have stressed black suburbanization as an important process which is breaking up the central city ghetto. Do the census data substantiate this movement?

*Comment:* It is relatively easy to show that more blacks live in the suburbs today than ever. It is much more difficult to show that it is an important movement which is modifying the ghettos or even that the new life in the suburbs is a substantial improvement over the old. These questions are discussed in Chaps. 7 and 8.

6. *Problem:* How does the movement from rural to urban environs affect fertility?

*Comment:* Previous studies indicated that both blacks and whites without previous southern rural experience had similar fertility. This conclusion is questioned in Chap. 9. In Chap. 10, the general effect of migration on fertility is discussed.

7. *Problem:* How important is poverty as an influence on educational achievement?

*Comment:* A sample of some 27,000 students attending St. Louis schools was studied to attempt to separate those variables associated with race from those with poverty. As Chap. 11 discloses, poverty seems much more important in determining school performance.

8. *Problem:* If an expensive U.S. strategic defense system were ever built — most unlikely in view of the SALT agreement — both blast shelters and missile defense would be presumably installed to protect urban

areas. How might such systems be combined to protect against short-warning (submarine-based) missiles?

*Comment:* Active defense to "hold off" an attack until the population has obtained shelter appears to be the optimum mix for Detroit, as described in Chap. 12.

9. *Problem:* If an inexpensive civil defense program in the U.S. were based on last-minute ("hasty") shelter construction outside target areas, are such structures resistant to blast? Can they be constructed in winter?

*Comment:* Open shelters have an inherent strength compared with closed shelters in that blast wave "filling" equalizes the forces on the roof. Such concepts are discussed in Chap. 13. Chapter 14 describes experiments on the construction of hasty shelters in the winter.

10. *Problem:* If the present program of dual-use shelters in urban buildings were expanded to a blast-slanting program in federal buildings, could a significant addition to the U.S. shelter needs be realized?

*Comment:* A small but significant addition can be made, as discussed in Chap. 15.

11. *Problem:* One nuclear weapons effect that has received little attention in the civil community is the electromagnetic pulse (EMP). It is said to have effects on power systems similar to that of lightning. But are conventional systems designed to cope with lightning adequate for EMP?

*Comment:* Probably not in many instances, as is discussed in Chap. 16.

## REFERENCES

1. *Civil Defense Study Group Progress Report, September 1964–March 1965*, ORNL-TM-1120 (classified).
2. *Annual Progress Report, Civil Defense Research Project, March 1965–March 1966*, ORNL-TM-1531, Part I; ORNL-TM-1531, Part II (classified).
3. *Annual Progress Report, Civil Defense Research Project, March 1966–March 1967*, ORNL-4184, Part I; ORNL-4184, Part II (classified); ORNL-4184, Part III (classified).
4. *Annual Progress Report, Civil Defense Research Project, March 1967–March 1968*, ORNL-4284, Part I; ORNL-4284, Part II (classified).
5. *Annual Progress Report, Civil Defense Research Project, March 1968–March 1969*, ORNL-4413.
6. *Annual Progress Report, Civil Defense Research Project, March 1969–March 1970*, ORNL-4566, Part I; ORNL-4566, Part II (classified).
7. *Annual Progress Report, Civil Defense Research Project, March 1970–March 1971*, ORNL-4679.

# Summary

## I. URBAN RESEARCH

### 1. Installation of Utilities by Common Trenching

With the advent of industrialized housing it becomes apparent that faster methods of utility installation will be required to ensure that occupancy of the housing can proceed as soon as possible. One possible approach that has been suggested is the installation of multiple utilities in the same trench. In this approach, excavation is minimized, and all utilities are installed at the same time. Limited attempts have been made using common trenches in the United States, and it has been found that technical problems are not as important as those involved with coordinated planning, design, and installation. In England a "working group" was set up to develop procedures for coordination. Their recommendations are analyzed in terms of United States experience, and recommendations are suggested for implementing common trenching in our country.

### 2. An Analysis of Population Concentration and Dispersal in the United States, 1940–1970

In this study Lorenz curves are constructed and Gini coefficients are computed for each state in the contiguous United States for 1940, 1950, 1960, and 1970. These curves and coefficients indicate that changes in the spatial distribution of the population are quite different among the various states. For the 30-year period, each state fell into one of four distinct groups: (1) states continuously centralizing, (2) states centralizing at a markedly decreasing rate, (3) states exhibiting no change in population concentration, and (4) states continuously decentralizing. A preliminary regression analysis for the 1950–1960 period indicates that the rate of population concentration is negatively related to population density, and positively related to employment in agriculture and mining, net in-migration, and the percent of population nonwhite.

### 3. Interstate Highway Location and County Population Growth

Interstate highways have exerted considerable influence on county population changes during the decade

1960–1970. Regionally, these effects appear to have been strongest in areas where past investment in highways has lagged, that is, the South Atlantic, East and South Central, West South Central, West North Central, and Mountain divisions. Interstate effects are also widespread in counties with extremely different urban characteristics. Interstate intersections apparently exert a powerful stimulus in counties with urban populations in the range 30,000 to 150,000. In counties with urban population less than 30,000, the effect of interstates on county population growth ranges from 6.1 to 41.6%.

### 4. How Cities Grow

In recent years population growth in cities has depended almost entirely upon annexation, about 98% of the total increase of central cities coming from this source in the last decade. In a few cities deaths to whites already exceed births, and this will be true of most of the Northeastern cities by the middle of this decade if present trends continue. Migration of blacks into the central city still continues, but this is more than offset by the heavy out-migration of whites. By and large these trends hold regardless of city size.

Even for places as small as 5000 population, annexation is an important source of growth. Except in the Northeast, 40% or more of the towns of 5,000 to 50,000 annexed territory during the last decade. In the Northeast, organization by towns has made annexation difficult, and is a major factor in the slow growth of cities and towns in that region. There were no annexations in five of the New England states. It appears that central business districts in even the small towns are being abandoned in favor of shopping centers and office buildings on the outskirts.

### 5. Growth of Urbanized Areas

To distinguish more accurately the urban from the rural population in the vicinity of large urban complexes or conurbations, in 1950 the Bureau of the Census introduced the concept of an *urbanized area*, comprised of a *central city* and an *urban fringe*. Defined according to sociologically rather than politically rele-

vant criteria, the urbanized area was designed as a statistical aggregate to be more reflective of the actual urban condition than previously employed concepts. Using urbanized areas to study the changing distribution of population in the conterminous United States, Alaska, and Hawaii from 1950 to 1970, the following trends were observed: The number of urbanized areas, their populations, and their land areas all increased between 1950 and 1970. Moreover, the percentage of the total population which inhabited these areas increased markedly over the same period. Consequently, despite the fact that the land area devoted to these urbanized areas nearly tripled since 1950, in 1970 nearly 60% of the total population of the country resided in the urbanized areas and on less than 1% of the land area of the country. At the same time, the distribution of population within the urbanized areas was itself changing, with relatively more and more persons inhabiting the urban fringes than the central cities. The bulk of the population growth of the urbanized areas, therefore, took place in the fringes. The bulk of the land area increase was also in the fringe; this factor, coupled with the redistribution of the urbanized population, caused the aggregate population density in the urbanized areas to decrease markedly from 1950 to 1970, especially in the central cities, where it fell from 12.2 to 7.0 persons per acre. During the same period the densities in the urbanized areas as a whole fell from 8.45 to 5.3 persons per acre. Urban fringe aggregate density fell from 4.9 persons per acre in 1950 to 4.1 persons per acre in 1960, where it remained constant to 1970.

#### 6. Social Security Data and Urban Growth Patterns

Because of its capacity for tracing individuals in the covered work force through both geographical and industrial movement, the Social Security One Percent Sample promises to be a valuable tool for the study of urban growth patterns. During the year data on those in covered employment in 1962 and in 1967 in the Standard Metropolitan Statistical Areas (SMSAs) of Atlanta, Cleveland, Philadelphia, St. Louis, San Francisco, and San Jose have been employed to study growth and change in metropolitan labor forces, the processes of labor mobility and spatial redistribution of employment within each SMSA, and migration streams of workers between an SMSA and the main geographical regions of the United States.

#### 7. Changes in the Concentration of Employment in Metropolitan Areas, 1964-1969

Shifts in the concentration of employment have been occurring in the United States since at least the turn of the century. These shifts in employment have exhibited two definite patterns: Employment in Standard Metropolitan Statistical Areas (SMSAs) has been dispersing into the suburbs from the core, and employment nationwide has been dispersing into the South and West from the Old Manufacturing Belt of the Northeast and Great Lakes regions.

Recent studies have shown the extent to which industry has been decentralizing. Studies by Creamer, ACIR, Mills, and Kain have shown that the suburbs have been growing at a much faster pace than the core of metropolitan areas. Creamer and the ACIR have also shown that industry has become less concentrated in the Northeast and more dispersed into the South and West.

Using County Business Pattern data for 1964 and 1969, changes in the concentration of total employment and manufacturing employment have been computed for 33 multicounty SMSAs. The data show that employment in both the core and suburban counties has grown, but in the suburbs employment has grown at twice the rate of that in the core. As a result, employment has become less centralized within metropolitan areas. When the data are examined by region, the Northeast is found to be the only region to have experienced a decline in its share of national employment, while the South experienced the largest increase in share. These results support those found in the earlier studies in that employment is becoming more dispersed both within metropolitan areas and among the regions of the United States.

#### 8. Blacks and Suburbanization in Atlanta

This chapter and the one that follows are devoted to the racial aspects of urban residence patterns. In this paper the central city and suburbs of Atlanta are examined to determine if there is any pattern of black suburbanization and whether such a pattern indicates that a consequence of black suburbanization is a reduction in black-white differences in demographic and socioeconomic characteristics. Though the findings are tentative because only part of the relevant census material is available, the major conclusions in the report are: (1) Though Atlanta is not typical of American

cities in this respect, blacks became a much smaller part of the suburbs between 1960 and 1970; (2) even so, the number of blacks in the suburbs did increase during that time; (3) both races show patterns of differences between the central city and the suburb, but the patterns are not the same; (4) the suburban ring is probably not an adequate definition of suburb in this case; (5) blacks do fare better in some cases where they are a small part of the neighborhood population, which indicates that early stages of integration, typical of suburban areas, might be associated with improvement in the conditions of blacks; and (6) at the same time, blacks are more crowded where they are least numerous, so additional measures of socioeconomic status must be employed before a final assessment of the problem is made.

### 9. An Examination of Black Suburban Residence

This chapter is a companion to Chap. 8. Focusing on the implications of suburban residence in ten cities, the results apply both to substantive questions of demographic and social differences and to the methodological issue of the definition of the suburb. Substantively, the report finds that the central cities and suburban rings of the selected cities vary greatly with respect to their racial mix, their relative proportion of the total population of the SMSA, and the differences between the races. Taking the cities as a group, evidence is found that a suburban factor or consistent differences exist between residents of the central city and the ring. This suburban factor, however, is not representative of the general idea of suburban life, because it is found with respect to demographic characteristics such as fertility and dependency rather than socioeconomic characteristics such as housing. Though the suburban factor extends to both races, racial differences are nearly as likely to be greater as smaller in the suburbs. The methodological issue of setting a geographic boundary on the suburb has not adequately solved the central city ring definition, because the ring represents a quite different part of the total SMSA in different places. The lack of a consistent pattern in the socioeconomic comparisons may be a result of that definition. Further analysis will allow other definitions to be tested and, in addition, perhaps will allow better-suited socioeconomic variables to be employed.

### 10. The Fertility of Negroes without Southern Rural Experience: A Reexamination of the 1960 GAF Study Findings with 1967 SEO Data

Since World War II only one study has examined the fertility of black and white rural-urban migrants and their indigenous urban counterparts – the 1960 *Growth of American Families Study* (GAF). A major finding was that whites and blacks without southern rural experience had similar fertility. The implications of this finding were that: (1) The high youth dependency burden was not characteristic of blacks who were indigenous urbanites and (2) as social and economic equality for blacks becomes realized, they may in fact have lower fertility than that of whites.

This paper reports on a reexamination of the GAF study finding with a substantially larger black sample. Data from the 1967 *Survey of Economic Opportunity* (SEO) demonstrated that the residence background classification utilized in the GAF study defeated, in part, the attempt to remove the effects of rural experience on fertility. The SEO data indicated indigenous urban blacks had 25% higher fertility than indigenous urban whites, contradicting the GAF study finding. The fertility of urban black migrants out of the rural South was sharply curtailed in contrast to those remaining in the rural South. Although urban blacks of southern rural background had nominally higher fertility than indigenous urban blacks, the difference was not substantively significant.

These data suggest that a high youth dependency burden, with its resultant limitations on social and economic mobility, is characteristic of all urban black couples and not simply an attribute of in-migrants from the rural South. Furthermore, as the influence of southern rural patterns of mating and childbearing diminishes, the white-black fertility differential will decline, as suggested by the authors of the GAF study. However, other factors, in addition to those associated with rural background, must be sufficiently altered before the white-black differential in fertility ceases to exist.

### 11. The Intervening Effects of Marital Status on the Fertility of Rural-Urban and Urban-Rural Migrants

Existing knowledge on the relationship between migration and fertility has been based on studies of

married women. Furthermore, research has focused on the fertility of rural-urban migrants and has tended to ignore fertility among urban-rural migrants. These two factual gaps have limited assessment of the contribution of the fertility of migrants to population growth and the urban-rural differential in fertility.

This paper reports on an analysis of data from the national 1967 Survey of Economic Opportunity. The major objective of the study was the determination of the intervening effects of marital status on the relation between migration and fertility.

Among white married women 20 to 44 years of age rural-urban migrants have only slightly higher fertility than that of indigenous urban women, thereby serving to slightly increase the rate of population growth in urban areas. Urban-rural migrants, on the other hand, have lower fertility than indigenous rural women and consequently serve to dampen the growth rate in rural areas. The relative effect upon the growth rates at place of destination is greater for urban-rural than for rural-urban migrants.

When the analysis is not restricted to married women, the impact of migration of both urban and rural fertility is considerably changed. In general, migrants were more likely than indigenous sending and receiving populations to have been ever married and to be married and living with spouse — including being either in a sustained first marriage or being remarried.

Proportionately more migrants and less indigenous women bear children. Therefore, when we examine fertility of all women, irrespective of marital status, the childbearing of rural-urban migrants makes a moderate contribution to increasing the rate of population growth in urban areas. In rural areas, when the marital status classification of women is ignored, the presence of urban-rural migrants acts more to sustain the rate of rural population growth — partially offsetting the lowering effect of the fertility of the rural indigenous women.

## 12. Race, Poverty, and Educational Achievement in an Urban Environment

The independent and interacting effects of poverty and race on academic achievement were examined for all 4th through 6th grade children attending public neighborhood schools in St. Louis, Missouri between Fall 1968 and Spring 1971 (N = 27,465). Analysis of grouped data, based on Iowa Tests of Basic Skills mean composite scores, showed that when neighborhood poverty levels were similar there was no practical difference between the achievement of black and white

children. Regression analysis of ungrouped data showed that poverty as an independent variable was related to a much larger decrement in achievement than was race.

The results suggest that racial differences in achievement are more related to environmental-economic inequalities than to genetic differences. Compensatory education for the poor must therefore involve neighborhood and family economic improvement, as well as improvement of the school environment.

## II. CIVIL DEFENSE SYSTEMS ANALYSIS

### 13. Analysis of Effects of Nuclear Weapon Overpressures on Hasty Pole Shelters

Open hasty shelters, similar to those described in Russian civil defense manuals, were analyzed for (1) the transient internal pressures and (2) the dynamic response of the roof. The transient internal pressure will exceed the external pressure as the external pressure falls. If this excess, called differential shelter overpressure (DSOP), is greater than about 0.13 atm (2 psi), the possibility exists of lifting the earth-covered roof off the shelter.

The analysis showed that for shocks of 2 atm or greater this critical pressure is exceeded for large values of the ratio of shelter volume to the product of entrance area and positive phase duration. For incident shocks of 1 atm or less, the negative pressure on the roof never exceeds 2 psi. It was discovered that reflected shocks from nearby obstacles reaching the shelter entrance during the decay of the initial overpressure cause a dramatic increase in the observed peak DSOP.

The response of the roof to the initial positive (downward) pressure was estimated by assuming that the stress-strain curve of the green hardwood poles supporting it could be approximated by an elastic-plastic member with a yield stress of 8000 psi and ultimate strain six times yield strain. Tests on poles supported these assumptions. It was discovered that an open shelter of interest will survive some 50% more overpressure (22 psi) from 200-kiloton weapons than the same shelter with closed doors (15 psi).

### 14. Construction of Hasty Winter Shelters

If a major crisis were to escalate in the wintertime, millions of Americans might be able to improve their chances of surviving if they were given provenly practical instructions for building hasty winter shelters — above-ground types covered with snow and below-

ground types dug through frozen earth. However, no records were found of any hasty winter shelters having been built in the United States.

Therefore, the following designs (based mainly on Russian descriptions of winter shelters) were built in February and March 1972 in the Colorado Rockies by workmen using hand tools, chain saws, and a D6 bulldozer:

*Above-ground snow-covered types:* (1) Log-Tepee Shelter (30-man, 2.6 man-hours per occupant space); (2) Ridgeway Shelter, with a rectangular small-pole shelter attached (23-man, 3.0 man-hours per space); (3) A-Frame Log Shelter (all work done by hand except for bulldozing a snow cover onto the shelter, 10-man, 4.8 man-hours per space).

*Below-ground types dug through frozen earth:* (1) One-Meter-Wide Log-Covered Trench Shelter (5-man, 5.6 man-hours per austere space); (2) Wire-Catenary Roofed Shelter (6-man, 7.7 man-hours per austere space); (3) Wide Bulldozed Log-Covered Shelter (14 ft wide, 450 ft<sup>2</sup>; unfurnished: 45-man, 3.0 man-hours per space; furnished with benches and overhead bunks: 60 spaces, 4.2 man-hours per space).

Improved methods for manually digging through frozen earth and for placing explosives within frozen earth are described, as is preliminary work on some habitability problems of hasty winter shelters.

### 15. Blast Shelter Potential in New Government Buildings

A survey was made of the building programs of the major federal agencies to locate and identify below-ground floor space in buildings in the design or early construction phase. Data were collected and analyzed to evaluate the potential for upgrading the federal civil defense shelter program through blast slanting of all new government buildings. Assuming that the building programs of the federal agencies for the next decade would follow the same pattern that existed the last five years as regards location, size, and type of construction, the result would be the production of only three-fourths of a million blast shelter spaces during the decade. If the slanting could be done for \$60 per shelter space, this represents a differential cost of \$4.5 million per year (less than 1% of the federal building construction budget each year).

The survey assembled and displayed data on geographic location, construction cost, and blast slantable spaces in 87 federal government buildings being designed and/or built by the General Services Administration, the Veterans Administration, and the Atomic

Energy Commission. The geographic locations of these buildings were examined in comparison with data from previous studies. It was found that except for a few locations in the center of very large cities, the potential shelter spaces in federal buildings located by this survey would provide shelter space to populations that would not already have been provided blast shelter space by the earlier proposed programs of utilizing PV 71-81 shelters and blast slanting of transportation structures.

### 16. Active-Passive Defense in Detroit

Movement to shelters at locations found by Bechtel Corporation for the inner city of Detroit was analyzed on a block-by-block basis for the 1970 residential population. The average distance per person to shelter was found to be about 1400 ft. An equivalent shelter spacing was extrapolated to the entire Detroit SMSA, and tradeoffs were investigated for the most cost-effective balance of passive and active defense. Three different shelter postures were assumed, and at various hardnesses, against a wide range of attacks by concentrated forces of submarines firing missiles with nuclear warheads. The active defense was assumed to consist of perfect interceptors engaged in terminal defense only. The most cost-effective defense was found to be a mix of modest-sized shelters, with capacities not exceeding about 200 spaces, combined with active defense which acts to hold off the attack until people can arrive at their shelters. The best shelter posture corresponds to an average distance per person to shelter in the inner city of Detroit of about 400 ft; hence, the spacing used for determining the locations for the Bechtel survey would be too great for protection against an SLBM attack.

## III. WEAPONS EFFECTS

### 17. Studies of Nuclear Electromagnetic Pulse (EMP) Effects on Power Systems

The ability to calculate EMP-induced surges on transmission lines has been extended by advances both in computational techniques and in modeling of components. Voltage and current surges so calculated have been used to analyze the effects of EMP on power distribution systems.

Advances in the computational techniques and modeling include a Gaussian frequency-to-time transformation, a generalized geometric description of the incident

pulse, its polarization, and the line configuration, a frequency-dependent ground reflection for all polarizations, the inclusion of resistance in ground and wire, and transformer-equivalent circuits which include frequency-dependent flux penetration. Using these methods, currents and voltages for a number of typical situations have been calculated.

These EMP-induced currents and voltages have been applied to the study of EMP effects on a typical substation. The protection offered by lightning arresters, in particular, has been taken into account. The resulting effects on insulators, bushings, and transformers are then considered. It is concluded that the substation is protected against "weak" EMP, that is, pulses with peak voltages less than the station basic

insulation level. But pulses of higher peak voltages remain problematical.

### 18. Power Reactor Vulnerability

Nuclear weapon damage to an LMFBR is divided into three classes. The most direct hit promptly ejects the core, and the results of this class have been previously reported. A less-direct hit that produces overpressures greater than 20 psi will result in an uncontained core meltdown. Realistic meteorological data from the Oak Ridge area are used to estimate the resultant downwind doses. Compared with the weapon effects, the meltdown does not produce significant additional casualties.

# I. Urban Research

---

## A. Urban Utility Technology

### 1. Installation of Utilities by Common Trenching

W. J. Boegly, Jr.      W. L. Griffith

#### 1.1 INTRODUCTION

During the past year research has been conducted on the use of common trenching practices in the United States. It appears from this study that common trenching is not in widespread use in this country, and, furthermore, where it is being used only two or three utilities are included. Technically, there appear to be few deterrents to the general application of common trenching; however, institutional and coordination problems appear to limit its use.

In December 1966 the Advisory Committee on Co-ordination of Underground Services was set up by the Ministry of Public Building and Works (Great Britain) to study the problem of "co-ordinating the installation of underground distribution mains and service connections with the construction of the buildings to be served." As a result of their studies two reports have been published listing their interim recommendations on common trenching and coordination management.<sup>1,2</sup> Using the interim recommendations an analysis has been made to determine the applicability of their system to United States practices and to identify areas where additional information would be required to define a United States system. Although the main thrust of the British analysis was to public housing, consideration was also directed to the private sector of the housing market.

#### 1.2 THE PROPOSED ENGLISH COMMON TRENCH

According to the report of the Technical Study Group,<sup>1</sup> the need for greater coordination in utility

installations has been brought about by three major developments: (1) Increased use of housing layouts based on vehicle/pedestrian segregation; (2) increased use of industrialized housing methods; and (3) increased use of machinery in the construction process. Of these, the first reason was indicated as most important. Reduced costs did not appear to be a factor in their considerations, although they do mention faster occupancy of housing and reduced construction time.

Vehicle/pedestrian separation produces housing developments in which roads do not normally penetrate the housing areas, and footpaths (sidewalks) are provided to allow movement between housing units and stores, schools, etc. Also, in these types of developments where high densities of inhabitants are desired, the housing may be so close together that the only places to install utilities would be under the footpaths between the buildings. As a result, repeated excavation in the confined space may cause damage to utilities already installed. Thus, common trenching appears to be highly advantageous for these types of developments.

#### 1.2.1 Trench Design

The recommendation of the Technical Study Group was that a stepped trench be used because this configuration allows both vertical and horizontal separation, and will facilitate crossovers at intersections. Their typical stepped trench is shown in Fig. 1.1. Also shown in this drawing are alternative locations if the telephone is laid in duct, and the suggested location for high-voltage electrical cables if they are present. It can be seen from the figure that sewers are not included in the common trench, but are deliberately segregated

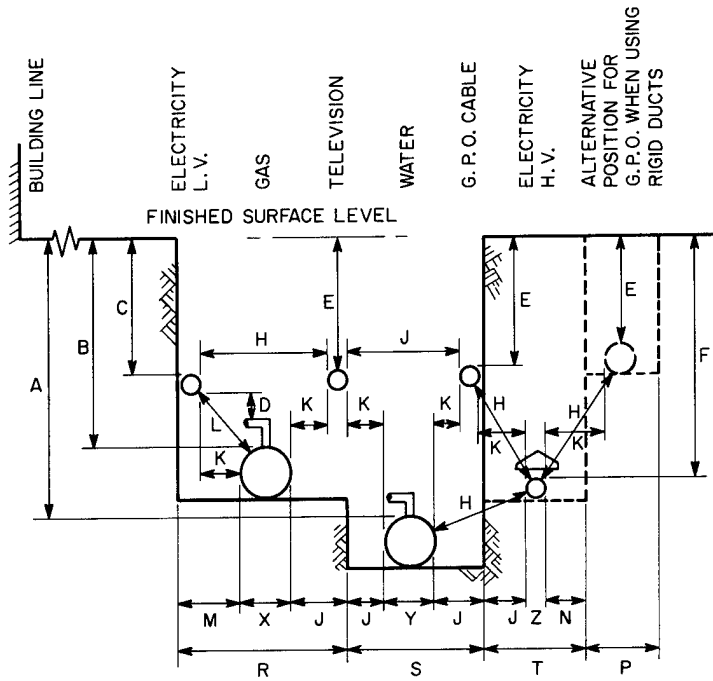

LETTER	DIMENSION		REMARKS
	BRITISH	METRIC	
	(ft) (in.)	(mm)	
A	3 0 min	900 min	
B	2 0 min	600 min	
C	1 6	450	
D	6 min	150 min	WITHOUT ADDITIONAL INSULATION
E	1 2 min	350 min	
F	2 6	750	
H	1 0 min	300 min	DISTANCE OF H.V. CABLE FROM G.P.O. REFERS TO MULTICORE CABLE ONLY.
J	6 min	150 min	G.P.O. REQUIRE CLEARANCE OF 1ft 6in. FROM SINGLE CORE H.V. CABLE.
K	4 min	100 min	
L	8 min	200 min	
M	9 min	250 min	WHEN L.V. INCLUDED, OTHERWISE 6 in. min (150 mm)
N	5 min	150 min	
P	9 min	250 min	
X	VARIABLE	VARIABLE	GAS PIPE OUTSIDE DIAMETER
Y	VARIABLE	VARIABLE	WATER PIPE OUTSIDE DIAMETER
Z	VARIABLE	VARIABLE	H.V. CABLE OUTSIDE DIAMETER

$R = M + X + J$

$S = 2J + Y$

$T = J + N + Z$

Fig. 1.1. Proposed joint trench.<sup>1</sup>

because of grade considerations and because the optimum routing of the sewers may not coincide with the routing of the common trench.

### 1.2.2 Installation

Cables and pipes are installed at specified depths and with definite spacing in the trench to meet recommended safety and operational practices. The recommended procedure in installation and backfill is illustrated in Fig. 1.2. The water line is the first utility to be placed in the trench. Once it is placed it is tapped and surrounded with selected backfill for protection, followed by stage 1 backfilling by the trenching contractor. The gas line is then installed, tapped, service connection made up, and the main and connections surrounded with special backfill. If high-voltage electric cables are present they are installed and protected at this stage. Stage 2 backfilling is then done by the trenching contractor to the level at which low-voltage electric, telephone, and television cables are to be laid. Service connections are made, and the trenching contractor completes the final backfill. Because of the need for junction boxes, valve pits, fire hydrant connections, etc., a zone 2 ft on each side of the main trench was designated as a "pink zone" or an area reserved for these auxiliaries.

Since the procedure for installing the utilities in the common trench is rather complicated, the Technical Study Group recommended that a single contractor or a composite work force be employed. This will be discussed in more detail later in this report.

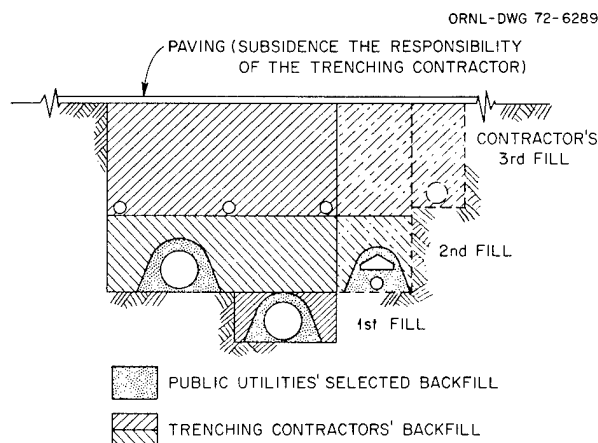

Fig. 1.2. Backfilling sequence.<sup>1</sup>

### 1.2.3 Service Connection

Coordination of the installation of distribution mains in a common trench is only one part of the problem. Service connections to the housing units remain to be completed. It was recommended that the service connections be completed at the same time the mains in the distribution system are installed. This, of course, assumes that the locations of the housing units are known or that the foundations have been installed. They describe a number of ways that this can be done, ranging from the use of temporary service terminals adjacent to the buildings to a common service pedestal in which all utilities would terminate.

### 1.2.4 Relation between Housing and Utility Construction

The visualized construction sequence would be as follows. First the sewers and roads would be installed to open up the site for the builders, and grading would be carried out for the foundations and the footpaths. Then the house foundations would be built and the sewer connected. At this point the common trench for the mains and service connections would be excavated, the lines installed and connected, and the trench backfilled. Finally, the housing would be completed, the footpaths and landscaping completed, and internal house connections made. As can be seen, it will be necessary for the developer to phase his building schedules into the utility schedules to ensure success. As a result he can complete his housing without concern for further excavation limiting his working space. However, coordination and cooperation to a very high degree will be required.

### 1.2.5 Recommendations of the Advisory Committee on Co-ordination Management<sup>2</sup>

#### Recommendation 1.1:

"The design of service connections and entry points and meter reading portions should be coordinated for individual dwellings respective of the number of dwellings involved."

#### Recommendation 1.2:

"Co-ordination of the installation of distribution mains should be considered on any building project of sufficient size to require new road works."

*Discussion.* In their discussion leading up to this recommendation the Study Group recognized four separate areas or stages of coordination. These ranged

from design coordination to coordination during the construction and installation phases. Evaluation of case studies on coordination pointed out three types of difficulties: (1) failure to notify utilities early enough; (2) failure to pass on agreements reached during design stages to on-site liaison; and (3) the developer would have to deal with public utilities as well as contractors dealing directly with him on roads, sewers, district heating, etc.

Also, the coordination problem is different in terms of whether the housing was developed by private or public organizations. The group felt that the private sector had a tendency to build more conventional layouts, whereas the public sector was tending toward complete vehicle/pedestrian segregation, and also that use of industrialized housing was more common in public housing and construction was normally faster. However, they felt that while the problems of coordination were being worked out on the whole project the least thing that could be done is to coordinate the service connections at the dwelling unit, regardless of the size of the development. If the project required new roads, they felt that any utilities that might be contained in these roads should also have coordinated design and installation.

**Applicability to the United States.** Many of the same problems occur in the United States in private and public developments. However, in the case of public developments in the United States, there appear to be additional problems since there are many forms of public developments. In our studies we have not found concern for the necessity of coordinating service connections. Although service connections are a significant problem, there has been little emphasis on installation by common trenching. Recommendation 1.2 appears to the authors to be the main area where common trenching has been attempted in the United States. From contacts with utility people it appears that the major problem is that the developer does not let the utilities know his needs early enough to allow the necessary coordination, and, furthermore, that the exact location and plan of the housing are subject to greater fluctuation than that envisioned in the English system.

**Recommendation 1.3:**

“The developer should accept responsibility for coordination from inception to completion of a project.”

**Recommendation 1.4:**

“In the absence of overall co-ordination by the developer, arrangements to achieve co-ordination

made by the main building contractor and the public utilities should be encouraged.”

**Recommendation 1.5:**

“Within the limits of an agreed program the co-ordinator should have program control of activities on site during the construction period.”

**Discussion.** Evaluation of case studies indicated that the necessary coordination can be obtained in three ways. First, the developer may choose to handle this function himself. Second, the building contractor can take the initiative. It is reported that this is the most common form, but usually involves only the contractor informing the utilities when they are able to work at the site. Finally, the utilities themselves can take the initiative.

In any case, it became evident to the Management Study Group that the necessary coordination could only be achieved if initiated at the inception of the project and carried out until the project was completed. They also felt that the most logical candidate for coordinator would be the developer, although they indicated that responsibility for day-to-day coordination could probably be delegated to the building contractor once the program of coordination had been agreed to. Finally, they emphasized that the following four points should be given serious consideration in planning the coordination program.

1. Layout design should be frozen.
2. The developer should not delegate responsibility for coordination to the building contractor until the entire coordination program has been settled.
3. The developer should not delegate responsibility for coordination until a definite system of communication has been established.
4. The developer must be ready to resume coordination at the request of any of the parties when difficulties arise.

**Applicability to the United States.** Based on our observations of U.S. practices, it appears that most developers do not appear anxious to assume the degree of coordination implied in the English system. The utilities do not appear to be in a position to do this either, since most of them are not involved in preplanning states and in many cases are not called in until the project is well under way. In fact, in many cases locations and sizes of buildings are not fixed until development is under way, which severely limits the possibility of coordinated planning by the utilities.

Instances have been reported where utilities have joined together on their own initiative to use a common trench.<sup>3-6</sup> However, pressure from developers or building contractors does not appear to be a factor in their decision. Rather, they appear to have approached the concept on the basis of reduced excavation and, hopefully, cost.

The developers of Foster City, California, attempted to install a coordinated utility system.<sup>7</sup> To do this they hired an electrical engineering firm as the coordinating agency. Detailed drawings were prepared showing the exact location of each service connection for each residential lot. Unfortunately, common trenches were not used extensively for all of the utilities.

**Recommendation 1.6:**

"The developer should limit the number of separate contracts under his direct control operating concurrently on site."

**Recommendation 1.7:**

"Pairing (twin trenching) for pipe and cable distribution mains respectively should be encouraged in cases where such arrangements are already in existence, where all the public utilities provide a full distribution system, and where the site layout is suitable."

**Recommendation 1.8:**

"Where common trenching is proposed, consideration should be given to the employment of a multi-skilled gang to establish, as a result of experience, whether these conditions are most likely to provide for trouble-free working on site."

**Recommendation 1.9:**

"Competitive rates for common trenching excavation work can be obtained under the main building contract by including the work in a supplementary bill of quantities, or by indicating in the invitation to tender documents that the successful tenderer will be invited to negotiate rates with the public utilities."

**Recommendation 1.10:**

"The multi-skilled contractor to carry out all work for the public utilities may be employed:

- (a) as a nominated sub-contractor under the terms of the main building contract;
- (b) by direct negotiation between the builder and the public utilities;
- (c) by one public utility on behalf of the rest."

**Recommendation 1.11:**

"Where day to day program coordination is to be delegated to the main building contractor it is desirable for a direct contractual relationship to exist between the developer or the main building contractor on the one hand and the public utilities on the other."

**Discussion.** The Management Study Group recommends that the number of contracts under the developer's control be limited in the interest of ease of coordination. Examples cited were to combine the road and sewer contract, and furthermore to make this a subcontract under the main building. If district heating, television, or piped fuel lines are included in the project, they should also be subcontracts under the main building contract.

If true common trenching cannot be achieved because of site limitations or if pairing arrangements already exist, consideration should be given to pairing of cables or pipes as a recommended method of installation. In this fashion the building contractor may be able to reduce the number of contracts.

Finally, it is proposed that a multidiscipline installation crew be used to handle the entire installation. However, labor problems with a crew drawn from various utility organizations might dictate the need to employ a separate contractor who would be responsible for the installation. It is felt that, in addition to economies from common use of labor and equipment, a reduction in the number of site visits and greater flexibility in operation would result.

The types of organizational structure described above are illustrated in Fig. 1.3.

Because of the amount of excavation related to utility installation vs that normally required in housing developments, the Management Study Group recommends that the main contract include provisions for excavating and backfilling the utility trenches. In this manner they feel that lower unit costs will result. If this is not satisfactory they recommend that the main contract have a clause allowing the builder the right to negotiate with the utilities for excavation and backfill.

If a multiskill contractor is elected to perform the installation, the main contract can have provisions for installation by a subcontractor if the cost of the work has previously been agreed to by all parties, or the main contract can have provisions to allow the successful bidder to negotiate rates with the utilities and, if successful, to contract with the utilities to do this work, or, finally, the utilities themselves can negotiate with an underground service contractor to do the work.

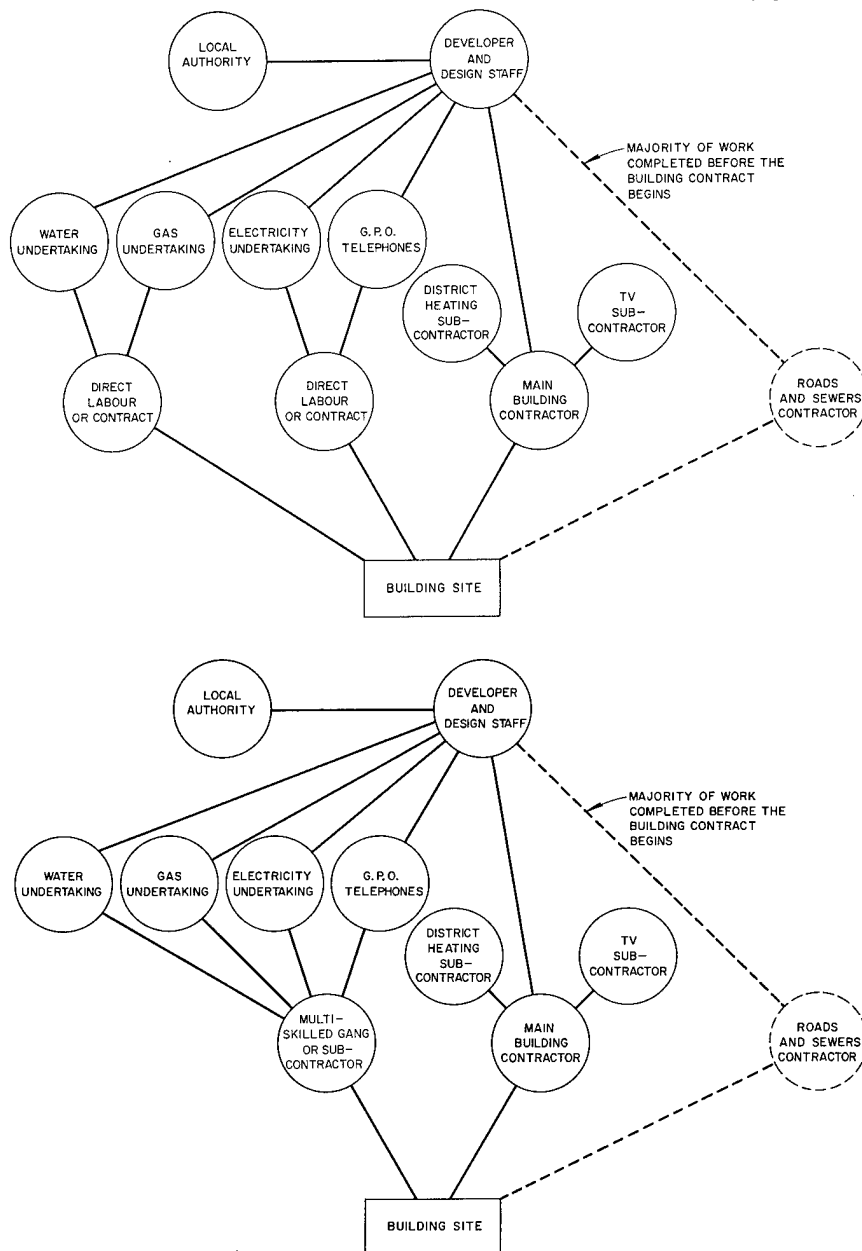

Fig. 1.3. Organizational arrangements. Upper, use of "pairing"; lower, use of multiskilled gang or contractor.

*Applicability to the United States.* Instances have been found in U.S. practices where certain of the features described above have been put into practice. In Illinois, Commonwealth Edison and Illinois Bell Telephone Company for a number of years have used the same crew to install both electric and telephone distribution systems in a common trench (pairing).<sup>8</sup>

This has been accomplished because both installation crews belong to the same union. In the case of Commonwealth Edison, their contractual agreement with the union allows them to contract out the work, but Bell Telephone cannot.

An example of coordinated design and construction of multiple utilities by a single coordinator exists in

New York City, where a new Police Headquarters building was constructed.<sup>9</sup> Under a single contract an engineering firm was employed to determine locations of existing utilities, determine placement of new utilities, schedule the work, prepare plans and specifications, and oversee the installation. The utilities agreed to deposit sufficient funds to cover their share of the cost. Each deposit was later adjusted on the basis of the bid prices and the actual costs of the work.

*Recommendation 1.12:*

"The initiating authority, be it the developer, builder or public utility laying the deepest main should accept interim financial responsibility and make appropriate service charges to cover administrative expenses when apportioning costs amongst those participating."

*Recommendation 1.13:*

"Costs for earth moving should be apportioned on the basis of the simplest formula which produces a fair result for the ground conditions concerned."

*Discussion.* The Management Study Group felt that it was not considered necessary to establish the financial attraction of each scheme by a complete cost-benefit analysis, although they did state that coordination would be most easily justified if the scheme were seen to be financially attractive to all parties participating. It was their feeling that when coordination was poor money was lost through damage, delays, and administrative costs in settling claims and arguments.

Cited by the Management Study Group as advantages of coordinated schemes were: "The ability to ensure greater accuracy of line and level, reduced interference from other mains-laying operations, the reduction of administrative costs for settling disputes, etc." It was pointed out that it is difficult to convert these advantages into financial terms.

In England, when the work is being executed under the terms of the main building contract, it appears that the developer normally arranges to make interim financial arrangements to cover payments to the utilities as work progresses. If one utility acts on the behalf of others they would provide this function. The Management Study Group apparently felt that since the utility having the deepest main would be the first to use the common trench they should be the one to accept the interim financial responsibility.

Three methods were proposed for allocating the costs in common trenching. The two preferred methods were based on volume per unit length of combined trench, or on the basis of costs which would be incurred by each

utility on the basis that its facilities were installed in an individual trench using standard cross sections. The third, and most elementary approach, adopts a formula of one share of cost for a cable and two shares for a pipe.

In addition to the recommendations listed above, the Study Group considered other financial aspects which inhibit coordination but felt that recommendations were not necessary since there were ways in which these items could be handled. The first of these is the early ordering of materials. Because the utilities indicated that shortages of material present no problem, and since the water utility can arrange for loans to cover needs for one year's work, it was felt that early ordering was not necessary. On the subject of unproductive mains, the Group felt that this could be handled best at the local level when negotiating commercial agreements for supplies. They also felt that the delay in revenue might be offset by reduced installation costs, or that the developer might be willing to accept some portion of the financial consequences arising from the initial lack of profit to ensure a minimum of disruption during the construction process. Finally, they considered the risk of lost expense if the utilities are never used. It was felt that, because in coordinated schemes the utility installation is phased into the building program, losses of this type were reduced.

*Applicability to the United States.* It is not clear at the present time the extent to which developers would be willing to accept financial responsibility for utilities in the United States. As was mentioned earlier, developers appear to play varying roles, but it can be anticipated that some developers would be willing to accept this responsibility if they could see a benefit from it. We are currently investigating this matter in more detail.

In California, utilities agreeing to common trenching have worked out procedures for one utility to do the trenching and bill the other companies or the developer for their share of the trench cost.

Various formulas have been proposed for common trenching in the United States. They vary from simple ones like splitting the cost to formulas as elaborate or perhaps more elaborate than those recommended.

In terms of the items discussed on which no recommendations were made, the last two appear to offer more concern to utilities in the U.S. than they appear to do in England. Rate of return on investment and installing facilities which may not be used are quite common arguments cited in the Regulatory Agency Hearing on Compulsory Undergrounding.<sup>10</sup>

**Recommendation 1.14:**

“Very careful attention should be paid to the question of responsibility for the trench in joint trenching schemes where there is divided responsibility for reinstatement.”

*Discussion.* If there is divided responsibility for reinstatement (backfilling) of the trench, the Study Group feels that the question of responsibility in the case of damage by one utility to another must be carefully studied before any common trenching is performed. They feel that the problem vanishes when a multiskilled crew is used in the installation.

*Applicability to the United States.* The same problem would also exist in the United States. Some utilities have liability statements in their agreements or contracts that define the responsibilities.<sup>11</sup>

In addition to the recommendations detailed above there were six others which covered such items as notes on planning applications drawing attention to the need for early consultation, suggested changes in English laws concerning easements and rights-of-way, and changes in the housing laws. These changes were suggested in order to encourage the use of common trenching by increased contact between developers and utilities at an early date and to allow the utilities to install below the footpaths. Changes in the housing laws to allow local housing authorities to act as agents for public utilities on building sites are also suggested.

**1.2.6 A Case Study in Common Trenching<sup>12</sup>**

The Harlow Green (phase II) is a local Authority development project containing 273 low-rise, four- and five-person units in the County Borough of Gateshead, England. Because their housing designs were being used, the National Building Agency (NBA) became involved in the project. Seven months after the start of the project it became evident that housing was being built faster than external works construction. At this point NBA suggested that coordinated services in a common trench be tried. The client and general contractor both agreed, and the NBA was selected to act as coordinator. Services involved were high- and medium-voltage electricity, gas, water, telephone, and cable TV.

As finally carried out the project has 940 yd of trench having two services, 1650 yd of trench containing three utilities, 360 yd of trench containing four utilities, and 160 yd of trench containing five services. No trench contained all six utilities.

A meeting was held with all utilities, and a typical cross section for the proposed trench was agreed to.

The utilities agreed to participate if the price was acceptable. Following this a common utility layout was prepared for the general contractor, and costs for each type of trench were determined and apportioned between the utilities. However, during the price negotiations between the utilities and the contractor, installation proceeded in the normal fashion; as a result the potential area for using common trenching was reduced.

A plan was drawn up showing the phasing of the trenching operation and detailed drawings of each section of trench and the utility locations in the trench. Working arrangements for each trench section, size of crew, etc., were developed and a work schedule prepared. Also, a sequence of operations was developed which was essentially the same as that proposed by the Technical Study Group.

Upon completion of the program a questionnaire was sent to the utilities involved to get their opinions on the methods used vs their previous practices, especially in terms of costs and communications. The telephone and TV experienced no reduction in costs due to coordination. The deeper services such as electric, gas, and water derived the most benefit. It was estimated that savings were about 5 to 10%, with even greater savings anticipated in future schemes.

Coordination and communication between the utilities and the general contractor improved considerably in the areas of the project where common trenching was performed. Using the scheduling program it was possible for the utilities to use its manpower more efficiently, and it was anticipated that future projects could be done with fewer men.

Running services directly to the building wall or foundation proved very successful, as it allowed final connections to be made at any time without interference to the general contractor.

The results of this operation indicated that the contractor derives the greatest benefit from common trenching, followed by the deeper utilities such as water, gas, and electricity. The main advantage to the contractor was the faster rate at which the dwellings could be occupied and the quicker return of rents on the capital invested by the developer. However, because of the limited use of common trenching in the project, it was not possible to determine these savings.

It was recommended that in the future the coordinators work should commence at the design stage. When an external body is retained as coordinator a fee should be involved. It was also suggested that a fair apportionment of this fee would be: the general contractor – 40%; the client, water board, gas board, and electricity board –

15% each. Telephone and cable TV would not contribute, probably because they realize no apparent cost savings.

### 1.2.7 Conclusions

The English study and related experiments are probably the most comprehensive attempt made to look at the problems involved in utility installation and the role that common trenching would make in improving utility installation practices. It also points out that advantages will occur through greater cooperation and coordination between the developer and the utilities even if common trenching is not employed. However, as previously noted, some of the procedures suggested might not be applicable in the United States at this time. Also, the problems are somewhat different in private developments, especially where the locations of the housing are not fixed. Even in this case greater coordination between the developer and the utilities would ensure that the main part of the distribution system could be provided in phase with the building program, so that utilities would be available when the housing is ready for occupancy.

### 1.2.8 Recommendations

Based on the results of our analysis of the English study and independent evaluation of the "state of the art" of common trenching practices in the United States, it is recommended that the following items be included in implementing the potential application of common trenching or coordinated installation in the United States.

1. An equivalent "working group" composed of developers, contractors, and utility engineers should be convened to develop recommended procedures for use in the United States. This group could be formed by HUD or some other group such as the National Academy of Engineering or the American Public Works Association.

2. A detailed program of experiments should be prepared to evaluate the procedures outlined by this group in order to determine if further changes in procedures should be made. One other function of these experiments would be to allow the determination of time and cost savings to the developer and the utilities.

3. When procedures have been developed which are acceptable to developers and the utilities, an attempt should be made to make them common practice in all new developments. This could be done by developing model ordinances, codes, or rules which could be disseminated by HUD or perhaps adopted by the State Utility Regulatory Agencies.

### REFERENCES

1. *Co-ordination of Underground Services on Building Sites: Part 1, The Common Trench*, R and D Bulletin, Ministry of Public Building and Works, Report SfB Ab8-UDC 696,69.027.7 (1968).
2. *Co-ordination of Underground Services on Building Sites: Part 2, Co-ordination Management*, R and D Bulletin, Ministry of Public Building and Works, Report SfB (A1FX)-UDC 69.00:658 (1969).
3. E. S. Gardner, Jr., "Joint Utility Planning and Use of a Common Trench Can Work," *Trans. Distribution* 22(12), 60-62 (December 1970).
4. J. C. Smith and L. A. Kemnitz, "Power and Telephone in Common Trench Cut Underground Cost," *Elec. World* 157(1), 48-51 (January 15, 1962).
5. T. Simkins, "Common Trench-Uncommon Difficulty," *Underground Eng.* 2(3), 29-33, 55 (April/May 1971).
6. J. A. Fairchild, "Developing a Joint-Trench Program," preprint Pacific Coast Gas Association Distribution Conference, Tucson, Arizona (April 8, 1968).
7. K. S. Oliphant, "Coordination Cuts Costs of Undergrounding," *Elec. Construct. Maint.* 65(3), 116-20 (March 1966).
8. M. F. Tutland, "Single-Crew Installation of Joint URD Cuts Costs," *Trans. Distribution* 19(6), 32-35 (June 1967).
9. J. J. Kassner, "Relocating Substreet Utility Lines," *Civil Eng.* 38(4), 86-88 (April 1968).
10. Hearings by the State of New York Public Service Commission Pertaining to Underground Electrical and Telephone Facilities - Phase I Cases 25352 and 25396 (1970).
11. SMUD Procedure for Executing Joint Underground Ventures with Other Utilities, California Municipal Utility District, Sacramento (July 15, 1968).
12. "The Co-ordination of Underground Services - A Case Study," The National Building Agency, Report SfB (5)-UDC 696-SBN 901502 17 0 (July 1970).

## B. Urban Growth Patterns

### 2. An Analysis of Population Concentration and Dispersal in the United States, 1940-1970

Robert A. Bohm\*     David A. Patterson†

#### 2.1 INTRODUCTION

Recent work on urban decentralization has highlighted the relationship between urbanization and population concentration.<sup>1,2</sup> From this work, two distinct concepts of urban decentralization have emerged. The first of these equates urban decentralization with the decline of central cities and central business districts and the growth of the suburbs, that is, with what more commonly is referred to as urban sprawl.<sup>3</sup> The second concept of urban decentralization revolves around a conscious policy to relieve population pressure on major metropolitan areas. Among the many alternatives proposed in this latter context, a few of the more prominent are as follows: (1) subsidizing second-order metropolitan areas or medium-size cities,<sup>1</sup> (2) developing growth poles,<sup>4</sup> and (3) encouraging migration to rural areas.<sup>5</sup>

Analytically, urban decentralization is a process which results from changes in the spatial distribution of population. This report provides basic information on intrastate population concentration. Clearly, information such as this is a necessary input for any conscious policy of urban decentralization.

#### 2.2 TECHNIQUE OF ANALYSIS

The Gini coefficient-Lorenz curve‡ method is used here to describe population concentration within states.<sup>§</sup> States, of course, are far from ideal regions, especially from the economic point of view. However, they have the great virtue of constant total area over time. By virtue of data availability, the intrastate unit of observation chosen for this analysis is the county.¶

To construct Lorenz curves and calculate Gini coefficients an ordered array of each states' counties is formed on the basis of gross county population density. The array is then plotted to yield a Lorenz curve.

Specifically, the coordinates of the first point on the Lorenz curve are the percent of state area and state population in the county with the lowest gross population density. The second point on the Lorenz curve is the cumulative percent of state area and state population of the two counties with the lowest gross population densities.

By way of illustration, Lorenz curves for the United States in 1940, 1950, 1960, and 1970 are depicted in Fig. 2.1. In this case, the array of counties includes all counties in the United States and ignores state boundaries. As can be seen in Fig. 2.1, cumulative population has been plotted on the vertical axis and cumulative area on the horizontal axis. The four Lorenz curves lie

---

\*Department of Finance, University of Tennessee, Knoxville.

†Tennessee Valley Authority, Knoxville, Tennessee.

‡Lorenz curves, as illustrated in Figs. 2.1-2.5, are visual displays of the concentration of an attribute with respect to a given item such as people or land area. In this case they show the differential concentration of population by county, although they are most frequently used to show the inequality of income distribution. If the distribution were equal - all land areas having an equal share of population - the curve would be the 45° line visually shown. The departure from equality can be seen visually in the Lorenz curve, or a Gini coefficient can be computed as its numerical index. The Gini coefficient is the ratio of the area between the curve and the 45° line to the area of the lower triangle, multiplied by 10<sup>3</sup>.

§Gini coefficients and Lorenz curves are often employed in income distribution studies. For a discussion of some of the drawbacks and difficulties encountered in Gini coefficient-Lorenz curve analysis, see R. A. Bohm and David A. Patterson, *Intra-State Population Concentration 1940-1970*, ORNL-HUD-26 (in press).

¶In some states, it has been necessary to combine small numbers of counties to obtain comparable data over time. This problem was especially acute in Virginia due to the existence of independent cities.

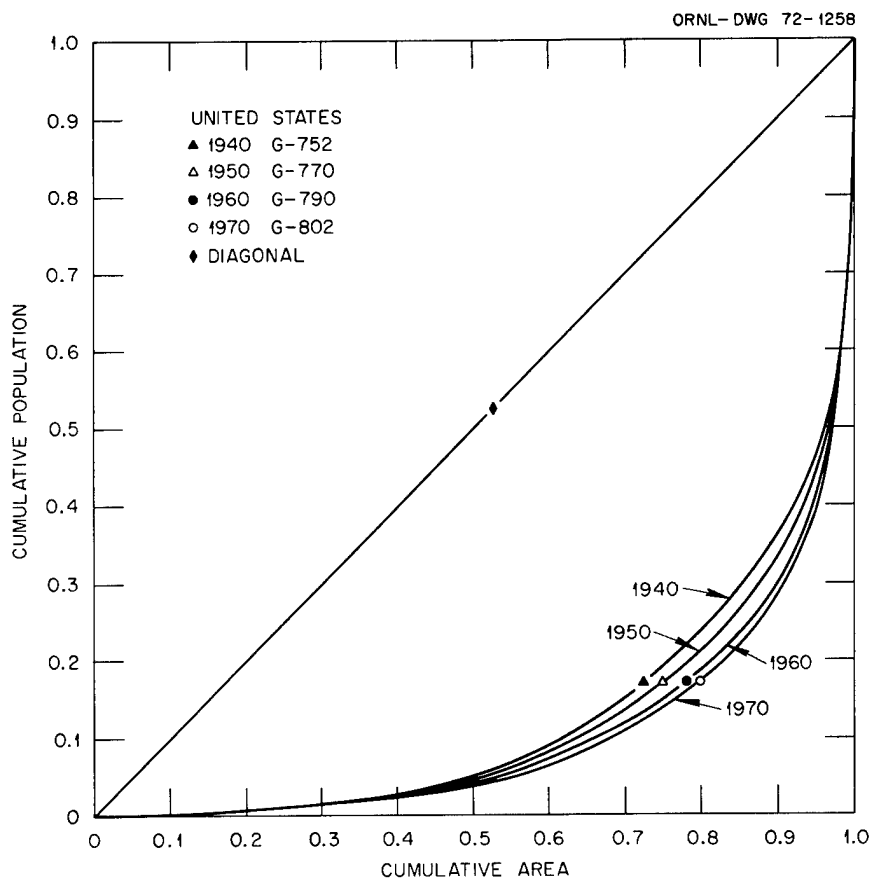

Fig. 2.1. Population concentration, United States, 1940-1970.

below the diagonal and indicate increasing concentration of the population between 1940 and 1970.

Gini coefficients are computed from each of the Lorenz curves in Fig. 2.1. The Gini coefficient is defined as the area between the diagonal and Lorenz curve divided by the area of the entire triangle below the diagonal. The coefficient may vary from 0 to 1. The closer the Gini coefficient is to unity the greater the spatial concentration of the population. In order to simplify the exposition to follow, all Gini coefficients have been multiplied by 1000. For the United States, the 1940, 1950, 1960, and 1970 Gini coefficients are 752, 770, 790, and 802, respectively.

### 2.3 FOUR CLASSES OF INTRASTATE POPULATION CONCENTRATION BEHAVIOR

Inspection of each states' Lorenz curves and Gini coefficients has led to the identification of four distinct patterns of changing population concentration between 1940 and 1970. These four patterns are: (1) states

continuously centralizing, 1940-70; (2) states centralizing at a markedly decreasing rate, 1940-70; (3) states showing no change, 1940-70; and (4) states continuously decentralizing.

Eighteen states have been classified as continuously centralizing (group A).<sup>\*</sup> These states are listed together with their respective Gini coefficients in Table 2.1.<sup>†</sup> Iowa is typical of these states with Gini coefficients of 308 in 1940, 352 in 1950, 400 in 1960, and 442 in 1970, a relatively constant change in each ten-year period. This continual centralization in Iowa is clearly illustrated in Fig. 2.2. For the entire 30-year period, the Iowa Gini increases 43.5%. This total change is divided rather evenly between the three decades. The 1940-1950 change is 14.3%. The 1950-1960 and

<sup>\*</sup>Several small states and states with few counties have been combined for the purposes of this analysis.

<sup>†</sup>New Hampshire-Vermont, No. 19 of this group, has been temporarily deleted from the analysis. Lorenz curves and Gini coefficients for Alaska and Hawaii have not been computed.

**Table 2.1. States continuously centralizing 1940–1970 (group A)**

States	Gini coefficients			
	1940	1950	1960	1970
Colorado	650	706	774	806
Georgia	436	508	580	624
Idaho	619	645	667	684
Iowa	308	352	400	442
Kansas	527	568	637	670
Maine	512	532	544	565
Minnesota	532	572	621	665
Mississippi	259	302	358	388
Montana	463	505	542	580
Nebraska	588	623	669	710
Nevada	527	640	734	838
North Carolina	356	383	427	465
North Dakota	292	326	383	452
South Carolina	299	336	375	404
South Dakota	487	506	531	553
Texas	634	688	742	777
Utah	769	802	834	854
Virginia	444	530	580	631

**Table 2.2. States centralizing at a markedly decreasing rate 1940–1970 (group B)**

States	Gini coefficients			
	1940	1950	1960	1970
Alabama	361	433	495	514
Arizona–New Mexico	473	567	646	676
Arkansas	307	367	424	438
Florida	554	607	651	657
Illinois	674	701	731	745
Indiana	471	505	540	551
Kentucky	380	435	487	515
Louisiana	482	536	577	584
Michigan	707	734	752	754
Missouri	579	632	678	697
Ohio	586	610	626	633
Oklahoma	437	506	588	621
Tennessee	427	490	548	565
Washington	635	664	686	699
West Virginia	435	483	503	510
Wisconsin	553	591	640	658
Wyoming	354	388	434	419

1960–1970 changes are 13.6 and 10.5%, respectively.

Returning to Table 2.1, the average percentage change in the Gini for all states in group A is 30.5 for the entire period. For the three decades individually, the average percentage changes are 9.9, 10.2, and 7.3. The state with the largest 30-year rate of concentration is Nevada. The smallest 1940–1970 percentage change is recorded in Maine.

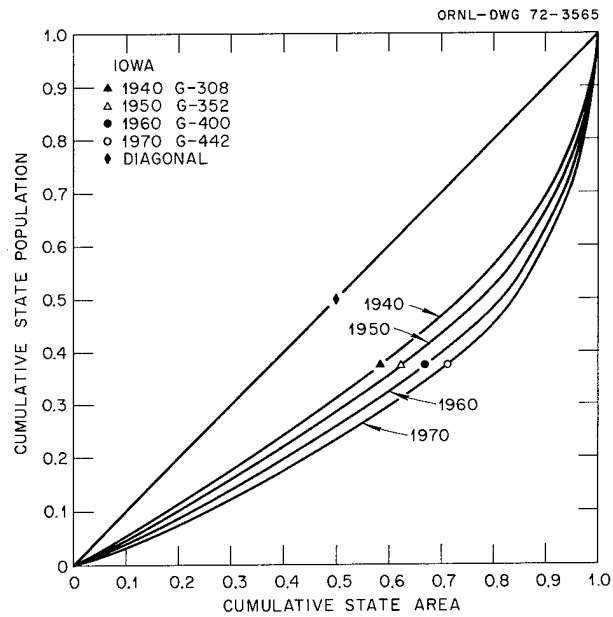

**Fig. 2.2. Population concentration, Iowa, 1940–1970.**

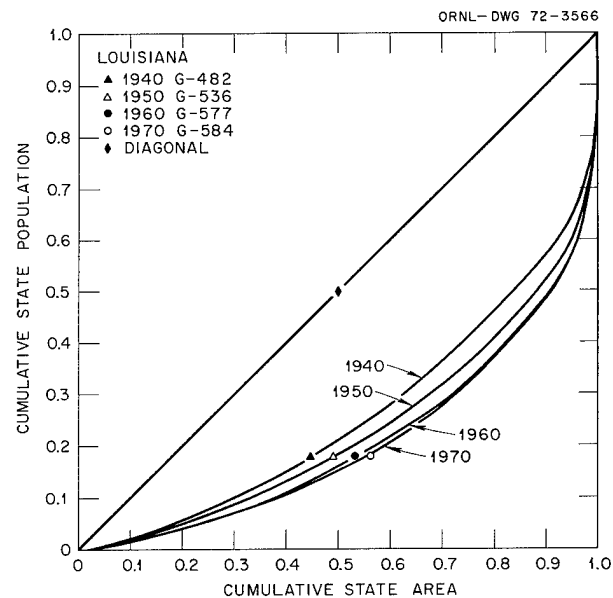

**Fig. 2.3. Population concentration, Louisiana, 1940–1970.**

Seventeen states exhibit a marked decline in their rate of population concentration between 1940–1970 (group B). Louisiana is typical of this group. Gini coefficients for this group and Lorenz curves for Louisiana form Table 2.2 and Fig. 2.3, respectively.

Compared with group A states, the average decade-to-decade percentage change in the Gini for group B states falls rapidly. The 1940–1950 figure is 12.2%,

while the 1950–1960 and 1960–1970 figures are 8.8 and 2.2% (recall the comparable group A figures were 9.9, 10.2, and 7.3%). The average 30-year change for group B was 25.4%.

The Lorenz curves for Louisiana clearly illustrate a marked decline in centralization between 1960 and 1970. The 1960 and 1970 curves lie almost on top of each other. The Gini coefficients for Louisiana and their percent changes are also indicative. The Gini coefficients are 482, 536, 577, and 584 for 1940, 1950, 1960, and 1970, respectively. The percentage changes are 11.2, 7.6, and 1.2 for the periods 1940–1950, 1950–1960, and 1960–1970, with a 1940–1970 change of 21.2%.

California, Maryland–Delaware, New York, Oregon, and Pennsylvania exhibited no extensive degree of centralization between 1940 and 1970. In fact, New York experienced decentralization between 1950–1960 and 1960–1970. Gini coefficients for these five states form Table 2.3 (group C). The Lorenz curves for Pennsylvania may be found in Fig. 2.4.

The Gini coefficients for Pennsylvania confirm the visual impression created by Fig. 2.4. The coefficients are 644 for 1940, 649 for 1950, 655 for 1960, and 656 for 1970. The percentage changes per decade are 0.8, 0.1, and 0.002 (1940–1950, 1950–1960, and 1960–1970, respectively). The percentage change for the period 1940–1970 is only 1.9. The comparable average figures for the five states are 1.1, 0.8, 0.6, and 2.6% for the total period.

Table 2.3. States showing no change (group C)

States	Gini coefficients			
	1940	1950	1960	1970
California	788	791	796	797
Maryland–Delaware	620	637	648	651
New York	819	821	820	818
Oregon	725	734	740	762
Pennsylvania	644	649	655	656

Table 2.4. States continuously decentralizing (group D)

States	Gini coefficients			
	1940	1950	1960	1970
Connecticut– Massachusetts– Rhode Island	523	510	488	470
New Jersey	702	683	645	607

Four states continuously decentralized during the 1940–1970 period. Three of these, however, had to be combined due to a small number of counties in each state. This leaves only two observations in this group (D), namely, Connecticut–Massachusetts–Rhode Island and New Jersey. Gini coefficients for these two areas may be found in Table 2.4. The decentralization process is illustrated by the Lorenz curves of New Jersey in Fig. 2.5.

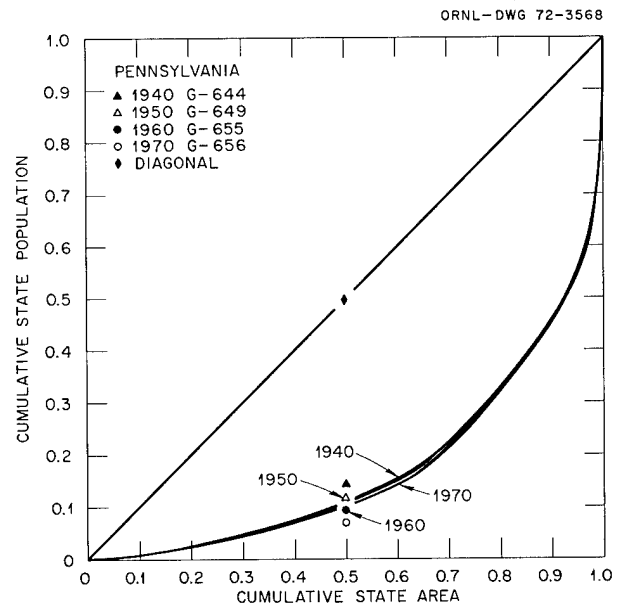

Fig. 2.4. Population concentration, Pennsylvania, 1940–1970.

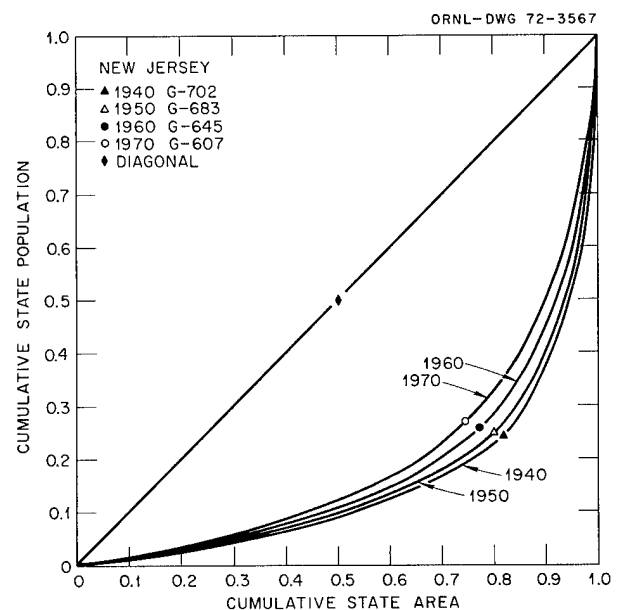

Fig. 2.5. Population concentration, New Jersey, 1940–1970.

As can be seen in Table 2.4, the Gini coefficients of both New Jersey and Connecticut–Massachusetts–Rhode Island fall continuously from 1940 to 1970. In Fig. 2.5, New Jersey's 1970 Lorenz curve lies closest to the diagonal. The percentage change in the New Jersey Gini from 1940–1970 was –13.5. The individual decade rates appear to indicate a slight acceleration in the rate of decentralization. The 1940–1950 rate was –2.7%, while the 1950–1960 and 1960–1970 rates were –5.6 and –5.7%, respectively.

#### 2.4 A PRELIMINARY ANALYSIS OF POPULATION CONCENTRATION AND DISPERSAL

The data presented in Sect. 2.3 create a strong impression that some process of population concentration and dispersal is taking place. It is quite tempting to hypothesize not only a time path for such a process – for example, concentration, no change, decentralization – but also a correlation between the time path of concentration/dispersal and the time path of intrastate urbanization. Clearly, group A states are mostly rural, while groups C and D states are mostly urban.

While such a simple generalization is, of course, illuminating and, in fact, may be true, it would seem important to point out at this time that the centralization-decentralization phenomenon summarized by the Lorenz curves and Gini coefficients presented above is somewhat more complicated than it may first appear. For example, increasing population concentration may involve: (1) a general intrastate rural-to-urban movement, (2) interurban movements favoring large over small cities, and (3) differentially higher rates of interstate migration to in-state urban areas than to rural areas. Decentralization might involve the reverse of 1 through 3 plus suburbanization around major cities. Finally, differential rates of natural increase may exist between large, medium, and small urban areas and rural areas.\* It is certainly entirely possible that the determinants of each of these components of total centralization-decentralization are quite different.

Before settling on any single explanation of population concentration/dispersal, therefore, a fairly broad range of hypotheses should be examined. This section represents a brief preliminary attempt at such an inquiry. Concentrating on the period 1950–1960,

\*For example, apparent decentralization may result from second-order metropolitan areas having higher rates of immigration and natural increase than the largest metropolitan areas in a state.

regression analysis is used to explain variation in the Gini coefficients. Specifically, the change in the Gini 1960/1950 is regressed against 1950 census data for each state or state group in an attempt to explain change primarily in terms of initial conditions. The following equation resulted from this analysis:

$$\begin{aligned} \text{GINI } 60/50 = & 1.00 - 0.0001 \text{ GDNSTY} \\ & (2.07) \\ & + 0.003\% \text{ AGMNG} + 0.116 \text{ MIGRT} + 0.001\% \text{ NW} \quad (1) \\ & (4.15) \quad (2.19) \quad (2.87) \end{aligned}$$

$$\begin{aligned} R^2 &= 0.67 \\ SE &= 0.037 \\ df &= 37 \end{aligned}$$

GINI 60/50 = change in Gini coefficient 1960/1950,

GDNSTY = gross state population density, 1950,

% AGMNG = percent of state employment in agriculture and mining, 1950,

MIGRT = state rate of net population migration, 1950–1960,

% NW = percent of state population nonwhite, 1950.

All the variables in Eq. (1) have what might be considered the expected sign. More specifically, higher initial densities result in marginally slower rates of concentration, while substantial numbers still employed in agriculture and mining provide fuel for more rapid centralization. Migration, which must be held constant if the intrastate variables are to be meaningful, appears to be urban oriented. All of the variables included in Eq. (1) are statistically significant at the 0.05 level or better. The figures in parentheses below the coefficients are "t" values. The  $R^2$  for the estimate is not spectacular (0.67) but may be considered fair to good for a cross-section regression.

#### 2.5 CONCLUDING COMMENTS

The ultimate aim of positive research, beyond the scientific aim of understanding, is to influence and improve policy decisions. In this regard, an understanding of conditions that influence the ebb and flow of population concentration is essential for those who would formulate an effective urban decentralization policy for the nation.

It is apparent from the preceding analysis that some form of centralization-decentralization process is taking

place within bounded regions (states) in the United States. It is further apparent that this process can be decomposed and systematically studied. Future research will be directed toward the development of linkages between the concentration-decentralization process and explicit policy variables. In this regard, analysis of the influence of changing transportation networks (e.g., interstate highways) has already begun. Additional time periods are now being studied, and an alternative measure of changing concentration (i.e., the change during a time period divided by the maximum change possible during that period) is being examined.

### 2.6 SUMMARY

In this study Lorenz curves are constructed and Gini coefficients are computed for each state in the contiguous United States for 1940, 1950, 1960, and 1970. These curves and coefficients indicate that changes in the spatial distribution of the population are quite different among the various states. For the 30-year period, each state fell into one of four distinct groups: (A) states continuously centralizing, (B) states centralizing at a markedly decreasing rate, (C) states exhibiting no change in population concentration, and (D) states continuously decentralizing. A preliminary regression

analysis for the 1950–1960 period indicates that the rate of population concentration is negatively related to population density and positively related to employment in agriculture and mining, net in-migration, and the percent of population nonwhite.

### REFERENCES

1. Charles L. Leven, "Trends in Metropolitan Growth and City Form," in *Education for Architectural Technology*, Washington University, St. Louis, Missouri, April 1966.
2. John R. Moore, *Centripetal and Centrifugal Forces in the American Economy*, ORNL-HUD-8 (November 1971).
3. John R. Meyer, John Kain, and Martin Wohl, *The Urban Transportation Problem*, Harvard University Press, Cambridge, Massachusetts, 1964.
4. J. R. Boudeville, *Problems of Regional Economic Planning*, University Press, Edinburgh, 1966.
5. *National Seminar on Human Habitation*, University of Tennessee Space Institute, Tullahoma, Tennessee, May 1969.

### 3. Interstate Highway Location and County Population Growth

Robert A. Bohm\*

David A. Patterson†

#### 3.1 INTRODUCTION

This report summarizes earlier findings on the regional impact of interstate highway location on county population growth during the period 1960–1970.<sup>1</sup> Additional results are presented indicating the effects of interstate highways on county population growth for 1960–1970 in counties with urban populations of less than 150,000 in 1960.

In this analysis, the process of county population growth is assumed to be largely autoregressive in nature.<sup>‡</sup> If this is the case, then population growth during the current period can be described as a linear function of past population change, that is,

$$\text{POP76} = \alpha + \beta_1 \text{POP65} + \beta_2 \text{POP54} + \epsilon, \quad (1)$$

where

POP76 = county population growth, 1970/1960,

POP65 = county population growth, 1960/1950,

POP54 = county population growth, 1950/1940,

$\epsilon$  = a random disturbance term.

Equation (1) describes a population growth path through time.

Other variables may be introduced into Eq. (1) to determine if they have any effect on population growth independent of past population growth. In this study, a group of variables designed to isolate the effects of interstate highways on county population growth are employed for this purpose. If the matrix *I* represents the group of interstate variables and the matrix *U* represents a group of unspecified control variables, then Eq. (1) may be rewritten as

$$\text{POP76} = \alpha + \beta_1 \text{POP65} + \beta_2 \text{POP54} + c[\mathbf{I}] + d[\mathbf{U}] + \epsilon, \quad (1a)$$

where *c* and *d* are coefficient vectors. The matrix *I* is composed of four dichotomous dummy variables. These variables are:

IS = 1 for all counties in which an interstate highway was completed by 1968; 0 otherwise.

ISI = 1 for all counties containing an intersection of two or more interstate highways by 1968; 0 otherwise.

ISA = 1 for all counties adjacent to IS counties; 0 otherwise.

ISIA = 1 for all counties adjacent to ISI counties; 0 otherwise.

Since the relationship described by Eq. (1a) is linear and there are a large number of variables involved, it is convenient to analyze the effects of the four interstate dummy variables on population growth (POP76) at the ordinate. This may be accomplished by evaluating Eq. (1a) at the point where POP65 = 0, POP54 = 0, and [U] = 0. At this point if [I] = 0 also, then

$$\text{POP76} = \alpha. \quad (2)$$

However, if one of the columns in [I], for example IS, is not equal to zero, then using  $c_1$  to indicate the coefficient of IS, we have

$$\text{POP76}^* = \alpha + c_1. \quad (2a)$$

Equation (2) indicates the value of POP76 for all counties in the sample when Eq. (1a) is evaluated at the ordinate. In Eq. (2a), POP76\* gives the ordinate value of POP76 for those counties in which IS = 1. Dividing (2a) by (2) and rearranging terms yields

$$\frac{\text{POP76}^*}{\text{POP76}} = 1 + \frac{c_1}{\alpha}. \quad (3)$$

\*Department of Finance, University of Tennessee, Knoxville.

†Tennessee Valley Authority, Knoxville, Tennessee.

‡For a more elaborate discussion see ref. 1.

The ratio  $c_1/\alpha$  is the percentage difference between the rate of population growth for all counties (including IS counties) and IS counties. The effect on population growth 1960–1970 of all variables in the matrix [I] may be evaluated in this manner. Furthermore, the ratio  $c_1/\alpha$  is constant for all values of the linear function expressed by Eq. (1a).

### 3.2 REGIONAL EFFECTS

Equation (1a) has been estimated by means of ordinary least squares for each census division. In this section, the influence of the interstate variables on county population change 1960–1970 is discussed. The results of dividing each statistically significant coefficient of the four interstate variables by the regression constant are recorded in Table 3.1, that is, the entries in Table 3.1 are ratios such as  $c_1/\alpha$  described by Eq. (3). For example, in the South Atlantic division, the constant term  $\alpha$  equals 0.534, while the coefficient of IS,  $c_1$ , equals 0.0341.\* The ratio  $c_1/\alpha = 6.4$  is the value recorded in the South Atlantic-IS cell in Table 3.1. The figure 6.4 is the differentially faster rate of growth of IS counties in the South Atlantic region (i.e., interstate counties grew 6.4% faster than all counties in the South Atlantic division during the period 1960–1970).

The results recorded in Table 3.1 indicate some interstate influence on county population growth in every census division except the East North Central division. However, the quantitative significance of

interstate related changes is quite different in different regions. For example, the ratio of the coefficient of ISIA divided by  $\alpha$  is 13.7% in the East South Central division and 28.8% in the West South Central division. The variables IS and ISIA are the most pervasive. Each has an effect in four divisions.

### 3.3 EFFECTS OF INTERSTATE HIGHWAYS IN COUNTIES WITH URBAN POPULATIONS LESS THAN 150,000 IN 1960

In this section counties are classified into ten groups on the basis of their respective urban populations up to 150,000. For example, the first group includes all counties with urban populations ranging from 0 to 2500. Group 10 includes counties with an urban population in the range 100,000 to 150,000. Counties with urban populations in excess of 150,000 are not analyzed at this time.

Equation (1a) was estimated for each group. The statistically significant coefficients of the interstate variables have been divided by the regression constant and recorded in Table 3.2. Observation of Table 3.2 reveals that the variable IS has a mild effect on population growth in the counties with relatively small urban populations. In counties with larger urban populations, the variables ISI and ISIA are quite strong. Perhaps the most interesting results recorded in Table 3.2 are those for the 0 to 2500 urban population category. Interstate (IS) counties with urban populations between 0 to 2500 in 1960 grew at a rate 41.6% greater than all counties in this group between 1960 and 1970.

\*See ref. 1 for complete regression results.

Table 3.1. Significant coefficients of interstate variables divided by the regression constant  $\alpha$  by region

Source: ref. 1.

Census division	Regression constant ( $\alpha$ )	Variable name					Sample size <sup>b</sup>
		IS	ISA	IS + ISA <sup>a</sup>	ISI	ISIA	
New England	0.224			34.4			67
Middle Atlantic	0.456				10.5		146
East North Central	0.390						436
South Atlantic	0.534	6.4				22.8	551
East South Central	0.518					13.7	394
West South Central	0.824	5.1	4.9		25.6	28.8	470
West North Central	0.522	4.4			13.0	15.3	618
Mountain	5.668	50.9					278
Pacific	1.942		121.9				0.33

<sup>a</sup>Several regressions were run with the IS and ISA variables and the ISI and ISIA variables combined.

<sup>b</sup>Number of counties.

Table 3.2. Significant coefficients of interstate variables divided by the regression constant  $\alpha$  for counties with urban populations less than 150,000 in 1960

Urban population in county	Regression constant ( $\alpha$ )	Variable name					Sample size <sup>b</sup>
		IS	ISA	ISI	ISIA	ISI + ISIA <sup>a</sup>	
0-2,500	4.229	41.6					973
2,501-5,000	0.656	10.7					527
5,001-10,000	0.613	7.0	5.4			10.4	485
10,001-20,000	0.710	6.5					399
20,001-30,000	0.626	6.1			11.2		172
30,001-40,000	0.572			27.8	26.4		110
40,001-50,000	0.793						59
50,001-75,000	0.774			21.1	18.4		78
75,001-100,000	0.752						42
100,001-150,000	0.476			20.8	28.5		65

<sup>a</sup>Several regressions were run with the IS and ISA variables and the ISI and ISIA variables combined.

<sup>b</sup>Number of counties.

### 3.4 SUMMARY

Interstate highways have exerted considerable influence on county population changes during the decade 1960-1970. Regionally, these effects appear to have been strongest in areas where past investment in highways has lagged, that is, the South Atlantic, East South Central, West South Central, West North Central, and Mountain divisions. Interstate effects are also widespread in counties with extremely different urban characteristics. Interstate intersections apparently exert a powerful stimulus in counties with urban populations

in the range 30,000 to 150,000. In counties with urban population less than 30,000 the effect of interstates on county population growth ranges from 6.1 to 41.6%.

### REFERENCES

1. R. A. Bohm and D. A. Patterson, "Interstate Highways and the Growth and Distribution of Population," *Proceedings of the American Statistical Association*, Social Statistics Section, 1971.

## 4. How Cities Grow

Everett S. Lee

For many years loud voices — from Thomas Jefferson to Lewis Mumford — have clamored for a cessation of growth in the great cities. In a sense, their wishes have been realized, at least for the central cities of metropolitan areas. Whereas urbanized areas (those continuously built-up districts that center around cores of 50,000 or more inhabitants) have grown to include three out of every five Americans, the central cities themselves have lagged behind. Indeed, within the limits of their 1960 boundaries, they have hardly grown at all.

Cities grow or decline in three ways, each of which has very different social and economic consequences. The first is by natural increase, the balance of births and deaths, and now turning toward natural decrease. The second is by net migration, the difference between in-migration and out-migration, currently out- for whites and in- for blacks. Finally, cities grow not only up but out as they expand their boundaries through annexation or consolidation. In the past, spectacular gains have been made in this fashion. When Brooklyn was absorbed by New York City it was the seventh largest city in the country, and Philadelphia incorporated some of the largest cities of the day when it set its boundaries to include those almost forgotten cities of Northern Liberties, Spring Garden, and Kensington.

### 4.1 NATURAL INCREASE AND MIGRATION

Cities have always lagged behind the rest of the country in natural increase, but never before in so dramatic a fashion. Birth rates are now so low that there are large areas in many cities in which the number of births is exceeded by the number of deaths. As might be expected, the populations of such resort or retirement towns as Atlantic City and St. Petersburg actually fell through natural decrease between 1960 and 1970. However, a similar situation now prevails in Pittsburgh, and in every one of the larger cities of the Northeast, except New York, rates of natural increase were below 5% and trending downward. In the Nation's Capital, natural increase between 1960 and 1970 was less than 1%, as it was for Wilmington, Delaware, also. In at least 20 of the great cities of the Northeast, we may expect

deaths to exceed births among whites by the middle of this decade. The same is true in such southern cities as Richmond, Virginia, and Wheeling, West Virginia, while in the West, San Francisco and Portland have similar patterns of growth.

Low rates of natural increase are related to changes in migration pattern and in population structure. Traditionally, cities have attracted large numbers of young adults who were in the ages of greatest reproductivity as well as productivity. Today, the number of young people entering the city is relatively small, and there is much migration from the central city to the suburbs. Typically, today's in-migrants are black, while the out-migrants are white. In fact, the only cities in the Northeast to gain whites through migration were Vineland, New Jersey; Brockton, Massachusetts; and Manchester, New Hampshire. In the North Central states, the list is somewhat longer. Prominent among these cities are university and governmental centers.

This illustrates an interesting relationship between migration and natural increase. The importance of educational institutions in attracting migrants is now quite clear, but to find that university towns have high rates of natural increase is unexpected. Nevertheless, among the North Central cities with the highest rates of natural increase over the past decade are Ann Arbor and Lansing, Michigan; Madison, Wisconsin; Champaign-Urbana, Illinois; and Columbia, Missouri.

No small part of the cities' problems is occasioned by the out-migration of whites, which for some cities has become a veritable exodus. Washington, D.C. lost 40% of its population through migration between 1960 and 1970, and St. Louis, Cleveland, and Detroit suffered losses of a third or more. For the 12 largest cities, the losses of white population through migration amounted to 2,500,000 persons, 13% of the 1960 population.

Taken together, heavy out-migration and low natural increase produced an absolute decline of more than 600,000 whites in central cities over the last decade. As indicated in Fig. 4.1, the loss was concentrated in the largest cities. In central cities of smaller metropolitan areas, there were gains of white population, proportion-

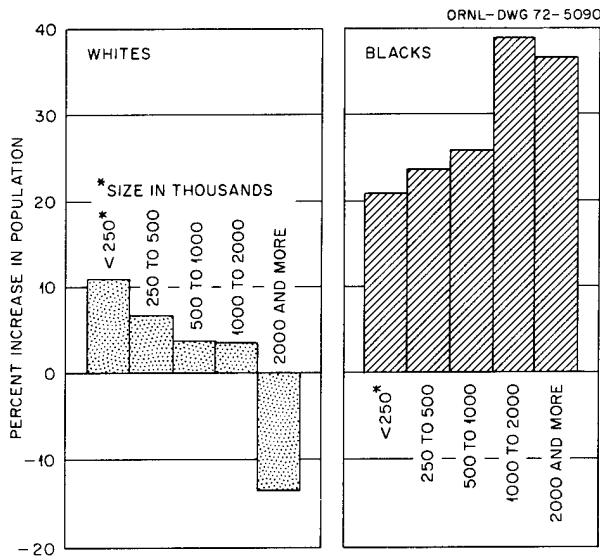

Fig. 4.1. Increase in population in central cities, by size of metropolitan area: 1960-1970.

ately greater as size decreased. In contrast are the sharp gains of blacks, over 20% for the central cities of metropolitan areas of less than 250,000 and rising with size of area to almost twice that amount.

One effect of these trends is the considerable variation in the proportion of blacks at different ages. As shown in Fig. 4.2, about 20% of central city populations are black as compared with 5% of the ring populations. But more than 25% of the children in central cities are black as against 12% of those aged 65 and over. If white births continue to decline and out-migration remains the rule, the trend toward higher proportions of blacks in the central cities will accelerate. An immediate effect will be a sharp increase in the number of central city blacks seeking to enter the labor force, a group for which we already have great difficulty in finding jobs. For that matter, the entire labor force in central cities will become increasingly black as larger and larger black cohorts pass through the working ages.

By contrast, the variation by age in the proportion black in the ring counties is not very great — little more than a percentage point from the youngest to the oldest ages. At first glance, this would seem to indicate that the black population in the rings is growing in much the same way as the white population and achieving a similar population structure. However, it may be that in the increasing suburban ghettos there are many black children, while in the upper income areas where blacks

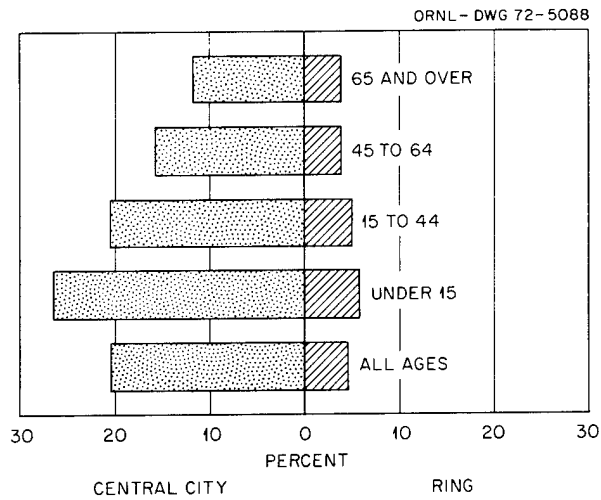

Fig. 4.2. Percent of black population: 1970.

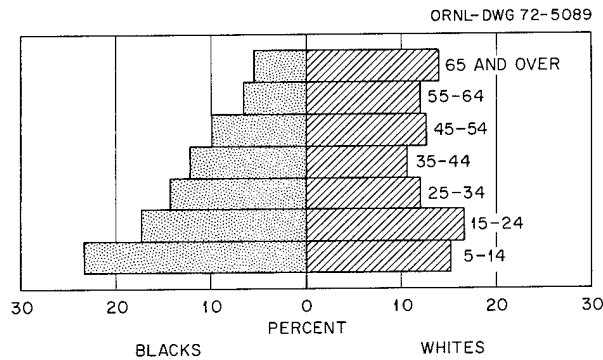

Fig. 4.3. White and black population in central cities—North-east: 1970.

have recently moved there are few children and relatively many middle-aged blacks. Thus, our apparently, “normal” black population in the rings may simply result from the aggregation of two very different population structures.

Differences in the age structures of white and black populations are highlighted in Fig. 4.3. The graph for blacks is characteristic of a rapidly growing population with many young people and few old people, and with each younger cohort larger than its predecessor. The graph for whites, however, represents a declining population, and one that is losing heavily through the out-migration of persons between the ages of 25 and 45. The smaller number of persons aged 5 to 14 than of those aged 15 to 24 reflects the falling production of children and the out-migration of families, while the relatively large number of the aged is indicative of the

increasing proportion that they form of white central city populations. Contrary to the situation found among blacks, we may expect each succeeding cohort of white workers to be smaller than its predecessor because out-migration will further reduce the size of the younger age groups.

#### 4.2 ANNEXATION

Without annexation, there would have been practically no growth in the population of central cities. Within their 1960 limits, the increase in the 243 central cities enumerated in 1970 amounted to little more than 50,000 persons, less than a tenth of one percent of the 1960 population. Of the increase of approximately 4,000,000 persons, 98% was accomplished by annexation. Thus, the central cities have been able to grow as much as they did by incorporating territory from the suburbs or, in some instances, by incorporating enclaves of territory that had long been surrounded by the central city.

The ability to annex depends very much upon the region in which the central cities are located and upon the size of the city. In Fig. 4.4, increases through annexation are contrasted with increases within the

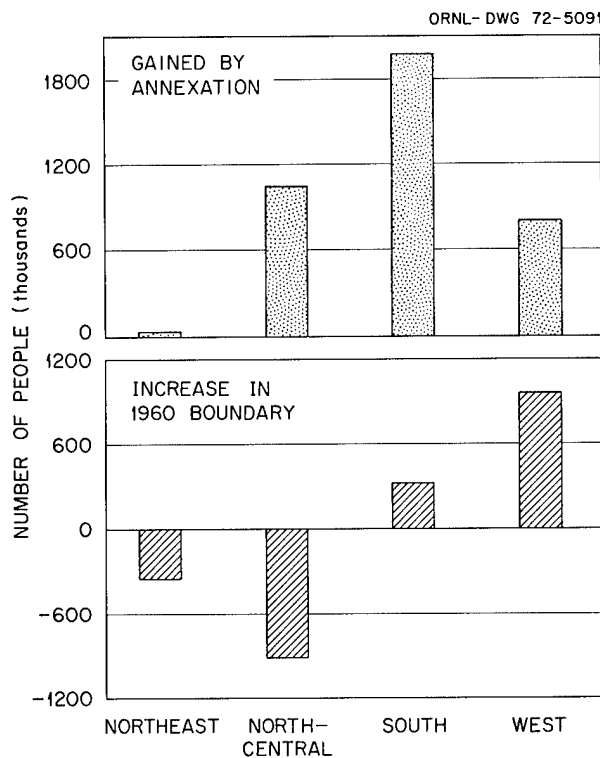

Fig. 4.4 Increase in population of central cities, by region: 1960-1970.

1960 territory by region. In the Northeast and in the North Central region, there were declines in populations within central cities, and in no region were the gains within original boundaries impressive. In the Northeast, the gain from annexation was negligible, only 30,000 for the entire region, while in the North Central region a gain of more than a million was sufficient to overcome a large decrease within 1960 boundaries. As a result, central cities in the North Central region had a net gain of about 150,000 persons, still less than 1% of the 1960 population. In the West, a gain of 800,000 persons through annexation accounted for almost half of the total growth, while in the South the annexation of almost 2,000,000 people accounted for five-sixths of the total growth.

The effect of annexation also varied by size of place as shown in Fig. 4.5. Cities in metropolitan areas of 3,000,000 or more barely held their own during the last decade, registering an increase of only 38,000, more than half of which was contributed by a single annexation.

For every size class, the increase in population within central cities in metropolitan areas of 100,000 or more was small. The increase was less than 1% within 1960 boundaries, and for the central cities in metropolitan areas of 500,000 to 1,000,000 population there was actually a decrease. Only in the central cities of metropolitan areas of 100,000 to 1,000,000 inhabitants

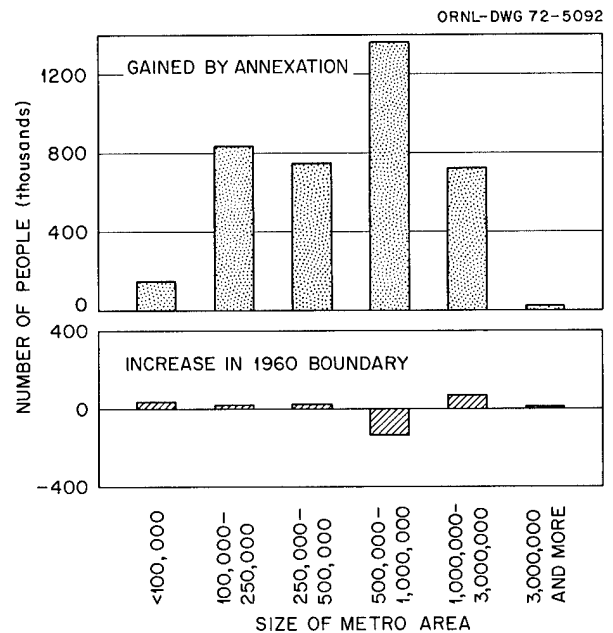

Fig. 4.5 Increase in population of central cities by size of metropolitan area: 1960-1970.

did annexation represent gains of as much as 10% of the 1960 populations.

One of the most interesting aspects of urban growth was the uniformity of growth for all classes of cities — approximately zero. With current patterns of migration and natural increase, this portends sharp decreases in population for cities of all sizes if annexation continues to be difficult.

Obviously, annexation is most difficult for the largest cities since they have already expanded to county or township boundaries. Thus, New York City includes five entire counties, and the City of Philadelphia is coterminous with the County of Philadelphia, and the same is true in Denver and Jacksonville. For small places, the township system which prevails in New England may be an advantage, since rural territory is often included with the central place, making expansion up to the town limit quite easy. But as cities grow larger a political organization which has counties as the major political subunit is advantageous. It is largely for this reason that annexation has played so small a role in the Northeast.

At this point we should note that annexation is a major element of growth down through cities or towns of quite small population. It is not uncommon for small towns, like central cities, to lose population at the core and recoup it by extending their boundaries into contiguous areas. In Dahlongega, Georgia, for example, a loss of 45% of the 1960 population within original boundaries was made up for by annexing territory which included a population a little larger than that which had been lost. In fact, in the entire state of Georgia, the majority of incorporated places of over 5000 population would have lost population if they had not been able to annex territory, and the great majority of Georgia towns and cities that registered gains within 1960 boundaries were places included within Standard Metropolitan Statistical Areas, or those which had a college or university, or were located near an armed forces establishment. In Fig. 4.6, the percentage of places which annexed population is shown by size for the Northeast and the South, beginning with places of 2500. It is evident that the proportion of incorporated places that annexes territory increases with size of place. At the smallest level, rather few places annexed territory, but in the next size class it was up to 40%, and for cities of 20,000 to 25,000 population it was on the order of two out of three cities.

In the Northeast, the situation was very different, and in no size class was the proportion annexing as much as one in seven. In the North Central region and in the

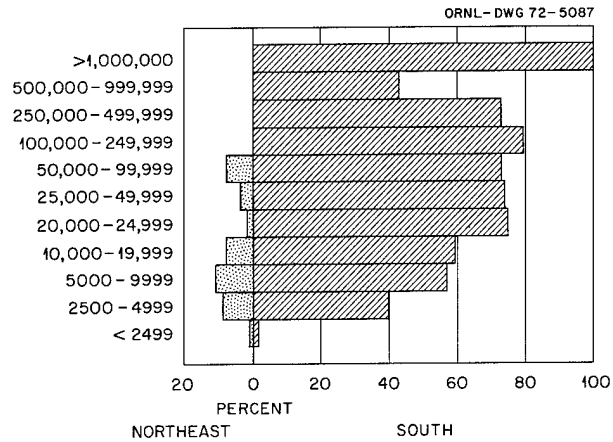

Fig. 4.6. Percent of places annexing population between 1960 and 1970 by size of place or metropolitan area.

West, the proportions annexing were not unlike those in the South.

The effect of political organization by townships is quite evident in New England. There was not a single annexation regardless of town or city size in Maine, Vermont, New Hampshire, Massachusetts, and Rhode Island, and only one in Connecticut. Even so, this annexation accounted for only three people, and leads one to speculate that the reason for annexation may have been similar to that for one annexation in Athens, Georgia. In that city a referendum permitted serving liquor by the drink inside the city limits, while brown-bagging remained the rule in the surrounding parts of the county. Taking advantage of a provision which permitted the annexation of uninhabited territory without a referendum, the city fathers incorporated the country club within the city limits.

There were other states where annexations were negligible, most notably the Middle Atlantic states of New Jersey, where there were only three annexations affecting fewer than 300 persons. In New York State, there were only two annexations in cities of 20,000 or more inhabitants, both of which involved a negligible number of persons. Similarly in Pennsylvania, annexations in cities of 20,000 or more inhabitants were only seven in number, together accounting for only about 3000 people.

The development of cities, therefore, is greatly hampered by local boundaries which were established many years ago and which now divide urbanized areas and metropolitan areas into bewildering complexes of towns and counties, each intent upon the preservation of its territorial integrity, regardless of the administrative chaos which it occasions and regardless of the

resulting lack of ability to plan for entire metropolitan areas or for "true cities" as defined by dense and continuous settlements.

Nor is it the large cities that are adversely affected by rigid boundaries. We cannot as yet specify this in detail, but it seems likely that the older pattern of growing "up" has been replaced by a pattern of growing "out," and therefore across established boundaries. Even small towns now find that their central business districts are being established on the outskirts in the form of shopping centers and office concentrations. It seems likely that there is a direction to this kind of growth since shopping centers are often put in or near the areas of highest income and along a major highway. It may also be true that the establishment of low-income areas near the central business district hastens the abandon-

ment of the central business district and gives to the town an eccentric pattern of growth, even though the geography of the area would have made concentric growth practical. This also has the effect of advancing the time at which the area spreads across a boundary line and creates problems which only annexation can solve.

In summary, annexation has been and will continue to be an important factor in the growth of population and in the economic development of cities and towns of all sizes. The great rigidity of local boundaries in the Northeast contributes much to the difficulties of government and of development in this area and accentuates the advantages of the rest of the country, particularly the South and the West.

## 5. Growth of Urbanized Areas

Martin L. Levin      William W. Pendleton

### 5.1 INTRODUCTION

Explicitly recognizing the emergence of large urban complexes spreading hundreds of square miles around large cities, the Bureau of the Census determined that the definition of the urban population it had employed prior to the 1950 Decennial Census of Population and Housing did not completely reflect the process of urbanization and failed to chart adequately the growth of such urban complexes.

To distinguish more accurately the urban from the rural population in the vicinity of these conurbations, the Bureau introduced the concept of an *urbanized area* comprised of a *central city* and an *urban fringe*. Defined according to sociologically rather than politically relevant criteria, the urbanized area was designed as a statistical aggregate to be more reflective of the actual urban condition than previously employed concepts.\*,<sup>1</sup>

### 5.2 THE PROLIFERATION OF URBANIZED AREAS

One hundred fifty-seven such urbanized areas were identified in the conterminous United States, Alaska, and Hawaii for the 1950 census.<sup>†</sup> These areas contained 69,252,234 persons or 45.1% of the total population of 151,325,798. In the 1960 census, 213 areas were defined as urbanized (see Fig. 5.1). The total U.S. population had increased 18.5% to 179,323,175 persons, while, through the emergence of the new urbanized areas and the growth of those previously defined, the urbanized population grew to 95,834,251<sup>‡,2,3</sup> — an increase of 38.5% over 1950 and representing 53.4% of the total population. The number of urbanized areas increased to 248 as of the 1970 Decennial Census of Population and Housing (see Fig. 5.2) and contained 118,446,466 persons, an increase of 23.6% over the urbanized area population in 1960. This compares with a growth in population for the country of only 13.3% to 203,211,926.<sup>§</sup> Figure 5.3 displays the population growth from 1950 to 1970 for both the urbanized and nonurbanized areas. As shown, the number of persons living outside urbanized areas

remained relatively constant over the period from 1950 to 1970, indicating that the urbanized areas absorbed nearly all the population growth over the past two decades.

In all of the last three decennial censuses, the majority of the urbanized population resided within the central cities of the urbanized areas. However, as may be seen in Fig. 5.4, the population in the urban fringes grew more rapidly than that in the central cities. Over the 20-year period, the population residing in the central cities of urbanized areas grew from 48,377,240 to 57,966,093 in 1960 to 63,921,684 in 1970. This represents a percentage increase of 19.8 from 1950 to 1960 and of 10.2 from 1960 to 1970. By contrast the population residing in the urban fringes nearly doubled from 1950 to 1960, increasing from 20,874,994 to 37,868,158 and by 1970 had grown to 54,524,882. The percentage increases were 81.4 from 1950 to 1960 and 44.0 from 1960 to 1970. In other words, in 1950 approximately 70% of the population residing in urbanized areas lived in central cities, whereas this percentage dropped to 60 by 1960 and to 54 by 1970.

\*The precise definition of the urbanized area concept along with an historical tracing of its development may be found in the more comprehensive report from which this summary is drawn.

<sup>†</sup>The urbanized areas under study here are those in the 50 states plus the District of Columbia. Four urbanized areas in Puerto Rico are not included.

<sup>‡</sup>The figures for 1960 and 1970 urbanized area totals, unless otherwise noted, are the revised figures published in U.S. Census of Population: 1970, Number of Inhabitants, United States Summary. The 1950 urbanized area totals, also revised from their initial publication, were taken from U.S. Census of Population: 1960, vol I.

<sup>§</sup>The total count of 203,211,926 in the 50 states and the District of Columbia is the unrevised total provided by the Census Bureau prior to final corrections. The corrected total is 203,235,298. However, the former figure is the one used by the Census Bureau in its 1970 *Number of Inhabitants* (op. cit.) publication and was the one provided on the data tapes supplied by the Bureau to non-Bureau users. The Census Bureau has not announced any plans to issue corrected, machine-readable counts.





ORNL-DWG 72-2786

Urbanized vs Non-Urbanized Population, United States 1950-1970.

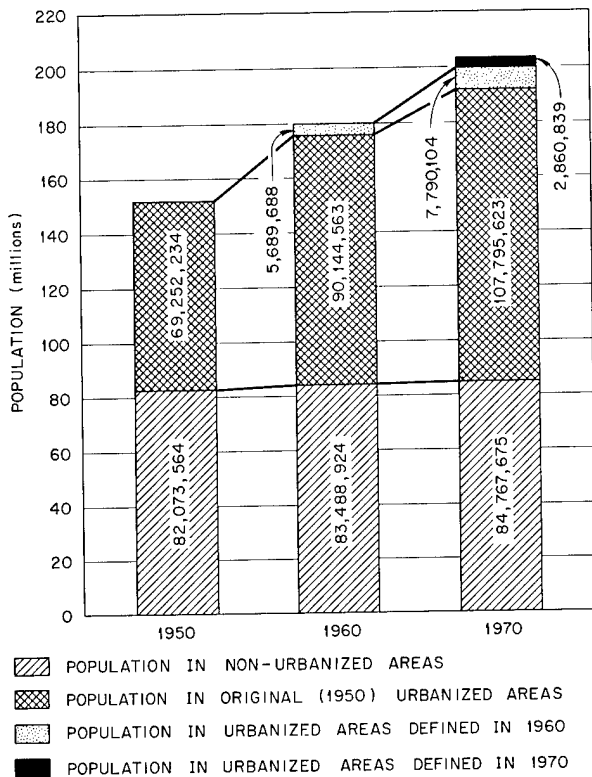

Fig. 5.3. Urbanized vs Nonurbanized population, United States, 1950-1970.

Clearly, just as the bulk of the growth in population of the country as a whole can be attributed to growth of the urbanized population, the bulk of the growth of the population in urbanized areas took place in the urban fringes rather than the central cities. Consequently, the proportion of the total population residing in the central cities of urbanized areas has remained remarkably constant: 31.1% in 1950, 32.3% in 1960, and 31.9% in 1970.

The land areas which contained the urbanized population exhibited similar increases. The original areas covered 12,804.6 square miles. Due to the increase in the number of urbanized areas and the expansion of the previously defined areas, by 1960 the urbanized land area (24,978.5 square miles) had increased 95.1% over 1950. Again, the addition of new areas and the growth of those already established brought the 1970 figure to 35,080.8 square miles, nearly three times the 1950 area and an increase of 40.5% over 1960. As was the case for population growth, the bulk of the growth in urbanized

ORNL-DWG 72-4197

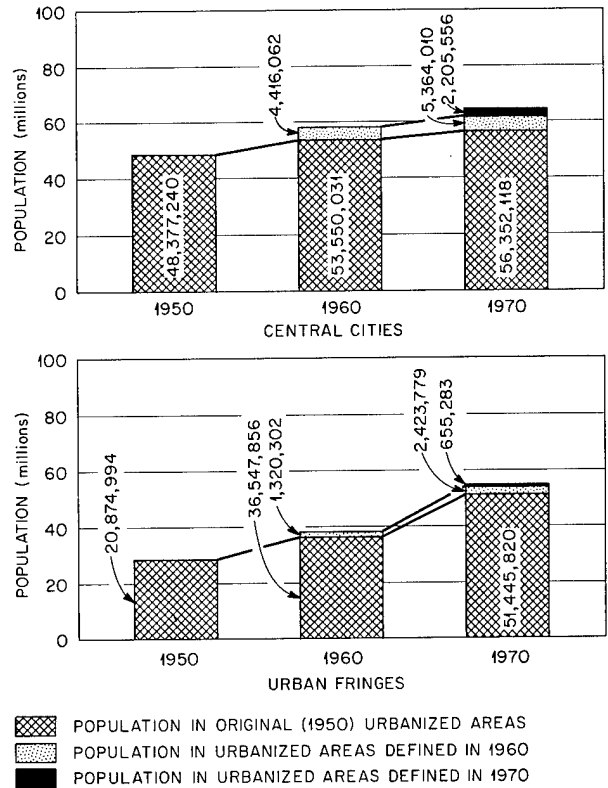

Fig. 5.4. Urbanized population in central cities and urban fringes, 1950-1970.

land area came in the fringes. In 1950, the land devoted to urbanized areas was split almost evenly between the urban fringes and the central cities, with the cities covering 6213.2 and the fringes 6591.4 square miles, or 48.7% of the urbanized land area devoted to the central city.

By 1960, the percentage of the urbanized land area covered by the central cities dropped to 42.4, as proportionally still more of the urbanized land area was devoted to the urban fringe. By 1960, the land area in the fringe increased to 14,443.9 square miles, while the central city land area increased only to 10,534.6 square miles. The 1970 census recorded an increase in central city land area of 36% to 14,323.6 square miles, while urban fringe area increased 43.7% to 20,757.2 square miles. The percentage of urbanized land area devoted to central cities decreased as a consequence to 40.3. Clearly, as with population, the larger portion of the growth in land area took place in the fringe, as Fig. 5.5 portrays graphically.

It is important to note, however, that as dramatic as this growth of land area since 1950 may appear, the

## Urbanized Land Area 1950-1970.

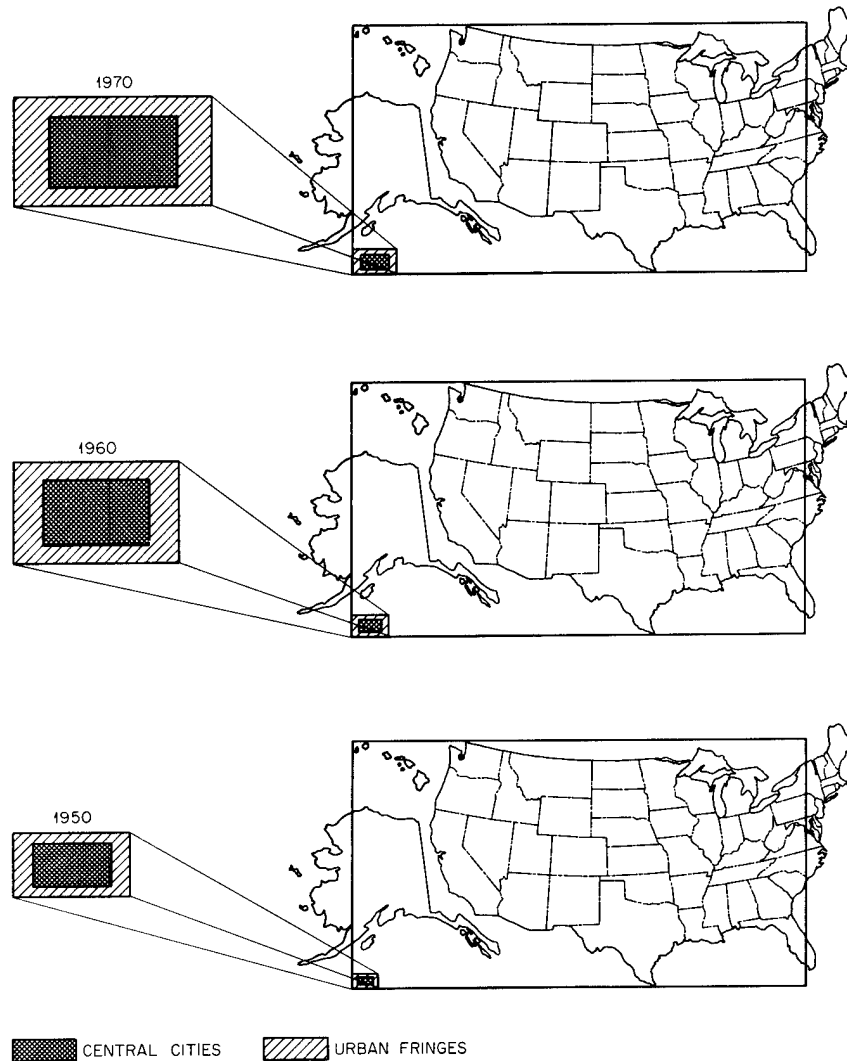

Fig. 5.5. Urbanized land area, 1950-1970.

actual proportion of the total land area of the United States which is urbanized is quite small. The total land area of the conterminous United States plus Hawaii and Alaska is 3,615,210 square miles. Thus, in 1950, only 0.35% of the total land area was urbanized. And while the absolute amount of urbanized land area nearly doubled between 1950 and 1960, still less than 0.7% of the total land area was urbanized; even in 1970 less than 1% of the total land area (0.97%) was urbanized. This trend is also depicted in Fig. 5.5.

In spite of this great concentration of population, nearly 60% of the total population in the country residing on less than 1% of the land area, the geographic

spread of the urbanized areas has proceeded at a rate more rapid than their population growth, as evidenced by declining population densities within the urbanized areas themselves. Using the overall population and land area figures to compute aggregated population densities within the urbanized areas, it is seen that the population densities have been declining in the overall urbanized areas and especially in the central cities (Fig. 5.6). For the urbanized areas as a whole, the aggregate population density has declined from 8.45 persons per acre in 1950 to 6.0 persons per acre in 1960 and 5.3 persons per acre in 1970. The most dramatic decrease came in the density of the population residing in the

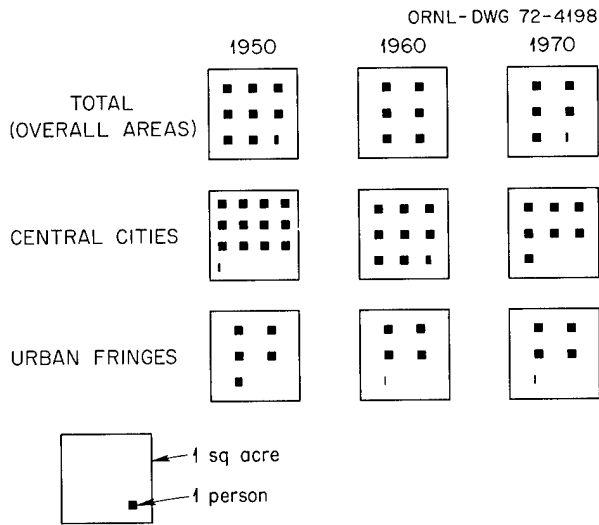

Fig. 5.6. Aggregate densities for all urbanized areas, 1950-1970.

central cities of urbanized area. The aggregate density for central cities in 1950 was 12.2 persons per acre, which fell to 8.6 persons per acre by 1960 and 7.0 persons per acre by 1970. Population densities are, as one might expect, much lower in the fringe than in the central city. In 1950 the aggregate density in the fringe was 4.9 persons per acre. In 1960 the density in the fringe was 4.1 persons per acre, with the same figure again being observed in 1970. However, it should be noted that a change in the definition of the urbanized area from 1960 to 1970, excluding large areas of very low density settlement previously included, tends to inflate the 1970 densities relative to the 1960 and 1950 figures.<sup>1</sup> Thus it might be argued that had the 1960 and 1950 data been made strictly comparable to the 1970 data, a continued trend in density reduction would have been observed.

The population densities have not only been declining in the aggregate, but they have also been declining on the average.\* That is, by computing the density for *each* urbanized area, central city and fringe, and averaging these figures a trend similar to that in the aggregate is observed (Fig. 5.7). In particular, the mean density of the urbanized areas in 1950 was 7.2 persons per acre compared with 5.1 in 1960 and 4.3 in 1970. The comparable figures for the central cities are 10.8, 7.9, and 6.5. Due most likely to a minor change in definition regarding extended cities made in 1970,<sup>1</sup> the

\*The 1960 and 1970 data upon which these computations were made were the unrevised figures. The 1950 figures were those revised in 1960. In all instances, revisions were minor.

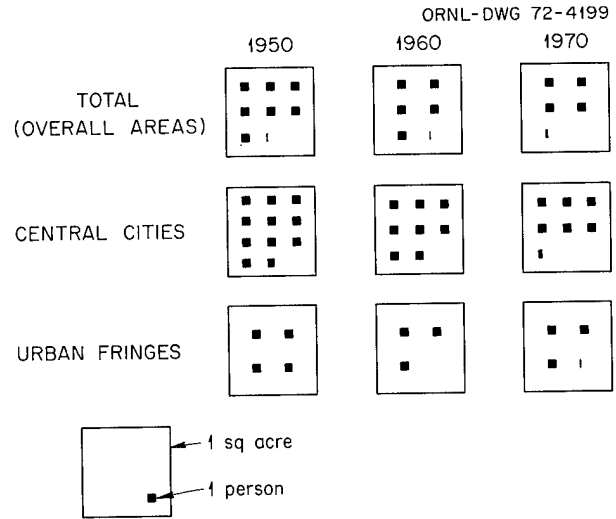

Fig. 5.7. Average densities for all urbanized areas, 1950-1970.

mean densities of the fringes show a slight increase from 1960 to 1970 along with a decrease from 1950 to 1960: 3.8 for 1950, 3.0 for 1960, 3.1 persons per acre for 1970.

Overall, then, the aggregate trends are as follows: The number of urbanized areas, their population, and their land areas all increased between 1950 and 1970. The percentage of the total population residing in urbanized areas has increased from 45.1 in 1950 to 53.8 in 1960 to 58.6 in 1970, while the urbanized land area almost tripled over this period from 12,804.6 to 35,080.8 square miles. Still, the land area upon which such a large proportion of the population resides represents only a small percentage of the total land area, 0.35% in 1950 and 0.97% in 1970. In other words, in 1970 58.6% of the population of the 50 states in the nation and the District of Columbia lived on a land area slightly less than that of the state of Indiana. But the proportional increase in land area devoted to urbanized areas has increased more rapidly than the proportional increase in population, as evidenced by a declining population density from 8.45 persons per acre in 1950 to 5.3 persons in 1970.

Most of the increase in population and area has taken place in the urban fringes rather than the central cities. Indeed, the proportion of the total population resident in central cities of urbanized areas has remained essentially constant from 1950 through 1970, ranging between 31.1 and 32.6%. However, the proportion of the urbanized area population residing in the urban fringes has increased steadily, from 30.4% in 1950 to 39.6% in 1960 to 46.9% in 1970. At the same time the

proportion of the urbanized land area which is devoted to central cities has declined as well, from 48.7 to 42.4 to 40.3%. Indeed, the ratio of aggregate population density in the central city to that in the urban fringe has declined from 2.45 in 1950 to 2.09 in 1960 to 1.69 in 1970.

This concentration of population in urbanized areas and the apparent redistribution of the urbanized population from the central cities to the fringes are further documented by examining the growth patterns of the individual areas. Between 1950 and 1960, only 5% of the urbanized areas lost population. However, 32% of the central cities of urbanized areas lost population during this period as compared with only 12% of the fringes. From 1960 to 1970, 14% of the 1960 urbanized areas lost population, but 43% of the central cities lost population, while 12% of the fringes exhibited a decrease in population. It is true that the central cities are more "bounded" by local political considerations, and their ability to grow in area, at least, is constrained by their ability to annex territory.<sup>4</sup> Nonetheless, it seems clear that the increase in population in the fringes, probably due both to the addition of newly defined urbanized areas and the growth of territory and population in existing areas, accounts for most of the growth of the urbanized areas.

### 5.3 THE GROWTH OF ESTABLISHED URBANIZED AREAS

Examining separately the original urbanized areas (those first defined in 1950) across the 20-year interval from 1950 to 1970, the trend toward concentration of the population in urbanized areas is still more dramatically portrayed. For example, in 1970 the 155 urbanized areas (the original 157 minus consolidations plus separations) alone contained 107,797,938 persons or 53.0% of the total population (Fig. 5.3). That is, ignoring the areas newly defined as urbanized in 1960 and 1970 and looking only at the growth over 20 years of the original areas, in 1970 these areas contained 53.0% of all persons in the 50 states, up from 50.2% in 1960 and 45.1% in 1950. In addition to a greater concentration of persons living in all urbanized areas in 1970 (as shown above), there has been a disproportionate population growth in the original urbanized areas.

However, while this growth was taking place in the overall urbanized areas, the central cities of these areas grew less rapidly (Fig. 5.4). Indeed, 31.1% of all persons lived in the central cities of the original urbanized areas in 1950, but this proportion fell to 29.9% in 1960 and

to 27.7% in 1970. The number of inhabitants in these central cities increased by 10.7% from 1950 to 1960 and only 5.2% from 1960 to 1970. At the same time these urbanized areas, as a whole, increased in population by 30.1% from 1950 to 1960 and 19.6% from 1960 to 1970, due primarily to the large increases in the urban fringes of 75.1% from 1950 to 1960 and 40.8% during the next decade.

The land areas covered by these original urbanized areas also grew, and for the most part grew disproportionately faster than the population, as evidenced by what had happened to the aggregate densities in these urbanized areas (keeping in mind the definitional change involving densities referred to earlier). Overall, the aggregate densities of these areas declined from 8.5 persons per acre in 1950 to 6.2 in 1960 and 5.5 in 1970

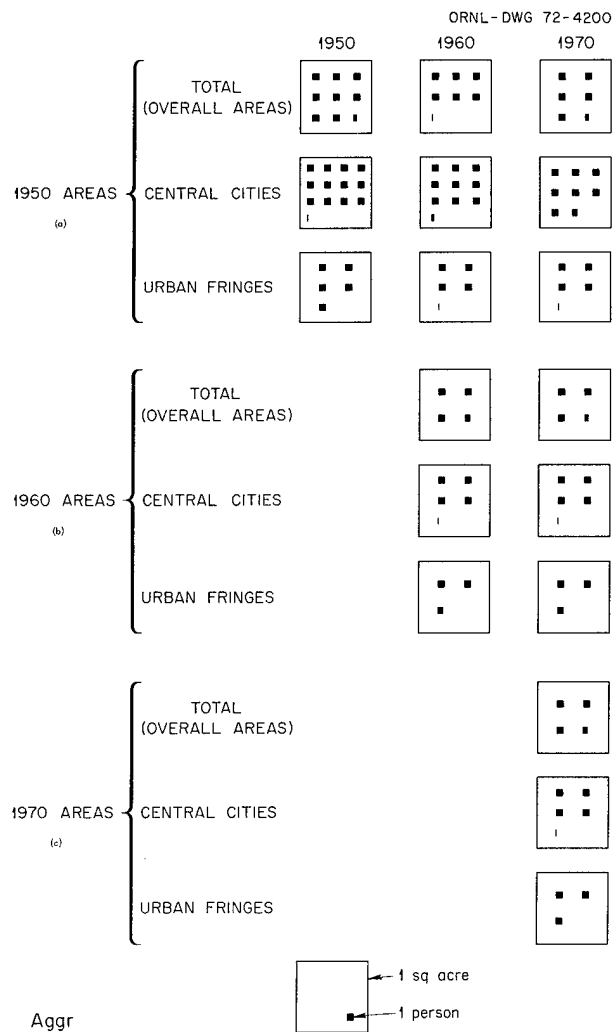

Fig. 5.8. Aggregate densities for 1950, 1960, and 1970 urbanized areas.

(Fig. 5.8a). The dramatic drop seemed to come in the central cities, where the densities declined from 12.2 persons per acre in 1950 to 9.4 in 1960 and 7.7 in 1970. The fringe density dropped from 4.9 persons per acre to 4.17 from 1950 to 1960 but rose slightly in 1970 to 4.22 persons per acre.

The reduction in the growth rate of these areas would perhaps portend a reversal of the trend toward population concentration in urbanized areas were it not for the fact that new urbanized areas were emerging. Interestingly, those added in 1970 had much lower aggregate densities than the original 155 areas — 3.6 persons per acre for the overall area; 4.1 and 3.0 persons per acre for the central cities and the fringes, respectively (Fig. 5.8c). Similarly, those which were added in 1960 initially had lower densities than the original areas, the figures for the overall areas, central cities, and fringes being 3.8, 4.2, and 2.8 persons per acre, respectively (Fig. 5.8b). Moreover, the growth rate for areas added in 1960 during the sixties was greater than that for the original urbanized areas during the same period. Those which were added in 1960 had a percentage increase in population between 1960 and 1970 of 35.7% overall (Fig. 5.3), while the central cities grew 21.5% and the fringes grew a whopping 83.5% (Fig. 5.4). Therefore, it appears that while the growth of the older areas may be slowing down (i.e., they appear to have grown at a slower rate) the growth rate of the newly added areas is nearly double that for the older areas, and there is nothing to suggest that such growth might not be expected to continue — not only for those added in 1960, but also for those added in 1970. The densities of the 1960 areas, however, did not change significantly over the decade and consequently looked like the densities of the newly included areas (Fig. 5.8b).

#### 5.4 CONCLUSIONS

In spite of the increased concentration of the U.S. population into urbanized areas or conurbations and in

spite of the increased clustering of population around cities, the denseness of the urbanized population has been decreasing on the whole, especially in the central cities. Whether or not this trend will continue over the next decade is a question worthy of consideration.

The implications of this change in density need close scrutiny from several perspectives. Are these density patterns differentially experienced by various segments of the population? For example, the percentage of the urban fringe population which is nonwhite has remained more or less constant from 1950 through 1970 at about 5%, while the percentage of central city inhabitants who are nonwhite has increased steadily from 13.1 to 22.5%. This becomes all the more crucial when it is realized that as of 1970 more than two-thirds of all nonwhites resided in urbanized areas. The social and demographic consequences of density differentials within urbanized areas also need attention. Are they related to crowding, and how are these related to various social pathologies? And, finally, those areas newly defined as urbanized need special analytical attention in an attempt to understand on an ecological level the antecedents of urbanization.

#### REFERENCES

1. Martin L. Levin and William W. Pendleton, *The Growth of Urbanized Areas*, ORNL-HUD-5 (in preparation).
2. U.S. Bureau of the Census, "Number of Inhabitants, U.S. Summary," *U.S. Census of Population: 1970*, Final Report PC(1)-A1, U.S. Government Printing Office, Washington, D.C., 1971.
3. U.S. Bureau of the Census, "Number of Inhabitants," *U.S. Census of Population: 1960, Characteristics of the Population*, vol I, Part A, U.S. Government Printing Office, Washington, D.C., 1961.
4. E. S. Lee, "How Cities Grow," *Excerpts from the Civil Defense Research Project Annual Report, March 1971–March 1972*, Oak Ridge National Laboratory (in preparation).

## 6. Social Security Data and Urban Growth Patterns

Kathryn P. Nelson

### 6.1 INTRODUCTION

The usefulness of the Social Security Administration's One Percent Sample of those in covered employment\* for studying urban growth patterns was introduced in last year's annual report.<sup>1</sup> The growth of 35% in the Atlanta labor force between 1962 and 1967 was shown to result largely from an excess of new entrants over retirees, with net in-migration playing a smaller role. Changes in employment patterns by sex and race, the most important of which was the 82% growth rate for black females, were detailed, as were shifts in the industrial mix of the city. The utility of the data for measuring economic returns to migration was also explored, and it was found that interstate migrants have larger percent increases in income than nonmigrants.

Use of the data has since been expanded in three directions:

1. The Atlanta data have been used to gain additional information on intrametropolitan dynamics, examining the processes and effectiveness of labor mobility within the Standard Metropolitan Statistical Area (SMSA), as well as the spatial redistribution of employment between central and ring counties.
2. The CWHS information about specific county of location at any time for those in covered employment has been exploited to identify migration streams between Atlanta and the main geographical regions of the United States.
3. Equivalent data on labor force growth and change in Cleveland, Philadelphia, St. Louis, San Francisco, and San Jose are being examined. Thus, comparison of similarities and differences among the six is possible.

Here we briefly describe the direction of research and the more important results in each of these areas.

### 6.2 INTRAMETROPOLITAN DYNAMICS

Last year's work revealed that the impressive amount of movement in and out of covered employment meant that only 45% of those working in Atlanta in 1967 were holdovers from the 1962 Atlanta labor force. The processes of labor mobility within Atlanta have been studied further, since the effectiveness of the labor mobility mechanism in allocating jobs and earnings among growing and decreasing industries and areas and among the various race and sex groups is of interest to those studying cities and their attractiveness to migrants. By defining "industrial mobility" very crudely as having occurred for those workers whose major industry of employment<sup>†</sup> changed in the five-year period, we find that 110,000 of the 290,000 who worked in Atlanta in both years were industrially mobile. Thus, only 28% of Atlanta's 1967 work force had possibly remained in the same job, and many of these people may well have changed jobs within the same industry.

Blacks and the young were the most likely to have changed industry while remaining in Atlanta. More than half of the blacks, both male and female, remaining in Atlanta in the period changed industry, while only one-third of the whites changed industry. As with geographic mobility, it is the young who are more likely to be industrially mobile: 65% of those under age 25 changed industry during the period as compared with 22% for those over 45.

The incidence of voluntary and involuntary mobility among different groups was also examined. Positive correlations between the net flows of labor to industries and the earnings level of the industry of destination for only the young suggested to Gallaway<sup>2</sup> that voluntary labor mobility is most common for males aged less than 25, while involuntary job separation explains increasingly more of total mobility for workers as they become older. This general pattern characterized black males as well as white males, except that involuntary

---

\*Continuous Work History Sample (CWHS).

---

<sup>†</sup>Defined as two-digit SIC code.

Table 6.1. Change in average income by age, race, and industrial mobility for males in covered employment in Atlanta in both 1962 and 1967

Age in 1962	Same major industry			Major industry changed				
	No.	Mean income 1962	Mean income 1967	Percent increase	No.	Mean income 1962	Mean income 1967	Percent increase
<b>White males</b>								
<25	100	3450	6400	85	194	2270	5610	147
25-44	582	6680	9290	39	239	4830	7550	56
45+	329	7060	8920	26	95	5010	5120	2
<b>Black males</b>								
<25	26	2270	3940	73	69	1420	3530	150
25-44	82	3230	4840	50	102	2320	3750	62
45+	80	3050	3740	23	34	2170	2680	23

mobility was an especially serious problem for black males in the age group 25 to 34.<sup>3</sup> Since our data contained income for both periods, percentage change in average income was calculated for white and black males in three broad age groups who did and did not change industry. The pattern revealed by these data (shown in Table 6.1) is similar to that hypothesized by Galloway. Industry changers have larger increases in income than those who remain in the same industry for the youngest age category for both black and white males, while, for the oldest groups, industry changers do less well. Of especial interest is the indication that black males in the 25 to 44 age bracket appear to gain as much percentagewise through industrial job mobility as white males in that age bracket, although their absolute level of income is less. This would indicate that the labor market in Atlanta was functioning more equitably for blacks during this period than Galloway's findings for the nation in 1957 and 1960 would suggest.

Information concerning changes in the spatial distribution of employment within the metropolitan area was also extracted from the CWHS. Studies of employment shifts between central and suburban areas which use cross-sectional data such as *County Business Patterns* can show change over time, but reveal little of how such change came about. Thus, the broad picture of spatial redistribution of employment in Atlanta between 1962 and 1967 shown by the Social Security data is similar to that drawn from *County Business Patterns* data for the 1964 to 1969 period.\* The Social Security data indicate that as employment grew in the Atlanta SMSA from 1962 to 1967, the share of employment of the central county (Fulton) decreased

from 78 to 74%. Fulton County's percent share of employment declined for three of its five most important (largest) industrial categories: manufacturing, wholesale trade, and retail trade; only for services and for transportation and public utilities did it maintain its relative share of the market. The suburban counties increased their relative shares of metropolitan employment in the areas of manufacturing and retail trade.

Moving beyond such findings, however, the Social Security data permitted further examination not only of the personal characteristics but also of the patterns of labor mobility responsible for the outward redistribution of employment.

For example, the age composition of the covered labor force within the ring counties shifted during the five-year period toward the pattern considered typical of suburbia: in 1967 all suburban counties had higher than average shares of those under age 45 and lower than average shares for those over 45. The opposite pattern prevailed in the central county. In 1962, Fulton County's labor force had an age distribution almost typical of that of the SMSA as a whole, but by 1967 its relative share of those aged 25 to 44 had decreased, while the share of both the old and the young grew. Such gains for those under 25 were almost completely due to the large influx of young black females, since young white males are particularly underrepresented in the central county. Only 67% of white males working in the SMSA with age less than 25 worked in Fulton County, whereas 74% of all white males in the SMSA labor force worked there.

Seeking to examine the processes by which such differential changes were accomplished, we find that proportionally more of the new entrants during the period found employment in the suburban counties, and, as age structure might suggest, proportionately

\*See "Changes in the Concentration of Manufacturing in Metropolitan Areas," C. H. Patrick, this report.

fewer of the retirees were from the suburban counties. Employment changes among the 290,000 who worked in the SMSA in both years resulted in a net shift of three percentage points outward from Fulton County, paralleling the overall redistribution of employment during the period.

The effects of migration upon the process of spatial redistribution were mixed. Migrants moving into the Atlanta SMSA from the rest of Georgia dispersed among the five counties in approximately the same ratio as total 1967 employment. For longer-distance migrants, however, the situation was different. About 80% of interstate migrants found employment in Fulton County, while DeKalb County appeared to be the next most attractive location. The three other ring counties had relatively higher rates of long-distance out-migration from their 1962 labor pool, and thus, in net, lost their relative share of SMSA employment through long-distance migration.

To summarize, it would appear that the observed redistribution of employment outward from Fulton County was due to new entrants into the labor force and stayers in Atlanta. The net result of interstate

migration alone would have led to further employment growth for the central county.

### 6.3 INTERREGIONAL MIGRATION

Figure 6.1 illustrates another of the many ways in which the Social Security data can illuminate the effects of labor mobility upon a metropolitan area. Streams of migration between Atlanta and regions in the rest of the nation and the resulting net migration are shown there. As is usually the case, the total number of migrants between Atlanta and any region was much greater than the net redistribution of population accomplished by such streams. The effectiveness of migration, defined as:

$$\frac{|\text{in} - \text{out}|}{\text{in} + \text{out}}$$

was greatest in redistributing people from the other southern states to Atlanta. To the extent that Atlanta's work force grew through net migration, it can be seen that the favorable balance was supplied largely by

ORNL-DWG 71-12398

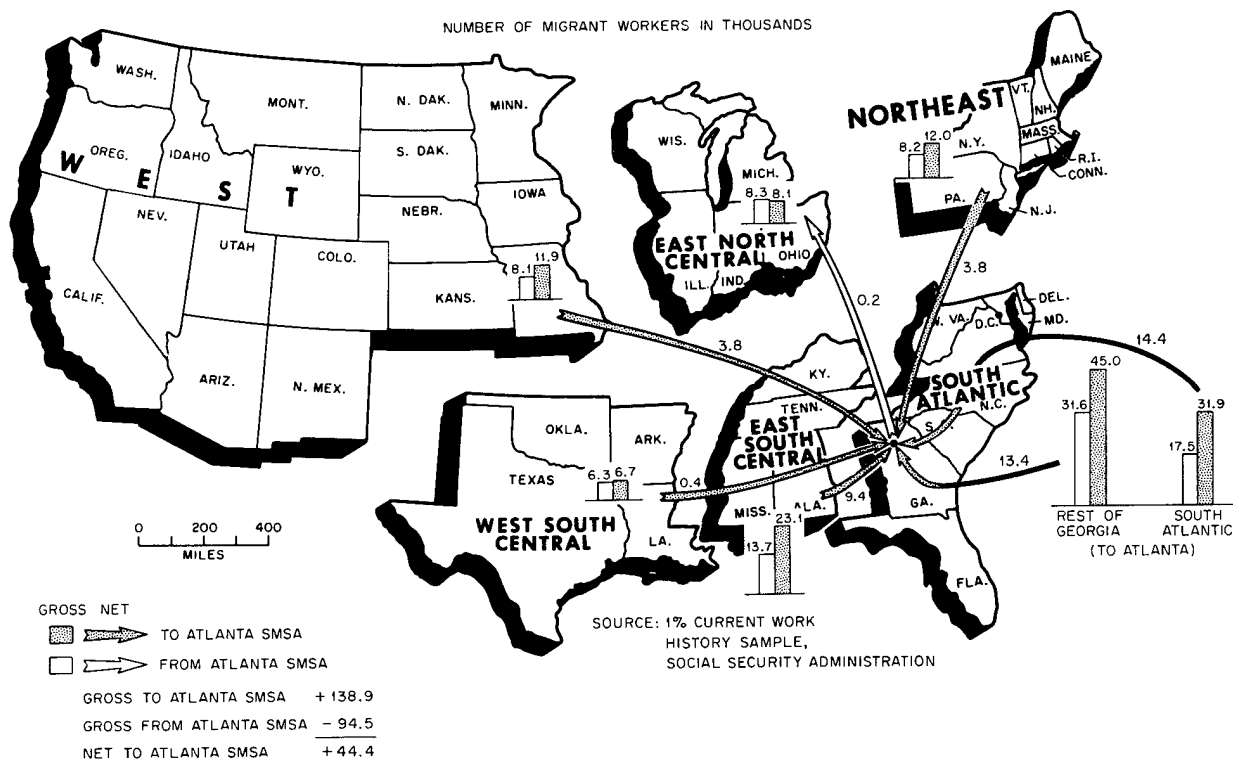

Fig. 6.1. Migration streams to and from Atlanta, 1962 and 1967.

interchange with the South, and only marginally by net in-migration from the northeastern and western states. Atlanta's attractiveness relative to the rest of the country is suggested, however, by the lack of significant net out-migration to any region. Net in-migration into Atlanta also characterized all sex, race, and age groups, except for nonwhite males aged 18 to 24.

#### 6.4 LABOR FORCE CHANGES: COMPARISONS FOR SIX MAJOR CITIES

Material in the areas of intrametropolitan dynamics and intermetropolitan migration streams has been prepared for the other SMSAs studied with Social Security data. The six cities of Atlanta, Philadelphia, Cleveland, St. Louis, San Francisco, and San Jose are compared here only in terms of gross changes in labor force size and composition during the five-year period 1962 to 1967.

As Fig. 6.2 indicates, rates of growth in employment were very different for the six cities. The labor forces of Atlanta, San Jose, and San Francisco grew at rates higher than the national average, while Philadelphia, Cleveland, and St. Louis had slower rates of growth. Although San Francisco, with near average growth rate and net in-migration, is not as easily classified, the six cities in this sample fall into two groups that may be roughly characterized as: (1) more vigorous, faster growing employment centers and (2) older, slower growing cities. As Fig. 6.2 also shows, in all six SMSAs the increase in the number of workers in covered

employment was greater than the increase in population.

Atlanta, San Francisco, and San Jose all grew through both new entrants and net in-migration. However, net out-migration, both intrastate and interstate, characterized the Cleveland, Philadelphia, and St. Louis SMSAs for all sex and race groups. Unlike the experience in Atlanta, holdovers from the 1962 labor force constituted the major portion of the work force in 1967 for the three older, slower growing cities. For example, 64% of the white males in Philadelphia in 1967 were also there in 1962. As we found with Atlanta, for all six SMSAs the net change due to those entering and leaving the labor force played a more important role in the growth in labor force than did net migration.

For all the cities except San Jose, blacks, both male and female, were less mobile than their white counterparts and thus were more likely to remain in covered employment in the SMSA. There were large numbers of new entrants among black females for all cities, thus increasing black females' share of the labor force most sharply, while white male employment grew most slowly. In St. Louis and in Cleveland, the number of white males employed in 1967 was not significantly different from that shown for 1962. The similarity in growth experience of Cleveland and Philadelphia is indicated also by changes in their age profiles. In both, the percentage of workers over 45 was large ( $>27\%$ ) and increased during the period. The percent of labor force over 45 fell slightly from 27% in San Francisco and St. Louis, and only San Jose, the fastest growing city, had as few people over 45 and as many under 25 as did Atlanta.

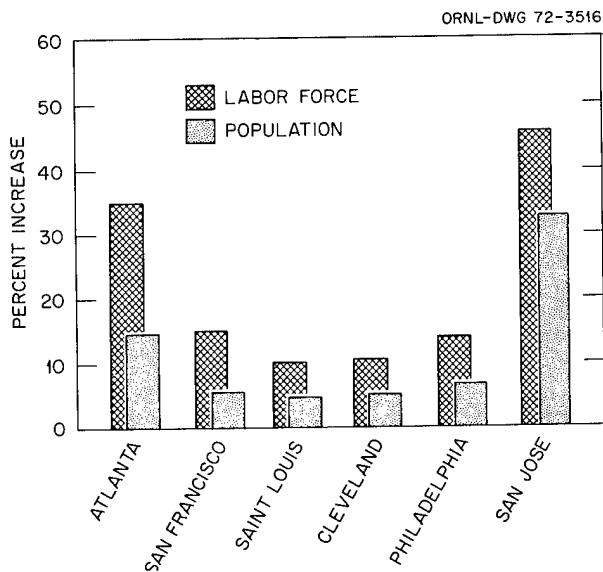

Fig. 6.2 Increase in population and in labor force, six SMSAs, 1962-1967.

#### 6.5 CONCLUSIONS

As the birth rate drops and spatial differences in the rate of natural increase decline, variations in urban and regional growth depend increasingly upon the patterns of migration within the United States. Moreover, it has been shown that the migration process is strongly related to the availability of employment opportunities, and that the model of migration as an economically rational activity is a useful one.

Thus, Social Security data, with its ability to follow a sample of individuals in the covered work force through both geographical and industrial movement, provides a most fruitful approach to the study of urban growth patterns. This report summarizes our experiments with possible uses of the data for the study of inter- and intrametropolitan labor mobility. Such findings as those about the suburbanization of employment, the

monetary returns of labor mobility, migration streams to and from cities, and growth of metropolitan labor forces, when extended to all the major U.S. metropolitan areas, will greatly increase understanding of the urban growth process.

#### REFERENCES

1. E. S. Lee, "Components of the Atlanta Labor Force, 1962 and 1967," *Urban Growth Patterns Re-*

*search Excerpts from the Annual Progress Report, Civil Defense Research Project, March 1970-March 1971, ORNL-4679.*

2. L. A. Gallaway, "Interindustry Labor Mobility in the U.S. - 1957 to 1960," *Research Report No. 18, Office of Research and Statistics, Social Security Administration, Washington, D.C., U.S. Government Printing Office, 1967, pp. 40-41.*

3. *Ibid.*, pp. 82-83.

## 7. Changes in the Concentration of Employment in Metropolitan Areas, 1964-1969

Clifford H. Patrick

### 7.1 INTRODUCTION

The decentralization of employment poses problems for cities in many ways similar to those caused by the decentralization of population. Indeed, a primary reason for studying shifts in the concentration of employment is to determine the relationship of employment changes to population shifts. This paper, which reports on the changes in the concentration of employment between 1964 and 1969, represents the initial phase of study of this relationship. The paper first discusses studies of trends in the location of employment to 1964 and then examines employment shifts in 33 metropolitan areas from 1964 to 1969. Altogether, this study presents an overall view of the degree of decentralization in employment which has been occurring in the U.S.

### 7.2 TRENDS IN THE LOCATION OF EMPLOYMENT PRIOR TO 1964

Recent studies have indicated that industrial employment in the U.S. has been shifting from the central cities to the suburbs and from the Old Manufacturing Belt of the Northeast and Great Lakes regions to the South and West. Daniel Creamer has written what is perhaps the best known study of trends in the location of employment.<sup>1</sup>

Creamer found the national trend from the turn of the century to 1958 to be a decline in the share of manufacturing employment found in principal cities of major industrial areas offset by an almost equal increase in the share found in the suburbs of these cities. His further analysis of data to 1963 indicated that the trend had continued but at a faster pace. He found that between 1958 and 1963, the share of manufacturing employment located in the principal cities of major industrial areas declined to 28% of the national total, while the share located in the suburbs of these cities increased to 29%, becoming for the first time greater

than that located in the cities. This occurred in part because the cities lost 338,000 workers between 1958 and 1963, while the suburbs gained 443,000 workers.

Creamer also noted changes in the regional distribution of employment in this period. He found the Old Manufacturing Belt had declined from 79% of the national total of manufacturing employment in 1929 to 68% in 1958. From 1958 to 1963, this trend continued as the share of manufacturing employment in the Old Manufacturing Belt decreased another 2% to 66%. During this five-year period, the Southeast's share increased from 13 to 15%, and the Southwest's share grew from 12 to 13%. Creamer's study is perhaps the most comprehensive to date showing the dual nature of trends in employment changes, that is, both intrametropolitan and interregional shifts.

The Advisory Commission on Intergovernmental Relations (ACIR) has completed studies of a similar nature.<sup>2</sup> With employment data for 18 large Standard Metropolitan Statistical Areas (SMSAs) from 1958 to 1963, the ACIR found absolute declines in manufacturing employment in the core counties in seven SMSAs. In 17 of the 18 SMSAs manufacturing employment increased, and in 11 of 18 employment in the core increased; in five of the seven SMSAs which experienced declines in employment in the center, growth in employment in the suburbs was insufficient to offset these losses, resulting in an overall negative growth for these five SMSAs.\* In only one SMSA, Pittsburgh, did employment decline in both core and suburban areas. In Minneapolis-St. Paul and New Orleans, growth in manufacturing employment in the core was greater than growth in the suburbs. Overall, these results substantiate Creamer's findings on the intrametropolitan dispersion of employment to 1964.

The ACIR also examined the regional trends in employment. Between 1940 and 1960, secondary

---

\*These were: New York, Boston, Pittsburgh, Baltimore, and St. Louis.

industry grew at a slower rate in the traditional Manufacturing Belt compared with the remainder of the country. New England, the Mideast, and the Great Lakes regions experienced declines in their shares of national employment in secondary industry, while the share of all other regions grew. In 1940, these three regions contained 64.4% of the nation's secondary industry employment; in 1960 they contained 56.9%. The Far West, Southeast, and Southwest gained most during this period; the Far West increased its share from 6.9 to 10.8%, the Southeast from 17.5 to 18.5%, and the Southwest from 4.1 to 5.8%. The Plains and Rocky Mountain regions both increased their share by less than 1%. These findings are similar to those of Creamer in showing the relative growth of the South and West and relative decline of the Northeast.

Two studies have shown that the decentralization of manufacturing employment follows the trend of population dispersion in metropolitan areas. Edwin Mills has fitted urban density functions to the geographic location patterns of population and businesses.<sup>3</sup> He found that in urban areas, "population is the least centralized, followed by manufacturing, retailing, services, and wholesaling in that order." John Kain also found this pattern of dispersal in his study of industrial shifts from 1948 to 1958 in 40 large SMSAs.<sup>4</sup> He found that the percent of the SMSA total located in the suburban ring had increased from 39 to 51% for population, from 37 to 46% for manufacturing, and similarly for retailing, services, and wholesaling, in that order. These studies tend to indicate that industry is dispersing into the suburbs and that a strong relationship between the movement of population to the suburbs and the movement of employment probably exists.

### 7.3 EMPLOYMENT SHIFTS IN THE U.S., 1964-1969

In order to determine the magnitude of more recent shifts in employment within metropolitan areas and as a preliminary step to examining the relationship of these shifts to intercensal movements in the population, 1964 and 1969 *County Business Patterns* (CBP) data for 33 multicounty SMSAs have been analyzed.\* In the

\*The 33 multicounty SMSAs are: (Northeast) New York City, Philadelphia, Boston, Pittsburgh, Newark, Paterson-Clifton-Passaic, Buffalo, Rochester; (North Central) Chicago, Detroit, St. Louis, Cleveland, Minneapolis-St. Paul, Milwaukee, Cincinnati, Kansas City, Indianapolis, Columbus; (South) Washington, Baltimore, Houston, Dallas, Atlanta, New Orleans, San Antonio, Memphis, Birmingham; (West) San Francisco-Oakland, Seattle-Everett, Denver, Portland, Sacramento, and Salt Lake City. They range in 1970 population rank size from New York City (1) to Salt Lake City (57).

absence of better intercensal data prior to receipt of the 1970 Census Fourth Count data, the CBP data allow a more up-to-date examination of shifts in employment to be made at the county level in SMSAs. These data have limitations in that a central county may contain large suburban areas as well as the central city, thus disguising to some extent movements out of the central city. Nonetheless, the county data do show in detail the redistribution in the location of employment from central to suburban counties which occurred between 1964 and 1969 in SMSAs.

In this study the analysis of redistribution has been based upon both absolute and relative changes in total employment and manufacturing employment (SIC 19-39) in the 33 multicounty SMSAs. The New York Metropolitan Region (NYMR) provides a good example of the absolute and relative change measures used in this study. In *Anatomy of a Metropolis*, Hoover and Vernon found the distribution of total employment in the 3-state, 22-county NYMR in 1956 to be as follows:<sup>5</sup>

- 64% in the five-county "core,"
- 23% in the seven-county "inner ring," and
- 13% in the ten-county "outer ring."

The 1964 CBP data show that NYMR total employment was distributed with:

- 59.8% in the "core,"
- 26.2% in the "inner ring," and
- 14.0% in the "outer ring."

Between 1964 and 1969, all 22 counties in the metro area experienced an absolute increase in employment, ranging from 1.7% in Kings County to 36.1% in Morris County, New Jersey. The core grew by 9.0%, the inner ring by 19%, and the outer ring by 28%, for an overall growth rate of 14%. Because the relative growth in employment was greatest in the outer ring and least in the core, the share of total regional employment located in each area shifted with the 1969 distribution being:

- 57% in the "core,"
- 27.2% in the "inner ring," and
- 15.8% in the "outer ring."

The significance of this change should be obvious — although the core grew absolutely by over 295,000 workers, it suffered a relative loss from 1964 to 1969 of 172,000 workers, based on its 1964 share (60%) of total regional employment. Furthermore, when the

relative loss in employment is computed using the 64.2% figure for 1956, almost 450,000 workers appear to have been redistributed from the core to the 17 suburban counties in the 13-year period, in spite of absolute growth in the core. Thus, the importance of examining both the absolute and relative growth rates in employment can be seen.

The 33 SMSAs examined in the present study experienced a 21% growth in total employment and a 15% growth in manufacturing employment. This indicates two things: (1) employment in these SMSAs grew at a healthy pace from 1964 to 1969, despite the downturn in the business cycle nationally, and (2) these SMSAs have undergone an increasing diversification of employment, as shown by the faster growth in other sectors of the economy compared with manufacturing. This diversification has occurred in both the core and the suburban ring of these SMSAs, as the differential rates of growth between total and manufacturing employment show.

As Table 7.1 shows, in the central or core counties total employment grew by 17%, while manufacturing employment grew by 11%. In the suburban counties, total employment grew by 33% while manufacturing employment grew by 24%, both rates about double those of the core counties. Of those workers added to the labor force in the 33 SMSAs in the five-year period, 61% of those in all industries and 53% of those in manufacturing located in the core. However, in 1964, 75% of all workers and 70% of those in manufacturing had been located in the core. Thus, from 1964 to 1969 the core and suburbs both experienced an absolute increase in employment, but the core gained a smaller share of employment than it previously held; the core, therefore, experienced a relative loss of employment to the suburbs (see the shaded area of Fig. 7.1).

Regional variations in employment growth have continued, as Figs. 7.2, 7.3, and 7.4 show. The Northeast, which in 1964 had the largest share of national employment and the share most evenly distributed

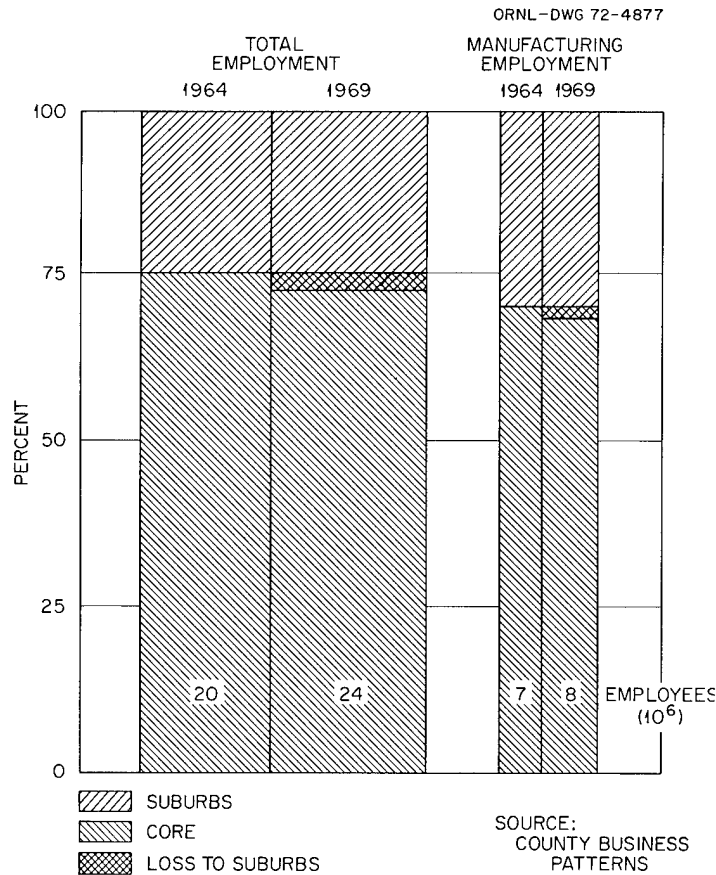

Fig. 7.1. Employment in 33 SMSAs, 1964-1969.

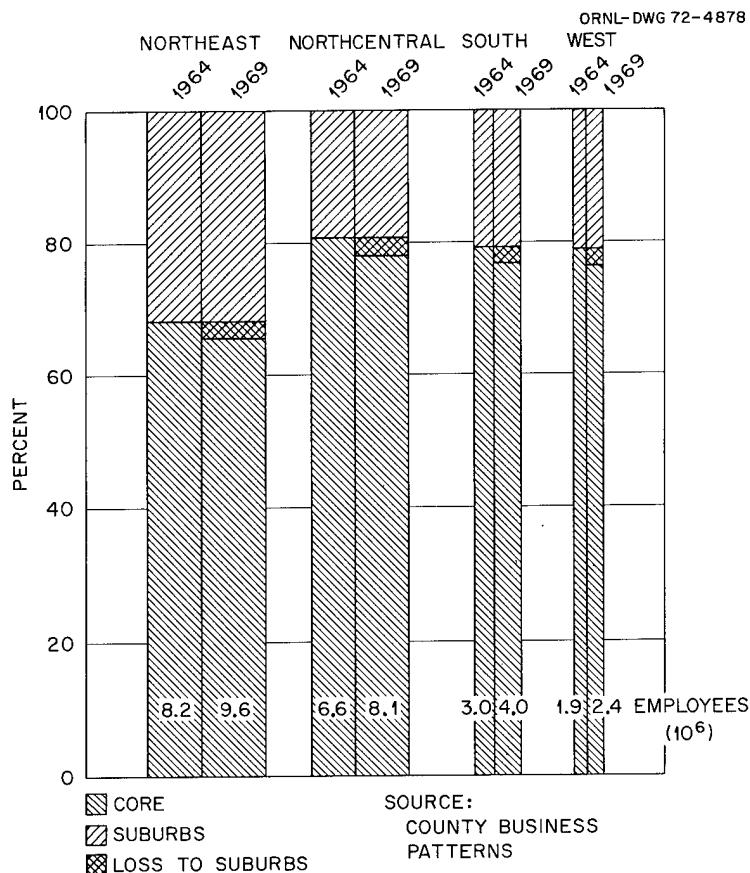

Fig. 7.2. Total employment in 33 SMSAs, by region, 1964-1969.

Table 7.1. Growth in employment in 33 SMSAs, 1964-1969

	1964	1969	Change, 1964-1969	
			Absolute	Percent
<b>Total employment</b>				
Core	14,886,792 (75.1%)	17,454,388 (72.7%)	2,567,596 (61.3%)	17.2
Suburban ring	4,945,563 (24.9%)	6,563,716 (27.3%)	1,618,153 (38.7%)	32.7
Total (33 SMSAs)	19,832,355 (100%)	24,018,104 (100%)	4,185,749 (100%)	21.1
<b>Manufacturing employment</b>				
Core	4,954,759 (70.1%)	5,492,893 (68.5%)	538,134 (52.5%)	10.9
Suburban ring	2,043,712 (29.9%)	2,530,508 (31.5%)	486,796 (47.5%)	23.8
Total (33 SMSAs)	6,998,471 (100%)	8,023,401 (100%)	1,024,930 (100%)	14.6
<b>Total employment</b>				
Northeast	8,254,506 (41.6%)	9,553,545 (39.8%)	1,299,039 (31.0%)	15.7
North Central	6,645,614 (33.5%)	8,128,767 (33.8%)	1,483,153 (35.4%)	22.3
South	3,040,975 (15.3%)	3,955,532 (16.5%)	914,557 (21.9%)	30.1
West	1,891,260 (9.5%)	2,380,260 (9.9%)	489,000 (11.7%)	25.9
<b>Manufacturing</b>				
Northeast	2,982,563 (42.6%)	3,261,793 (40.7%)	279,230 (27.2%)	9.4
North Central	2,754,131 (39.4%)	3,205,331 (39.9%)	451,200 (44.0%)	16.4
South	759,591 (10.9%)	957,544 (11.9%)	197,953 (19.3%)	26.1
West	502,186 (7.2%)	598,733 (7.5%)	96,547 (9.5%)	19.2

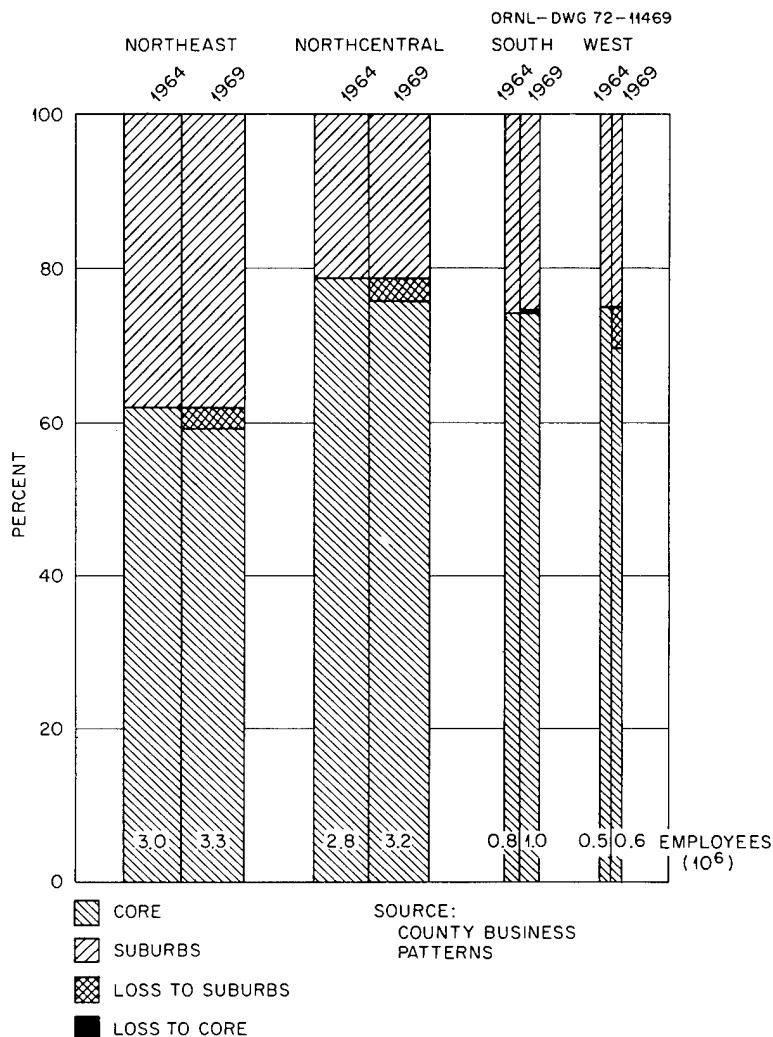

Fig. 7.3. Manufacturing employees in 33 SMSAs, 1964-1969.

between core and suburbs within SMSAs, experienced the lowest growth rates in both core and suburban employment. The other regions, all of which had 74% or more of their employment in the core in 1964, grew at rates in most cases over twice as great as those in the Northeast. Total employment in each region grew about twice as fast in the suburbs as in the core, with the fastest growth occurring in the South. Manufacturing employment also grew about twice as fast in the suburbs of each region as in the core, with one notable exception. In the South, manufacturing employment grew 27% in the core counties of the nine SMSAs, but grew 24% in the suburban counties of these SMSAs. This is due primarily to the core counties in Houston and Dallas which contain large suburban areas within them; without these two Texas SMSAs, manufacturing

employment in the suburbs of the South grew by 24%, about twice the rate (13%) of the core; this coincides with the pattern of growth in the other three regions.

These regional variations in growth are indicative of the trend since the turn of the century. The Northeastern SMSAs have continued to experience a decline in their share of the national total, while the other regions have experienced gains. In this study the largest gain in share occurred in the South (increasing in share of total employment from 15.3 to 16.5% and in manufacturing employment from 10.9 to 11.9%), while the West and North Central regions gained about half a percentage point. This may indicate the relatively greater attraction of industry to the SMSAs of the newly developing regional markets.

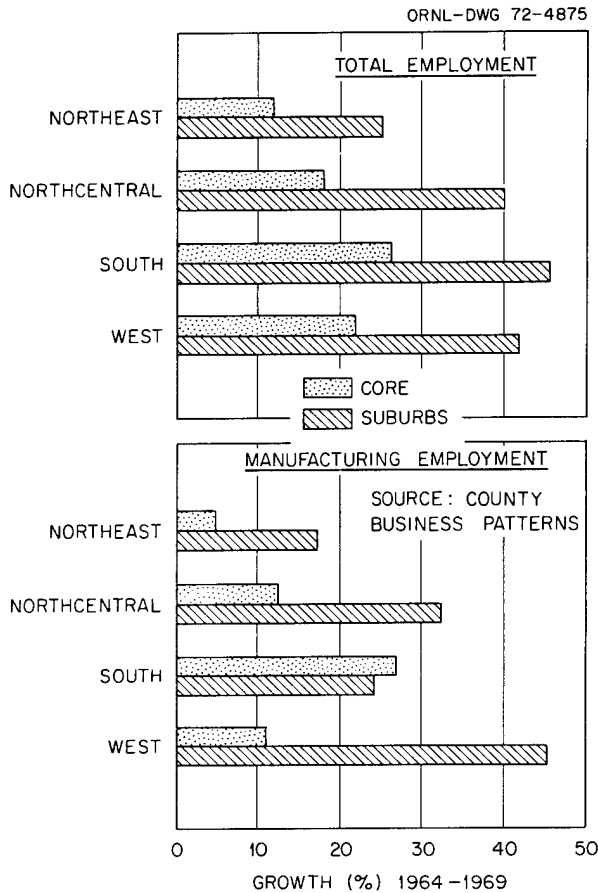

Fig. 7.4. Growth rates of employment in 33 SMSAs, 1964-1969.

In summary, the County Business Patterns data show that substantial growth in employment (21% in five years) has occurred in the 33 SMSAs examined. The growth in the suburban ring has occurred at a rate about twice as great as that in the core even though the overall absolute growth in the core has been numerically greater than that in the suburbs. The faster rate of growth in the suburbs may be taken as an indicator of the increasing attractiveness of the suburbs relative to the core in general, as the population as well as businesses locate increasingly in the suburbs. Thus, the trend of greater dispersion within SMSAs appears to be continuing.

The national trend toward regional dispersion also appears to have continued from 1964 to 1969. Employment in the SMSAs of the Northeast grew at a slower rate than in the other three regions; this region experienced a decline in the share of the national totals of both total employment and manufacturing employment located there. The largest gain in share occurred in the SMSAs of the South. The SMSAs of the West and

North Central also experienced an increase in their shares of the national totals, small though they were.

#### 7.4 CONCLUSIONS

The relationship between the dispersion of employment and population is believed to be a primary factor in the growth patterns of metropolitan areas. To date very little research has been done in this area. As a forerunner to an examination of this relationship, this study has attempted to determine the pattern of decentralization of employment.

Since the turn of the century, employment has been concentrating less in the metropolitan core and less in the Old Manufacturing Belt of the Northeast and Great Lakes. This dispersal of employment from the core to the suburbs and from the Northeast to other regions of the country has been found in several studies of changes in employment to 1964. Two of these studies, which also examined regional changes, found employment to have become more dispersed throughout the nation as well.

The 33 SMSAs examined in this study exhibited similar dispersion characteristics; the core and the Northeast experienced the slowest rates of growth and hence experienced declines in the shares of employment located there, even though both experienced absolute gains in employment between 1964 and 1969. Except in the case of manufacturing employment in the South, suburban employment in every region grew from two to four times faster than core employment. As with population, business seems to be locating with increasing frequency in the suburbs.

It would seem likely that the trends toward dispersal within a metropolitan area and among regions of the country which have been found in this and previous studies will continue in the near future. Since these patterns may be expected to have a significant influence on the location of population and housing, it is essential that we be aware of the trends and the relationship of employment and population. This study has provided an awareness of the former; future studies will attempt to analyze the latter.

#### REFERENCES

1. Daniel Creamer, *Manufacturing Employment by Type of Location: An Examination of Recent Trends* (Studies in Business Economics No. 106), New York, The National Industrial Conference Board, 1969.
2. ACIR, *State-Local Taxation and Industrial Location*, Washington, ACIR, April 1967.

3. Edwin S. Mills, "Urban Density Functions," *Urban Studies*, VII(1), February 1970.

4. John Kain, "The Distribution and Movement of Jobs and Industry," *The Metropolitan Enigma*, Washington, U.S. Chamber of Commerce, 1967.

5. Edgar M. Hoover and Raymond Vernon, *Anatomy of a Metropolis*, Harvard University Press, Cambridge, Mass., 1959.

## 8. Blacks and Suburbanization in Atlanta

William W. Pendleton    Martin L. Levin

### 8.1 INTRODUCTION

Funk and Wagnall's says that a suburb is a place adjacent to a city. The simplicity of that definition is appealing though it belies the complexity and importance of the pattern of settlement which adjoins a city. The social and cultural aspects of suburbs and the suburban way of life have come to dominate American social thought to the point that a home in the suburbs is often considered indicative of having arrived, of having joined the mainstream of American life.

The importance of suburban residence as an indication of individual social mobility led some investigators examining the 1970 Census of Population to view the increase in the black population residing in areas adjacent to cities as an indication of racial progress, a sign that things are getting better for blacks in America. Before evaluating the empirical basis for such an interpretation, the definition of suburb in this context must be established. The Standard Metropolitan Statistical Areas (SMSAs) of the nation are divided into a central city (or cities) and a remainder of residue sometimes called the ring of the SMSA. The ring is adjacent to the central city so it can be called the suburban part of the metropolitan area. The ring of course is not homogeneous, so it represents suburban life only crudely.

In the rings of several large SMSAs the proportion black increased between 1960 and 1970. Moreover, the proportion of all blacks in the SMSA living in the ring also increased. The magnitude of this black suburbanization was fairly small in most instances. The proportion of all blacks living inside metropolitan areas but outside their central cities increased from 15.1 to 16.2% between 1960 and 1970. That figure varied by region. In the Northeast it was the same at both points in time, 18.7%. In the North Central region the comparable figures were 11.6 to 12.8%, in the South 14.2 to 14.8%, and in the West 25.6 to 29.5%.

Blacks as a proportion of suburban population also showed some regional variation. Nationally, blacks maintained the same proportion in the suburbs, 4.8% in

1960 and 1970. Regionally, they increased their share of suburban population everywhere except the South, where the proportion black in the suburbs declined from 12.6 to 10.3%.

### 8.2 SUBURBANIZATION IN ATLANTA

The purpose of this study is to examine some of the consequences for blacks of suburban residence in a southern city, Atlanta, and determine how blacks fare with respect to their proportion of the population of the neighborhood. Overall, Atlanta followed the pattern of the South. Blacks became a smaller proportion of the total SMSA (declining from 22.8 to 22.3% of the total) even though their numbers increased by 34.2%. In the central city blacks increased by 36.8% and whites decreased by 20.0%, causing the proportion black to increase from 38.3 to 51.3%. In the suburbs blacks increased by 23.6% while whites increased by 72.5%, causing the proportion black to decline from 8.5 to 6.2%. Hence, in terms of absolute numbers, Atlanta offers no evidence of increasing black suburbanization. In fact, the contrary is the case. The proportion of blacks in the suburban population declined during the decade.

The small growth of the population in the central city of Atlanta can be partitioned into two parts: A natural increase of 12.2% and an out-migration of 10.2%. For the suburbs the figures are 21.5% due to natural increase and 47.2% due to in-migration. Atlanta experienced a net natural increase in the population of both races in the central city, though the black rate was more than twice that of the whites, 19.7 vs 7.4%. At the same time, black migration was only slightly less than black fertility in the central city, 17.5%, so the fairly large rate of out-migration by whites, 27.4%, can be viewed as the major reason the population of the city changed so little. The total increase of 9518 was partly due to annexation that added 3431 to the population.

In the ring, whites and blacks both had fairly high natural increase, and the rates were nearly equal, 21.4% for whites and 22.4% for blacks. In-migration, however,

was much higher for whites than for blacks; 49.6 and 11.4% are the respective figures. These data are indicative of a trend in which natural increase plays an increasingly important role in the ability of central cities to maintain their populations.

While the process of black suburbanization may not be a dominant theme in Atlanta, the 55,616 blacks residing in the suburbs of the city in 1970 do represent an increase of over 10,000 blacks when compared with the figure for 1960. We might ask if and why these blacks differ from blacks in the central cities. Specifically, we might ask if they differ in the same way whites residing in the suburbs differ from whites residing in the central city. Though the pattern is not simple, there emerges what might be called a suburban factor.\* The youth-dependency index is higher for blacks in the suburbs than for blacks in the central city; the same is true for whites. The age dependency for blacks in the suburbs is lower than for blacks in the central city; the same is true for whites. The fertility for blacks in the suburbs is higher than that of blacks in the central city; the same is true for whites. Fewer black households in the suburbs are female headed; the same is true for whites. The average value of black-owned homes in the suburbs is lower than that of black-owned homes in the central city; the same is true for white-owned homes. Housing for blacks is more crowded in the suburbs; the same is true for whites. Blacks in the suburbs, however, pay less rent than in the central city while whites in the suburbs pay more than whites in the central city. Thus, suburban residence in general seems to influence blacks in the same direction as it does whites.

Black-white differentials remain in both areas. Compared with whites, black youth dependency is higher everywhere though their age dependency is higher in the suburbs but lower in the central city. The fertility of blacks is higher in both places; the proportion of female-headed households is three times that of whites in the suburbs and over twice that of whites in the central city. The value of black-owned homes is half that of white-owned homes in the ring and two-thirds that of white-owned homes in the central city. Their rent is less than half that of whites in the ring and nearly half that of whites in the central city. Blacks are at least ten times as likely to be crowded as whites in the ring and six times as likely in the central city.

\*Tables showing these data are in another section of this report: "An Examination of Black Suburban Residence." Strictly speaking, all racial classification from this point on is based on blacks vs nonblacks. When white is used, it should be regarded as nonblack.

Moreover, there is no pattern of convergence between races in the suburb as compared with the central city. On five of the indices blacks are closer to whites in the suburbs (youth dependency, value of owned homes, contract rent, crowding in owned housing, and crowding in rented housing). On the other three indices they are more alike in the central city.

### 8.3 THE INFLUENCE OF THE PROPORTION BLACK

Suburbanization of blacks does not seem to have characterized the city of Atlanta. Though a suburban factor does seem to operate on the population of the city, residence in the suburb confers no undisputed advantage to the members of either race.† An additional analysis is suggested. If the black in white suburbia is better housed and more like his white neighbor demographically and socially, then those blacks living in predominantly white neighborhoods should differ from other blacks. A preliminary analysis of the relation between the proportion of the population black and selected indices shows that some such differences exist.

For this analysis those block groups and enumeration districts that had no blacks or no whites were excluded (in the ring, 300,597 whites lived in such areal units where there were no blacks, and 60 blacks lived in units where there were no whites. In the central city 33,231 whites lived where there were no blacks and 10,039 blacks lived where there were no whites). The remainder of the enumeration districts-block groups were classified as having 1 to 5% black; more than 5 to 40% black; more than 40 to 60% black; more than 60 to 95% black; and more than 95 to 99% black.

Tau, a rank correlation measure, was used to reflect how the proportion black in the areas was related to the indices mentioned earlier. The results are shown in Table 8.1. The pattern which emerged is not entirely unexpected but does show several anomalies. Youth dependency for blacks increases as the proportion black increases. In the central city, the same association is found for whites; that is, white youth dependency increases as the proportion black increases, but in the ring percent black and white youth dependency are unassociated. In both the central city and the ring, age dependency for whites increases as the proportion black increases, but the age dependency for blacks increases

†The aggregations used to define the suburb are examined for several cities elsewhere in this report: "An Examination of Black Suburban Residence." Atlanta does not show as clear a suburban factor as some of the other cities.

Table 8.1. Rank order correlation coefficients showing the association between percent black and selected demographic indices, Atlanta, 1970

Index	Rank order correlation coefficient			
	Central city		Ring	
	Black	Nonblack	Black	Nonblack
Youth dependency	0.8	0.8	0.8	0.0
Aged dependency	0.2	0.6	-0.6	1.0
Fertility ratio	0.4	0.6	0.6	0.8
Proportion of households headed by female	0.8	0.8	0.4	1.0
Value of owned dwelling units	-0.2	-0.8	-0.2	-1.0
Average rent	-0.6	-0.8	-0.2	-0.6
Crowding for blacks				
Owners	-1.0		-0.6	
Renters	-4		-0.8	

in the central city while declining in the ring, perhaps reflecting the presence of younger families in the predominantly black areas of the ring, a possible indication of new ghetto formation.

Fertility for both races is positively associated with percent black, and the strength of that association is

greater in the suburbs for both races. The proportion of households that are headed by females is also positively associated for both races in the central city and in the ring, but the association is stronger in the central city for blacks and in the ring for whites. In the central city and the ring the average value of owned housing is negatively associated with the percent black, and the association is stronger for whites than for blacks in both areas, as might be expected. Rent follows a pattern similar to that for value of owned housing. Perhaps the greatest surprise is that crowding for blacks is less as the proportion black increases.

The results of this analysis seem to indicate that black suburbanization, to the extent that it does exist, exists for relatively few blacks, and those blacks are those who reside in neighborhoods that are predominantly white. At the same time, the advantages to blacks of living among whites are not unequivocal. For example, household crowding for blacks increases as the proportion black in the areal unit decreases. Additional analysis controlling for socioeconomic status, length of residence, and average age of the population is obviously indicated before these findings can be taken as a determination of the nature of black suburbanization or the extent to which benefits accrue to blacks by residence in predominantly white areas.

## 9. An Examination of Black Suburban Residence

William W. Pendleton    Martin L. Levin

### 9.1 INTRODUCTION

One major trend observed in the 1970 Census of Population reports is the enormous growth of the population in Standard Metropolitan Statistical Areas (SMSAs) residing outside their central cities. In fact some central cities declined in population during the decade of the sixties.\* Others maintained their populations by a high rate of natural increase, a reversal of the traditional source of urban population growth.† In contrast to their central cities, the suburban parts of the SMSAs received large numbers of migrants. This process is shown in Table 9.1, where population change from 1960 to 1970 is shown for central cities and their rings.

These results become especially important when racial components are examined. While the population of SMSAs is suburbanizing at a very rapid rate and the black population of central cities is increasing, the movement of population to the suburbs is not restricted to whites. In the nation as a whole, the proportion of all blacks living in SMSAs but outside their central cities increased from 15.1 to 16.2% between 1960 and 1970. These figures varied regionally. In the Northeast it remained at 18.7% while changing in the North Central from 11.6 to 12.8%, in the South from 14.2 to 14.8%, and in the West from 25.6 to 29.5%. Blacks increased their share of the suburban population in all regions except the South, but the changes were small, and the decline in the South from 12.6 to 10.3% of the suburban population was sufficient to balance gains in other regions, leaving the national figure of 4.8% unchanged over the decade. The fact that blacks maintained that percentage is an indication that they participated to some degree in the suburbanization process. This paper seeks to examine that participation to deter-

\*Of the 243 central cities in the country, 95 lost population during the decade.

†The natural increase (births - deaths) is associated with the size of the cities with the smaller cities having a greater increase. This difference may be due to annexing high fertility areas.

Table 9.1. Population change in central cities and rings: 1960-1970

	Number of persons	Percent change
Central cities	3,194,453	5.3
Rings	16,598,213	28.2

mine what kind of suburbanization is involved and what, if any, advantages accrue to blacks by suburban residence in ten selected cities.

### 9.2 PATTERNS IN SUBURBAN RESIDENCE

The extensive variation shown in Table 9.2 is prima facie evidence that these cities have different kinds of populations in their rings, and suburbanization so defined might be expected to be different in each place.‡ Further evidence that these suburbs have different relations to their central cities is given by the proportions of the populations that reside in the central city. The variation in percent of population living in the central city ranges from 77.2 in Albuquerque to 26.4 in St. Louis. This variation is not simply a function of size but reflects the complicated political and social processes by which city and county boundaries have been fixed. The tenuous nature of the definition of suburb is further underscored by the varying, and in some cases quite large, proportions of the suburban populations that are classified by the Census Bureau as rural. Fully a quarter of the 72,023 people who make up the suburban population of Albuquerque are classed as rural. Hence, the nonrural suburban population of that city is only about 15% of the total. This rural suburban population is found in every city, but is only 3.6% of

‡The use of the "ring" or that part of the SMSA that lies outside the central city to mean suburb is fairly common. All the ring is, of course, not suburban in the ordinary sense of the word, but it is politically and geographically suburban, being independent of the government of the city and surrounding its land area (for the cities in this analysis, at least).

Table 9.2. Population of ten SMSAs by proportion of total living in the central city and proportion of ring classed as rural: 1970.  
Also, the components of growth for central city and ring shown by race: 1960-1970.

City	Population	Black (%)	Total in central city (%)	Ring classed as rural (%)	White		Nonwhites	
					Natural increase	Net migration	Natural increase	Net migration
Albuquerque								
Central city	243,751	2.2	77.2		22.6	-1.4	NA	NA
Ring	72,023	1.8		25.4	13.3	4.8	NA	NA
Atlanta								
Central city	496,793	51.3	35.7		7.4	-24.4	19.7	17.5
Ring	893,191	6.2		21.3	21.4	49.6	22.2	11.4
Cincinnati								
Central city	452,524	27.6	32.9		9.8	27.0	18.2	-2.3
Ring	932,327	2.9		23.4	12.4	9.0	7.3	34.5
Cleveland								
Central city	750,903	38.3	36.4		6.7	-33.1	16.8	-1.1
Ring	1,313,291	3.4		9.4	11.0	12.5	59.9	658.0
Detroit								
Central city	1,511,482	43.7	36.0		3.6	-32.7	18.0	20.0
Ring	2,684,093	3.6		6.9	16.9	11.4	19.2	14.8
New Orleans								
Central city	593,471	45.0	56.7		5.7	-23.3	19.4	-4.5
Ring	452,338	12.5		13.0	22.1	45.4	25.1	5.1
Philadelphia								
Central city	1,948,609	33.6	40.4		3.9	-16.8	17.8	7.4
Ring	2,869,305	6.6		18.1	11.4	10.2	18.6	19.3
St. Louis								
Central city	622,236	40.9	26.4		2.4	-34.0	19.5	-0.4
Ring	1,733,850	7.2		18.8	13.3	13.3	22.0	37.2
San Francisco								
Central city	1,077,235	20.0	34.6		0.5	-17.7	22.6	28.7
Ring	2,032,284	5.4		3.6	13.5	14.7	27.4	62.4
San Jose								
Central city	445,779	2.5	41.9		31.7	86.6	NA	NA
Ring	618,935	1.2		4.0	16.9	24.3	NA	NA

the suburban population of San Francisco, the lowest in this group. The SMSAs of New Orleans and San Jose have some rural population in their central cities, a phenomenon that emphasizes the varying nature of the suburban-nonsuburban distinction.

### 9.3 COMPARISONS OF BLACKS AND WHITES

In this context, blacks and whites can be compared in both the central cities and the suburbs. To the extent that blacks in the central city differ from blacks in the ring in the same way as whites in the central city differ from whites in the ring, a suburban factor can be inferred for both blacks and whites. If such differences

do not follow the same pattern, then black residence in the ring is not suburbanization in the way that white residence is, and black suburbanization probably reflects a different process such as an extension of black neighborhoods beyond a city's limits or a growth in traditionally black areas or communities in the ring.

An additional comparison is possible. If the differences between whites and blacks in the rings are less than those in the central cities, then some evidence exists to support the contention that suburbanization of blacks represents an improvement in the condition of blacks vis-a-vis whites. Such a finding might point toward urban residential patterns that would reduce black-white differentials and perhaps thereby reduce black-white tensions.

The variables available for this study were restricted by the nature of census reporting. At this time only some of the census data have been released. These data consist of the tabulations based on the questions asked of every household. These tabulations do not include information on education, occupation, or migration status of the family. This study employs the following variables:

1. Youth dependency — the ratio of children under 15 years of age to the population aged 15–64 multiplied by 100.
2. Aged dependency — the ratio of the population over 65 to those 15–64 multiplied by 100.
3. Total dependency — the sum of aged and youth dependency.
4. The child-woman ratio or the fertility ratio — the number of children less than 5 years of age per 1000 women aged 15–44.
5. The percent of the population who have never married.
6. The percent of households that have a female head.
7. The average value of owned housing units.
8. The average monthly rent of rented housing units.
9. The percentage of owned or rented units that have more than 1.01 persons in residence for each room.
10. The proportion of housing units that are single detached dwelling units.
11. The proportion of owned and rented units that lack one or more major plumbing features.\*

These variables are examined by sex and race as is appropriate in conjunction with the variables mentioned earlier: percent population that is black, size of city, and proportion of total population in central city.<sup>†</sup>

Certain aspects of the variation among these cities have been noted. Others should also be considered. Youth dependency and aged dependency vary with respect to race and SMSA, though they do not follow the same pattern (see Table 9.3). Total dependency, being a combination of aged and youth dependency,

reflects the greater youth dependency in all places and follows the same pattern. The fertility ratio also varies by race and place of residence, with black fertility being consistently higher and somewhat more variable than that of nonblacks (Table 9.3).

The percent of the population that has never married shows a fairly stable pattern throughout the population. Males of both races are more likely to be single than females, but blacks of both sexes are more likely to have never married than whites. The ranges in these proportions are not great from city to city (Table 9.4). The racial and sexual differences, however, indicate important differences in family style or life cycle, or both, among those groupings.

A large proportion of households headed by females has been frequently identified as characteristic of the black population. These data support that finding, with rates for blacks being from two to nearly four times that of whites in almost every location. The rate for blacks, however, is variable, ranging from a low of 8.0 in the ring of Albuquerque to a high of 32.6 in the central city of Philadelphia (Table 9.4).

The value of owned housing varies from city to city even more than it does from race to race within cities. San Jose, in the ring for both races and in the central city for blacks, has the highest values, while San Francisco has the highest value for nonblacks in the central city. Lowest values for houses owned by both races are found in the ring of Albuquerque. The highest average monthly contract rent is found in San Jose for both races and for central city and ring. Low values for blacks are found in southern cities, Atlanta and New Orleans (Table 9.5).

That high rents are not always associated with favorable conditions is illustrated by the data on crowding (Table 9.6). San Jose, with the highest values in three of four groupings in Table 9.5, has the highest percentage of black-owned, crowded housing in its central city. Moreover, the high rent in that central city for whites is associated with the highest rate of crowding for that group in any central city. Though renters are generally more crowded than owners, blacks, regardless of tenure, are two to three times as likely as whites to be crowded except among renters in the ring of Albuquerque.

Though apartment complexes have been built on main commuter highways at the edge of the city, most Americans associated the idea of suburban living with owning a separate house. Though data are not available by race, the proportion of all housing units that are single detached units was calculated for the central cities and rings of the selected SMSAs (Table 9.6).

\*More precise definitions of the census concepts can be found in the *1970 Census Users' Guide*.<sup>1</sup> For definitions of the ratios and indices employed in this report see *Demographic Profiles of the United States*.<sup>2</sup>

<sup>†</sup>Strictly speaking, all racial classification from this point on is based on blacks vs nonblacks. When white is used, it should be regarded as nonblack.

Table 9.3. Youth dependency, aged dependency, and fertility ratios by race for the central cities and rings of ten selected SMSAs: 1970

City	Youth dependency		Aged dependency		Fertility ratios	
	Blacks	Nonblacks	Blacks	Nonblacks	Blacks	Nonblacks
Albuquerque						
Central city	68.0	48.2	7.0	10.3	458	373
Ring	70.3	63.6	5.0	8.8	600	482
Atlanta						
Central city	55.0	30.0	10.1	18.0	429	311
Ring	64.9	47.8	9.3	7.8	508	390
Cincinnati						
Central city	58.4	37.1	13.8	24.0	463	382
Ring	59.0	53.0	14.0	13.4	492	436
Cleveland						
Central city	56.0	40.1	10.9	21.1	417	439
Ring	54.1	44.9	5.4	13.6	390	387
Detroit						
Central city	55.7	35.4	9.8	25.3	481	392
Ring	59.5	51.7	9.0	10.1	469	421
New Orleans						
Central city	63.7	33.5	12.7	20.8	495	319
Ring	74.7	52.8	9.7	8.4	581	434
Philadelphia						
Central city	55.2	35.6	11.6	22.3	442	373
Ring	57.0	46.3	10.8	13.7	466	397
St. Louis						
Central city	61.4	34.0	14.4	31.7	476	353
Ring	70.5	48.8	11.9	13.4	545	394
San Francisco						
Central city	52.1	24.9	8.1	23.6	428	266
Ring	55.0	42.3	6.9	11.5	439	355
San Jose						
Central city	69.2	54.4	4.1	9.2	508	442
Ring	57.0	47.8	4.1	9.9	467	361

Albuquerque has very high rates in both central city and ring. San Jose has nearly the same proportion in both central city and ring. In their central cities St. Louis, Cincinnati, Cleveland, and San Francisco have only slightly over one-third of their housing classed as single detached dwelling units. This suggests that even fairly standard characteristics of suburban life vary considerably from city to city.

Examining the proportion of housing units without some major plumbing facility reveals fairly low rates in almost every case. The major exceptions are the ring of Albuquerque and the blacks in southern cities. Generally, if there is a difference, blacks have a higher figure than whites, renters higher than owners, and ring dwellers higher than those living in the central city.

#### 9.4 THE SUBURBAN FACTOR

If the residents of the rings and of the central cities differ from each other in some consistent pattern, the hypothesis that a suburban factor operates on both whites and blacks is supported. If the pattern applies to blacks as well as whites, then the suburban factor acts on both races, and the idea of black suburbanization can be entertained. If, in operating on both races, this factor renders the races more alike demographically and socially, then the hypothesis that suburbanization of blacks contains some germ of racial progress is supported.

In Table 9.7, selected indications of a suburban factor are given for the cities in this study. As can be seen, in

Table 9.4. Percent of the population over 14 years of age and never married by sex and race and percent of households headed by females by race in the central cities and rings of ten selected SMSAs: 1970

City	Over 14 never married (%)				Female-headed households (%)	
	Blacks		Nonblacks		Blacks	Nonblacks
	Males	Females	Males	Females		
Albuquerque						
Central city	33	34	29	24	31.0	12.1
Ring	34	23	30	23	8.0	10.5
Atlanta						
Central city	34	28	30	22	30.5	13.5
Ring	36	28	23	19	24.8	7.0
Cincinnati						
Central city	32	27	30	26	31.2	13.7
Ring	33	25	25	22	19.2	7.7
Cleveland						
Central city	32	27	29	23	29.7	13.4
Ring	29	26	26	23	17.7	7.2
Detroit						
Central city	32	26	29	22	26.0	12.7
Ring	36	29	26	22	24.6	6.9
New Orleans						
Central city	35	28	31	25	32.1	14.3
Ring	35	28	24	20	22.2	7.0
Philadelphia						
Central city	34	28	31	25	32.6	13.0
Ring	38	30	28	23	25.8	8.0
St. Louis						
Central city	34	27	28	24	32.3	15.0
Ring	33	27	25	21	27.4	7.0
San Francisco						
Central city	35	26	35	27	29.6	13.8
Ring	35	26	28	21	25.9	8.8
San Jose						
Central city	34	29	27	22	18.5	9.4
Ring	35	25	30	23	15.4	9.0

almost every city the youth dependency ratio shows a consistent suburban factor, with less youth dependency in the central city and more in the suburbs. San Jose and Cleveland offer the only exceptions.

The case of aged dependency is equally clear. Younger families in the suburbs and older families and individuals in the central city should give rise to lower aged dependency in the suburbs. That is true in every case for both races, except for small exceptions in Cincinnati for blacks and in San Jose for whites.

If suburban families are younger, they should be expected to have more young children and hence a higher fertility ratio. At the same time, if the idea of

young blacks crowding the central city and giving birth to large numbers of children has any validity, then the suburban factor should produce high rates of fertility for whites in the ring while restricting the difference, perhaps reversing it, for blacks. In general, such a pattern does not emerge from these data. Though black fertility is higher in the central cities of Cleveland and San Jose, so is white fertility. Only in Detroit is black fertility higher in the central city while white fertility is higher in the ring. Though the fertility pattern is not without some exceptions, the influence of suburban residence on fertility seems to occur in both areas.

Table 9.5. Monthly contract rent for rented dwelling units and average value of owned homes by race of occupants in the central cities and rings of ten selected SMSAs: 1970

City	Monthly contract rent		Average value of owned homes	
	Blacks	Nonblacks	Blacks	Nonblacks
Albuquerque				
Central city	\$ 66	\$102	\$12,173	\$18,632
Ring	92	72	8,601	15,498
Atlanta				
Central city	68	115	16,273	24,902
Ring	63	133	13,056	24,162
Cincinnati				
Central city	67	98	15,210	19,369
Ring	64	91	15,118	20,758
Cleveland				
Central city	77	88	16,404	17,686
Ring	99	140	20,720	28,078
Detroit				
Central city	78	99	14,828	16,641
Ring	80	142	15,636	25,302
New Orleans				
Central city	59	93	17,273	27,420
Ring	52	113	12,985	22,678
Philadelphia				
Central city	70	105	9,102	18,838
Ring	81	123	12,393	21,709
St. Louis				
Central city	64	83	11,666	14,870
Ring	66	114	11,548	19,824
San Francisco				
Central city	103	134	21,774	29,352
Ring	106	149	20,768	30,765
San Jose				
Central city	129	139	23,075	27,791
Ring	148	156	25,848	32,092

Table 9.6. Percentage of dwelling units that have more than 1.01 persons per room by race and tenure and percentage of all dwelling units that are single detached in the central city and ring of ten selected SMSAs: 1970

City	More than 1.01 persons per room				Single detached dwelling units (%)
	Blacks		Nonblacks		
	Owned	Rental	Owned	Rental	
Albuquerque					
Central city	18.1	21.8	7.7	9.1	76
Ring	34.8	14.3	19.7	23.4	85
Atlanta					
Central city	14.4	22.8	2.5	6.3	49
Ring	23.4	29.6	3.5	7.1	73
Cincinnati					
Central city	12.8	17.4	6.2	8.5	35
Ring	13.1	18.8	8.1	11.5	77
Cleveland					
Central city	9.3	11.2	5.3	6.2	38
Ring	7.4	5.2	4.6	3.4	72
Detroit					
Central city	11.8	10.7	5.5	5.1	54
Ring	16.9	16.8	8.4	5.7	81
New Orleans					
Central city	18.8	30.3	4.2	8.4	45
Ring	27.7	40.8	8.8	11.8	78
Philadelphia					
Central city	7.1	13.9	4.1	5.4	66
Ring	10.5	17.3	4.2	5.0	77
St. Louis					
Central city	8.0	23.4	7.2	9.3	34
Ring	18.8	24.9	8.3	8.1	80
San Francisco					
Central city	13.6	15.2	4.6	6.7	38
Ring	15.1	16.4	4.2	6.2	72
San Jose					
Central city	20.4	24.3	6.2	9.9	70
Ring	17.5	9.1	5.1	7.3	68

Though black communities and neighborhoods have proportionately more female-headed households, suburban residence produces fewer such households in both races. In most cases, the blacks' proportion of female-headed households is less different between the two areas, Albuquerque being the single exception, but even there a suburban factor influences both races in the same direction.

Value of owned homes and average monthly rent show less consistent patterns. In six of the ten SMSAs, the average value of black-owned housing was greater in the central city than in the ring. In all but three of the SMSAs the value for white housing was greater in the ring. Rents are generally higher for both races in the

city. However, in three SMSAs, blacks pay higher rent in the central city and whites pay more in two. Wherever whites owned more valuable homes in the central city than in the ring, blacks did also. That was not the case for rent, but the exceptions are few. Probably the central city vs ring definition of suburb is not socioeconomically restrictive — there are poor suburbs and wealthy central city areas which offset each other in some places differently.

Except for residents of Cleveland, San Jose, and white residents of San Francisco, those in the central cities who own their homes are less crowded than those in the ring. This result shows that the worst conditions of

Table 9.7. Comparison of indices<sup>a</sup>

City	Youth dependency	Aged dependency	Fertility ratio	Female heads of house	Value owned units	Rent rented units	Crowding in owned units	Crowding in rented units
Albuquerque								
Blacks	-	+	-	+	+	-	-	+
Nonblacks	-	+	-	+	+	+	-	-
Atlanta								
Blacks	-	+	-	+	+	+	-	-
Nonblacks	-	+	-	+	+	-	-	-
Cincinnati								
Blacks	-	-	-	+	+	+	-	-
Nonblacks	-	+	-	+	-	+	-	-
Cleveland								
Blacks	0	+	+	+	-	-	+	+
Nonblacks	-	+	+	+	-	-	+	+
Detroit								
Blacks	-	+	+	+	-	-	-	-
Nonblacks	-	+	-	+	-	-	-	-
New Orleans								
Blacks	-	+	-	+	+	+	-	-
Nonblacks	-	+	-	+	+	-	-	-
Philadelphia								
Blacks	-	+	-	+	-	-	-	-
Nonblacks	-	+	-	+	-	-	-	+
St. Louis								
Blacks	-	+	-	+	+	-	-	-
Nonblacks	-	+	-	+	-	-	-	+
San Francisco								
Blacks	-	+	-	+	+	-	-	-
Nonblacks	-	+	-	+	-	-	+	+
San Jose								
Blacks	+	0	+	+	-	-	+	+
Nonblacks	+	-	+	+	-	-	+	+

<sup>a</sup>Table entries indicate the direction of difference between the central city and ring.

crowding of blacks found in some parts of large cities do not extend to the entire black population. Even though blacks are more likely to be crowded than whites in either the central city or ring, they, like the whites, are more likely to live in crowded units in the ring. The pattern for renters has more exceptions than that for owners, but is not entirely different. Again, Cleveland and San Jose reverse the differences for both races, but Philadelphia and St. Louis join San Francisco in having more crowding among black renters in their central cities. With the exception of St. Louis, these five cities have comparatively low crowding rates. An interesting question with respect to relative and absolute deprivation could be posed in terms of the suburban-urban movement of blacks in these different cities.

Though the suburban factor seems real, another question remains: Is there any reduction in black-white differences brought about by residence in the ring? Table 9.8 shows the 80 comparisons that were made to answer that question. Of those comparisons, 41 show greater similarity between the races in the suburbs. Thus, slightly over half of the measures show racial convergence. The measures showing convergence are concentrated among demographic rather than social characteristics. Youth dependency shows convergence in every city, aged dependency in seven, and the child-woman ratio in seven. The value of owned homes shows convergence in no case and rent in only four. The conclusion must be that the suburban factor operates on both races, but it is mostly a demographic phenomenon reflecting stages in the life cycle rather than

Table 9.8. Influence of suburban residence on reducing the differences between blacks and whites in ten selected SMSAs: 1970

City	Youth dependency	Aged dependency	Fertility ratio	Female heads of house	Value owned units	Rent rented units	Crowding in owned units	Crowding in rented units
Albuquerque	S <sup>a</sup>	—	—	S	—	S	S	S
Atlanta	S	S	S	—	—	—	—	—
Cincinnati	S	S	S	—	—	S	S	S
Cleveland	S	—	S	—	—	S	S	S
Detroit	S	S	S	—	—	—	S	—
New Orleans	S	S	S	—	—	—	S	S
Philadelphia	S	S	S	—	—	—	—	—
St. Louis	S	S	—	—	—	—	S	—
San Francisco	S	S	S	—	—	—	—	—
San Jose	S	—	—	S	—	S	—	S

<sup>a</sup>S indicates that blacks and whites are more alike in the ring than in the central city on the index in question; — indicates the reverse.

socioeconomic condition. In the aggregate, suburban residence, at least in these cities, confers neither economic betterment nor less-crowded housing to blacks. Suburban blacks are *demographically* more like suburban whites than central city blacks are like central city whites. *Economically*, at least in respect to the data available, suburban blacks are less like their suburban white neighbors than blacks in the central city are like their white neighbors.

### 9.5 CONCLUSIONS

Although this analysis is preliminary and additional census material will provide better answers to many of the questions raised, certain conclusions can be entertained. The "ring," though a political suburb, does not conform to the social and economic pattern generally associated with suburbs. Although subsections of the ring may be suburban in every sense, the cities

examined in this study are not surrounded by an area of uniformly better housing and less-crowded conditions. The cities are different; their suburbs are different. Moreover, the variable nature of the suburbs themselves indicate that they should not be treated as a unit. Definitions other than the political one employed here should be examined as new data become available. One definition, the fringe of the urbanized area, is examined in another part of this report, "The Growth of Urbanized Areas."

### REFERENCES

1. U.S. Bureau of the Census, *1970 Census Users' Guide*, U.S. Government Printing Office, Washington, D.C., October 1970.
2. E. S. Lee, *Demographic Profiles of the United States*, ORNL-HUD-24, 1971, pp. 2-6.

# 10. The Fertility of Negroes without Southern Rural Experience: A Reexamination of the 1960 GAF Study Findings with 1967 SEO Data

P. Neal Ritchey\*

## 10.1 INTRODUCTION

The voluminous migration of blacks from rural areas to large metropolitan centers is a well-documented fact. The extent to which the fertility of migrants disproportionately contributes to the population pressures in urban ghettos, however, is subject to question. Are higher birth rates carried from rural to urban areas? How does the fertility of indigenous urban blacks compare with that of their white counterparts?

Three studies have attempted to assess the fertility of black migrants. However, only one study provided post-World War II data (i.e., when the urban racial differential changed markedly) as well as comparisons of blacks with whites – the 1960 *Growth of American Families Study* (GAF).

A major finding obtained in the 1960 GAF study was that the white-black differential in fertility was attributable to blacks with current or previous rural experience in the South.<sup>1</sup> The authors separated whites and blacks into those with current or previous southern rural experience and those with no southern rural experience. Highest fertility, as expected, was found among blacks in the rural South. Blacks without southern rural experience had lowest fertility, and those with previous but not current southern rural residence had fertility intermediate to the two comparative black groups. The important discovery, however, was that whites and blacks with no southern rural experience had approximately the same average family size. That is, "...by the time nonwhite couples are one generation or more removed from the rural South, their fertility is very much like that of the white population."<sup>2</sup> It was concluded that as rural experience becomes less common among blacks, the racial differential in fertility will disappear.

---

\*Work supported in part by the Department of Sociology, University of Georgia.

Other students of fertility see even greater importance in this finding. Hill and Jaffe state:

"This finding...is especially significant in light of the fact that Negroes who are one generation or more removed from the rural South are still subject to continuing discrimination in employment, income, housing, education, and health services which does not affect their white counterparts..."<sup>3</sup>

Its implications are that blacks of urban origin are currently reproducing at a lower level than whites similarly placed on the socioeconomic scale. It may then be inferred that as social and economic inequalities between whites and blacks decline, black fertility will fall below the white level.

On the basis of the GAF study findings, one would expect considerably lessened population increase among blacks. If, indeed, black indigenous urbanites are reproducing at levels below that of whites similarly placed socioeconomically, an impact on the current standard of living of these blacks is to be expected. The youth dependency burden would be ameliorating and, relative to white counterparts, greater expenditures for current needs and for the training and education of children would be realized.

However, before the GAF findings are accepted, two considerations are worthy of attention: (1) The GAF study findings are based on the fertility experience of only 270 black couples and (2) the classification of residence background employed in the GAF study removed the effects of rural origin and current rural residence for the black population, but retained them in the counterpart white population. Almost all blacks with rural experience may have had that experience in the South. Among whites, a minority of persons with rural experience had that experience in the South. Thus, the comparison between black and white fertility within the category of "no southern rural experience" was between blacks of urban background and whites of rural and of urban background. In this paper, these

findings are reexamined with a larger sample and the effects of rural experience removed for both black and white segments.

## 10.2 DATA SOURCE

These findings are an extension on the author's doctoral dissertation, *Migration and Fertility: A Study of the Social Factors Involved*.<sup>4</sup> The data source for this analysis was the 1967 Survey of Economic Opportunity (SEO), a national sample. The residence background of both husband and wife were utilized to determine the couple's residence background. For the sample design, definitions, limitations, and procedure of analysis, the reader is referred to the dissertation.

## 10.3 FINDINGS

The 1960 GAF study used three categories of residence background: (1) no southern rural experience; (2) previous, but not current, southern rural residence; and (3) current southern rural residence. The 1967 SEO analysis offers, in addition to a substantially larger sample of black couples, a more refined residence background classification for white-black comparisons.

Only 6% of the black couples in the SEO sample migrated from a nonsouthern rural area to an urban area (2%) or were residing in a nonsouthern rural area in 1967 (4%), as shown in Table 10.1. In the GAF study, these two populations were combined with the urban couples of urban origin, yielding the "no southern rural experience" population. For blacks, the classification "no southern rural experience" contained relatively few couples with rural experience.

Among whites, however, this was not the case. The "no southern rural experience" classification included a substantial number of white couples with rural experience, which seriously contaminated the measure of urban background. Approximately 31% of white SEO couples had rural experience outside the South. The nonsouthern rural population, 20% of all white couples, had the highest fertility among whites, 2839 children per 1000 married-once women (Table 10.2). The white urban migrants of nonsouthern rural origin, 11% of all white couples, had the highest fertility among white urbanites (2580). In the GAF study the result of combining these two groups with rural experience and urban whites of urban background was to inflate, and thus to bias, the rate for the category "no southern rural experience." Therefore, comparing blacks and whites with no southern rural experience resulted in the comparison of a population in which rural experience

**Table 10.1. Number and percent distribution of couples with wives, age 20-44, by southern-nonsouthern rural experience and marital status and race, 1967<sup>a</sup>**

Southern-nonsouthern rural experience	Numbers in thousands			
	White		Negro	
	No.	%	No.	%
<b>Ever married</b>				
Total couples	19,810	100.0	1,849	100.0
Southern rural-to-urban migrants <sup>b</sup>	1,585	8.0	446	24.1
Nonsouthern rural-to-urban migrants <sup>c</sup>	2,297	11.6	37	2.0
Urban-of-urban origin	9,398	47.4	975	52.7
Southern rural population	2,498	12.6	324	17.5
Nonsouthern rural population	4,032	20.4	68	3.7
<b>Married once</b>				
Total couples	17,488	100.0	1,560	100.0
Southern rural-to-urban migrants <sup>b</sup>	1,362	7.8	365	23.4
Nonsouthern rural-to-urban migrants <sup>c</sup>	2,000	11.4	33	2.1
Urban-of-urban origin	8,361	47.8	816	52.3
Southern rural population	2,214	12.7	282	18.1
Nonsouthern rural population	3,553	20.3	65	4.1

<sup>a</sup>Numbers are independently rounded; therefore, column sums may not equal total.

<sup>b</sup>Couples in which either husband or wife or both are of southern rural background.

<sup>c</sup>Couples in which either husband or wife or both are of rural background, neither being of southern rural background.

Source: 1967 Survey of Economic Opportunity.

was minimal to another population containing a substantial proportion of couples with rural experience.

The residence background classification used in this study allowed comparison of "purely" urban blacks and whites. As very small proportions of blacks were classified as nonsouthern rural-to-urban migrants and nonsouthern rural population, these two classes were excluded from the analysis which compared white and black fertility rates. The following discussion cites rates of childbearing among couples in which the wives had married only once. Nevertheless, the relationships were valid within both ever-married and married-once groupings.

For indigenous urban couples, fertility was 25% higher among blacks than whites (Table 10.2): Blacks in the SEO sample had 3131 children per 1000 women compared with 2496 among whites. In fact, regardless of their residence background, fertility among these

Table 10.2. Age-standardized rates of children ever born per 1000 wives, age 20–44, by southern-nonsouthern rural experience and marital status and race, 1967<sup>a</sup>

Southern-nonsouthern rural experience	Children ever born		Ratio of black to white (%)
	White	Negro	
	Ever married		
Total couples	2587	3397	131
Southern rural-to-urban migrants <sup>a</sup>	2472	3171	128
Nonsouthern rural-to-urban migrants <sup>b</sup>	2528	2608*	*
Urban-of-urban origin	2492	3112	125
Southern rural population	2708	4502	166
Nonsouthern rural population	2813	3949	140
	Married once		
Total couples	2589	3462	134
Southern rural-to-urban migrants <sup>a</sup>	2444	3260	133
Nonsouthern rural-to-urban migrants <sup>b</sup>	2580	2684*	*
Urban-of-urban origin	2496	3131	125
Southern rural population	2649	4518	171
Nonsouthern rural population	2839	4084	144

\*Bases too small for estimate to be considered valid.

<sup>a</sup>Couples in which either husband or wife or both are of southern rural background.

<sup>b</sup>Couples in which either husband or wife or both are of rural background, neither being of southern rural background.

Source: 1967 Survey of Economic Opportunity.

blacks was higher than that among any of the white couples. These results strongly contradict those of the GAF study.

Both of the remaining groups of blacks — southern rural blacks and urban black couples of southern rural background — had borne more children than indigenous urban blacks, 4518 and 3260 as against 3131. However, fertility was still remarkably lower among migrants from the rural South to urban areas than among the sending population. Migration from the rural South to urban areas has drastically reduced the fertility of blacks (average fertility has dropped more than one child per woman).

The greatest excess of black fertility over that of whites occurred in the rural South. In this region, black fertility was 71% greater than that among white couples. For urban couples of southern background, black fertility exceeded white by 33%.

Among whites, the most striking finding was the lower rate of reproduction found among southern rural

couples in contrast to that among nonsouthern rural couples.

#### 10.4 CONCLUSIONS

Indigenous urban blacks had 25% higher fertility than indigenous urban whites, a finding contrary to that implied by the GAF study. Both the sample size and the residence background categories used in the GAF study contributed to the overestimation of the effects of southern rural background on the racial differential in fertility.

The SEO data indicated that the fertility of black migrants out of the rural South was sharply curtailed in contrast to those remaining in the rural South. Although urban blacks of southern rural background had nominally higher fertility than indigenous urban blacks, the difference was not substantively significant. Both the fertility of in-migrants and of indigenous urban blacks contributed to population pressures in urban areas. Proportionally, their contributions were about equal. However, indigenous urban blacks outnumbered black migrants two to one, and in absolute numbers, their share of births was disproportionate in the same ratio. The data suggest that a high youth dependency burden, with its resultant limitations on social and economic mobility, is characteristic of all urban black couples and not simply an attribute of in-migrants from the rural South.

The greatest excess of black over white fertility occurred in the rural South where, consistent with recent trends, it appeared that white fertility continued to decline precipitously. In all likelihood, this increasing gap marks a greater social and economic differential between blacks and whites in this area which will continue to widen.

As the influence of southern rural patterns of mating and child bearing diminishes, the white-black fertility differential will decline, as was suggested by the authors of the GAF study. However, it is evident that other factors, in addition to those associated with rural background, must be sufficiently altered before the white-black differential in fertility ceases to exist.

#### REFERENCES

1. P. K. Whelpton, A. A. Campbell, and J. E. Patterson, *Fertility and Family Planning in the United States*, Princeton University Press, 1966.
2. A. A. Campbell, "Fertility and Family Planning among Nonwhite Married Couples in the United States," *Eugenics Quarterly* 12, 124–31 (1965).

3. A. C. Hill and F. S. Jaffe, "Negro Fertility and Family Size Preferences: Implications for Programming of Health and Social Services," in *The Negro American*, T. Parsons and K. B. Clark (eds.), 1967.

4. P. Neal Ritchey, *Migration and Fertility: A Study of the Social Factors Involved*, Doctoral dissertation, University of Georgia.

# 11. The Intervening Effects of Marital Status on the Fertility of Rural-Urban and Urban-Rural Migrants

P. Neal Ritchey\*

## 11.1 INTRODUCTION

The effect of migration between rural and urban areas on fertility is important both from short- and long-term perspectives. Of concern is the extent to which the reproductive behavior of migrants is similar to that of the population of the area at origin or that of the indigenous population at destination. If consistent with their rural background, urban in-migrants have high fertility, and this fertility contributes to immediate population pressures in urban areas. If rural destination effects an increase in the fertility of in-migrants of urban background, then migration from urban-to-rural areas contributes to an increase in overall fertility.

Long-term considerations depend on the net migration between rural and urban areas. The dominant direction of migration has been from rural-to-urban areas, and urbanization has resulted in lower fertility. But the rate of decrease in fertility may be retarded by urban-to-rural migration.

Previous research has generally focused on the fertility of married white rural-to-urban migrants. Our knowledge of the reproductive behavior of black migrants and of urban-rural migrants is minimal. Equally important, the restriction to populations that were married has limited the assessment of the impact of migration on rural and urban fertility. Thus, the major thrust of this paper was the intervening effects of marital status on the fertility of the residence background populations.

## 11.2 METHODS

These findings are an extension of the author's doctoral dissertation, *Migration and Fertility: A Study of the Social Factors Involved*.<sup>1</sup> The data source for this analysis was the 1967 Survey of Economic Oppor-

tunity, a national sample. Rural and urban areas were defined using the 1960 census definition. Places of 2,500 or more population and densely settled areas around places of 50,000 or more population in 1960 were designated as urban; all other areas were designated as rural.

Because the Survey of Economic Opportunity (SEO) utilizes 1960 census residence definitions, the rural population as coded in the 1967 survey was greater (and the urban population smaller) than was actually the case. A substantial proportion of the excess rural population is concentrated in the category of rural women with urban background. Many of these are women who have moved from cities into areas which would have been reclassified as urban if the residence classifications had been updated. The influence of this problem on the findings of this paper cannot be assessed at this time, but would be in the direction of reducing the number and proportion of urban-rural migrants found in the various analytical groups.

For the sample design, definitions, limitations, and procedure of analysis, the reader is referred to the dissertation.

## 11.3 FINDINGS

### 11.3.1 Number of Women and Fertility by Residence Background

Urban areas in 1967 had an estimated 19.1 million white women and 2.7 million black women 20–44 years of age (Table 11.1). Similar proportions of white and black urbanites were rural in origin, 17.9 and 18.9%, respectively. Only slight variations occurred in proportions by residence background as marital status became more homogeneous.

Rural women 20–44 years old in 1967 were comprised of 7.7 million white and 581,000 blacks. Racially, the proportion of rural women with urban background differed sharply. Almost a third of white rural women had urban background regardless of the

\*Work supported in part by the Department of Sociology, University of Georgia, Athens.

**Table 11.1. Number and percent distribution of urban and rural women, age 20–44, by residence background, marital status, and race, 1967<sup>a</sup>**

Residence background	Numbers in thousands							
	White		Black		White		Black	
	No.	%	No.	%	No.	%	No.	%
	<b>Total</b>				<b>Ever married</b>			
Total urban women	19,109	100.0	2,702	100.0	16,485	100.0	2,238	100.0
Urban-of-urban origin	15,687	82.1	2,192	81.1	13,356	81.0	1,791	80.0
Rural-urban migrants	3,422	17.9	510	18.9	3,129	19.0	447	20.0
Total rural women	7,710	100.0	581	100.0	7,017	100.0	470	100.0
Urban-rural migrants	2,280	29.6	74	12.7	2,139	30.5	71	15.1
Rural-of-rural origin	5,430	70.4	507	87.3	4,878	69.7	399	84.9
	<b>Ever married, spouse present</b>				<b>Married once, spouse present</b>			
Total urban women	14,779	100.0	1,521	100.0	13,045	100.0	1,259	100.0
Urban-of-urban origin	11,954	80.9	1,198	78.8	10,557	80.0	988	78.5
Rural-urban migrants	2,826	19.1	323	21.2	2,489	19.1	271	21.5
Total rural women	6,646	100.0	387	100.0	5,865	100.0	342	100.0
Urban-rural migrants	2,008	30.2	65	16.8	1,739	29.7	57	16.7
Rural-of-rural origin	4,637	69.8	322	83.2	4,126	70.3	285	83.3

<sup>a</sup>Numbers are independently rounded; therefore, column sums may not equal total.

Source: 1967 Survey of Economic Opportunity.

marital-status grouping considered. In contrast, about one in every eight rural blacks was an urban-to-rural migrant. Among women married once, the proportion with urban experience was somewhat higher — one in six.

The major differences in reproduction were between blacks and whites and between rural and urban populations (Table 11.2).

Rural white women had 2600 children per 1000 women as compared with 2242 children for urban whites. The receiving area exerted a greater influence on the fertility of migrants than the sending area. Thus, rural whites of rural origin (2638) and urban-to-rural migrants (2507) were at one extreme with rural-to-urban migrants (2370) and urbanites of urban origin (2213) at the other.

The apparently greater influence of the receiving areas was, to a considerable extent, a function of differences in the proportions of married women. This was especially the case among rural women. The fertility of ever-married women maintained the same order, but the gap between children born to indigenous rural women and urban-to-rural migrants widened. Among women in urban areas and urban-to-rural migrants, the difference narrowed. When comparisons were made among women married once with spouse present, the pattern was even clearer. Among these women urbanites of urban background had 2486 children; rural-to-urban migrants,

2509; urban-to-rural migrants, 2588; rural women of rural background, 2886. Thus, when the effects of marital status are eliminated, urban experience exerted a greater influence than rural experience, regardless of whether such experience was at origin or destination.

Rural-urban differentials were more pronounced among blacks. Rural black women (3954) averaged one child more per woman than did their urban counterparts (2918). The startling finding, however, was the drastic reduction in childbearing accompanying rural-to-urban migration. The average number of children was lower among urban blacks of rural background than among indigenous urban blacks. The proportions ever married and the proportions married and living with spouse did mediate this relationship. However, these factors tended to increase the magnitude of the differences while maintaining the direction. Whereas, among total women, rural-urban migrants has 2889 children and the indigenous blacks 2924, among women married once living with their husbands, the rates were 2989 and 3156, respectively. It must be cautioned, particularly in reference to the higher fertility found among indigenous urban blacks than among black rural-urban migrants, that the comparisons that have been made utilized only the residence background of women. Within the receiving populations are women married to men who are in-migrants. Other research of the author has indicated that, when both residence

Table 11.2. Age-standardized rates of children ever born per 1000 urban and rural women, age 20-44, by residence background, marital status, and race, 1967

Residence background	White	Black	White	Black
	<b>Total</b>		<b>Ever married</b>	
Total urban women	2242	2918	2446	3168
Urban-of-urban origin	2213	2924	2429	3192
Rural-urban migrants	2370	2889	2513	3063
Total rural women	2600	3954	2759	4324
Urban-rural migrants	2507	3950	2621	4062
Rural-of-rural origin	2638	3956	2821	4364
	<b>Ever married, spouse present</b>		<b>Married once, spouse present</b>	
Total urban women	2487	3077	2490	3119
Urban-of-urban origin	2479	3107	2486	3156
Rural-urban migrants	2520	2961	2509	2989
Total rural women	2772	4389	2764	4433
Urban-rural migrants	2619	4108	2588	4125
Rural-of-rural origin	2836	4434	2836	4471

Source: 1967 Survey of Economic Opportunity.

backgrounds of husband and wife are considered, black rural-urban migrants have nominally higher fertility than indigenous urban blacks (see the following chapter, "The Fertility of Negroes without Southern Rural Experience: A Reexamination of the 1960 GAF Study Findings with 1967 SEO Data").

The fertility of urban-to-rural migrants was nearer that of the receiving rural population among blacks than among whites. Again, control of marital status had the effect of widening the differences in fertility. Still, for black women married once living with spouse, the rate for urban-rural migrants (4125) was less than that for rural blacks of rural origin (4471) and substantially higher than the rate for urban blacks (3119). It should be noted, however, that the rates for urban-to-rural blacks are based on a relatively small number of cases and thereby subject to greater sampling variability.

In every instance, the number of children ever born to blacks was substantially higher than that for their white counterparts. There was, however, considerable variation by residence, marital status, and residence background. In rural areas, blacks had 1300 to 1700 more children per 1000 women than did whites. In urban areas racial differentials were not so great. These blacks had 500 to 700 more children per 1000 women than did whites. The least differences in fertility between blacks and whites occurred among rural-urban migrants, the greatest among the populations of urban origin.

### 11.3.2 Marital Status and Residence Background of Women

A general pattern of variation in marriage, marital stability, and remarriage occurred among both black and white urban-to-rural and rural-to-urban migrant women. In contrast to their counterparts in both *sending and receiving areas*, migrants had:

1. Smaller proportions that had never been married and, conversely, greater proportions that had been ever married.
2. Greater proportions of the married living with husbands.
3. Similar or smaller incidences of spouse absent, with one exception (white urban-to-rural migrants vs the receiving rural population).
4. Slightly larger proportions remarried and living with their husbands.
5. Greater proportions married once with husband present (Table 11.3).

The successive inclusion of women with limited exposure (e.g., divorced, separated, or never married) to the risk of pregnancy requires averaging births over a larger base of women. Among sending and receiving populations, proportionately more women have limited or no exposure. Therefore, as the marital-status classification was controlled, the effect of *each* of the five

Table 11.3. Number and percent distribution of urban and rural women, age 20-44, by marital status and residence background, 1967<sup>a</sup>

Marital status	Numbers in thousands											
	White		Negro		White		Negro		White		Negro	
	No.	%	No.	%	No.	%	No.	%	No.	%	No.	%
	<b>Total urban</b>				<b>Urban background</b>				<b>Rural background</b>			
Total urban women	19,109	100.0	2,702	100.0	15,687	100.0	2,192	100.0	3,422	100.0	510	100.0
Never married	2,624	13.7	464	17.2	2,331	14.9	401	18.3	293	8.6	63	12.4
Ever married	16,485	86.3	2,238	82.8	13,356	85.1	1,791	81.7	3,129	91.4	447	87.6
Ever married, spouse absent	1,706	8.9	717	26.5	1,402	8.9	593	27.0	303	8.9	124	24.3
Ever married, spouse present	14,779	77.4	1,521	56.3	11,954	76.2	1,198	54.7	2,826	82.5	323	63.3
Married more than once, spouse present	1,734	9.1	262	9.7	1,397	8.9	210	9.6	337	9.8	52	10.2
Married once, spouse present	13,045	68.3	1,259	46.6	10,557	67.3	988	45.1	2,489	72.7	271	53.1
	<b>Total rural</b>				<b>Urban background</b>				<b>Rural background</b>			
Total rural women	7,710	100.0	581	100.0	2,280	100.0	74	100.0	5,430	100.0	507	100.0
Never married	693	9.0	111	19.1	141	6.2	3	4.1	552	10.2	108	21.3
Ever married	7,017	91.0	470	80.0	2,139	93.8	71	95.9	4,878	89.8	399	78.7
Ever married, spouse absent	371	4.8	83	14.3	131	5.7	6	8.1	241	4.4	77	15.2
Ever married, spouse present	6,646	86.2	387	66.6	2,008	88.1	65	87.8	4,637	85.4	322	63.5
Married more than once, spouse present	781	10.1	45	7.7	269	11.8	8	10.8	511	9.4	37	7.3
Married once, spouse present	5,865	76.1	342	58.9	1,739	76.3	57	77.0	4,126	76.0	285	56.2

<sup>a</sup>Numbers are independently rounded; therefore, column sums may not equal total.

Source: 1967 Survey of Economic Opportunity.

factors listed above was to promote a higher level of fertility among migrants in comparison with sending and receiving populations.

For married-once white women living with husbands, the number of children ever born was highest among indigenous rural women, lower for urban-rural migrants, lower still for rural-urban migrants, and lowest among indigenous urban women. The latter three classes have similar levels of fertility. For total white women, the ordering by residence background was the same, but the magnitude and clustering of rates was changed. The magnitude of difference in rates between urbanites of urban and of rural background was greater. More women married once and living with spouse (73% for rural-urban migrants, 67% for women of urban background) and fewer never-married women (9 and 15%, respectively) sustained the level of fertility among women of rural background as that among indigenous urban women drops.

Urban-to-rural migrants had even higher proportions of women married once (76%), fewer never married (6%), and slightly more remarried and living with husband. These factors combined to sustain a higher rate of fertility among total women. The effect was to broaden the differences between groups — even between rural-urban and urban-rural migrants among total white women. Finally, a large downward shift was apparent among indigenous rural women when marital status was not controlled. Principally responsible for the lower rate was the large proportion of never-married women (10%). Whereas rates were clustered among women married once, they appeared evenly spaced among total women.

#### 11.4 CONCLUSIONS

Migrants comprised sufficient proportions of urban and rural populations to affect overall fertility. The

questions of practical interest are two: Does the fertility of rural-urban migrants disproportionately increase the rate of population growth in urban areas; and does that of urban-rural migrants disproportionately lessen the rate of population growth in rural areas. The findings for whites provided some insight into these questions. Among blacks, a number of factors, such as length of marriage before separation of spouse, spacing of children, illegitimacy, and the data limitation of considering only the female's residence background rendered the interpretations less straightforward. Therefore, this discussion was limited to whites.

Previous research has been limited to the study of the fertility of married women. Findings of this study indicated that among white married women, rural-urban migrants have only slightly higher fertility than that of indigenous urban women, and urban-rural migrants lower fertility than that of indigenous rural women. On this basis, rural-urban migrants contributed only slightly to higher population growth in urban areas and urban-rural migrants to a medium extent to less rapid population growth in rural areas.

However, in general, migrants were more often than indigenous sending and receiving populations to have

been ever married and be married and living with spouse — including being in a sustained first marriage and being remarried. The disproportionate concentration of migrants in these marital statuses and, conversely, the greater propensity for indigenous women to be single, or otherwise less exposed to the risk of childbearing, increased the impact of migration on fertility in both rural and urban areas.

Proportionately more migrants and fewer indigenous women bear children. Therefore, when marital status intervened in this manner, the effects of migration on fertility resulted in a moderate increase in the rate of population growth in urban areas and a substantial lessening of the rate of population growth in rural areas.

Since migration and its association with marital status effected an increase in urban fertility and a decrease in rural fertility, the rural-urban differential in fertility was reduced by migration. This differential was, in fact, almost 20% greater among whites when the migrant populations were excluded.

In summary, when the intervening effects of marital status are taken into account, the impact of migration on both urban and rural fertility was considerably more than that implied in previous research.

## 12. Race, Poverty, and Educational Achievement in an Urban Environment

Margaret M. Williams

### 12.1 INTRODUCTION

The educational achievement of black children as a class is generally below that of white children. Any discussion of the reasons for this gap must consider historic and existent black and white economic and social inequalities, and the extent to which these inequalities affect ability differences. However, it is increasingly evident that a simple equating of black and white economic levels is impossible. Blacks earn lower wages than whites for the same occupations.<sup>1</sup> Black families usually live in a much poorer neighborhood as regards both physical conditions<sup>2</sup> and housing quality<sup>3</sup> than white families of the same income level. Therefore, the question of whether black children achieve less because they are black (a genetic interpretation) or because they are deprived environmentally is at yet unanswered. The present study is an attempt to throw some light on this question. The independent and interacting effects of poverty and race on educational achievement were examined for a large sample of urban children. Results indicated that achievement decrements are much more highly related to poverty than to race.

Welfare rates were the only source of recent poverty data available at the time this study was conducted. Welfare rates are not as sensitive a measure of area economic level as is mean income level. Therefore, these rates should be regarded as interim economic measures until Fourth Count census data are available. This study will then be repeated, substituting income data for welfare data.

### 12.2 METHOD

#### 12.2.1 Data

The three sets of data described below were provided by the St. Louis, Missouri, Board of Education.\*

**Achievement data.** The Iowa Tests of Basic Skills (ITBS) was given at four points in time (4th grade, Fall 1968; 5th grade, Fall 1969, Spring 1970; 6th grade, Spring 1971) to all public school children in these grades, about 7000 children on each occasion. (Because of school absenteeism and high mobility rates, these occasions do not necessarily represent the same children.)

These data were reported as grade equivalent composite scores, based on the various verbal and numerical portions of the ITBS, for each child in the sample. A grade equivalent score is interpreted thus: a score of 4.2 indicates an academic achievement level (as measured by the ITBS) equivalent to that of the normal child who has completed two months of the 4th grade. The scores are decimalised on the assumption that a school year is ten months.

**Rate data.** The race mix of each school was given as the percentage of black pupils attending each school. Since children generally attended schools that were either 100% white or over 95% black, school race mix provided an accurate measure of each child's race. Children were classified as black if attending a school where 50% of children were black and vice versa for white.

**Poverty data.** The percentage of children in each school neighborhood who received Aid to Dependent Children (ADC) was known and used as an estimate of an individual child's neighborhood poverty level, and thus enabled children to be classified into four poverty groups<sup>†</sup> chosen to provide the most equitable poverty group frequencies.

---

\*Through the courtesy of Dr. Gerald Moeller, Director of Research and Evaluation, and Mr. Douglas Benn, Director of Data Processing. All analyses and interpretations are solely the responsibility of the author.

<sup>†</sup>"Least poor" = 0-14.9% ADC; "poor" = 15.0-29% ADC; "very poor" = 30.0-44.9% ADC; "extremely poor" = 45.0-69% ADC.

12.2.2 Analysis

Schools where more than 25% of pupils in grades 4, 5, or 6 were bussed from other neighborhoods were discarded from the analysis, since the neighborhood poverty data might be inapplicable.

Composite mean ITBS scores were calculated separately for blacks and whites for each poverty group for each point in time. Multiple regression equations were then calculated for each point in time to show the relative weightings of the race and poverty variables as predictors of ITBS scores. For the latter calculations the race and poverty variables were ungrouped.

12.3 RESULTS

Figure 12.1 shows that the results for each point in time are very similar, the white "least poor" group in any grade being about a school year ahead of the "extremely poor" black group as regards educational achievement. However, when black and white children within a poverty level are compared, differences are much smaller and are negligible or nonexistent for the "poor" group. The detailed results for the 6th grade, Spring 1971, testing show clearly the equitable performance of the black and white "poor" groups (Table 12.1).

The multiple regression equations for each grade (Table 12.2) show that the poverty variable (*P*) is four to six times greater than the race variable (*R*) as a predictor of ITBS scores.

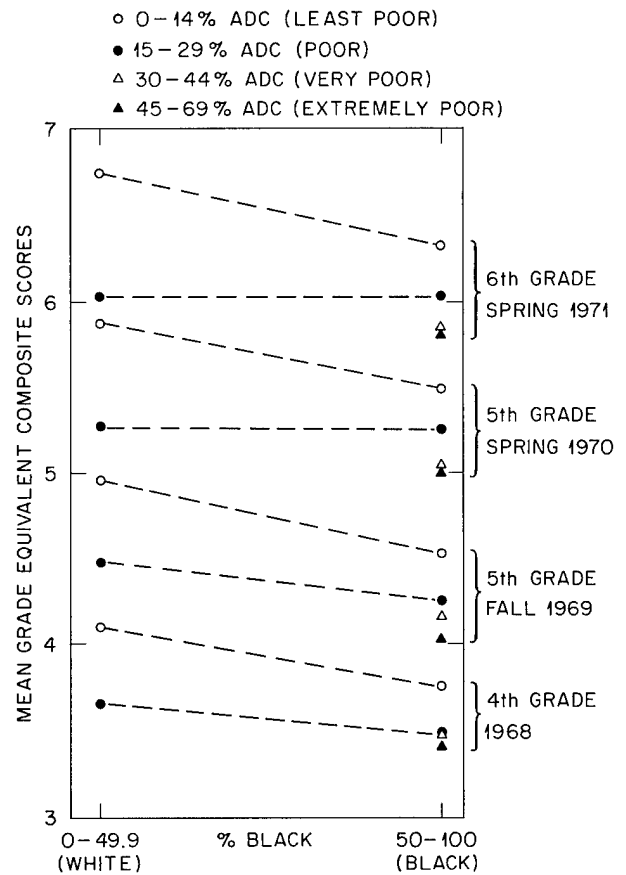

Fig. 12.1. Mean ITBS composite scores for four race-poverty groups at four points in time.

Table 12.1 Means and standard deviations for the 6th grade, Spring 1971, ITBS scores by race mix and poverty levels

Variable	Percent on ADC				Overall
	0-14.9 (Least poor)	15-29.9 (Poor)	30-44.0 (Very poor)	45-69 (Extremely poor)	
<b>Black</b>					
N	275	1053	1722	1115	4165
Mean	6.29	6.01	5.84	5.80	5.90
SD	1.23	1.17	1.09	1.06	1.11
<b>White</b>					
N	1802	602	0	0	2404
Mean	6.71	6.02	0	0	6.54
SD	1.22	1.11	0	0	1.19
Grand totals: Mean, 6.13; SD, 1.14; N, 6569					

Multiple regression equation:  $X = 6.99 - 0.0088R - 0.049P + 0.00041 P \times R$   
 Standard deviations of regression coefficients: 0.037 0.00060 0.0032 0.000034

Table 12.2 Race and poverty as predictors of ITBS scores using the multiple regression technique

Grade	Year	Multiple regression equation <sup>a</sup>
4	1968	$X = 4.3 - 0.0060R - 0.028P + 0.00023P \times R$
5	1969	$X = 5.1 - 0.0059R - 0.025P + 0.00016P \times R$
5	1970	$X = 6.09 - 0.0069R - 0.036P + 0.00028P \times R$
6	1971	$X = 6.99 - 0.0078R - 0.049P + 0.00041P \times R$

<sup>a</sup>Using analysis of variance, the  $P \times R$  interaction was found to be highly significant.

The predicted mean 6th grade achievement for a school where all children are white and none receive ADC would be  $X = 6.99$ , since the  $P$  and  $R$  terms become zero. Predicted mean achievement in another actual school where all children are black ( $R = 100$ ) and 63% are on ADC ( $P = 63$ ) would be:

$$\begin{aligned}
 X &= 6.99 - (0.0078 \times 100) - (0.049 \times 63) \\
 &\quad + (0.00041 \times 100 \times 63) \\
 &= 6.99 - 0.78 - 3.09 + 2.60 = 5.72.
 \end{aligned}$$

Race accounts for a decrement of about 8 months and "extreme" poverty for a decrement of 3.09 years, while the fact that this particular school is both poor and black accounts for an increment of 2.60 years. Thus, the overall predicted result is a decrement of 1.27 years of achievement for the 6th grade in this school, compared with 6th graders from an all-white, non-ADC school.

#### 12.4 DISCUSSION

The results show a clear relationship between neighborhood economic level and school achievement. The economic level of the "poor" black and "poor" white

neighborhoods were probably more alike than the neighborhood economic levels for the two races for the "least poor" groups. Since welfare payments, unlike wages, do not vary with race, it is suggested that economic differences between blacks and whites disappear as percentage on ADC rises. This is reflected in the more equitable performances of black and white children from "poor" neighborhoods. Because of the inequalities in rents, wages, etc., the economic level of black "least poor" neighborhoods, where few families are on welfare, was probably below that of white low-welfare neighborhoods. Such economic detriments were reflected in the lower educational achievement of the black children involved. The hypothesis that racial economic differences disappear as percent on welfare in a neighborhood increases will be tested when Fourth Count census data are available.

The positive interaction of the race and poverty variables, reflecting an increment in achievement when neighborhoods are both black and poor, is contrary to expectations and may be related to the impact of federally funded Title I assistance. These funds are supposed to go to the poorest schools, which are often the blackest. The close association between achievement and economic level demonstrated in this paper strongly suggests that federal programs be directed at the economic improvement of the families and neighborhoods in which underachieving children live.

#### REFERENCES

1. U.S. Department of Labor, "Income and Levels of Living," *Mon. Labor Rev.* 91(3), 90-96 (March 1968).
2. Margaret M. Clarke, *Black-White Ghettos: Quality of Life in the Atlanta Inner City*, ORNL-HUD-25 (September 1971).
3. Garret A. Vaughn, *A Comparison of White and Non-White Metropolitan Low Income Housing*, Ph.D. Thesis, Duke University, Department of Economics, 1970.

## II. Civil Defense Systems Analysis

---

### 13. Analysis of Effects of Nuclear Weapon Overpressures on Hasty Pole Shelters

C. V. Chester R. O. Chester

#### 13.1 SUMMARY

Open hasty shelters, similar to those described in Russian civil defense manuals, were analyzed for (1) the transient internal pressures and (2) the dynamic response of the roof. The transient internal pressure will exceed the external pressure as the external pressure falls. If this excess, called differential shelter overpressure (DSOP), is greater than about 0.13 atm (2 psi), the possibility exists of lifting the earth-covered roof off the shelter.

The analysis showed that for shocks of 2 atm or greater, this critical pressure is exceeded for large values of the ratio of shelter volume to the product of entrance area and positive phase duration. For incident shocks of 1 atm or less, the negative pressure on the roof never exceeds 2 psi. It was discovered that reflected shocks from nearby obstacles reaching the shelter entrance during the decay of the initial overpressure cause a dramatic increase in the observed peak DSOP.

The response of the roof to the initial positive (downward) pressure was estimated by assuming that the stress-strain curve of the green hardwood poles supporting it could be approximated by an elastic-plastic member with a yield stress of 8000 psi and ultimate strain six times yield strain. Tests on poles supported these assumptions. It was discovered that an open shelter of interest will survive some 50% more overpressure (22 psi) from 200-kiloton weapons than the same shelter with closed doors (15 psi).

#### 13.2 INTRODUCTION

The hasty pole shelter is one design of fallout shelters included by the Russians in their civil defense plans for

evacuating, dispersing, and sheltering their population<sup>1</sup> (see Fig. 13.1). The prototype chosen for study has an entrance area of 4.4 ft<sup>2</sup> and total volume options of 485 and 700 ft<sup>3</sup>. This shelter has been improved and field tested by Kearny,<sup>2</sup> who demonstrated that it could be constructed in less than 48 hr by the untrained rural occupants using available tools. The shelter is intended for fallout protection in rural areas, and not primarily for blast protection. However, the survival of earth-covered, wooden-framed shelters at Hiroshima and Nagasaki at incident overpressures greater than 20 psi suggested that such hasty pole shelters may have considerable blast resistance. Two modes of failure are analyzed in this study: (1) loss of the roof by transient pressurization of the open shelter followed by lifting of the roof as the external pressure decays more rapidly than the interest and (2) dynamic collapse of the roof from external pressure after elastic-plastic yielding of the roof poles.

#### 13.3 TRANSIENT INTERNAL PRESSURES IN OPEN SHELTERS

##### 13.3.1 Experimental

A plywood model with interior dimensions 1/24th those of the prototype shelter was mounted on a 4-in.-ID explosively driven shock tube (Fig. 13.2). Pressures inside the shelter and tube were sensed by flush-mounted Kistler-type 607L pressure transducers. The output of the transducers, after suitable amplification, was recorded on an oscilloscope. The shock wave was generated by the detonation of 2 to 5 g DuPont Detasheet C<sup>®</sup> by means of a No. 6 electric blasting cap at the closed end of the shock tube 18 ft from the shelter entrance.

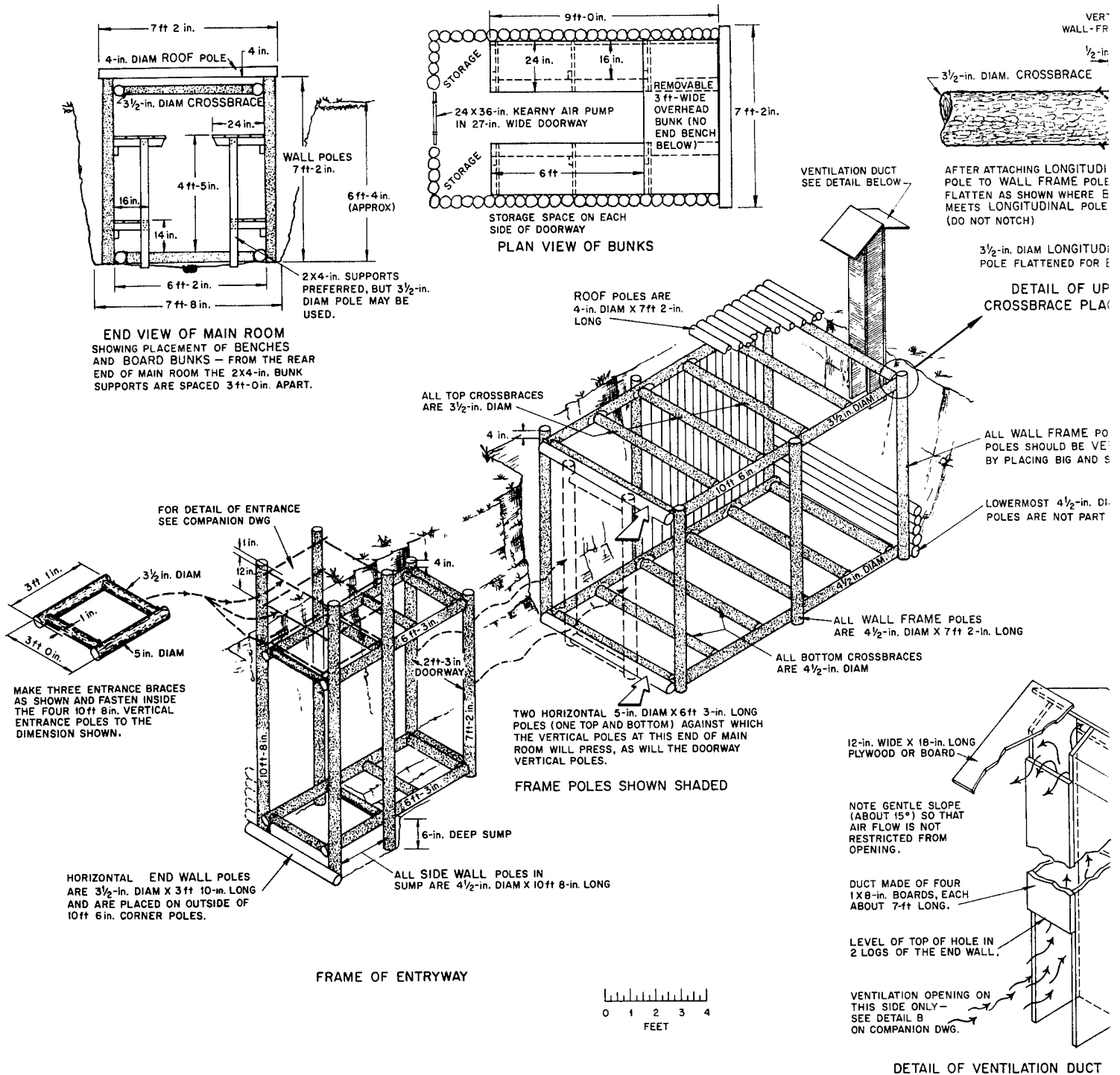

Pictorial View of Small-Pole Shelter.  
 Fig. 13.1. Pictorial view of hasty pole shelter.

(1)

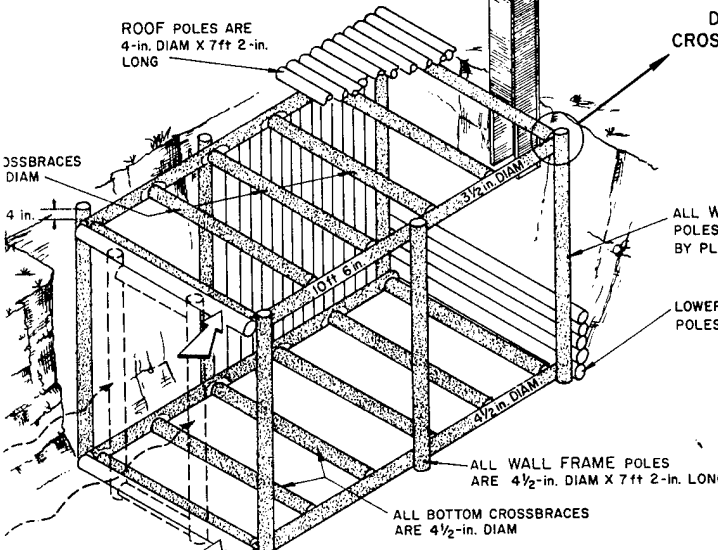
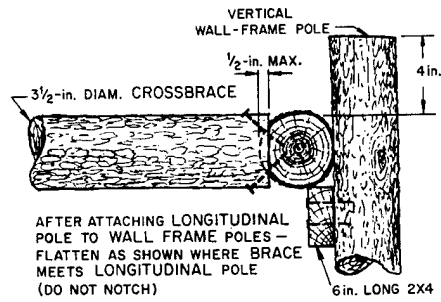
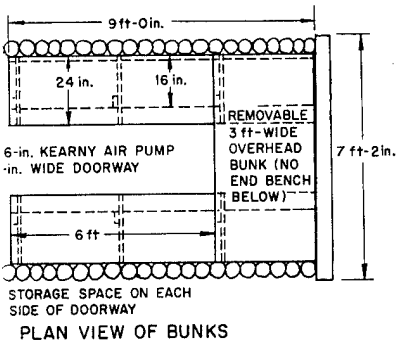

3 1/2-in. DIAM LONGITUDINAL  
POLE FLATTENED FOR BRACE  
DETAIL OF UPPER  
CROSSBRACE PLACEMENT

ALL WALL FRAME POLES AND WALL  
POLES SHOULD BE VERTICAL - ALTERNATE  
BY PLACING BIG AND SMALL ENDS UP.

LOWERMOST 4 1/2-in. DIAM X 7ft 2 in. END WALL  
POLES ARE NOT PART OF FRAME.

TWO HORIZONTAL 5-in. DIAM X 6ft 3-in. LONG  
POLES (ONE TOP AND BOTTOM) AGAINST WHICH  
THE VERTICAL POLES AT THIS END OF MAIN  
ROOM WILL PRESS, AS WILL THE DOORWAY  
VERTICAL POLES.

FRAME POLES SHOWN SHADED

SUMP

POLES IN  
DIAM X 10ft 8-in. LONG

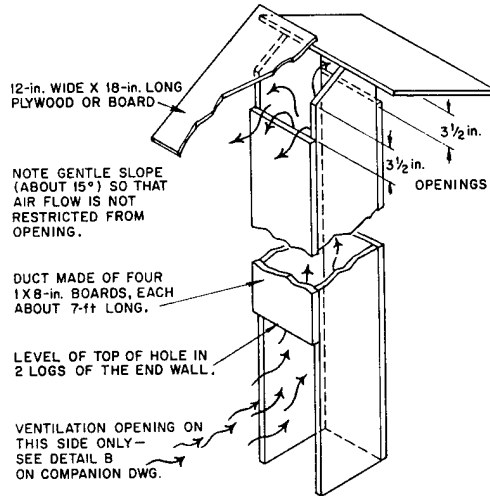
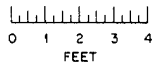

DETAIL OF VENTILATION DUCT

Pictorial View of Small-Pole Shelter.

Fig. 13.1. Pictorial view of hasty pole shelter.

(2)

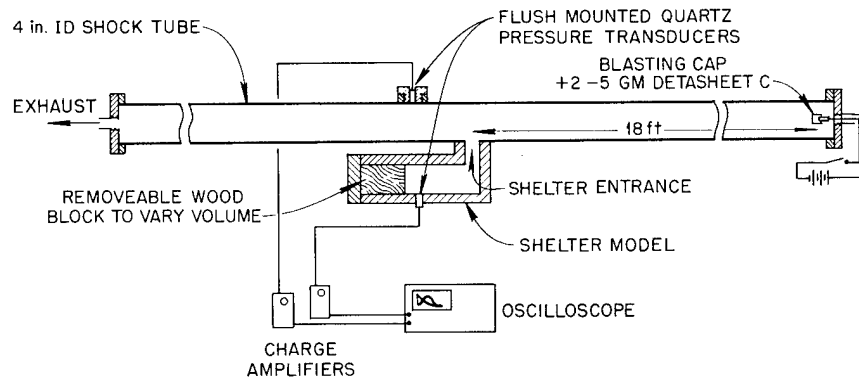

Fig. 13.2. Experimental arrangement for shock tube tests.

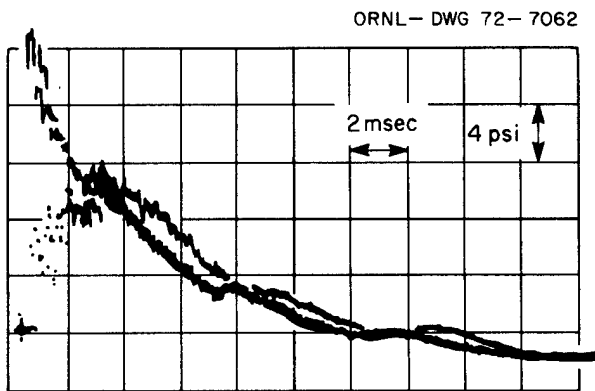

Fig. 13.3. Pressure vs time in model shelter and shock tube.

Figure 13.3 is a typical recording of both the pressure in the shelter and in the shock tube. The pressure in the shock tube rises abruptly to about 22 psi and then decays, becoming negative about 12  $\mu$ sec later. This models the pressure from a 2.7-kiloton explosion on the full-scale prototype. The shock tube pressure has several small positive jumps as it decays, caused by reflections in the tube. These can cause significant increases in the observed maximum differential shelter overpressure (see Sect. 13.3.2). The pressure in the shelter rises more slowly, to a maximum of 12 psi in about 3  $\mu$ sec. The minimum DSOP that would lift the roof is about 2 psi.

### 13.3.2 Computation

While experiments are very useful for identifying the important phenomena and evaluating empirical constants, machine computation is more economical for parameter exploration. Since the fluid flows here are

dominated by inertial forces (as opposed to viscous or gravitational forces), Eulerian scaling should be quite accurate. In this scaling, pressures, stresses, and velocities are invariant, and time and distance are scaled.

The complex phenomena associated with nuclear explosions are avoided in the mathematical model by using empirical overpressure vs time data from "Effects of Nuclear Weapons" by Glasstone.<sup>3</sup> Quantitative information on the negative phase was assembled from Brode<sup>4</sup> and Hillendahl<sup>5</sup> (Figs. 13.4 and 13.5). The other complicated physical situation avoided in the mathematical description is the complex flow at the shelter entrance. The sonic choke condition is recognized by limiting the flow to a pressure ratio of 0.58, that for sonic flow at ambient conditions. Below this flow, ignorance of the details of pressure drop is lumped into a discharge coefficient for the entrance. This coefficient is evaluated separately for filling and emptying by making the computed filling time and maximum DSOP agree with (or at least approximate) experimental observations. The values obtained were 0.60 on filling and 0.30 on emptying. The lower coefficient on outflow had been observed earlier in steady flow tests of a model of a similar entranceway. The differential equation governing the flow of air in and out of the shelter is:

Flow in,

$$\frac{dP}{dt} = \sqrt{\frac{2\gamma}{M^2}} P^{1+1/\gamma} (P_{\text{out}} - P)^{1/2} .$$

Flow out,

$$\frac{dP}{dt} = \sqrt{\frac{2\gamma}{M^2}} P^{1+1/\gamma} (P - P_{\text{out}})^{1/2} ,$$

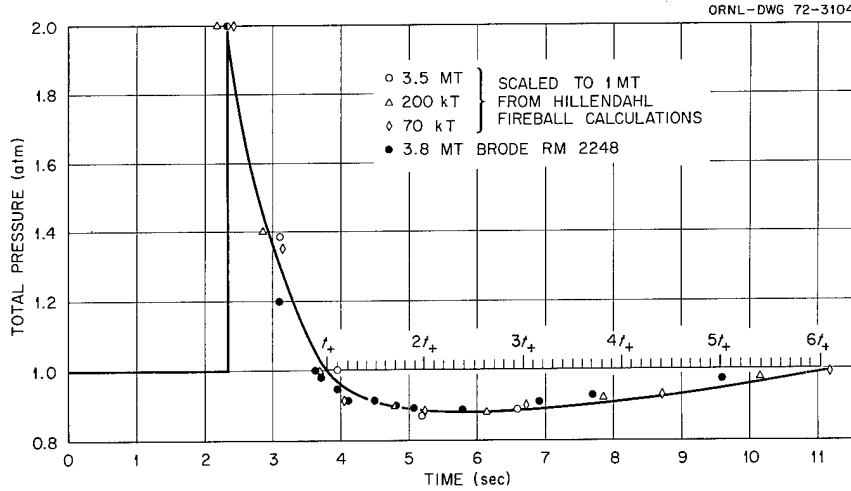

Fig. 13.4. Complete pressure-time curve for 1-atm shock from 1-MT weapon.

where

$$M = \frac{V}{At_+ Y C_0}, \text{ "Mach number,"}$$

$P$  = total pressure in shelter, atm,

$P_{out}$  = total external pressure, atm, subject to limitation of that value used in equation  $\leq P/0.58$  (sonic flow),

$t$  = time, units of  $t_+$ ,

$t_+$  = duration of positive phase,

$V$  = volume of shelter,

$A$  = area of entrance,

$Y$  = discharge coefficient of entrance,

$C_0$  = initial speed of sound in shelter,

$\gamma$  = ratio of specific heats of air.

It is convenient to group all the scaled parameters into a dimensionless parameter  $M$ , which is a fictitious Mach number. Physically, it is the hypothetical velocity (not realized) in the entranceway required to fill the shelter to the incident overpressure during the positive phase. Practically, by carrying out the extensive machine computations of pressure for a few values of Mach number, the behavior of a large combination of shelters and positive phase durations is determined.

Figure 13.6 is a plot of pressure inside and outside the shelter vs time for a 1-atm incident shock and Mach numbers of 0.5, 1.0, 2.0, and 4.0 (on filling).

The time required for the pressure to reach a maximum is plotted in Fig. 13.7. By using a discharge coefficient of 0.6 for the entrance on filling, excellent

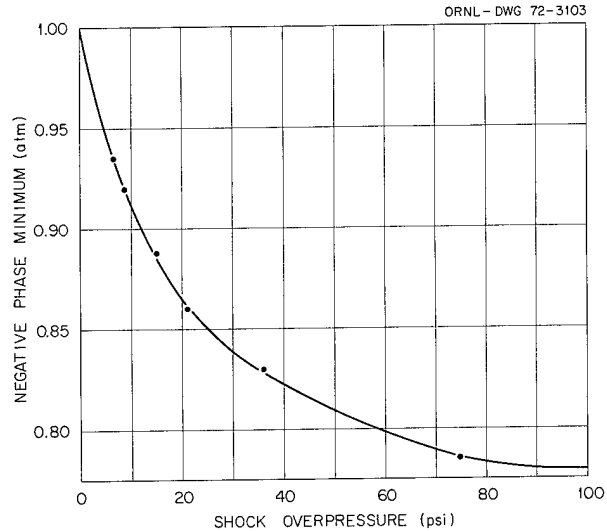

Fig. 13.5 Negative phase minimum vs peak incident shock overpressure.

agreement between the calculations and experimental observations was obtained.

The discharge coefficient on emptying is much more subject to error. In the first place, it is evaluated from the small difference of two larger numbers, the pressure inside and outside, both of which have a large noise component. In the second place, the shock incident on the entrance had positive jumps (mentioned earlier) during its decay, which significantly increase the maximum DSOP. The effects of these jumps can be seen by comparing Figs. 13.8 and 13.9. In the computations for Fig. 13.8, a  $0.2 P_{max}$  jump was added to the decaying shock at  $0.2t_+$ , and in Fig. 13.9, the shocks are ideal.

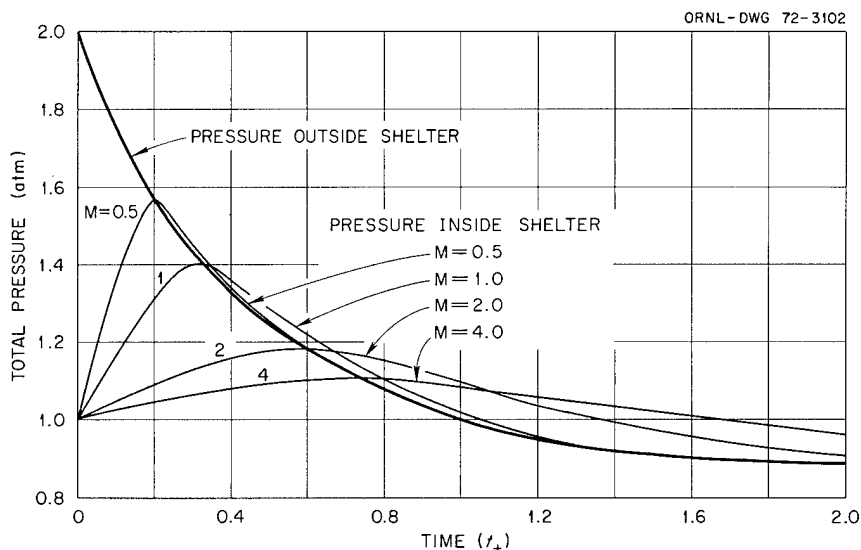

Fig. 13.6. Pressure inside and outside the shelter vs time as a fraction of weapon positive overpressure phase.

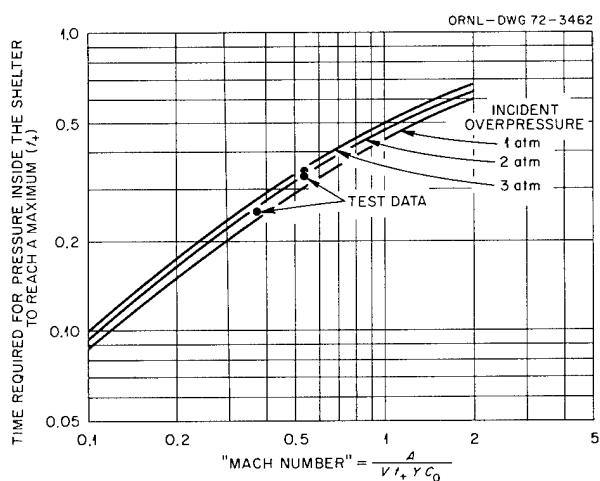

Fig. 13.7. Time for shelter pressure to peak vs M.

Hence, the agreement between the observations and calculation is not as good as for the filling time. However, the difference is within the estimated uncertainty, indicated by the error bars on the points on Fig. 13.8.

Jumps on the back of a shock are of more than mathematical interest. They would be experienced in a real situation if a large object such as a hill or building were situated a few hundred feet away to reflect a shock at the shelter entrance a few tenths of a second after the main shock arrives. In many instances this is likely to be the real circumstance, rather than the flat open terrain usually assumed.

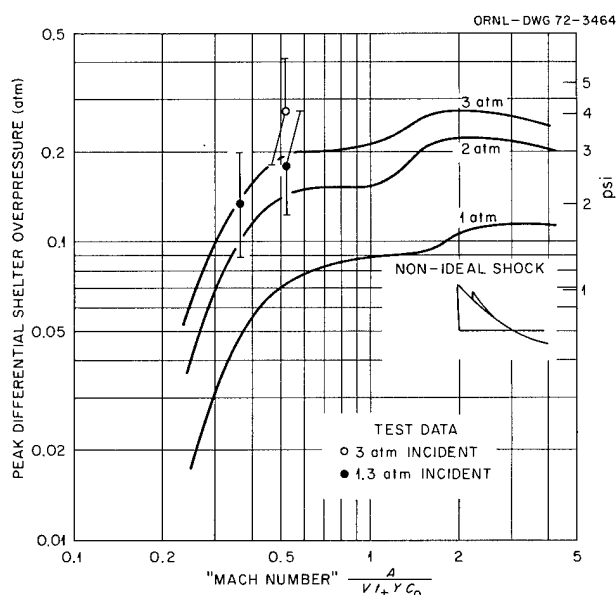

Fig. 13.8. Peak DSOP vs M (shock with reflections).

In order to lift a roof with 3 ft of earth cover, a negative pressure on the roof of approximately 2 psi must be exceeded. The analysis shows that this would not happen for a 1-atm shock, and could occur only at very high values of Mach number (corresponding to very large shelters, small entrances, and very small weapons) for a 1.5-atm shock. Only after the incident overpressure reaches 2 or 3 atm is 2 psi exceeded on the roof for interesting shelter sizes and weapon yields.

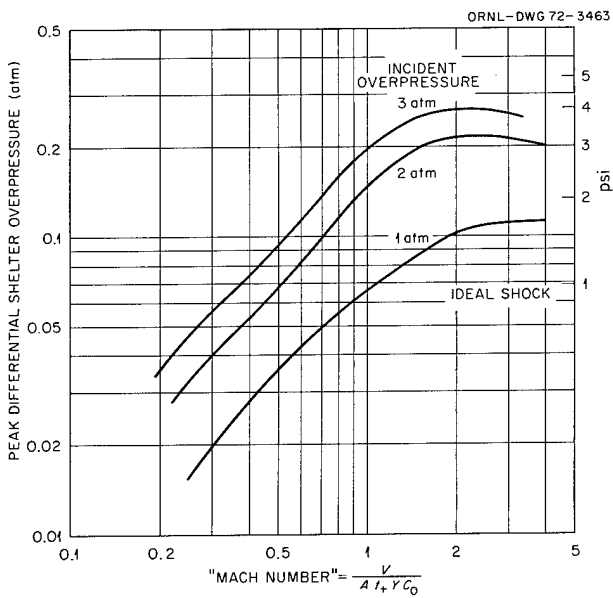

Fig. 13.9. Peak DSOP vs  $M$  (ideal shock).

(For 200 kilotons,  $1 \text{ m}^3$  per person,  $M = 1$  corresponds to a shelter with 200 spaces per square meter of entrance area.)

As will be shown in the next section, 2 or 3 atm will exceed the strength of the roof.

### 13.4 RESPONSE OF EARTH-COVERED POLE ROOFS TO BLAST LOADING

#### 13.4.1 Properties of Wood Poles

In Kearny's experiments on hasty shelter construction, the usual material of construction for the roof was green hardwood poles. In the case of the pole shelter, poles about 4 to  $4\frac{1}{2}$  in. in diameter were used. Little handbook information is available on ultimate strengths of this material at high strain rates.

Stress-strain tests were made on selected 2-in. hardwood poles. Four-point loading was used, with the end supports 36 in. apart and the two symmetrical center points 8 in. apart. The test setup is shown in Fig. 13.10.

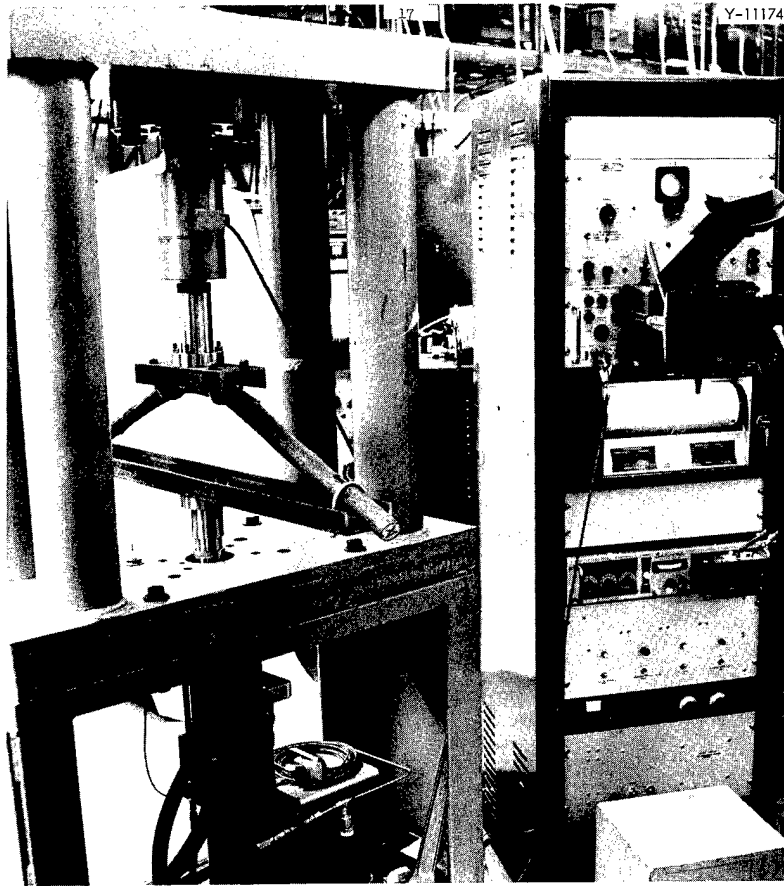
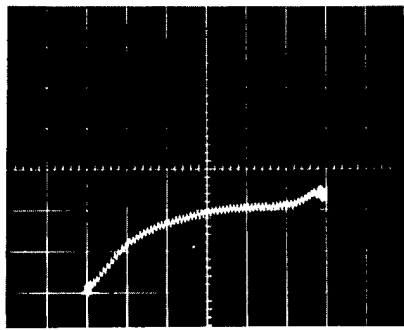
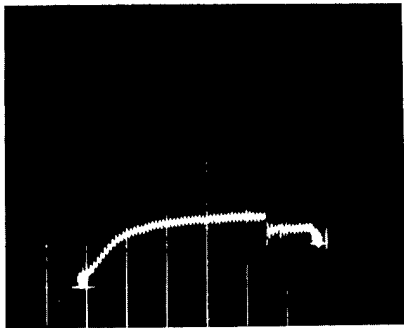

Fig. 13.10. Test setup for strength of green poles.

PHOTO 0820-72



DRY HICKORY 1.67-in. DIAM MIDSPAN



GREEN MAPLE 1.72-in. DIAM MIDSPAN

1 DIVISION HORIZONTALLY = 1 in. DEFLECTION  
1 DIVISION VERTICALLY = 500 lb.

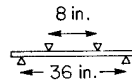

Fig. 13.11. Stress-strain curves for hardwood poles.

The machine available produced a deflection of 6 in. in 1.2 sec. These conditions were selected to approximate the strain and strain rate expected in pole roofs with a 3-ft earth cover from overpressures from the detonation of strategic nuclear weapons.

Stress-strain curves for green maple and dry hickory are shown in Fig. 13.11. The maple failed at  $4\frac{1}{2}$ -in

deflection. The hickory did not fail, although it acquired a permanent bend. The ripple in the curves is 60-cycle pickup in the amplifiers, which permits accurate computation of strain rate. The results of the tests are summarized in Table 13.1.

The ultimate fiber stresses exceeded 8000 psi for all samples, four times the handbook value for working stresses for dimension lumber from hardwood. This enhancement of strength is due in part to the fact that even boards with very straight grain have some fibers cut when ripped from logs. In poles, or logs, all fibers are continuous, even around knots.

More extensive tests at much greater strains are reported in Table 13.2. The measured strains up to the elastic limit were erroneously large due to crushing of the bark at the supports. However, this source of error disappeared in the plastic region of the curve. The ratio of ultimate deflection to elastic limit was calculated using an estimate of the elastic strain from the observed elastic limit stress and the indicated handbook values of the elastic modulus.

### 13.4.2 Dynamic Response of a Pole Roof

Techniques for the computation of the response of elastic-plastic structural members to blast loading have been well developed for many years. The one used here is that of Newmark, as presented in Appendix B of the Air Force Design Manual, "Principles and Practices for Design of Hardened Structures" (AFSWC-TDR-62-138).<sup>6</sup>

Figure 13.12 is a reproduction from that report of the graphical results of numerical solution of the mass-spring equation with an elastic-plastic spring. The abscissa is the duration of a triangular overpressure pulse in terms of the natural period of vibration of the roof. The duration of the overpressure may be read from Fig. 13.7 for an open shelter and Fig. 13.13 for a

Table 13.1. Mechanical properties of green hardwood poles at high strain rates<sup>a</sup>

Sample	Species	Midspan diam (in.)	Elastic limit		Elastic modulus (psi)	Ultimate	
			Stress (psi)	Strain		Stress (psi)	Strain
					$\times 10^6$		
1	Chestnut oak	1.97	8,000	0.00915	0.88	12,000	>0.054
2	Black oak	2.00	8,000	0.00927	0.86	Not observed	
3	Hickory	1.76	10,700	0.00612	0.96	Not observed	
4	Hickory (dry)	1.67	10,700	0.00716	1.37	>15,250	>0.043
5	Maple	1.72	8,350	0.00599	1.40	11,000	0.030
6	Maple (dry)	2.04	8,350	0.00803	1.05	11,700	Not observed

<sup>a</sup>Strain rates average 0.03/sec.

ORNL-DWG. 72-3691

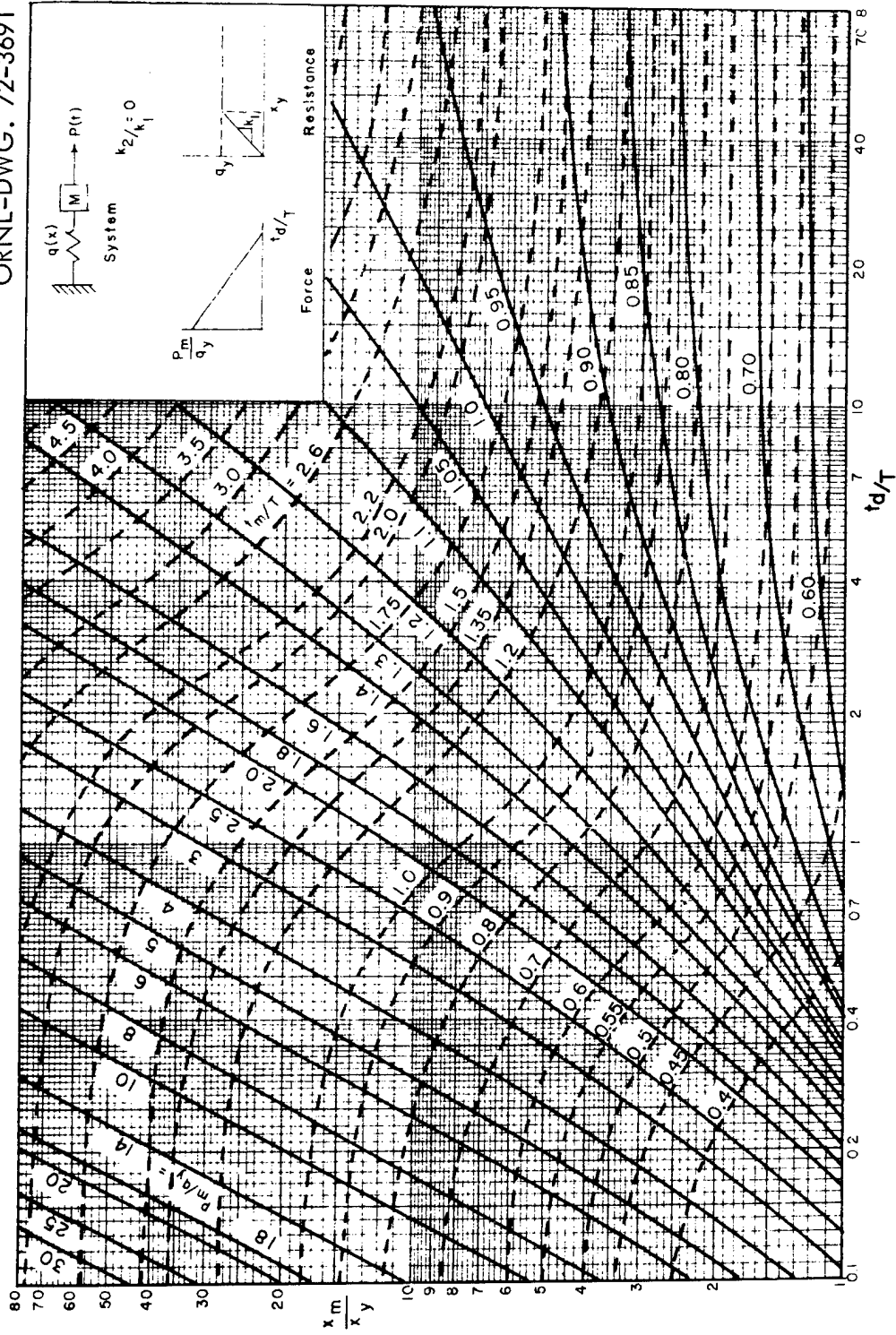

Fig. 13.12. Maximum response of simple spring-mass system to initially peaked triangular force pulse.

Table 13.2. Some ultimate mechanical properties of green poles

Species	No. tested	Fiber stress at elastic limit (psi)	Maximum load		Assumed elastic modulus (psi)	Ultimate deflection
			Elastic limit load			Elastic limit
					$\times 10^6$	
Loblolly pine	3	5,530 ± 917	1.109 ± 0.042		1.0	9.66 ± 1.00
Chestnut oak	2	10,150 ± 310	1.126 ± 0.016		1.2	3.33 ± 0.17
Black oak	5	8,380 ± 1,012	1.177 ± 0.056		1.2	8.85 ± 2.36
White oak	5	9,230 ± 2,207	1.198 ± 0.093		1.5	20.93 ± 7.33
Hickory	5	10,282 ± 690	1.165 ± 0.061		1.8	18.97 ± 2.77
Hickory (dry)	2	11,200 ± 150	1.200 ± 0.048		1.8	11.91 ± 1.44
Maple	2	8,300 ± 20	1.261 ± 0.040		1.5	11.76 ± 0.43
Maple (dry)	2	12,235 ± 1,465	1.148 ± 0.040		1.5	3.00 ± 0.58

Variation indicated is one standard deviation.

Nominal 2-in.-diam poles.

Four-point loading: 1.75 in. between center supports, 10.5 in. between end supports deflected 6 in. in 1.2 sec.

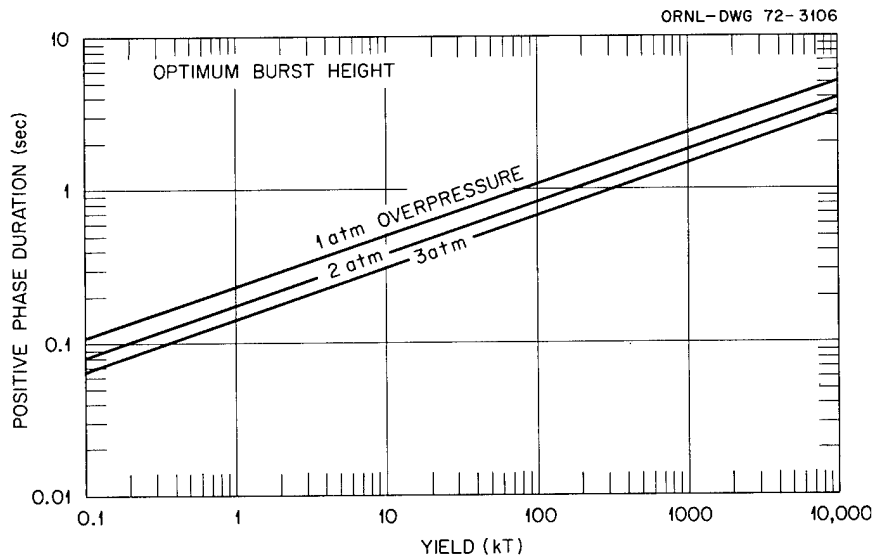

Fig. 13.13. Overpressure duration for optimum burst height.

closed shelter. The period of the roof may be determined from the handbook formula for a simply supported, uniformly loaded beam:<sup>7</sup>

$$T = \frac{l^2}{31} \sqrt{\frac{W}{EI}}$$

where

$T$  = natural period of vibration, sec,

$l$  = unsupported span,

$W$  = load/unit length,

$E$  = modulus of elasticity of beam,

$I$  = moment of inertia of beam =  $\pi D^4/64$  for pole of diameter  $D$ .

For a 4-in. pole,  $I = 12.56 \text{ in.}^4$  For  $l$  of 72 in.,  $E = 1.2 \times 10^6$ ,  $W = 600 \text{ lb}/72 \text{ in.}$ , then  $T = 0.125 \text{ sec}$ .

If we assume that the maximum strain is six times the yield strain, then the ratio of the transient peak pressure to the yield pressure can be read from Fig. 13.12.

For example, if we pick a model of the pole shelter with  $V/A$  of 110 ft, entrance coefficient of 0.6, sound speed of 1100 ft/sec, and a yield stress corresponding to 15 psi, one can determine the dynamic pressure the roof will survive for overpressures from different weapon sizes.

The results are plotted in Fig. 13.14. The open shelter will survive 50 to 60% more pressure than the closed

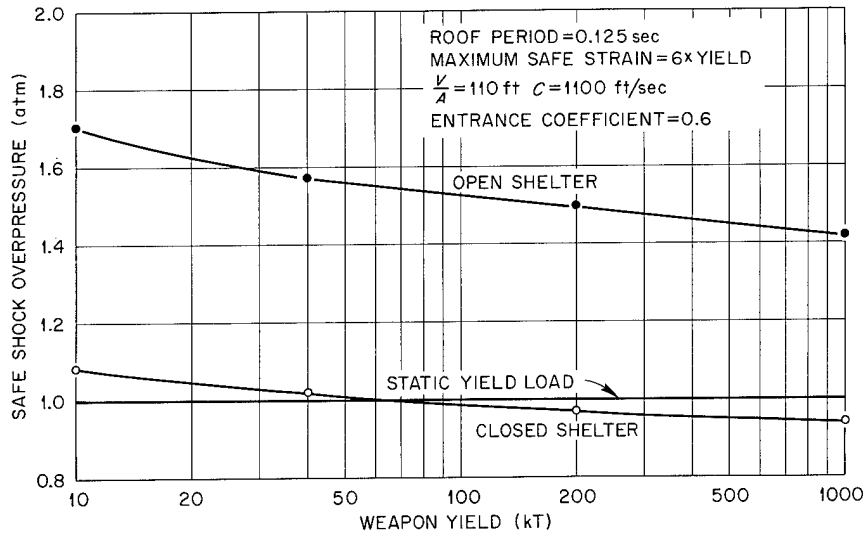

Fig. 13.14. Weapon yield vs shock overpressure.

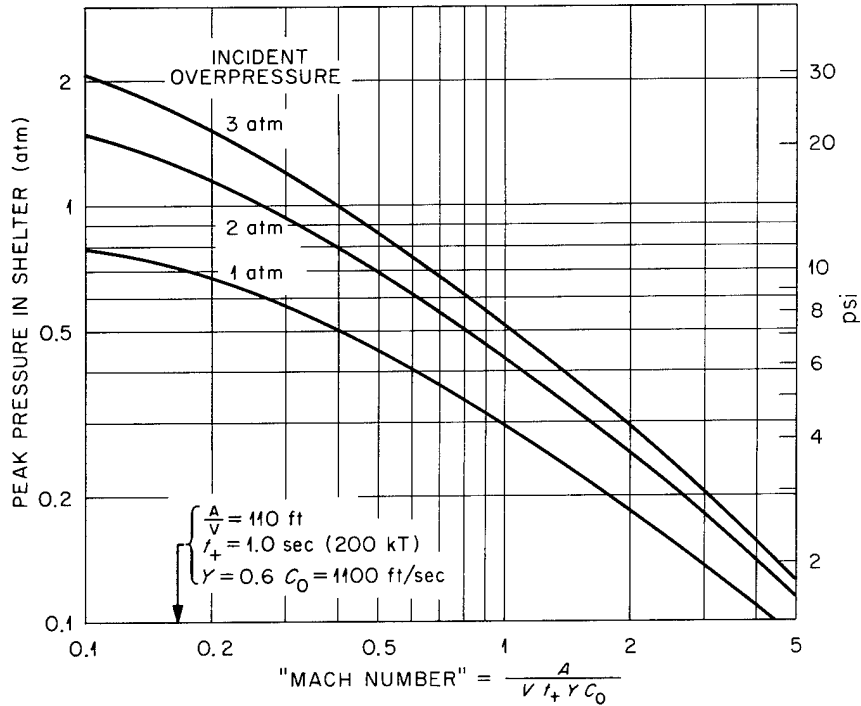

Fig. 13.15. Peak pressure in shelter vs Mach No.

shelter. This is not to be construed as a recommendation of open shelters if the means are at hand to close the entranceways. This same increase in strength could be obtained by using 5-in. logs instead of 4-in. logs on the roof of a closed shelter.

### 13.5 SOME CONSIDERATIONS ON DOORS

The hazard to the occupants of an open shelter from the pressure, missiles, and possibly contaminated or superheated dust more than offsets any slight increase in survival probability from the increased hardness of the roof of an open shelter. Even a leaky crude door assembled from logs will provide a great deal of protection to the shelter occupants from missiles and overpressure (provided, of course, the door frame is designed to take the load so the door itself doesn't become a missile). The overpressure to which shelter occupants are exposed through a leaky door may be estimated from Fig. 13.15, in which peak inside pressure is plotted against Mach number. The estimated area of the leaks in the door is used instead of the area of the entrance in the computation of Mach number. For example, if we close the 4-ft<sup>2</sup> entrance of a 440-ft<sup>3</sup> shelter exposed to 15-psi overpressure from a 200-kiloton weapon with a door of 5% open area, the Mach number increases from 0.166 to 3.33. This reduces the maximum overpressure inside from 10 to 2 psi. The rise time of the pressure (Fig. 13.7) is increased from 0.17 to 0.68 sec, which is as important as its magnitude.

The more difficult design and construction problem of restraining the door against the negative phase need not be solved for protection from at least one blast. The

door can fly open or fly away during the negative phase without any hazard to the occupants.

If the door must be kept open for ventilation, it can be closed manually in the several seconds between the flash and the arrival of the shock by an alert occupant assigned to the duty. Alternatively, it can be closed by gravity if held open by a strip of fabric that will be ignited by the flash.

### REFERENCES

1. N. I. Akimov (ed.), "Civil Defense," Moscow 1969, Translation in ORNL-tr-2306, 1971.
2. C. H. Kearny, "Hasty Shelter Construction Studies," Chap. 21 of *Annual Progress Report, Civil Defense Research Project, March 1970-March 1971*, ORNL-4679.
3. S. Glasstone (ed.), "Effects of Nuclear Weapons," U.S. Atomic Energy Commission, 1962.
4. H. L. Brode, "Theoretical Description of the Blast and Fireball for a Sea-Level Megaton Explosion" (U), RM-2248, RAND Corp., 1959. SECRET-RD.
5. R. W. Hillendahl, "Theoretical Models for Nuclear Fireballs" (U), LMSC-Boo6750, Lockheed Missiles & Space Corp., Sunnyvale, California, June 1966. SECRET-RD.
6. N. M. Newmark and J. D. Haltiwanger, "Air Force Design Manual. Principles and Practices for Design of Hardened Structures," AFSWC-TDR-62-138, Air Force Special Weapons Center, Kirtland AFB, N.M. (1962).
7. C. Carmichel, "Kents Mechanical Engineers Handbook" (12th ed.), Design and Production, p. 9-03, Wiley, N.Y., 1965.

## 14. Construction of Hasty Winter Shelters

C. H. Kearny

### 14.1. THE NEED FOR PROVENLY PRACTICAL HASTY WINTER SHELTER DESIGNS AND BUILDING INSTRUCTIONS

Although it appears unlikely that a nuclear power would intentionally choose the winter to press confrontation to such a point that either side would have to build winter shelters, there is nothing to prevent a crisis from escalating out of control at any season of the year. If such a wintertime crisis should involve the United States, our situation would be improved if both the U.S. military and civilian populations were able to build good hasty winter shelters where needed.

In this report the term "hasty winter shelters" means shelters that can be built within 48 hr or less, in ground frozen to a depth that makes ordinary excavation of below-ground hasty shelters impractical and/or necessitates the making of above-ground hasty shelters covered with snow.

The writer could find no records of any hasty winter shelters having been built in the United States. Therefore, he was guided primarily by Russian translations\* and the experience of Americans who live in the Colorado Rockies.

### 14.2. OBJECTIVES

The objectives of the 1972 winter shelter-building experiments were:

1. To investigate the practicality of Russian designs of both above- and below-ground hasty winter shelters;
2. To determine the designs of hasty and expedient winter shelters that are most practical for Americans to build, using widely available materials and equipment.

---

\*Mainly one illustrated article: "Winter Shelters," by F. Ostroukh, in *Voyennyye Znaniya*, February 1971, Moscow.

### 14.3. SCOPE OF THESE CONSTRUCTION STUDIES

Due to limited time, manpower, and funds, the shelters built in February and March 1972 were constructed solely by an independent contractor, who employed men experienced in working in extremely cold weather. During these two months the temperatures were unusually mild for the location selected — a site at an elevation of approximately 8500 ft near Grand Junction, Colorado. The lowest temperature was only  $-7^{\circ}\text{F}$ . However, many Americans living in cold parts of the United States do not have adequately protective footgear to enable them to work outdoors for many hours in the snow at temperatures around zero. Thus, we cannot assume from these shelter-building experiments that average Americans, especially Americans from big northern cities, could build good hasty winter shelters for themselves under the conditions likely to prevail if an extreme crisis should develop during the dead of winter.

Since the area chosen for the shelters is, for the most part, wooded, with such trees as aspen, ponderosa pine, and scrub oak predominating, enough straight poles and logs were available for the cutting near the building sites.

### 14.4. ABOVE-GROUND HASTY WINTER SHELTERS COVERED WITH SNOW

#### 14.4.1 Log-Tepee Shelter

As illustrated and described in Figs. 14.1, 14.2, and 14.3, this shelter is a strengthened version of the "Conical Shelter-Hut Constructed of Snow and Poles," described in F. Ostroukh's article, "Winter Shelters."\*

---

\*F. Ostroukh, op. cit.

PHOTO 0465-72

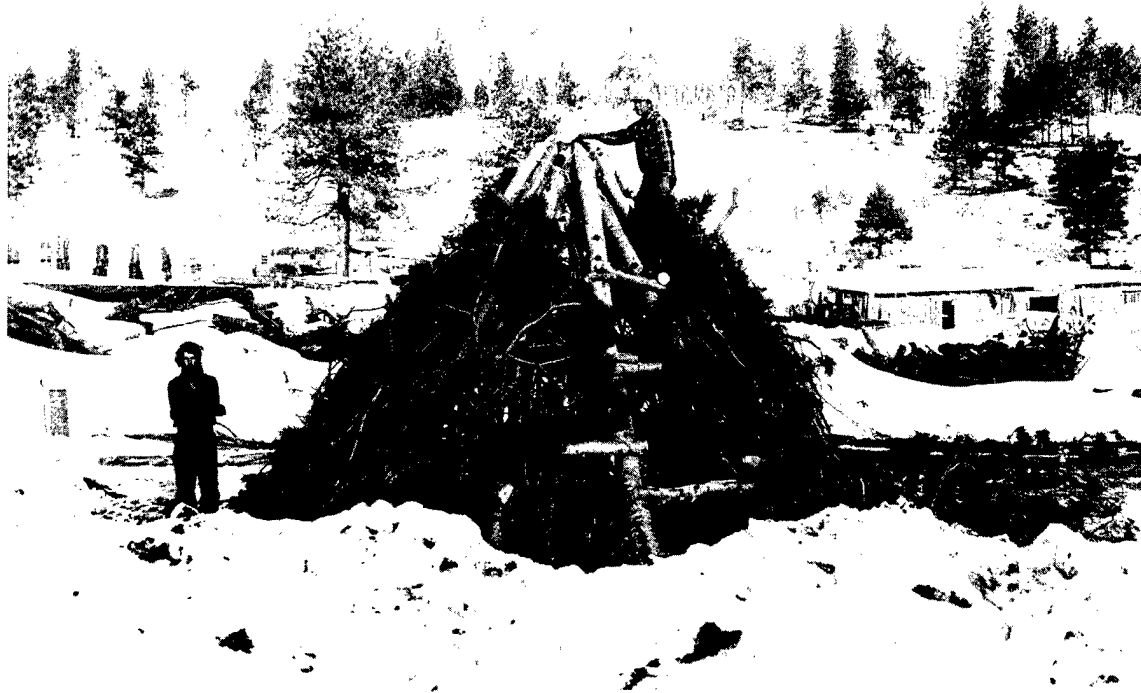

Fig. 14.1. Log-Tepee Shelter built according to modified Russian specifications and dimensions given in an article by F. Ostroukh: "Winter Shelters," in *Voyennyye Znaniya*, No. 2, February 1971, Moscow. Twelve logs, each 17 ft long and with 6- to 10-in.-diam tops, were tied together around their tops with approximately 200 ft of  $\frac{1}{4}$ -in. nylon cord. Later, the covering of pine limbs (over the wired-on short horizontal poles) was completed, except for the entryway opening, in which a man is seen squatting.

PHOTO 0478-72



Fig. 14.2. A 26,000-lb D6 bulldozer pushed snow from one side (where snow dampened from a hillside seep enabled the operator to build a snow ramp) over the top to the dry-snow side of the Log-Tepee Shelter without damaging it. The snow was finally raised on all sides almost to the top of the ventilator directly in front of the bulldozer blade. Below the ventilator is the last uncovered part of the 6-mil polyethylene covering, with which it was found necessary to cover the Russian-specified "brushwood" in order to keep dry, sugary, free-running Colorado snow from running through the pine boughs into the shelter.



Fig. 14.3. View inside the 20-ft-diam Log-Tepee Shelter, showing three tiers of small short logs wired to the outsides of two of the twelve 17-ft main logs. The outer pine limbs were covered with 6-mil polyethylene. This shelter, large enough for at least 30 men, was built in 2.6 man-hours per occupant space. This time included the 2.7 hours it took the bulldozer to cover this 13 $\frac{1}{2}$ -ft shelter with snow, as well as the time for its intermittent use to drag all materials to the site and to help raise the log tepee.

To reduce the possibility of this unusual type of large shelter collapsing while snow was being bulldozed onto it, I specified the use of 12 "teepee" logs, each 17 ft long and with tops 6 to 10 in. in diameter, and the equal spacing of their butts around a circle of 10 ft radius. The Russian article specified 20 poles, with their butts placed on the circumference of a circle having a radius of 3 m, but does not give the lengths or diameters of the poles.

#### 14.4.2 Ridgepole Shelter

The captions of Figs. 14.4, 14.5, and 14.6 summarize the main advantages and disadvantages of this Russian shelter. We concluded that a Ridgepole Shelter generally is not as practical as an A-Frame Log Shelter, except possibly for persons having no saw to cut the upper ends of sidewall logs at 45°.

#### 14.4.3 A-Frame Log Shelter

A shelter of this design is strong, easy to build if small logs are available, and capable of being built in open

areas either above or below ground level (see Figs. 14.7, 14.8, and 14.9). Therefore, an A-Frame Shelter is generally more useful than a Ridgepole Shelter.

The 10-man A-Frame Log Shelter required 4.8 man-hours per shelter space, vs 3.0 man-hours per space for the Ridgepole Shelter. However, most of this difference in man-hours was because the bulldozer was used only to cover the A-Frame Log Shelter with snow, whereas for building the Ridgepole Shelter the bulldozer also cleared the site and dragged all the logs and branches to it.

### 14.5. BELOW-GROUND HASTY WINTER SHELTERS

#### 14.5.1 Breaking Through Frozen Earth

**By hand.** To determine the fastest method of removing a thick layer of hard-frozen earth as the start for digging a trench or a shelter-entry shaft, some experienced rural Colorado citizens and I used various combinations of common hand tools. We concluded that, except in very rocky frozen soils, the combination



Fig. 14.4. A Russian Ridgepole Shelter, with its ridgepole resting on two logs, each wired to the tall green stumps of two fresh-cut trees 15 ft apart. All the wall poles were wired to the ridgepole and their butts were secured in two "V" trenches, each 15 ft long and about 4 in. deep. These very shallow trenches required 2½ man-hours to dig into the frozen ground with a pick. As an added strengthening, two 6½-ft-long, 8-in.-diam posts were positioned at 5-ft intervals under the ridgepole.



Fig. 4.5. Placing ponderosa pine boughs on one side of the Ridgepole Shelter. Bare aspen limbs were placed on the other side. Both brush coverings served equally well when 6-mil polyethylene was used to cover the brush, before snow was bulldozed over the whole shelter. The rectangular connecting shelter ( $3\frac{1}{2} \times 4\frac{1}{2}$  ft inside, and 16 ft long) is a small version of a Russian Pole Shelter, which when completed is held together by earth or snow pressure. This small shelter later had a snow-tunnel entranceway, with a 45-degree turn.



Fig. 14.6. South side of the snow-covered Ridgepole Shelter pictured after a week of spring thaw had melted about 3 ft of snow off the south-facing slope. This shelter was covered with trashy, dirty snow, because the two trees that were topped to produce the supporting stumps were in the edge of a wooded area. Hence the bulldozer in a couple of hours could not collect enough snow to cover the top of either shelter with more than about 2 ft of snow. Counting the austere capacity of these two connected shelters as 23 men, mechanized construction required 3.0 man-hours per space.



Fig. 14.7. A-Frame Log Shelter, with 45-degree sloping sides of green aspen logs, each 9 ft long, with their tops at least  $4\frac{1}{2}$  in. in diameter and nailed to the 12-ft-long,  $2 \times 8$  in. ridgeboard. The butts of the 9-ft wall logs rest on the frozen ground; outward horizontal movement of the butts of the wall logs is prevented on the two sides by two 10-ft base logs. The ends of the two base logs are held in place by being fitted into deep notches cut into two 14-ft end logs. This rectangular log frame on the ground eliminates the need for time-consuming digging into frozen ground. All logs were dragged by the men through  $2\frac{1}{2}$ -ft-deep snow an average distance of about 200 ft from where the trees were felled.



Fig. 14.8. A-Frame Log Shelter being covered with snow, after having been covered with 6-mil polyethylene. This thin plastic film kept dry free-running snow from flowing through the cracks between the logs, and prevented melted snow from dripping inside. Note the ventilation duct made of four  $1 \times 8$  in. boards, 8 ft long, and connected to shelter just below its top, beside its ridgeboard. The final snow covering came within 2 ft of the top of this board duct.



Fig. 14.9. View from inside the A-Frame Log Shelter, looking out into its entryway, a 9-ft-long snow tunnel with a 90-degree turn. This entryway has another 4 ft of snow tunnel, not shown. In the foreground is seen an end log of the rectangular log frame, with the butts of the almost vertical end-wall logs pressing against it. Outside the end-wall logs is the 6-mil polyethylene covering, which kept the bulldozer-compacted snow from entering. Snow arching, and not the strength of the polyethylene, withstood most of the pressure of the snow. To build this 10-man shelter, with all work except the snow covering done by hand, required 4.8 man-hours per space.

of an ax, a heavy digging bar, and a shovel is best, if used as follows: first, hit straight downward with the ax (or, second best, with the ax-like blade of a pick-mattock) to cut a set of parallel grooves in the earth, about 8 in. apart. Next, perpendicular to these parallel grooves, cut a second similar set. Then with the steel bar strike hard, hitting near the base of an 8 X 8 in.<sup>2</sup> chunk of frozen earth, to knock this chunk loose. In this manner, knock loose and remove all the 8-in.<sup>2</sup> chunks in a layer approximately 4 in. thick; then repeat this procedure through the frozen earth layer.

Even this method of cutting and knocking chunks out of frozen earth is slow, hard work; an energetic strong youth, working about as hard as he was able, took 2 hr to dig through 12 to 14 in. of unplowed, clayey, hard-frozen loam, excavating a pit measuring only 2 by 4 ft across.

**By machine. Backhoes.** According to construction foremen I questioned (men with years of backhoe experience in the Rocky Mountains), when the "frost" is from 6 to 12 in. deep in the ground, an ordinary-sized backhoe takes about twice as long to dig a trench as the same backhoe does when the ground is unfrozen. If the frost extends deeper than about a foot below the surface, these men said that it is not worthwhile to try to use a backhoe for normal peacetime excavating.

**Bulldozers.** Most bulldozers, unless equipped with special rippers, excavate extremely inefficiently in ground frozen more than a foot deep.

**A bulldozer with a ripper.** As described in Fig. 14.10, a bulldozer with a movable, detachable ripper on its blade is capable of excavating, layer by layer, earth frozen many feet deep, as well as some softer rock foundations.

**With explosives.** The Russian statement (in the aforementioned article on winter shelters) that 20 to 60 kg (44 to 132 lb) of ammonite detonated on the surface is needed to break through ground frozen 2 ft thick in order to facilitate the excavation of a 20-man trench shelter appears to be somewhat optimistic. Perhaps the Russian writers assumed that anyone using explosives on the surface would cover the charges with logs, or otherwise direct more of the explosive force downward. I found that 43 lb of 60% dynamite, detonated on the surface of hard ground frozen only about 6 in. down, blew a crater only 15 in. deep and 4 ft across.

Explosives are more effective when detonated within a frozen layer of earth, but less so than in many softer rock formations. For example, in order to break a 22-in.-thick surface layer of hard-frozen clayey soil, we found that it was necessary to explode three ½-lb sticks of 60% dynamite, all three detonated in a 1¼-in.-diam

hole. This 1½-lb charge broke a hole only 12 to 15 in. in diameter. Thus, to facilitate digging even a modest-sized trench shelter in deep-frozen ground, it is necessary to use many pounds of dynamite or equivalent explosive.

If sufficient explosives are available, the main problem is how to get them efficiently placed within the frozen ground. Of the several methods tested to enable persons lacking mechanized drills to place explosives efficiently in frozen ground, the following method was by far the most practical: drive holes into the tough frozen ground by hitting a sharpened solid steel rod (or a sharpened piece of pipe) with a heavy sledge hammer. The best widely available solid steel rods can be obtained from truck axles. In a few minutes, a welder can shape one end of a truck axle into a roughly conical point and cut the plate off the other end, so that the danger of pieces of this hard steel plate breaking loose and hitting workers is eliminated.

When driving a sharpened rod or pipe into frozen earth, after driving it downward a few inches, hit it several times on its sides, in different directions, in order to keep it loose in the hole. If two men are available for driving holes for explosives and if a large Stilson wrench is also on hand, the rod or pipe should be turned intermittently with the wrench as it is driven downward.

#### 14.5.2 Narrow Covered-Trench Shelters

**One-meter-wide log-covered trench shelter.** Following a Russian description and drawing, we attempted to make such a shelter in a trench 6 ft deep, 10 ft long, and only about 1 m wide. First, a D6 bulldozer with a ripper on its blade broke out the 8 to 10 in. of frozen earth, sometimes in massive slabs with outer edges a couple of feet beyond a planned side of the trench. Thus, the upper part of the trench was 1 to 2 m wide. This resulted in a trench of very unequal width. Below about 1 ft, all digging was done by pick and shovel. Because massive slabs of rock were encountered at around 4½ ft, this shelter was not completed as a narrow Russian shelter with a single bench on one side and a narrow board-bunk overhead. It was finished as a stoop-in unfurnished trench shelter.

For the roofing material, workers dragged 8-ft logs (minimum diameter 5 in.) several hundred feet from where the aspen trees were cut in the nearest forested area. Cutting and hand dragging all logs through a couple of feet of soft snow took 12 man-hours of hard work. This included shoveling approximately 2 ft of partly frozen earth onto the log roof. Because of the



Fig. 14.10. Ripper attached to the blade of a D6 bulldozer, which enables a bulldozer to excavate deep-frozen earth and some softer sedimentary rock — materials that most bulldozers without rippers cannot excavate. Unfortunately for winter hasty shelter construction prospects, few bulldozers have rippers, and in most communities the available explosives with which to blast through deep-frozen earth are also in short supply.

dryness of this part of Colorado and the probability that the numerous rocks and rough chunks of frozen earth would puncture any rainproofing "buried roof" made of polyethylene, we put on an earth cover without any attempt to rainproof it.

To complete this shelter required 28 man-hours, plus 15 min of bulldozer-ripper time. If this 10-ft-long shallow trench shelter is rated as having five very austere spaces, then 5.6 man-hours per space were required.

**Wire-catenary roofed shelter.** Following another Russian design (as regards width and depth of trench) for a narrow trench shelter dug through frozen ground, we tried to make a trench 1.8 m wide. First, we used the bulldozer with its ripper. Due to the same problem of irregular, large frozen chunks breaking out, some parts of this 16-ft-long trench were as wide as 2.3 m. Furthermore, we again hit such rocky digging, at about 5 ft below the surface, that we abandoned the plan for building a shelter having benches with overhead bunks on each side.

Our recurrent difficulties in hitting rocks and being unable to dig shelters to the desired depths stemmed from being in an area where none of us knew the subsurface conditions. This situation illustrates why people, who may be building hasty winter shelters in areas where the ground is frozen and/or the subsurface conditions are unknown to them, should learn how to build above-ground snow-covered shelters. Such snow-covered shelters can almost always be completed as planned within a few hours of beginning work, and the Russians' claim that their snow-covered above-ground shelters have protection factors of 50 to 80\* appears to be factual. Then, if time permits, it would be prudent to follow the Russian advice, and also to laboriously construct below-ground shelters at the same site, with protection factors of 200 to 1000.

To provide approximately 6 in. more headroom in this too-shallow trench shelter, I had the wire-catenary roof frame placed on pairs of logs, wired together, with a pair on each side of the trench. This turned out to be a more laborious chore than anticipated and was not worth the effort.

To build this shelter, except for shoveling the earth onto its wire-catenary roof and building a small Kearny Air Pump, required 33 $\frac{1}{4}$  man-hours. If it had been finished, I estimate 46 man-hours would have been required. If rated in its unfurnished, too-shallow condition as an austere 6-man shelter, 7.7 man-hours per space produced would have been required.

---

\*F. Ostroukh, op. cit.

### 5.3 Wide, Bulldozed, Log-Covered Shelter

Preliminary investigation, covering both military and civilian experiments in building different types of hasty or expedient shelters, revealed no record of a log-covered trench shelter having been built in the United States, using a trench as wide as those dug by standard bulldozers. Considering the availability of bulldozers, the rapidity with which they can excavate wide trenches about 7 ft deep in most areas, and the availability in many parts of the United States of logs long enough to cover trenches about 14 ft wide, one may conclude that perfected plans for building large shelters of this type should be developed.

An interior view of this 450 ft<sup>2</sup> trench shelter is shown in Fig. 14.11. The caption summarizes some of its advantages, which center around the fact that a few properly mechanized workers could build hasty shelter spaces for many people within a few days, especially if they were to build a simpler type than this prototype of a 14-ft-wide trench shelter. The simpler type would be a shelter with its 22-ft roofing logs laid side by side, touching each other.

The design and construction details of this and other large hasty shelters, which of course can be built in less time if construction is not slowed by snow and frozen ground, will be covered in a forthcoming ORNL Technical Memorandum.

### 14.6. HABITABILITY OF WINTER SHELTERS

Although outside temperatures ranged from a low of -7°F to highs in the low 30's, inside the above-ground snow-covered shelters the temperatures remained below freezing throughout this shelter-building period in February and March. Inside temperatures varied from nighttime lows of around 23°F to afternoon highs of around 26°F. The humidities were decidedly high; matches left exposed became so damp within a couple of days that it was difficult or impossible to strike them.

As some of the snow (that covered the shelters and lay on the ground slopes above the level of the shelter floor) slowly thawed, thin sheets of seeping water flowed into the above-ground shelters and slowly froze in thin ice sheets on the shelter floors. The 6-mil polyethylene film covering the roofs prevented melted snow from dripping into the above-ground shelters. I was the only person testing the habitability of these winter shelters for more than one night. On occasion, I found it necessary to move my poncho and sleeping bag to another part of the floor. However, if these above-ground shelters had been fully occupied, the

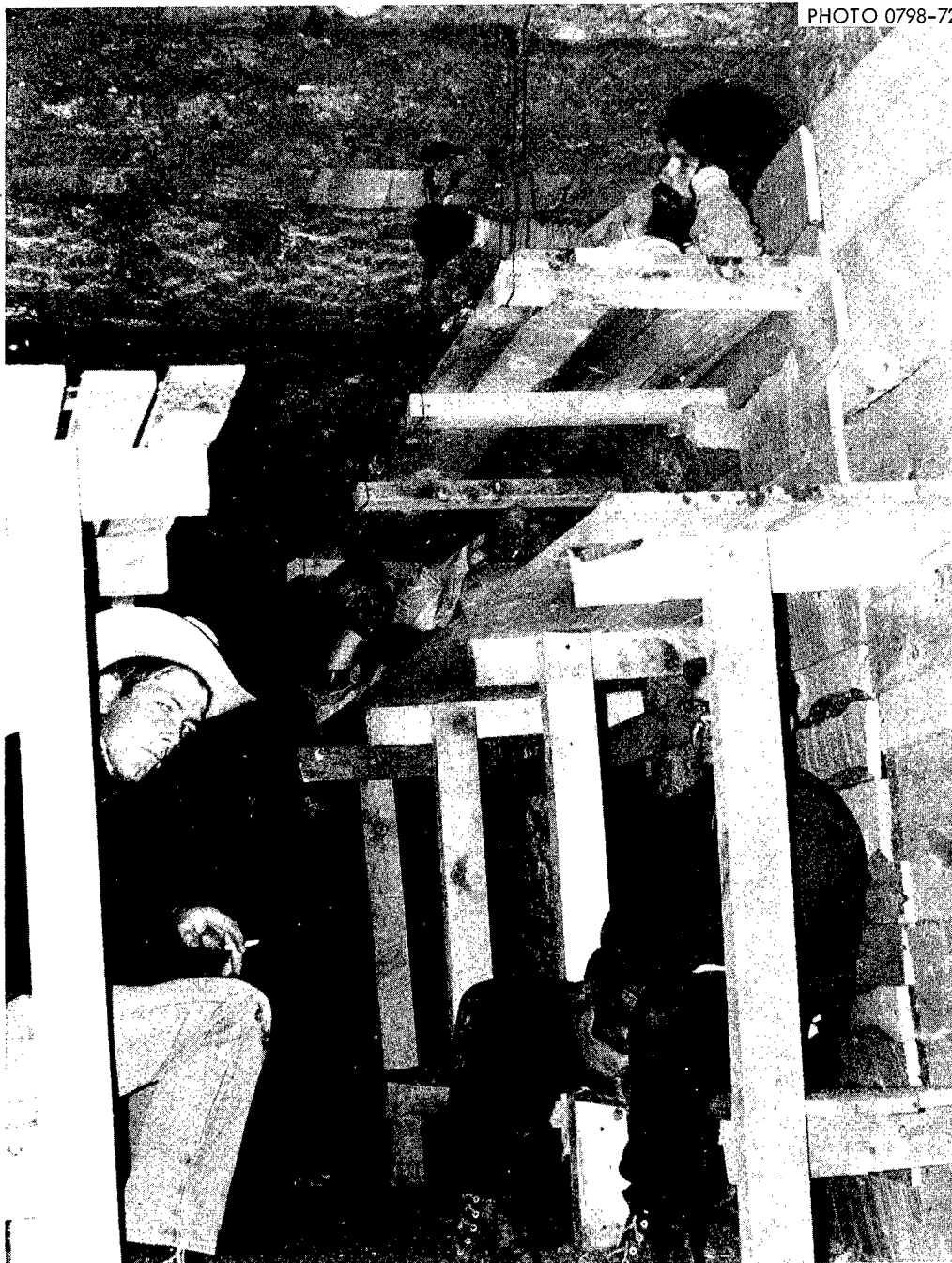

PHOTO 0798-72

Fig. 14.11. Benches and bunks inside a 7-ft-wide half-section of what is believed to be the first hasty fallout/blast shelter built in the U.S. in a bulldozed wide trench roofed with logs. A D6 bulldozer, using a ripper intermittently, required 8.1 hours to excavate a trench that was 14 ft wide, 7 ft deep, and had an almost flat bottom 34 ft long. In soft earth, this excavation could probably have been finished in about 2 hr. But the partly frozen top 6 in. of soil, and especially the  $6\frac{1}{2}$  ft of thin-bedded sandstones and very tough shales, made bulldozing slow work. The total man-hours required to complete this shelter with two entryways, 4 ft of compacted earth covering, and 450 ft<sup>2</sup> of bare floor space, was 129 $\frac{1}{2}$  man-hours. If it were rated as a 45-man shelter and were equipped with a homemade Kearny Air Pump for ventilation-cooling, 3.0 man-hours per space would have been required. If completely equipped with board benches and "hot" bunks for 60 occupants, and if all its side walls had been covered with boards, the estimated man-hours per space would have been about 4.2. But this slow interior work could be done after all 60 occupants were protected inside the shelter.

occupants would have been in decidedly serious difficulties unless they had made provisions for keeping all of them from being wetted by snow-melt water. This could be done by placing poles, spruce or pine boughs, or other brush on the floor so that entering water could flow under the bedding of shelter occupants.

As I anticipated, insensible perspiration from my body within a couple of days dampened my down-filled sleeping bag, especially on its lower side where it rested against a 1-in.-thick foam pad. To simulate the probable actions of a person inexperienced in sleeping on the ground in cold weather, I did not provide for air circulation under my bedding.

Russian descriptions\* of winter shelter construction stress the importance of insulating the shelter ceiling and walls and state that: "In just 1-2 hours after a sunken winter shelter is fully occupied, the temperature will climb to above freezing." However, at the very low air velocities that prevail even in a well-ventilated winter shelter (in which 1 cfm of outside air per shelter occupant is sufficient to prevent a harmful concentration of respiratory carbon dioxide from building up), shelter occupants with good winter clothing and a few blankets can live comfortably at temperatures a few degrees *below* freezing, provided they can keep their clothing and bedding from getting very damp.

In contrast, if the shelter temperatures are maintained even a few degrees *above* freezing, then in most winter shelters the melting of snow and frozen earth will result in water dripping on the occupants, the floor getting muddy and wet, and the air humidity rising. Therefore, practical tests of winter shelter habitability should include both (1) insulating shelter ceilings and walls in the manner described in this Russian article, thereby maintaining shelter temperatures slightly above freezing, and (2) also maintaining shelter temperatures slightly colder than freezing. In subfreezing weather, temperatures inside the shelter could be kept below freezing either by pumping sufficient outside air through the shelter with a small Kearny Air Pump or by improvising "ducts" in the shelter opening to produce a sufficient convective flow of air through the shelter.

Practical shelter habitability tests should also involve the design and operation of expedient stoves, of types that can be used to efficiently dry shelter occupants' clothing and bedding with minimum fuel consumption, and also to cook.

#### 14.7. CONCLUSIONS

1. The Russian instructions for building winter shelters (both above-ground snow-covered shelters and

below-ground shelters dug through frozen earth) appear to be based on winter field tests and are practical.

2. Most able-bodied Americans, if given good shelter-building instructions and if they have adequate cold weather footwear and clothing, should be able to build for themselves good hasty (or expedient) winter shelters within a few days, if blizzard conditions do not prevail.

3. If adequate mechanized equipment is available, large above- or below-ground shelters should be built, since such large shelters require fewer man-hours of work per shelter space constructed than small shelters.

#### 14.8. RECOMMENDATIONS

1. The step-by-step illustrated shelter-building instructions, based on these 1972 initial experiments in building winter shelters, should be improved by having more typical groups of Americans (both military and civilian) build these and other hasty winter shelters under a variety of conditions. Priority should be given to perfecting practical designs for winter shelters that require little or no mechanized equipment to build and cover.

2. Since apparently no information is available regarding the blast protection afforded by stout log shelters covered with gently sloping large mounds of compacted snow, blast tests of such above-ground winter shelters are indicated. Likewise, the resistance of covered trenches with their sides not shored, but with the uppermost foot or two of their earthen sides frozen hard, should be determined by blast tests. Also, the blast resistance of snow-tunnel shelters (dug in large mounds of compacted snow and only 2 to 3 ft wide) should be determined, as should the strength of narrow tunnel-type shelters dug by hand beneath 1 to 3 ft of frozen surface soil.

3. Realistic shelter habitability tests of a variety of winter shelters should be conducted, with shelter temperatures maintained both a few degrees below and a few degrees above freezing. Forced ventilation with homemade Kearny Air Pumps, as well as with improvised ducts to facilitate convective ventilation-cooling of winter shelters, should be evaluated by tests of fully occupied shelters. Full occupancy should be tested both (1) on the American basis of 10 ft<sup>2</sup> of unfurnished floor space per occupant, and (2) on the Israeli-Russian basis of 1 m<sup>3</sup> (34 ft<sup>3</sup>) per occupant in furnished shelters. The possible desirability, under subzero conditions, of placing some insulation over frozen ceilings and walls should be investigated, as should the design of efficient improvised shelter stoves, primarily needed in cold damp shelters to dry out clothing and bedding.

\*F. Ostroukh, op. cit.

# 15. Blast Shelter Potential in New Government Buildings\*

George A. Cristy

## 15.1 INTRODUCTION

In previous studies,<sup>2,3</sup> we have shown that several courses of action are possible which could provide improved protection of the U.S. population at quite modest cost. For example, nearly 13 million of the 170 million fallout shelter spaces identified by the National Fallout Shelter Survey (NFSS) have an inherent capability for protection against initial effects of nuclear weapons because they are located in tunnels, basements of buildings of heavy masonry construction, unused ammunitions bunkers, etc. These shelters are designated PV (personal vulnerability) 71 and 81 on the NFSS listing. Providing emergency power and/or ventilation to certain of the located facilities would increase the available PV 71 and 81 spaces to nearly 20 million. Unfortunately, many of these shelter spaces are not being incorporated into community shelter plans and have not been marked and stocked because they are located in areas where large quantities of fallout shelter spaces have been found in the central core of the upper floors in tall buildings. Although the shelters in the tall buildings provide excellent protection against fallout if the building structure is not damaged, most of the buildings are extremely sensitive to damage by blast. Therefore the quality of protection for the citizens of many communities could be improved immediately or in the very near future merely by changing the priority and selection criteria for shelters. Increased improvement would also result, at slight additional expense, by providing Kearny pumps<sup>4</sup> or ventilation kits (PVK)<sup>5</sup> to all PV 71 and 81 shelter spaces needing ventilation.

Further improvement in the shelter posture could be obtained economically by the simple expedient of planning for some overcrowding of the PV 71 and 81 spaces for short-term stay, with subsequent (i.e., post attack) redistribution into undamaged aboveground shelters, as suggested earlier by Krupka<sup>6</sup> and by Harvey.<sup>7</sup> The proposal of 150% overcrowding is only

slightly more severe than the existing shelter criteria in many Western European countries, the space available in Soviet high-protection-factor expedient shelters,<sup>8</sup> or in the Israeli reinforced-concrete bunkers,<sup>9</sup> and should be quite feasible for two- or three-day occupancy if the necessary water and ventilation are provided. This would probably require some additional deployment of Kearny pumps and/or PVK ventilation kits to the PV 71 and 81 spaces which require enhanced ventilation, and it might even require Kearny pumps, or the equivalent, to augment the ventilation of spaces deemed adequately ventilated on the basis of the standard 10 sq ft per person. The maximum number of blast-resistant shelters that could be provided by these measures is estimated to be of the order of 50 million.

We have also shown<sup>3</sup> that blast slanting<sup>†</sup> of the construction of the various transportation systems, especially subways and freeways which are being rapidly expanded in and around our cities, could provide blast-resistant shelter spaces at modest incremental cost. Extrapolation from the data<sup>3</sup> on 43 of the Standard Metropolitan Statistical Areas (SMSA) suggests that another 10 to 15 million blast-resistant shelter spaces could be obtained if a decision were made to provide the funds necessary to make the minor modifications required before construction started. The overcrowding option might increase this to 25 million blast-resistant spaces.

These two sources of blast-resistant shelters (shelter criteria changes and blast slanting of transportation systems) could improve the U.S. civil defense posture by providing more than fallout protection in the urban areas where such protection is likely to be needed most. However, it is clear that even if both these suggested programs were undertaken immediately, including the overcrowding option, we would still have no more than 75 million blast-resistant shelters, far short of the

\*This is a condensation of the final report<sup>1</sup> on a study of the same title now being published.

<sup>†</sup>Blast slanting implies making design changes involving little or no extra cost, so that some protection against blast, and against other immediate effects, of nuclear weapons is obtained without loss of function for which the structure is being built.

implied goal of providing blast protection for all the urban population. Therefore, other sources are needed. One method of obtaining additional blast shelters which might be made available through governmental direction is to require blast slanting for the underground portions of buildings being designed and built for governmental agencies. This year a study was made to examine the potential of that approach.

## 15.2 GOALS AND ASSUMPTIONS

The primary goal of the study was to furnish an estimate of the amount of space in programmed federal buildings which is slantable for protection from direct effects of nuclear weapons. The Office of Civil Defense expects to use these data in its ongoing studies of possible future goals for sheltering populations under various degrees of risk. In this context, it was necessary to make certain assumptions about the milieu which was being studied. These assumptions are summarized below.

### 15.2.1 Priority of Marking and Stocking

It was assumed that all PV 71 and 81 (i.e., underground) shelters have been marked and stocked, that all PV 71 and 81 shelter spaces which needed ventilation for full utilization have been provided with Kearny pumps or PVK kits, and that all transportation systems and buildings for which U.S. government funds were provided, in whole or in part, have been designed to provide the maximum blast shelter space consistent with the peacetime functions without increasing significantly the overall cost of the construction.

### 15.2.2 Federal Building Program

It was assumed that the amount of money available for construction of federal buildings of all types would continue at the level of the last five years, that the types of buildings would continue unchanged, and that new buildings would continue to be built in locations relative to population centers comparable to the ones now in the process of construction.

### 15.2.3 Cost

It was assumed that the underground areas within federally financed buildings could be blast slanted and provide austere blast shelters at a cost of \$6 per sq ft (\$60 per shelter space). This cost was based on the results reported by the Stanford Research Institute (SRI) feasibility study<sup>10</sup> of blast slanting. Not all

federal buildings were checked specifically to determine whether they meet the SRI criteria for blast slanting at \$60 per shelter space. Spot checking a few buildings showed that the cost of blast slanting of some of the buildings may be twice that much because of the complex nature of the buildings, while some of them did meet the SRI criteria and could be slanted economically. A more detailed study would be required to determine whether the floor space usage of the buildings could be rearranged to allow the basement spaces to be more in line with economical slanting criteria. The optimistic assumption that all the buildings studied could be so redesigned is offset to some extent by the deletion from the list of some buildings with partially exposed basement space which also might be redesigned to provide unexposed basements.

### 15.2.4 Population to be Sheltered

It was assumed that the entire urban population in the U.S. in 1980, approximately 180 million, should have protection against initial effects of nuclear weapons consistent with survival at the 15-psi (free field) overpressure range.

## 15.3 DATA PROCESSING

The 1970 budget of the United States Government was examined to find what agencies had construction authorizations. By contacting representatives of the various agencies it was determined that only the GSA, VA, and AEC were in the process of designing and constructing buildings which could be considered feasible for blast slanting. The military construction was excluded on the basis that it would not be available to the general public because of national security restrictions. The Federal Prison System construction was excluded for a similar reason. Since typical airport facilities seldom include underground structures, no attempt was made to include FAA construction.

The three agencies (GSA, VA, and the AEC) made available design drawings and/or information on all buildings which are currently in the design or construction phases. From this information, the following data were extracted on each building:

1. Location of the project by state, county, city, and street address,
2. type of construction,
3. occupant usage,
4. gross and net square footage of basements, sub-basements, and tunnels,

5. number and size of windows or other outside openings located in basements,
6. estimated construction cost,
7. date of design completion (actual or estimated),
8. estimated date of completion of construction.

The location of each federal building (excluding those with no underground space) reported by GSA, VA, or AEC was plotted on U.S. Geological Survey (USGS) maps so that the Universal Transverse Mercator Grid (UTMG) coordinates, to the nearest kilometer, could be read off the maps. The National Locator Code<sup>11</sup> provided the eight-digit serial number of the Standard Location Area (SLA) in which the building is located. The 1970 census<sup>12</sup> was used to calculate a ratio of 1970 to 1960 population for the geographic area (typically a city or county unit) in which the building is located. The data bank from previous studies<sup>2,3</sup> was used to determine:

1. The number of people living within a 15- and 30-min walk\* of the building based on (1) 1960 census data and on (2) 1975 projected population (OCD),
2. the number of PV 71 and 81 shelters located within the same distances of the building,
3. the number of potential shelters from new transportation structures within the same distances,
4. the area code\* of the grid square in which the building is located.

The 1970/1960 population ratio was used to calculate, from the 1960 census data, the number of people living within a 15- and a 30-min walk of the building.

All the data obtained were put on IBM cards for input to the computer. A computer program (FORTRAN IV) was written to read and compile the data, to make certain calculations, and to display the data in tabular form convenient for analysis. The tabular displays are included in the appendices of the final report.<sup>1</sup>

#### 15.4 CONCLUSION

The potential for improving the quality of civil defense shelters by blast slanting the underground spaces in new government buildings is not great. A long-range program which would require all basement spaces in new federal government buildings to be blast slanted would provide no more than 750,000 spaces

over a ten-year period. If these could be blast slanted for \$60 per space, the increase in the construction budget would be only \$4.5 million per year, less than one-tenth of one percent of the annual federal government construction budget and only one-half of one percent of the budget of the federal agencies which normally build new buildings. It should be noted that this estimate of potential space is based on a compilation which includes considerable post office space, but the change in the method of operation of the post office has already made drastic reductions in the projected floor space to be built in the future for the Postal Service.

One factor which is difficult to evaluate from these data is the reduction in federal construction during the last two years in order to fight inflation. These data include a number of buildings which have been or are being designed but for which the construction money has not been made available. A long delay in approving such construction could generate a great demand for more federal office building space. Then, assuming an expanding economy during the next few years, a much larger number of shelter spaces than predicted here might become feasible. However, even a factor of 5 increase would not change the basic conclusion.

Another factor that has been omitted in this study is the potential shelter spaces in National Guard armories and Reserve Unit training facilities being built with Defense Department funds. Such spaces could possibly be made available for reservists and their families. However, the total reserve components construction budgets have been averaging about \$20 million per year. Assuming 2% of the budget (a value slightly higher than the average for the 78 buildings reported) for blast slanting at \$60 per shelter space, a ten-year program would produce less than 70,000 additional shelter spaces.

It is possible that the buildings being constructed for or by non-federal governmental agencies (i.e., state and local) could add to the total potential space. According to Department of Labor projections,<sup>13</sup> construction by state and local governments is about five times as much as the construction financed by the federal government. Assuming the same proportion of slantable space, this could provide 4.75 million spaces during the decade and perhaps more than 10 million if the inflation issue were involved here also.

The small amount of blast shelter space which can be made available by all three programs suggested in the introduction (i.e., upgrading PV 71 and 81 shelters, blast slanting spaces in transportation structures, and blast slanting basement spaces in new government

\*The method of obtaining the 15- and 30-min walk data and the area code designation are explained in detail in ref. 3.

Table 15.1. Summary of blast shelter spaces by dual-purpose options

Spaces in millions					
	Existing	Added by ventilation	Added by slanting	Total spaces	Total with crowding option
PV 71 and 81	13	7		20	50
Transportation systems			10	10	25
Federal, state, and local government buildings			5.5	5.5	16.5
Required by private sector				144.5	88.5
Total	13	7	15.5	180	180

buildings) indicates that the dual-purpose shelter approach to blast shelters will not be adequate unless the private sector can be brought into such a program. The total potential in all government options even including the "crowding" option would not provide more than 91.5 million blast-resistant spaces.

Assuming that the Civil Defense shelter policy requires 180 million blast shelter spaces by 1980, the deficit remaining after incorporation of all options thus far suggested is shown in Table 15.1. Involving the private sector in a dual-purpose shelter program would require an incentive program, or subsidy, of some sort. Assuming that the private buildings to be built in the next ten years can provide the necessary blast slanted spaces (at \$60 per space), the subsidy program would cost close to \$1 billion per year to provide the total required of nearly 150 million spaces. However, the cost of a program to construct a system of single-purpose 15-psi blast shelters is higher, by a factor of 2.25 to 4.5 (see Table 15.2).

#### REFERENCES

1. G. A. Cristy, "Blast Shelter Potential in New Government Buildings," ORNL-TM-3664 (March 14, 1972).
2. *Annual Progress Report, Civil Defense Research Project, March 1969-March 1970*, ORNL-4566, p. 58.
3. G. A. Cristy, *Transportation Systems and Dual Purpose Blast Shelters - Final Report*, ORNL-4675 (October 1971).
4. C. H. Kearny, *Manual Shelter Ventilating Devices for Crowded Shelters Cooled by Outside Air*, ORNL-TM-1154 (June 8, 1965).
5. A. L. Kapil and C. E. Rathmann, *Shelter Ventilator Studies*, General American Research Division Final Report 1471-1 (January 1971).
6. R. A. Krupka, *Final Report - Overcrowding*

Table 15.2. Cost<sup>a</sup> of single-purpose 15-psi blast shelters

	Austere isolated shelters	Austere interconnected shelters
Cost per space	\$150	\$300
Yearly cost to provide 150 million spaces in 10 years	\$2.25 billion	\$4.5 billion

<sup>a</sup>Cost estimate is based on Haaland's<sup>14</sup> data for Detroit, Michigan.

*Potential*, Hudson Institute Report HI 361-RR/4 (June 11, 1964).

7. E. C. Harvey and J. F. Mahar, *Interim Solutions to Shelter Deficits*, Stanford Research Institute, April 1967.

8. C. H. Kearny, "Hasty Rural Shelters," *Annual Progress Report, Civil Defense Research Project, March 1969-March 1970*, ORNL-4566, p. 67.

9. C. H. Kearny, *Some Aspects of Israeli Civil Defense*, internal memorandum, Civil Defense Project, ORNL, Feb. 16, 1971.

10. H. L. Murphy, *Feasibility Study of Slanting for Combined Nuclear Weapons Effects*, Stanford Research Institute Technical Report, October 1970.

11. *National Locator Code*, prepared by Bureau of the Census for the Office of Civil Defense and the Office of Emergency Planning, 1962 (8 volumes).

12. *U.S. 1970 Census of Population Final Population Counts*, Series PC (VL), December 1970.

13. *Projections 1970*, U.S. Department of Labor Bulletin 1536.

14. C. M. Haaland, *System Analysis of U.S. Civil Defense via National Blast Shelter Systems*, ORNL-TM-2457, p. 123 (March 1970).

## 16. Active-Passive Defense in Detroit

C. M. Haaland

### 16.1 INTRODUCTION

In the last annual report,<sup>1</sup> a methodology was described and applied to Washington, D.C. and Minneapolis-St. Paul to investigate the effect of various tradeoffs between active and passive defense. In this report, the same methodology is applied to Detroit with two additional inputs: (1) locations for potential shelter sites for the inner city of Detroit are taken from an on-site evaluation by Bechtel Corporation<sup>2</sup> and (2) resident population on a block-by-block basis from the 1970 census is used to estimate the time required to reach shelters.

### 16.2 THE BECHTEL SHELTER SITES

Figure 16.1 shows the Bechtel shelter locations and zone boundaries in the inner city of Detroit. Sites were selected on public property such as school yards and parks. Locations were chosen so that hardly anyone would have more than about a quarter-mile walk to shelter. Capacities of shelters were chosen to hold the peak daytime population as projected by Bechtel to 1970 and 1975 from the 1964-1965 data provided by various sources in the city.

The shelter capacities determined by Bechtel were not used for our study for two reasons: (1) The Bechtel study assumed people could not cross a zone boundary to a shelter in another zone even if that shelter were across the street, an impractical and unworkable plan in our opinion; (2) the Bechtel population projection predicted a net decrease in resident population of 9% for the area from 1960 to 1970 (20% decrease 1960 to 1965, from 264,468 to 210,000, and, incorrectly, a 14% increase 1965 to 1970), whereas the actual resident population decreased from 264,468 in the 1960 census to 173,900 in the 1970 census, a decrease of 34%. However, the capacities of the Bechtel shelters were determined primarily on the basis of a 1965 estimate of the downtown daytime peak population, which was about 480,000 people, about 2.3 times the estimated resident population at that time of 210,000 people. No attempt has been made to estimate the

current peak downtown population, although there is a consensus among people contacted in Detroit (Corps of Engineers, Mayor's Office, Southeast Michigan Council) that there have been drastic changes made in downtown Detroit since 1965, including 22 new buildings costing \$187 million which have been completed in the last five years.

The locations of the Bechtel shelter sites were digitized in the same manner as the block centroids. The population of each block, as determined from the 1970 census, was entered on cards, along with coordinates and block numbers. A dot map representing the block centroids (dots) and shelter locations (asterisks) is shown in Fig. 16.2.

### 16.3 MOVEMENT TO SHELTER

Two models were used to simulate movement of people to shelter. In the simple model, all the people were assumed to start walking simultaneously at a time 2 min after warning, they started from a point at the centroid of their block, they all walked at the same speed, they walked to the nearest shelter along rectangular paths, and there was no queuing at the shelter to get in.

In a more complicated model, some people were assumed to start moving immediately from the point at the centroid of their block, others started moving at later times. The curve representing their distributed departures was assumed to follow a gamma density function, shown by curve A in Fig. 16.3. The parameters of this curve are chosen such that 50% of the people have left at 2 min after warning. Furthermore, some people are assumed to walk faster than others, and the distribution of velocities is assumed to be represented by a parabolic function. The arrival times, *without* a distributed departure, are shown by curve B, corresponding to minimum and maximum walking speeds of 3 and 4 mph. Curve C represents a convolution of curves A and B to show the fraction of the population arriving at shelter at a specific time, and curve D shows the cumulative fraction of the population which has arrived at shelter at a given time.

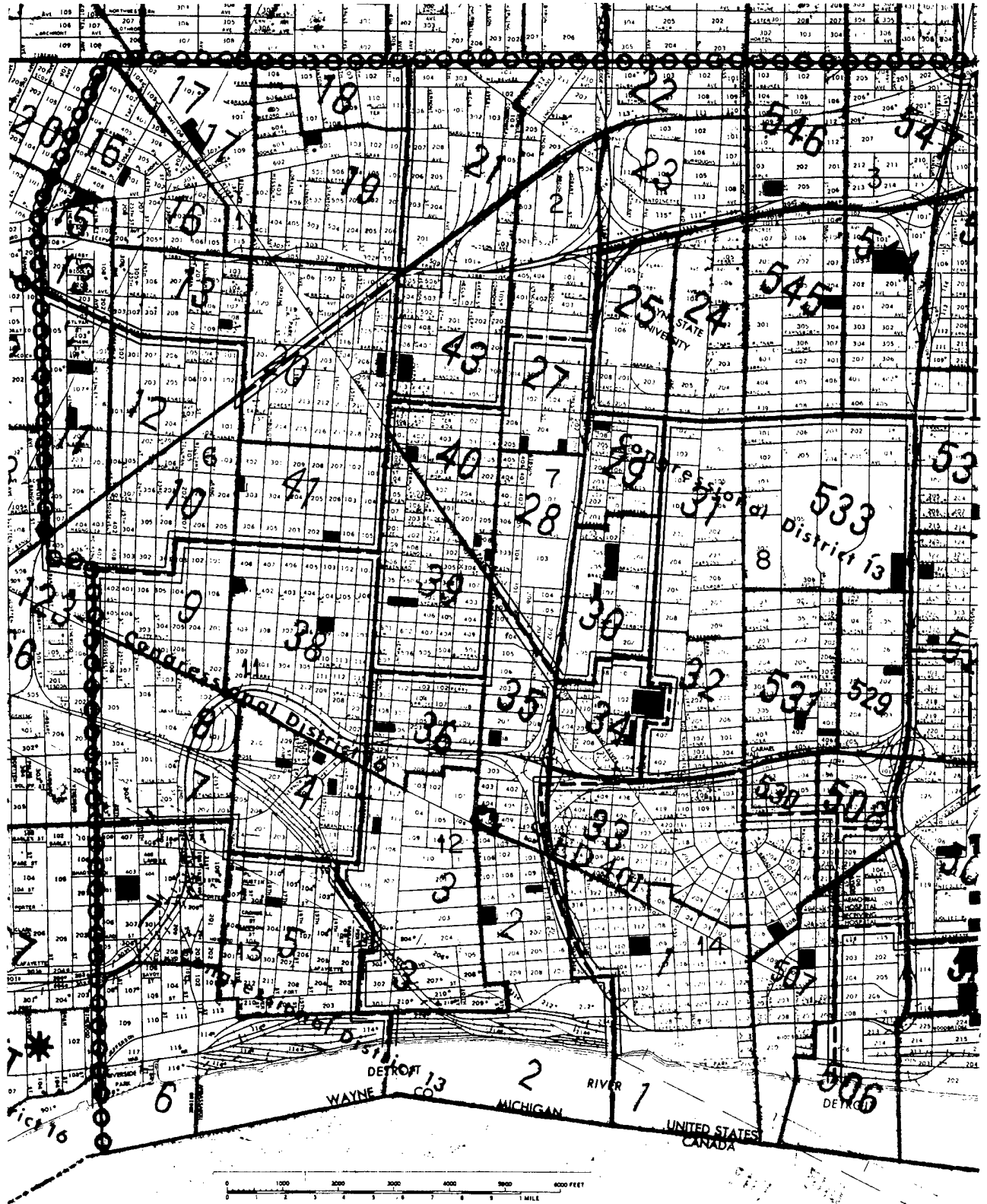

The inner city of Detroit, with 1970 Census tract numbers in the small red numerals. Heavy red lines show Census tract boundaries, small red shelter zone numbers and potential shelter sites, as determined by Bechtel C

(1)

Fig. 16.1

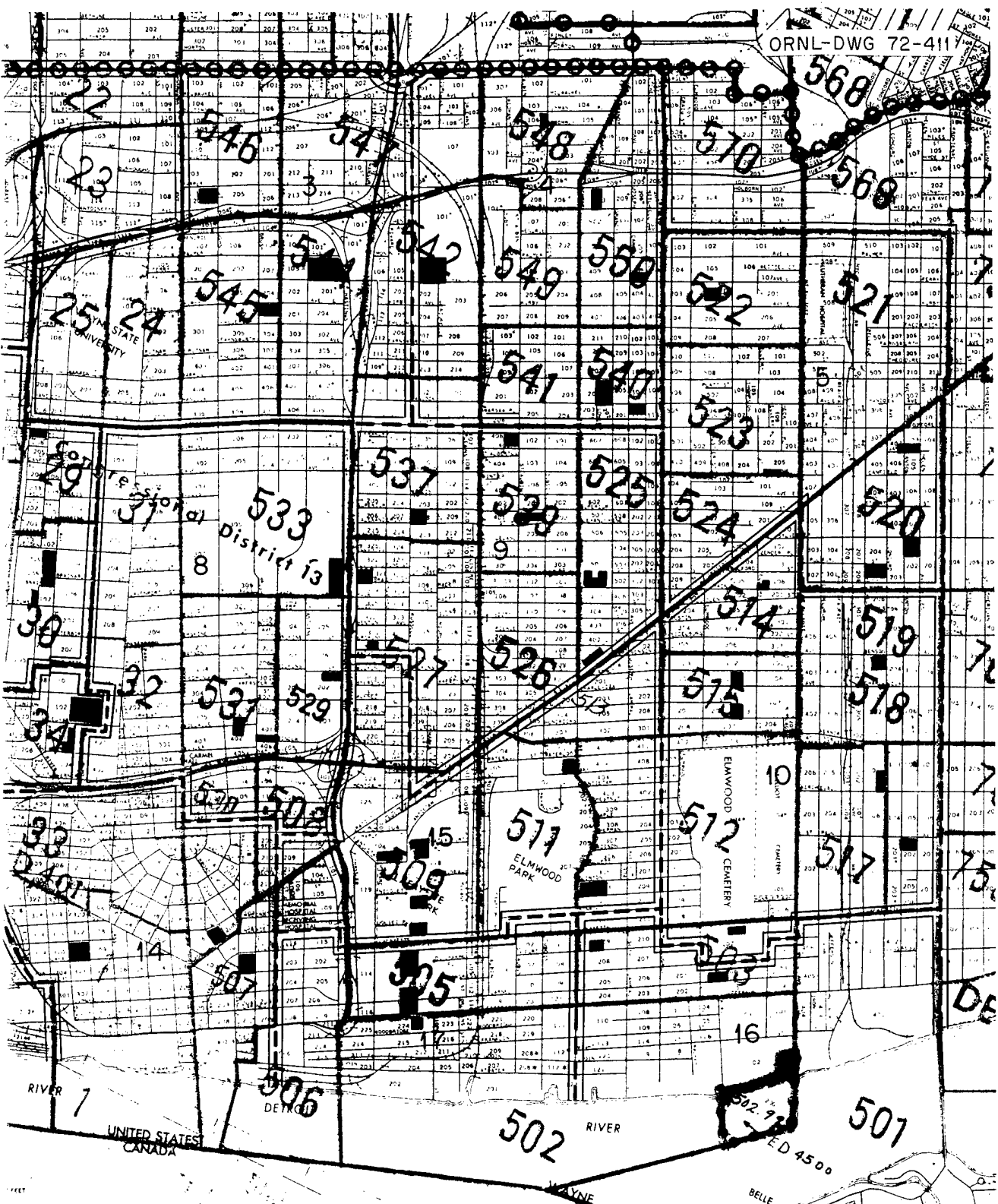

troit, with 1970 Census tract numbers in large red numerals, and block numbers in black. The map shows Census tract boundaries, small red lines show streets. The shelter zones, and shelter sites, as determined by Bechtel Corporation, are shown in black.

Fig. 16.1

(2)

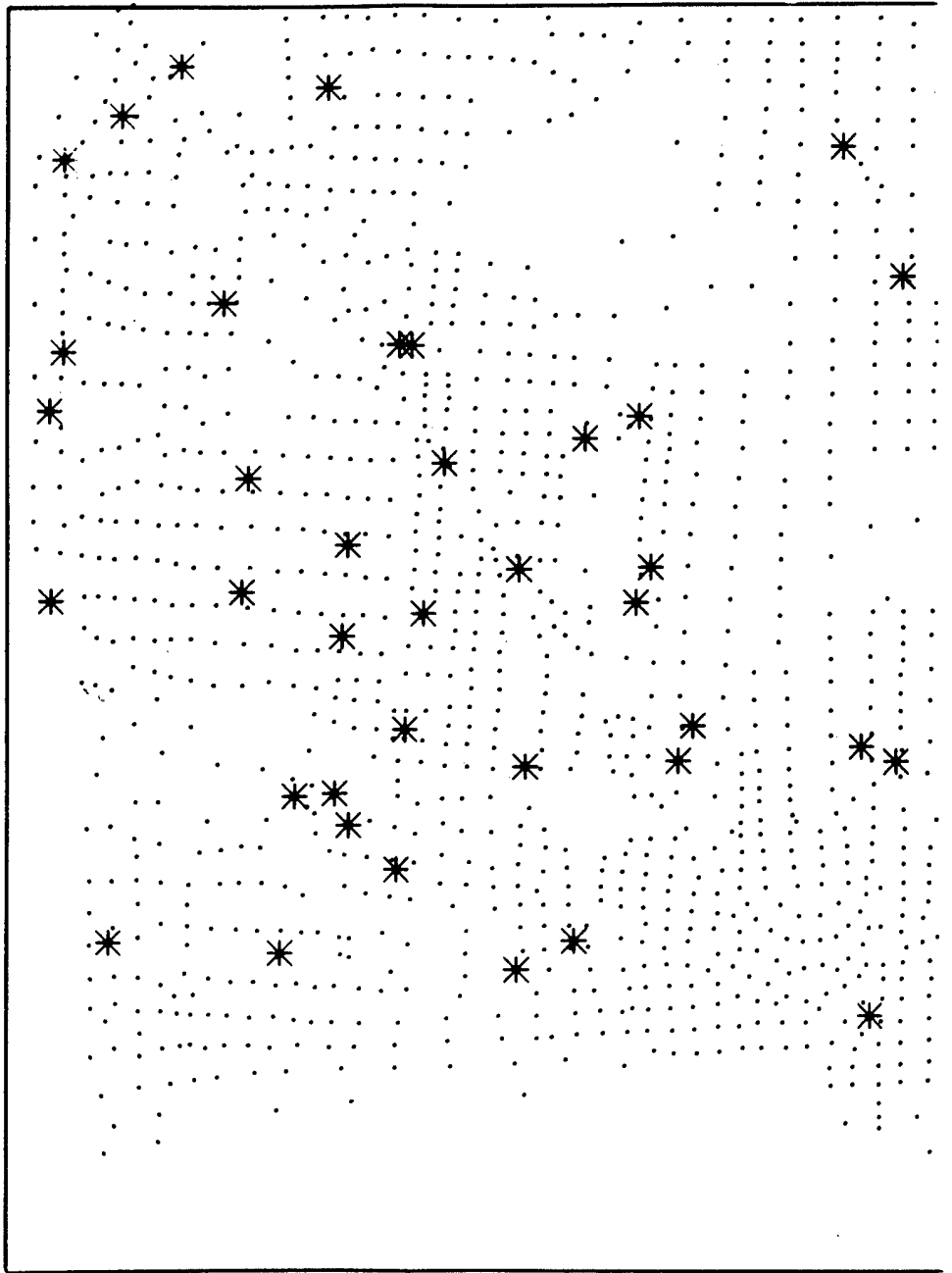
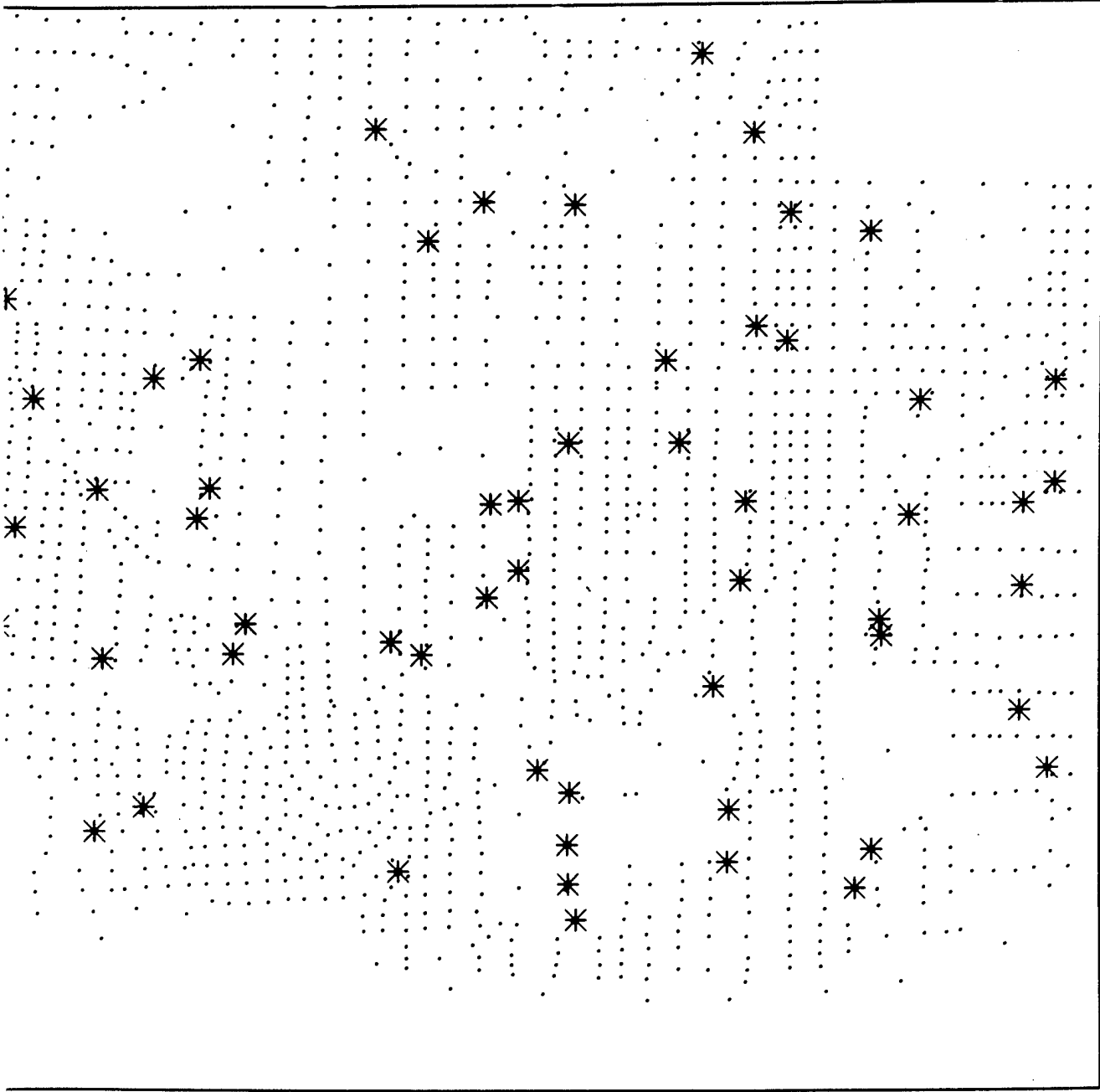

Fig. 16.2. Map of block centroids (dots) for the inner city of Det (asterisks) superimposed.

(1)



Map of block centroids (dots) for the inner city of Detroit, 1970 census, with Bechtel shelter locations superimposed.

(2)

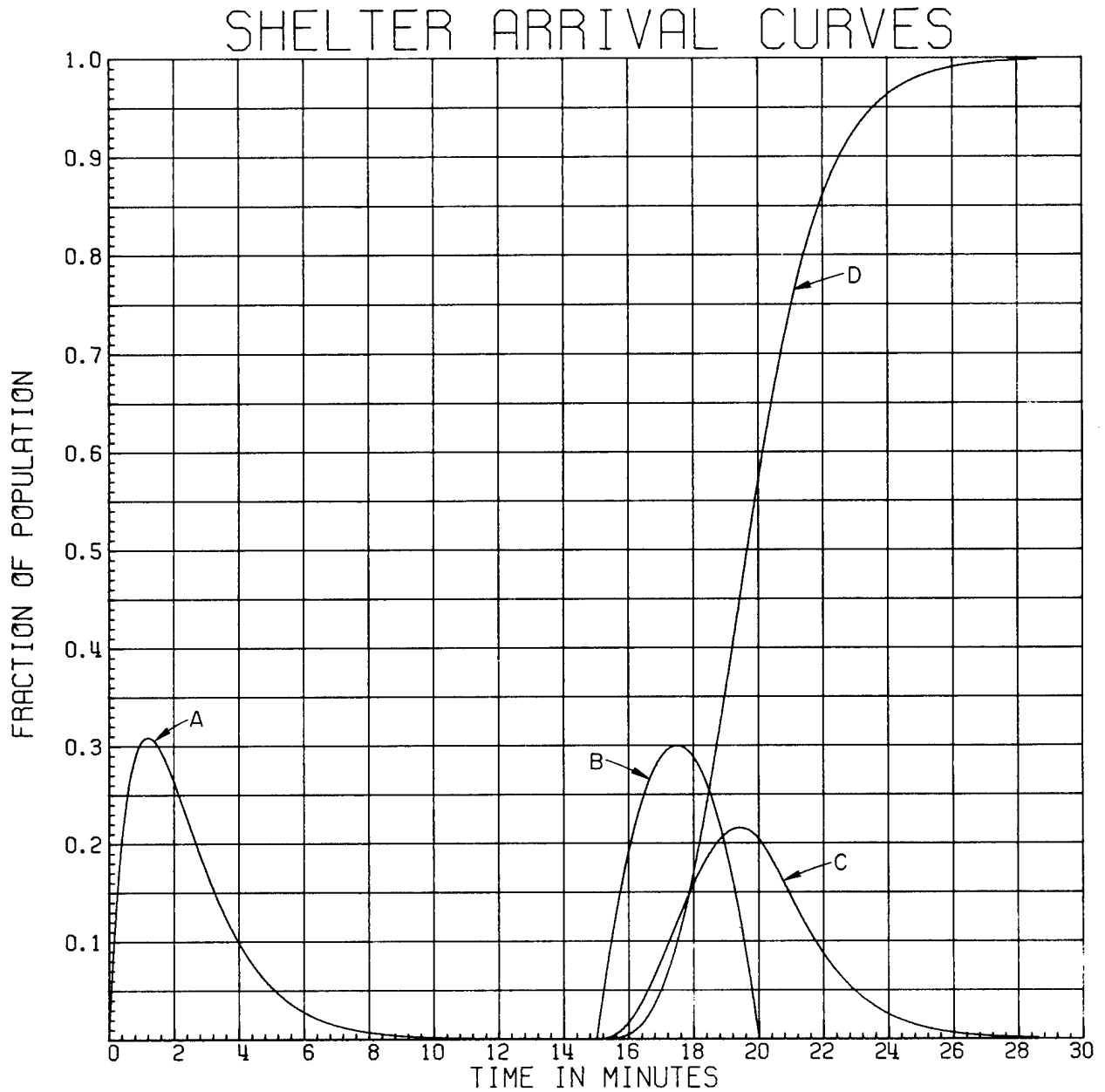

Fig. 16.3. Sample of functions representing shelter arrival analysis. Curve A represents the distribution in time of people starting to move to shelter, with 50% leaving at 2 min after warning. Curve B represents the distribution in time of arrival at shelter one mile from the starting point, if all people started simultaneously. Curve C represents the arrival at shelter from a convolution of curves A and B. Curve D represents the cumulative arrival from curve C.

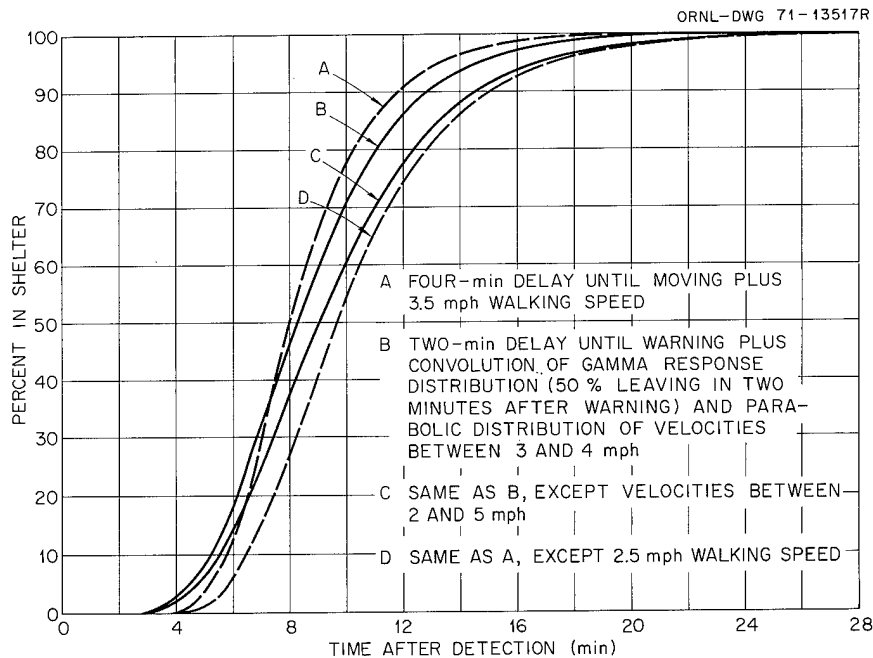

Fig. 16.4. Estimated percent of resident population of inner city of Detroit reaching Bechtel shelters as a function of time after detection of an attacking missile force.

The two models just described were applied to each of the 1957 city blocks in the inner city of Detroit for movement to the Bechtel shelters, and the results were totaled to find the cumulative fraction in shelter at a given time for the entire area. The results for four cases are shown in Fig. 16.4. Curves A and D represent the simple model with walking speeds of 3.5 and 2.5 mph, respectively. These curves bracket (in the region above 40% in shelter) the two curves B and C which result from the more complicated model. It is evident from these curves that the simple model is quite adequate to represent the movement of people to shelter.

The average distance per person to the Bechtel shelters was 1387 ft, slightly over a quarter-mile, and the average distance per block was 1483 ft.

#### 16.4 ACTIVE-PASSIVE DEFENSE INTERACTION

In order to use the methodology previously developed<sup>1</sup> for investigating active-passive tradeoffs with a shelter spacing equivalent to that of the Bechtel study, it was necessary to relate the Bechtel spacing to that of the model in which hypothetical shelters are located at the centers of squares which fit into 5-km quadrangles. The mean distance per person to shelter at the center of

a square of side  $D$ , along rectangular paths, is  $D/2$ ; hence, the Bechtel shelter spacing would correspond in the model to shelters located in squares with a side length of 2774 ft, and six of these (slightly smaller) would fit along the edge of a 5-km quadrangle, totaling 36 shelters inside a 5-km quadrangle. The 1970 population of the inner city was 173,900 over an area of 41.5 km<sup>2</sup>, which becomes 104,700 people over a 25-km<sup>2</sup> quadrangle, assuming uniform density. The Bechtel shelter locations would therefore correspond to a maximum capacity of 2910 (plus 30% for transients) spaces in the hypothetical shelters located in the centers of squares.

Before the 1970 census data became available to us, the active-passive model was used for Detroit to calculate tradeoffs for "slanted" shelters averaging a maximum of 200 and 1000 spaces per shelter, and also for family shelters using the SRI population projection to 1975 for Detroit. The costs for shelters and for Safeguard components are described in ORNL-TM-3485, Vol. I.<sup>3</sup>

Two examples of the results are shown in Figs. 16.5 and 16.6, corresponding to city defense budgets of 1 and 1.5 billion dollars, respectively. In both cases, it is

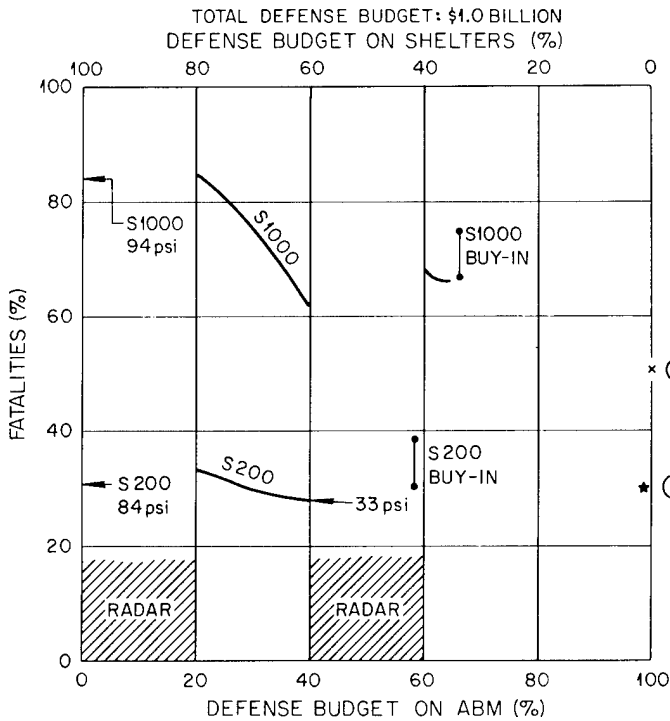

CITY: DETROIT  
 POPULATION: 4.486 million  
 NUMBER OF ATTACKING WEAPONS  
 IN 16 SALVOS: 230 (N)  
 YIELD: 0.1 MT, SURFACE BURSTS  
 TIME BETWEEN SALVOS: 5 sec ( $t_p$ )  
 SLBM FLIGHT TIME: 6.4 min ( $t_f$ )  
 POPULATION RESPONSE TIME: 4 min  
 AVERAGE WALKING SPEED TO SHELTER: 3.5 mph

- ① ALL ABM, 200 INTERCEPTORS, 30 WEAPONS DELIVERED, POPULATION UNWARNED, UNSHELTERED
- ② ALL ABM, 200 INTERCEPTORS, 30 WEAPONS DELIVERED, NO SHELTERS, POPULATION WARNED AND TRAINED

SHELTER COST SCHEDULE NO. 2

Fig. 16.5. Passive-active tradeoffs for the Detroit SMSA showing expected fatalities as a function of various apportionments of the \$1 billion defense budget between passive and active defense.

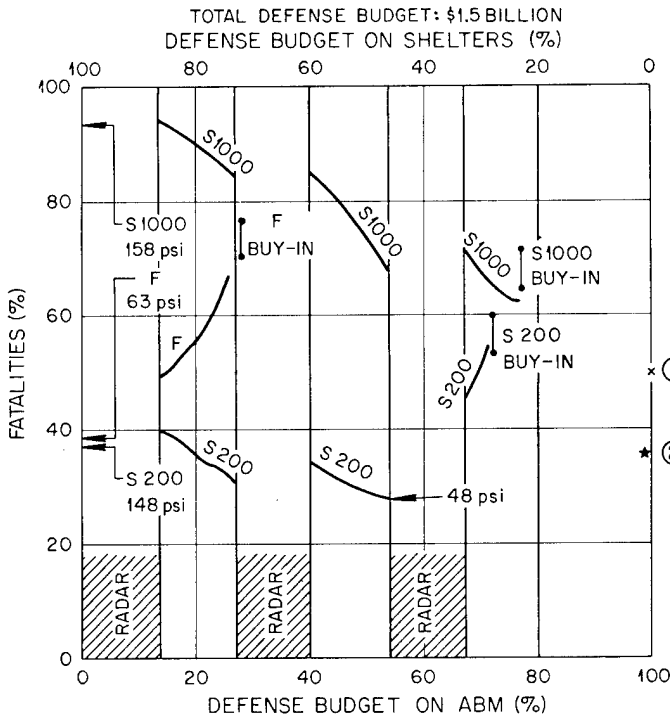

CITY: DETROIT  
 POPULATION: 4.486 million  
 NUMBER OF ATTACKING WEAPONS  
 IN 16 SALVOS: 380 (N)  
 YIELD: 0.1 MT, SURFACE BURSTS  
 TIME BETWEEN SALVOS: 5 sec ( $t_p$ )  
 SLBM FLIGHT TIME: 6.4 min ( $t_f$ )  
 POPULATION RESPONSE TIME: 4 min  
 AVERAGE WALKING SPEED TO SHELTER: 3.5 mph

- ① ALL ABM, 350 INTERCEPTORS, 30 WEAPONS DELIVERED, POPULATION UNWARNED, UNSHELTERED
- ② ALL ABM, 341 INTERCEPTORS, 39 WEAPONS DELIVERED, NO SHELTERS, POPULATION WARNED AND TRAINED

SHELTER COST SCHEDULE NO. 2

Fig. 16.6. Passive-active tradeoffs for the Detroit SMSA showing expected fatalities as a function of various apportionments of the \$1.5 billion defense budget between passive and active defense.

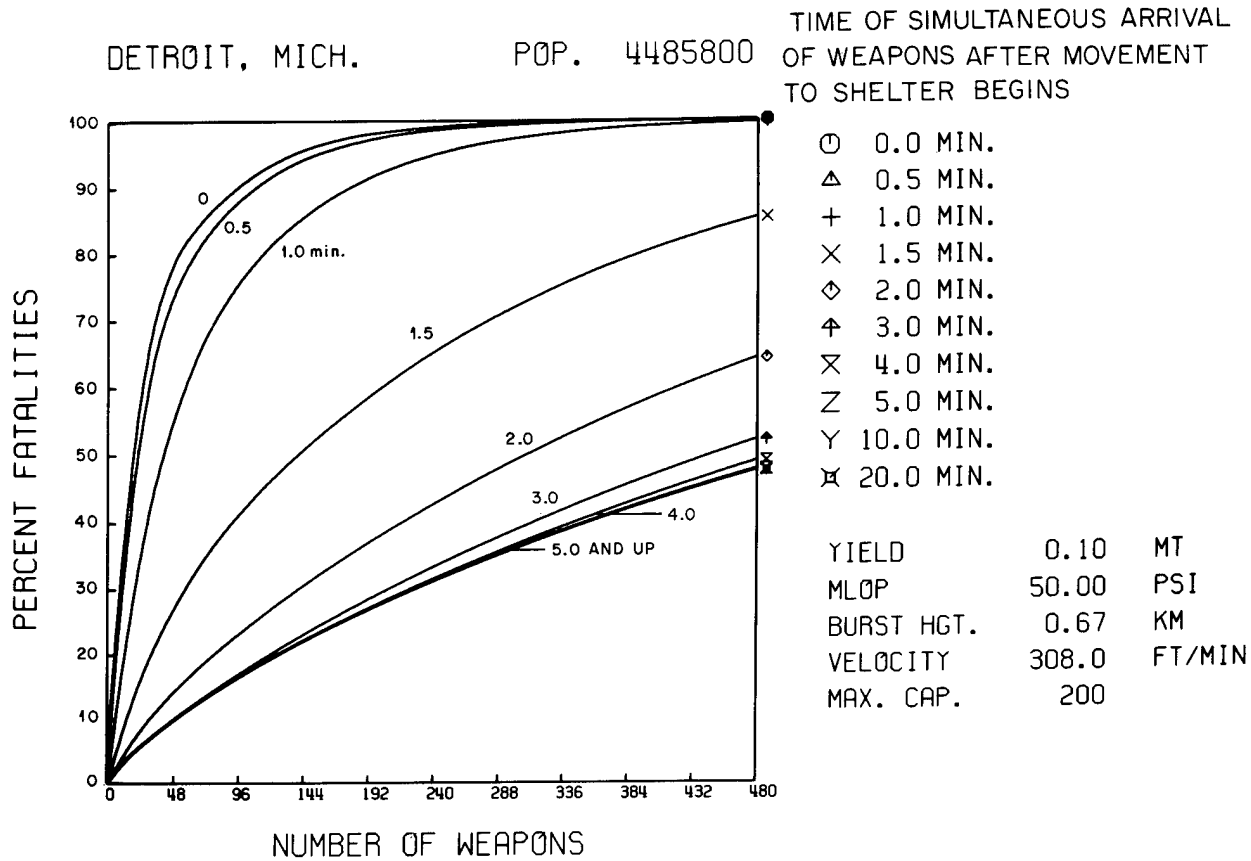

Fig. 16.7. Percent fatalities vs number of weapons for various times of arrival of weapons after movement has begun to shelters which have maximum capacities of 200 persons.

assumed that the attack size is determined by the number of interceptors purchased for defense when the entire defense budget of the city is spent on ABM, and, in this case, the attacker attempts to kill 50% of the population. In both cases, the best combination of active and passive defense consists of 200-person "slanted" shelters combined with ABM, 40% ABM for a \$1 billion budget and 55% ABM for a \$1.5 billion budget.

The 1000-person shelters result in greater fatalities than the 200-person shelters because the SLBM salvos arrive before people can get into shelter. Shelter spacing corresponding to the Bechtel locations (2910-person shelters) would obviously result in even greater fatalities than the 1000-person shelters; hence, no calculations were made for this case.

It is apparent from Fig. 16.4 for Bechtel shelter that less than 25% of the population would be in shelter under the best warning conditions by the time the first salvo of SLBM's arrived.

Figures 16.7 and 16.8 show percent fatalities as a function of number of arriving 0.1-MT weapons, air burst, for various times of arrival of weapons after people start walking to 50-psi MLOP shelters having a maximum capacity of 200 and 1000 persons, respectively. If people start walking at 3.5 min after detection, then, by the time the SLBM weapons arrive about 3 min later, the estimated fatalities from 96 weapons delivered would be about 22% for the 200-person shelters and about 52% for the 1000-person shelters.

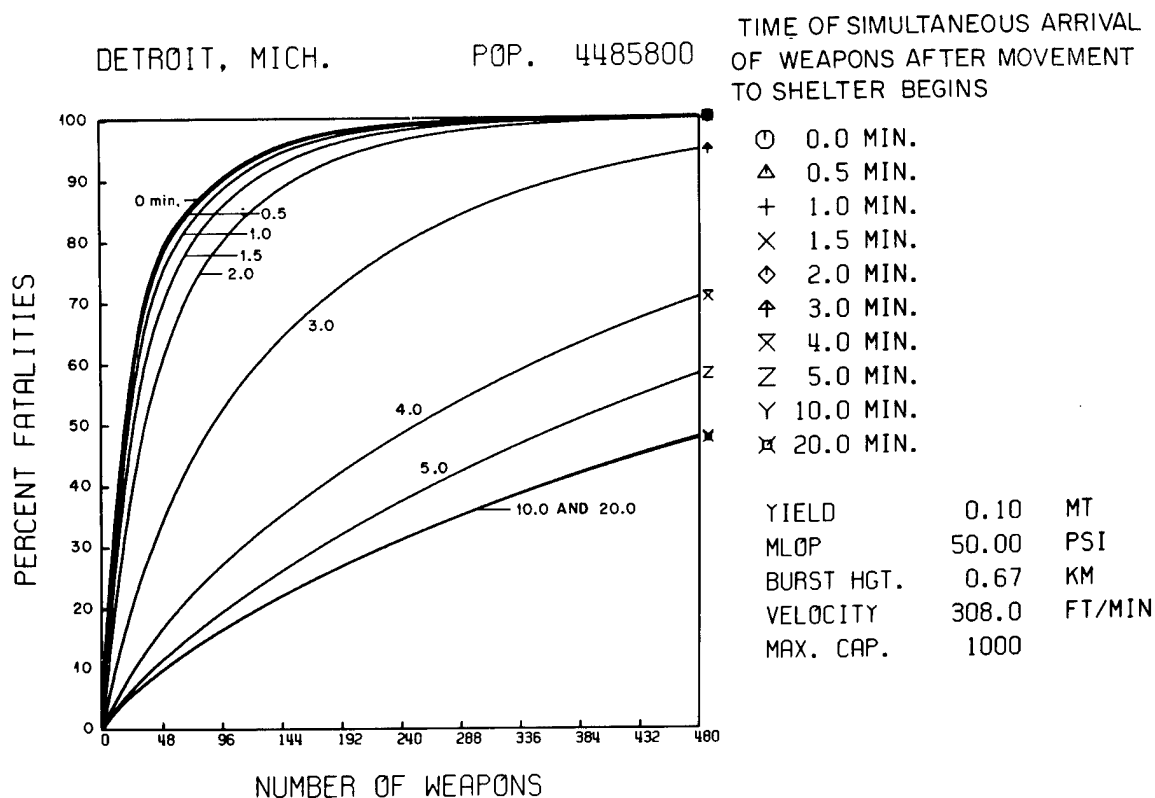

Fig. 16.8. Percent fatalities vs number of weapons for various times of arrival of weapons after movement has begun to shelters which have maximum capacities of 1000 persons.

### 16.5 CONCLUSIONS

(1) The spacing between shelters as determined by the Bechtel study is too great to allow effective occupancy in case of an SLBM threat, and is less cost effective than smaller shelters with closer spacing when combined with ABM to hold off the attack until people get into shelter.

(2) If a shelter program is inaugurated, provisions must be made for continuing development after the initial construction, in order to remain useful to cities which have dynamic changes in growth and patterns such as those in Detroit.

### REFERENCES

1. *Annual Progress Report, Civil Defense Research Project, March 1970-March 1971*, ORNL-4679.
2. *Final Report for Protective Blast Shelter System Analysis, Detroit, Michigan*, Bechtel Corporation, Gaithersburg, Maryland, June 1968.
3. C. M. Haaland, E. P. Wigner, and J. V. Wilson, *Active and Passive Defense Interaction Studies*, ORNL-TM-3485, Vol. I, December 1971 (Unclassified).

# III. Weapons Effects

## 17. Studies of Nuclear Electromagnetic Pulse (EMP) Effects on Power Systems

J. K. Baird   J. H. Marable   D. B. Nelson

### 17.1 THE COUPLING OF EMP INTO ELECTRIC POWER SYSTEMS

#### 17.1.1 Introduction

The principal purpose of these EMP coupling studies is to calculate voltages and currents induced by EMP pulses in overhead lines of various lengths and orientations. This computational ability is basic to all our investigations.

The coupling problem can be broken down into a number of parts. The first part is that of describing the original incoming electromagnetic pulse. The second part involves the reflection of the pulse from the ground. Next, the electrical properties of the lines and the associated interconnecting apparatus, such as transformers, must be described mathematically. Then the currents and voltages at various points in the network are calculated as a function of frequency. Finally, the currents and voltages are transformed from the frequency domain into functions of time.

#### 17.1.2 Transforming from Frequency to Time

In the past this latter transformation from frequency to time, sometimes referred to as the inverse transform, was done by deforming paths of integration in the complex plane. The particulars were different for different problems. Often one ended up with a definite integral or several integrals which had to be integrated numerically.

Such a procedure is not adequate for general survey-type calculations over a wide range of physical setups, such as are found in electrical power systems. A more general procedure is the so-called Fast Fourier transform algorithm.<sup>1</sup> This algorithm

requires equal mesh spacing in time as well as in frequency.

A very efficient system for calculating the inverse transform and which we have applied to EMP coupling problems for the first time is the Gaussian integration method.<sup>2,3</sup> In contrast to the usual method of calculating the currents and voltages at arbitrarily selected and usually equally spaced frequencies, the Gaussian technique prescribes the frequency values at which the current and voltages are to be calculated. It does this in such a manner so as to minimize the error in calculating the inverse transform of certain polynomials.

The Gaussian technique is very efficient. For double precision numbers on the IBM 360, a 24-point routine is quite adequate. Furthermore, for real functions of time, which is always the case for the voltages and currents of interest, there is a certain mirror symmetry in the complex frequency plane which effectively reduces the number of points by a factor of 2. This means that the functions must be calculated at only 12 points in the complex frequency domain in order to get the value of a function at a single time.

The form of the Gaussian integration used for the inverse transform is<sup>2</sup>

$$g(t) = \frac{1}{2\pi i} \int_{c-i\infty}^{c+i\infty} e^{st} G(s) ds \cong \sum_{i=1}^{12} \left\{ A_i \left[ \frac{p_i}{t} G\left(\frac{p_i}{t}\right) \right] + A_i^* \left[ \frac{p_i^*}{t} G\left(\frac{p_i^*}{t}\right) \right] \right\}, \quad (1)$$

where  $A_i$  and  $p_i$  are tabulated constants and  $A_i^*$  and  $p_i^*$  are the complex conjugates.

Of course, a certain numerical complication arises because, in the frequency domain, one must calculate values of complex functions of complex variables. This is not too severe, however, since all the elementary functions and arithmetic operations are available in complex form on the computers, and the availability of complex functions, in general, is increasing.

In fact, it is largely because the functions are calculated in the complex frequency domain that the use of the Gaussian technique is attractive. This helps to assure that the functions to be transformed have a certain analytic property. The lack of this analytic property may cause difficulties in which the transform may not exist for all values of the parameters of interest, or in which small changes in the parameters may cause large changes in the transform.

In order to make use of this Gaussian integration technique, all quantities which are to be transformed into functions of time must be written as functions of  $s$  analytic in the right half plane. This will be apparent in the following.

### 17.1.3 Description of the Incident Pulse

The characteristics of the incident electromagnetic pulse have been described in previous reports.<sup>4,5</sup> A brief description is repeated here in order to give the assumptions under which our study has been made and in order to show the generality in our ability to calculate various geometries.

The concern here is with EMP from a high-altitude burst in which the incident pulse is assumed to be an electromagnetic plane wave directed from the burst point toward the observer. The electric field has a direction at right angles to this.

This latter direction of the electric field is known as the direction of polarization. It is of interest for two reasons: (1) The reflection of the pulse from the earth depends on the polarization and (2) the coupling of the pulse to transmission lines depends on the polarization. A rule of thumb says that the direction of polarization is at right angles to the earth's magnetic field as well as to the direction of propagation. Thus, for a geomagnetic dip angle of  $67^\circ$ , which is an average for the state of Tennessee and a reasonable average for the United States, one can easily see that the direction of polarization should lie off the horizontal by some angle like  $23^\circ$  or less depending upon the direction of propagation.

The wave shape and magnitude of the EMP as a function of time are variable depending on a number

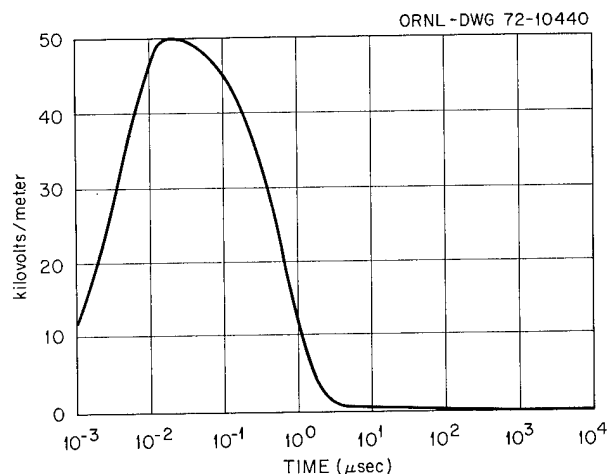

Fig. 17.1. The electric field of the representative pulse calculated by Gaussian integration of the inverse Laplace transform of Eq. (4).

of parameters. In order to simplify the approach, a representative pulse is chosen which lies between an "average" pulse and a reasonable "worst-case" pulse.

The electric field of this representative pulse is shown in Fig. 17.1 and is given mathematically<sup>5</sup> by

$$E(t) = E_0(e^{-\alpha t} - e^{-\beta t}) \quad t > 0, \quad (2)$$

where

$$\begin{aligned} E_0 &= 5.0 \times 10^4 / 0.9646 \text{ V/m}, \\ \alpha &= 1.5 \times 10^6 \text{ sec}^{-1}, \\ \beta &= 2.6 \times 10^8 \text{ sec}^{-1}. \end{aligned} \quad (3)$$

In the frequency domain the pulse is given by

$$E = \frac{E_0(\beta - \alpha)}{(s + \alpha)(s + \beta)}, \quad (4)$$

where  $s$  is related to the frequency  $\omega$  by

$$s = i\omega.$$

The curve in Fig. 17.1 was calculated not from Eq. (2) but by the Gaussian integration of its transform in Eq. (4).

### 17.1.4 Reflection from the Ground

The contribution to the electric field due to the reflection of the EMP from the ground has been calculated in the past for horizontal polarization of

the incident field and constant ground properties.<sup>6</sup> In particular, a constant conductivity and a constant dielectric constant were assumed.

Experimental studies<sup>7</sup> indicate that the properties of the ground are not constant but are functions of the frequency. This frequency dependence in the range of interest is apparently due to the inhomogeneous structure of the ground.

In order to use the results of the experimental studies in the calculation of the reflection of EMP off the ground, the complex dielectric constant was fitted by a sum of terms of the classical Debye type, that is,

$$\kappa(s) = \kappa_{\infty} + \sum_{i=1}^4 \frac{A_i}{1 + sT_i} + \frac{\sigma_0}{s\epsilon_0}. \quad (5)$$

Here,  $\epsilon_0$  is the permittivity of free space,  $\kappa(s)$  is the complex dielectric constant, the imaginary part of which represents the conductivity,  $\kappa_{\infty}$  is the high-frequency dielectric constant, the coefficients  $A_i$  are real positive constants chosen to fit the experimental data, and the periods  $T_i$  were chosen so as to span the frequency range represented by the experimental data. The values of  $T_i$  chosen are given by  $T_i = 2/\pi 10^{-(i+3)}$ . The  $\sigma_0$  appearing in Eq. (5) is the low-frequency conductivity. It is primarily a function of the water content of the ground. This parameter  $\sigma_0$  was used to characterize the soil in the experimental studies; it is accordingly a parameter determining the values of the coefficients  $A_i$  and  $\kappa_{\infty}$ , and hence determining the frequency dependence of the conductivity as well as of the dielectric constant.

The incident EMP may be decomposed into two polarization components, one horizontal and perpendicular to the plane of incidence and the other lying in the plane of incidence. Reflection coefficients for each of these two polarization components have been calculated in terms of simple analytic functions of  $\kappa(s)$  and  $s$  according to Fresnel's standard formulas.<sup>8</sup>

An example of the combination of incident field plus the reflected field is given in Fig. 17.2. Note the more rapid drop of the field as compared with the incident field alone in Fig. 17.1, indicating the importance of ground reflection.

### 17.1.5 Electrical Characteristics of Transmission Lines

The EMP-induced current in an infinitely long perfectly conducting wire was given in last year's annual

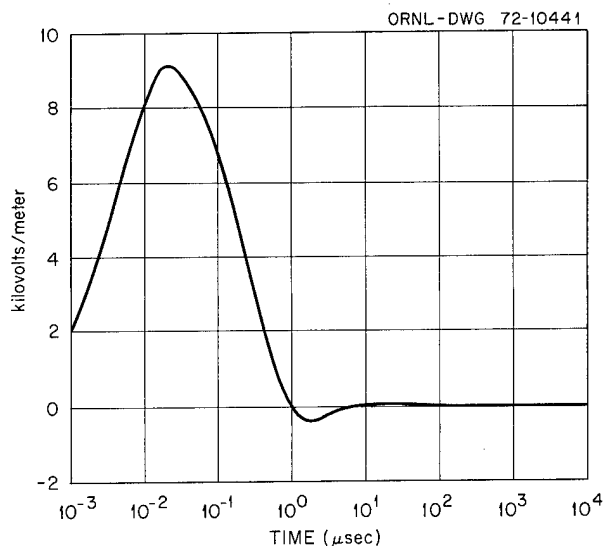

Fig. 17.2. The horizontal component of electric field of the combined incident and ground-reflected fields at a height of 10 m. The ground is characterized by a low-frequency conductivity of 2 millimhos/m. The wave is incident at an angle of 80° with the vertical, and the polarization is in the vertical plane of incidence.

report<sup>9</sup> on the basis of both scattering theory and transmission line theory.

The scattering theory result has been extended to include the effect of finite conductivity in the wire. The resulting effective impedance of the wire per unit length is

$$Z = \left( \frac{\mu_0}{2\pi} \right) s \sin \theta K_0 \left( \frac{sa \sin \theta}{c} \right) + \frac{\lambda s}{2\pi c(\sigma + \epsilon s)} \frac{I_0(\lambda a)}{I_1(\lambda a)} K_1 \left( \frac{sa \sin \theta}{c} \right), \quad (6)$$

where  $\lambda$  is a function of  $s$  defined by

$$\lambda = \sqrt{\mu_0 s} \sqrt{1 + \left( \epsilon - \frac{\cos^2 \theta}{c^2 \mu} \right) \frac{s}{\sigma}},$$

where  $a$  is the wire radius,  $\epsilon$ ,  $\mu$ , and  $\sigma$  are the permittivity, permeability, and conductivity of the wire,  $\mu_0$  and  $c$  are the permeability and velocity of light in vacua, and  $\theta$  is the angle between the EMP propagation vector and the wire axis.

The first term in the above expression for  $Z$  is independent of the conductivity. It is the impedance per unit length presented by a perfectly conducting wire. The second term in the expression is the additional ac resistance and the internal reactance of the

wire and is very similar to the well-known classical expression for these two quantities. This second term depresses the current at late times ( $t \lesssim 1 \mu\text{sec}$ ). For the times of importance to EMP, the effects of the resistance in a good conductor are small. The paradox found last year<sup>9</sup> (whereby the current varied as  $1/\sin \theta$ , giving an infinite current as  $\sin \theta$  went to zero) disappears when the wire has finite conductivity. The  $1/\sin \theta$  dependence is then only approximately valid, and as the  $\sin \theta$  gets very close to zero the current in a wire of finite conductivity also goes to zero.

In addition to extending the results of scattering theory, transmission line theory has been developed. The method of Sunde,<sup>10</sup> which includes the effects of a ground with finite conductivity, has been applied to transmission lines of finite length  $l$ .

With a distributed source, the voltage  $V(l)$  and current  $I(l)$  at one end of the line is related to the voltage  $V(0)$  and current  $I(0)$  at the other end through the relation

$$\begin{bmatrix} V(l) - V_\infty(l) \\ I(l) - I_\infty(l) \end{bmatrix} = \begin{bmatrix} \cosh(\Gamma l) - Z_0 \sinh(\Gamma l) \\ -\frac{\sinh(\Gamma l)}{Z_0} & \cosh(\Gamma l) \end{bmatrix} \times \begin{bmatrix} V(0) - V_\infty(0) \\ I(0) - I_\infty(0) \end{bmatrix}. \quad (7)$$

Here  $\Gamma$  and  $Z_0$  are the propagation constant (a misnomer) and the characteristic impedance of the line as given by Sunde's theory and  $V_\infty(x)$  and  $I_\infty(x)$  are the voltage and current that would appear in a line of infinite length at the point  $x$ . For these infinite-length voltages and currents, transmission line theory may be used to obtain the simple expressions in  $s$  as reported last year. On the other hand, the scattering theory results for infinite lines may be used; their use, however, requires complex Bessel routines. Such complex Bessel routines are available and are presently being adapted to the ORNL computers.

It may be that the appropriate sources for Eq. (7) are not  $V_\infty$  and  $I_\infty$ , as given by scattering theory, but are some modification of these. This is being investigated. Calculations are being performed presently on the basis of transmission-line theory expressions for the sources  $V_\infty$  and  $I_\infty$ .

### 17.1.6 Transformer Modeling for EMP Surges

The impedance and transfer characteristics of three phase transformers subject to fast surges are very

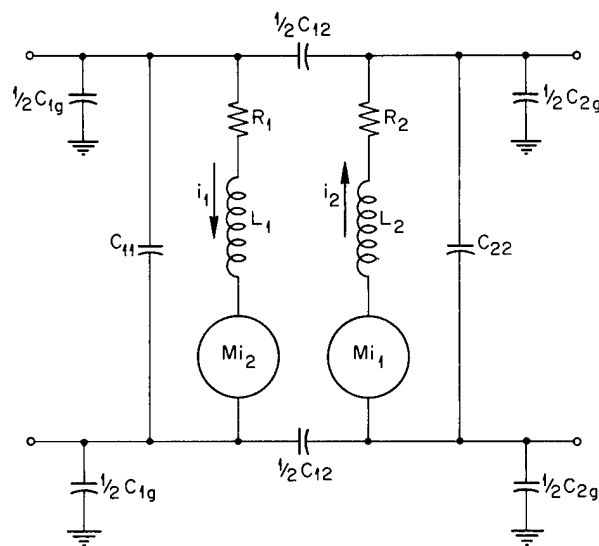

Fig. 17.3. Single-phase transformer model which includes shunt capacitances  $C_{11}$  and  $C_{22}$ , interwinding capacitance  $C_{12}$ , and capacitances to ground  $C_{1g}$  and  $C_{2g}$ , as well as inductive and series-resistive elements.

complicated and involved subjects. As a start, we have represented three-phase transformers by a bank of three similar single-phase transformers. The model of each single-phase transformer in the bank is represented by the schematic diagram shown in Fig. 17.3. This model includes effects of interwinding capacitance, series capacitances, and capacitances to ground.

The parameters are obtained from a variety of sources. Transformer name-plate information provides the kilovolt ratings,  $kV_1$  and  $kV_2$ , of primary and secondary, respectively, as well as the per unit leakage reactance  $X_{pu}$  and the power rating MVA. A leakage inductance

$$L' = \frac{1}{2} \frac{X_{pu}}{2\pi 60} \frac{kV_1 \cdot kV_2}{\text{MVA}}$$

and an effective turns ratio

$$n = kV_1/kV_2$$

are calculated from this information.

A typical transformer iron has a flux penetration characterized by a time constant<sup>11</sup>

$$T_1 = 6.5 \mu\text{sec}.$$

The mutual inductance is then given as a function of frequency by

$$M(s) = M_0 \frac{\tanh \pi \sqrt{sT_1}}{\pi \sqrt{sT_1}},$$

where  $M_0$  is the mutual inductance at low frequencies and is related to the size and shape of the transformer by

$$M_0 = \mu N_1 N_2 A / l,$$

where  $\mu$  is the permeability of the iron,  $A$  is the cross-sectional area of the iron,  $l$  is the length of the flux path in the iron, and  $N_1$  and  $N_2$  are the number of turns of primary and secondary, respectively.

The corresponding self-inductance of the primary is

$$L_1(s) = n[M(s) + L'],$$

and of the secondary,

$$L_2(s) = \frac{1}{n} [M(s) + L'] .$$

The effective resistance of the windings was obtained from engineering tables<sup>12</sup> on the basis of MVA rating and was apportioned to primary and secondary on the basis of equal heat production.

The capacitance values were obtained in part from tabulations<sup>11</sup> and from reasonable guesses based on transformer construction. These capacitance values or, rather, particular ratios of these values are of special importance, since the transformer often looks like a capacitance voltage divider for pulses traveling in the common mode (all three lines have equal currents in phase).

The passage of surges through three-phase transformer banks depends on the type of transformer connection as well as the type of mode of the surge. We have calculated the coupling matrix for common-mode surges passing through delta-delta, delta-grounded Y, delta-ungrounded Y, grounded Y-grounded Y, grounded Y-ungrounded Y, and ungrounded Y-ungrounded Y. Each of these transformer connections looks very much like a capacitance voltage divider for common mode pulses; the delta-delta connection, in particular, is exactly this, since there is no voltage across the windings in common mode.

The surge voltage ratio of secondary to primary in the delta-delta connection is given by

$$\mu = \frac{C_{12}}{C_{12} + C_{2g}}, \quad (8)$$

where  $C_{12}$  is the interwinding capacitance and  $C_{2g}$  is the secondary-to-ground capacitance. Since the primary is at a much higher voltage than the secondary, the insulation between primary and secondary is greater than that between secondary and ground. Hence,  $C_{2g}$  is ordinarily several times greater than  $C_{12}$ , and  $\mu$  is typically of the order of  $1/4$ . This has been demonstrated experimentally at IITRI using very fast pulses.<sup>13</sup> Lightning experience also bears this out.<sup>14</sup>

For pulses coupled onto the secondary, the transformer will pass them on to the primary according to Eq. (8), with  $C_{2g}$  replaced by  $C_{1g}$ . Typically,  $C_{1g}$  is of the same order of magnitude as  $C_{12}$ , and  $\mu$  is of the order of  $1/2$ .

Equation (8) suggests two ways to reduce the surge passed by transformers. The first is to reduce the value of the interwinding capacitance  $C_{12}$  by modifying the design of the transformer. The second is to increase the value of the secondary-to-ground capacitance  $C_{2g}$ . This may be effectively accomplished without redesigning the transformer by simply adding an external capacitance to ground on the secondary transformer terminals.

### 17.1.7 Results and Discussion

Voltages and currents for a number of typical geometries are shown in Figs. 17.4–17.11. The captions are self-explanatory.

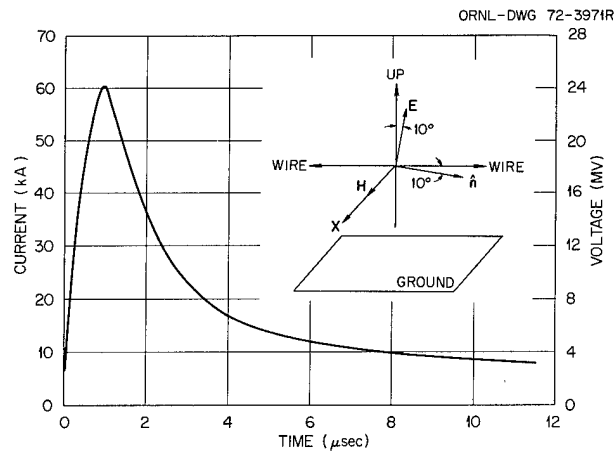

Fig. 17.4. The current induced in an infinite perfectly conducting wire according to scattering theory (pulse A of the text). The incident wave and its reflection are described in Fig. 17.2. The wire has a height of 10 m, a radius of 1 cm, and lies in the plane of incidence.

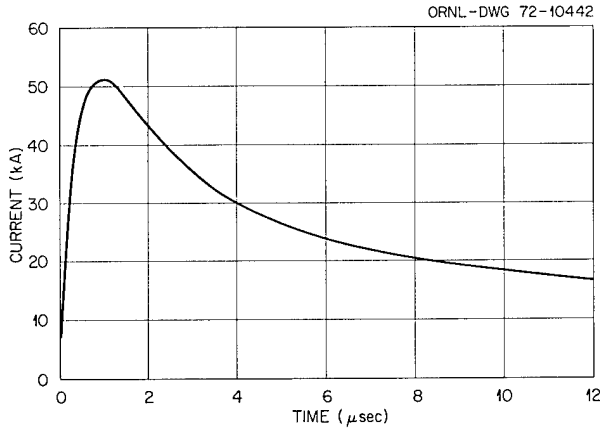

Fig. 17.5. The current for the same situation as described in Fig. 17.4 according to transmission line theory with no resistive element in the line or ground.

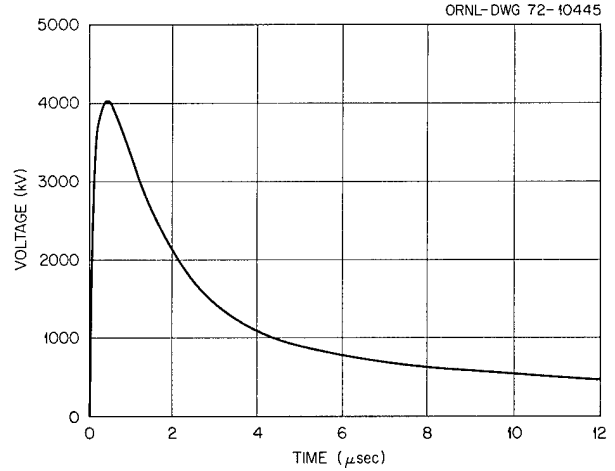

Fig. 17.8. The voltage corresponding to Fig. 17.7.

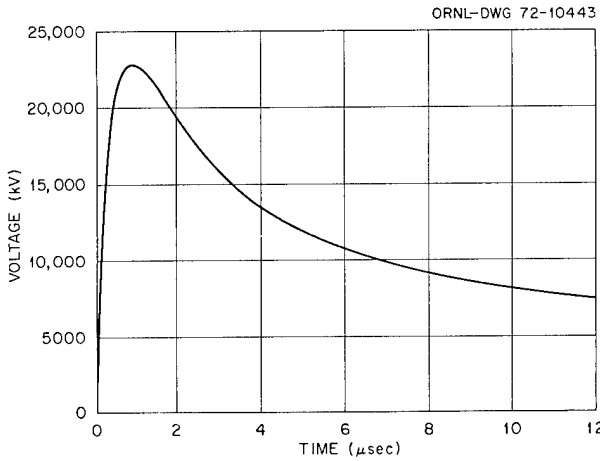

Fig. 17.6. The voltage corresponding to Fig. 17.5.

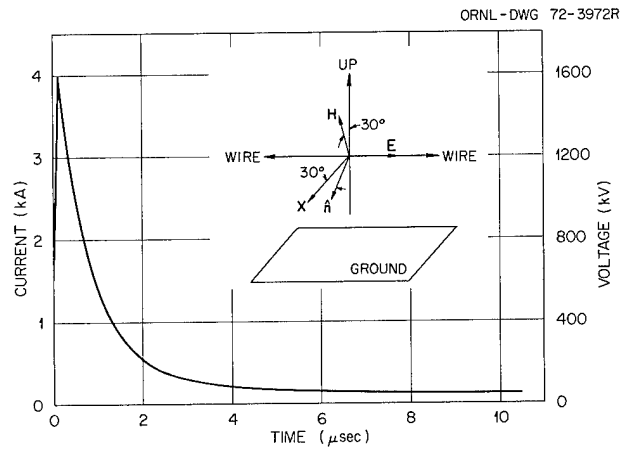

Fig. 17.9. The current in an infinite perfectly conducting wire according to scattering theory. The pulse is incident at an angle of  $60^\circ$  with the vertical, and the polarization is horizontal along the wire. (Pulse B of the text.)

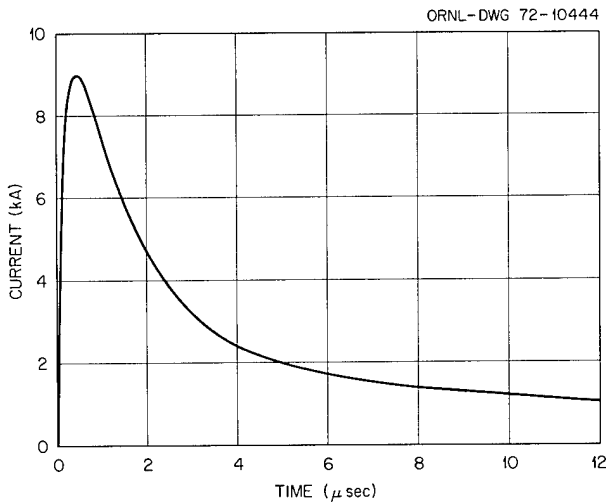

Fig. 17.7. The current as described in Fig. 17.5 but with frequency-dependent resistance included in line and ground.

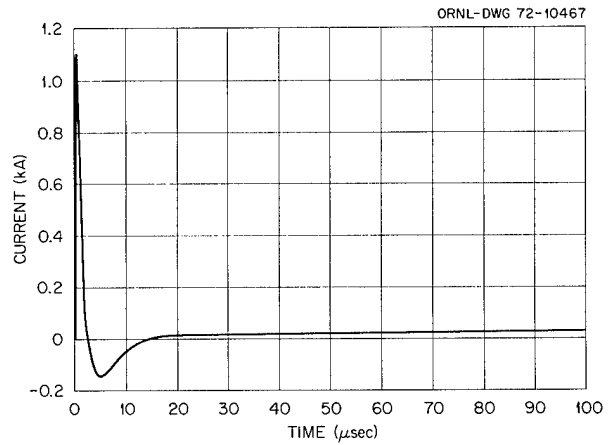

Fig. 17.10. The current (according to transmission line theory) in a semiinfinite copper wire over a resistive earth and terminated by an LC impedance  $\{Z = (2.1 + 0.0831s) / [1 + 1.05(10^{-8})s + 0.4155(10^{-9})s^2]\}$ . (Pulse C of the text.)

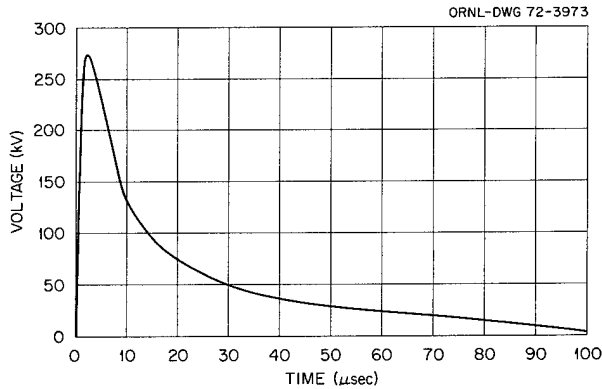

Fig. 17.11. The voltage corresponding to Fig. 17.10.

These results should be modified by a phenomenon which has not yet been taken into account, namely, that due to corona. This effect is quite significant for the large voltages we are considering. We hope to be able to include this in our calculations, although it will be more difficult, since this is a nonlinear effect. It is anticipated that the coronal modification of EMP-type pulses which are induced continuously along the line will be less significant than the coronal modification of lightning-type pulses which are induced more or less at a specific location on the line.

## 17.2 EMP EFFECTS IN POWER SUBSTATIONS

### 17.2.1 Introduction

During the past year an investigation of the EMP coupling to an electric power distribution system has been made. This is a continuation of studies reported last year.<sup>15</sup> To be specific, the Dixie substation of the Knoxville Utilities Board (KUB) was chosen as representing a typical substation. This substation connects the 66-kV sub-transmission system to the 13.8-kV distribution system.

The following substation apparatus must be protected against voltage transients: power transformers, instrument transformers, circuit breakers, disconnect switches, and buses. In the case of KUB's Dixie substation, all of the apparatus on the 66-kV side of the substation is insulated with respect to ground to a basic insulation level (BIL) of 350 kV and on the 13.8-kV side to a BIL of 110 kV. The BIL is the voltage the insulation will withstand on the application of the industry's standard pulse characterized by a rise time of 1.2  $\mu\text{sec}$  and a fall time of 50  $\mu\text{sec}$ . This standard has been chosen to represent a

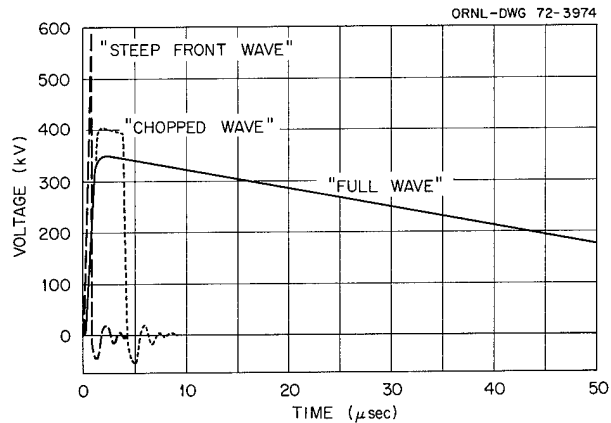

Fig. 17.12. The three standard test waves which a transformer must stand to have a BIL of 350 kV. (1) Full wave 1.25  $\times$  50  $\mu\text{sec}$ , (2) chopped wave, and (3) steep front wave.

lightning-induced pulse and is shown in Fig. 17.12 for a BIL of 350 kV.

To illustrate the methods used as well as to demonstrate the effects of EMP on the Dixie substation, we consider in turn the application to the 66-kV line of the voltages associated with the pulses shown in Figs. 17.4, 17.9, and 17.10. These are referred to in the following as pulse A, B, and C, respectively. Voltages are associated with pulses A and B by assuming a characteristic impedance of 400  $\Omega$ . The voltage for pulse C is obtained from Fig. 17.11. Voltage for pulse A is likely to occur only near the earth's magnetic equator. However, of the three pulses considered, pulse A produces the most severe stresses to the insulation of a 66-kV substation and is of interest for that reason. These EMP-type pulses should be compared with the lightning standard pulse shown in Fig. 17.12.

### 17.2.2 Protection by Lightning Arresters

The full magnitudes of EMP pulses will not be impressed upon the 350-kV insulation of the substation, since the station's 60-kV-rated lightning arresters will afford some protection. It is necessary to understand the nature of this protection.

Figure 17.13 is a plot of the standard station-type lightning arrester breakdown voltage in kilovolts per kilovolt of arrester rating. The arrester breakdown voltage may be defined as the voltage across the arrester terminals at the instant before the arrester spark gaps fire. The abscissa in this plot is the time between application of a voltage pulse to the arrester terminals and the onset of arrester breakdown.

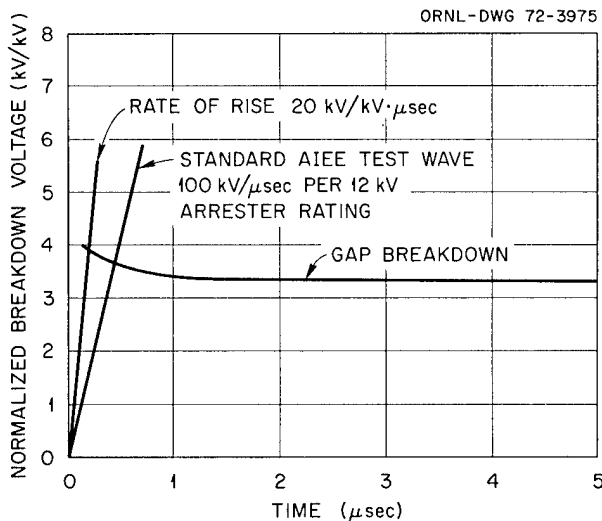

Fig. 17.13. Average impulse gap breakdown of station- and line-type arresters.

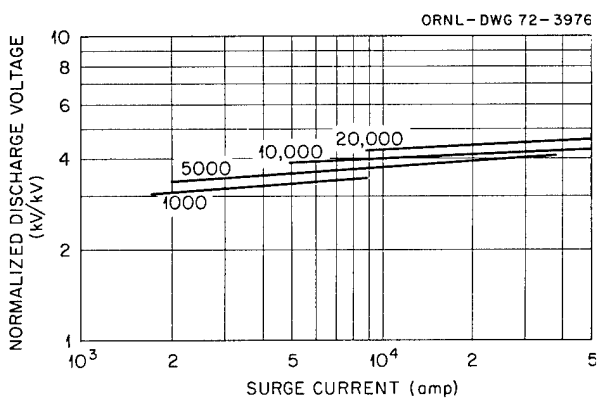

Fig. 17.14. Average discharge voltage characteristics of typical lightning arresters. Numbers on curves represent rate of rise of current in amperes per microsecond.

It is clear from the shape of the curve that larger pulses produce breakdown in shorter times. Similarly, Fig. 17.14 shows the discharge voltage, which is defined as that voltage across the lightning arrester terminals after the initial breakdown of the spark gaps and when the current limiting elements of the arrester are beginning to draw current. The discharge voltage depends upon both the current and its time rate of change.

Table 17.1 gives a comparison of crest values and slopes of the current and voltage associated with each of the three pulses. Using Figs. 17.13 and 17.14 (extrapolating where necessary) and Table 17.1, it is possible to arrive at estimates of the breakdown and discharge voltages expected on the

Table 17.1. Pulse parameters

Pulse	Maximum voltage (kV)	Maximum current (kA)	Average front slope voltage (kV/μs)	Average front slope current (kA/μs)
C	275	1.15	184	18.4
B	1,609	4.02	12,200	30.5
A	24,000	60.50	24,000	60.0

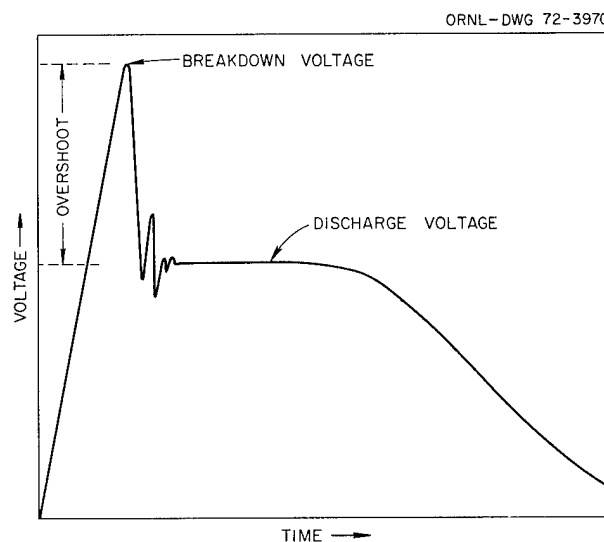

Fig. 17.15. Time history of voltage across a lightning arrester illustrating the distinction between breakdown voltage and discharge voltage in the situation where the magnitude of the former exceeds that of the latter.

60-kV-rated lightning arresters of the Dixie substation. The results are summarized in Table 17.2. Because of the high current and fast current rate of rise associated with pulse C, the lightning arrester discharge voltage exceeds the breakdown voltage. By contrast the rates of rise of the voltage in pulses A and B are so high that the breakdown voltage greatly exceeds the discharge voltage. The qualitative behavior of the voltage in this latter case is illustrated in Fig. 17.15. An exact analysis of the protection afforded against pulses A and B is not possible unless the presently available performance data for lightning arresters are extended by experiment to cover voltage pulses with rates of rise in excess of 1 MV/μsec.

The last column in Table 17.2 gives an upper limit on the energy expected to be discharged by the arrester. The industry standard for dissipation of energy by a lightning arrester is 4 kWsec per kV of arrester rating. It is clear that the 60-kV arresters

Table 17.2. Lightning arrester behavior

Pulse	Breakdown voltage (kV)	Discharge voltage (kV)	Time to reach breakdown voltage (nsec)	Energy dissipated (kWsec)
C	204	222	1000	1.20
B	438	246	30	0.35
A	534	330	10	22.8

used in the Dixie substation will easily dissipate the EMP energy coupled into the line for all three cases of interest.

### 17.2.3 Effect of Arrester Lead Length

In standard switching surge and lightning protection practice, the lightning arrester is placed between the incoming line and the substation to be protected. This practice also helps to protect against the effects of EMP, but, as in lightning protection, the length of the arrester electrical lead cannot be chosen arbitrarily. Because of the traveling wave nature of the EMP pulse on the power line, time is required for the pulse to travel down the arrester electrical lead, for the arrester to reach its breakdown voltage, and for this new voltage to travel back to the power line. If the arrester lead is too long, the protected apparatus has already been stressed to the full EMP voltage before the action of the arrester has affected the power line.

An analysis of the effect of the arrester lead length results in the following relation:

$$\frac{m}{x} = \frac{1}{t_0 c} \left( \sqrt{1 + \frac{4t_0 r}{E_0}} - 1 \right), \quad (9)$$

where  $m$  is the margin of protection defined as (apparatus withstand voltage minus arrester breakdown voltage)/arrester breakdown voltage,  $x$  is the length of the lightning arrester lead,  $t_0$  is a characteristic time of the lightning arrester,  $c$  is the velocity of light,  $E_0$  is the asymptotic (for large breakdown times) value of the breakdown voltage of the arrester, and  $r$  is the rate of rise of the applied EMP voltage. For station-type arresters  $t_0$  has a value of 35 nsec, and  $E_0$  has a value 3.4 times the arrester's rated voltage.

Equation (9) may be used to establish the protective level of existing lightning arresters or, given the expected EMP threat, to establish the maximum permissible arrester lead length in new construction.

Equation (9) gives the relationship between ( $m/x$ ) and  $r$  only in the case that the peak pulse voltage  $E_p$  exceeds the withstand voltage  $E_{max}$ . If this is not the situation, the following cases may be distinguished.

1.  $E_p < E_0$ . The lightning arrester fails to fire, and the protected point senses the full pulse.
2.  $E_0 < E_p < E_b(r)$ .  $E_b(r)$  is the arrester breakdown voltage and depends on  $r$ . In this case the lightning arrester fires after the peak voltage  $E_p$  has passed. The protected point senses a pulse which has been chopped on the tail and has peak voltage  $E_p$ .
3.  $E_b(r) < E_p < E_{max}$ . The lightning arrester fires. Depending upon length of the arrester lead, the protected point may sense any voltage between  $E_b(r)$  and  $E_p$ .

### 17.2.4 Circuit Breakers

Circuit breakers help protect substations from faults but not from the causes of faults. Thus, the circuit breakers will not protect a load from EMP but will only disconnect the load to remove a fault caused by EMP. Hence, this study is largely concerned with the EMP-induced faults across line and station insulation.

### 17.2.5 Station Insulation

According to Table 17.2 the circuit breakers, disconnect switches, and buses on the high-voltage side of the substation are protected against the effects of pulse C, since in this case the breakdown and discharge voltages of the arrester are less than the BIL of 350 kV. On the other hand, the arrester breakdown voltages for pulses A and B exceed 350 kV. Whether pulses A and B will cause the insulation to break down, however, is problematical because they are much shorter than the  $1.2 \times 50$  wave used to define the BIL. It is known that insulation will withstand high instantaneous voltages for short times (for example, the "steep front wave" discussed below); but, in the absence of quantitative data, no firm conclusions can yet be drawn concerning breakdown due to pulses A and B.

### 17.2.6 Transformers and Transformer Bushings

The voltage stresses inside transformers and bushings depend upon the shape of the wave impressed on the winding. In addition to the "full" wave used

to define the BIL (Fig. 17.12), transformers and bushings for use in 66-kV systems are also given a breakdown test with the "chopped" wave shown in Fig. 17.12. Because of the abrupt changes of voltage in the "chopped" wave, larger dielectric stresses are developed across the insulation of the transformer from it than from the "full" wave. Recently, manufacturers have also tested transformers of this class with a "steep front" wave as shown in Fig. 17.12. This "steep front" wave causes even more severe dielectric stresses than the "chopped" wave; and, because it rises with a slope of  $1 \text{ MV}/\mu\text{sec}$ , it more closely approximates the effects on transformers of EMP-type pulses A and B.

Simple lumped circuit models for transformers are poor approximations for calculating internal stresses from fast rising pulses, and the need for using distributed parameter circuits has long been recognized from experience with lightning.<sup>16</sup> In principle it should be possible to use these distributed parameter circuits for transformers under impulse conditions to compare the effects of the test waves in Fig. 17.12 with pulses A, B, and C, and thereby estimate the vulnerability of transformers to EMP. This, however, is not straightforward due to the lack of readily available circuit constants for transformers of interest. Despite the poor availability of numerical values for circuit theory parameters, systematic methods can be found for estimating some of the circuit parameters. But it should be remembered that the results of calculation will at best be approximate.

Figures 17.16, 17.17, and 17.18 show various voltages and currents, which can be expected according to distributed parameter circuit theory in windings

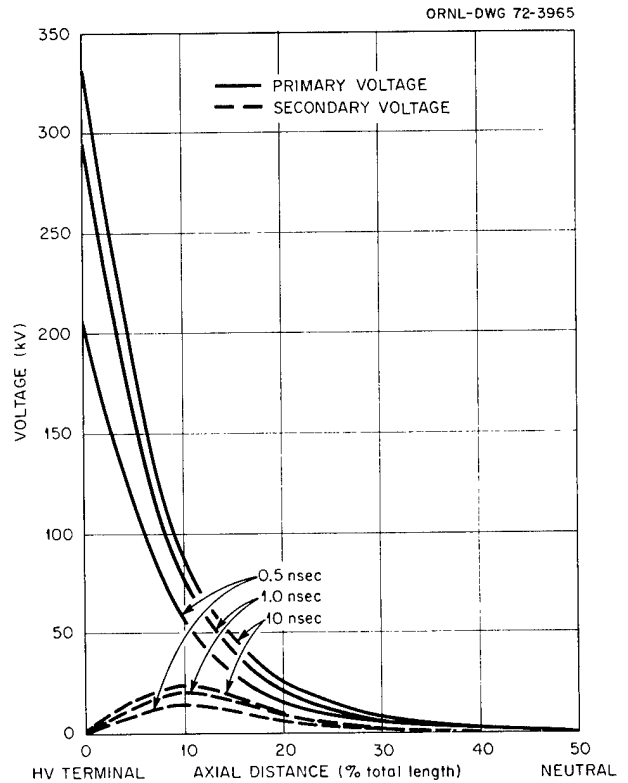

Fig. 17.16. Voltages in primary and secondary windings vs axial distance into winding for times of the order of the rise time of the applied pulse.

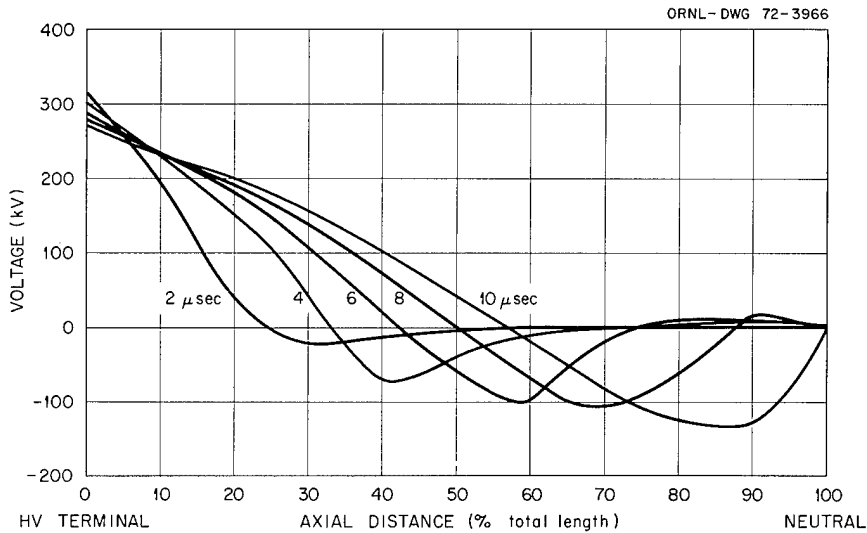

Fig. 17.17. Voltage in the primary winding vs axial distance into the winding for times of the order of the first natural period of the winding.

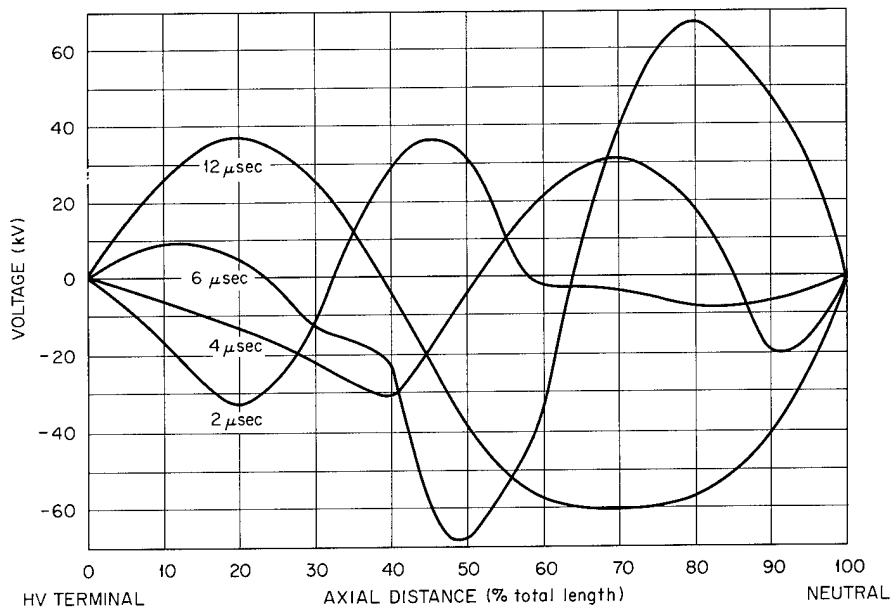

Fig. 17.18. Voltage in the secondary winding vs axial distance into the winding for times of the order of the first natural period of the winding.

of a single-phase transformer when stressed at the high-voltage terminal by a pulse with the discharge voltage of pulse A. The neutral of the primary winding and both of the terminals of the secondary winding of the transformer are assumed to be grounded. The pulse applied to the primary high-voltage terminal was assumed to rise to a peak of 330 kV in 10 nsec. This pulse only approximates the effect of the lightning arrester on pulse A; the large difference between the breakdown voltage and the discharge voltage has been ignored because the details of the transition of the voltage from breakdown to discharge were not known.

Figures 17.16, 17.17, and 17.18 show the spatial distribution of the voltage inside the primary and secondary windings at various times. The spatial coordinate is the distance along the axis of the winding. The zero of the spatial coordinate is assumed to be at the high-voltage terminal of the winding, with 100% of the winding having been traversed upon reaching the neutral. According to Fig. 17.16, the voltage applied to the high-voltage terminal does not distribute itself uniformly over the entire winding (at least for times of the order of the rise time of the pulse), but tends to pile up across the first 40% of the turns nearest the high-voltage terminal. Hence, the peak voltage of 330 kV is impressed upon the insulation of these first turns alone and, depending upon the insulation strength, could cause breakdown.

It is also apparent from the figure that the voltage transfer to the secondary is only a fraction of the applied voltage.

After the initial transients shown in Fig. 17.16 which propagate through the windings via their turn-to-turn capacitance and their capacitance to ground, oscillations are set up. This behavior is shown in Figs. 17.17 and 17.18. The oscillations become apparent only for times of the order of the first natural period of the windings which lies in the range of a few microseconds. By this time, currents are flowing in the winding leakage inductances, and the pulse applied to the high-voltage terminal is beginning to decay.

The presence of voltage oscillations indicates that this transformer model is imperfectly shielded against transients. Suppression of voltage oscillations is possible in actual transformers and should be encouraged to enhance the protection against EMP. Standard designs for reducing the oscillations use electrostatic shielding, interleaving of turns, layer windings, and graded capacitance. It may also be concluded by comparing pulse C with the three standard transformer test waves (Fig. 17.12) that if the transformer insulation will withstand the test waves, it will withstand pulse C also. Pulses A and B, however, because of their large rates of rise form another class and remain problematical. Efforts are being made to obtain better circuit constants, and at

such time it will be possible to compare pulses A and B with the three standard test waves and extend our conclusions.

### 17.2.7 Conclusions

We may safely conclude that any substation having a BIL of 350 kV or above will not suffer flashover of either station or transformer insulation from the application of pulse C. The effects of pulses A and B, however, remain problematical. In addition to transformer circuit parameters, lightning arrester breakdown voltage data for rates of rise of applied voltage in excess of 1 MV/ $\mu$ sec is essential if the effects of pulses A and B on station insulation or transformers is to be determined by comparison with lightning tests as discussed above.

### REFERENCES

1. J. W. Cooley and J. W. Tukey, "An Algorithm for the Machine Calculation of Complex Fourier Series," *Math. Comp.* **19**(90), 297–301 (1965).
2. A. H. Stroud and D. Secrest, *Gaussian Quadrature Formulas*, Prentice-Hall, Engelwood Cliffs, N.J., 1966.
3. V. I. Krylov and N. S. Skoklya, *Handbook of Numerical Inversion of Laplace Transforms*, Israeli Program for Scientific Translations, Jerusalem, 1969.
4. D. B. Nelson, "EMP Impact on U.S. Defenses," *Survive* **2**(6) (November–December 1969).
5. D. B. Nelson, *Effects of Nuclear EMP on AM Radio Broadcast Stations in the Emergency Broadcast System*, ORNL-TM-2830 (January 1971).
6. D. B. Nelson, H. P. Neff, and J. D. Tillman, "The Reflection of a Plane Electromagnetic Wave of Arbitrary Waveshape from a Plane, Homogeneous Earth," *IEEE Transactions on Antennas and Propagation*, March 1970.
7. J. H. Scott, "Electrical and Magnetic Properties of Rock and Soil," *Electromagnetic Pulse Theoretical Notes*, Air Force Weapons Laboratory, EMP 2-1, Vol. 1, Note 18, 1971.
8. J. A. Stratton, *Electromagnetic Theory*, McGraw-Hill, New York, 1941, pp. 492–94.
9. J. H. Marable, H. P. Neff, D. B. Nelson, and J. D. Tillman, "EMP Coupling Studies," *Annual Progress Report, Civil Defense Research Project, March 1970–March 1971*, ORNL-4679.
10. E. D. Sunde, *Earth Conduction Effects in Transmission Systems*, Dover, New York, 1968, Chap. 8.
11. Alan Greenwood, *Electrical Transients in Power Systems*, Wiley-Interscience, New York, 1971.
12. *Electrical Transmission and Distribution Reference Book*, Westinghouse Electric Corporation, East Pittsburgh, Pennsylvania, 1964.
13. E. Emerle and W. C. Emberson, private communication, February 16, 1972.
14. "Secondary Arresters Solve Lightning Problem," *Electrical Construction and Maintenance*, July 1966, pp. 124–25.
15. D. B. Nelson, "EMP Effects on Electric Power Systems," *Annual Progress Report, Civil Defense Research Project, March 1970–March 1971*, ORNL-4679.
16. L. V. Bewley, *Traveling Waves on Transmission Systems*, Dover, New York, 1963, Chap. 15.

## 18. Power Reactor Vulnerability

R. O. Chester C. V. Chester

### 18.1 CONSEQUENCES OF NUCLEAR WEAPON OVERPRESSURES GREATER THAN 20 PSI ON AN LMFBR

#### 18.1.1 Introduction

In previous studies,<sup>1,2</sup> it has been postulated that significant additional casualties from the fission product inventory of an LMFBR destroyed by a nuclear weapon will not be produced unless the inventory can be released in time to be added to the weapon fallout. In this study we examine the case in which the reactor is subjected to weapon overpressures below the range required to promptly eject the core from the reactor structure (about 175 atm), but in the range to destroy the reactor containment and the engineered safeguards (above about 20 psi). The reactor and containment are shown in Figs. 18.1 and 18.2.

In terms of the consequences, heavy damage to an LMFBR should be further subdivided into two categories: (1) the more severe, which we define as major, in which sufficient openings are made in the deck that air can get to the surface of the primary coolant, sodium, in the core tank and (2) the less severe, which we define as minor, in which the openings are sufficiently small that the space above the sodium surface is kept filled with sodium vapor. In the latter case, sodium vapor will vent through cracks and holes through the coolant pump and IHX penetrations, but flame from the burning sodium vapor will be kept above the deck and out of the sodium tank. The division between these two categories is uncertain, probably in the neighborhood of 200 psi, depending on construction details, direction of the burst, and size of the weapon.

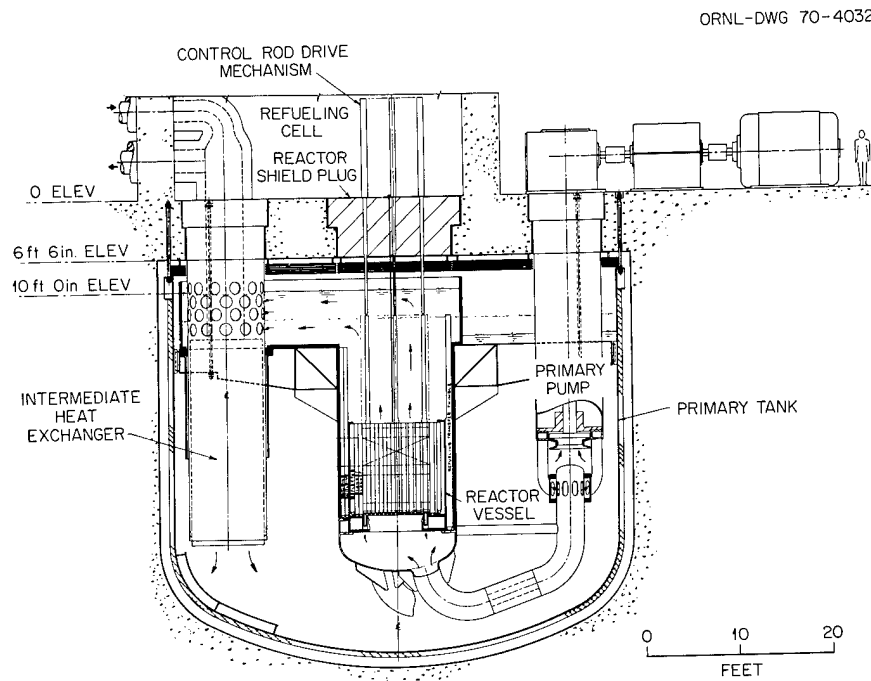

Fig. 18.1. Reactor and sodium tank, vertical section.

ORNL-DWG 70-4031

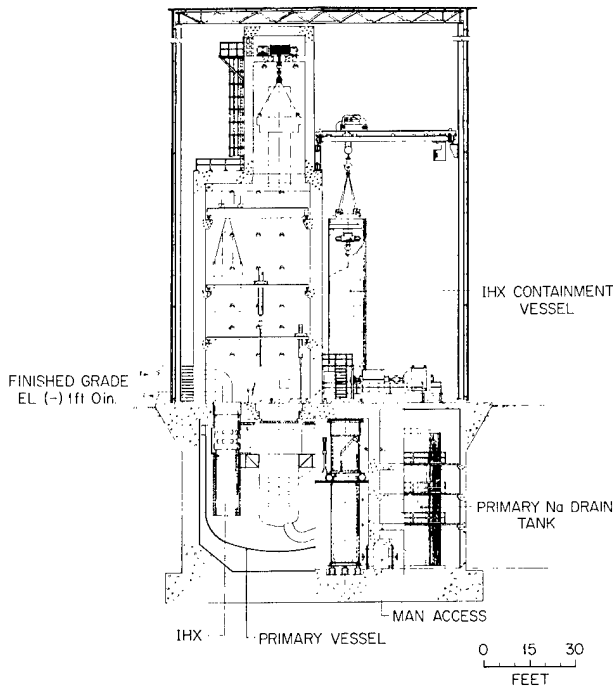

Fig. 18.2. Reactor containment building, vertical section.

### 18.1.2 Plant Description

The prototype for this study is the GE follow-on design, a "pot-type" LMFBR in which the core, primary coolant pumps, and intermediate heat exchangers are immersed in a 50-ft-diam by 40-ft-deep tank of liquid sodium. The tank is below-grade and covered by a 6-ft-thick concrete deck designed to contain the core in the event of a core explosion releasing something less than a ton of TNT-equivalent mechanical work. Part of the deck is covered by the refueling cell, a 70-ft-high structure with 4-ft-thick walls. The intermediate heat exchangers are inside the refueling cell in some designs and outside in others. Most designs call for these items to be mounted on removable plugs for quick replacement. The IHX plugs have the inlet and outlet sodium lines coaxial with their centers and probably are the items most susceptible to breaching by weapons effects.

#### 18.1.3 Sequence of Events: Low Overpressures

At low overpressures (20 to 200 psi) the containment building over the reactor will be blown away, along

with all the electrical systems supplying power to all the coolant pumps. The loss of power should scram the reactor.

If debris or distortion blocks flow through the core, the sodium in the core will boil in seconds to minutes, depending on the power level when the reactor was scrammed. The core will begin to melt in minutes, releasing the noble gases, iodine, and cesium. The iodine, cesium, xenon, and rubidium will dissolve in the sodium. The noble gases will leak out through a combination of seals sprung by the blast and pipes and fittings of the argon system broken off by the blast or flying debris. The alkaline earths, rare earths, and actinides will largely remain in the  $\text{UO}_2\text{-PuO}_2$  fuel.

At this level of damage, any nuclear excursions produced by the collapsing core should be contained by the structure. The particulates produced by fuel vaporization should be retained in the sodium.

The fission product decay heat will heat the  $3 \times 10^6$  lb of primary sodium from its operating temperature ( $430^\circ\text{C}$ ) to boiling ( $914^\circ\text{C}$  at 1 atm) in about 13 hr, and will boil it away in about 120 more hours. If not previously damaged, the core will melt during this time. Experimental evidence<sup>1-3</sup> indicates that the cesium will be released during the first few hours after meltdown, but the sodium iodide will distill off at about the same rate as the sodium.<sup>6</sup> After the sodium is all boiled away, the core will melt its way into the concrete in the bottom of the tank, covering itself with a layer of melted stainless steel and slag. The  $\text{UO}_2\text{-PuO}_2$  fuel will continue to melt into the ground until dilution and decay of the fission products reduce the heat flux to a value that can be conducted away by the ground.

#### 18.1.4 Sequence of Events: High Overpressures

At some value of overpressure in the low hundreds of psi, there is a qualitative change in the sequence of events. At this level, which depends also on orientation of the structure to the burst, major openings will be produced in the primary containment. Probably the first such will be through the IHX's. The dynamic loads on the 34-in. secondary coolant lines will develop bending moments leading to failure where they enter the primary containment. At the same time, the hydrostatic pressure in this coolant could burst the IHX shell in the sodium tank.

Also, at about this overpressure, the refueling cell wall facing the weapon will be sheared off and sweep through the control rod drives on the core plug. If the pressure accelerating the wall is greater than 400 psi

(which can be produced by reflection of an 85-psi shock), the drives can all be either bent over or sheared off in 100 msec by the cell wall closest to the core plug. Since there is a 150-msec delay in initiating a scram, and since about 250 msec are required for travel of the scram rods, the reactor will not be scrammed when the primary coolant circulation is stopped. This will result in very rapid vaporization and voiding of the sodium in the core, producing a reactivity insertion of about 70 dollars per second.<sup>4</sup> The critical excursion will terminate with the release of about 200 MWsec of energy, which will vaporize about 1% of the core. Most of this vapor will vent out of the primary containment through the openings made by the nuclear weapon. This initial puff, which is a potential respiratory hazard, will be released into the afterwinds of a 1-megaton surface or low air burst, within about 1/2 mile of ground zero. The afterwinds will carry the puff into the rising thermal column of the weapon and several thousand feet up. If this material returns to the surface, it will be mixed with the early fallout. Therefore, whether or not a critical disassembly incident occurs, the results presented here should not be materially changed.

In any event, further fission product release should occur after the weapon effects have subsided. Briefly, the sequence of events is (1) some of the fission products diffuse into the sodium, and (2) when the sodium burns we assume that some of these fission products are incorporated in the sodium oxide aerosol and carried downwind by local meteorological conditions.

In the minor damage region, only those fission products that are entrained by the sodium vapor are transported outside the power plant area. In addition, the GE system description indicates that it takes approximately 13 hr from a full-power shutdown with loss of intermediate cooling systems for the 3 million pounds of sodium in the tank to be brought to a boil by fission product heating. Since major fission product release from the fuel does not occur until the sodium boils, the fission products released will be 13 hr old.

In the major damage region, the surface of the sodium is burning, and some of the heat of combustion will heat the liquid sodium so that the time to reach boiling may be decreased to 6 or 7 hr. We assume in this case that all those fission products dissolved in the sodium are incorporated into the sodium oxide particles.

The second column in Table 18.1 gives the fraction of each fission product assumed to escape the UO<sub>2</sub> and to remain uniformly distributed in the sodium while it is boiling. These numbers are taken from data reported by Descamps.<sup>9</sup> He melted trace-irradiated UO<sub>2</sub> in an inert

Table 18.1. Fission products released from LMFBFR

Fission product	Percent in Na <sub>2</sub> O aerosol	Percent distilled with sodium	Soluble in dilute NaOH
Br	100.0	100.0	Sol
Rb	100.0	100.0	Sol
Sr	1.2		Sol
Zr	0.13		
Ru	2.9		
Rh	2.9		
Pd	2.9		
Te	8.9	8.9	
I	100.0	100.0	Sol
Cs	100.0	100.0	Sol
Ba	0.21		
Ce	0.09		
Pr	0.09		
Nd	0.09		
Pm	0.09		

atmosphere and admitted air just before jetting sodium into the molten UO<sub>2</sub>. The fraction of the fission products in the sodium oxide aerosol was determined. This second column gives the total fraction of the core fission products released over the length of time it takes the sodium to burn in the event that the reactor has major damage to the primary containment. Column 3 gives the fraction that distills with the sodium vapor. This column is from calculations and some data by Castleman<sup>10</sup> and Baumash.<sup>1</sup> Very little experimental data are available that apply to these situations, and future data may markedly change these results. Column 4 indicates the fission product oxides that are soluble in dilute sodium hydroxide. The sodium oxide associated with the fission products should produce sodium hydroxide upon contacting the moist lung surface, and the soluble fission products should be readily absorbed. Overall, this table shows that a very small fraction of the core fission products are released.

Our inhaled dose estimation shows that iodine is by far the most serious hazard. Essentially all the inhaled iodine collects rapidly in the thyroid and is released with a relatively long half-life (138 days). So a small vital organ receives all the damage from the radioactive iodine. If the radiation damage is enough to permanently destroy the functioning of the thyroid, the condition is called thyroid burnout. Without administration of thyroxin on a regular basis, thyroid burnout is fatal.

## 18.2 DOSE CALCULATION FOR AREAS UNDAMAGED BY WEAPON OVERPRESSURE

Using burn rate data for sodium observed by Koontz,<sup>6</sup> we estimate that it should take the sodium in the tank approximately a week to burn away. The inhalation dose during this period is obviously a strong function of the meteorological conditions during this week. The problem is then to give a realistic and conservative estimate of the inhalation dose without grossly overstating or underestimating the hazard. For example, a gross overstatement of the problem is obtained by assuming that the worst possible meteorological condition persists over the entire release period. An underestimate of the maximum hazard is obtained by assuming that the year's average meteorological conditions are representative of the conditions during the release period. By using a number of realistic but worst meteorological conditions, we tried to obtain an estimate of the maximum hazard of an LMFBR in a target area.

With the assistance of Frank Gifford and Walter Culkowski of the National Oceanic and Atmospheric Administration, the meteorological data taken at the Tower Shielding Facility from 1963 thru 1967 were examined. Data from this facility were used because the station is 300 ft above the ground surface and more nearly approximates the conditions at the plume stabilization heights. The meteorological data for the ten weeks when the wind persisted longest in one direction were extracted and compared with the average meteorological data. Figure 18.3 shows a condensation of these data. For a given wind speed and day or night condition, there are usually several turbulence types and plume stabilization heights possible, depending on the amount of overcast or insolation and temperature gradient.<sup>5,7,8</sup> To avoid underestimating the hazard, for each set of possible turbulence types and plume stabilization heights, those that gave the greatest inhalation dose were used.

Figure 18.4 shows the results of estimating the inhalation dose for the week ended March 9, 1967. This week provided the most severe hazard of any of those pictured in Fig. 18.3. The map of the Oak Ridge area is added to give a realistic perspective to the distances involved. To put the reactor hazard in perspective, the weapons effects of an airburst 1-megaton weapon are

plotted. At distances less than 18 km from ground zero unprotected people receive at least second degree burns, which can be serious if the face or large areas of the body are involved. Less than 10 km from ground zero, third degree burns, which are usually fatal, are received by unsheltered people. Four psi at 5 to 6 km is often assumed as the midlethal overpressure for unwarned people in light frame houses; flying glass and debris usually cause the casualties.

The inhalation dose is plotted for people who stay in one place for the entire release period with no improvised face masks and no prophylactic iodine treatment. The iodine released from the LMFBR meltdown is all in the form of sodium iodide, an easily filtered particulate as contrasted with some of the organic iodides. As a result, improvised face masks can provide perhaps a factor of 10 reduction in the inhaled dose. Such a reduction removes the possibility of thyroid burnout outside the 4-psi circle. If prophylactic iodide treatment were administered the dose to the thyroid could be reduced by a factor of 100.

The inhalation dose from this week and one other worst week are presented in Fig. 18.5 for both minor and major damage to the reactor primary containment. The smaller patterns for minor damage to the containment are due to fewer fission products being released and the longer delay before the sodium gets up to boiling. All the remaining eight worst meteorological conditions produce only possible, not probable, thyroid burnout and no possible 400-R whole-body dose outside the 4-psi region. Using the year's average meteorological conditions, not even possible thyroid burnout is produced outside the 4-psi region.

These dose patterns have been drawn assuming an airburst weapon. For overpressures at the reactor of much more than 200 psi, the weapon must be detonated near enough to the surface that its early fallout cannot be neglected. Figure 18.6 compares the dose from a 1-megaton fission weapon fallout and the reactor fission products. Within the contour line 400 R or more is received, which is sometimes considered a midlethal whole-body dose.

From this and previous work we conclude that the presence of an LMFBR in a nuclear weapon target area does not produce a militarily significant number of additional casualties.

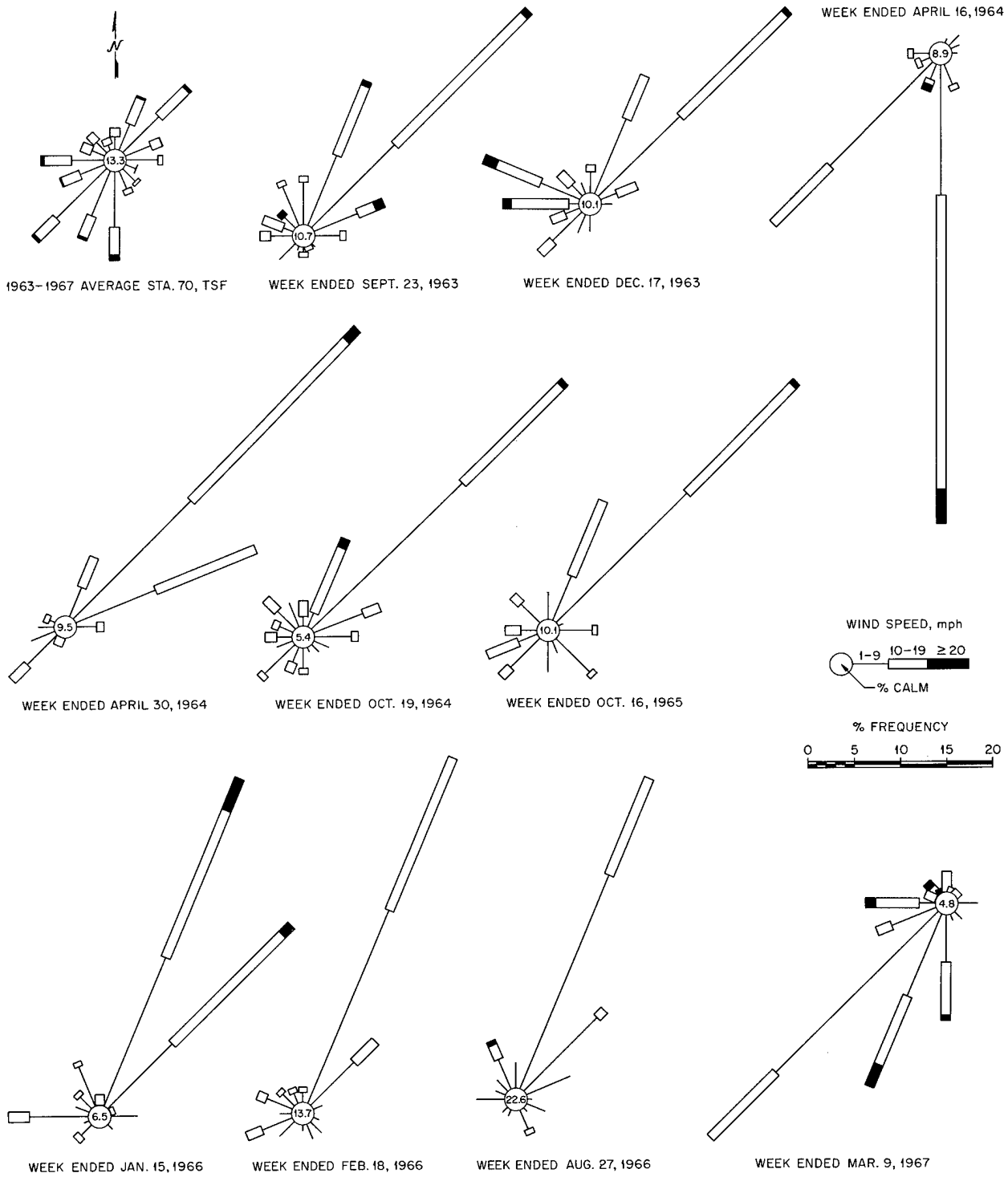

Fig. 18.3. Tower shielding facility wind distributions.

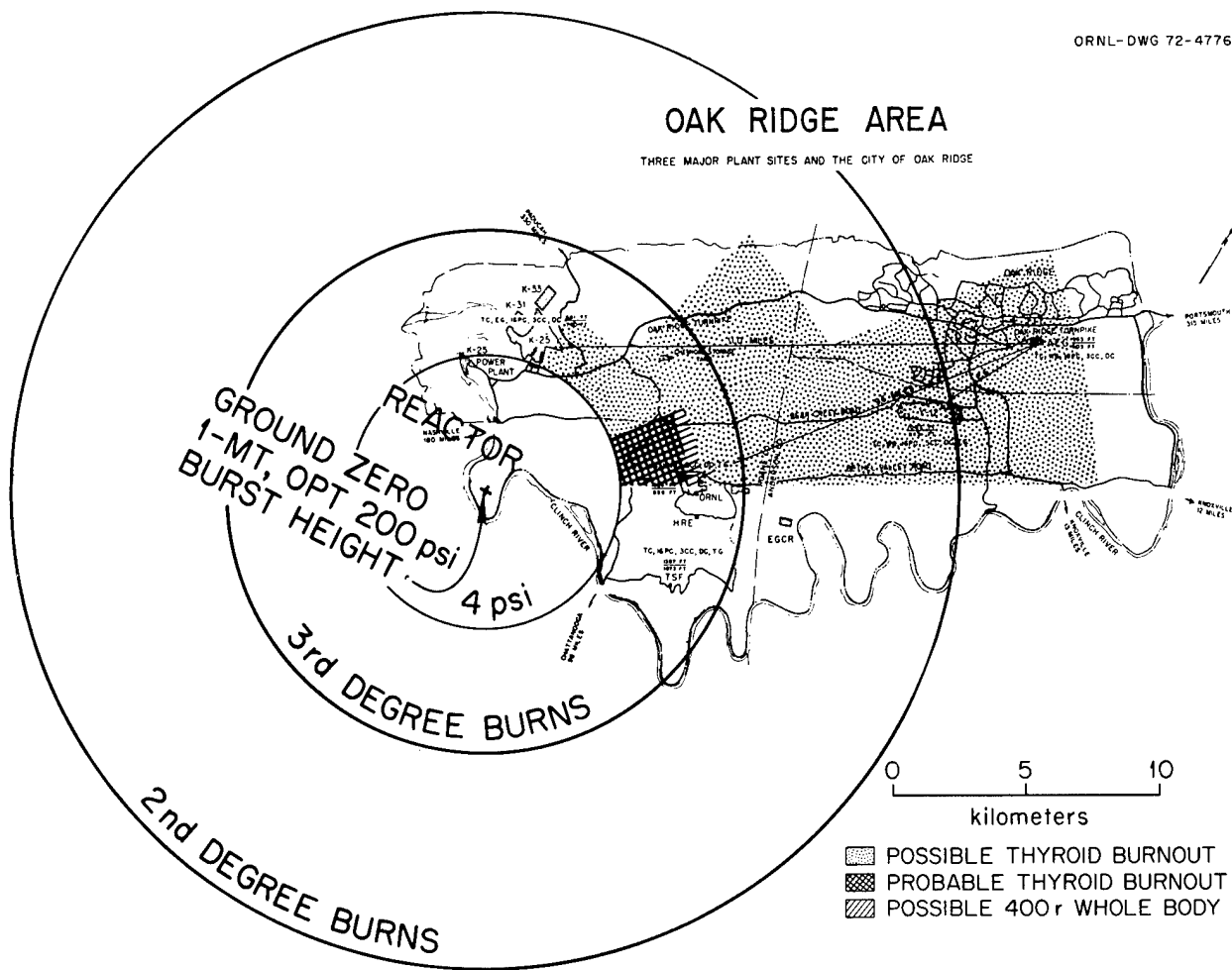

Fig. 18.4. Reactor meltdown and weapon effects.

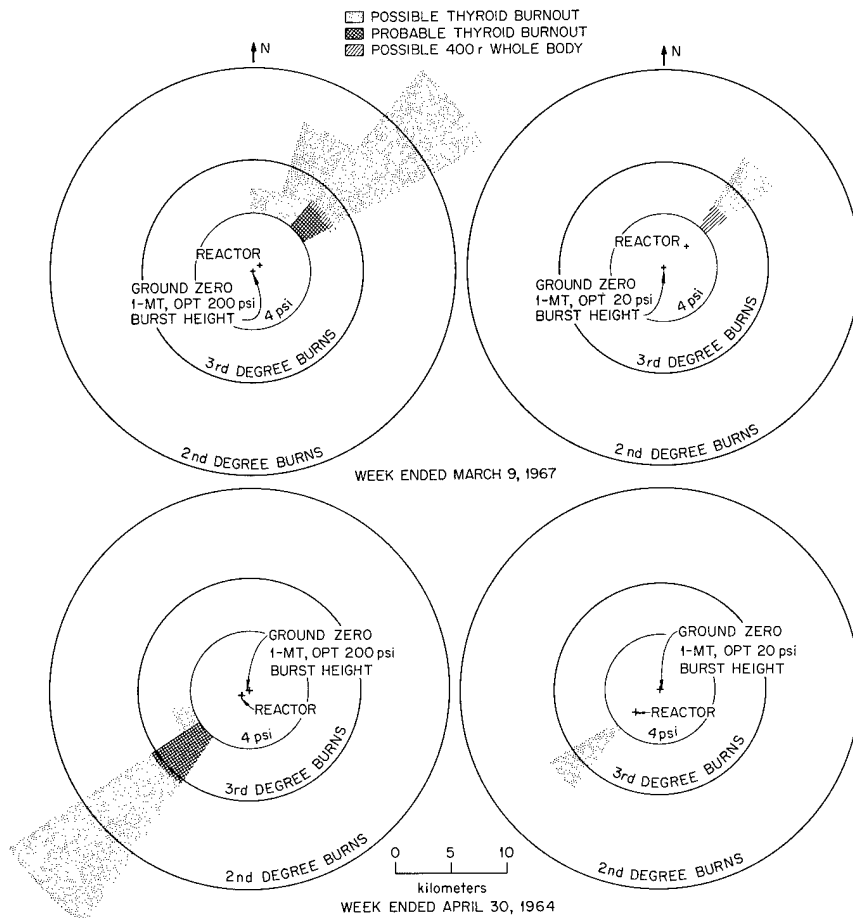

Fig. 18.5. Reactor fission product release.

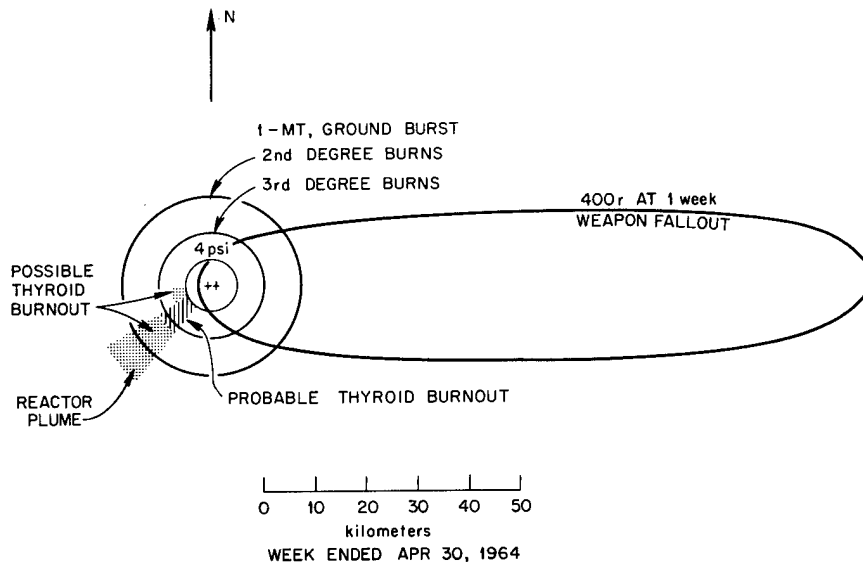

Fig. 18.6. Reactor fission products and weapon effects.

## REFERENCES

1. L. Baumash, C. Nelson, J. Granger, and R. Koontz (Atomics International), "Behavior of Iodine in the Presence of Sodium Oxide Aerosols," *Proc. 11th AEC Air Cleaning Conference*, Conf 700816, CFSTI, Springfield, Va., December 1970, p. 373.
2. A. S. Goldin, H. A. Trindale, S. H. Lee, and M. W. First, "Behavior of Iodine in Sodium Systems," *Ibid*, p. 356.
3. W. S. Clough, S. W. Wade, and H. Aere, "Caesium Behavior in Liquid Sodium — the Effect of Carbon," *Ibid*, p. 393.
4. D. E. Simpson, J. W. Hagan, A. E. Walter, R. A. Harris, A. Padilla, and G. L. Fox, *Preliminary Analysis of Postulated Maximum Accidents for the FFTF*, BNWL-760 (November 1968).
5. G. A. Briggs, *Plume Rise*, U.S. Atomic Energy Commission, TID-25075 (1969).
6. R. L. Koontz, C. T. Nelson, L. Baumash, and R. P. Johnson, "Large-Scale Sodium Aerosol Experiments," *TransANS* 12(1), 331 (1969).
7. Franklin A. Gifford, Jr., "An Outline of Theories of Diffusion in the Lower Layers of the Atmosphere," *Meteorology and Atomic Energy 1968*, U.S. Atomic Energy Commission, TID-24190, 1968, pp. 65–105.
8. G. A. Briggs, I. Van der Hoven, R. J. Engelmann, and J. Halitsky, *Processes Other Than Natural Turbulence Affecting Effluent Concentration*, U.S. Atomic Energy Commission, TID-24190, 1968, pp. 189–252.
9. C. Descamps, C. Beaudet, and J. Rygaert, "Behavior of Several Fission Products in the Atmosphere Surrounding Sodium-Cooled Reactors in the Event of a Major Accident," *Proceedings of the International Conference on Sodium Technology and Large Fast Reactor Design*, Nov. 7–9, 1968, ANL-7520, Pt. I.
10. A. W. Castleman, Jr., and G. C. Lindauer, *A Review of the Current Status of Research on the Chemical and Physical Aspects of Liquid-Metal-Cooled Fast Breeder Reactor Safety. II. Aerosols*, BNL-14911 (June 1970).

## Publications

### MARCH 1971–MARCH 1972

- Annual Progress Report, Civil Defense Research Project, March 1970–March 1971*, ORNL-4679.
- W. J. Boegly, Jr., and W. L. Griffith, "Underground Utility Tunnels," *Mechanical Engineering*, September 1971.
- R. A. Bohm and D. A. Patterson, "Interstate Highways and the Growth and Distribution of Population," *Proceedings of the American Statistical Association Conference*, Fort Collins, Colorado, August 23–26, 1971.
- M. M. Clarke, *Black-White Ghettos: Quality of Life in the Atlanta Inner City*, ORNL-HUD-25 (December 1971).
- M. M. Clarke and C. Clarke, *Environmental Variables Affecting Child Development*, ORNL-HUD-7 (June 1971).
- G. A. Cristy, *Blast Shelter Potential in New Government Buildings*, ORNL-TM-3664 (December 1971).
- G. A. Cristy, *Transportation Systems and Dual Purpose Blast Shelters: Final Report*, ORNL-4675 (October 1971).
- J. S. Gailar, "Soviet 'Assured Survival' – A Rural Plan," *Survive* 4(3), 8–11 (May-June 1971).
- C. H. Kearny, "High-Protection-Factor Hasty Rural Shelters," *Survive* 4(4), 7–9 (July-August 1971).
- C. H. Kearny, *More Efficient Operation of Kearny Air Pumps for Manual Ventilation of Shelters*, ORNL-TM-3562 (September 1971).
- E. S. Lee, "Trends in Growth," *President's First Biennial Report on National Growth, 1972*, U.S. Government Printing Office, Washington, D.C., February 1972.
- E. S. Lee, A. S. Lee, and K. P. Nelson, "Conventional Wisdom and Population Distribution Policy," *Annual Meeting of the Population Association of America*, Washington, D.C., April 1971.
- E. S. Lee, J. C. Bresee, K. P. Nelson, and D. A. Patterson, *An Introduction to Urban Decentralization Research*, ORNL-HUD-3 (June 1971).
- E. S. Lee, M. L. Levin, W. W. Pendleton, and P. D. Postma, *Demographic Profiles of the United States*, ORNL-HUD-24: Vol. I – "The Nation, Regions, Divisions, and States," September 1971; Vol. II – "New England and the Middle Atlantic States," December 1971; Vol. III – "The East North Central States," February 1972; Vol. IV – "The West North Central States," February 1972; Vol. V – "The South Atlantic States," February 1972.
- J. H. Marable and M. Tobias, "An Observation on the Material Bucklings of the Multigroup Diffusion Equations," *Nucl. Sci. Eng.* 45, 86 (1971).
- J. R. Moore, *Centripetal and Centrifugal Forces in the American Economy*, ORNL-HUD-8 (November 1971).
- K. P. Nelson, "Labor Mobility: An Analysis of Social Security Data for Atlanta," *Proceedings of the American Statistical Association Conference*, Fort Collins, Colorado, August 1971.
- I. M. Newman, *Infant Mortality as a Potential Measure of Community Health in Urban Growth*, ORNL-HUD-10 (June 1971).
- C. E. Patterson, Jr., *The New Towns Movement*, ORNL-HUD-9 (August 1971).
- A. W. Stuart, *Rural Industrialization and Population Growth: The Case of Arkansas*, ORNL-HUD-4 (June 1971).

*INTERNAL DISTRIBUTION*

1. Biology Library
- 2–4. Central Research Library
- 5–179. Civil Defense Project Library
180. ORNL – Y-12 Technical Library  
Document Reference Section
- 181–215. Laboratory Records Department
216. Laboratory Records, ORNL R.C.
217. R. J. Allen
218. S. I. Auerbach
219. J. A. Auxier
220. J. K. Baird
221. R. J. Barnard
222. P. R. Barnes
223. S. E. Beall
224. B. L. Bishop
225. W. J. Boegly, Jr.
226. R. A. Bohm
227. C. B. Brooks
228. F. R. Bruce
229. N. A. Buhl
230. T. J. Burnett
231. C. V. Chester
232. R. O. Chester
233. K. E. Cowser
234. C. W. Craven
235. G. A. Cristy
236. F. L. Culler, Jr.
237. L. Dresner
238. J. L. Fowler
239. A. P. Fraas
240. J. S. Gailar
241. J. H. Gibbons
242. N. B. Gove
243. W. L. Griffith
244. C. M. Haaland
245. R. F. Hibbs
246. E. A. Hirst
247. G. R. Jasny (Y-12)
248. W. H. Jordan
249. C. H. Kearny
250. S. M. Kelly
251. R. E. Kemper
252. D. M. Lang
253. E. S. Lee
254. M. L. Levin
255. J. L. Liverman
256. W. C. McClain
257. N. S. Malthouse
258. J. H. Marable
259. R. W. Manweiler
260. A. J. Miller
261. C. Nader
262. D. B. Nelson
263. K. P. Nelson
264. R. J. Olsen
- 265–267. R. B. Parker
268. C. H. Patrick (K-25)
269. F. S. Patton
270. W. W. Pendleton
271. P. D. Postma
272. D. E. Reichle
273. P. N. Ritchey
274. R. C. Rosenvinge (Y-12)
275. D. R. Sears (Y-12)
276. M. J. Skinner
277. R. D. Smith (Y-12)
278. W. S. Snyder
279. R. Spore
280. E. G. Struxness
281. D. A. Sundberg
282. R. C. Taeuber
283. J. R. Totter
284. D. B. Trauger
285. W. C. Ulrich
286. G. U. Ulrikson
287. A. C. Upton
288. A. M. Weinberg
289. E. P. Wigner
290. M. M. Williams
291. G. Young

*EXTERNAL DISTRIBUTION*

292. Dr. Harold M. Agnew, Director, Los Alamos Scientific Laboratory, Los Alamos, New Mexico 87544
293. Edward L. Alexander, Dean of the Graduate School, Lowell Technological Institute, Lowell, Massachusetts 08154
294. John W. Anderson, Jr., Executive Director, East Tennessee Development District, 1810 Lake Avenue, Knoxville, Tennessee 37916
295. Gould Andrews, ORAU, Oak Ridge, Tennessee 37830
296. Architectural and Engineering Development Information Center for Divil Defense, Attn: Mrs. Jane Leatherwood, Librarian, University of Florida, Gainesville, Florida 32601
297. Army Nuclear Defense Laboratory, Technical Library, Edgewood, Maryland
298. Army War College, Library, Fort McNair, Washington, D.C.
299. Assistant Secretary of the Air Force (R and D), Room 4E968, Pentagon, Washington, D.C. 20330
300. Assistant Secretary of the Army (R and D), Attn. Assistant for Research, Washington, D.C. 20310
301. Captain John O. Bachert, U.S. Navy, Department of Defense, National Military Command System Support Center, B-200, Washington, D.C. 20301
302. Philip J. Bailey, Director, County of La Salle – Office of Civil Defense, La Salle County Court House, Ottawa, Illinois 61350
303. Robert E. Bailey, Nuclear Engineering Department, Purdue University, Lafayette, Indiana 47907
304. Mr. Raymond J. Barbuti, Deputy Director, Office of Natural Disaster and Civil Defense N.Y. State Department of Transportation, Bldg. 22, State Office Bldg. Campus, Albany, New York 12226
305. Raymond Bauer, Harvard University, Graduate School of Business Administration, Soldiers Field, Boston, Massachusetts 02163
306. Carl Baum, AFWL/ESE, Kirtland AFB, New Mexico 87117
307. Calvin L. Beale, 1960 Biltmore Street, N.W., Washington, D.C.
308. Ira C. Bechtold, 1987 Skyline Vista Drive, La Habra, California 90631
309. M. C. Bell, University of Tennessee, 205 Animal Science Building, Knoxville, Tennessee
310. Mayhue A. Bell, AEC, Operational Safety Division, Germantown, Md.
311. Thomas L. Bell, Department of Geography, University of Tennessee, Knoxville, Tennessee 37916
312. Louis J. Belliveau, Defense Nuclear Agency, Department of Defense, Washington, D.C. 20305
313. Calvin Belote, SRI, Huntsville, Alabama
314. David Benson, Postattack Research Division, Office of Civil Defense, Pentagon, Washington, D.C.
315. Major Nolond J. Benson, Executive Assistant, Office of Emergency Planning, National Guard Armory, Sidco Drive, Nashville, Tennessee
316. John Beresford, Director, DUALabs, Suite 900, 1601 N. Kent Street, Rosslyn, Virginia 22209
317. Brian J. L. Berry, P.O. Box 190, Park Forest, Illinois
318. Donald A. Bettge, Research Directorate, Defense Civil Preparedness Agency, Room 1D538, The Pentagon, Washington, D.C. 20301
319. Lt. Gen A. W. Betts, Chief, Research and Development, Department of the Army, Washington, D.C.
320. Michael Betz, Department of Sociology, 919 McClung Tower, University of Tennessee, Knoxville, Tennessee 37916
321. I. H. Billick, Deputy Director, Environmental Quality Control, Housing and Urban Development, Washington, D.C.
322. Dr. George F. Bing, Lawrence Livermore Laboratory, P.O. Box 808, Livermore, California 94550
323. David L. Birch, Harvard Business School, Soldier's Field, Massachusetts 92163
324. Marie Blaylock, Research Assistant, Carolina Population Center, University Square, Chapel Hill, North Carolina, 27514
325. D. B. Bobrow, Director, Center for International Relations, Social Science Building, Room 1246, University of Minnesota, Minneapolis, Minnesota 55455
326. Robert A. Bohm, Department of Finance, 415 Alumni Hall, University of Tennessee, Knoxville, Tennessee 37916

327. Gladys K. Bowles, Institute for Behavioral Research, University of Georgia, Athens, Georgia 30601
328. Eleanor Boyles, Librarian, School of Police Administration, Michigan State University, East Lansing, Michigan
329. John F. Bradley, Defense Programs Branch, Transportation & Warehouse Div., Consumer & Marketing Service, U.S. Dept. of Agriculture, Rm. 503, Pomponio Plaza, Washington, D.C. 20250
330. Lloyd M. Braff, 910 Gulf States Building, Dallas, Texas 75201
331. Edward Bramlitt, DA/05A/OCD(TS), Room 1C535, The Pentagon, Washington, D.C. 20310
332. John E. Brantley, Civil Defense Office, 94 Arkansas Avenue, Oak Ridge, Tennessee
333. C. D. Breinig, 561 U.S. Court House, Nashville, Tennessee 37203
334. Dr. James C. Bresee, Assistant Director for General Energy Development, Division of Applied Technology, USAEC, Washington, D.C. 20545
335. Peter Brewer, Agricultural Engineer, North Dakota State University, Fargo, North Dakota
336. Jack Bridges, IIT Research Institute, 10 West 35th Street, Chicago, Ill. 60616
337. Dr. Robert Brock, Office of Emergency Preparedness, Executive Office of the President, Washington, D.C. 20504
338. H. L. Brode, Rand Corporation, 1700 Main Street, Santa Monica, California 90406
339. Stephen L. Brown, Stanford Research Institute, Palo Alto, California
340. William M. Brown, Research Consultant, 19709 West Horseshoe Drive, Topanga, California 90290
341. Arthur Broyles, Department of Physics, University of Florida, Gainesville, Florida 32601
342. James O. Buchanan, DCPA, Washington, D.C. 20301
343. Zolin Burson, EG&G, P.O. Box 1912, Las Vegas, Nevada 89109
- 344-345. Neil Carter, Office In Charge, Consumer Marketing Service, USDA Room 409, Federal Building, Memphis, Tennessee 38103
346. Arthur D. Caster, Chairman, Coordinating Committee on Civil Defense, American Society of Civil Engineers, 2864 McFarlan Park Drive, Cincinnati, Ohio 45211
347. LTC Gerald W. Chase, Office of the Chief of Engineers, Department of the Army, Washington, D.C. 20314
348. Eric Chetwyn, Urban Development Staff, Technical Assistance Bureau, Agency for International Development, Washington, D.C.
349. Chief of Engineers, Department of the Army, Attn: ENGME-RD, Washington, D.C. 20314
- 350-359. Wyndham Clarke, Director, Research on Planning for Urban Growth Division, HUD, Washington, D.C. 20410
360. Bruce C. Clarke, Jr., Director, Office of Strategic Research, CIA, Washington, D.C. 20505
361. James E. Cliatt, Office of Economic Opportunity, 730 Peachtree Street NE, Atlanta, Georgia 30308
362. Charles E. Collins, TVA, 604 Power Building, Chattanooga, Tennessee
363. Commander, Field Command, Defense Atomic Support Agency, Sandia Base, Albuquerque, New Mexico 87100
364. James Cowhig, National Science Foundation, Washington, D.C. 20550
365. William T. Cox, Agricultural Engineer, U.S. Department of Agriculture, Federal Extension Service, Washington, D.C. 20250
366. Paul P. Craig, Brookhaven National Laboratory, Associated Universities, Upton, Long Island, New York
367. Earl Crisler, President, LAMBDA Corporation, 1501 Wilson Blvd., Suite 500, Arlington, Virginia 22209
368. William Cross, ASCS State Office, U.S. Courthouse, 8th and Broadway, Nashville, Tennessee
369. Alvin M. Cruze, Research Triangle Institute, Raleigh, North Carolina
370. Louise W. Cureton, 2008 Velmetta Circle, Knoxville, Tennessee 37920
371. Neal E. Cutler, Fulbright Research Fellow, University of Helsinki, Institute of Political Science, Hallituskatu 11-13, 00100 Helsinki 10, Finland
372. John Darrah, AFWL/ESE, Kirtland AFB, New Mexico 87117
373. Henry David, Executive Secretary, Division of Behavioral Sciences, National Academy of Sciences, 2101 Constitution Avenue, Washington, D.C. 20418
374. Julian Davidson, Director, Site Defense, Safeguard Systems Office, 1300 Wilson Blvd., Arlington, Virginia 22209
375. Harold David, Operations Analysis Division, Weapons Evaluation & Control Bureau, Arms Control & Disarmament Agency, State Department Building, Washington, D.C.

376. John E. David, Director, Defense Civil Preparedness Agency, Washington, D.C. 20301
377. L. J. Deal, Division of Operational Safety, USAEC, Washington, D.C. 20545
378. Defense Documentation Center, Cameron Station, Alexandria, Virginia
379. Defense Supply Agency, Defense Logistics Services Center, Battle Creek Federal Center, Attn: Anna K. Winger, Librarian, Battle Creek, Michigan 49016
380. Department of the Air Force, DCS Programs and Resources, Engineering Division, Building 626, Bolling Air Force Base, Washington, D.C. 20332
381. The Dikewood Corporation, 1009 Bradbury Drive, S.E., University Research Park, Albuquerque, Attn: Mary Berran, Librarian, New Mexico 87106
382. Ronald G. Dodson, U.S. Army Corps of Engineers, Omaha, Nebraska
383. Lloyd A. Dove, Public Works Administrator, P.O. Box 2842, City of St. Petersburg, St. Petersburg, Florida 33731
384. James M. Duncan, 400 East Orangethrope Avenue, Anaheim, California 92801
385. R. Easley, Department of Defense Research and Engineering, The Pentagon, Washington, D.C. 20310
386. Bruce Easton, Emergency Preparedness Division, Agricultural Stabilization and Conservation Service, USDA, Room 6628, South Building, Washington, D.C. 20250
387. Hanford Edsall, Office of Civil Defense, Department of the Army, The Pentagon, Washington, D.C. 20310
388. Richard Engels, U.T. Center for Business and Economic Research, University of Tennessee, Knoxville, Tennessee 37916
389. The Engineer School, Library, Fort Belvoir, Virginia
390. Lloyd Eno, Office of Emergency Preparedness, Washington, D.C. 20504
391. John A. Ewing, Director, UT-AEC Agricultural Research Laboratory, 104 Morgan Hall, Knoxville, Tennessee
392. Henry Eyring, University of Utah, Salt Lake City, Utah
393. Mr. Abbott Ferriss, Department of Sociology, Emory University, Atlanta, Georgia
394. Harold B. Finger, Assistant Secretary, Research and Technology, Housing and Urban Development, Washington D.C.
395. D. J. Fink, General Manager, Space Systems, G.E. Space Technology Center, Valley Forge, Pennsylvania
396. Mr. Robert E. Firestine, Research Associate, Urban Studies Bureau, 125, Building E, University of Florida, Gainesville, Florida 32601
397. L. N. FitzSimons, Defense Civil Preparedness Agency, Washington, D.C. 20301
398. Walter J. Flanagan, Department of the Army, Office of the Chief of Engineers, Washington, D.C. 20314
399. Thomas Floyd, Department of Housing and Urban Development, Federal Housing Authority, Washington D.C. 20410
400. Col. W. E. Fluhn, DFCE, U.S. Air Force Academy, Colorado Springs, Colorado
401. J. S. Foster, Jr., Director of Defense Research and Engineering, Department of Defense, Washington, D.C. 20310
402. Raymond R. Fox, Nuclear Defense Design Center, School of Engineering and Applied Sciences, The George Washington University, Washington, D.C.
403. Col. Robert L. Fox, Office of Civil Defense, National Guard Armory, Nashville, Tennessee 37204
404. B. E. Freeman, Systems Science and Software, P.O. Box 1620, La Jolla, California
405. Dr. Moye W. Freymann, Carolina Population Center, University of North Carolina, Chapel Hill, North Carolina 27514
406. P. J. Friel, Block Engineering Company, Cambridge, Massachusetts
407. Allen A. Futral, Chief of Engineers, U.S. Army (ENGTE-EP), The Pentagon, Washington, D.C.
408. Lincoln F. Gallacher, Records Management & Communications, Soil Conservation Service, U.S. Department of Agriculture, Room 0303, South Building, Washington, D.C. 20250
409. Omer R. Galle, Department of Sociology and Anthropology, Vanderbilt University, Nashville, Tennessee 37203
- 410-411. Carl C. Gametsfelder, RPS, Room 008, U.S. Atomic Energy Commission, Washington, D.C. 20545
412. Clark D. Garland, Assistant Professor, Agricultural Economics, Agricultural Extension Service, P.O. Box 71, Knoxville, Tennessee 37901
413. Ralph Garrett, Office of Civil Defense, Department of the Army, The Pentagon, Washington, D.C.
414. James Glass, University of Tennessee, 1008B McClung Tower, Knoxville, Tennessee

415. Harold Goldblatt, Urban Growth Policy Division, Department of Housing and Urban Development, Washington, D.C. 20410
416. William T. Golden, 40 Wall Street, New York 10006
417. Donald Goldman, Defense Research Corporation, Washington, D.C.
418. Harold Goldsmith, Chief Population Research Section, Mental Health Study Center, National Institute of Mental Health, Adelphia, Maryland 20783
419. Robert E. Graham, Head, Office of Business Economics, Department of Commerce, Washington, D.C. 20230
420. Sidney Graybeal, U.S. Arms Control and Disarmament Agency, New State Department Building, Washington, D.C. 20451
421. A. H. M. Greene, Emergency Supply Planning Branch, Department of Supply and Service, 141 Laurier Avenue, West, Ottawa 4, Canada
422. Douglas Griffin, Defense Civil Preparedness Agency, Washington, D.C.
423. S. A. Griffin, Dean of Department of Agriculture, Tennessee Polytechnic Institute, Cookeville, Tennessee 38501
424. D. P. Groeninger, National Military Command System Support Center, The Pentagon, Washington D.C.
425. Abram Grossman, Department of Housing & Urban Development, 451 Seventh St. S.W., Washington, D.C.
426. W. Grubb, General Electric Company, Missile and Space Division, Philadelphia, Pennsylvania
427. W. N. Grune, Department of Civil Engineering, University of Miami, Coral Gables, Florida
428. Charles G. Gunnerson, Manager, Sanitary Engineering Laboratory, Stanford Research Institute, 19722 Jamboree Boulevard, Irvin, California 92664
429. David A. Hake, Director, Center for Business and Economic Research, College of Business Administration, The University of Tennessee, Knoxville, Tennessee 37916
430. N. Hall, UT-AEC Agricultural Research Laboratory, Oak Ridge, Tennessee 37830
431. W. J. Hall, Department of Civil Engineering, University of Illinois, 1108 Civil Engineering Building, Urbana, Illinois 61801
432. W. W. Hammerschmidt, Executive Secretary, Defense Science Board, Department of Defense, Washington, D.C.
433. J. T. Hanley, University of Minnesota, Department of Civil Engineering, Minneapolis Minnesota 55455
434. Norman G. Hansen, Department of the Army, Office of the Chief Engineers, Washington, D.C.
435. Howard P. Harrenstien, Dean, School of Engineering, University of Miami, Miami, Florida 33124
436. Thomas L. Harvey, M.D., V.A. Hospital, Lake City, Florida 32055
437. J. A. Hay, 231 Sir John Carling Building, Ottawa 5, Ontario, Canada
438. W. C. Hebert, System Development Corporation, Santa Monica, California
439. Edward L. Hill, Research Triangle Institute, P.O. Box 12194, Research Triangle Park, North Carolina 27709
440. Jerald E. Hill, 1700 Main Street, Santa Monica, California
441. Jane Hinkel, Department of Housing and Urban Development, Room 4266, Washington, D.C. 20410
442. David Hirschberg, Bureau of Economic Analysis, Department of Commerce, 2500 "M" St., Washington, D.C.
443. C. S. Hobbs, Head, Animal Husbandry, University of Tennessee, 206 Animal Sciences, Knoxville, Tennessee
444. Robert Hobson, Tennessee Department of Agriculture, USDA, 552 U.S. Courthouse, P.O. Box 1250, Nashville, Tennessee
445. Ronald Hofmann, Deputy Department Manager, Applied Mechanics Department, Physics International Company, 2700 Merced Street, San Leandro, California 94577
446. Robert M. Holcomb, Department of Civil Engineering, Texas A&M University, College Station, Texas 77843
447. David C. Holder, P.E., Research Associate, School of Architecture, University of Colorado, Boulder, Colorado 80302
448. Christopher Holmes, Central Intelligence Agency, Washington, D.C. 20505
449. Charles Hoover, Bell Telephone Laboratory, Whippany, New Jersey
450. G. B. Hotchkiss, Office of Emergency Preparedness, Washington, D.C. 20504
451. Jonathan B. Howes, Urban America Inc., 1717 Massachusetts Avenue, N.W., Suite 300, Washington, D.C. 20036
452. Glenn Howze, Department of Sociology, Tuskegee, Alabama 36088

453. Hudson Institute, Library, Croton-on-Hudson, New York
454. Illinois Institute of Technology Research Institute, Library, Chicago, Illinois
455. Lowell B. Jackson, University Extension, University of Wisconsin, Madison, Wisconsin
456. William Jackson, Office of Economic Opportunity, 1200 19th Street, Washington, D.C. 20410
457. H. F. Jarrett, California State College of Long Beach, Long Beach, California 90804
458. Hans E. Jensen, Head, Department of Economics, University of Tennessee, Knoxville, Tennessee 37916
459. Q. L. Jepson, Kentucky State University, Manhattan, Kentucky
460. Harry L. Johnson, University of Tennessee, Department of Finance, Knoxville, Tennessee
461. Robert L. Johnson, Assistant Secretary of the Army for Research and Development, Department of Defense, Washington, D.C.
462. Chief, Joint Civil Defense Support Group, Office, Chief of Engineers, Department of the Army, Attn: ENGMCD, Washington, D.C. 20314
463. Lewis W. Jones, Department of Sociology, Drawer VV, Tuskegee Institute, Tuskegee, Alabama 36088
464. Herman Kahn, Hudson Institute, Croton-on-Hudson, New York 10520
465. G. A. Karas, Department of Housing and Urban Development, Federal Housing Authority, Washington, D.C. 20410
466. Jack R. Kelso, Defense Atomic Support Agency, Department of Defense, Washington, D.C. 20305
467. Kenneth B. Kenny, Graduate School of Planning, University of Tennessee, Knoxville, Tenn. 37916
468. Robert P. Kennedy, Holmes and Narver, Inc., 400 East Orangethrope Ave., Anaheim, Calif. 92801
469. Vincent H. Kerberg, Director, Emergency & Communication Services, 300 North "D" Street, San Bernardino, California 92418
470. H. L. Kilburn, U.S. Atomic Energy Commission, P.O. Box "A", Aiken, South Carolina 29801
471. H. A. Knapp, Institute for Defense Analysis, 400 Army-Navy Drive, Arlington, Va. 22202
472. Carl Koontz, Department of Civil Engineering, Worcester Polytechnic Institute, Worcester, Mass. 01609
473. Robert A. Krupka, Hudson Institute, Croton-on-Hudson, New York
474. Richard Kummer, 101 Engra, Pennsylvania State University, University Park, Pennsylvania
475. Laboratory and University Division, AEC-ORO
476. Walter H. Lamb, Rural Civil Defense Leader, 820 East Speedway, Tuscon, Arizona 85719
477. H. A. Lamonds, EG&G, Inc., P.O. Box 98, Goleta, Calif. 93717
478. Albert Latter, R & D Associates, P.O. Box 3580, Santa Monica, Calif. 90405
479. Richard K. Laurino, System Sciences, Inc., 750 Welch Road, Palo Alto, California 94304
480. Ann S. Lee, Institute for Behavioral Research, 624 Graduate Studies Center, University of Georgia, Athens, Georgia 30601
481. Everett S. Lee, Social Science Research Institute, University of Georgia, Athens, Georgia 30601
482. Howard F. Lehnert, Jr., Program Leader, Emergency Preparedness, USDA Extension Service, Washington, D.C. 20250
483. J. A. Lieberman, Environmental Protection Agency, 5600 Fishers Lane, Rockville, Md. 20852
484. George A. Lincoln, Director, Office of Emergency Preparedness, Executive Office of the President, Washington, D.C. 20540
485. Ralph H. Long, Jr., Division of Advanced Technology Applications, National Science Foundation, 1800 G Street, Washington, D.C. 20550
486. A. Longinow, IIT Research Institute, 10 West 35th Street, Chicago, Illinois 60616
487. James H. Lord, University of Tennessee, Knoxville, Tenn. 37916
488. Fletcher Luck, University of Tennessee, Agricultural Extension Service, P.O. Box 1071, Knoxville, Tenn.
489. Stephen J. Lukasik, Director, Defense Advanced Research Projects Agency, 1400 Wilson Blvd., Arlington, Va. 22209
490. Hugh H. Macaulay, Economics Dept., Clemson University, Clemson, S.C. 29631
491. S. E. MacGregor, Agriculture Research Branch, Plant Industry Station, Beltsville, Maryland 20705
492. Daniel R. Mandelker, Visiting Professor, Columbus University, 435 West 116th Street, New York, New York 10027
493. C. T. Marsh, Savannah River Operations Office, U.S. Atomic Energy Commission, P.O. Box "A", Aiken, South Carolina 29801

494. Thomas Martin, University of Florida, Gainesville, Florida
495. Wayne Martin, McDonnell-Douglas, 5301 Bolsa, Mail Station 10, Huntington Beach, California 92647
496. Walter E. Matson, Agricultural Engineer, Oregon State University, Corvallis, Oregon
497. J. R. Maxfield, Jr., Radiology and Nuclear Medicine, Maxfield Clinic Hospital, 2711 Oak Lawn Avenue, Dallas, Texas 75219
498. J. R. Maxfield, P.O. Box 9503, Lakewood Station, Dallas, Texas 75214
499. William Marty, Unified San Diego County Civil Defense and Disaster Organization, 7939 John Towers Avenue, Santee, California 92071
500. Glenn C. McCann, Department of Sociology and Anthropology, Box 5428, North Carolina State University, Raleigh, North Carolina 27607
501. J. A. McCullough, Department of Housing and Urban Development, Federal Housing Authority, Washington, D.C.
502. Peter C. McGillivray, Director, Civil Defense, Palmer Park, Detroit, Michigan
503. C. E. McLain, DARPA, The Pentagon, Washington, D.C.
504. William G. McMillan, Department of Chemistry, University of California, Los Angeles, California 90024
505. John C. Meadows, Forestry Department, Iowa State University, Ames, Iowa 50010
506. C. R. Mehl, Sandia Corporation, P.O. Box 5800, Albuquerque, New Mexico 87115
507. J. R. Menke, 44 Ogden Road, Scarsdale, New York
508. R. G. Menotti, U.S. Army ABMDA, P.O. Box 1500, Huntsville, Alabama
509. Norvan Meyer, Veterinarian, Emergency Animal Disease, Animal Health Division, U.S.D.A., Federal Center Building, Hyattsville, Maryland 20782
510. Ann R. Miller, Population Studies Center, 3718 Locust Street, University of Pennsylvania, Philadelphia 19104
511. George E. Miller, Agricultural Engineer, Extension Service, University of California, Davis, California
512. William M. Miller, 307 More Hall, University of Washington, Seattle, Washington 98105
513. Adolph T. Molin, Advanced Power Engineering Department, United Engineers and Constructors, Inc., 1401 Arch Street, Philadelphia, Pennsylvania 19105
514. John R. Morre, Department of Economics, University of Tennessee, Knoxville, Tennessee
515. Richard N. Moore, Civil Defense Director, P.O. Box 385, Blountsville, Tennessee 37617
516. Robert D. Morgan, OCD, Region 3, P.O. Box 108, Thomasville, Georgia
517. Peter Morrison, The RAND Corporation, 1700 Main Street, Santa Monica, California 90406
518. Peter Moulthrop, Lawrence Radiation Laboratory, P.O. Box 808, Livermore, California
519. Walter Murphey, "SURVIVE," P.O. Box 910, Starke, Florida 32091
520. Selma Mushkin, Georgetown University, Washington, D.C.
521. George C. Myers, Sociology Department, Duke University, Durham, North Carolina 27706
522. David L. Narver, Jr., Holmes and Narver, 400 East Orangethrope Ave., Anaheim, Calif. 92801
523. E. F. Newmar, U.S. Atomic Energy Commission, Oak Ridge, Tennessee 37830
524. I. M. Newman, World Health Organization, World Health House, Ring Road, New Delhi, India
525. Peter G. Nordlie, Research Director Human Sciences Research, Inc., Westgate Research Park, 7710 Old Springhouse Road, McLean, Va. 22101
526. John A. Northrop, Deputy Director, Science & Technology, Defense Atomic Support Agency, DOD, Washington, D.C. 20305
527. Office of the Secretary of Defense, Installations and Logistics, Room 3C771, The Pentagon, Washington, D.C. 20301
528. A. G. Olson, Rural Route 3, Willmar, Minnesota 56201
529. Operations Research and Economics DW Library, Attn: Mrs. Patricia D. Chapman, Research Triangle Institute, P.O. Box 12194, Research Triangle Park, N.C. 27709
530. Richard Park, National Academy of Sciences, Washington, D.C. 20418
531. PARM Project, 7th Floor, 1424 16th Street, N.W. Washington, D.C.
532. Edgar Parsons, Research Triangle Institute, Raleigh, N.C.
533. Sidney Passman, U.S. Arms Control and Disarmament Agency, New State Department Building, Washington, D.C. 20451

534. Charles E. Patterson, Jr., Bureau of Public Administration, Department of Political Science, 1007 McClung Tower, University of Tennessee, Knoxville, Tenn. 37916
535. David A. Patterson, Budget and Planning Staff, TVA, 410 New Sprankle Bldg., Knoxville, Tenn. 37902
536. A. L. A. Patti, Room 321, Office of Emergency Preparedness, EOBA, Washington, D.C.
537. Arthur W. Peabody, Clay School, Room 101, 2012 Fourth Street S., Minneapolis, Minnesota
538. J. C. Petee, National Resource Analysis Center, Office of Emergency Planning, Washington, D.C.
539. Jack Peterson, Defense Coordinator, General Services Administration, DROE, Room 3018, Washington, D.C. 20405
540. Charles Phillips, U.S. Army Biological Laboratory, Fort Detrick, Md.
541. S. L. Pittman, Shaw, Pittman, Potts and Trowbridge, 910 17th Street, N.W., Washington, D.C. 20006
542. Harris M. Pope, Deputy Regional Director, Region 3 Civil Defense, Thomasville, Georgia 31792
543. Patricia Postma, 104 Berea Road, Oak Ridge, Tenn. 37830
544. Serge B. Pretre, Head, Section for Protection of Persons and Environment, Safety Inspectorate of Nuclear Installations, CH-5303 Wurenlingen, Switzerland
545. F. B. Porzel, Institute for Defense Analysis, 400 Army-Navy Drive, Arlington, Va. 22202
546. Abner Sachs, Institute for Defense Analyses, 400 Army-Navy Drive, Arlington, Virginia 22202
547. J. A. Samuel, Department of Mechanical Engineering, University of Florida, Gainesville, Florida 32601
548. W. Sassin, Kernforschungsanlage Julich, KFA, 517 Julich 1, Postfach 365
549. Edward Saunders, Office of Emergency Preparedness, Washington, D.C. 20504
550. Herbert A. Sawyer, Civil Engineering Department, University of Florida, Gainesville, Florida
551. Larry Schindler, Office of the Chief of Engineer, Department of the Army, Attn: ENGMC-ED, Forrestal Bldg., Room 2E044, Washington, D.C. 20314
- 552-561. W. W. Schroebel, Analysis and Evaluation Branch, Division of Biomedical and Environmental Research, U.S. Atomic Energy Commission, Washington, D.C. 20545
562. F. Seitz, President, Rockefeller University, New York, N.Y.
563. Frank Sevcik, General Research Corporation, 1501 Wilson Blvd., Suite 700, Arlington, Va. 22209
564. E. C. Shannan, Agricultural Research Service, U.S. Department of Agriculture, Washington, D.C.
565. Demitri B. Shimkin, 106 W. Pennsylvania Avenue, Urbana, Illinois 61801
566. A. F. Shinn, Department of Biological Sciences, Paterson State College, 300 Pomton Road, Wayne, N.J. 07470
567. W. L. Shouse, Graduate School of Planning, University of Tennessee, Knoxville, Tennessee 37916
- 568-577. Alan R. Siegel, Director, Division of Environmental Factors and Public Utilities, Department of Housing and Urban Development, Washington, D.C. 20410
578. A. R. Simpson, Department of the Army, Office of the Chief of Engineers, Washington, D.C.
579. James R. Simpson, Department of Housing and Urban Development, Washington, D.C.
580. W. J. Simpson, AEC-Savannah River Operations Office, P.O. Box "A", Aiken, South Carolina
581. George N. Sisson, Shelter Research Division, Defense Civil Preparedness Agency, Washington, D.C. 20301
582. H. A. Slayden, MSFC/NASA, Huntsville, Alabama
583. R. S. Sleeper, University of Tennessee Space Institute, Tullahoma, Tennessee 37388
584. John B. Smith, Tennessee Valley Authority, 720 Chattanooga Bank Bldg., Chattanooga, Tennessee 37240
585. Wesley Smith, Tennessee Valley Authority, Muscle Shoals, Alabama
586. Elvira Smyrl, Montana State University, School of Architecture, Bozeman, Montana
587. Richard C. Snyder, Mershon Center, Ohio State University, 199 West 10th Ave., Columbus, Ohio 43201
588. Lewis V. Spencer, National Bureau of Standards, Washington, D.C.
589. Joseph J. Spengler, Economics Dept., Duke University, Durham, N.C. 27706
590. Robert B. Sprankle, Architectural Engineering, Pennsylvania State University, University Park, Pennsylvania
591. Stanford Research Institute, Library, Menlo Park, California
592. Sylvan P. Stern, 300 Jay Street, Brooklyn, New York 11202
593. C. Shannan Stokes, Sociology Department, University of Georgia, Athens, Georgia 30601
594. Perry R. Stout, Kearney Foundation of Soil Science, 265 Hoagland Hall, University of California, Davis, Calif. 95616

595. E. A. Straker, Suite 700, 2109 Clinton Avenue, Science Applications, Inc., Huntsville, Alabama 35805
596. John Strange, Nuclear Weapons Effects Division, U.S. Army Engineer Waterways Experiment Station, P.O. Box 631, Vicksburg, Mississippi 39180
597. W. E. Strobe, Defense Civil Preparedness Agency, Washington, D.C. 20301
598. Alfred Stuart, Chairman, Geography Dept., University of North Carolina at Charlotte, Charlotte, N.C.
599. R. B. Sturgis, Department of Sociology, Western Illinois University, Macomb, Illinois 31455
600. Raymond H. Swan, Division of Operational Safety, U.S. Atomic Energy Commission, Washington, D.C. 20545
601. J. A. Swartout, Union Carbide Corporation, New York, New York
602. Frank P. Szabo, Defense Research Establishment, Ottawa, Ontario, CANADA, KIA OZ4
603. C. M. Taeuber, Oak Ridge Associated Universities, SRDG, Oak Ridge, Tennessee 37830
604. Karl E. Taeuber, Chairman, Department of Sociology, The University of Wisconsin, Madison, Wisconsin 53706
605. James Tarver, Department of Sociology, University of Georgia, Athens, Georgia 30601
606. Lauriston Taylor, National Academy of Sciences, Washington, D.C. 20418
607. Edward Teller, Lawrence Livermore Laboratory, P.O. Box 808, Livermore, Calif. 94550
608. Michael P. Tierney, U.S. Bureau of Mines, Division of Mining Research & Reserves, Washington, D.C. 20249
609. Darrell M. Trent, Deputy Director, Office of Emergency Preparedness, Washington, D.C. 20504
610. William Truppner, Director, National Resource Analyses Center, Office of Emergency Preparedness, Washington, D.C. 20504
611. Leonard Rabins, General Electric Company, 100 Woodlawn Avenue, Pittsfield, Mass. 01201
612. Andre M. Ranford, Mitre Corporation, Bedford, Mass.
613. Daughtridge S. Reynolds, Department of the Army, Washington, D.C.
614. Bernice Rideout, Office of Civil Defense, Statehouse, Augusta, Maine 04330
615. Roger Riefler, Department of Economics, University of Pittsburg, Pittsburg, Pa. 15213
616. Herbert Roback, Staff Administrator, Subcommittee for Military Operations, U.S. House of Representatives, Washington, D.C.
617. James E. Roberts, Chairman, Department of Civil Engineering and Applied Mechanics, San Jose State College, San Jose, California
618. Vincent P. Rock, National Research Council, National Academy of Sciences, 2101 Constitution Avenue, Washington, D.C. 20418
619. Robert Rodden, Operations Evaluation Dept., Stanford Research Institute, Menlo Park, Calif. 94025
620. Harry E. Roderick, Defense Civil Preparedness Agency, 1E545, The Pentagon, Washington, D.C. 20301
621. James E. Roembke, Architectural and Engineering Services Division, Defense Civil Preparedness Agency, Washington, D.C. 20301
622. Joseph Romm, Systems Sciences, Inc., 4720 Montgomery Lane, Bethesda, Maryland 20014
623. Dorothy Rosenberg, Department of Sociology, University of Pittsburgh, Pittsburgh, Pennsylvania
624. Al Rosenthal, RAND Corporation, 1700 Main Street, Santa Monica, Calif. 90405
625. John H. Rust, University of Chicago, Section of Nuclear Medicine, Chicago, Illinois
626. Mason P. Rumney, IITRI, 1825 K. Street, Washington, D.C.
627. Lawrence Russell III, The Chief of Engineers, Department of the Army, Director T and ME, Washington, D.C. 20315
628. Richard A. Uher, Westinghouse Electric Corporation, Vehicle Systems Group, Transportation Division, Avenue A and West Street, East Pittsburgh, Pennsylvania 15112
629. U.S. Army Engineer Research and Development Laboratories, Library, Fort Belvoir, Virginia
630. U.S. Naval Civil Engineering Laboratory, Library, Port Hueneme, California 93041
631. Edward Vance, Stanford Research Institute, Bldg. 406A, 333 Ravenswood Ave., Menlo Park, California 94025
632. E. S. Vasquez, Acting Chief, Joint Civil Defense Support Group, Directorate of Military Construction, Department of Army, Office of the Chief of Engineers, Washington, D.C. 20314
633. D. R. Vaughn, Department of Transportation, Office of Emergency Transportation, Washington, D.C.
634. G. K. Vetter, School of Architecture, University of Colorado, Boulder, Colorado 80302
635. W. H. von Aulock, Bell Telephone Laboratory, Whippany, New Jersey 07981
636. L. Vortman, Sandia Corporation, Albuquerque, New Mexico

637. Edward Walls, University of Tennessee, Department of Finance, Knoxville, Tenn. 37916
  638. Carl Walske, Chairman of Military Liaison Committee, U.S. Atomic Energy Commission, Washington, D.C. 20545
  639. George Walter, Office of Intergovernmental Affairs, U.S. Department of Agriculture, Washington, D.C. 20250
  640. Keith Ward, University of Tennessee, Knoxville, Tenn. 37916
  641. A. E. Warner, Dean, College of Business, University of Tennessee, Knoxville, Tenn. 37916
  642. Shields Warren, Director of Laboratories, New England Deaconess Hospital, Boston, Massachusetts
  643. Benjamin W. Watson, Executive Secretary, U.S. Civil Defense Council, Editorial Office, P.O. Box 370, Portsmouth, Virginia 23705
  644. Leon Weaver, School of Police Administration, Michigan State University, East Lansing, Michigan 48823
  645. Phillip H. Weaver, Eastern Area Director, Intergovernmental Affairs, Department of Agriculture, Office of the Secretary, Washington, D.C. 20250
  646. Werner Weber, Director, New York State Civil Defense Commission, Public Security Building, State Office Building Campus, Albany, New York 12226
  647. Lee Webster, Advanced Ballistic Missile Defense Agency, Huntsville Office, ABH-S, P.O. Box 1500, Huntsville, Alabama 35807
  648. F. J. Wells, The Mitre Corporation, Box 208, Bedford, Massachusetts
  649. Thomas J. Whatley, Head, Department of Agricultural Economics, University of Tennessee, Knoxville, Tennessee 37916
  650. Clayton S. White, Lovelace Foundation, Albuquerque, New Mexico 87108
  651. William White, Stanford Research Institute, Menlo Park, California
  652. Carl K. Wiehle, Civil Defense Technical Office, Stanford Research Institute, Menlo Park, Calif. 94025
  653. Elbert W. Wilson, 1416 Currier Lane, Knoxville, Tennessee 37919
  654. Walter Wood, Dikewood Corporation, Albuquerque, New Mexico
  655. George W. Wright, Office of Deputy Undersecretary, Department of Housing & Urban Development, Washington, D.C.
  656. Michael Ziegler, Department of Psychology, York University, 4700 Keele St., Toronto, Ontario, Canada
  657. Martin Zlotnick, Advanced Ballistic Missile Defense Agency, 1300 Wilson Boulevard, Arlington, Virginia 22209
  658. Patent Office, AEC, ORO
- 659-912. Given Distribution as shown in TID-4500 under Health and Safety category (25 copies - NTIS)