

REPORT DOCUMENTATION PAGE

Form Approved
OMB No. 074-0188

Public reporting burden for this collection of information is estimated to average 1 hour per response, including the time for reviewing instructions, searching existing data sources, gathering and maintaining the data needed, and completing and reviewing this collection of information. Send comments regarding this burden estimate or any other aspect of this collection of information, including suggestions for reducing this burden to Washington Headquarters Services, Directorate for Information Operations and Reports, 1215 Jefferson Davis Highway, Suite 1204, Arlington, VA 22202-4302, and to the Office of Management and Budget, Paperwork Reduction Project (0704-0188), Washington, DC 20503

1. AGENCY USE ONLY (Leave blank)		2. REPORT DATE 2000	3. REPORT TYPE AND DATES COVERED Proceedings, May 8-12, 2000	
4. TITLE AND SUBTITLE Actively Controlled Vortex Disposal System for Sludge Wastes			5. FUNDING NUMBERS N/A	
6. AUTHOR(S) Neil C. Widmer, Jerald A. Cole, Wm. Randall Seeker, Kenneth J. Wilson, Timothy P. Parr, and Klaus C. Schadow				
7. PERFORMING ORGANIZATION NAME(S) AND ADDRESS(ES) General Electric-Energy and Environmental Research Division, 18 Mason St. Irvine, CA			8. PERFORMING ORGANIZATION REPORT NUMBER N/A	
9. SPONSORING / MONITORING AGENCY NAME(S) AND ADDRESS(ES) SERDP 901 North Stuart St. Suite 303 Arlington, VA 22203			10. SPONSORING / MONITORING AGENCY REPORT NUMBER N/A	
11. SUPPLEMENTARY NOTES No copyright is asserted in the United States under Title 17, U.S. code. The U.S. Government has a royalty-free license to exercise all rights under the copyright claimed herein for Government purposes. All other rights are reserved by the copyright owner.				
12a. DISTRIBUTION / AVAILABILITY STATEMENT Approved for public release: distribution is unlimited.			12b. DISTRIBUTION CODE A	
13. ABSTRACT (Maximum 200 Words) The development of an advanced sludge treatment concept is underway for applications to sludge wastes. The concept integrates primary treatment of sludge in an advanced vortex containment combustor (VCC) with subsequent post treatment in an actively controlled acoustic afterburner. Past efforts have advanced the application of the acoustic afterburner while current activities are focused on development of the VCC. The VCC resembles a cyclone particle separator that is specifically engineered to generate a suspended, spinning combustion zone. In the VCC, combustion air is introduced through a number of tangentially directed slots into a conical shaped combustor. The design establishes an aerodynamic separator that effectively traps particles and fly ash in the chamber via centrifugal forces. The tangential co-injection of fuel and sludge into the large radius, narrow width region of the combustor generates a suspended cloud of fuel and sludge particles. The particles remain in a tight spinning reaction zone just above the air injection vanes where they burn in a suspended phase away from the walls. Fine ash particles are then selectively separated from the combustion region and move to the ash removal cone. The ash eventually migrates to the bottom of the chamber where it is removed.				
14. SUBJECT TERMS SERDP, SERDP Collection, sludge combustor, , VCC, sludge waste			15. NUMBER OF PAGES 15	
			16. PRICE CODE N/A	
17. SECURITY CLASSIFICATION OF REPORT unclass	18. SECURITY CLASSIFICATION OF THIS PAGE unclass	19. SECURITY CLASSIFICATION OF ABSTRACT unclass	20. LIMITATION OF ABSTRACT UL	

NSN 7540-01-280-5500

Standard Form 298 (Rev. 2-89)
Prescribed by ANSI Std. Z39-18
298-102

20000921 031

DTIC QUALITY INSPECTED 4

19th International Conference on Incineration and Thermal Treatment Technologies, Portland, OR, May 2000

ACTIVELY CONTROLLED VORTEX DISPOSAL SYSTEM FOR SLUDGE WASTES

Neil C. Widmer, Jerald A. Cole and Wm. Randall Seeker
GE Energy and Environmental Research Corporation
Irvine, CA

Kenneth J. Wilson, Timothy P. Parr and Klaus C. Schadow
U.S. Naval Air Warfare Center, Weapons Division
China Lake, CA

ABSTRACT

The development of an advanced sludge treatment concept is underway for applications to sludge wastes. The concept integrates primary treatment of sludge in an advanced vortex containment combustor (VCC) with subsequent post treatment in an actively controlled acoustic afterburner. Past efforts have advanced the application of the acoustic afterburner while current activities are focused on development of the VCC. The VCC resembles a cyclone particle separator that is specifically engineered to generate a suspended, spinning combustion zone. In the VCC, combustion air is introduced through a number of tangentially directed slots into a conical shaped combustor. The design establishes an aerodynamic separator that effectively traps particles and fly ash in the chamber via centrifugal forces. The tangential co-injection of fuel and sludge into the large radius, narrow width region of the combustor generates a suspended cloud of fuel and sludge particles. The particles remain in a tight spinning reaction zone just above the air injection vanes where they burn in a suspended phase away from the walls. Fine ash particles are then selectively separated from the combustion region and move to the ash removal cone. The ash eventually migrates to the bottom of the chamber where it is removed.

Design features of the VCC combine compactness with long particle retention times that allows for complete burnout, very low particle emissions and good turndown ratio. The VCC has demonstrated over 99.9% combustion efficiency and better than 90% ash retention with pulverized bituminous coal.

The development work currently underway is intended to transition the VCC from coal combustion application to the thermal treatment of sludge wastes. Under this program, a team comprising GE Energy and Environmental Research Corporation and the U.S. Naval Air Warfare Center, Weapons Division are developing specifications for various critical elements of the VCC. The team is developing these specifications by integrating small-scale tests, isothermal modeling, engineering assessments and full-scale combustion tests. The critical elements to be demonstrated include transition from coal and gaseous fuels to diesel oil, integrating mechanical sludge injection, establishing a suspended combustion region, demonstrating effective particle burn out and ash trapping and optimizing combustion stability. The results of these efforts are presented. Ultimately two modes of operation will be evaluated. Initially a conventional fuel-lean combustion mode will be assessed. Finally the transition to a fuel-rich pyrolysis mode will be investigated to allow integration with a compact actively controlled afterburner. This effort is part of a multi-year program sponsored by U.S. Navy Strategic Environmental Research and Development Program.

INTRODUCTION

Advanced combustion techniques for shipboard waste processing are being developed by the U.S. Navy to replace existing treatment systems. These advanced systems must handle an increasing variety and throughput of wastes and be of essentially the same size as existing onboard units. Currently only blackwater waste is treated onboard, however, in order for the Navy to comply with International Maritime Organization standards, future waste streams will include gray water and oily bilge water sludges. Sludge processing rates are expected to double although the sludge streams will still comprise mostly water. After pretreatment, the solid content is expected to double to 4 percent while the oil content may reach maximum levels of 20 percent.

In addition to shipboard applications, this technology has applications to a wide variety of oily sludge wastes generated in the military by activities such as vehicle and aircraft wash down. These oily wastes can contain significant levels of water and particulate matter including toxic metals and must be treated in an environmentally acceptable manner. Energy and Environmental Research Corporation (EER), a wholly owned subsidiary of General Electric Company, is working with the Naval Air Warfare Center, Weapons Division in the development of a compact thermal treatment system for these sludge wastes. Past efforts (1,2,3) have focused on the development of an acoustic afterburner component of the active combustion control system. This afterburner technology demonstrated robust operation and low emissions in a compact device. The current effort, which is the subject of this paper, involves development of a compact primary thermal treatment technology. The approach involves converting a high firing density coal combustor to fuel oil operation and integrating liquid sludge injection for thermal treatment. To date the project has been successful in converting the combustor to fuel oil operation and is developing design and operating specifications for demonstrating thermal treatment of sludge wastes.

BACKGROUND

In the early 1980's, EER began development of a coal combustor technology retrofit for oil-fired boilers. The purpose was to enable coal combustion in boilers that were not designed to handle high ash loading. The approach required effective ash retention in the combustor that was achieved by cyclone separation. The combustor, called the Vortex Containment Combustor (VCC), traps and suspends solids in a fire ring and produces a largely ash-free combustion gas (4).

The VCC concept, illustrated in Figure 1, involves a ring-shaped combustion chamber coupled to a classic cyclone-type device. Air is introduced into the combustion chamber through a number of tangentially directed slots. The large diameter, narrow raceway combustion chamber establishes a high performance aerodynamic separator that effectively traps droplets and fly ash in the combustor via centrifugal forces. Co-injection of fuel into the "raceway" generates a suspended reaction zone. Sludge and fuel particles retained in the reaction zone evaporate and burn leaving fine ash particles. As the particle size decreases, aerodynamic drag forces overcome centrifugal forces and carry the particles down into the cyclone section of the combustor. The high rotational velocity in the cyclone section increases the centrifugal separation forces driving fine ash particles to the walls. Along the walls, the particulate enters the aerodynamic boundary layer where they are retained and collected for later removal from the system. Particles that escape the boundary layer are convected downward with the swirling gases. Eventually the swirling gases reverse direction and exit upward along the combustor's axis. At the point of reversal, an aerodynamic stagnation zone occurs and nearly all of the remaining particles fall away from the moving gases by gravitational force.

(Insert Fig. 1 here)

Nearly all the waste thermal treatment systems for processing solids or sludges operate with two process stages: the first being nominally fuel-rich and the second fuel-lean. The reason for this is

simple. Fuel-rich waste thermal treatment requires less air, and hence is more quiescent. This enables most of the solid residue to be retained in the primary chamber for eventual recovery, treatment, and disposal, while only the gaseous effluent is further oxidized in the secondary chamber. The VCC concept is uniquely different in this regard. By design it has a very turbulent primary chamber, but achieves particulate retention through aerodynamic means. The ability of the VCC to retain particulate has been demonstrated in coal combustion systems by a number of investigators, including research teams from EER, as well as TRW and Babcock and Wilcox. Design features of the VCC include compactness, high temperature, long solids retention times, very low particulate emissions and good turndown capability.

To adapt the VCC to sludge treatment involves operating on liquid fuels and integrating liquid waste injection and suspension techniques. Currently specifications have been developed for stable combustion with fuel oils and specifications are being assessed for injection and suspension of sludge wastes.

FACILITIES

The development of the VCC for sludge waste applications was conducted on three test facilities; a sub-scale combustor, a full-scale isothermal model and a full-scale 500 kW combustor. This paper focuses on the full-scale development efforts. Sub-scale efforts are presented separately (5).

Concurrent efforts were conducted on two full-scale facilities. A full-scale isothermal model was used to guide specification of the sludge injection systems. This unit was used to evaluate various injector characteristics including spray angle, injection angle, spray momentum, and droplet size. The isothermal model comprises a plexi-glass replica of the internal dimensions of the full-scale combustor that is shown in Figure 2. The full-scale combustor incorporates castable refractory insulation and a number of ports to allow for flame safety systems, diagnostic probes and various fuel and sludge injection locations and angles.

(Insert Fig. 2 here)

The combustor was operated with approximately 14 cubic meters per minute of air supplied by four radial ports on the outer plenum. The air was then directed into the suspension zone through 12 circumferential air vanes, orientated 45° from radial. The fuel, comprising either natural gas or fuel oil, was injected from discrete radial locations into the combustion raceway. The injection of fuel was angled more radial than the air to ensure the fuel was not driven to the walls. The fuel and air mix and react in the raceway prior to the gas products spiraling into the lower cone region. The gas products then reverse direction and exit upward through the combustor exhaust. The swirl strength in the upward flow is largely governed by the exhaust diameter. Except for boundary-layer friction losses, the rotational energy of the flow in the large diameter raceway is conserved by the flow through the small diameter exhaust. Therefore the angular velocity of the upward exhaust flow is very high and entrained particles are rejected to the walls. The separated ash and particles are then collected in the lower cone region and removed from the combustor.

The full-scale combustor was equipped with fuel, sludge and air feed control and monitoring systems. The operating differential pressure of the VCC was measured between the air inlet and the exhaust duct. Additionally the air vane pressure drop was measured between the air inlet and the VCC chamber. A K-type thermocouple was recessed 10 mm from the surface of the upper refractory wall to provide relative chamber temperatures. An extractive gas-sampling probe was located in the exhaust. The gas sample was delivered to a water knockout and then a continuous emission monitoring system for measurement of oxygen (O₂), carbon dioxide, carbon monoxide (CO) and nitric oxide (NO) concentrations.

The two full-scale VCC test facilities were used to develop specifications for flame stabilization, sludge injection and particle trapping. The efforts conducted to date have focused on switching to fuel oil firing and demonstrating stable combustion with target levels of water injection. Water was selected as an extreme low-heat value surrogate sludge. Also injection specifications for suspending the sludge droplets and trapping particles have been developed.

STATUS AND RESULTS

The target capacity for sludge injection is 3.2 liter per minute (lpm) comprising as much as 98 percent water. The range of sludge compositions that will finally be demonstrated includes up to 4 percent solids and 20 percent oil. Initial development has focused on demonstrating operation with water to evaluate impact on combustion stability.

As a course of action, first the VCC combustor was operated on natural gas to confirm target aerodynamic and thermodynamic performance. The target operating conditions produced approximately 3 kPa pressure drop on isothermal model, however, the increased boundary layer friction from rough walls on the full-scale combustor reduced the pressure drop to 1.7 kPa under ambient operation. When operated at high temperature, the increased volumetric flow rate effectively doubled this pressure drop. The increased pressure drop results from increased kinetic energy rather than rotational energy and the net effect of hot operation is, as expected, a decrease in vortical strength (4). Despite the decreased vortical strength of high temperature operation, the particle trapping performance of the system remains high even for moderately low-pressure drops.

Various natural gas injector configurations were investigated generally relying on a dual point introduction of fuel injecting 30° from radial. Operation with natural gas produced stable combustion and good burnout. CO emissions were below 35 ppm (corrected to 7% O₂). Firing of fuel oil was accomplished with both pressure nozzle and air atomized nozzle injectors. Fuel oil was injected into the suspension region at 25° to 30° from radial. The combustion of fuel oil was likewise stable with low CO emissions. The only noticeable difference in the two flames was the strong radiance of the fuel oil flame that more clearly showed the suspended combustion behavior. Under both natural gas and fuel oil operation the interior surface temperatures were approximately 600°C and pressure drop was 3.5 kPa (14 inches of water column).

In the absence of sludge injection, achieving stable combustion was never much in doubt. However, justifying our concerns on integrating sludge injection, combustion was seen to destabilize with water injection and flame out occurred at flow rates of 1.3 to 1.6 lpm. The suspended combustion approach essentially relies on hot gas entrainment for stability. So as water is injected into this region, the hot gases are quenched until they no longer can support ignition. The result is a rising instability culminating in flame out at some threshold water injection level.

To achieve the target injection rates and optimize flame stability, several injection configurations, shown in Figure 3, were investigated. Figure 3 presents the fuel and sludge injection locations around the VCC raceway and illustrates the flameout threshold water input levels. Essentially for the first round of fuel injector configurations, #1 through #4, the best success was achieved with configuration #1, a single point injection of high velocity natural gas and configuration #4, a dual-point pressure nozzle injection of fuel oil. In these cases, the natural gas jet velocity exceeded 100 m/s while the pressure nozzle injection is similarly energetic. The result is that fuel entrains surrounding gases more rapidly and reduces the quenching effect thus extending the stability limit of the flame. However, the ultimate outcome was only a moderate increase in the water injection capacity up to 1.9 lpm.

(Insert Fig. 3 here)

To overcome the effect of water injection, better stabilization of the flame is required. A new configuration of fuel injectors was tested (#5 and #6) employing an attached-flame pilot at the exit of the fuel injector. The pilot burns approximately 5 percent of the fuel and provides a stabilized ignition source for the main fuel. Under this configuration, the system exceeded the target sludge injection rates without evidence of combustion instabilities. Once a flame stabilizer was incorporated, combustion was very stable over the entire flow range of water injection. The CO emissions at various water injection rates for fuel oil operation are presented in Figure 4. CO emissions were below 30 ppm at target injection levels. The quenching effect of water also reduced thermal NO_x formation and this is illustrated in the NO emission presented in Figure 4. Furthermore the flame was seen to be stable, as characterized by CO emissions, over a wide operating equivalence ratio (Fig. 5) and firing range (Fig. 6).
(Insert Fig. 4, 5, 6 here)

The sludge injector specifications were guided by isothermal modeling studies. From these efforts the parameters recognized to be most important included spray angle, injection angle, jet momentum and atomization quality, i.e. droplet size. Other parameters that effect the injection specification included droplet evaporation rate, gas and particle residence time, particle oxidation rates and other practical consideration for injection of sludge wastes. All these parameters were evaluated to develop the injection specification listed in Table I.

TABLE I
Sludge Injector Specifications

Spray Angle	Narrow (5 to 20°)
Injection Angle	Radially (0 to 30°)
Maximum Droplet Size	300µm
Atomization Air/Water Mass Ratio	15%
Atomization Air Pressure	30 psig
Orifice Size	< 5 mm
Number of Injectors	minimum 2

Based on the isothermal model evaluation of particle retention time, the current system is capable of providing up to 2 seconds of suspended phase residence time for aerodynamically entrained particles. Large particles on the other hand are retained indefinitely in the combustor. The smallest particles remain in the active zone a minimum of 150 ms and only particulate below 3µm escape the VCC. Based on droplet evaporation modeling, small droplets injected into the suspension zone will evaporate very rapidly in less than 50 ms and allow adequate time (100ms) for burnout of remaining organic matter. The large droplets, of roughly 100µm size will evaporate in 200 ms but these droplets are suspended for up to 2 seconds which allows adequate time at temperature for oxidation.

Critical to achieving rapid evaporation and burnout is establishing a suspended phase of sludge droplets. This means that sludge must be atomized into droplets small enough to be suspended in the flow. On the other hand, atomization must avoid imparting excessive ballistic energy that can cause the droplets to impinge on the combustor walls. Because the sludge nozzles require large orifice diameters in order to pass solid particles, atomization is essential. With large orifices, 3.2 lpm of water would flow in a cohesive stream. On the isothermal model, this stream was seen to breakup in the swirling air but did not produce a suspended droplet phase and water impinged heavily on the upper and lower walls. To avoid this impingement finer droplets are required and this is achieved by atomization. A minimum atomization level was needed to generate fine droplets

corresponding to an air to water mass ratio of 7 percent and an air pressure of 70 kPa (10 psig). A compromise between droplet size and jet momentum is required to avoid over driving the fluid and impinging the sludge on the far wall of the combustor. To further reduce jet momentum, a minimum of two injectors was considered. With two injectors the maximum levels of atomization that still avoided impingement was a 15 percent air to water mass ratio and 250 kPa air pressure. Under these conditions, the injectors produced a finely atomized spray of suspended droplet with little wall impingement. The use of two injectors will also conceivably reduce temperature stratification in the suspension zone.

Two nozzle spray angles were also evaluated. A wide spray angle (60°) nozzle caused excessive upper and lower wall wetting that was expected to cause problems during hot operation. Sludge impinging on the walls will cause cold local wall temperatures that can spread due to poor gas to liquid heat transfer at the wall. This would in time lead to a failure mode. A narrow spray angle nozzle on the other hand was shown to be relatively effective in producing a suspended mist of droplets. The preferred nozzle had a 20 degree full spray angle. Additionally the injection angle for sludge was also evaluated. Like with fuel injection, the sludge injection is more radial than the air to avoid throwing the sludge against the walls. Three injection angles were considered at -25° , 0° and $+25^\circ$ from radial. From the isothermal model it was clear that the -25° injection which is slightly counter flow caused poorer suspension of droplets. No obvious difference was observed for the other two injection angles.

Engineering assessments of the droplet retention, evaporation and burnout times, indicated that the maximum droplet size target for the injectors was approximately $300\ \mu\text{m}$. Larger droplets could fall out of suspension and could lead to a failure mode. Smaller droplets are desirable however impinging the spray on the walls must be avoided. Work has begun on evaluating these injector specifications on the full-scale combustor but the effort has been limited to a single fuel injection configuration with two sludge injectors of the following specification: spray angle 20° , injection angle 30° . Under this configuration, complete evaporation of the water was not accomplished. Additional modifications to the VCC have been proposed and will be evaluated during the continuation of this project.

CONCLUSIONS AND FUTURE ASSESSMENT

The initial efforts of the program were successful in identify operating conditions for the VCC and converting the unit to fuel oil operation. The emission performance was very good and stable combustion was achieved with target levels of sludge injection.

Currently testing with the specified sludge injector under fuel oil operation has not optimized the integration of sludge injection. The initial tests were conducted with a single fuel injector and two sludge injectors and as such uniform thermal conditions were not produced. Operation with a single fuel injector demonstrated the "proof-of-concept" for combustion stabilization. Future plans will evaluate multi-point fuel injection, narrower sludge spray angles and different sludge injection angles. Further diagnostic efforts are planned that include detailed temperature mapping to identify potential impingement or condensate locations.

Initial performance of the combustor, showed the capacity to produce effective combustion of both natural gas and fuel oils with low levels of CO emissions. Combustion is stable and emissions were not deteriorated by water injection. In fact the lower temperature of combustion reduced thermal NOx formation and overall NO levels were 60 ppm (corrected to 7% O₂). Ultimately, these levels of performance must be maintained when firing real sludge wastes. Based on the engineering assessment of droplet evaporation and particle conversion times and the available

retention time in the high temperature oxidizing environment, excellent performance should be maintained.

REFERENCES

- 1 Schadow, K.C., Hendricks, E.W., and Hansen, R.J., "Recent Progress in the Implementation of Active Combustion Control." 18th ICAS Congress, Beijing, China, September 1992.
- 2 Parr, T.P., Gutmark, E.J., Wilson, K.J., Hanson-Parr, D.M., Yu, K., Smith, R.A., and Schadow, K.C., "Compact Incinerator Afterburner Concept Based on Vortex Combustion," Twenty-Sixth International Symposium on Combustion. pp. 2471-2477. Naples, Italy. 1996.
- 3 Parr, T.P., Wilson, K.J., Schadow, K.C., Cole, J.A., Widmer, N.C. and Seeker Wm.R., "Actively Controlled Afterburner for Compact waste incinerator." Proceedings of the International Conference on Incineration and Thermal Treatment Technologies. Orlando, Florida. 1999.
- 4 LaFond, J.F. and Payne, R., "Development of a Coal Burning Vortex Containment Combustor," Proceedings of the Second Annual Pittsburgh Coal Conference, 1985.
- 5 Parr, T.P., Wilson, K.J., Smith, R.A., Schadow, K.C, Widmer, N.C., Cole, J.A., and Seeker Wm.R., "Sludge Combustor Using Swirl and Active Combustion Control." Presented at the 19th International Conference on Incineration and Thermal Treatment Technologies. Portland, Oregon, 2000.

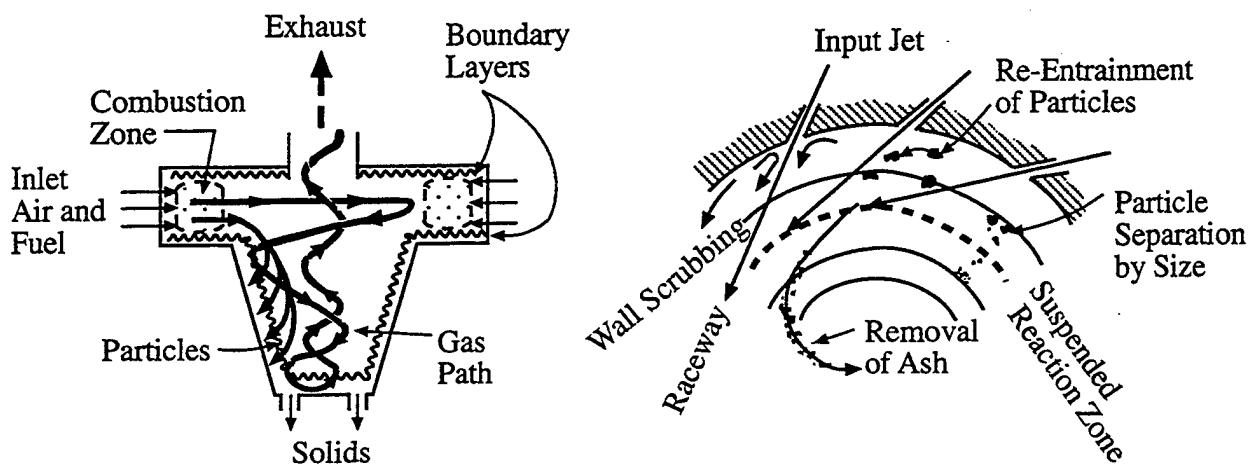

Fig. 1. Conceptual operation of the vortex containment combustor showing the top view of the suspended reaction zone (right) and the side view of the overall gas and particle paths (left).

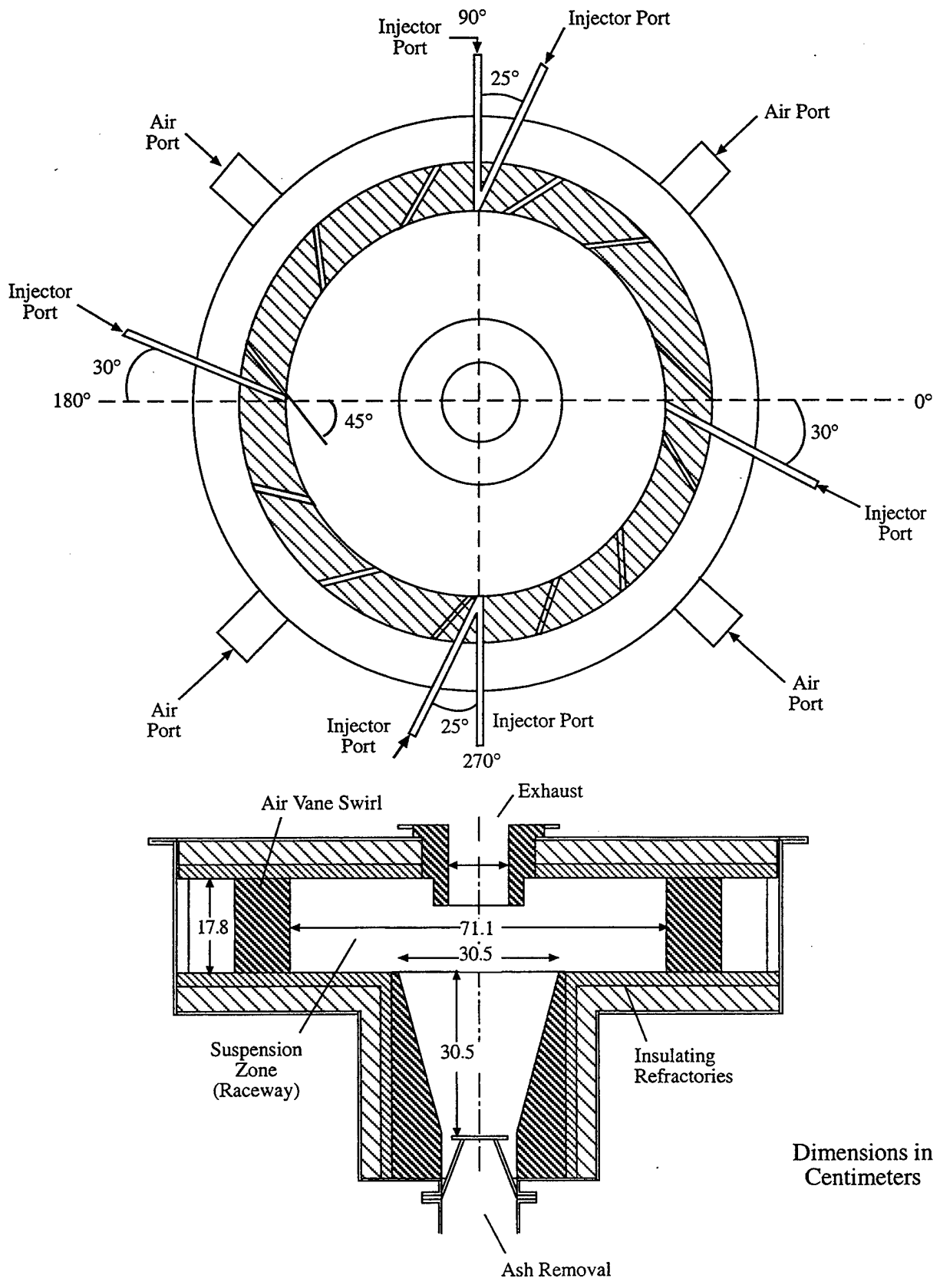

Fig. 2. Details of the full-scale VCC dimensions and internal layout. The top view illustrates the injector and air port locations (above). The insulation and internal dimensions are shown in the side view (below).

Configuration	Injection Characteristics		Water Injection, lpm					
	Location	Description	0.63	1.3	1.9	2.5	3.2	3.8
Unstabilized		NG, one 1/2" dia. injector Water, one injector	X	X	X	0		
		NG, two 3/4" dia. injector Water, one injector	X	X	0			
		D.O., air atomized nozzle Water, one injector	X	X	0			
		D.O., pressure nozzles Water, two injectors	X	X	X	0		
Stabilized		NG, one 1/2" dia. injector Water, two injectors	X	X	X	X	X	X
		D.O., air atomized nozzle Water, two injectors	X	X	X	X	X	X

X - Stable
 0 - Flame Out

Fig. 3. Flame stability map as a function of water injection for various injection configurations.

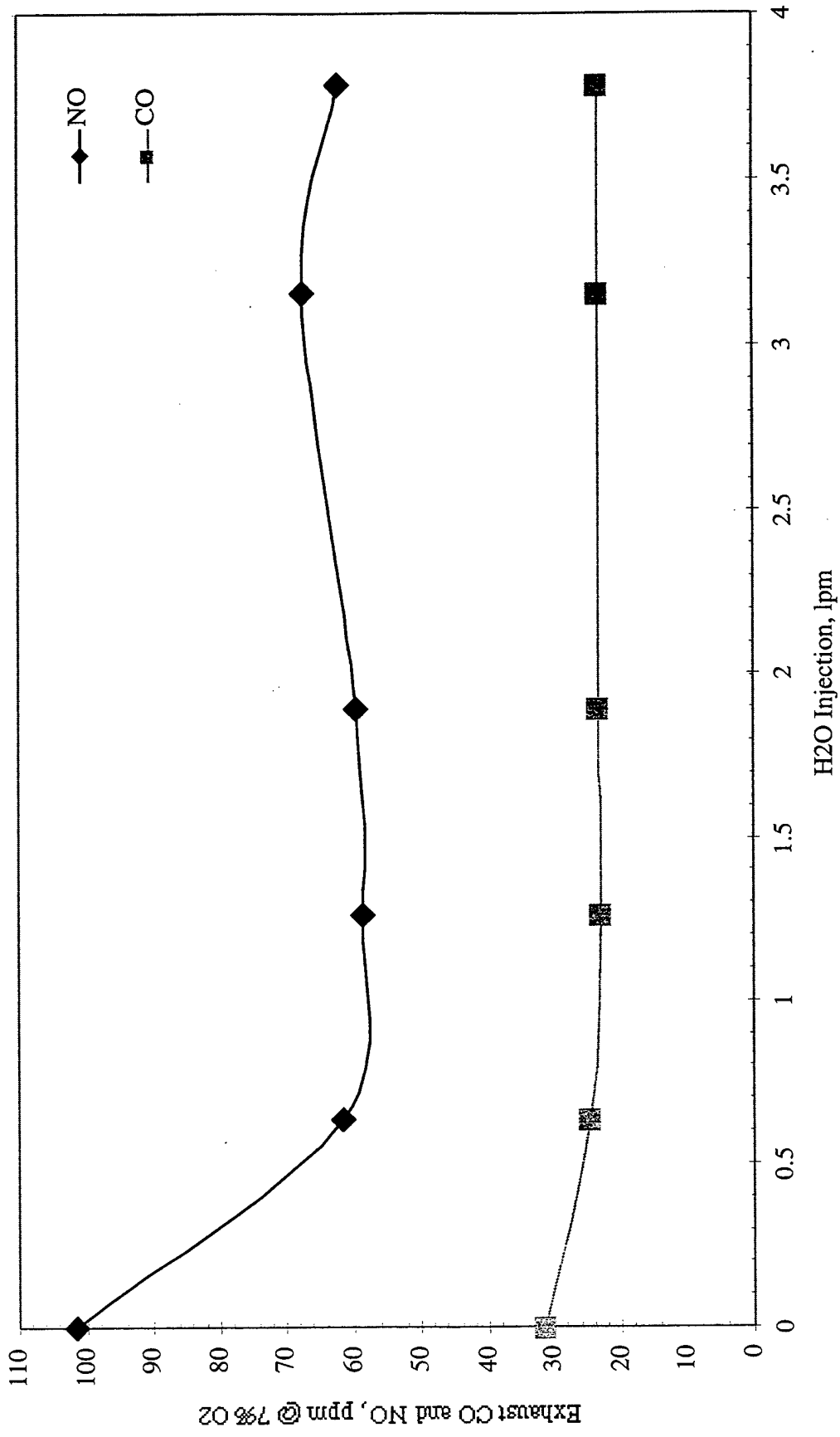

Fig. 4. Illustrations of CO and NO exhaust emissions for the VCC operating at 500 kW.

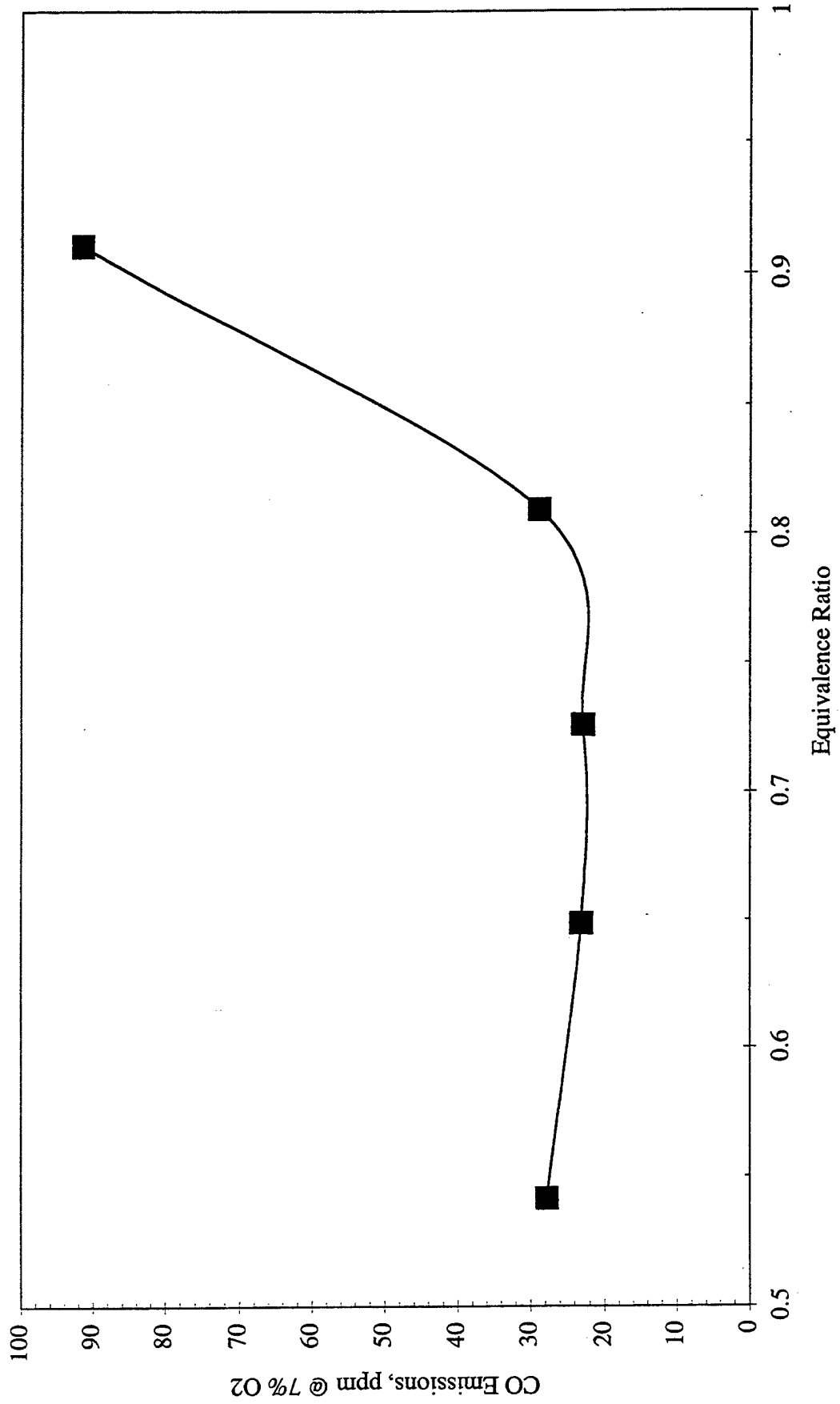

Fig. 5. Illustration of VCC exhaust CO emissions at various equivalence ratios. The VCC was fired at 500 kW with 1.9 lpm of sludge water injection.

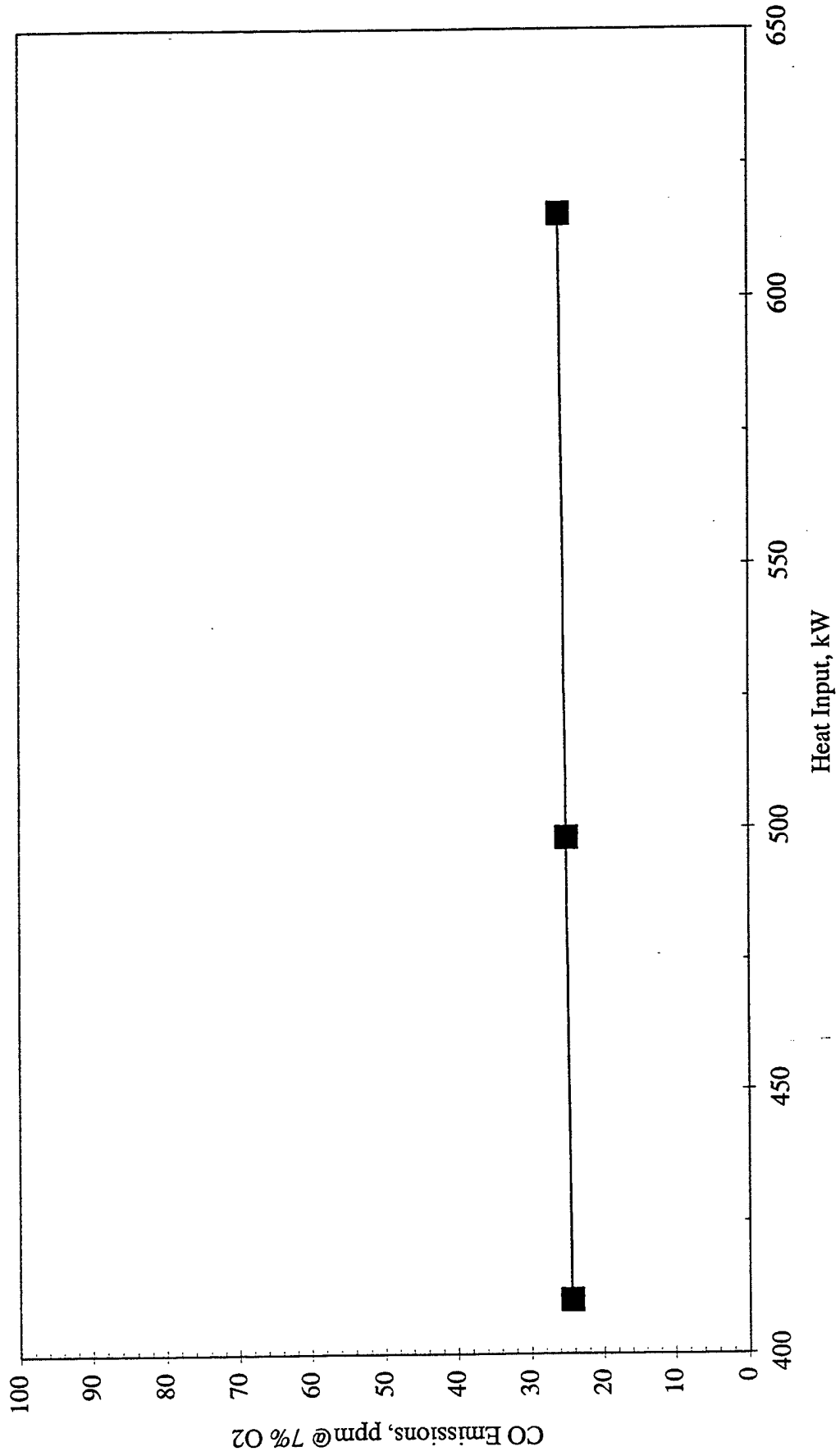

Fig. 6. Illustration of VCC CO exhaust emissions operating at various heat input. The VCC equivalence ratio was 0.69 and sludge water injection was 1.9 lpm.

NEIL C. WIDMER

GE Energy and Environmental Research Corporation
Project Manager

EDUCATION: B.S. Mechanical Engineering, 1990
University of California, Davis

SUMMARY: Project Manager in Research and Technology Group. Project Manager of Navy acoustic combustor program. Assistant manager for 4 projects under the multi-million dollar Unmixed Reformer Program. Principal investigator on Solar Detoxification of Soils program and managed SITE Emerging Technology Program for volatile metals removal from contaminated soils. Principle investigator on several bench scale research studies for mercury removal technologies and mercury behavior studies. Design Engineer for experimental and industrial facilities. Engineered development of gas reburning processes for municipal waste incinerators and utility boilers. Managed electrostatic precipitator research and development programs.

EXPERIENCE:

Mr. Widmer is currently leading a project team for the Navy Vortex Afterburner and Acoustic Incineration program. Mr Widmer is responsible for design, testing and evaluation of acoustically enhance combustion systems for waste thermal treatment.

Mr. Widmer is assisting the management of a multi-million dollar program to convert fuel to hydrogen for PEM fuel cell applications. The program is comprised of several projects sponsored by DOE, CEC, AQMD and GE.

Mr. Widmer was principal investigator on a 1.5 million dollar solar reactor program designed to process volatile and semi-volatile chlorinated organics extracted from contaminated soils. Mr. Widmer's responsibilities included supervising design, construction, installation and testing on this pilot-scale facility demonstrated in June 1997.

Mr. Widmer also managed a program developing a technology to capture and remove volatile metals from flue gases utilizing high temperature fabric filtration and sorbent injection. The program involved the design of a high temperature (1800°F) filter vessel and process development. Mr. Widmer led the design effort and supervised construction, operation and testing.

Mr. Widmer has been involved in several bench and pilot-scale process development and research studies. Mr. Widmer is currently assisting in the bench-scale development of hydrogen reforming and gas purification processes and has conducted bench scale experiments in mercury-sorbent capture technologies and fundamental mercury behavior studies.

Mr. Widmer's designed the Burner Engineering Research Laboratory (BERL) furnace located at Sandia National Laboratory, Livermore, California. This facility is a 3 MMBTU/hr industrial scale experimental furnace equipped for in-flame laser diagnostics and conventional diagnostics.

Mr. Widmer conducted several studies on bench through industrial-scale facilities. As test engineer, he was responsible for design, operation, testing, measurement systems, data reduction and analysis and reporting.

Refereed Articles:

N.C. Widmer, J.A. Cole, W.R. Seeker and J.A. Gaspar . **Practical Limitation of Mercury Speciation in Simulated Municipal Waste Incinerator Flue Gas**, Combust. Sci. and Tech. 1998, 134, (1-6), 315-326.

Cole, J.A., Hansell, D.W., Widmer, N.C., Seeker, Wm. R., Wilson, K.J., Parr, T.P., and Schadow, K.C. "U.S. Navy Combats Shipboard Incineration and Waste Disposal Problems" Environmental Science and Engineering. September 1997.

Presentations/Conference Proceedings:

Widmer, N.C., and Cole, J.A. **The Reactor Filter System: Air Toxics Control for Soil Thermal Treatment Processes.** *Presented at:* U.S. EPA 5th Forum on Innovative Hazardous Waste Treatment Technologies: Domestic and International. Chicago, IL. May 3 - 5, 1994.

Rooney, G., Widmer, N.C., and Cole, J.A. **The Reactor Filter System for Multi-Pollutant Control.** *Presented at:* The AWMA Specialty Conference on Fabric Filters. Toronto, Ontario, September 1994.

Widmer, N.C., Cole, J.A., Ho, L. **Demonstration of Solar Detoxification of Chlorinated Waste Compounds from Soils.** *Presented at:* Emerging Technologies in Hazardous Waste Management VI (Industrial and Engineering Chemistry Special Symposium, American Chemical Society). Atlanta, GA. September 19 - 21 1994.

Widmer, N.C., Cole, J.A. **The Reactor Filter System: Air Toxics Control for Soil Thermal Treatment Processes.** *Presented at:* Emerging Technologies in Hazardous Waste Management VI (Industrial and Engineering Chemistry Special Symposium, American Chemical Society). Atlanta, GA. September 19 - 21 1994.

Widmer, N.C., Cole, J.A., Koppang, R.R., Gemmer, R.V., and Gensler, W. **Advanced Diagnostic Evaluation of an Ultra-Low NOx Industrial Gas Burner.** *Presented at:* American Flame Research Committee 1995 Fall International Symposium. Monterey, CA. October 15 - 18 1995.

Sheldon, M.S, Cole, J.A., Widmer, N.C., and Koppang, R.R. **Analysis of Emissions Formation in an Industrial Fuel-Staged Burner.** *Presented at:* Western States Section/The Combustion Institute 1996 Spring Meeting. Arizona State University, Tempe Arizona. March 11, 12 1996.

Cole, J.A., Hansell, D.W., Widmer, N.C., Seeker, Wm. R., Wilson, K.J., and Parr, T.P. **Forced Acoustic Field Effects on Incineration Processes: Research on U.S. Navy Shipboard Waste Disposal.** Paper 97S-043. *Presented at:* Western States Section/The Combustion Institute 1997 Spring Meeting. Sandia National Laboratories, Livermore, California. April 13, 14 1997.

Widmer, N.C., Hansell, D.W., Cole, J.A., and Seeker, Wm. R. **Application of Acoustic and Design Enhancement to Onboard Naval Waste Thermal Treatment Facilities** Presented at the Fifth International Congress on Toxic Combustion Byproducts. University of Dayton, Dayton, OH, June 25 - 27, 1997.

Widmer, N.C., Hansell, D.W., Cole, J.A., and Seeker, W.R. **Acoustic Enhancement of Navy Blackwater Sludge Incinerator.** Paper 97F-115. *Presented at:* Western States Section/The Combustion Institute 1997 Fall Meeting. South Coast Air Quality Management District, Diamond Bar, CA. October 23, 24 1997.

Widmer, N.C., Cole, J.A., Seeker, W.R., Wilson, K.J., Parr, T.P., Schadow, K.C. **Scale-up and Operation of an Acoustically Stabilized Dump Combustor.** Paper 99F-61. *Presented at:* Western States Section/The Combustion Institute 1999 Fall Meeting. University of California, Irvine, CA. November 8, 9 1999.