

## Confined Disposal Facility (CDF) Containment Features: A Summary of Field Experience

**PURPOSE:** Confined disposal facilities (CDFs) are one of the most widely used technologies for managing contaminated sediments. The effectiveness of a CDF in containing contaminants depends on the design, construction, operation, and management of the facility. This technical note describes field experiences with the application of containment features to improve the effectiveness of CDFs in retaining contaminants in the CDFs and reducing the potential for contaminant losses to surface water, groundwater, air, plants, and animals.

**BACKGROUND:** A CDF is an engineered structure designed to provide the required storage volume for dredged material and to meet the required suspended solids in effluent released from the facility. Procedures for design of CDFs for storage volume and for suspended solids retention are provided in Engineer Manual 1110-2-5027 (Headquarters, U.S. Army Corps of Engineers 1987). A CDF may be constructed as an upland site, as a nearshore site with one or more sides exposed to the water, or as an island containment area. Typical CDF configurations are illustrated in Figure 1.

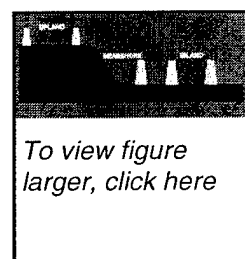

To view figure  
larger, click here

Figure 1

The joint U.S. Army Corps of Engineers (USACE) and U.S. Environmental Protection Agency (USEPA) document "Evaluating Environmental Effects of Dredged Material Management Alternatives—A Technical Framework" (USACE/USEPA 1992) provides evaluation guidance for selecting an appropriate dredged material disposal alternative and further provides procedures for identifying contaminant loss pathways requiring control measures necessary for any disposal alternative. Figure 2, extracted from the framework document, shows various pathways and control measures that may be considered to enhance containment or to reduce contaminant losses for each pathway of concern. Control measures for CDFs providing containment of contaminants, not treatment, are the focus of this technical note. Field experiences related to containment features retrofitted for existing CDFs and containment features designed as an integral part of new CDFs are described.

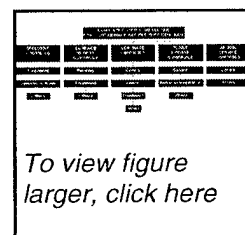

To view figure  
larger, click here

Figure 2

**DESCRIPTION OF CONTAINMENT APPROACHS:** Contaminant loss pathways for a CDF are illustrated in Figure 3; these pathways include effluent, surface runoff, leachate, dike seepage, volatilization, plant uptake, and animal uptake. When environmental standards or guidelines are not met for one or more of these pathways, contaminant control measures can be considered to reduce impacts to acceptable levels. Control measures may consist of treatment of sediments or pathway releases or operational or engineered containment measures, or both. Containment in a CDF may be defined as an operational approach or engineered feature intended to function as a contaminant control measure to reduce the migration or transport of contaminants via one of the pathways.

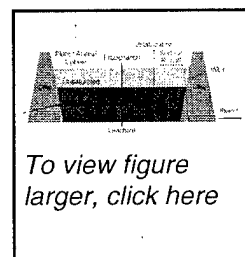

To view figure  
larger, click here

Figure 3

Containment refers to the ability of the site with associated design features to hold the contaminants within the site as opposed to treatment approaches intended to destroy or degrade contaminants or chemically (not physically) immobilize the contaminants within the sediment. Control measures may include operational modification, selective placement of dredged material, engineered site controls or containment features, and other site management actions (USACE/USEPA 1992).

**Operational Controls.** Site operations can be used as a control measure for CDFs to reduce the loss of contaminants through the surface water, volatilization, and leachate pathways. Operational controls may include management of ponded water on the site during and after disposal operations. Mobilization of some contaminants from dredged material depends on a variety of factors, including the oxidation state of the chemical species. Most metals are much less mobile when maintained in an anaerobic and reduced condition. On the other hand, oxidizing conditions tend to favor aerobic biodegradation of organic contaminants. Moist, exposed sediments generally present the greatest potential for volatilization of organic contaminants. Ponded conditions that normally exist in nearshore and in-water CDFs can limit volatilization. Water depth also may affect plant and animal uptake. Maintaining ponded water on the site produces a hydraulic gradient that increases the potential for movement of leachate through the site. Plant and animal propagation affects contaminant uptake. Management of the site for contaminant controls both during filling and after dredged material placement requires a comprehensive understanding of the migration pathways and the effects various operations have on the overall mass balance and rate of contaminant releases (USACE/USEPA 1992). Oftentimes, trade-offs are required to balance effectiveness and cost and to reduce environmental risk to acceptable levels. Operational techniques for CDFs that have been used for contaminant control include:

- Placement sequencing or sandwiching: filling the CDF with alternating layers of clean and contaminated material to provide for attenuation (sorption, ion exchange, filtration, biodegradation, etc.) or containment of contaminants.
- Self-sealing/self-lining: taking advantage of the fine-grained nature of dredged material, which yields low permeability when subjected to consolidation in a CDF.
- De facto covers: placing dredged material with suitable chemical and physical properties as the final layer in a CDF.
- Drainage layers: placement of sand layers to enhance dewatering and consolidation.
- Control of ponded water to reduce hydrostatic head or maintain a negative hydraulic gradient (conditions causing seepage flow into the CDF as opposed to flow from the CDF).

**Selective Placement Configurations and Sequencing.** Selective placement is the placement of contaminated sediments within the CDF where contaminants remain relatively immobile or the placement of clean dredged material to intercept or attenuate contaminant migration from contaminated dredged material. Selective placement configurations with respect to water levels are possible for nearshore and in-water CDFs. Selective placement below the groundwater or surface water elevation keeps that portion of the CDF fill anaerobic, which reduces the potential for release of some classes of contaminants of concern (especially metals) to the dissolved phase. Selective placement can also take the form of configuring the CDF fill with a greater depth and smaller surface area. This technique reduces the "footprint" of the site subject to erosion, plant and animal uptake,

and surface runoff. However, the design surface area and depth must also consider effects on effluent quality.

Large CDFs have been constructed in The Netherlands, and the design of several of these sites has included selective placement configurations. Descriptions of the general design aspects, environmental features, and monitoring data for several large CDFs constructed in The Netherlands have been recently published (Nijssen et al. 1997; Laboyrie, Kamerling, and de Haan 1995; Laboyrie, Flach, and van der Laan 1997; Heineke, Eversdijk, and Kevelam 1997; Hartnack, van Steenwijk, and Steenkamp 1997; Flach, Driebergen, and Godefrooij, 1997; de Haan, Kamerling, and Laboyrie 1995). The largest sites are the Slufter and the Ijsseloo sites, but several others are in the planning or design stages.

Highly contaminated dredged material may be selectively placed below the mean tide level (MTL) elevation, with cleaner dredged material or other capping material placed above the MTL mark (de Haan, Kamerling, and Laboyrie 1995; Heineke, Eversdijk, and Kevelam 1997).

Prudent site selection, placement sequencing, and site management have therefore been used to ensure adequate containment of contaminants (Laboyrie, Kamerling, and de Haan 1995; de Haan, Kamerling, and Laboyrie 1995). Special contaminant control measures such as bottom liners have seldom been used because they require nonconventional construction methods, and their cost is prohibitive.

**Self-Sealing Properties of Fine-Grained Dredged Material.** Dredged material is initially pumped into a CDF at high water content, but quickly settles to a condition approaching that in the channel prior to dredging. Over time, the newly placed material begins to consolidate. Measured permeabilities of dredged material at 50 percent of primary consolidation range from  $8.5 \times 10^{-10}$  to  $4.1 \times 10^{-7}$  cm/sec (Bartos 1977). This range of permeability is comparable to that required for liners in licensed solid waste landfills ( $1 \times 10^{-7}$  cm/sec). Therefore, the initial layers of a fine-grained dredged material selectively placed in the bottom layers of a CDF will begin to “self-seal” as consolidation progresses, and will continue to seal as more layers of dredged material are placed over the older layers.

**Engineered Containment Features.** Engineered CDF containment features or control measures are specifically designed and constructed to enhance containment of the dredged material and control potential contaminant release pathways. Such site controls include surface covers, liners, slurry walls, sheetpile cutoff walls, low permeability dikes or dike cores, permeable filtration dikes, reactive dike designs, leachate collection systems, and other containment or mitigation features. Engineered containment features, illustrated in Figure 4, may include:

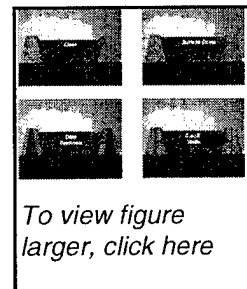

Figure 4

- **Soil liners:** a layer of soil, usually clay, in the bottom and dikes of a CDF to reduce seepage of leachate out of the facility. Clay liners can be constructed using clean dredged material or other suitable construction fill.

- **Synthetic liners:** a flexible geomembrane liner in the bottom and on the inside face of the CDF dikes.
- **Surface covers:** a layer of material placed on top of contaminated sediment to reduce access by plants and animals, or to reduce infiltration of precipitation into the fill, thereby reducing leachate volume.
- **Dike cores:** dikes constructed using a layer or core of material that reduces permeability to retard seepage.
- **Cutoff walls:** installation of a barrier, e.g., a slurry wall or sheetpile, to reduce leachate flow from the CDF or to divert groundwater around the CDF.
- **Wick drains:** promotion of dewatering and consolidation by providing for subsurface drainage using vertical wicks—reduces hydraulic conductivity throughout the depth of the CDF.
- **Reactive barriers:** dikes constructed using a layer of material that provides for treatment of seepage by filtration, sorption, biotreatment, or other means.
- **Combinations of active and passive techniques:** in situ treatment, including biological, chemical, and electrochemical/electrokinetic processes, as well as pump and treat techniques, are innovations that may be combined with containment measures for additional control if required.

**SUMMARY OF FIELD EXPERIENCES (CASE STUDIES):** Containment features are not widely practiced for dredged material management because simply retaining sediment solids in a CDF has adequately met regulatory requirements for most navigation dredging projects. However, CDFs are often recommended and have been required for some sites receiving highly contaminated material or for sites located in environmentally sensitive areas. This technical note summarizes a number of case studies, both foreign and domestic. Many of the case studies contain only minimal information because no detailed design documents or data are available. In some cases, the detailed design reports that may exist are in other languages and only summaries are available in English. Table 1 lists the sites and containment features or measures, and descriptions of the designs and construction methods used for each site are given in the paragraphs that follow.

**Chicago CDF Liner.** The Chicago area CDF is a 170,000-sq-m nearshore site located in Calumet Harbor, Chicago, IL. This CDF is the first known site for contaminated dredged material in which a synthetic liner was placed in-water (Savage 1986). The CDF was constructed with a rubble mound dike with a core of prepared (graded) limestone. Graded limestone dikes have been used at a number of CDFs in the Great Lakes region. The limestone material in the dike core was composed of a grade commonly referred to as 10 centimeter minus. Such dikes were designed to allow for flow of lake water through the dike in the initial stages of filling, with the dike “plugging” as filling progressed. A synthetic membrane liner was placed along the inside face of the dike to prevent excessive migration of fine dredged material solids through the prepared limestone dike core as the CDF was filled. A dike cross-section is illustrated in Figure 5. The liner was constructed in 60-m-long sections. The liner material was a flexible plastic of 30-mil thickness with polyester fabric

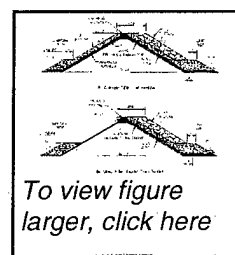

Figure 5

**Table 1  
Summary of CDFs with Containment Features (after Palermo and Averett 2000)**

CDF Site Name/ Location	Setting/Size/ Capacity	Containment Feature	Comments	References
Bremen, Germany	Upland dewatering cells 100 by 300 m	Liner	Dewatered dredged material liners, 0.3 m thick, with overlying drainage layer for dewatering	PIANC <sup>1</sup> (1997)
Calumet Harbor, Chicago, IL	Nearshore 17 ha	Partial liner	30-mil plastic liner placed on inside face of dike (damaged during placement); dredged material blanket repair	Savage (1986)
Dalhousie and Liverpoole, Canada	Nearshore	Clay dike core	Clay core placed between temporary sheetpiles	Personal communication, Jim Osborne, Environment Canada
Eagle Harbor, WA		Liner/cover	Selective placement below raised groundwater level; 60-mil HDPE <sup>2</sup> liner; surface cover 1.5 m (5 ft) select fill	Verduin et al. (1998)
Geuzenhoek, Ghent, Belgium (multi-cell CDF)	Upland with subcontainments 500,000 cu m	Liners; cutoffs	2 mm HDPE bottom liner with 0.4-m drainage layers; cement-bentonite slurry wall to 22 m depth; 100-mm-diam collection pipes at 7.5-m spacing	Flemish Ministry of Environment and Infrastructure (1994); Van den Eede (1994)
Geuzenhoek, Ghent, Belgium (research pilot cells)	Six cells with control 2,000 cu m	Adsorptive liners	1) 20 cm glauconite, 2) 30 cm bentonite with 30 cm subsoil, 3) 20 cm dewatered dredged material, 4) 40 cm peat, 5) sediment treatment with alumino-silicates, no liner, and 6) control cell, no liner or treatment	Flemish Ministry of Environment and Infrastructure (1994); Van den Eede (1994)
Hamburg, Germany	Upland dewatering cells 2-3 ha	Liner	Dewatered dredged material liners, with overlying drainage layer for dewatering	PIANC (1997)
Ijsseloo, Lake Ketelmeer, The Netherlands	Island 21 million cu m	Operational controls; liner	Selective placement below water level; hydrostatic head control; 1-m-thick clay bottom liner; geomembrane dike liner	Heineke, Eversdijk and Kevelam (1997)
Michigan City, MI	Upland 1.3 ha	Surface cover	60 cm clay, 60 cm subgrade fill, with topsoil, planted grass	USACE Chicago District (1987), (1989a)

**(Continued)**

<sup>1</sup> PIANC = Permanent International Association of Navigation Congresses.

<sup>2</sup> HDPE = high-density polyethylene.

<b>Table 1 (Concluded)</b>				
<b>CDF Site Name/ Location</b>	<b>Setting/Size/ Capacity</b>	<b>Containment Feature</b>	<b>Comments</b>	<b>References</b>
Minamata Bay, Japan		Surface cover	Fiber cloth, net of ropes hand-placed from boats, compacted by an 80-cm sand layer placed hydraulically, 1-m layer of volcanic ash soil, spread using dozers	PIANC (1997); Kumanoto Prefecture (1998)
Mission Bay, Thunder Bay, Ontario Canada	Nearshore multi-cell 81 ha	Cover	Clean topsoil cover	Public Works Canada (Ontario Region) (1991)
Monroe Harbor, MI	Nearshore	Dike layer	Grout mattress with clay seal layer	Personal communication, Doug Zande, Detroit District
New Bedford Harbor, MA	Nearshore; Superfund 7,600 cu m	Liner/cover	Synthetic liner; synthetic cover for volatiles control	Otis (1994)
Parrot's Beak Rotterdam, The Netherlands	Upland 40 ha	Dike liner, dike core	2-mm HDPE liner; 100-mm leachate collection pipes at 50-m spacings	Rotterdam Port Authority (1986)
Penns Grove, NJ	Upland 136 ha	Slurry wall	Bentonite, 9-18 m (30-60 ft) depth, 3,400 m (11,000 ft) total length	USACE Philadelphia District (1981)
Sitcum/Milwaukee Waterway, Tacoma, WA	Nearshore 327,000 cu m	Cover	Selective placement below water level; Surface cover, clean dredged material, 2 m (7 ft) thickness	Gilmur and Saathoff (1994)
Sunny Point, NC	Upland	Slurry wall	18 m depth	Personal communication, Mr. Les Wyatt, USACE Wilmington District
Terminal 3, Seattle, WA	Nearshore	Cover	Sand and gravel layer placed by conveyor and dozers	Boatmand and Hotchkiss (1997); Converse Consultants (1992)
Tresse Island Venice, Italy	Reconstructed solid waste landfill	Liner/cover	Polyurethane-sealed sheetpile cutoffs to -10 m; partial dredged material liner; partial bentonite slurry wall to -8 m	Consortio Venezia Nuova (1997)
Waukegan Harbor, IL	Nearshore Superfund	Cutoff walls	Double sheetpile cutoff wall and clay slurry wall	USEPA GLNPO (1998)

reinforcement. The sections were heat welded in the field. The membrane was laid directly on the inside face of the dike using a roller arrangement mounted on a barge (see Figure 6). As the barge was moved along the inside face of the dike, the membrane was fed from the roller. Stones were used to anchor the membrane in place as the work progressed.

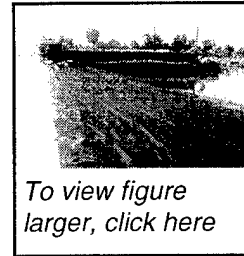

Figure 6

Observations of fluctuating lake levels during and following construction indicated that the liner was ineffective in retarding flow of water through the dike section (there was no appreciable lag in lake water level fluctuations inside the dike). A dye study showed that the liner was perforated randomly throughout its length due to tears or punctures during placement. These tears likely resulted from random punctures from the angular limestone core underneath or the armor stone placed on top of the liner.

Several corrective actions were considered, including grouting and slurry walls. The selected corrective action was placement of a sand blanket along the inside face of the dike. Sandy material was excavated directly from the lake bottom within the CDF and placed on the inside dike face at a 1V on 3H slope. The sand was initially dredged from within the CDF via a small crane barge. Later, because the sand above the water line was eroded by rainfall, additional sand was hauled in from an outside source and placed with a "creter crane" from the top of the CDF dike. The creter crane is a conveyor that could be boomed out over the designated sand fill areas. This equipment, normally used to place concrete, is mobile and has a large conveyor feed box into which trucks dumped the sand after backing along the dike to the crane. Following placement of the sand blanket, comparison of water level fluctuations within the CDF with lake levels indicated that the blanket was effective in retarding flow through the dikes. Short-term fluctuations were retarded, but the water level in the CDF followed long-term lake level fluctuations with a lag.

Subsequent to placement of the sand blanket, the Chicago District placed fine-grained dredged material along the inside face of the dike using a chute arrangement (Figure 7) to further seal the dike. The dredged material was re-handled from barges using a clamshell and placed on the chute, sliding down to the inside face of the dike at the water level. As the work progressed, the chute was moved laterally along the dike until the work was completed.

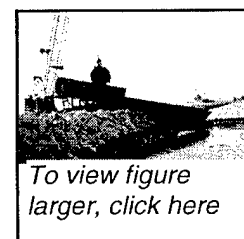

Figure 7

**New Bedford Harbor Superfund Liner and Cover.** A 7,600-cu-m CDF with a synthetic liner and a synthetic cover was used for containment of PCB-contaminated sediments removed from the "hot spot" of this Superfund site (PCB = polychlorinated biphenyl). The CDF had been previously constructed along the New Bedford shoreline to contain the contaminated sediments removed during an earlier pilot study of dredging equipment. The facility was modified and used again during the hot spot remedial action. The modifications included dividing the facility into three cells to facilitate the water treatment process, installation of a high density polyethylene geomembrane liner, and installation of a floating cover over the large cell into which the dredged material was initially pumped to control volatilization. The purpose of the liner was to contain excess water produced during hydraulic dredging and leachate during storage of the dredged material. Groundwater monitoring around the site has not detected any contaminant leakage. The cover for the site was installed because of concerns over volatilization of PCBs during filling. Dredged material was

pumped under the cover during filling, and volatile emissions from this component of the remediation system were adequately controlled.

**Eagle Harbor West CDF Liner and Cover.** A 0.4-ha nearshore CDF was used for placement of material dredged from the Eagle Harbor, WA, West Harbor Operable Unit, a part of the Wycoff/Eagle Harbor Superfund site. A plan and typical cross-sections for this site are shown in Figures 8 and 9, respectively. This site utilized selective placement of contaminated material below the water table and an engineered liner and cover (Verduin et al. 1998). The containment berm was constructed using select fill (40 percent gravel; less than 5 percent fines) placed by conveyor between riprap training dikes. Soft materials were removed from below the dike prior to its construction by excavating a key trench. A 60-mil HDPE liner was placed over the footprint of the CDF to an elevation of +10.0 mean lower low water (MLLW) to raise the water table from +6.0 MLLW to allow for additional volume retained in a saturated condition. Edges of the liner were overlapped a minimum of 0.3 m (1 ft) and the upper edge of the liner was anchored in a trench excavated into the inner side of the dike. Geotextile fabric was used on the inside face of the dike to cushion the liner from damage from the sharp edges of the training dike riprap. "Ecology blocks" were used to anchor the liner in place prior. Dredged material was placed in the CDF mechanically by clamshell equipment and front-end loaders. A surface cover of 1.5 m (5 ft) of compacted structural fill was placed to bring the fill to grade.

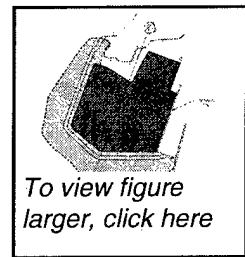

Figure 8

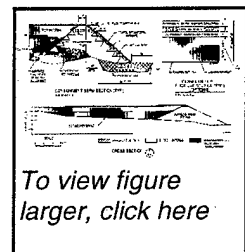

Figure 9

**Bremen and Hamburg, Germany, CDF Covers, Liners, and Leachate Collection.** Since the middle 1980's a concept of integrated dredged material disposal has been implemented at the ports of Bremen and Hamburg, Germany, involving dewatering and separation of dredged material and disposal of dewatered material in "silt mounds." Several million cubic meters of material are dredged each year, most of which is contaminated to some degree. Sediments that are predominantly fine-grained are placed in dewatering fields, while those with a significant fraction of sand (presently about 50 percent) are sent to mechanical dredged material processing plants. The separated sand is used beneficially, while the dewatered silt, from both the separation plants and dewatering fields, is placed in the silt mounds.

A series of 15 small CDFs are used as dewatering fields at the Port of Bremen. Following placement and dewatering in these facilities, the dredged material is re-handled to an upland CDF for final disposal. Each of the dewatering fields is about 100 by 200 m and is used annually to dry approximately 700,000 cu m of wet dredged material. An aerial view is shown in Figure 10 (PIANC 1997). The fields were constructed on an older CDF using the previously placed dredged material. During construction, the bottoms and the slopes were covered with a sealing liner of 0.30 m of conditioned dredged material. Drainpipes were installed in a sand layer above the sealing layer to collect percolating water and discharge it to another pond for treatment.



Figure 10

The silt mounds themselves are essentially upland CDFs, acting as covers constructed over previously used conventional CDFs. A double seal liner is installed at the base of the silt mound (essentially on top of the old CDF), consisting of 2.5-mm-thick HDPE, heat-sealed, with a 1.5-m-thick layer of compacted silt. Dewatered dredged material is placed in layers with intermediate layers of separated sand acting as drainage layers. A double seal is also installed as a cover layer, with a topsoil layer for planting a vegetative cover. A cross-section of this arrangement is shown in Figure 11.

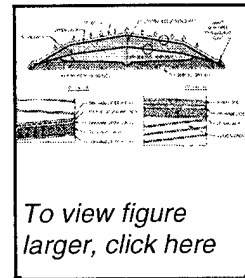

To view figure larger, click here

Figure 11

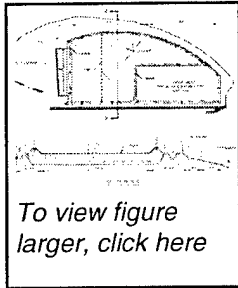

To view figure larger, click here

Figure 12

**Parrot's Beak, Rotterdam CDF Liner and Leachate Collection:** The Papegaaiebek (Parrot's Beak) site in Rotterdam, The Netherlands, is a 40-ha upland CDF specially designed for highly contaminated dredged material from Rotterdam Harbor. The site has been filled with approximately 1.5 million cubic meters of fine-grained material, and hydraulic pipeline dredges or hydraulic off-loaders were used for the filling. A plan view of the site and a typical cross-section of the dike used are shown in Figure 12.

This CDF was designed with a liner and leachate collection system. The liner for Parrot's Beak consisted of 2-mm-thick HDPE sheeting. The liner material was placed in overlapping strips (see Figures 13 and 14), extending across the bottom of the basin and onto the inside face of the dike. A crane was used to unroll the strips, which were then held in place with sandbags. The edge of the liner was anchored in a trench excavated along the dike crest (Figure 15). Seams were then heat-welded (Figure 16). The leachate collection system consisted of 100-mm-diam perforated pipe placed at 50-m spacings.

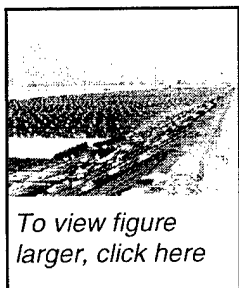

To view figure larger, click here

Figure 13

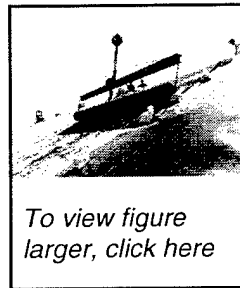

To view figure larger, click here

Figure 14



To view figure larger, click here

Figure 15



To view figure larger, click here

Figure 16

Once dredged material was initially placed in the site, an inner compartment was constructed for the most highly contaminated sediment, separated from the remainder of the CDF by an interior filtration dike. Clean fine-grained dredged material was used to form the main berm for the interior dike and was left in a layer above the membrane within the interior compartment. The upper portion of the interior dike section consisted of a sand core with geotextile placed on the inside face which acted as a filter for excess water flowing from the interior compartment to the main CDF.

**Venice Lagoon CDF "Diaphragm" Liner and Cover.** A confined site with special lateral containment measures was constructed as a part of the overall remediation of the Venice, Italy,

Lagoon (PIANC 1996, Consorzio Venezia Nuova 1997, Bernstein 1999 (Personal communication, 1999, Alberto Giulio Bernstein, The Tresse Island Rehabilitation Project, Head of the Consorzio Venezia Nuova Environmental Department.). A portion of the contaminated sediments was too contaminated to be recycled for the reconstruction of marshes, and therefore was placed in a lined and covered CDF on Tresse Island. This site was formerly used for the deposit of urban and solid waste, and the containment measures were designed to isolate both the existing waste materials and future dredged materials from the Venice lagoon waters. The isolation from the lagoon has been achieved by the use of a reconstructed perimeter dike system. A cross-section of a portion of the perimeter dike system is shown in Figure 17. Rock-fill berms with concrete topping were constructed on the sides of the island exposed to wave action due to ship traffic. Sheetpiling sealed with polyurethane was driven to a depth of -10 m into a thick, low-permeability soil layer to form a vertical cutoff. Dry material was placed in a lined fill immediately landward of the sheetpile. A secondary dike was constructed further landward with the liner incorporated into the dike cross-section. In areas not exposed to ship traffic, a simpler "plastic diaphragm" consisting of mixture of water, cement, and bentonite was constructed with a thickness of 0.5 m and to a depth of -8 m, reaching clay layers to form a vertical cutoff. The entire perimeter system was covered with topsoil and will be revegetated and planted with trees. The sealed perimeter dikes resulted in a large area suitable for placement of new material dredged from canals and channels. Tresse Island is designed to hold a total of 700,000 cu m of dredged material. Once filled, the site will be covered with a clay layer to allow for revegetation.

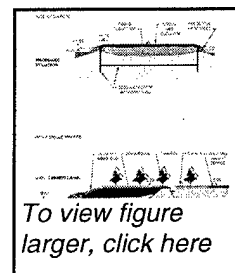

Figure 17

**Ijsselooog CDF Liner.** The Ijsselooog CDF is a large island CDF constructed in Lake Ketelmeer in The Netherlands. The site is designed to store approximately 21 million cubic meters of contaminated material and incorporates several containment features and operational strategies (Heineke, Eversdijk, and Kevelam 1997). The site was constructed in an area with existing bottom contamination; therefore, temporary storage facilities for this material were required, and the material was later re-handled into the completed CDF.

The configuration of the CDF was selected as a circular fill, consisting of a 40-m-deep excavated pit, surrounded by a 10-m-high ring dike. This high fill with minimal surface area would maximize consolidation resulting in a low permeability fill, and would minimize contact area with groundwater flows. A 1-m-thick clay layer was placed in the bottom of the constructed subaqueous pit. Fine-grained sediments underlying the ring dike were left in place (except for the contaminated surficial layer) so that a low-permeability layer would remain beneath the dike. A seepage cutoff layer was constructed in the under/inner part of the ring dike with a geomembrane to prevent seepage from inside the CDF to surrounding surface water.

The water level within the CDF will be maintained at the same level as the hydraulic head in the CDF foundation (-4.5 m) until the CDF fill reaches -8 m. The same strategy will be used once consolidation brings the contaminated fill level again below -8 m. Note that a synthetic liner was considered in the early design stages, but the environmental impact assessment (EIA) for the site concluded that a liner was not necessary because of the high cost and difficult placement conditions. Further, the EIA concluded that the failure of a liner within the period of 25,000 years after placement

was high. Subsequent to publication of the EIA, it was agreed to include a placed clay liner (Flach, Driebergen, and Godefrooij 1997).

**Geuzenhoek, Belgium, CDF Liners, Leachate Collection, and Cut-off Walls.**

A 500,000-cu-m capacity CDF at Geuzenhoek was constructed adjacent to the Ghent seacanal for placement of contaminated material and has been used as a field research site for comparison of the effectiveness of a range of liner materials (Flemish Ministry of Environment and Infrastructure 1994) (Figure 18). Several large compartments were constructed in the early 1990's, each with differing containment measures. The first compartment was constructed with a 2-mm HDPE liner, and two 0.4-m-thick sand drainage layers, one above and one below the liner. The liner was damaged during placement, and several portions of the liner had to be replaced. Weather conditions were found to affect the heat-welding process, and concerns with sunlight degradation prevented placement during mid-day sunny conditions. Placement of protective layers of sand exposed the liner to heavy loadings, and the protective layer could not be placed on the inside face of the dikes. Cost of the liner was also excessive, causing the cost of maintenance dredging to almost triple. To avoid these problems, other containment options were incorporated into the next two compartments. A "thin wall" cement-bentonite slurry wall was used as a cutoff. This wall had a thickness of 10 cm, a maximum depth of 22 m, and a reported permeability of  $10^{-8}$  m/sec. This option was found to have several advantages: (1) problems with liner damage and degradation were avoided, (2) the working principle of the slurry wall relies on both reduced permeability and the adsorptive capacity of the bentonite, (3) in case of leakage, a new section of wall can be constructed to solve the problem and, (4) the cost was approximately 30 percent that for a liner. The final option for isolation included a drainage system consisting of 100-mm pipes spaced 7.5 m to drain off excess water.

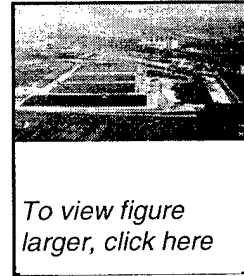

Figure 18

In addition to the containment options used in the larger compartments, a field research program was undertaken at the Geuzenhoek site to evaluate cost-effective isolation measures. Six upland cells were constructed each with a capacity of 2,000 cu m, with each cell used to test a different bottom layer. These layers were not designed as sealing layers, but as active bottom layers with a capacity for adsorption and cation exchange. The options evaluated included: (1) glauconite liner, laid down as a granular material to 20 cm thickness, (2) bentonite liner, placed as a mixture with natural subsoil to 30 cm thickness, (3) dewatered dredged material liner, mechanically dewatered and chemically conditioned and placed in a 20 cm thickness, (4) peat placed at 40 cm thickness, (5) full sediment treatment with alumino-silicates mixed prior to placement, and (6) a control cell with no liner or treatment. A seventh subaqueous cell was constructed with a vertical cutoff or vertical waterproof foil screen. The cells were instrumented with piezometers and sampling wells; a laboratory-testing program was conducted on samples from the cells, and tracer tests were conducted. Dredged material was hydraulically placed in the cells with care taken to ensure that materials with the same physical and chemical properties were placed in each cell. The glauconite and bentonite could be successfully placed on the side slopes of the cells, but peat had to be kept moist. Each cell was therefore filled with water following construction and prior to placement of dredged material. It was determined that the dewatered dredged material should be placed and compacted at a water content wetter than optimum, slopes should not be steeper than 1V on 2H, the material should be protected against drying by covering with a thin sand layer, and the sand layer in turn should be protected against erosion by a geo-jute. The permeability of the dewatered dredged

material liner in situ was found to be two orders of magnitude higher than measured in the lab, and a value of  $10^{-7}$  m/sec was considered the best feasible value in situ. Tracer experiments indicated a 20- to 50-day migration period through the isolation layers and into the drainage system. Volume of percolating water was high at first but diminished rapidly due to consolidation and clogging. The volume of water was 1.5 to 3.0 times greater for peat and glauconite than for bentonite or dewatered dredged material. Sealing capacity of all tested materials, including the control cell with no bottom layer, was of the same order of magnitude. Mobility of most contaminants in leachate was low; the exceptions were nitrogen, sulfates, and nitrates, which are not bound on the solid phase. The general conclusion from these field tests was that, except for highly contaminated materials, impermeable or adsorptive layers are not needed for CDFs. Rather, efficient drainage systems should be considered, so that levels of contaminants in percolating water can be monitored and treated if necessary.

**Michigan City CDF Cover.** The Michigan City CDF is a small 13,000-sq-m upland site. The site contains about 40,000 cu m of dredged material contaminated with metals, PCBs, and petroleum products. Dikes were constructed of compacted earth fill with a sand filter dike section intended to allow for filtered discharge of effluent during filling. Initially, dredged material was placed in the CDF hydraulically, but the filter section became clogged. Subsequent operations were accomplished using mechanical dredges with re-handling to trucks for placement in the CDF (Richardson, Chaney, and Demars 1996). After the last dredged material placement, the site was fully dewatered and had naturally vegetated. Desiccation cracks in excess of 0.3 m deep were evident on the dredged material surface (USACE Chicago District 1987, 1989a).

Monitoring well data had indicated concern with potential ammonia releases to adjacent surface waters, and a surface cover was placed at the site to reduce infiltration. The cover consisted of 0.6 m of clay and 0.6 m of subgrade fill and topsoil planted with grasses. The cap was designed using USEPA's Hydrologic Evaluation of Landfill Performance (HELP) model. Regrading and compacting the site to cover the vegetation and form a 30-cm-thick subgrade layer prepared the surface. The initial clay cap material was initially stockpiled by trucks along the dike crowns, spread by bulldozers, and compacted with a roller (Figure 19). The topsoil layer was placed in a similar manner and then seeded (USACE Chicago District 1989b).

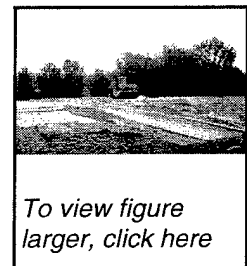

Figure 19

**Minamata Bay CDF Cover.** The Minamata Bay, Japan, project was a large-scale project involving the construction of a CDF for remediation of mercury-contaminated sediments (PIANC 1997, Kumamoto Prefecture 1998). A portion of the bay was enclosed with a line of sheetpile cofferdam revetments (see illustration and cross-section in Figures 20 and 21). A 1-m-thick sand layer was first placed along the cofferdam footprint to reduce sediment resuspension. A second layer of sand with additional provisions for sand compaction and sand drains was placed to provide a suitable foundation for construction of the cofferdams.

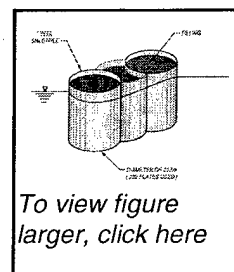

Figure 20

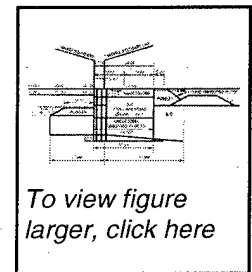
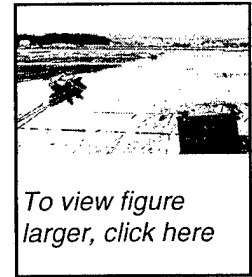

Figure 21

The enclosed area was subsequently filled with contaminated sediment dredged from the remaining portion of the bay with a cutterless pipeline dredge. To avoid volatilization of mercury, a water pond of at least 50 cm was maintained over the dredged material during the filling operations. After the completion of dredging, a surface cover of soil was placed over the reclaimed sediment for confinement. It was intended that the cover be placed under overlaying water; however, the sediment surface was too soft to be covered with clean soil directly with equipment, and measures were needed to stabilize the sediment to improve trafficability and bearing capacity. This was accomplished by first placing a synthetic fiber cloth and a net of ropes by workers in boats maneuvered by cables (Figure 22). Once the fiber cloth and rope net were placed, the dredged material was compacted by an 80-cm layer of sand placed hydraulically. A 1-m-thick layer of volcanic ash earth of low specific gravity (1.1 in the air) was then spread using small bulldozers.



*To view figure larger, click here*

Figure 22

**Terminal 3 Seattle CDF Cover.** Several nearshore CDF sites in the Puget Sound, WA, region have been capped with clean material and converted to container facilities or parking areas (Palermo et al. 2000; Boatman and Hotchkiss 1997; Converse Consultants 1992). One example is the Terminal 3 site in Seattle which was capped upon completion of the CDF fill. The specification for the cap material was for select structural fill to support the pavement section. The material was likely sand and gravel from a nearby quarry. The contractor placed the initial lift of material using a conveyor (Figure 23). After several meters (feet) were placed in this manner, the remaining cap section was pushed into place with dozers (Figure 24).

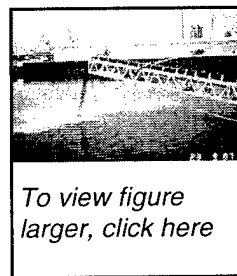

*To view figure larger, click here*

Figure 23

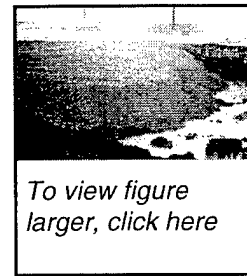

*To view figure larger, click here*

Figure 24

**Sunny Point CDF Slurry Wall.** A slurry wall was constructed at an upland CDF on the U.S. Army facility at Sunny Point, NC (Figure 25). This slurry wall was required to control saltwater intrusion into a sand aquifer underlying the site. Water was ponded to within 1.8 to 2.4 m of the dike crest and held at that level, presumably to maintain good water quality for the effluent discharge. However, this produced a static head, resulting in saltwater intrusion into the aquifer, which eventually impacted a number of large and historic trees on property adjacent to the CDF. This was a nontypical groundwater intrusion problem, in that the contaminant of concern was chloride (salinity), which is highly mobile, and does not adsorb to dredged material or foundation soil particles, as do most contaminants of concern found in sediments.

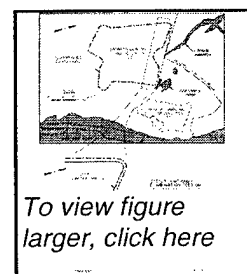

*To view figure larger, click here*

Figure 25

A cutoff slurry wall was constructed along the land side of the CDF near the dike toe to correct this problem. The wall was constructed to a depth of approximately 18 m using a long reach backhoe and a “traveling slurry pond.” A grout mixture was prepared in a bermed pond, and the backhoe excavated sections of the wall within the bermed pond, allowing the grout to fill in the trench as excavation progressed. Slurry was added and the pond was “shifted” to travel along the slurry wall alignment until the wall was completed. The completed width of the slurry wall is 0.6 to 0.9 m.

Once the wall was completed, wells were pumped on the outside of the wall to recover chloride plumes down gradient from the wall. Piezometer data indicated that the groundwater flow was reversed, and the pumping drained several small ponds. Pumping was therefore discontinued when the majority of the plume was recovered (Personal communication, Les Wyatt, Wilmington District, 1999, Chief, Design Section, Engineering Branch, Technical Services Division).

**Penns Grove CDF Slurry Wall.** A slurry wall was constructed at the Penns Grove CDF located adjacent to the Delaware River near Penns Grove, NJ (USACE Philadelphia District 1981). This 136-ha CDF was sited on an extensive sand and gravel foundation. Private contractors mined sand and gravel for resource recovery and creation of additional disposal capacity within the CDF prior to any placement of dredged material under a lease agreement with the Philadelphia District. This operation removed large portions of the surficial silts and clays, exposing the underlying aquifer to potential infiltration of leachate from the CDF. The mining operation was terminated when leachate effects were identified as a potential problem.

A cutoff slurry wall was subsequently constructed outside the disposal area dikes and exterior drainage trench as shown in Figure 26. The trench had a minimum width of 1 m (3 ft) and was cut to depths of 9 to 18 m (30 to 60 ft) and keyed into an impervious clay layer underlying the site. A mixture of 70 parts sand, 30 parts silt, and 2 parts bentonite was used. The total length of trench was approximately 3,400 m (11,000 ft), extending generally around two sides of the CDF. Silt layers are intact along the remaining two sides that would substantially reduce infiltration. Monitoring wells were also installed. This site has not yet been used for dredged material placement.

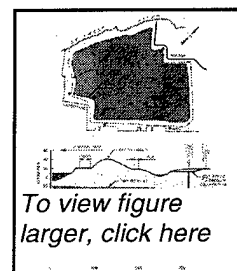

Figure 26

**Monroe Harbor CDF Dike Mattress.** A grout mattress was used at a CDF located at Sterling State Park to seal prepared limestone dikes. The goal was to make the CDF watertight because of concern for groundwater contamination due to PCB concentrations in the dredged material. The original design included a bentonite seal on the bottom and side slopes of the CDF. The bottom and most of the slope were to be under water because of the proximity to Lake Erie. The bentonite was removed from the design during a value engineering review due to the difficulty expected in placing the material under water. A grout mattress was substituted for the side slope, and additional clay was left on the bottom. The mattress was put in place, but it tended to float due to Lake Erie flowing into the CDF. To stop that from occurring, a clay seal was constructed on top of the mattress to hold it in place. The clay sealed the mattress and dike successfully. As with other CDFs with prepared limestone dikes, once dredged material is placed against the dike, it becomes watertight. The mattress's primary benefit is to prevent erosion on the side slopes until dredged material can be placed against the slopes (Personal communication, Doug Zande, Detroit District, 1999, Chief, Operations Technical Support Office).

**Waukegan Harbor (Outboard Marine Corporation Superfund Site) Dike Cutoff.** PCB-contaminated sediment from Waukegan Harbor was dredged hydraulically and placed in containment cells constructed in a boat slip and other nearshore areas. Design of these cells included a double sheetpile cutoff wall to isolate the slip from the harbor and a clay slurry wall that was

anchored to the underlying clay till (see Figure 27). The slip held approximately 23,000 cu m of contaminated sediment (USEPA GLNPO 1998).

**Mission Bay, Thunder Bay, Canada, CDF Dike Core/Surface Cover.** An 81-ha CDF in Thunder Bay, Canada, was specifically built for contaminated dredged material. A perimeter berm was constructed, incorporating a filter fabric and clay core. A “reservoir” cell was constructed for temporary placement of materials dredged mechanically and transported by scow. Four interior cells were constructed for permanent storage. The material is hydraulically rehandled from the reservoir cell to the permanent cells. Once filled, the permanent cells are graded, covered with a layer of clean topsoil, and seeded (Public Works Canada, Ontario Region 1991).

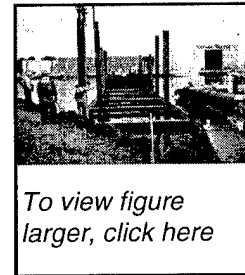

Figure 27

**CONCLUSIONS:** There are few CDFs where operational controls for containment or engineered containment features have been implemented. Most of these sites are associated with sediment remediation projects, which involve more highly contaminated sediments than normally associated with navigation projects. Selective placement of contaminated materials below the water table or water surface and maintenance of water levels within a CDF have been used as operational control measures. Engineered CDF containment features used to date include liners, surface covers, and dike or perimeter cutoffs for lateral seepage control. Contaminant control measures should be considered to reduce or control impacts due to a contaminant release that exceeds a set criteria or standard. However, in practice, many of the controls were implemented because of administrative or regulatory mandate, with no analysis to establish the need for the control.

Liners have been designed and incorporated as constructed features for only a few CDFs, and most of these were constructed in European countries. Materials used for liners have included synthetic membranes such as HDPE, compacted clay, and placed fine-grained dredged material of acceptable quality. Care should be taken to avoid damage during the placement of liner materials, especially for in-water sites.

Surface covers for CDFs have been constructed with imported topsoil, clean dredged material, and combinations of fabrics and soil layers. In many cases, cover materials may be placed directly over dredged material, which is still at high water content, although special equipment such as conveyers will be required to spread the initial layers.

Lateral seepage control features for CDFs include low-permeability dike cores constructed from clay, sheetpile cutoff walls within the dike cross-section, and synthetic membranes or grout mattresses placed on the inside face of the dike. Slurry walls have also been constructed along dike perimeters of the CDF.

Design of these containment features has been on a case-by-case basis with little commonality from site to site. Reports on effectiveness or criteria for evaluation of the measures are also poorly documented in the open literature. There are no specific designs or construction guidelines for engineered containment measures tailored to the conditions normally encountered with contaminated dredged material in CDFs.

The information in this technical note will be used in developing design and construction guidance for CDF containment features under the Dredging Operations and Environmental Research (DOER) Program. The field experiences with control measures for CDFs will be updated as more information becomes available.

**POINTS OF CONTACT:** For additional information, contact the authors, Dr. Michael R. Palermo (601-634-3753, [palermm@wes.army.mil](mailto:palermm@wes.army.mil)) or Mr. Daniel E. Averett (601-634-3959, [averetd@wes.army.mil](mailto:averetd@wes.army.mil)), or the Program Manager of the Dredging Operations and Environmental Research Program, Dr. Robert M. Engler (601-634-3624, [englerr@wes.army.mil](mailto:englerr@wes.army.mil)). This technical note should be cited as follows:

Palermo, M. R., and Averett, D. E. (2000). "Confined disposal facility (CDF) containment measures: A summary of field experience," *DOER Technical Notes Collection* (ERDC TN-DOER-C18), U.S. Army Engineer Research and Development Center, Vicksburg, MS. [www.wes.army.mil/el/dots/doer](http://www.wes.army.mil/el/dots/doer)

## REFERENCES

- Bartos, M. J., Jr. (1977). "Classification and engineering properties of dredged material," Dredged Material Research Program, Technical Report D-88-18, U.S. Army Engineer Waterways Experiment Station, Vicksburg, MS.
- Boatman, C. D., and Hotchkiss, D. A. (1997). "Tidally influenced containment berm functioning as a leachate treatment cell - Puget Sound experience in confined disposal of contaminated sediments," *International Conference on Contaminated Sediments*, Rotterdam, The Netherlands, 7-11 September 1997.
- Consorzio Venezia Nuova. (1997). "Measures for the protection of Venice and its lagoon," Consorzio Venezia Nuova, Concessionary of the Ministry of Public Works, Water Authority of Venice.
- Converse Consultants. (1992). "Final project report: Terminal 91 short fill monitoring program," Converse Consultants NW, Pacific Groundwater Group, Hall and Associates, Seattle, WA.
- de Haan, W., Kamerling, G., and Laboyrie, P. (1995). "Isolation in disposal sites for contaminated dredged material," *Proceedings, Fourteenth World Dredging Congress, Amsterdam, The Netherlands, 14-17 November 1995*. Central Dredging Association, Delft, The Netherlands, 723-730.
- Flach, E., Driebergen, J., and Godefrooij, J. (1997). "Environmental impact assessment for a disposal site in the Lake Ketelmeer Area, The Netherlands," *International Conference on Contaminated Sediments*, Rotterdam, The Netherlands, 7-11 September 1997.
- Flemish Ministry of Environment and Infrastructure. (1994). "Het proefstortenproject Geuzenhoek," Ministry of Environment and Infrastructure, Ports and Waterways Division, Flemish Government, Belgium.
- Gilmur, R. C., and Saathoff, D. D. (1994). "Sediment remediation and navigational improvements within the Port of Tacoma, Washington," *Proceedings, WEDA XV Technical Conference and 27th Annual Texas A&M Dredging Seminar, San Diego, CA, Texas A&M University, College Station, TX*.
- Hartnack, J., van Steenwijk, J., and Steenkamp, B. (1997). "Recommendations for environmental impact assessment on the disposal of contaminated dredged material in open and semi-closed disposal sites," *International Conference on Contaminated Sediments*, Rotterdam, The Netherlands, 7-11 September 1997.
- Headquarters, U.S. Army Corps of Engineers. (1987). "Confined disposal of dredged material," Engineer Manual 1110-2-5027, Washington, DC. <http://www.usace.army.mil/inet/usace-docs/eng-manuals/em1110-2-5027/toc.htm>
- Heineke, D., Eversdijk, P., and Kevelam, D. (1997). "Design of the Ijsseloog storage site," *International Conference on Contaminated Sediments*, Rotterdam, The Netherlands, 7-11 September 1997.
- Kumamoto Prefecture. (1998). "An outline of the environmental restoration of Minamata Bay," Kumamoto Prefecture.

- Laboyrie, P., Flach, B., and van der Laan, A. (1997). "Site investigations for the Ijsseloo confined disposal facility (CDF)," *International Conference on Contaminated Sediments*, Rotterdam, The Netherlands, 7-11 September 1997.
- Laboyrie, P., Kamerling, G., and de Haan, W. (1995). "The construction of large scale disposal sites for contaminated dredged material," *Proceedings, Fourteenth World Dredging Congress, Amsterdam, The Netherlands, 14-17 November 1995*. Central Dredging Association, Delft, The Netherlands, 709-722.
- Nijssen, J., Zwakhals, J., Ammerlaan, R., and Berger, G. (1997). "Monitoring environmental effects in the Slufter, a disposal site for contaminated sludge," *International Conference on Contaminated Sediments*, Rotterdam, The Netherlands, 7-11 September 1997, 623-630.
- Otis, M. J. (1994). "New Bedford Harbor, Massachusetts dredging/disposal of PCB contaminated sediments." *Dredging 94—Proceedings of the Second International Conference on Dredging and Dredged Material Placement*, American Society of Civil Engineers, 1, 579-587.
- Palermo, M. R., and Averett, D. E. (2000). "Summary of constructed CDF containment features for contaminated sediments," *Proceedings of the Western Dredging Association XX and Texas A&M University 32nd Annual Dredging Seminar*, CDS Report No. 372, Texas A&M University, College Station, TX, 447-456.
- Permanent International Association of Navigation Congresses (PIANC). (1996). "Handling and treatment of contaminated dredged material from ports and inland waterways - CDM," Report of Working Group No. 17 of the Permanent Technical Committee I, Permanent International Association of Navigation Congresses, Brussels, Belgium. (In two volumes, available on CD from PIANC <http://www.pianc-aipcn.org/pi200.html>)
- Permanent International Association of Navigation Congresses (PIANC). (1997). "Handling and treatment of contaminated dredged material from ports and inland waterways, CDM, Vol I and Vol II," Report of Working Group No. 17, Permanent Technical Committee I, Supplement to Bulletin No. 89, General Secretariat of PIANC, Brussels, Belgium.
- Public Works Canada, Ontario Region. (1991). "A study of the long-term use of confined disposal facilities (CDFs) in the Canadian Great Lakes." Public Works, Ontario Region.
- Richardson, G. N., Chaney, R. C., and Demars, K. R. (1996). "Design, performance, and monitoring of dredged material confined disposal facilities in Region 5 – Guidance document," Contract Report 68-CO-0068-43, Risk Reduction Engineering Laboratory, U.S. Environmental Protection Agency, Cincinnati, OH.
- Rotterdam Port Authority, (1986). "The storage of dredged sludge from the Lower Rhine delta," Rotterdam Public Works Department, Rotterdam Port Authority and Ministry of Transport and Public Works, The Netherlands.
- Savage, C. (1986). "Chicago area CDF synthetic liner and sand blanket experience," *A Forum to Review Confined Disposal Facilities for Dredged Materials in the Great Lakes*, Report of the Dredging Subcommittee to the Great Lakes Water Quality Board, Windsor, Ontario.
- U.S. Army Corps of Engineers Chicago District. (1987). "Michigan City maintenance dredging water quality monitoring results Report No. 1," Chicago, IL.
- U.S. Army Corps of Engineers Chicago District. (1989a). "Analysis report groundwater monitoring data: Michigan City confined disposal facility," Chicago, IL.
- U.S. Army Corps of Engineers Chicago District. (1989b). "Specifications for Michigan City confined disposal facility capping, Michigan City, Indiana," Solicitation No. DACW23-89-B-0007, Chicago, IL.
- U.S. Army Corps of Engineers Philadelphia District. (1981). "Delaware River, Philadelphia to the sea - Penns Grove disposal area, Penns Grove, New Jersey - Design of soil-bentonite slurry trench cutoff for aquifer protection," Philadelphia, PA.
- U.S. Army Corps of Engineers/U.S. Environmental Protection Agency. (1992). "Evaluating environmental effects of dredged material management alternatives - A technical framework," EPA842-B-92-008, U.S. Environmental Protection Agency and U.S. Army Corps of Engineers, Washington, DC. <http://www.epa.gov/OWOW/oceans/framework/>

- U.S. Environmental Protection Agency (USEPA). (1994). "Assessment and Remediation of Contaminated Sediments (ARCS) Program - Remediation guidance document," EPA 905-R94-003, U.S. Environmental Protection Agency, Great Lakes National Program Office, Chicago, IL. <http://www.epa.gov/glnpo/arcs/EPA-905-B94-003/EPA-905-B94-003-toc.html>
- USEPA GLNPO. (1998). "Realizing remediation, a summary of contaminated sediment remediation activities in the Great Lakes Basin," Chicago, IL. <http://www.epa.gov/glnpo/sediment>
- Van den Eede, E. (1994). "Treatment and disposal of dredged material, the Flemish experience," *Proceedings of CEEC-CEDA Course*, Catholic University of Louvain, Belgium.
- Verduin, J., Valentine, M., Patmont, C., Lally, J., Liikala, S., Gowdy, R., Whelan, M., and Singer, R. (1998). "Eagle Harbor West Harbor Operations Unit case study, the successful implementation of a contaminated sediment remedial action," *Proceedings 15th World Dredging Congress*, Vol II, Western Dredging Association, Vancouver, WA, 767-783.

**NOTE:** *The contents of this technical note are not to be used for advertising, publication, or promotional purposes. Citation of trade names does not constitute an official endorsement or approval of the use of such products.*

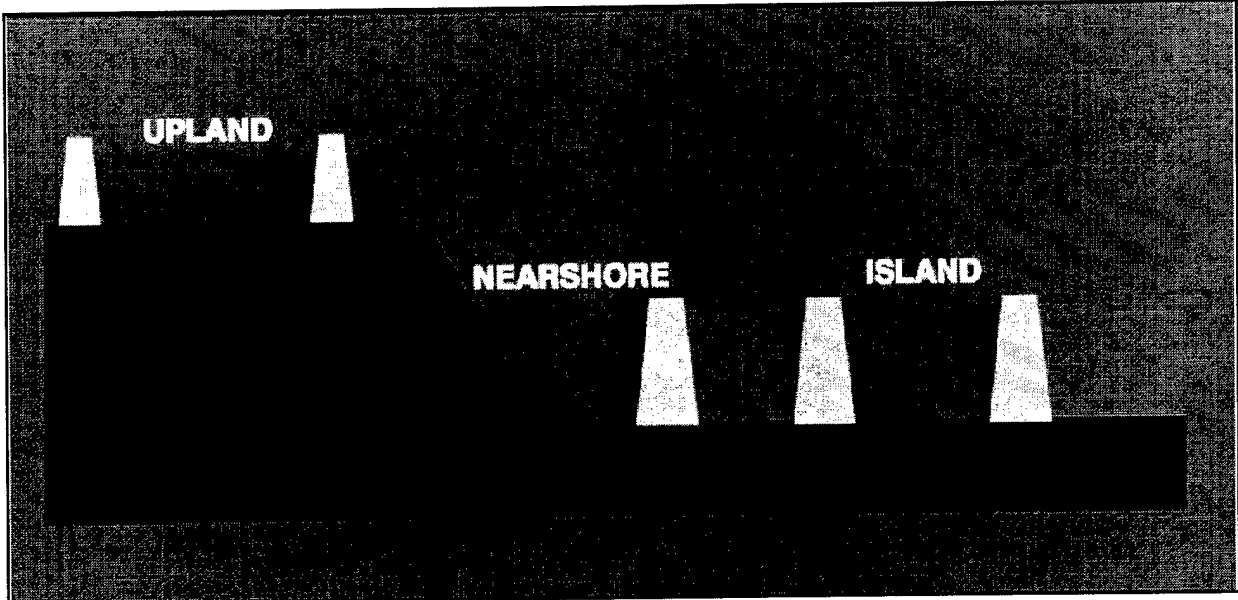

Figure 1. Upland, nearshore, and island (inter-tidal) CDF configurations

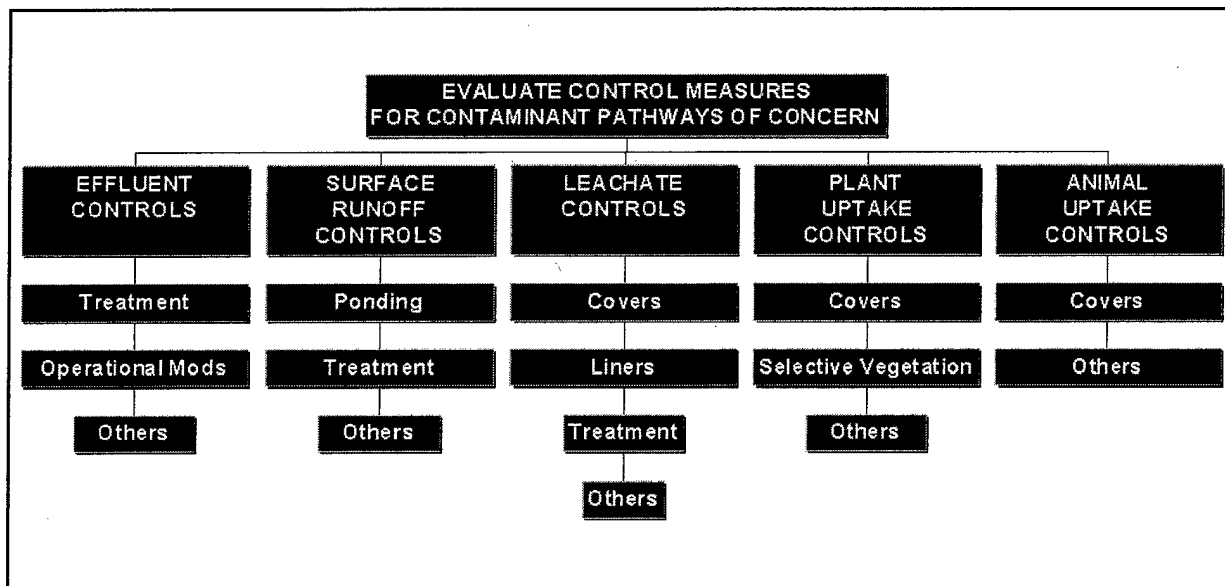

Figure 2. Framework for evaluation of pathways and control measures for CDFs (USACE/USEPA 1992)

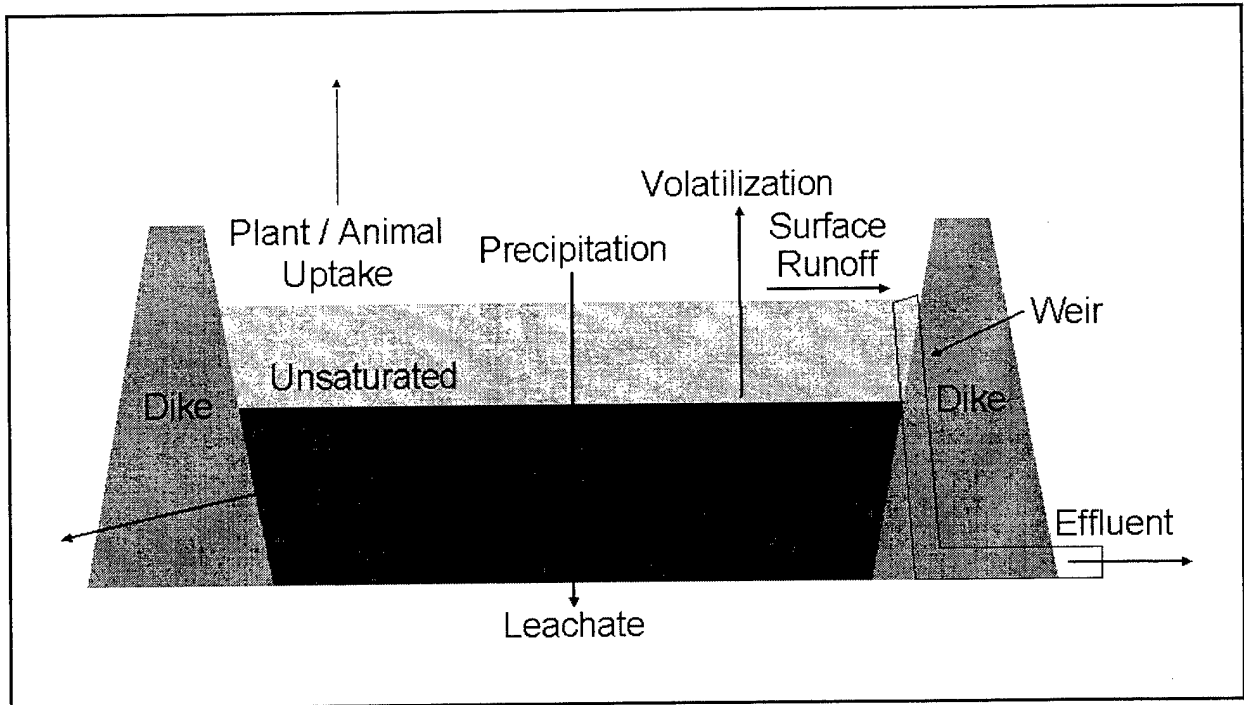

Figure 3. Contaminant loss pathways for an upland CDF

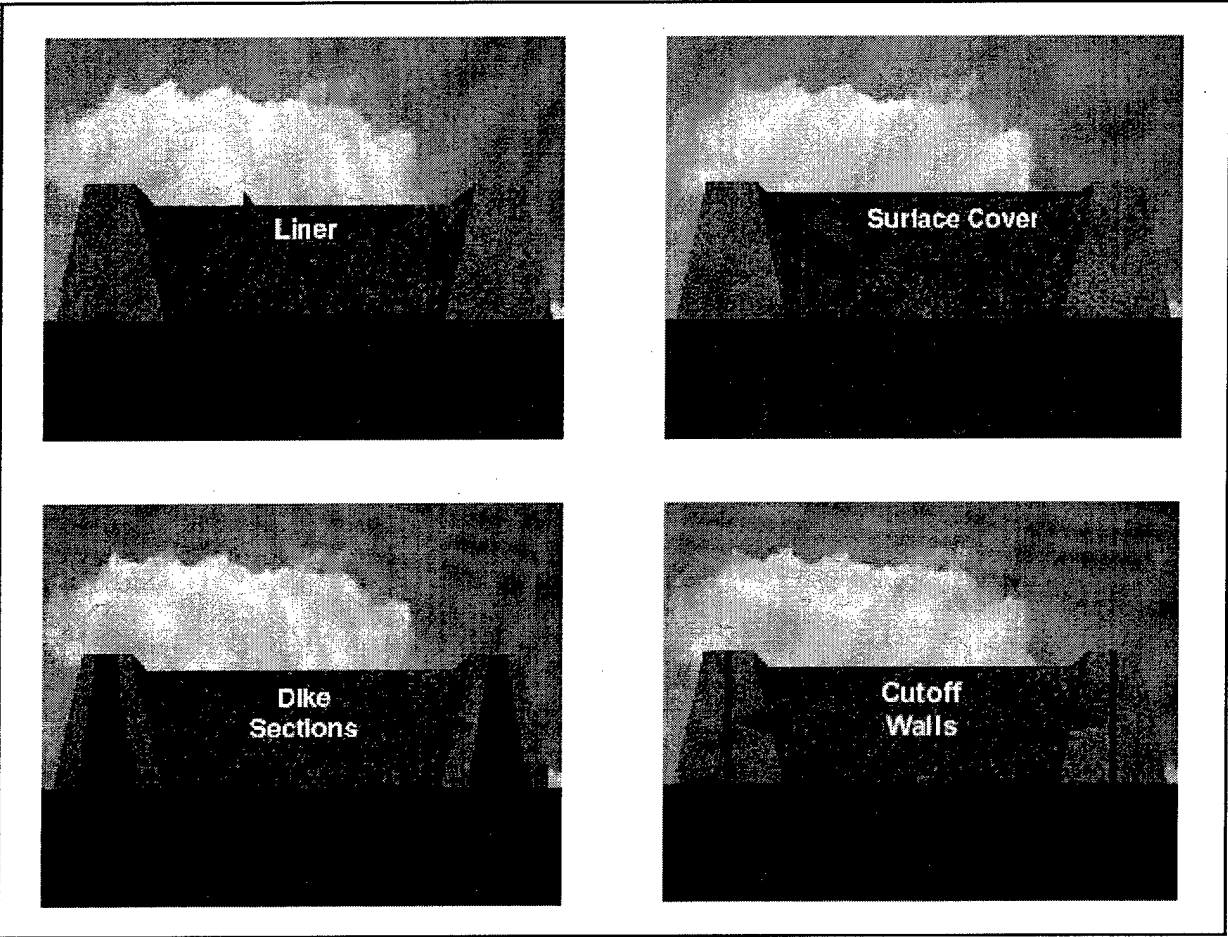

Figure 4. Schematic of CDF engineered controls

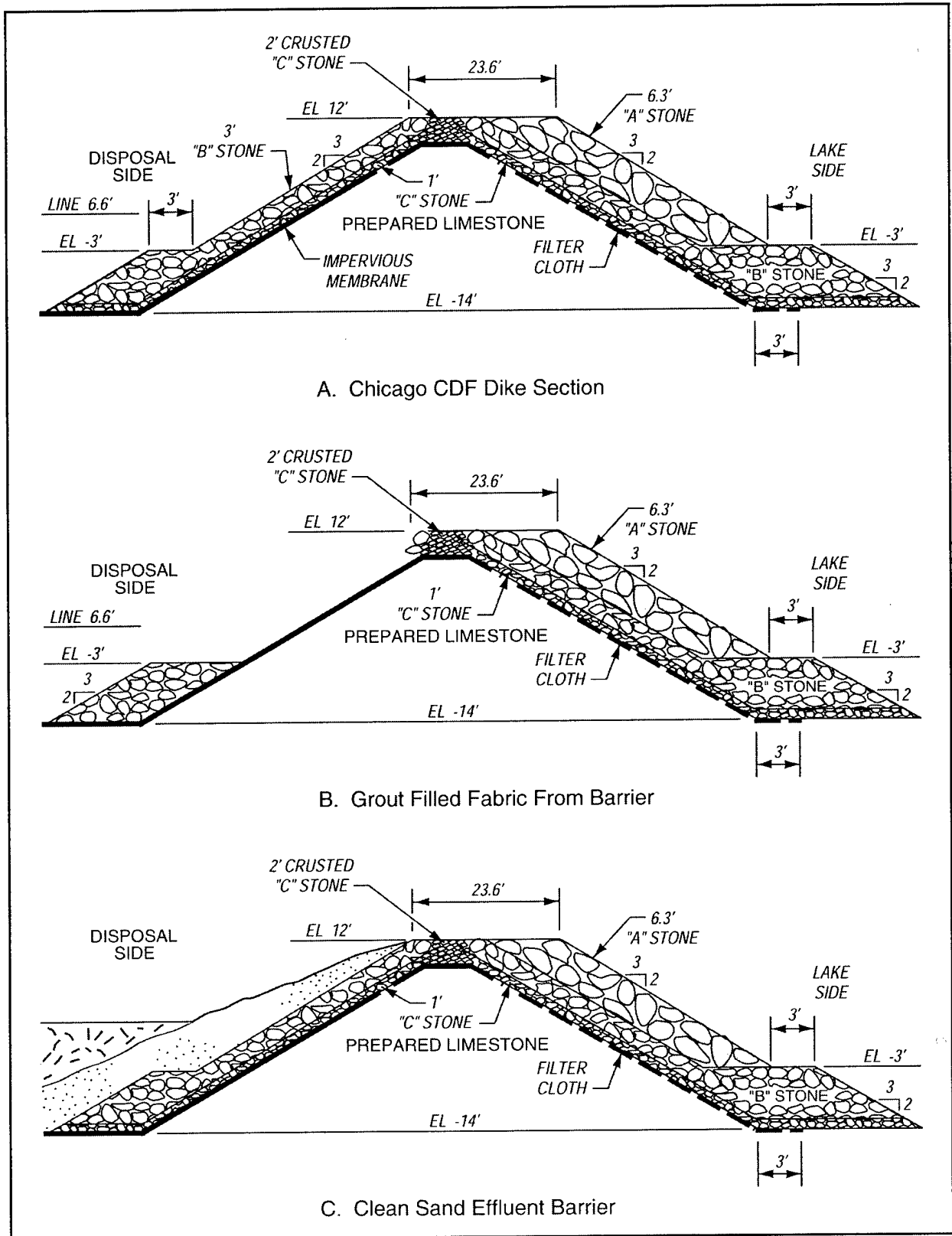

Figure 5. Chicago CDF dike cross-sections (to convert feet to meters, multiply by 0.3048)



Figure 6. Chicago CDF showing placement of geomembrane on inside dike face (photo courtesy Chicago District)

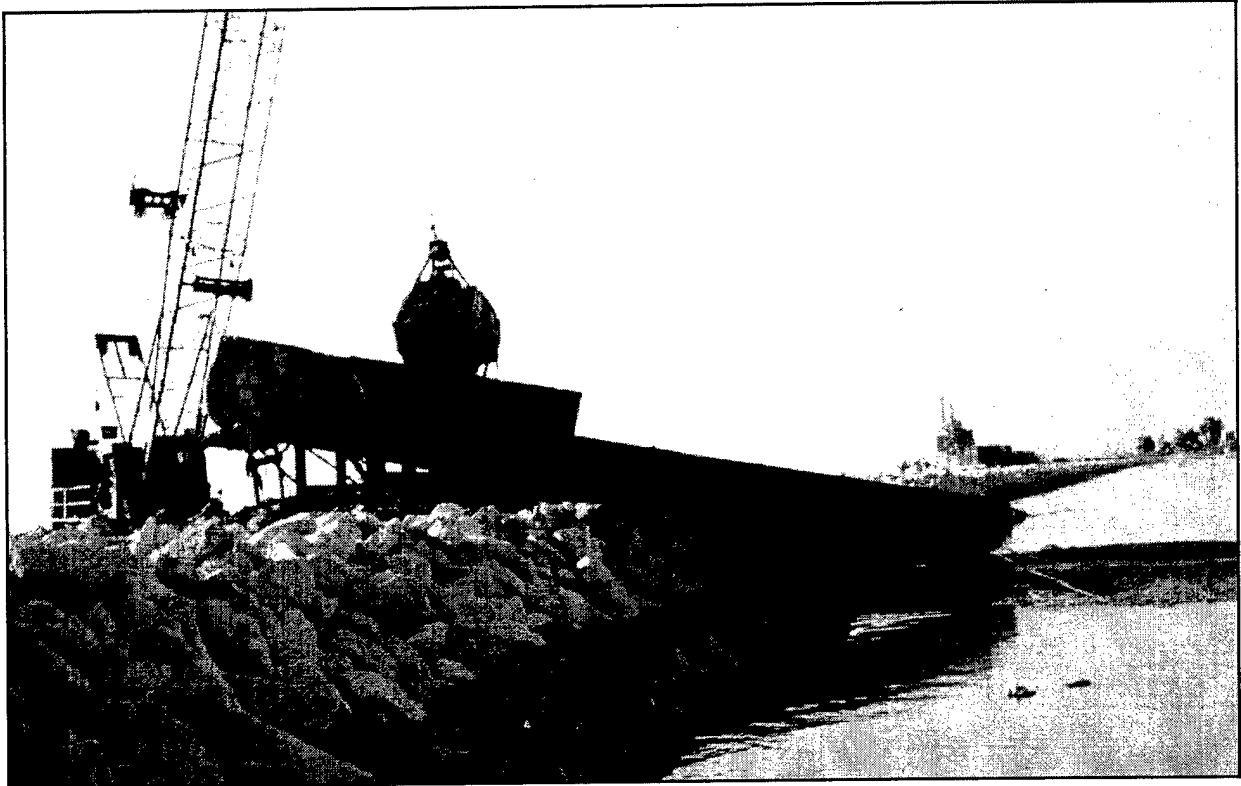

Figure 7. Chicago CDF showing placemnt of fine-grained dredged material blanket on inside dike face (photo courtesy Chicago District)

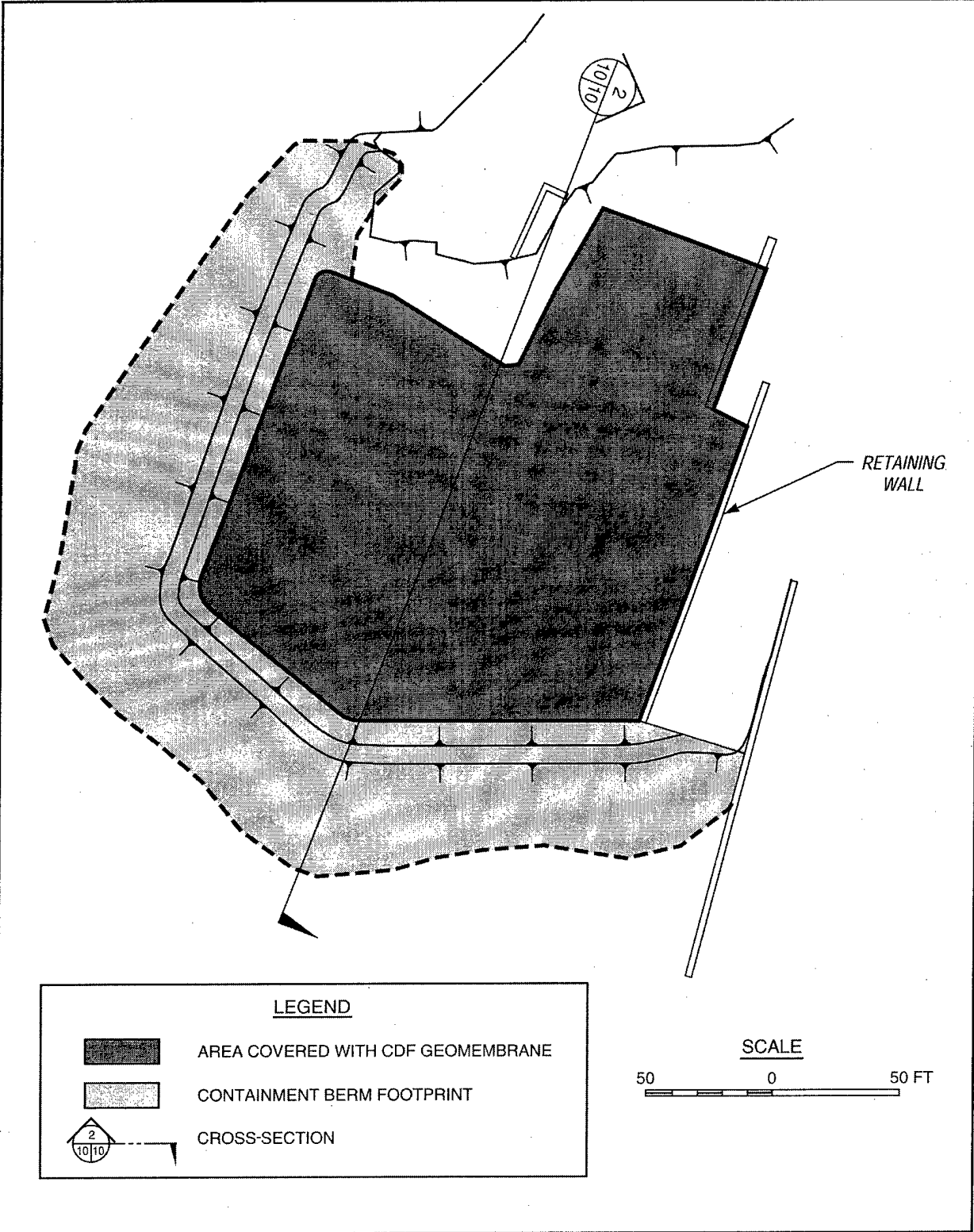

Figure 8. Eagle Harbor CDF plan view (to convert feet to meters, multiply by 0.3048)

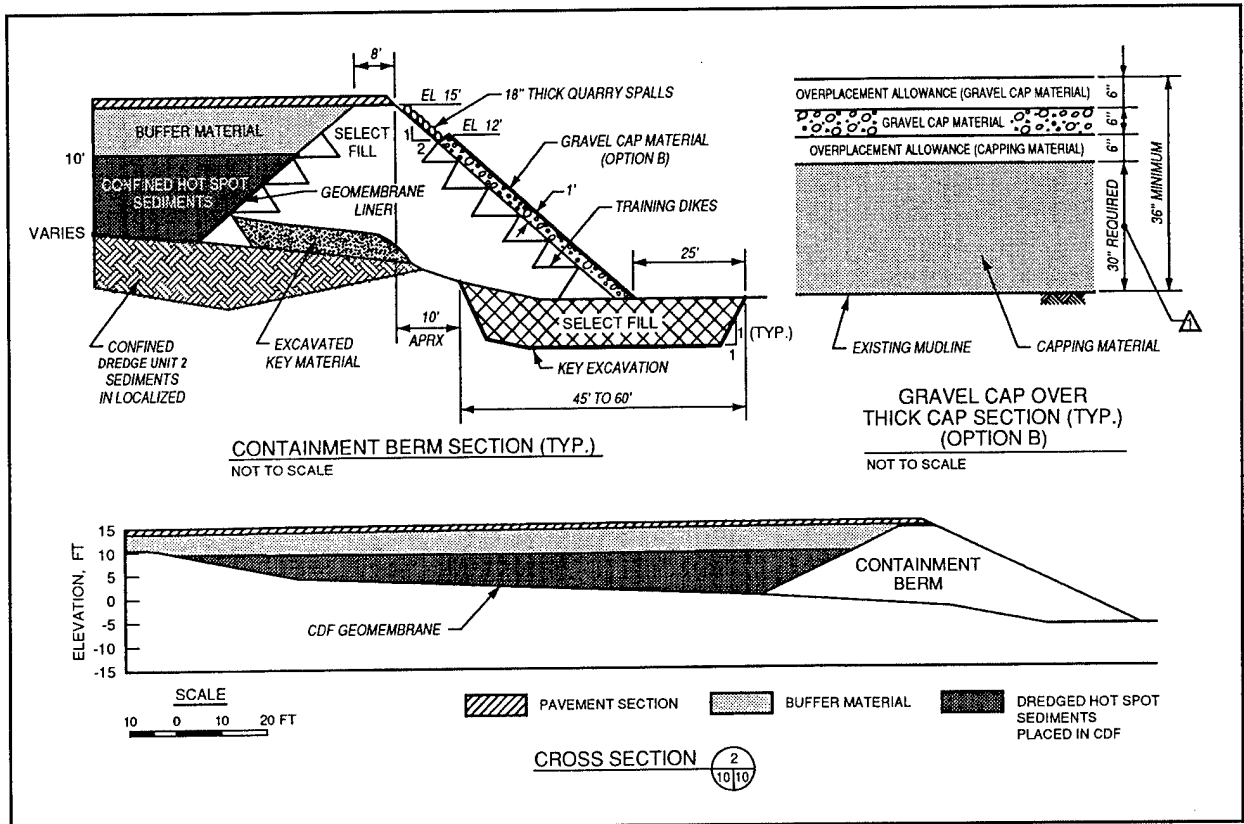

Figure 9. Eagle Harbor CDF cross-sectional view (to convert feet to meters, multiply by 0.3048; to convert inches to centimeters, multiply by 2.54)



Figure 10. Aerial photo of “dewatering fields” at Bremen, Germany (PIANC)

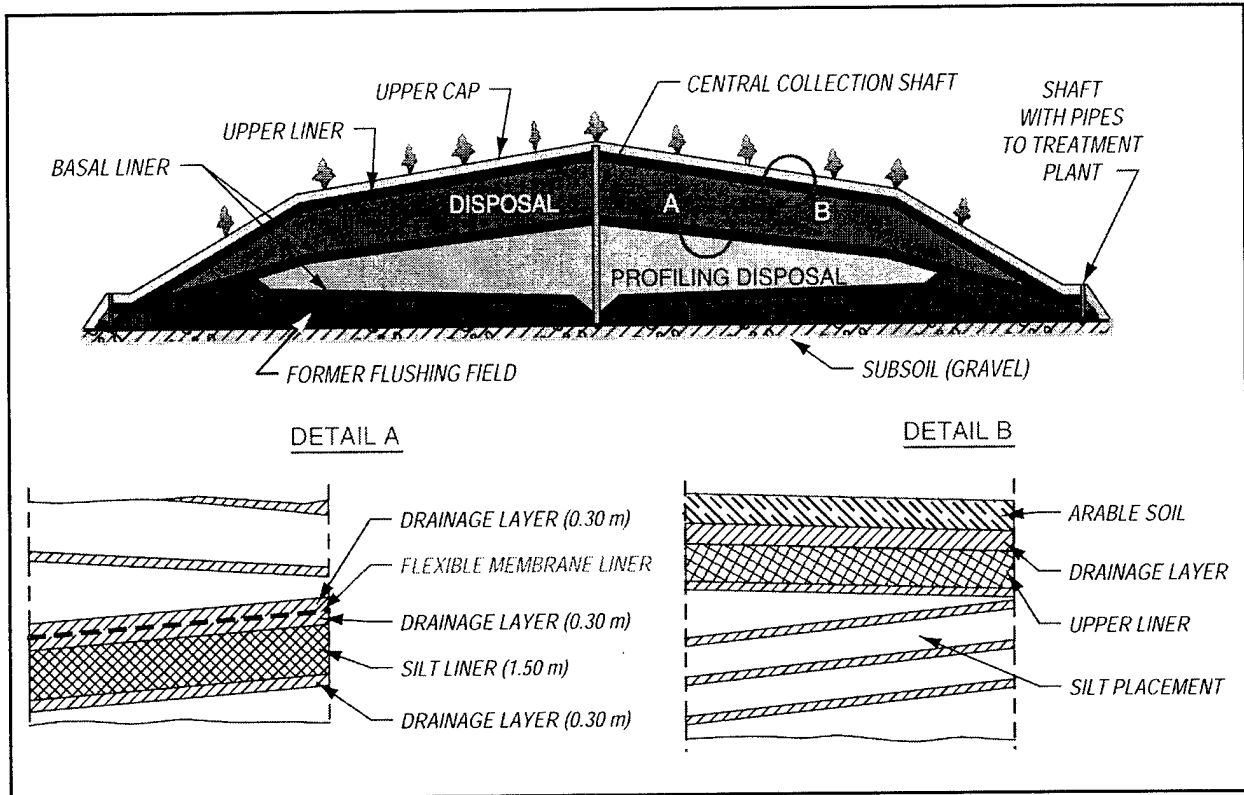

Figure 11. Cross-section of liner and cover design for silt mound at Hamburg, Germany

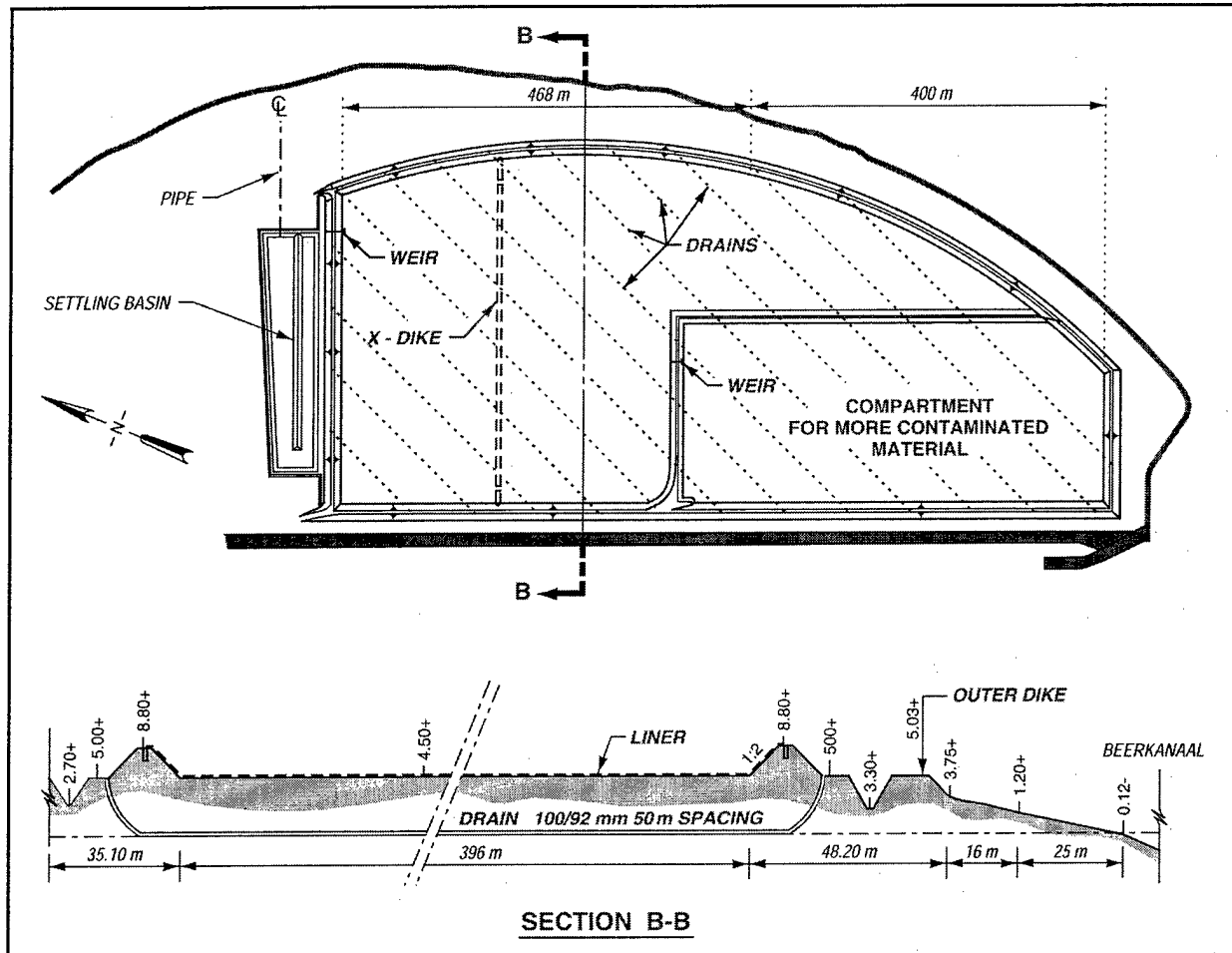

Figure 12. Parrot's Beak CDF, plan and typical cross-section

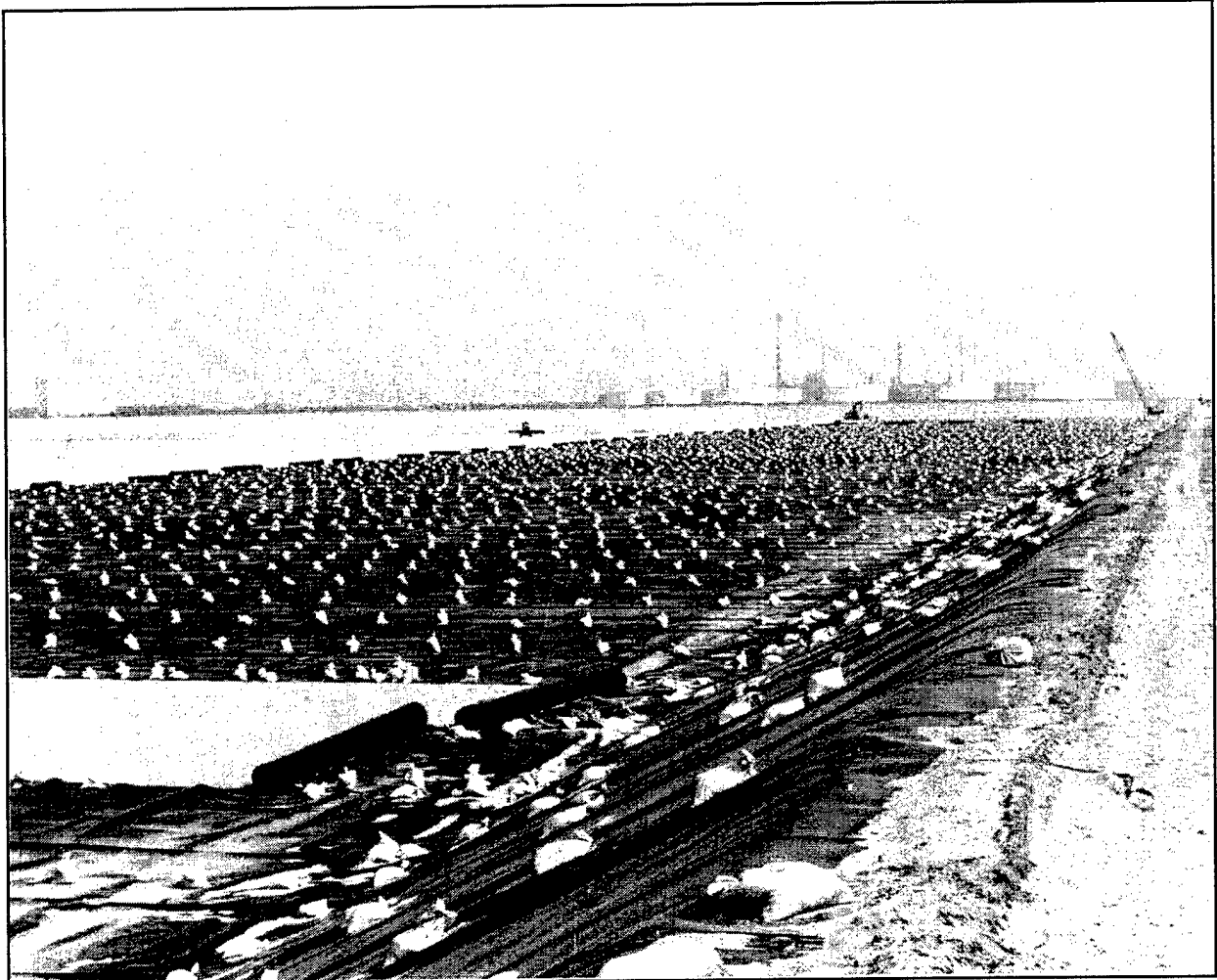

Figure 13. Liner construction at Parrot's Beak CDF, Rotterdam

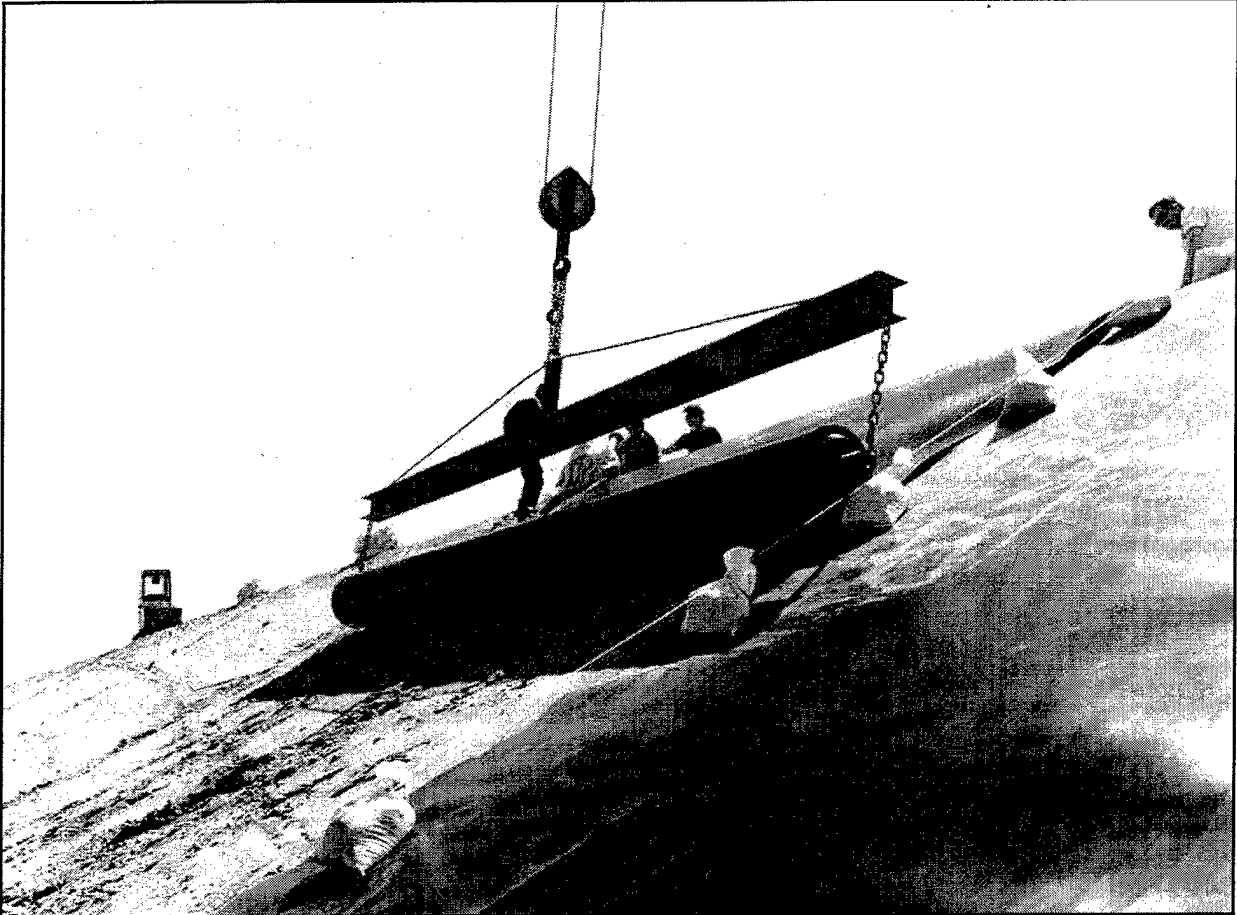

Figure 14. Liner placement on dike slope, Parrot's Beak CDF, Rotterdam

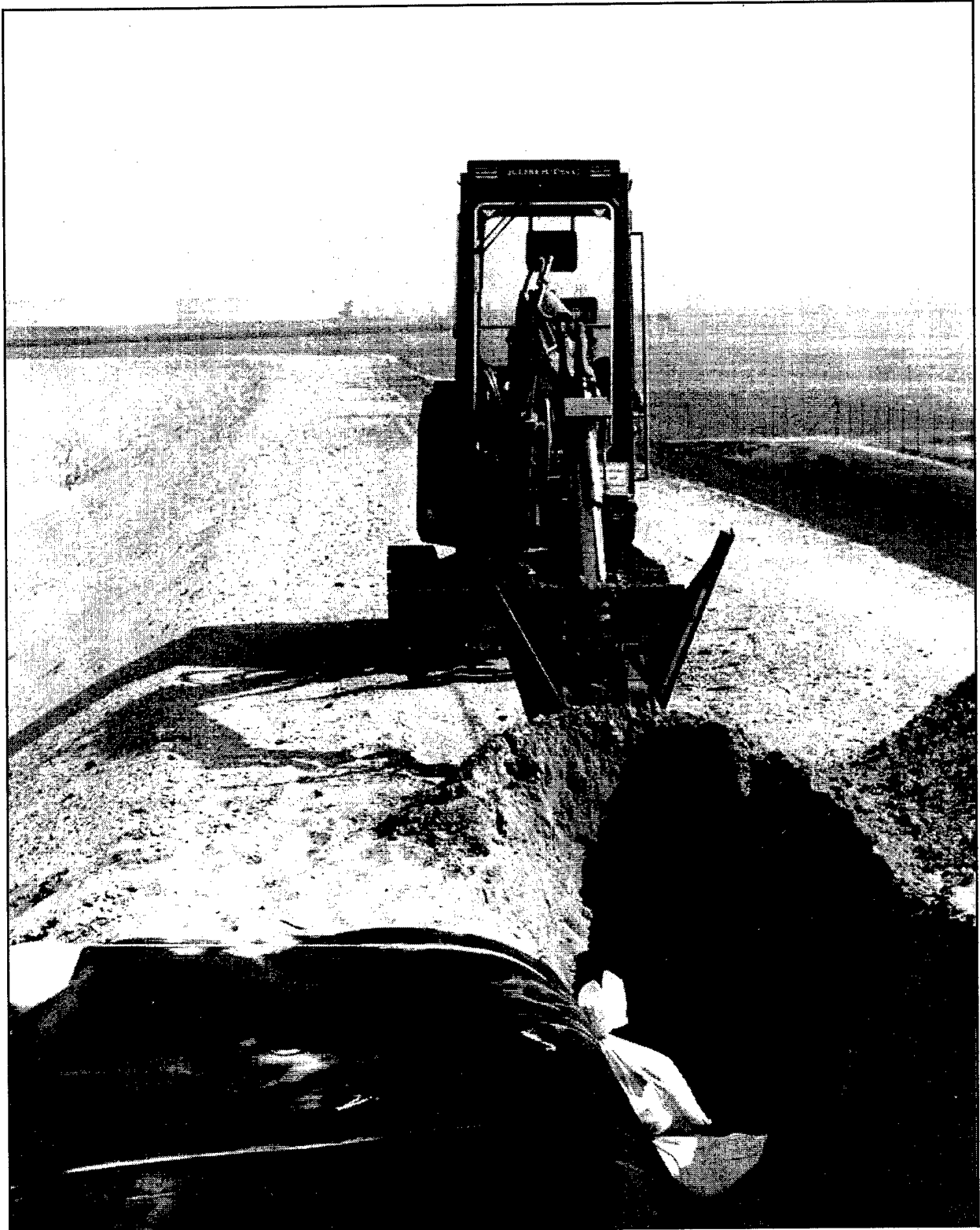

Figure 15. Liner anchor in dike crest, Parrot's Beak, Rotterdam

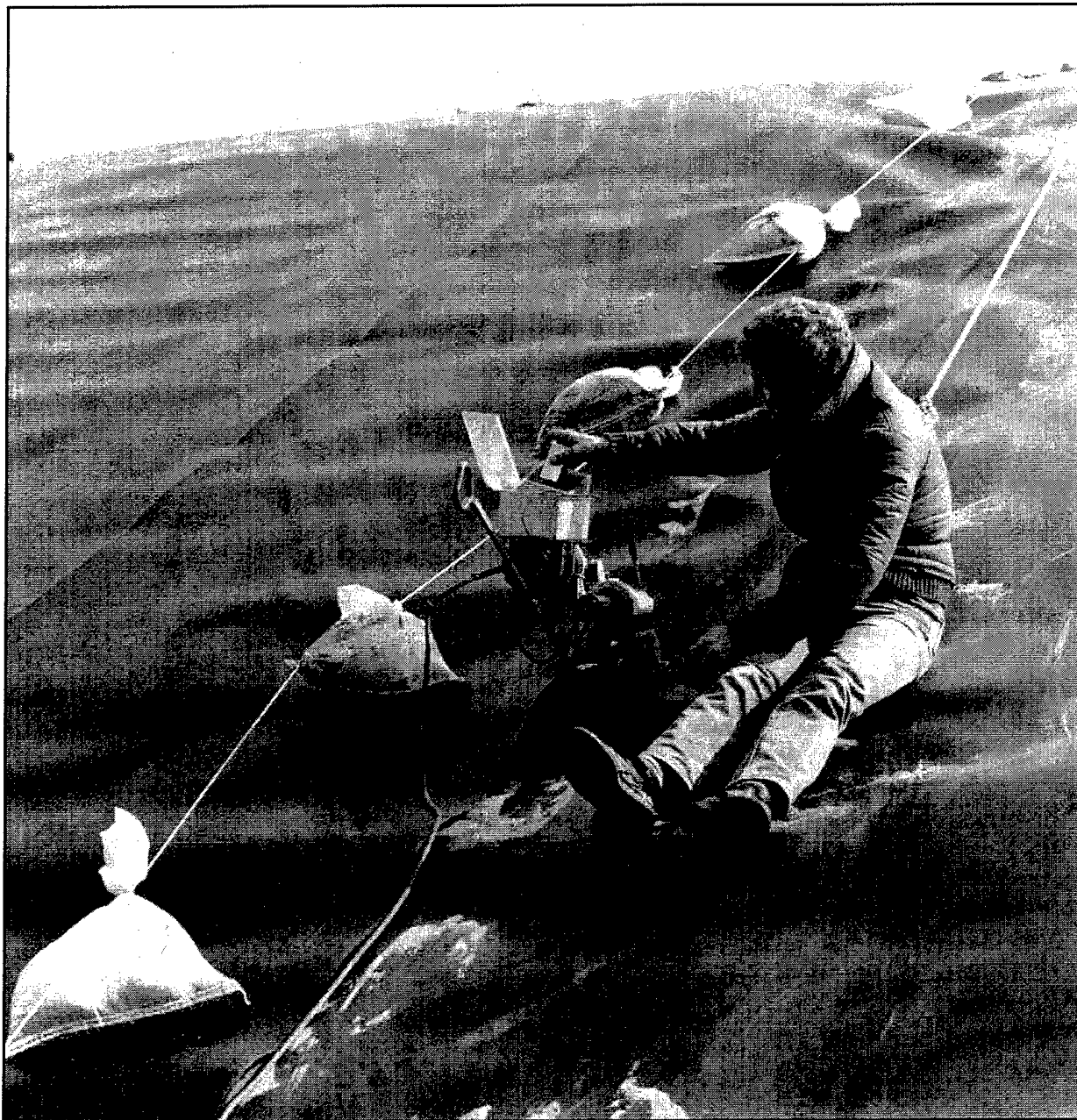

Figure 16. Heat welding liner, Parrot's Beak CDF, Rotterdam

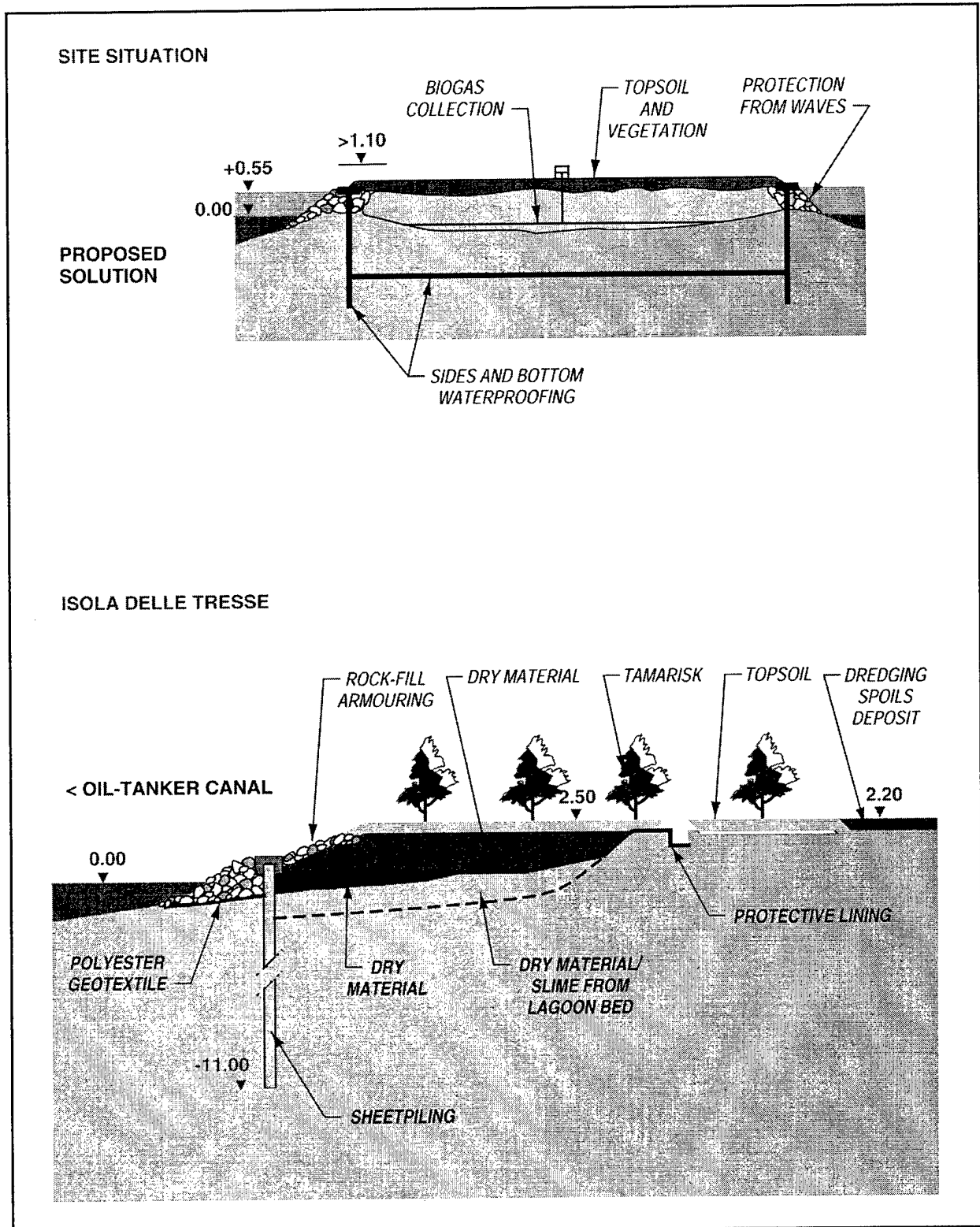

Figure 17. Tresse Island CDF, Venice, Italy, showing typical perimeter dike cross-section

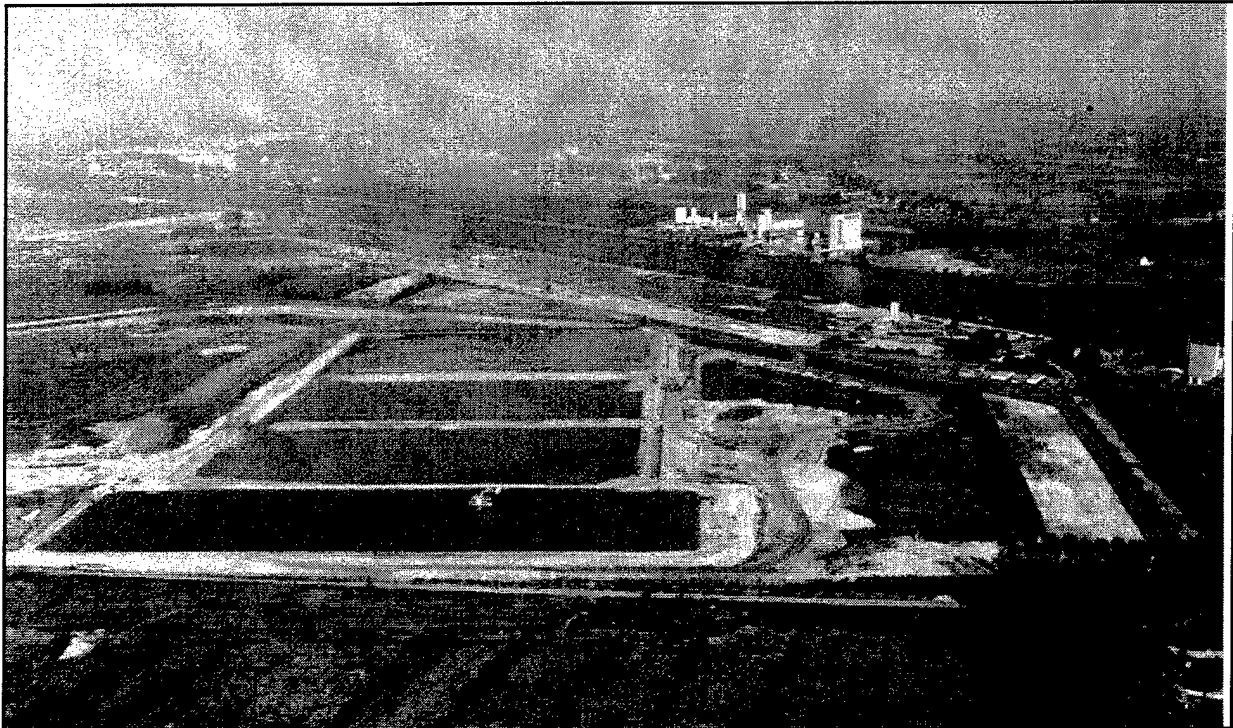

Figure 18. Geuzenhouck CDF, Ghent, Belgium, showing multiple compartments



Figure 19. Michigan City CDF, showing roller compaction of cap material (photo courtesy Detroit District)

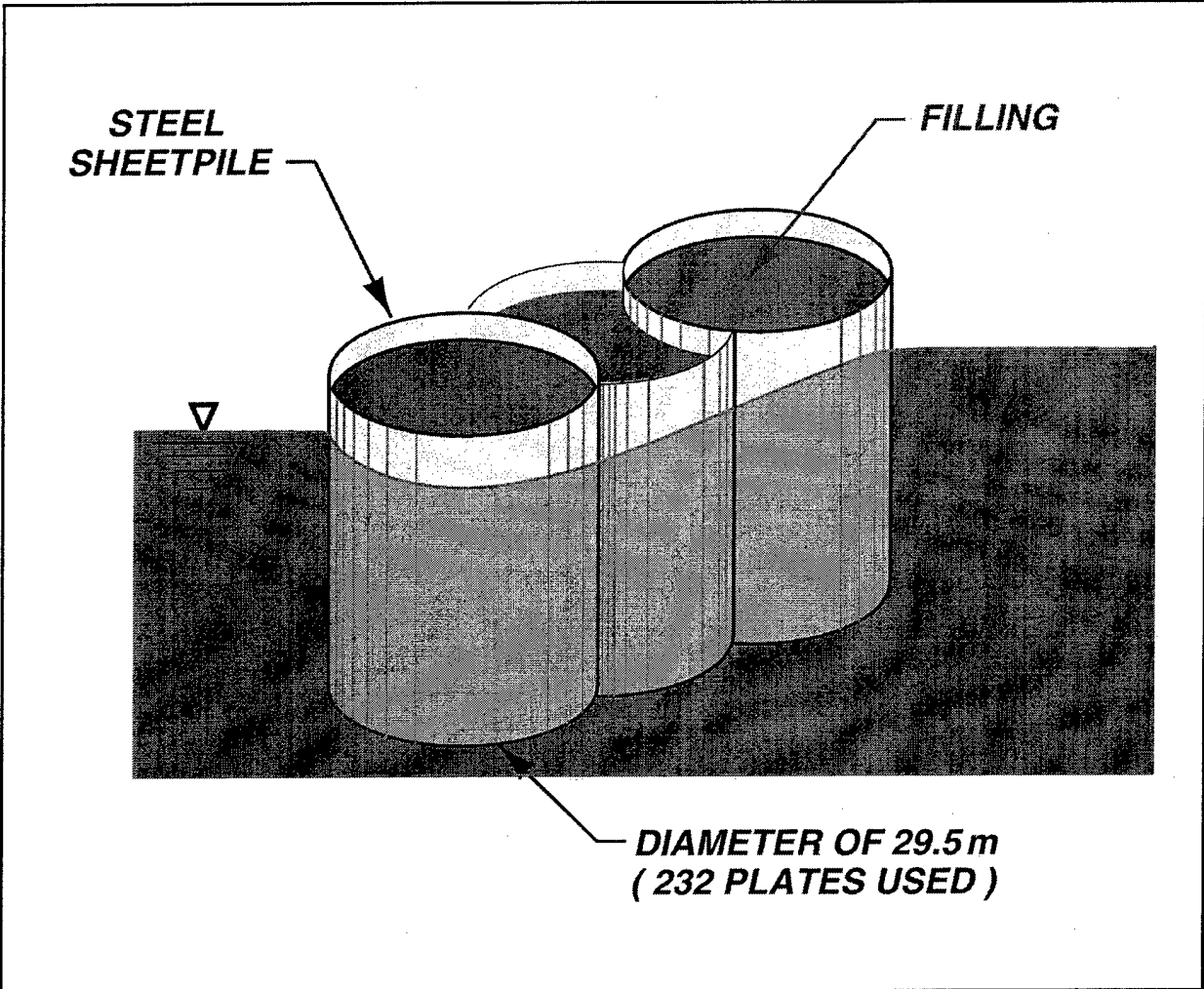

Figure 20. Illustration of cellular sheetpile section for Minamata Bay CDF

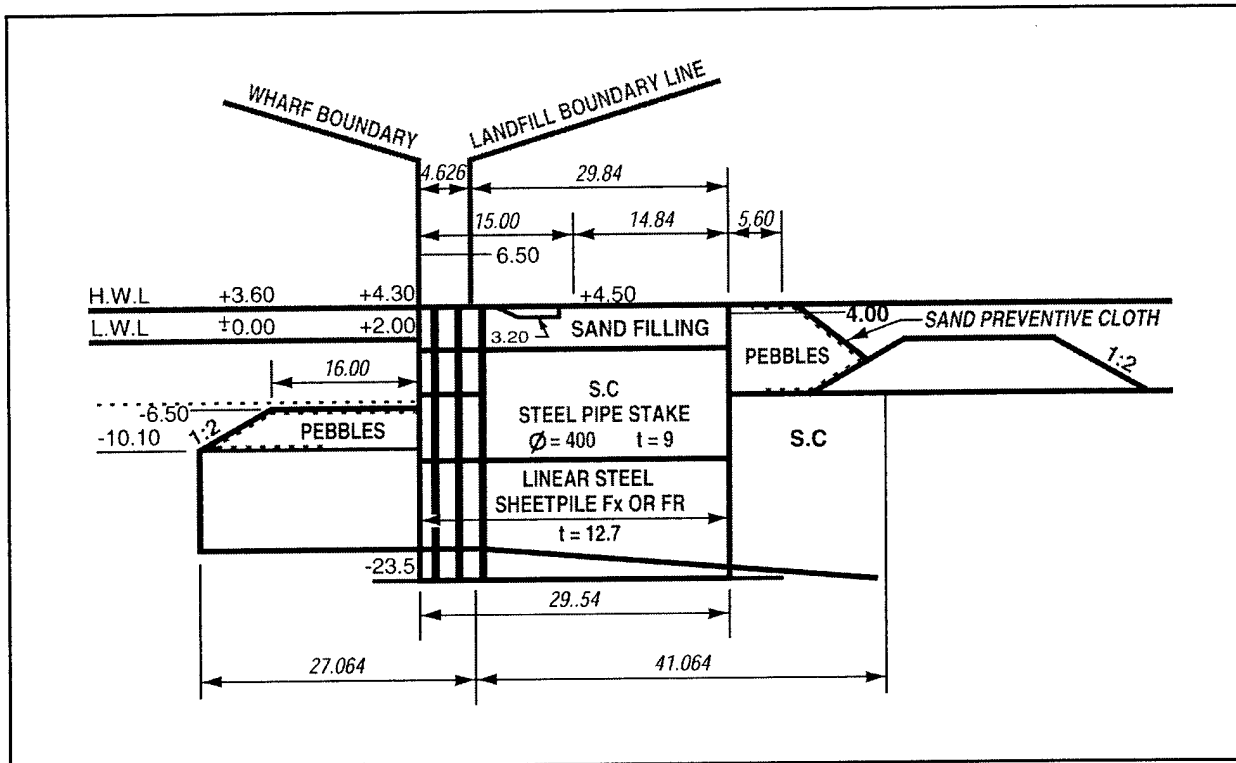

Figure 21. Minamata Bay CDF cellular sheetpile cross-section (units are in meters)



Figure 22. Photo showing hand placement of fiber cloth and rope net for surface cover construction, Minamata Bay CDF

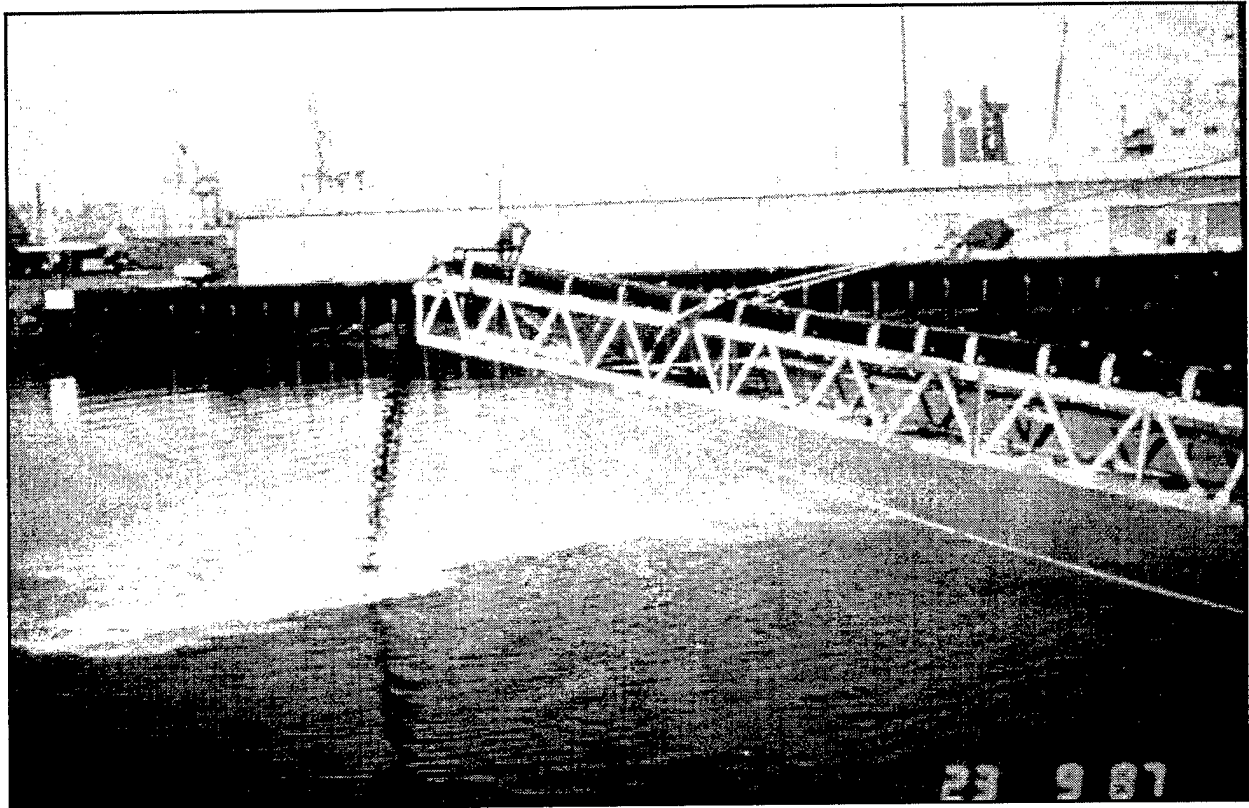

Figure 23. Photo showing surface cover under construction (conveyor placement) at Terminal 3 CDF, Seattle, WA



Figure 24. Photo showing surface cover under construction (conventional placement) at Terminal 3 CDF, Seattle, WA

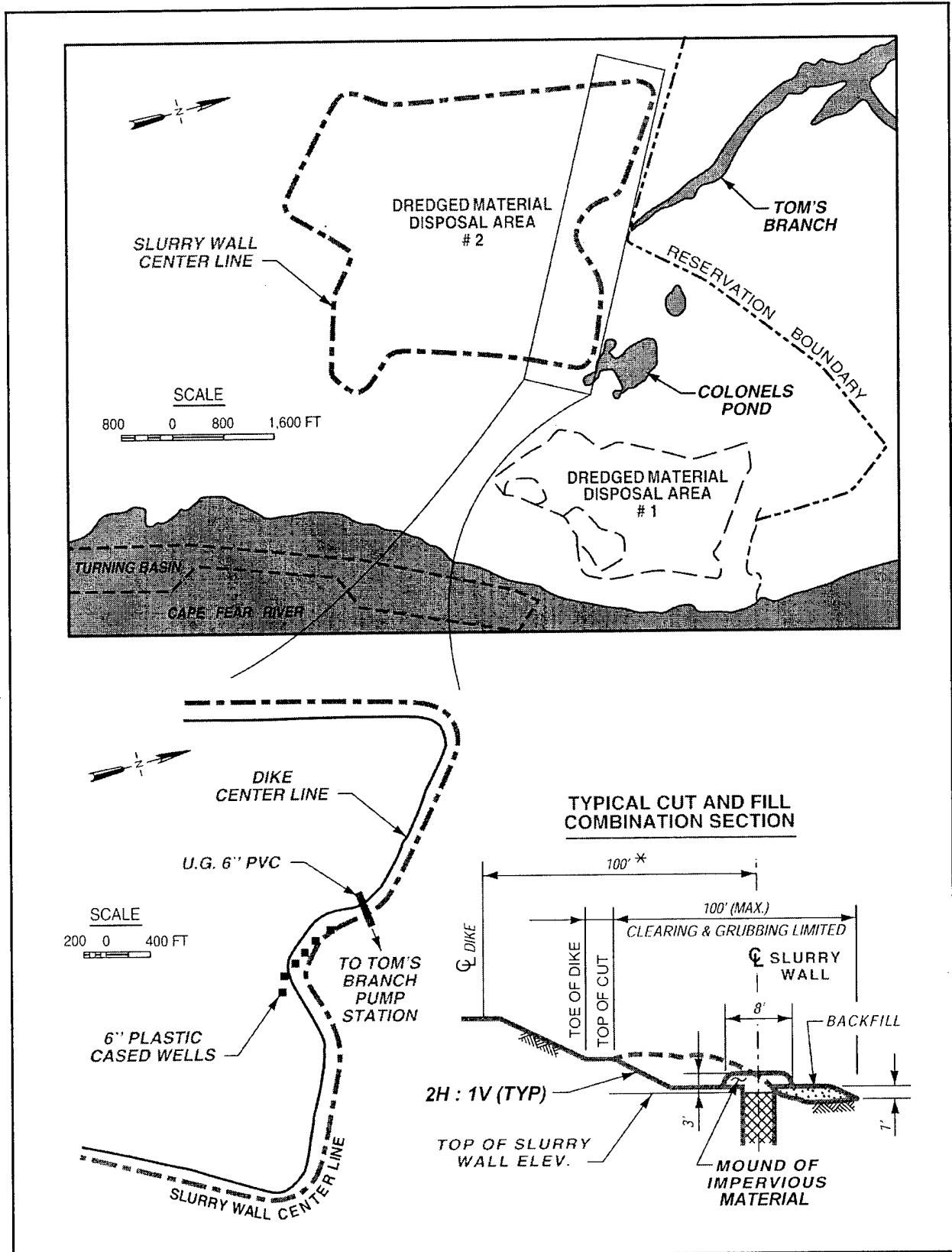

Figure 25. Plan and cross-sections of Sunny Point CDF showing slurry wall configuration

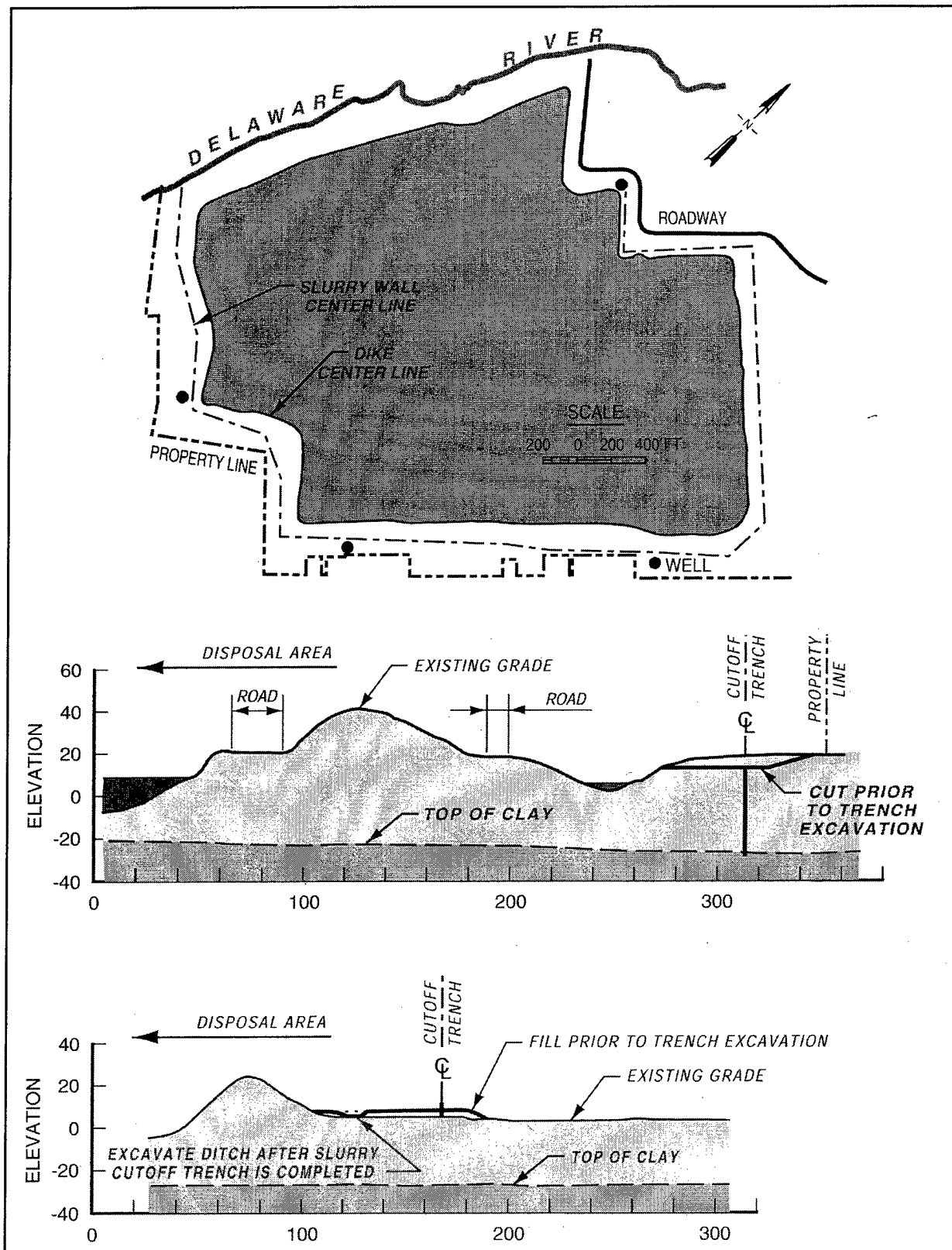

Figure 26. Plan and cross-sections of Penns Grove CDF, showing slurry wall configuration

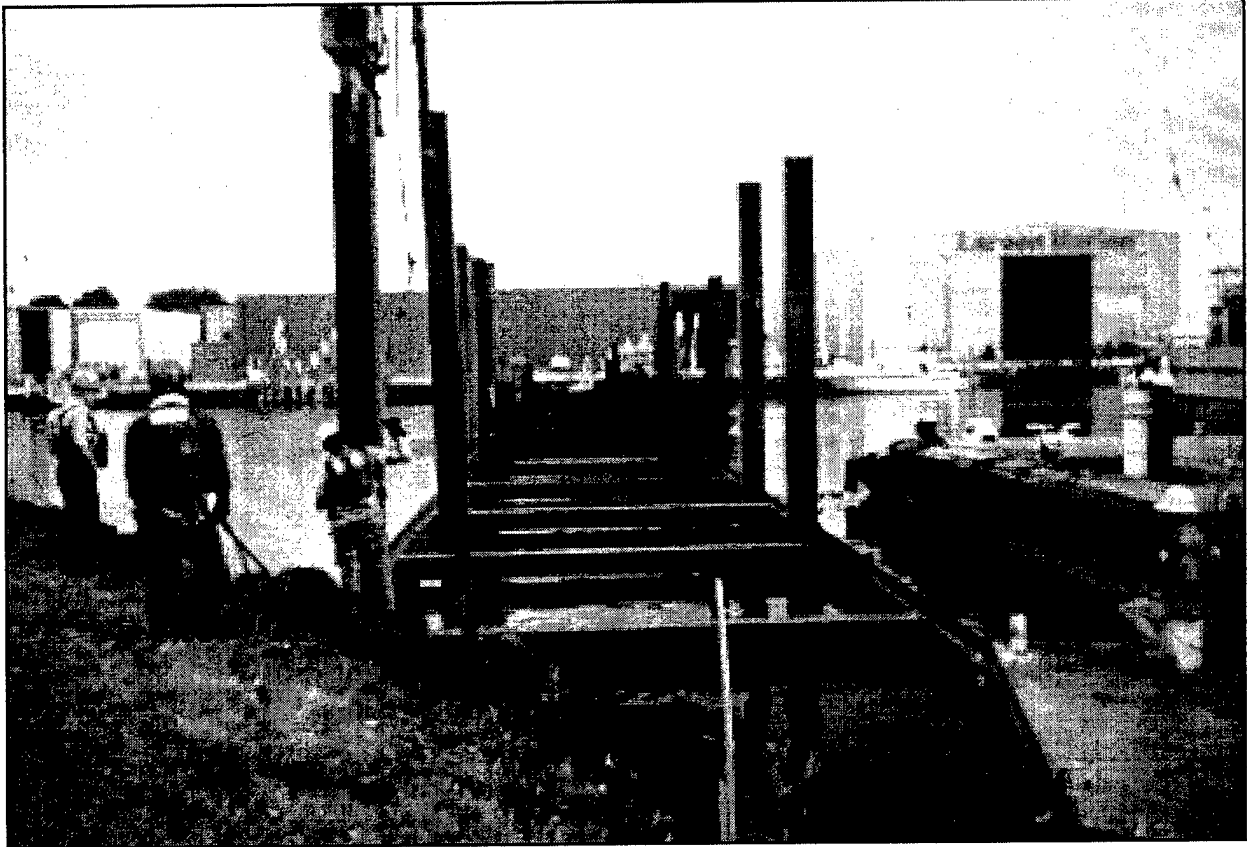

Figure 27. Double sheetpile wall under construction at Waukegan, IL, CDF