

The Report System

Papers available from ASM National and Regional Meetings are reproduced in the interest of disseminating information expeditiously to members of the Society and the metalworking industry.

(Note: ASM Transactions Papers are published in Transactions Quarterly)

EFFECT OF BETA WORKING ON 6Al-4V TITANIUM ALLOY

J. M. VAN ORDEN
L. L. SOFFA

AMPTIAC

Reproduced From
Best Available Copy

PRESENTED AT THE 1968 MATERIALS
ENGINEERING EXPOSITION & CONGRESS

DISTRIBUTION STATEMENT A 14-17 OCTOBER 1968
Approved for Public Release
Distribution Unlimited DETROIT, MICHIGAN

20000908 209

The Society is not responsible for statements or opinions advanced in papers or discussions at their meetings. For permission to reproduce this paper in its entirety, contact the ASM Publication Department and the authors.

Papers are abstracted in Metals Abstracts and the Engineering Index.



AMERICAN SOCIETY FOR METALS
METALS PARK, OHIO

**TECHNICAL
REPORT NO. D 8-24.3**

\$3 per copy
\$1.50 to ASM Members

EFFECT OF BETA WORKING
ON 6Al-4V TITANIUM ALLOY

J. M. Van Orden

L. L. Soffa

To be presented at the ASM Materials Engineering Congress
October 14 - 17, 1968, Detroit, Michigan

American Society for Metals
Copyright 1968

ABSTRACT

Effect of Beta Working on 6Al-4V Titanium Alloy

This paper describes the results of a structural and metallurgical study of a typical aircraft forging configuration. Specimen testing and testing of a full-size forging were conducted to determine the effects of mill forging procedures (both above and below the beta transus temperature), grain direction, section size, microstructure, and heat treatment condition on several properties. Properties investigated included smooth and notched tensile ultimate and yield strengths, per cent elongation, reduction of area, compression yield, shear and bearing strength, fracture toughness and smooth and notched constant amplitude fatigue strength. Smooth and notched tensile and fatigue tests also were conducted on electron beam welded specimens and, finally, a full-sized forging was fatigue tested under simulated service spectrum conditions.

The test results indicated that the several variables produced few significant differences in properties. Test specimens from material which had been forged above the beta transus showed slightly higher notched fatigue strength and fracture toughness, and electron beam welded specimens from material forged under both conditions showed higher fatigue strength than basis metal specimens. Other properties were comparable in general. The full-sized forging (processed above the beta transus temperature) showed spectrum fatigue properties equivalent to those exhibited by a conventionally forged, heat treated part, tested earlier in another study.

Macrostructure and microstructure studies indicated that the various section thicknesses had received varying amounts of working and varying rates of cooling during the forging process; however, the test results showed quite uniform properties in these sections.

The study indicated that properly controlled forging of this alloy above the beta transus temperature produced satisfactory properties which were comparable to the properties of material which had been forged under conventional conditions (primarily in the alpha-beta temperature range).

The authors are associated with the Lockheed-California Company, Burbank, California.

INTRODUCTION

Forging of titanium alloys above the beta transus temperature reportedly has two major advantages:

- a. Net forgings can be obtained so that less machining is necessary to reach finish dimensions.
- b. The forging process is cheaper because of better metal flow (lower energy requirements) at the higher forging temperatures.

→ Page 3

Early work on titanium alloy forgings indicated that finish forging temperatures should be kept below the beta transus temperature (in the alpha-beta range) because of detrimental effects on mechanical properties (ductility) associated with the acicular transformation product that occurs on cooling from the beta phase. This factor has prevented widespread use of beta forged products.

Other work (Ref. 1) showed that the alpha-beta alloys (such as Ti-6Al-4V) exhibited coarse beta grains with attendant low ductility and widely varying mechanical properties when forged above the beta transus temperature. The best combination of properties was stated to be achieved at forging temperatures approximately 100° below the beta transus in that work. Also, reworking of beta forged alloys below the beta transus temperature provided improvements in the ductility of alpha-beta alloys. As a result, conventionally forged parts are usually processed 50°-100°F below the beta transus temperature.

Because of the apparent advantages offered by beta processing, the producers have been working on forging procedures that would provide improvements in mechanical properties; and they have succeeded in producing material with improved ductility.

Initial beta forging development effort was conducted on engine components, air-frame components, and miscellaneous hardware. Designs forged and tested consisted of compressor wheels, turbine wheels, fan blades, engine mounts, flap carriages, tank tracks, etc.

Test results obtained in programs conducted on the components indicated slightly higher fracture toughness for beta forged material, and lower elongation values

Introduction Continued

in static mechanical property tests. Fatigue test results on the beta and alpha-beta forged material were similar based on very limited data.

Tests on beta processed forgings by other investigators (Ref. 2) indicate that the process can produce material with acceptable properties; however, large differences in mechanical properties have been reported by the different investigators. Since the total amount of testing of beta forgings has been small, additional information is needed to verify the mechanical properties, fracture toughness, and fatigue strength of test specimens; and to determine the static and fatigue properties of representative forged shapes.

This report describes new work conducted at the Lockheed-California Company Rye Canyon Research Laboratory during 1967. The work consisted of specimen testing and testing of a typical full-size forging, to verify properties and to determine uniformity of properties and microstructure in thick and thin sections at several locations within the forging.

to page 4

OBJECTIVES

The object of this investigation was to determine the engineering properties of annealed Ti-6Al-4V forgings which had been mill processed both above and below the beta transus temperature, and to compare these properties with conventionally processed (alpha-beta forged) heat treated forgings, tested in earlier Lockheed studies (Ref. 3).

→ pages

SUMMARY

Results of the specimen testing and testing of full-scale forgings processed above the beta transus temperature and in the alpha-beta temperature range, and testing of specimens and forgings reported in earlier work (Ref. 3) may be summarized as follows:

- (1) Room temperature smooth ^{T_i} tensile properties were slightly lower (approximately 10,000 psi) in the annealed beta and alpha-beta forged specimens compared to earlier results on alpha-beta heat treated material.
- (2) Room temperature ^{T_i} notched tensile properties were comparable for all of the forgings tested, and the notched tensile strength-ultimate tensile strength ratio was 1.53 for the current tests ($K_t = 3$) and 1.45 for the earlier heat treated forgings ($K_t = 3.9$).
- (3) Low temperature smooth tensile properties were slightly lower for the current tests (approximately 10,000 psi lower) than for the earlier tests.
- (4) Low temperature notched tensile strength was slightly higher for the current tests (approximately 12,000 psi) than for the earlier tests. The ratio was 1.55, versus 1.38 for the earlier tests.
- (5) ^{T_i} Compression yield strength was slightly lower (135-140 ksi) for the current tests than for the earlier test (148 ksi).
- (6) ^{T_i} Shear ultimate strength was somewhat lower (88 ksi) for the current tests than for the earlier test (102 ksi).
- (7) ^{T_i} Bearing yield and ultimate strengths were slightly lower for the current tests than for the previous tests.
- (8) ^{T_i} Fracture toughness test results were somewhat higher for the current tests (82-94 ksi√in.) than for the earlier tests (59 ksi√in.).

Summary Continued

- (9) Room temperature smooth tensile properties of ^{Ti} electron beam welded specimens were comparable to the basis metal properties (all specimens failed outside the weld zone) in all of the annealed forgings. Earlier tests did not include electron beam welded specimens.
- (10) Room temperature notched tensile properties of electron beam welded specimens were somewhat lower than the properties of the basis metal in the annealed forgings. Earlier tests did not include electron beam welded specimens. Stress relieving slightly lowered the notched tensile properties.
- (11) Room temperature constant amplitude fatigue test results were comparable for smooth specimens in both programs; however, notched fatigue test results were higher in the low cycle range for the current tests and comparable for both programs in the high cycle range. The earlier program material was in the solution treated and aged condition.
- (12) Room temperature constant amplitude fatigue test results for electron beam welded specimens showed a slightly lower fatigue strength for smooth specimens and a significantly higher fatigue strength for notched specimens compared with the basis metal properties. Stress relieving of the electron beam welded specimens lowered the fatigue strength of these specimens (only notched specimens were tested). Earlier tests did not include electron beam weldments.
- (13) Full-scale spectrum ^{Ti} fatigue test results for the beta forged (annealed) and earlier heat treated forging were comparable.
- (14) Macro-and microstructure analyses showed marked variations in the apparent amount of working (grain flow patterns) in various sections of the forgings examined.
- (15) ^{Ti} Microstructure analyses showed marked variations in the microstructures in the thick and thin sections of the forgings with the thicker sections showing coarser platelet structure and less working.

Summary Continued

(16) The absence of discrete grain boundaries in the microstructure did not permit meaningful grain size measurements in the beta forged material.

→ 1208

TEST PROCEDURE

I. Test Specimen Preparation and Testing:

A typical rough forging shape is shown in Figure 1. Forgings, both beta forged and alpha-beta forged, were machined into test coupons. Test coupons were machined from the center section, mid-radius, web, cap or flange, and flange transition areas along the length of the forging in the three grain directions.

The various test specimens are shown in Figures 2 through 5. All of these are standard Lockheed test specimens with the exception of those shown in Figure 3. These smooth and notched tensile specimens were shortened slightly because of material limitations in the electron beam welded blocks. Electron beam welded fatigue test specimens also were slightly shorter than standard lengths for the same reason. The standard length fatigue specimens are shown in Figure 5.

The locations of typical test specimens within the forgings are shown in Figures 6, 7, and 8.

Specimen testing was conducted at room temperature and at -110°F in accordance with standard test procedures. Smooth and notched tensile, compression, shear, bearing, fracture toughness, and constant amplitude fatigue tests were conducted on basis metal specimens; and smooth and notched tensile and fatigue tests were conducted on specimens machined from electron beam welded blocks.

Stress levels used in the fatigue testing of the forging specimens in this study were based on current available data and were selected to produce failure primarily in the range of 10^4 to 10^7 cycles.

II. Full Scale Test Specimen Preparation and Testing:

Numerical tape control machining was used, and a typical machined part is shown in Figure 9. The forging was originally selected in previous programs (Ref. 3) to represent a typical airplane forging design. This part is a fuselage ring fitting which joins the forward beam of the vertical stabilizer to the aft fuselage. The part includes local effects of skin attachment holes, fin to spar attachment lugs, and curved flanges following fuselage contour.

Test Procedure Continued

II. Full Scale Test Specimen Preparation and Testing Continued:

The forging was installed in a test fixture that was used in previous programs (Ref. 3) to fatigue test similar forgings of various titanium alloys.

The test loading spectrum was the same one used to test similar forgings in the previous programs. This spectrum was based on the lateral gust spectrum originally specified for application to the vertical fin of a typical aircraft, except that the severity of the spectrum was increased to insure failure in a reasonable test time. The fatigue loadings consisted of a varying side load (P_Y) and a mean vertical load (P_Z). Repetitive applications of the unit spectrum were applied one at a time until failure occurred. The mean vertical load (P_Z) and counterbalance of the loading fixture were applied with dead weight. The varying side loads (P_Y) were applied with a single hydraulic jack at a point 30 inches above the top deck of the forging. The loads were sensed by a strain gage type transducer mounted in series with the hydraulic jack and were controlled by an Electronic circuit.

The vertical mean load (P_Z) and the M_X moment were reacted through flexure pivots and the P_Y shear loads were reacted alternately by one of two tension straps. Figures 10 and 11 show the fatigue test setup.

III. Metallurgical Analysis

Full-sized cross sections were prepared from several of the forgings, finish machined and etched to show grain flow patterns, and comparative amount of working.

Additionally, selected sections were cut from heavy center sections and thinner end sections in both rough and machined forgings, ground, polished, and etched to compare microstructures, grain size, platelet size, etc.

end

TEST RESULTS

I. Specimen Tests:

A. Room Temperature Tensile Test Results - Smooth Specimens:

1. Forging No. 1 (beta forged):

Ultimate tensile strength ranged from 138,300 to 147,700 psi with the specimens from the heavy center section showing generally lower values than the transition and web areas of the forging.

Tensile yield strength ranged from 125,800 to 139,100 psi with the center exhibiting the lowest properties and the transition and web portion showing the highest strength.

Per cent elongation ranged from 11.3% in the center to 14% for the web portion of the forging. This forging exhibited fairly uniform elongation in all areas except for the web where elongation was two per cent higher than in the other areas tested.

Reduction of area ranged from 24.3% in the center section of the forging to 38.6% in the web portion of the component.

In general, the tensile properties in a given section of the forgings, i.e., center, web, etc., were quite uniform.

These data are given in Table 1.

Forging No. 2 (beta forged):

Ultimate tensile strength ranged from 138,500 to 151,200 psi with specimens from the flange area exhibiting the highest strength and the test specimens from the center showing the lowest strength levels.

Tensile yield strength ranged from 125,000 to 144,500 psi. The flange portion of the forging showed the highest yield strength, and the center and surface areas exhibited the lowest yield strength.

Test Results Continued

I. Specimen Tests Continued:

A. Room Temperature Tensile Test Results - Smooth Specimens Continued:

1. Forging No. 2 (beta Forged) Continued:

Per cent elongation ranged from 11% in the center to 15% in the web portion of the forging.

The web, flange, and transition areas of the forging exhibited fairly uniform elongation values, whereas, the center and surface areas were generally lower.

Reduction of area ranged from 38% in the transition area to a low of 23.6% in the same area.

The web and flange area exhibited fairly uniform reduction of area, whereas, the transition area showed a wide spread in reduction of area.

The data for this forging are given in Table 2.

2. Forging (alpha-beta forged):

Ultimate tensile strength ranged from 136,100 psi to 149,600 psi with specimens from the center exhibiting the lowest strength and the web portion of the forging showing the highest strength.

Tensile yield strength ranged from 126,800 psi to 143,300 psi with specimens from the center of the forging exhibiting the lowest strength and the specimens from the web showing the highest strength.

Per cent elongation ranged from 14% to 16% with the transition area exhibiting the highest elongation and the center section the lowest elongation.

Reduction of area ranged for 32% to 45% with the transition area exhibiting the highest reduction of area and the center section the lowest reduction of area.

The data for this forging are given in Table 3.

Test Results Continued

I. Specimen Tests Continued:

B. Room Temperature Tensile Test Results - Notched Specimens ($K_t = 3$):

1. Forging No. 1 (beta forged):

Notched tensile strength was 211,000 psi for all grain directions taken from the center of the forging.

The notched tensile strength-ultimate tensile strength ratio was 1.51 to 1.52 for all specimens tested.

These data are given in Table 1.

Forging No. 2 (beta forged):

Notched tensile strength ranged from 207,600 psi to 230,000 psi. Surface specimens exhibited the lowest values and the web area test specimens showed the highest strength levels.

The notched tensile strength-ultimate tensile strength ratio ranged from 1.45 in the flange transition area to 1.57 in the web transition area of the forging.

These data are given in Table 2.

2. Forging (alpha-beta forged):

The notched tensile strength for all specimens ranged from 209,300 psi to 213,000 psi, indicating that this property was uniform for the center of the forging.

The notched tensile strength-ultimate tensile strength ratio ranged from 1.51 to 1.54 indicating good uniformity of properties for center section material.

These data are given in Table 3.

C. Low Temperature (-110°F) Test Results - Smooth Specimens:

1. Forgings No. 1 and 2 (beta forged):

Ultimate tensile strength ranged from 159,600 psi to 174,000 psi,

Test Results Continued

I. Specimen Tests Continued:

C. Low Temperature (-110°F) Test Results - Smooth Specimens Continued:

1. Forgings (beta forged) Continued:

with center section specimens exhibiting the lowest strength and flange area specimens yielding the highest strength.

Tensile yield strength ranged from 144,600 psi to 167,000 psi, with center section specimens yielding the lowest strength and flange area specimens exhibiting the highest strength levels.

Per cent elongation ranged from 9.6% to 13% with center section having the lowest elongation and the flange area showing the highest elongation.

Reduction of area ranged from 23% to 29%. The center section showed the lowest value and the flange area exhibited the highest reduction of area.

2. Forging (alpha-beta forged):

Ultimate tensile strength for unnotched alpha-beta forged material in the short transverse grain direction averaged 169,600 psi for center section material.

Tensile yield strength in this section averaged 163,000 psi.

Per cent elongation for three specimens averaged 13%. Reduction of area was found to be 33.3%.

These data are given in Tables 1, 2, and 3.

D. Low Temperature (-110°F) Tensile Test Results - Notched Specimens:

1. Forgings No. 1 and 2 (beta forged):

Notched tensile strength ranged for 252,000 psi to 267,000 psi. The center section exhibited the lowest strength and the flange portion the highest strength.

The ratio of notched tensile strength to ultimate tensile strength was 1.53-1.55.

Test Results Continued

I. Specimen Tests Continued:

D. Low Temperature (-110°F) Tensile Test Results - Notched Specimens Continued:

2. Forging (alpha-beta forged):

The notched tensile strength was found to be 254,000 psi. The ratio of notched tensile strength to ultimate tensile strength was found to be 1.50.

These data are given in Tables 1, 2, and 3.

E. Room Temperature Compression Test Results:

1. Forgings (beta forged and alpha-beta forged):

The data indicate slightly higher compression yield strength for the alpha-beta forging in the longitudinal grain direction (approximately 7,000 psi higher) but comparable properties in the transverse grain direction for both forgings. Yield strengths ranged from a low value of 134,800 psi in the beta forging to a high value of 142,300 psi in the alpha-beta forging.

These data are given in Tables 1 and 3.

F. Room Temperature Shear Test Results:

1. Forging No. 2 (beta forged):

Room temperature shear tests were conducted on only one of the beta-worked forgings in the longitudinal grain direction. The ultimate shear strength was 88,400 psi.

These data are given in Table 2.

G. Room Temperature Bearing Test Results:

1. Forging No. 2 (beta forged):

Bearing tests were conducted on longitudinal test specimens machined from the heavy center section of one of the beta-forged forgings. With an edge distance of 2, the bearing yield strength was 230,000 psi and the bearing ultimate strength averaged 288,000 psi.

These data are given in Table 2.

Test Results Continued

I. Specimen Tests Continued:

H. Fracture Toughness Test Results:

1. Forgings (beta forged and alpha-beta forged):

Fracture toughness test specimens were prepared in the short transverse grain direction from the heavy center portion of the forgings and tested at room temperature and at -110°F .

The data indicated somewhat higher K_{Ic} values for the beta forged specimens both at room temperature and at -110°F . At room temperature, the K_{Ic} values averaged $94 \text{ ksi}\sqrt{\text{in}}$. for the beta forging and averaged $82 \text{ ksi}\sqrt{\text{in}}$. for alpha-beta forging. Lowering the test temperature to -110°F did not affect the K_{Ic} values significantly for either forging.

These data are given in Tables 1 and 3.

I. Room Temperature Smooth Tensile Tests - EB Welded Specimens:

1. Forgings (beta forged and alpha-beta forged):

Smooth tensile specimens were prepared from electron beam welded blocks taken from the heavy center sections of the forgings in the longitudinal grain direction.

The tensile strength ranged from 136,000 psi to 140,000 psi for all three forgings and the yield strength, per cent elongation and per cent reduction of area were similar to the properties of the basis metal. This was expected since these specimens all failed in the basis metal away from the weld metal zone.

These data are given in Table 4.

J. Room Temperature Notched Tensile Tests - EB Welded Specimens:

1. Forgings (beta forged and alpha-beta forged):

Notched tensile specimens ($K_t = 3$) were prepared from electron beam welded blocks taken from the heavy center sections of the forgings in the longitudinal grain direction. The notched tensile strength ranged from 186,000 psi to 196,000 psi for the beta forging specimens and from 189,000 psi to 201,000 psi for the alpha-beta forging specimens.

Test Results Continued

I. Specimen Tests Continued:

J. Room Temperature Notched Tensile Tests - EB Welded Specimens Continued:

1. Forgings (beta forged and alpha-beta forged) Continued:

The data indicate a somewhat lower notched tensile strength for the electron beam welded specimens than for the notched basis metal specimens (186,000 to 201,000 psi for the electron beam welded specimens versus 207,000 to 217,000 psi for the basis metal data).

The notched-to-unnotched tensile strength ratio was computed on the basis of basis metal properties and it ranged from 1.36 to 1.41.

Some of these test specimens had been stress relieved (annealed) at 1300°F for 2 hours in vacuum and air cooled. This treatment produced a slight decrease in the notched tensile strength (approximately 5,000-10,000 psi decrease).

These data are given in Tables 1, 2, and 3.

K. Room Temperature Constant Amplitude Fatigue Test Results:

1. Forgings (beta forged and alpha-beta forged):

Room temperature constant amplitude fatigue tests were conducted on specimens machined from three forgings. A range ratio of + 0.1 was used in all tests and both smooth and notched specimens ($K_t = 3$) were tested. The test specimens were machined in the longitudinal grain direction in the central heavy portion of the three forgings, and additional short transverse test specimens were prepared from one beta forging.

The fatigue curves (Figure 12) indicate an approximate fatigue strength of 66,000 psi at 10^7 cycles for smooth longitudinal specimens (all forgings), and an approximate fatigue strength of 26,000 psi at 10^7 cycles for notched longitudinal specimens ($K_t = 3$) for the two beta forgings (20,000 psi for the alpha-beta forging). Short transverse specimens (from one beta forging only) showed a slightly lower approximate fatigue strength (23,000 psi) at 10^7 cycles. The data indicates slightly lower notched fatigue properties for the alpha-beta forging.

Test Results Continued

I. Specimen Tests Continued:

L. Room Temperature Constant Amplitude Fatigue Test Results - EB Welded Specimens:

1. Forgings (beta forged and alpha-beta forged):

Smooth and notched constant amplitude fatigue test specimens were prepared from electron beam welded blocks taken from the heavy center sections of the forgings in the longitudinal grain direction. A range ratio of + 0.1 was used in all tests.

The fatigue data (Figures 13, 14, and 15) indicate that smooth specimen fatigue strength was lower for these specimens than for basis metal specimens (upper curves and data points in Figures 13 and 15). Close examination of the specimens disclosed that failure had occurred near or in the heat-affected zone adjacent to the weld metal in all specimens; therefore, the data do not reflect fatigue strength of the weld metal itself, rather, the data reflect the effect of the weldment on adjacent metal, or heat-affected metal.

Notched specimen fatigue strength was significantly higher in these specimens than in the basis metal specimens. The fatigue strength was 65,000 psi for the beta forged material and 55,000 psi for the alpha-beta forged material at 10^5 cycles, and 44,000 psi for both types of forgings at 10^7 cycles.

Corresponding fatigue strength values for the basis metal were 50,000 psi and 45,000 psi at 10^5 cycles, and 26,000 psi and 20,000 psi at 10^7 cycles.

Stress relieving of notched specimens at 1300°F for 2 hours lowered the fatigue strength of both beta forged and alpha-beta forged material. These data points are shown in Figures 13, 14, and 15 (cross-hatched points).

II. Full-Scale Forging Tests

A. Fatigue Test Results:

1. Forging (beta forged):

The beta forging sustained a total of 168, 284 cycles of the test

Test Results Continued

II. Full Scale Forging Tests Continued:

A. Fatigue Test Results Continued:

1. Forging (beta forged) Continued:

spectrum when a fatigue crack was noted during the application of the 3,000 lb. load, in the seventh application of the unit spectrum.

The test results obtained from this forging were compared with the results of the solution treated and aged Ti-6Al-4V forging previously tested in the Reference 3 programs. These data are:

<u>Type of Forging</u>	<u>Weight (lbs.)</u>	<u>Condition</u>	<u>Total Cycles To Failure</u>
Beta	9.01	Annealed	168,284
Alpha-beta (Ref. 3)	8.87	Solution Treated and Aged	172,100

III. Metallurgical Analysis:

A. Forging Cross Sections:

Sections 2L (Table I), 5K and 5L (Table 2) and 7L (Table 3) are shown in Figures 16 through 19.

As shown in Figures 16, 17, and 18 (beta forged items), much greater working is evident along the forging parting plane, especially in the web section (Figure 18). In general, tensile properties and ductility were higher in specimens machined from these sections (web and flange specimens in the data tables) than in specimens machined from the center section.

In the alpha-beta forged item (Figure 19), the very small grain size made the grain flow or pattern difficult to discern; however, the tensile properties and ductility were higher in the web and flange portions in this forging also. The data indicate that greater amounts of working produce higher tensile properties and ductility; however, specimens from all sections of the forgings showed satisfactory tensile properties.

The microstructures of the heavy center sections of forgings (beta forged and alpha-beta forged) are shown in Figure 20. These sections were cut

Test Results Continued

III. Metallurgical Analysis Continued:

A. Forging Cross Sections Continued:

from the upper flange (located in the heavy center section of the rough forging) of the finish machined forgings in the longitudinal grain direction. The microstructure for beta forged material indicates little platelet distortion or working in the heavy center section away from the forging parting plane. This location corresponds approximately to the circled area in Figure 16. The microstructure for the alpha-beta forging in Figure 20 shows evidence of working in the alpha-beta field with presence of rounded particles of primary alpha. These particles nucleate and grow while the material is being worked below the beta transus temperature. The location of this microstructure is shown in Figure 19 (circled area).

Microstructures in the heavy center section and flange transition section (transition zone between heavy center section and thinner section of forging) of beta forged material are shown in Figure 21. As noted above for beta forged material the blocky microstructure indicates little working in these locations.

Microstructures of the thinner section near one end of the rough beta forging (dotted lines in Figure 1, left end) are shown in Figure 22, and a considerable amount of grain distortion or working is evident. It was concluded that the amount of working in this portion of the forging was considerably greater than the amount of working in the heavy center sections examined (Figure 21).

B. Electron Beam Welded Specimen Microstructures:

Several of the electron beam welded smooth and notched tensile specimens (from the heavy center section of the forgings) were sectioned to confirm the location of the weldment in the test section and to examine the weldment quality. Sections through notched tensile specimens (one each from the beta and alpha-beta forged parts) are shown in Figures 23 and 24; and sections through smooth specimens are shown in Figure 25. The weldments were clean and free of porosity and were located at the notch. The smooth specimens failed away from the weldment, indicating that the weldment and heat affected zone were stronger than the basis metal.

Test Results Continued

IV. Chemical Analysis:

Chemical composition of the beta and alpha beta forgings tested in this study were within specification requirements and these data are presented in Table 5.

ACKNOWLEDGEMENTS

The valuable assistance of the following personnel in planning and conducting tests and evaluating the test results is gratefully acknowledged:

Messrs. W. Bush, R. Urzi, and R. Muego (mechanical properties and fatigue testing), R. Ketola, S. Branton (full-scale static and fatigue testing), R. Adamson, S. Pendleberry, D. Runner (mechanical properties, bearing, and fracture toughness tests) and Miss J. Gottbrath (planning) all of the Rye Canyon Research Laboratory. Electron beam welding was performed under the direction of M. L. Ochieano and special assistance in the reporting phase was provided by J. Pengra, Production Engineering Division.

REFERENCES

- (1) "A Manual on Fundamentals of Forging Practice," Battelle Memorial Institute AF 33(600)-42963 for WPAFB, Ohio, Dec. 1964, pp. 215-218.
- (2) "Beta Forging Titanium," O. H. Cook and S. W. McClaren, 2/9/68, TN Memorandum 2-59210/8TM-2, Vought Aeronautics Division, LTV, Dallas (Westec Conference 1968, Los Angeles).
- (3) "High Strength Titanium Alloy Die Forgings" by R. F. Simenz and W. L. Macoritto, presented at the Westec Conference, Los Angeles, 1966.

TABLE 1

SUMMARY OF MECHANICAL PROPERTIES OF BETA FORGING (AVERAGE VALUES)

SHORT
TRANSVERSE

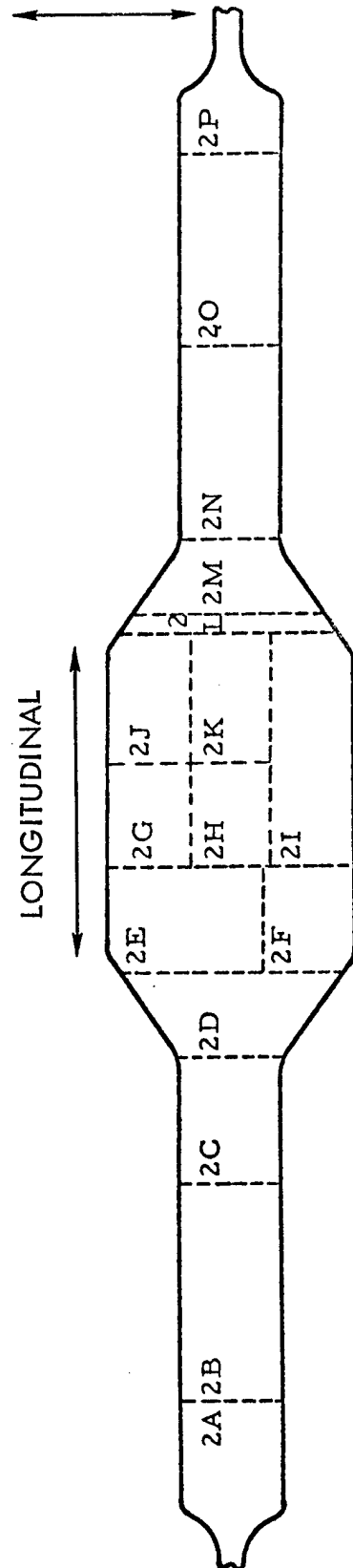

SMOOTH TENSILE

	F_{tu}	F_{ty}	EL.	R.A.
	KSI	KSI	%	%
LONG. (ROOM TEMP.)				
SECTION 2C	145.9	136.6	12.6	30.3
SECTION 2F	138.3	125.8	12	27.6
TRANS. (ROOM TEMP.)				
SECTION 2B	147.7	139.1	14	38.6
SECTION 2C	142.3	134.5	12.6	33
SECTION 2F	138.4	127	12.6	29.3
SHORT TRANS. (ROOM TEMP.)				
SECTION 2C	146.2	137.5	12.6	30.6
SECTION 2E	139.7	127.3	11.3	24.3
SHORT TRANS. (-110° F)				
SECTION 2E	164	151.3	9.6	23

NOTCHED TENSILE ($K_t = 3$)

	KSI	NTS/ F_{tu}
LONG. (ROOM TEMP.)		
SECTION 2F	211.7	1.53
TRANS. (ROOM TEMP.)		
SECTION 2F	211	1.53
SHORT TRANS. (ROOM TEMP.)		
SECTION 2E	211	1.52
SHORT TRANS. (-110° F)		
SECTION 2E	253.6	1.55

COMPRESSION

	F_{cy} KSI
LONG. (ROOM TEMP.)	
SECTION 2E	134.8
TRANS. (ROOM TEMP.)	
SECTION 2F	136.3

FRACTURE TOUGHNESS

	K_{Ic} (KSI \sqrt{in})
SHORT TRANS. (ROOM TEMP.)	
SECTION 2E	94
SHORT TRANS. (-110° F)	
SECTION 2E	103

E.B. WELDED NOTCHED TENSILE ($K_t = 3$)

	KSI
LONG. (ROOM TEMP.)	
SECTIONS 2GJ	195
SECTIONS 2HK	191

TABLE 2

SUMMARY OF MECHANICAL PROPERTIES OF BETA FORGING (AVERAGE VALUES)

SHORT
TRANSVERSE

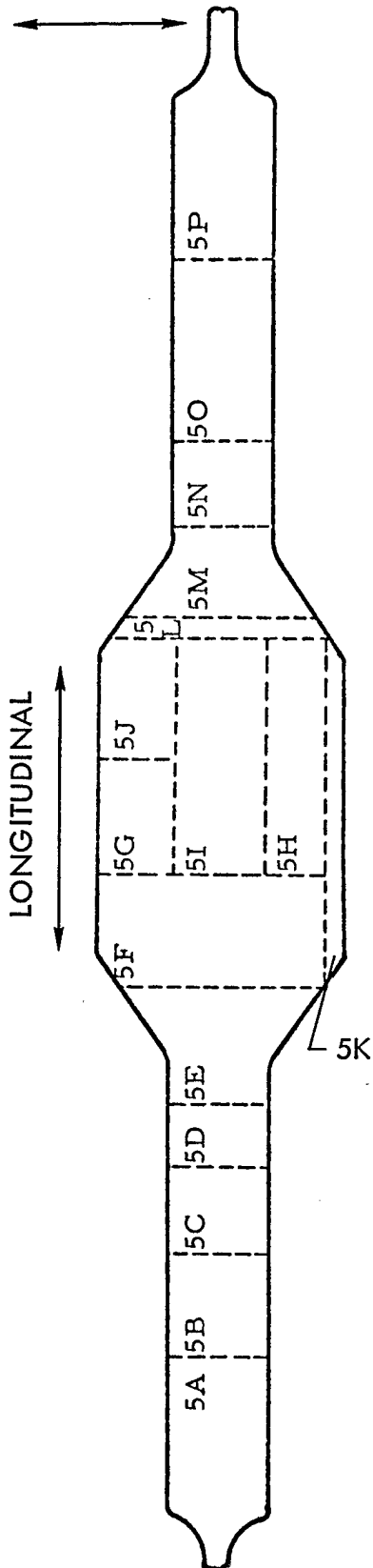

SMOOTH TENSILE

	F_{tu} KSI	F_{ty} KSI	EL. %	R.A. %
LONG. (ROOM TEMP.)				
SECTION 5FA	141.4	129.6	13	29
SECTION 5FB	142.8	130.2	12	25.6
SECTION 5C	151.2	144.5	14.5	37
SECTION 5N	150.9	142.4	14	37
TRANS. (ROOM TEMP.)				
SECTION 5HB	139.0	125.4	12.0	26.0
SECTION 5B	147.1	137.2	14.0	37.5
SECTION 5C	147.9	137.9	15.0	34.0
SECTION 5D	145.5	132.5	13.5	31.5
SECTION 5N	142.3	132.9	13	38
SHORT TRANS. (ROOM TEMP.)				
SECTION 5FA	141.0	128.4	11.6	26.6
SECTION 5D	149.5	137.9	12.3	23.6
LONG. (-110° F)				
SECTION 5B	174	167	13.0	29.0
SECTION 5FB	162.3	152	11.3	24.0
SECTION 5N	169	153	8	18.
TRANS. (-110° F)				
SECTION 5HB	159.6	144.6	10.3	23.3

NOTCHED TENSILE ($K_t=3$)

	KSI	NTS/ F_{tu}
LONG. (ROOM TEMP.)		
SECTION 5C	223	1.47
SECTION 5HB	207.6*	
SECTION 5N	228	1.51
TRANS. (ROOM TEMP.)		
SECTION 5B	231	1.57
SECTION 5C	230	1.55
SECTION 5D	222	1.53
SECTION 5N	224	1.57
SHORT TRANS. (ROOM TEMP.)		
SECTION 5D	217.3	1.46
LONG. (-110° F)		
SECTION 5B	267.5	1.54
SECTION 5FA	252	1.55
SECTION 5N	259	1.53
TRANS. (-110° F)		
SECTION 5HB	247.6	1.55

* $K_t = 3.9$

TABLE 2
 SUMMARY OF MECHANICAL PROPERTIES OF BETA
 FORGING (AVERAGE VALUES)

<u>SHEAR</u>			
LONG. (ROOM TEMP.)		KSI	
SECTION 5HB _____		88.4	
 <u>BEARING</u>			
		F_{bru}	F_{bry}
LONG. (ROOM TEMP.)		KSI	KSI
SECTION 5HA _____		288	230
 E.B. WELDED NOTCHED TENSILE ($K_t = 3$)			
LONG. (ROOM TEMP.)		KSI	
SECTION 5GJ _____		176	

TABLE 3

SUMMARY OF MECHANICAL PROPERTIES OF ALPHA BETA FORGING (AVERAGE VALUES)

SHORT
TRANSVERSE

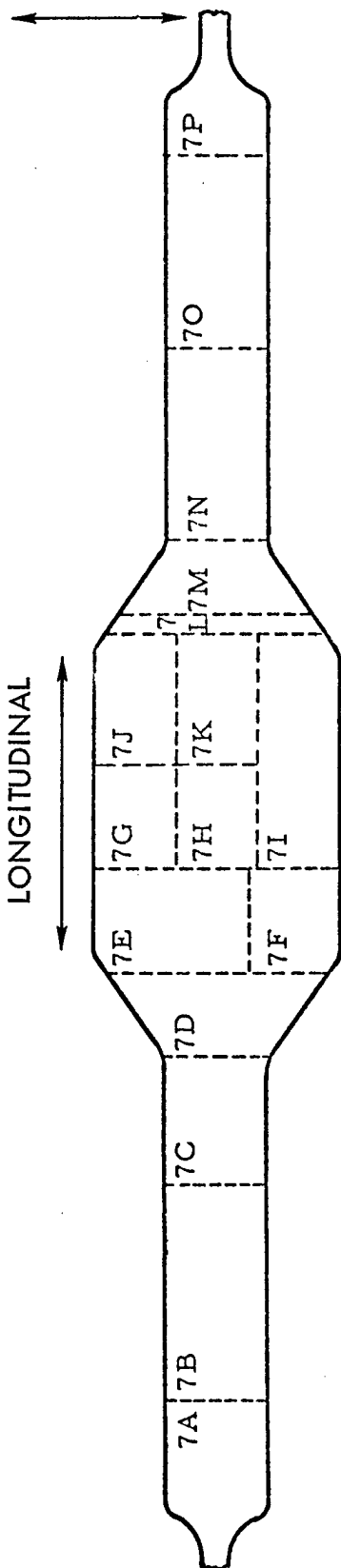

SMOOTH TENSILE

	F_{tu}	F_{ty}	EL.	R.A.
LONG. (ROOM TEMP.)	KSI	KSI	%	%
SECTION 7C	147.7	141.8	15	43.6
SECTION 7F	137.7	129.2	15.3	34.3
TRANS. (ROOM TEMP.)				
SECTION 7B	149.6	143.3	15.3	43.3
SECTION 7C	139.9	132.2	16	45
SECTION 7F	136.1	126.8	14	32
SHORT TRANS. (ROOM TEMP.)				
SECTION 7C	148.4	140.9	15.3	42.6
SECTION 7E	140.9	132.3	15.3	35.6
SHORT TRANS. (-110°F)				
SECTION 7E	169.6	163	13.0	33.3

NOTCHED TENSILE ($K_t = 3$)

	KSI	NTS/ F_{tu}
LONG. (ROOM TEMP.)		
SECTION 7F	212.3	1.54
TRANS. (ROOM TEMP.)		
SECTION 7F	209.3	1.54
SHORT TRANS. (ROOM TEMP.)		
SECTION 7E	213	1.51
SHORT TRANS. (-110°F)		
SECTION 7E	254	1.50

COMPRESSION

	F_{cy} KSI
LONG. (ROOM TEMP.)	
SECTION 7E	142.2
TRANS. (ROOM TEMP.)	
SECTION 7F	137.8

FRACTURE TOUGHNESS

	K_{Ic} (KSI \sqrt{in})
SHORT TRANS. (ROOM TEMP.)	
SECTION 7E	82
SHORT TRANS. (-110°F)	
SECTION 7E	82

E.B. WELDED NOTCH TENSILE ($K_t = 3.0$)

	KSI
LONG. (ROOM TEMP.)	
SECTION 7GJ	195
SECTION 7HK	192

SPECIMEN NUMBER	GRAIN DIRECTION	LOCATION	F _{tu} (KSI)	F _{ty} (KSI)	% ELONGATION (2" G.L.)	% REDUCTION OF AREA
2GJ-3	L	MR	138	123	11	23
2HK-4	L	CENTER	140	128	12	28
AVG.			139	126	11.5	26
5GJ-9	L	MR	138	123	11	22
AVG.			138	123	11	22
7GJ-3	L	MR	140	132	11	29
7HK-4	L	CENTER	136	129	15	32
AVG.			138	131	13	31

TABLE 4 RESULTS OF ROOM TEMPERATURE SMOOTH TENSILE TESTS ON
ELECTRON BEAM WELDED SPECIMENS

ELEMENT	SPECIFICATION REQUIREMENTS (LAC-C-05-1094) %	(β FORGED) %	(α - β FORGED) %
Al	5.50 - 6.75	6.73	6.63
V	3.50 - 4.50	4.17	4.21
FE	0.30 MAX.	0.10	0.08
O	0.15 - 0.20	0.15	0.18
C	0.10 MAX.	0.026	0.035
N	0.50 MAX.	0.029	0.040
H	0.0125 MAX.	0.0057	0.0063
O.E.	0.10 MAX. (EACH)	OK	OK
T.O.E.	0.40 MAX.	OK	OK
Ti	REMAINDER	REMAINDER	REMAINDER

TABLE 5 RESULTS OF CHEMICAL ANALYSES OF FORGINGS

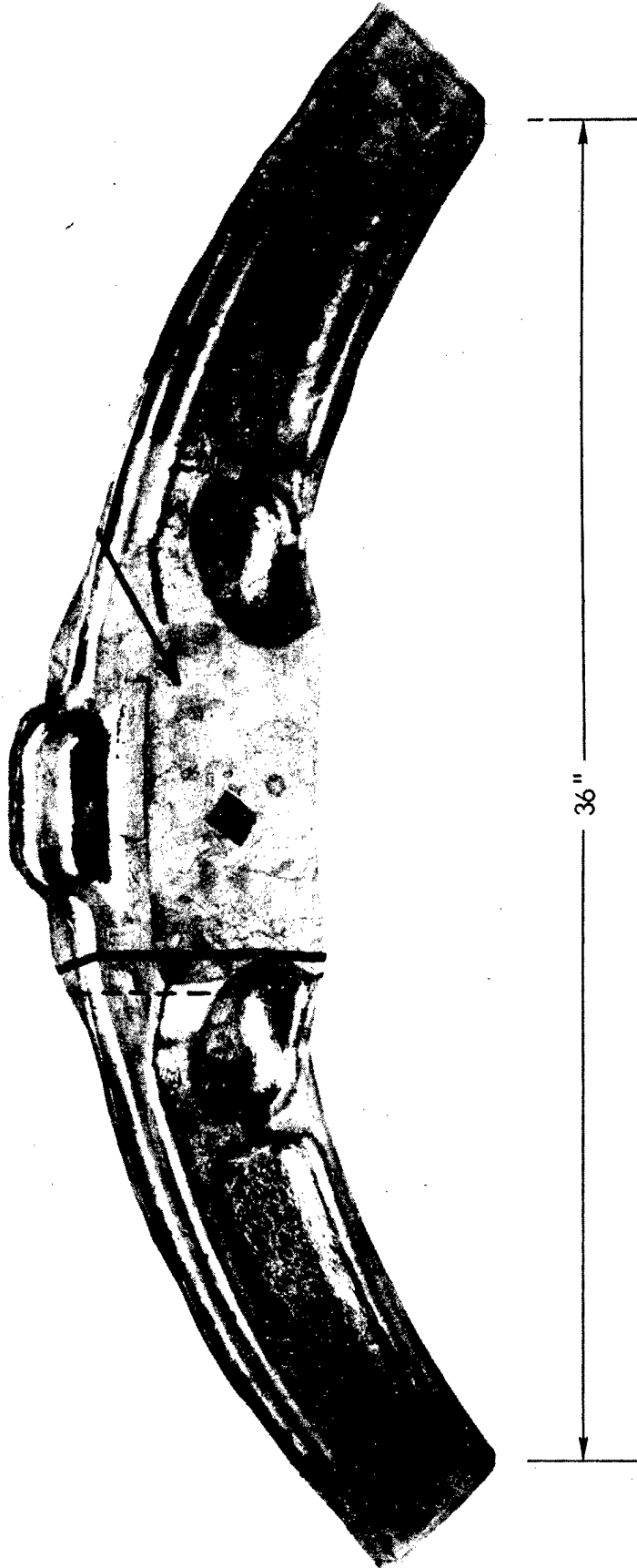

FIGURE 1 - TYPICAL ROUGH FORGING PROCESSED ABOVE THE BETA TRANSUS TEMPERATURE.

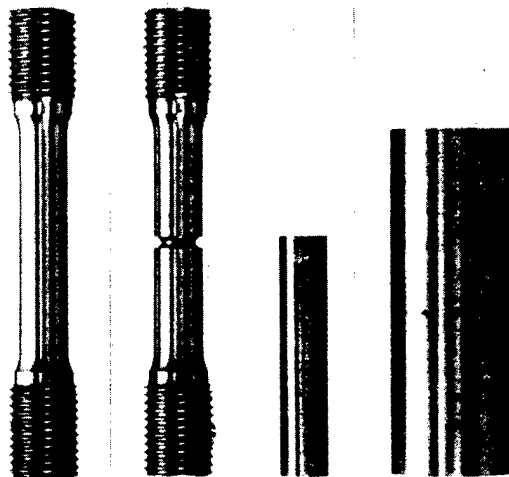

FIGURE 2 - TEST SPECIMENS (LEFT TO RIGHT) (TENSILE),
(NOTCHED TENSILE), (SHEAR), AND
(COMPRESSION).

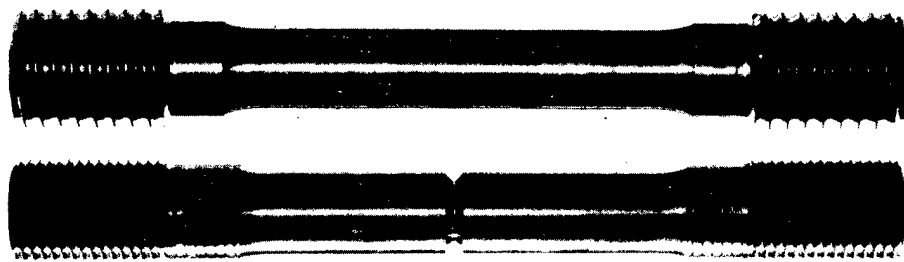

FIGURE 3 - TEST SPECIMENS (TENSILE) AND (NOTCHED
TENSILE) FOR THE ELECTRON BEAM WELDMENT TESTS.

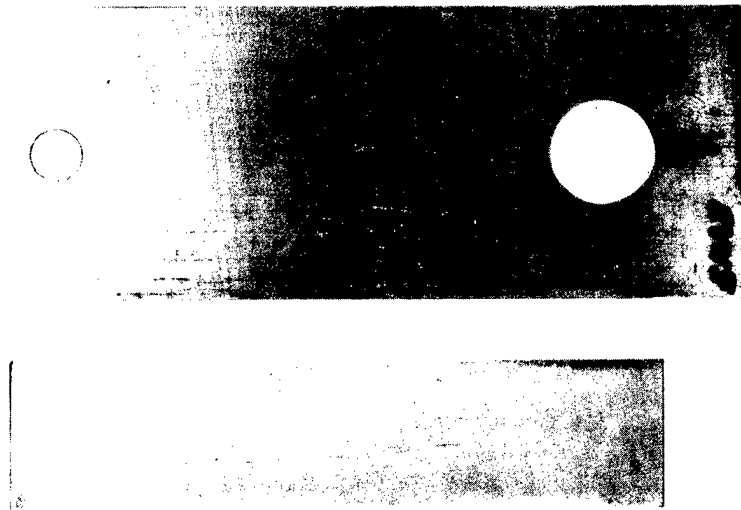

FIGURE 4 - TEST SPECIMENS (BEARING) (UPPER PHOTO) AND (FRACTURE TOUGHNESS) (LOWER PHOTO).

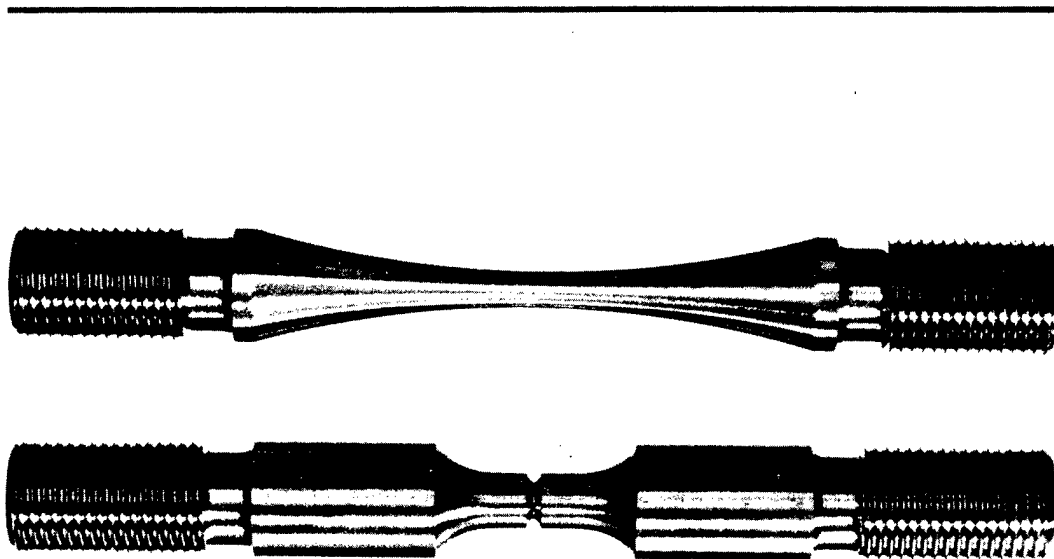

FIGURE 5 - TEST SPECIMENS (FATIGUE) AND (NOTCHED FATIGUE).

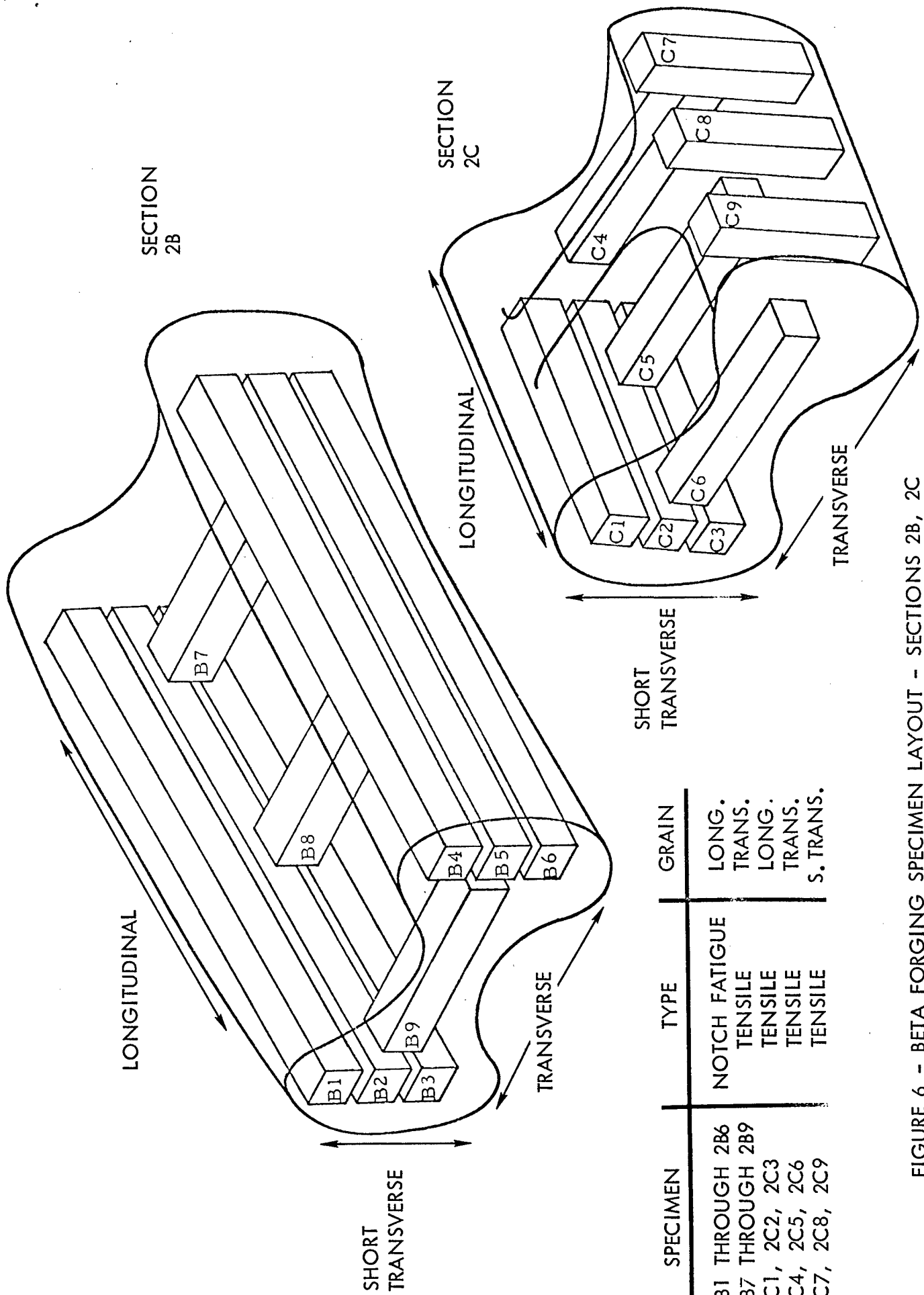

FIGURE 6 - BETA FORGING SPECIMEN LAYOUT - SECTIONS 2B, 2C

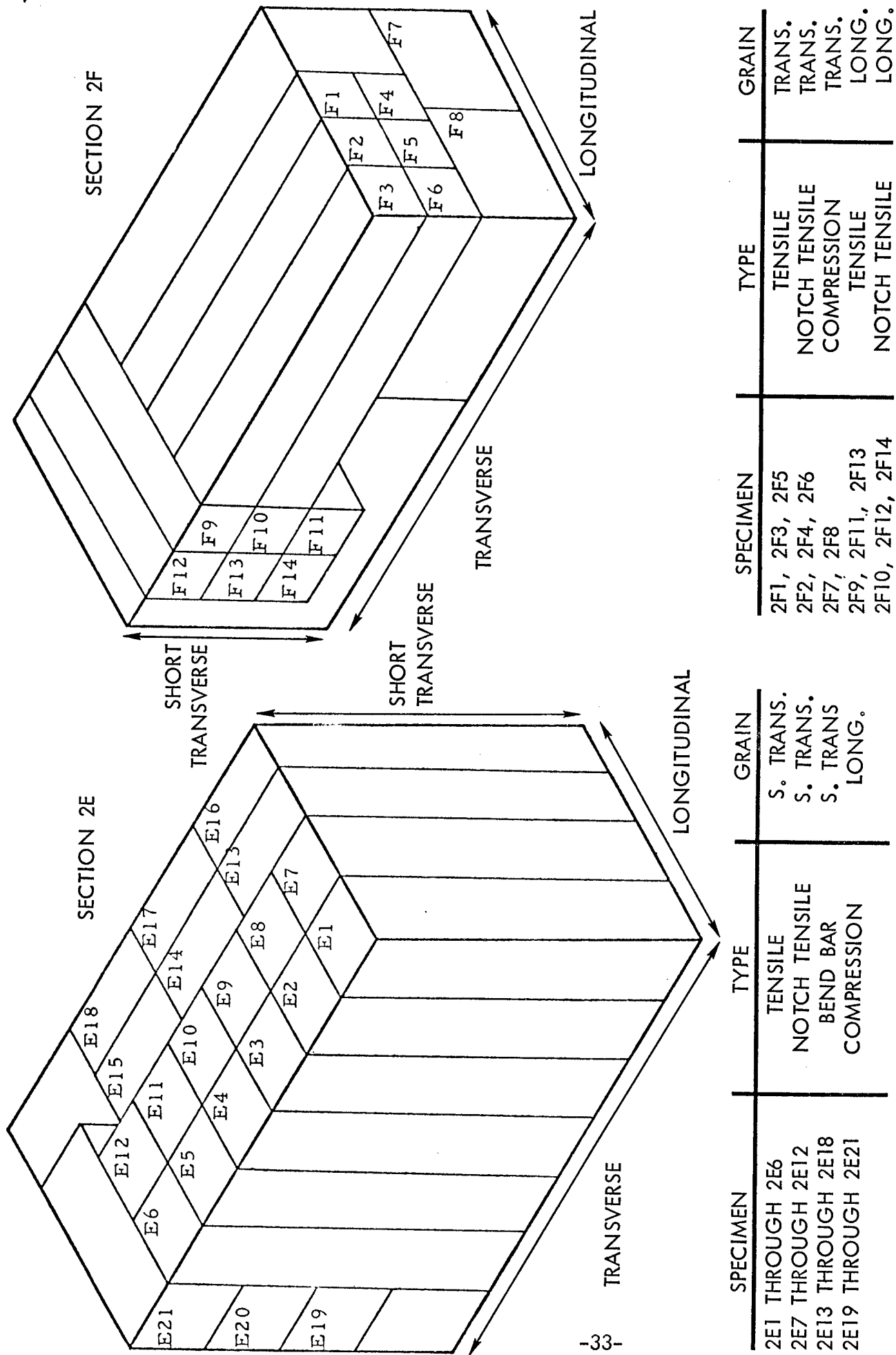
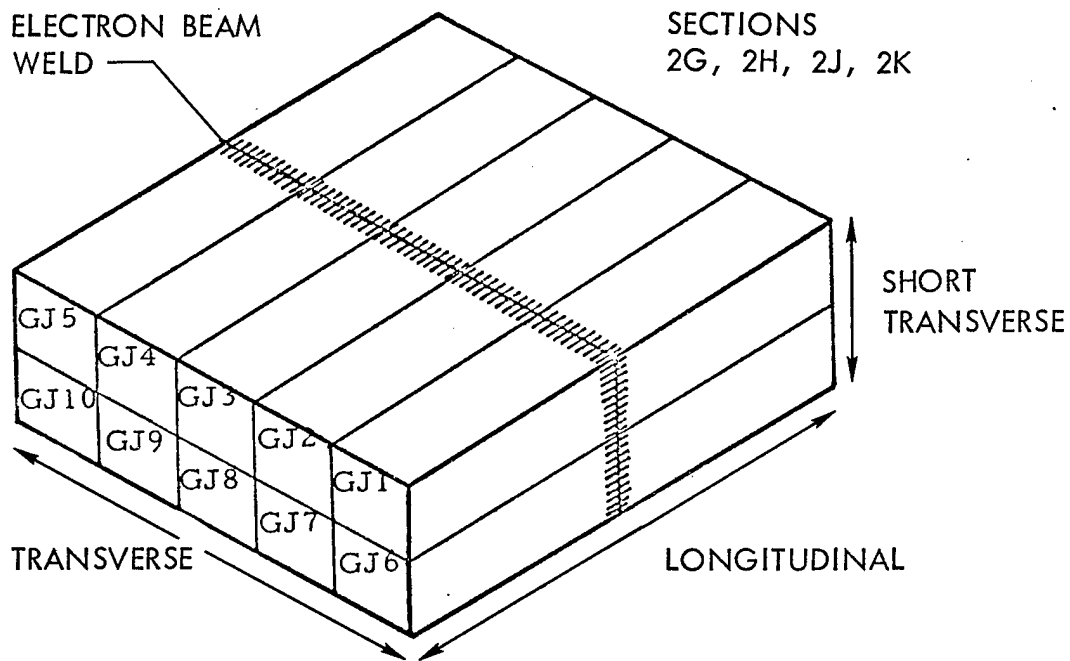
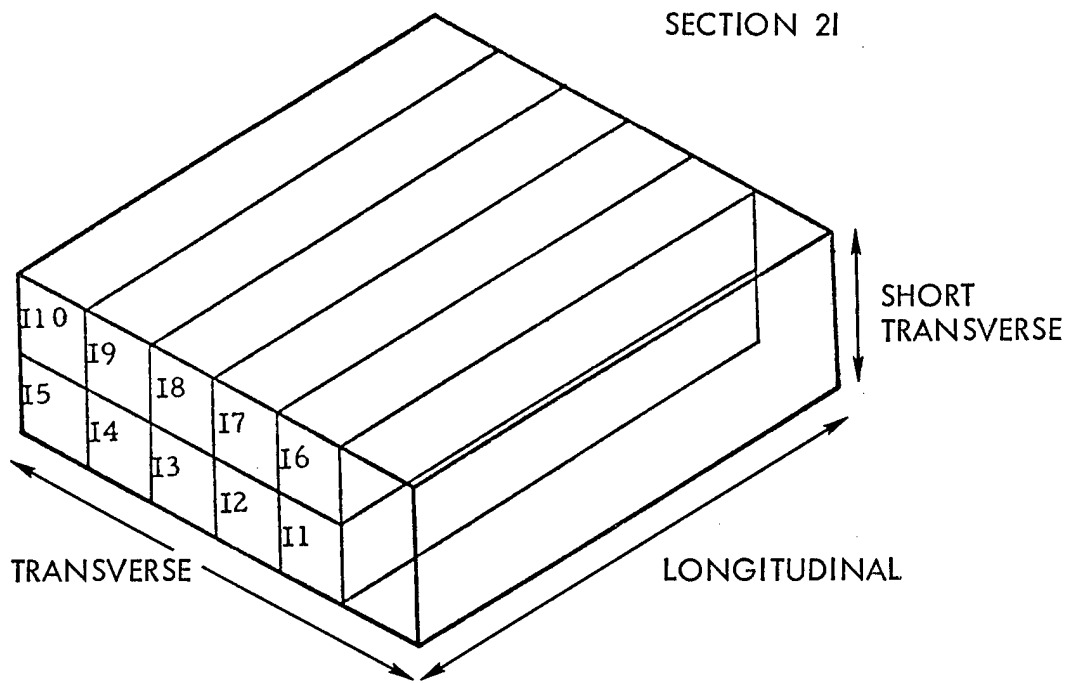

FIGURE 7 - BETA FORGING SPECIMEN LAYOUT - SECTIONS 2E, 2F



SPECIMEN	TYPE	GRAIN
2I1, 2I3, 2I5, 2I7, 2I9	FATIGUE	LONG.
2I2, 2I4, 2I6, 2I8, 2I10	NOTCH FATIGUE	LONG.
2GJ1, 2GJ4, 2GJ8, 2HK2, 2HK9	E. B. WELD FATIGUE	LONG.
2GJ2, 2GJ5, 2GJ6, 2GJ9, 2HK3, 2HK6, 2HK8, 2HK10	E. B. WELD NOTCH FATIGUE	LONG.
2GJ3, 2HK4	E. B. WELD TENSILE	LONG.
2GJ7, 2GJ10, 2HK1, 2HK5, 2HK7	E. B. WELD NOTCH TENSILE	LONG.

FIGURE 8 - BETA FORGING SPECIMEN LAYOUT - SECTIONS 2I, 2G, 2H, 2J, 2K

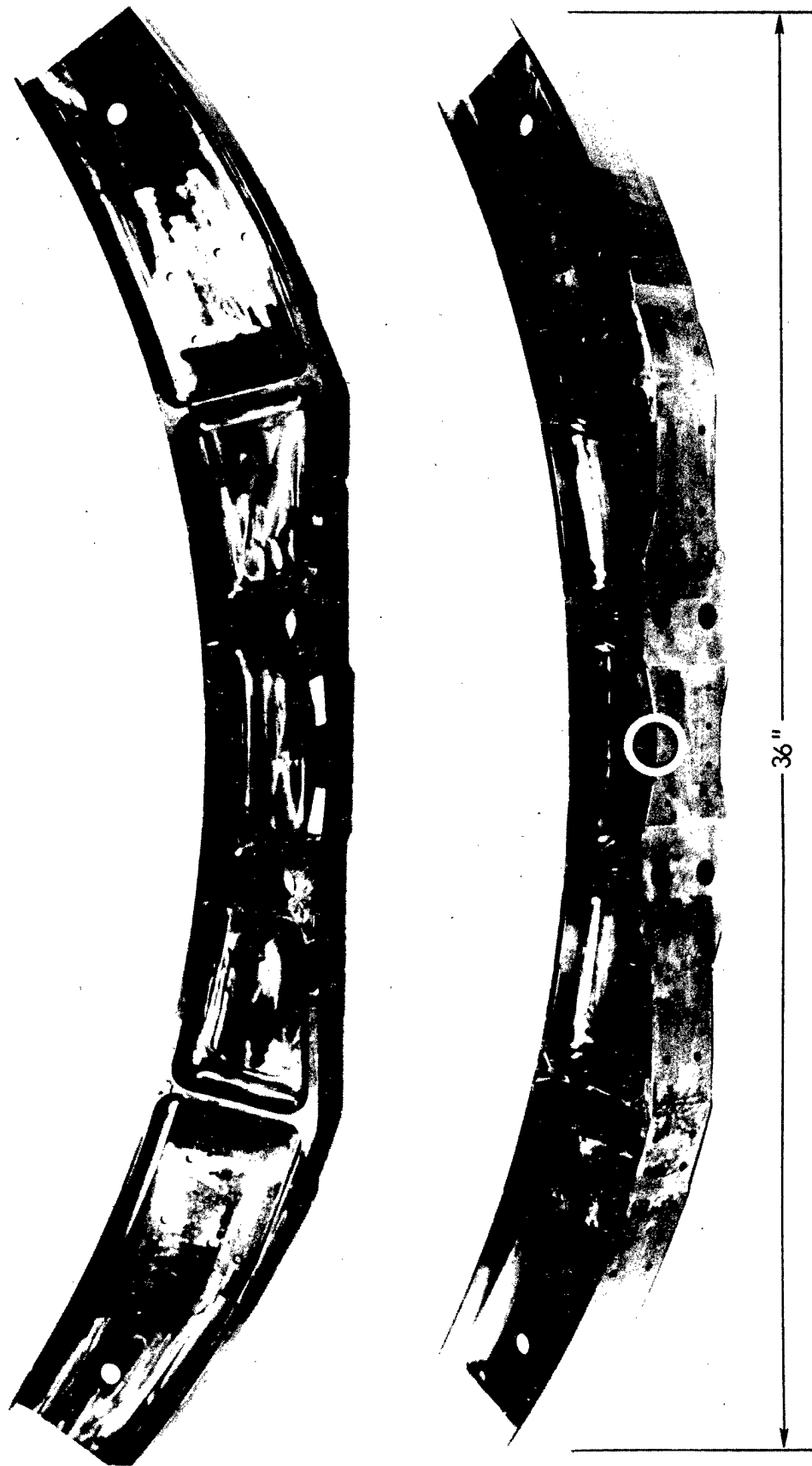

FIGURE 9 - TYPICAL MACHINED ALPHA-BETA FORGING READY FOR FULL-SCALE SPECTRUM FATIGUE TESTING. CIRCLED AREA IS LOCATION OF MICROSTRUCTURE SHOWN IN FIG. 20.

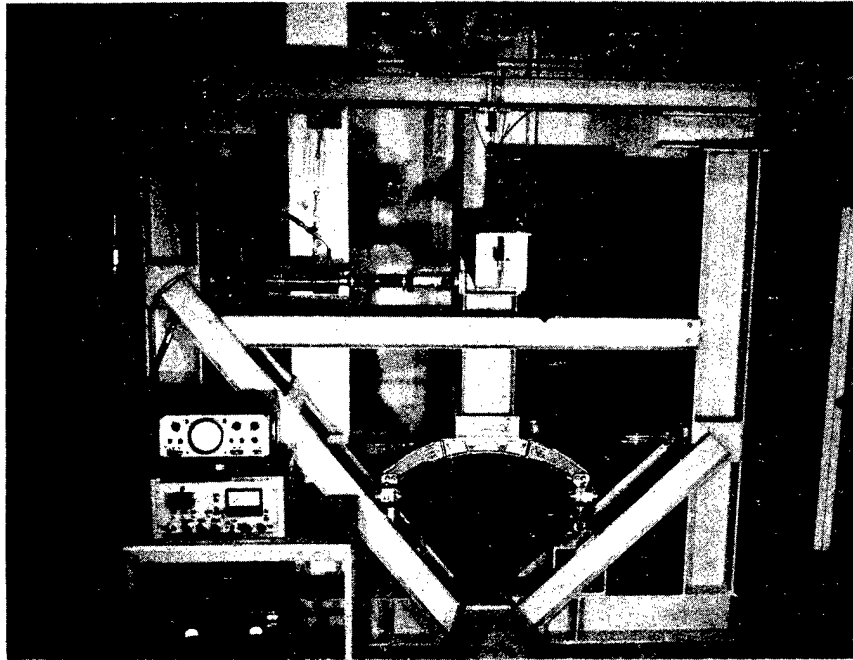
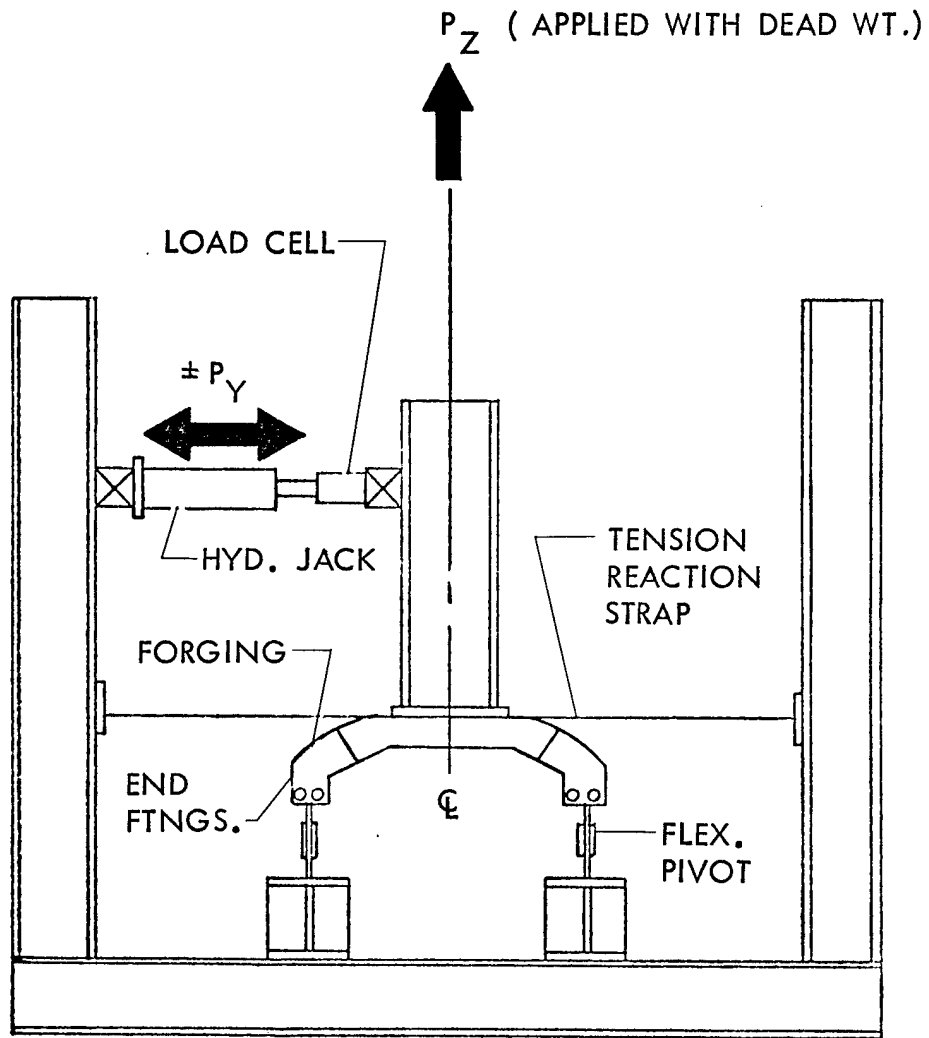

FIGURE 10 - FATIGUE TEST SETUP WITH TEST FORGING IN PLACE.



NOTE: P_Y LOAD APPLIED 30 IN. FROM TOP DECK OF FORGING

FIGURE 11 SCHEMATIC OF FATIGUE TEST SET-UP

TI-6Al-4V FORGING
 MILL ANNEALED
 TEST TEMP.: ROOM
 RANGE RATIO: $R = 0.1$
 GRAIN: LONGITUDINAL,
 AND SHORT TRANSVERSE

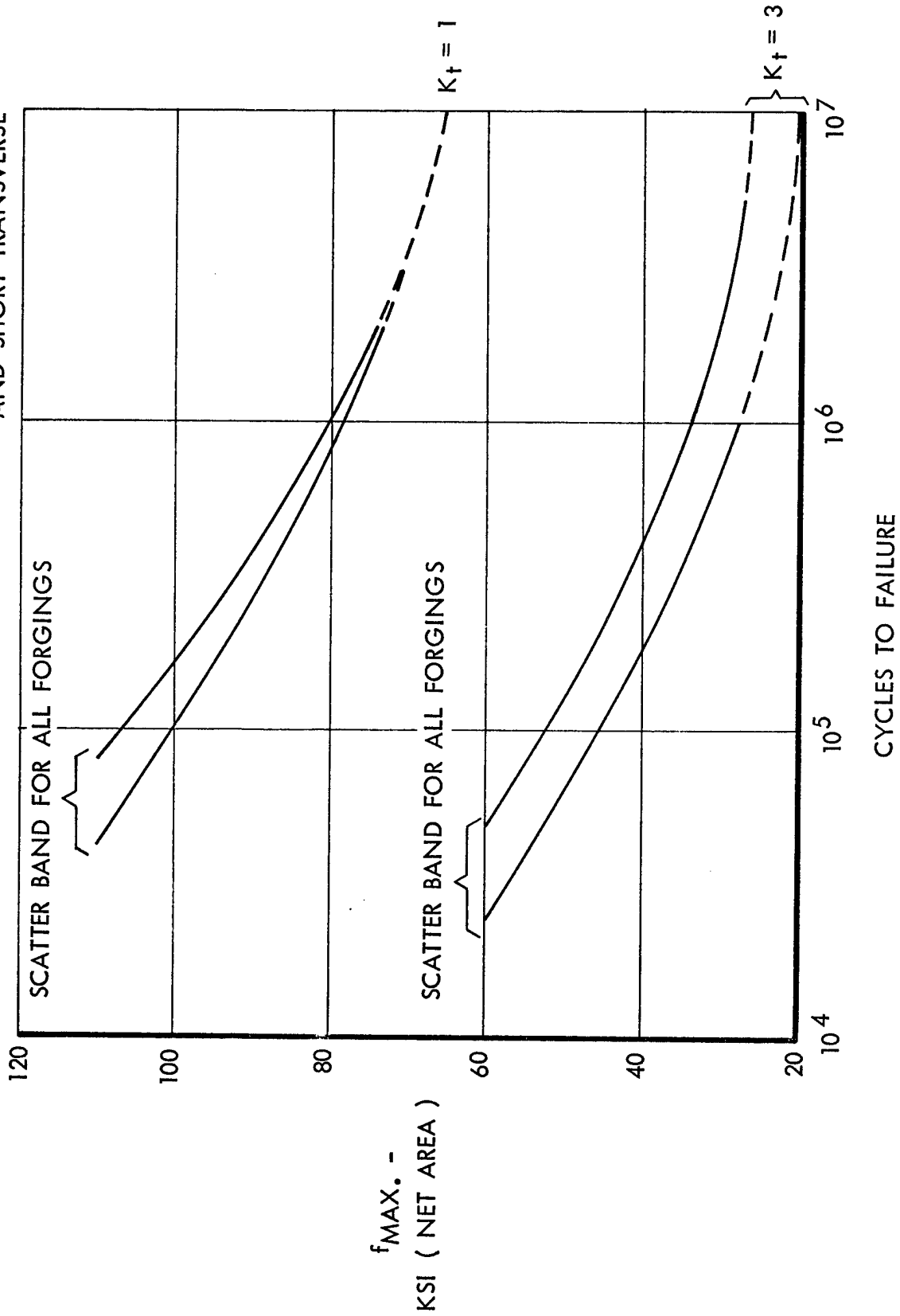

FIGURE 12 - TI-6Al-4V BETA FORGING STUDY (SUMMARY)

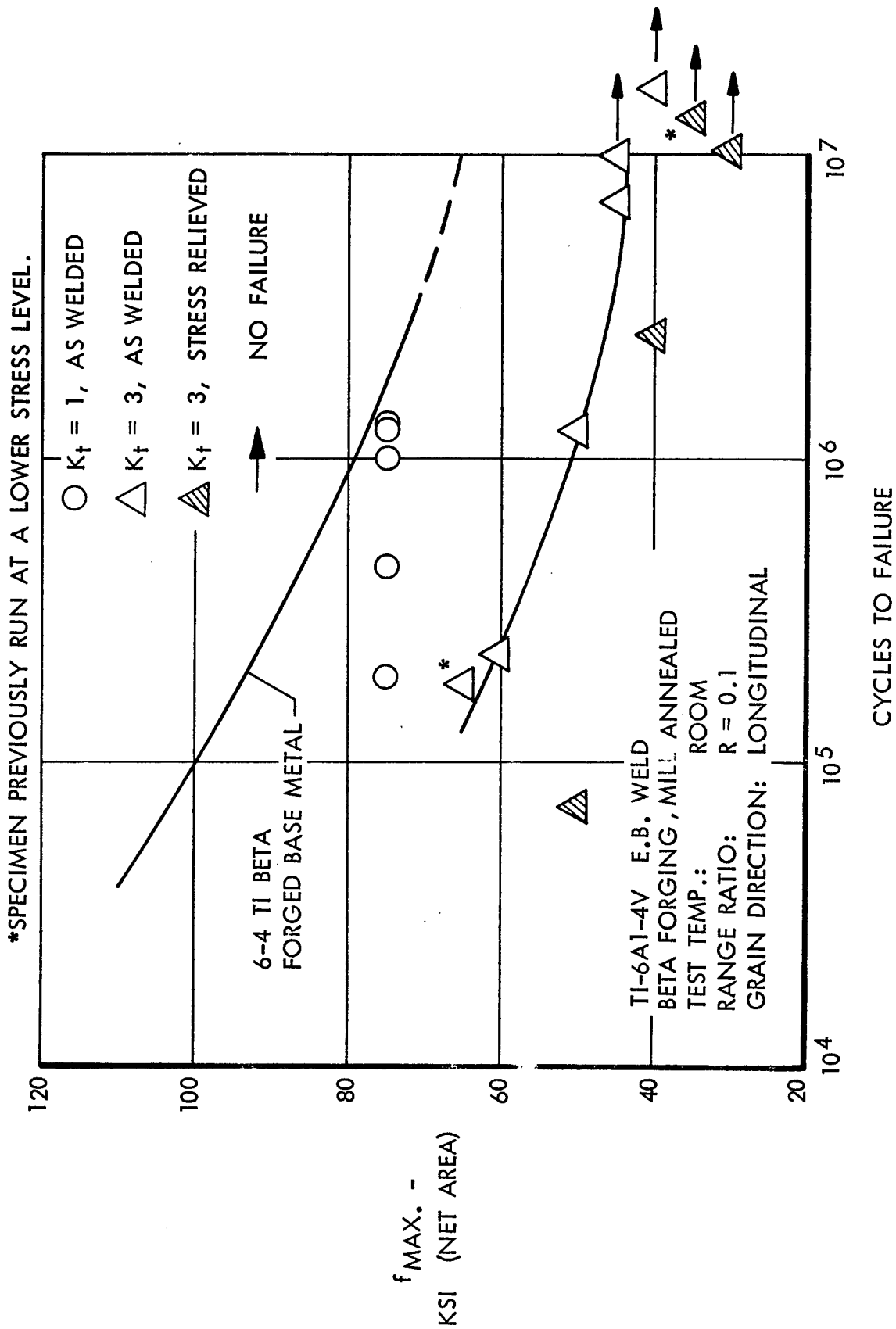
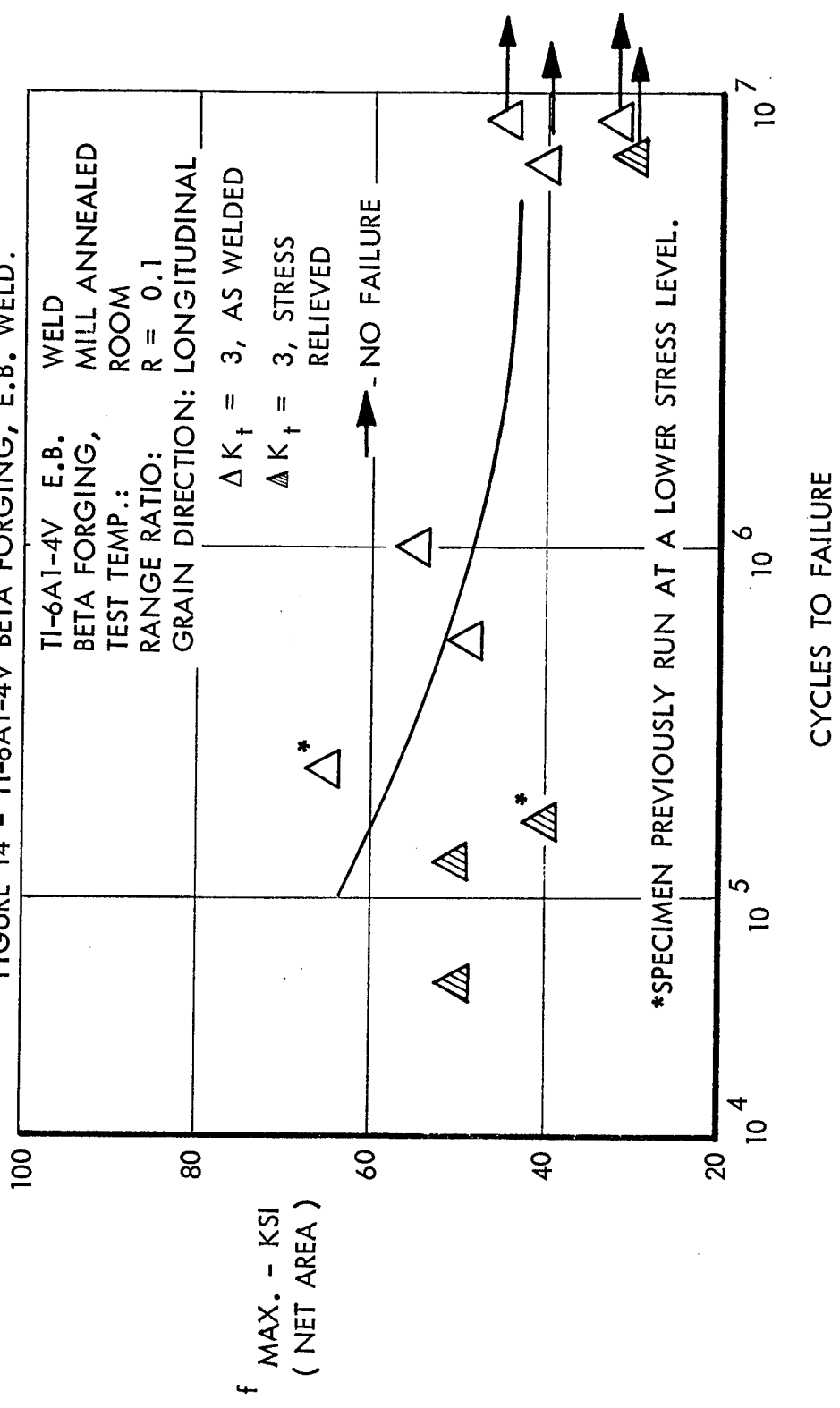

FIGURE 13 - TI-6Al-4V BETA FORGING, E.B. WELD.

FIGURE 14 - TI-6Al-4V BETA FORGING, E.B. WELD.



TI-6Al-4V E.B. WELD
 ALPHA BETA FORGING, MILL ANNEALED
 TEST TEMP.: ROOM
 RANGE RATIO: $R = 0.1$
 GRAIN DIRECTION: LONGITUDINAL

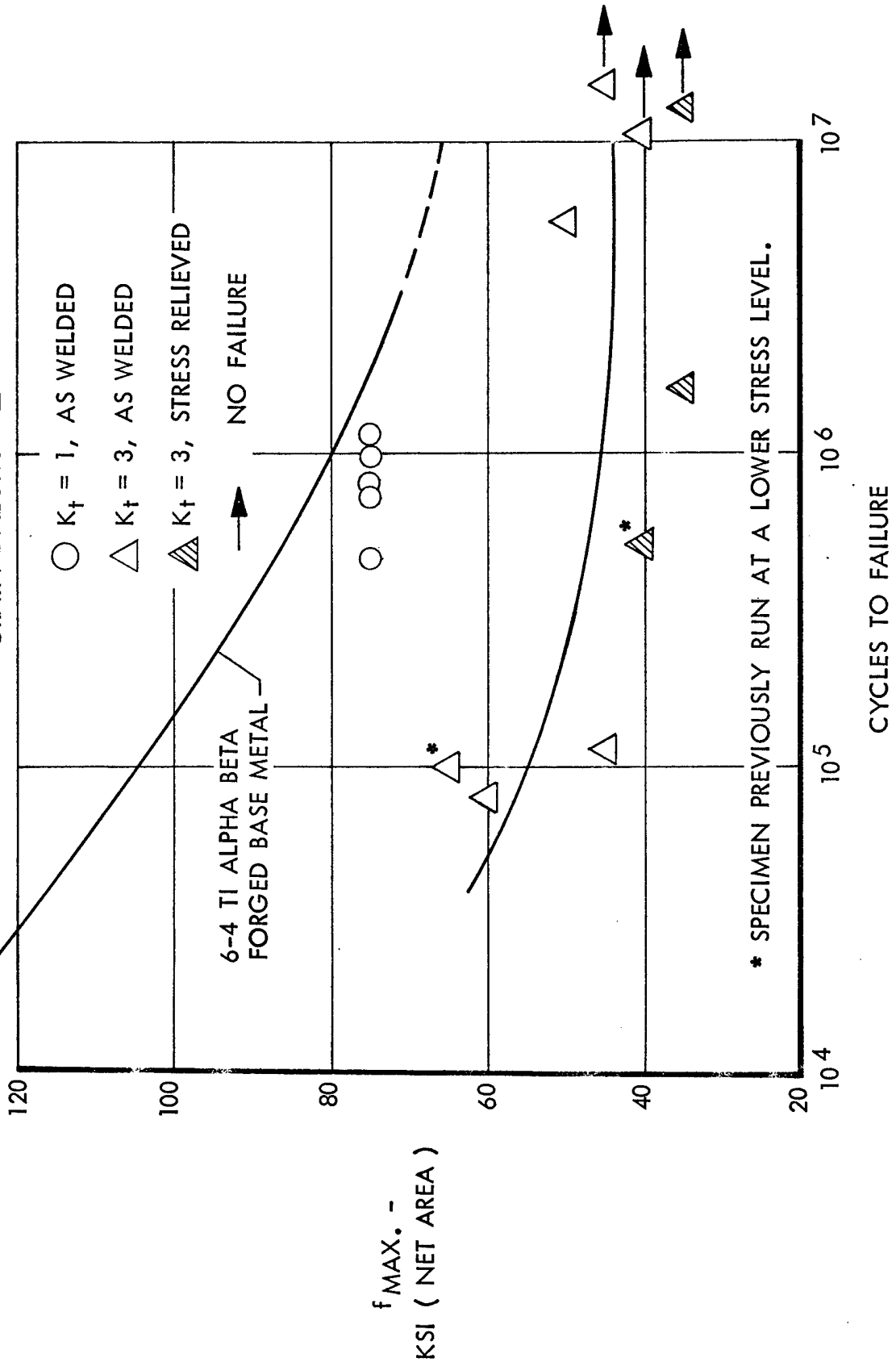
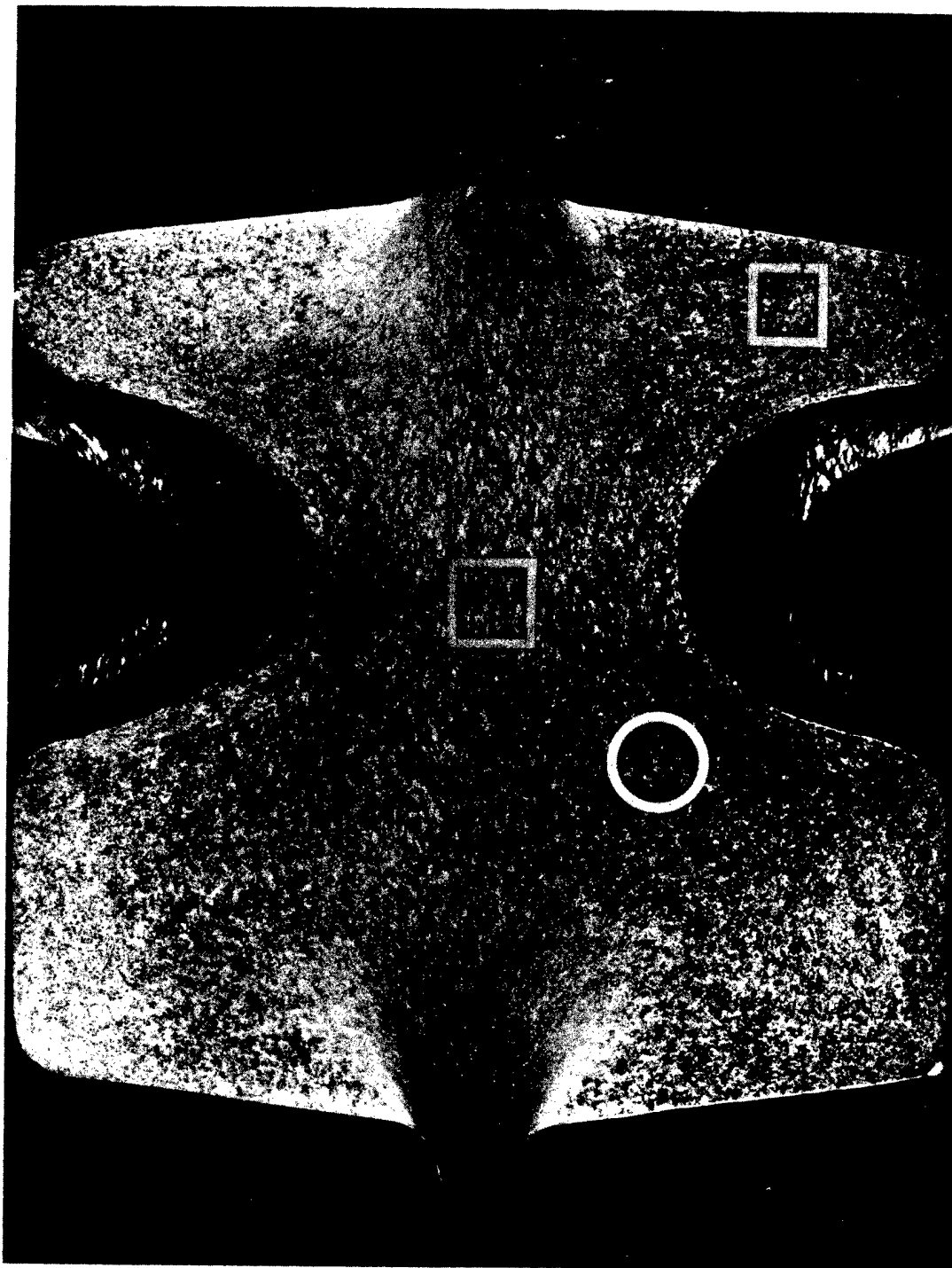
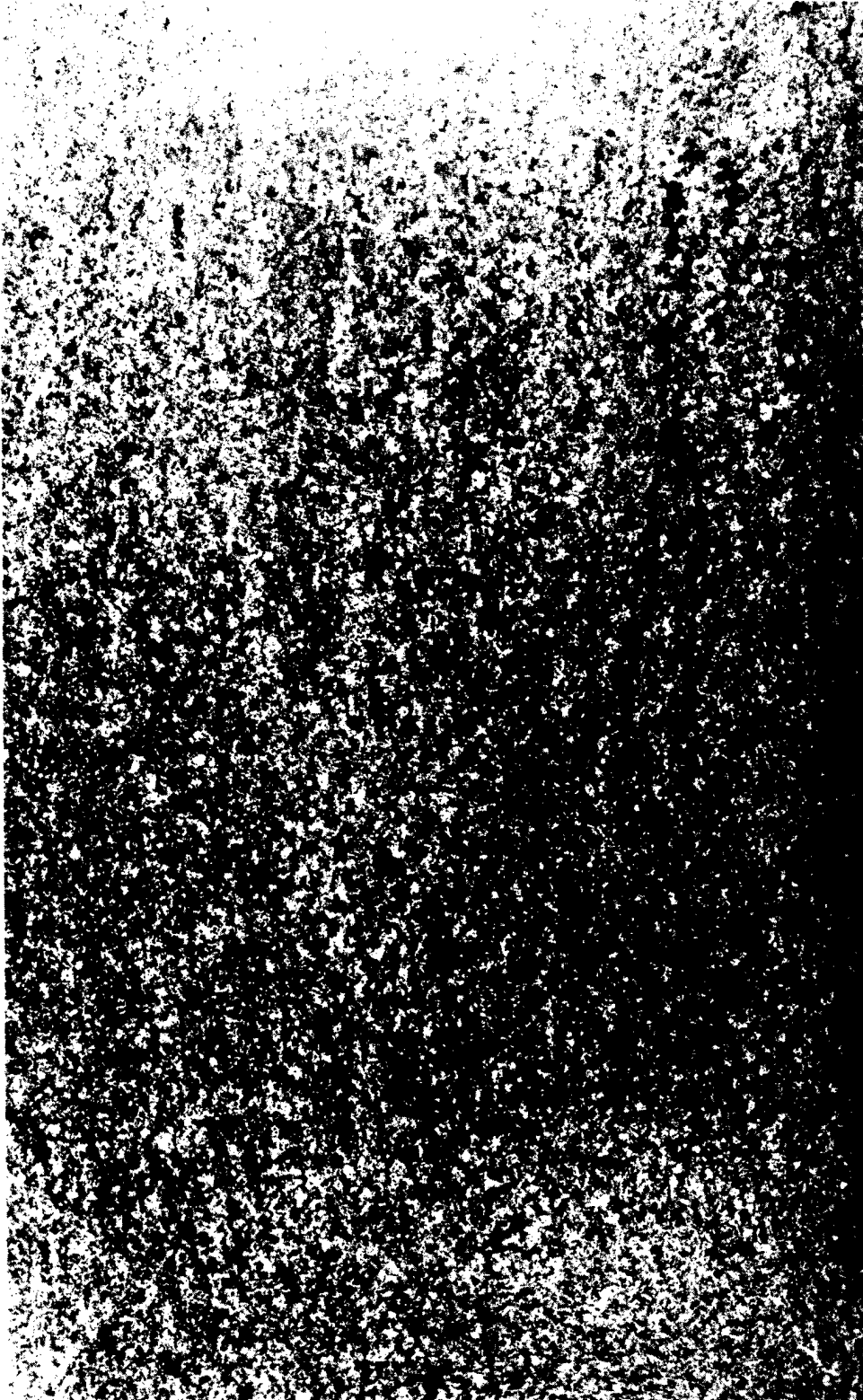

FIGURE 15 - TI-6Al-4V ALPHA BETA FORGING, E.B. WELD.



6"

FIGURE 16 - SECTION CUT THROUGH HEAVY (ADJACENT TO) CENTER PORTION OF FORGING (BETA FORGED) TO SHOW GRAIN FLOW PATTERN (TRANSVERSE). CIRCLED AREA IS THE LOCATION OF THE MICROSTRUCTURE SHOWN IN FIGURE 20. SQUARED AREAS ARE SHOWN IN FIGURE 21.



7"

FIGURE 17 - SECTION CUT ALONG THE SIDE OF THE HEAVY CENTER PORTION OF FORGING (BETA FORGED) TO SHOW GRAIN FLOW PATTERN (LONGITUDINAL).

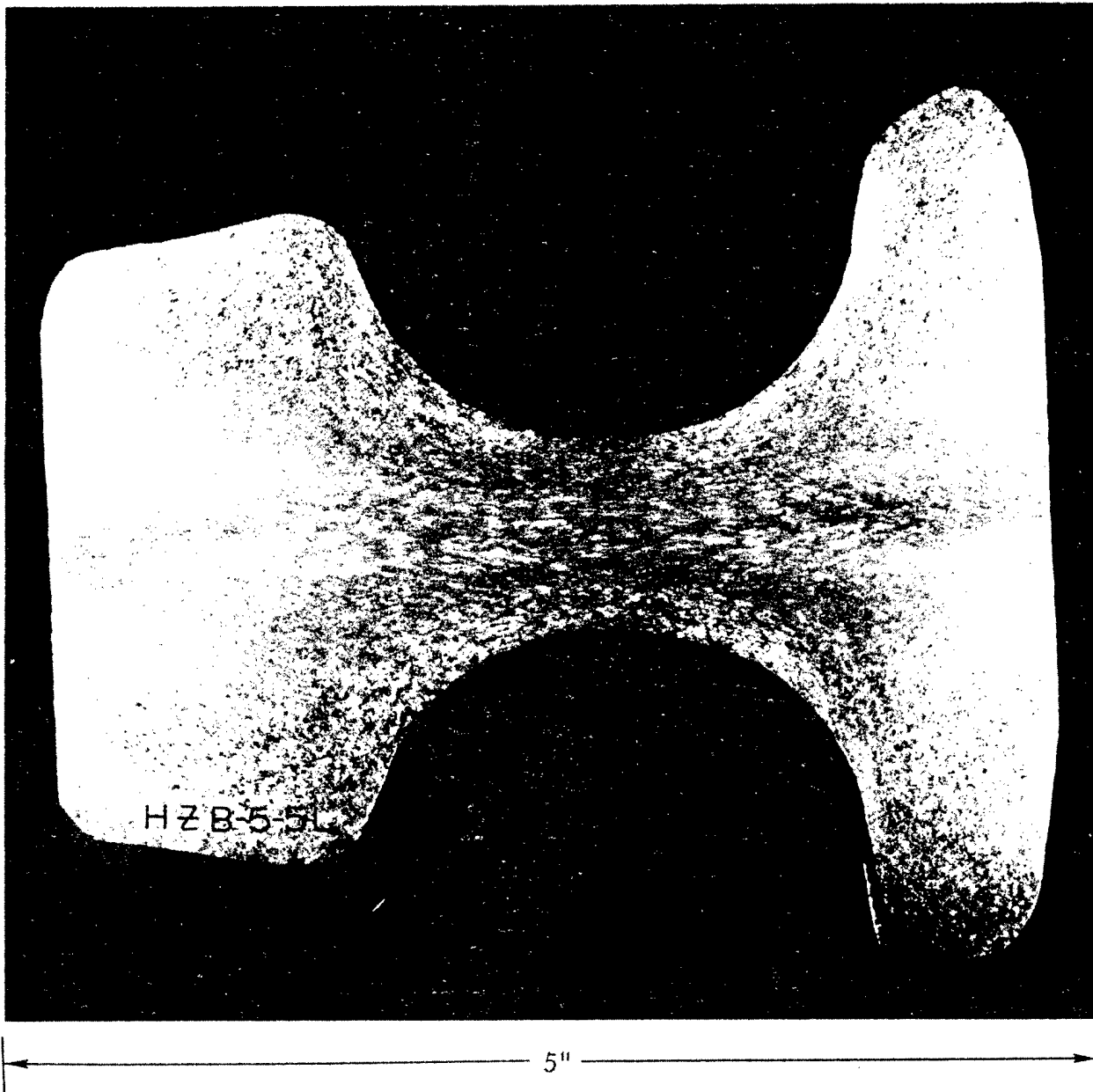

FIGURE 18 - SECTION CUT THROUGH TRANSITION ZONE FROM THE HEAVY CENTER PORTION TO THE THINNER LEG PORTION OF FORGING (BETA FORGED) TO SHOW GRAIN FLOW PATTERN (TRANSVERSE).

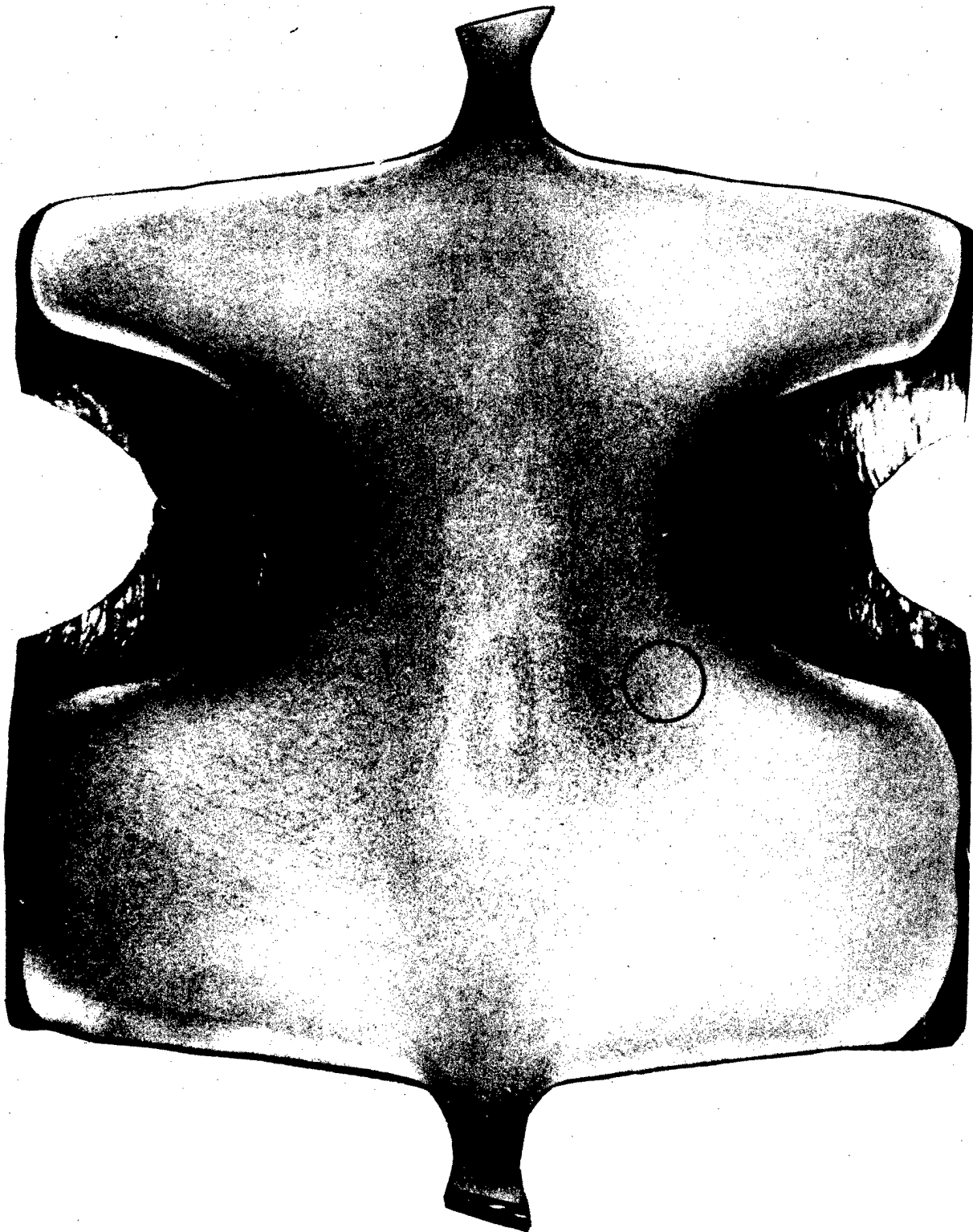
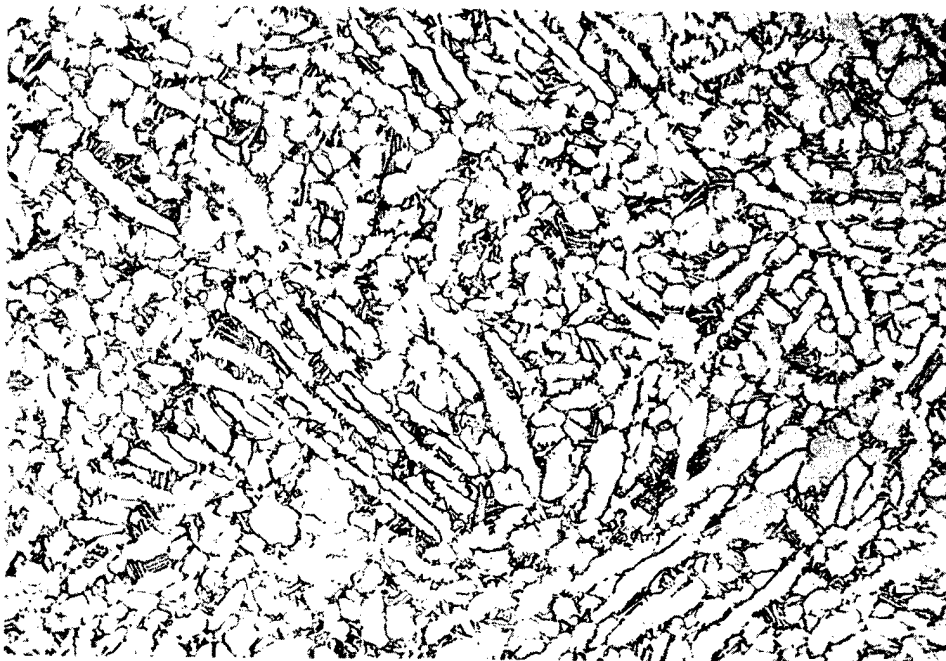
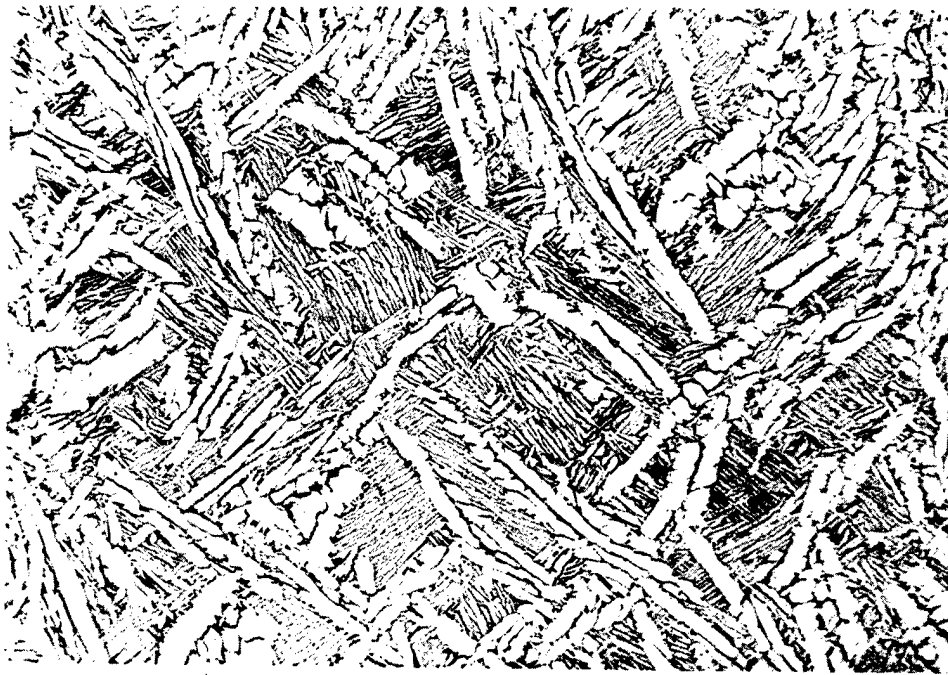
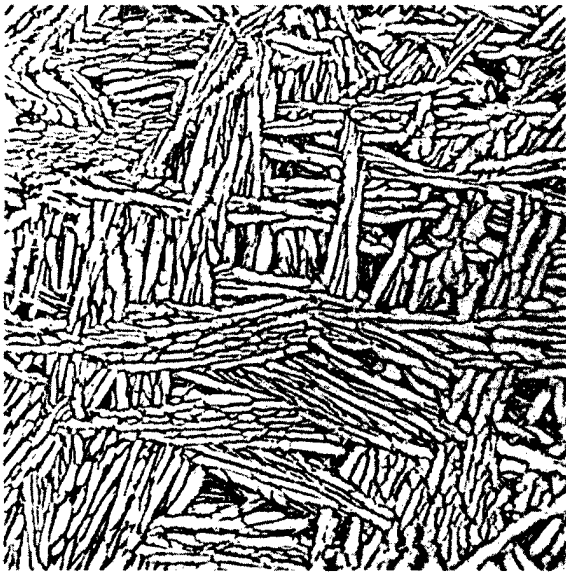

FIGURE 19 - SECTION CUT THROUGH HEAVY CENTER PORTION OF ALPHA-BETA FORGING TO SHOW GRAIN FLOW PATTERN. CIRCLED AREA IS LOCATION OF MICROSTRUCTURE SHOWN IN FIGURE 20.



200X

FIGURE 20 - MICROSTRUCTURE (LONGITUDINAL) IN UPPER FLANGE OF MACHINED FORGINGS (BETA FORGED) (UPPER PHOTO) AND (ALPHA-BETA FORGED) (LOWER PHOTO). TYPICAL LOCATIONS OF THESE SECTIONS ARE SHOWN IN FIGURES 16 AND 19 (CIRCLED AREAS).



LONGITUDINAL

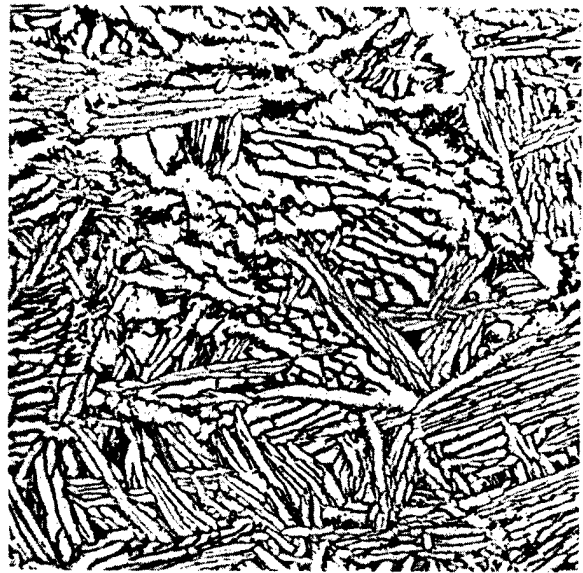

TRANSVERSE

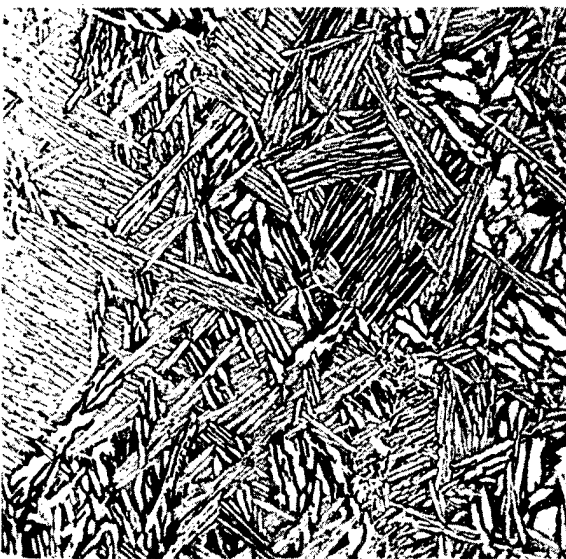

LONGITUDINAL



TRANSVERSE

200X

FIGURE 21 - MICROSTRUCTURES OF HEAVY CENTER SECTION (UPPER PHOTOS) AND FLANGE TRANSITION (LOWER PHOTOS) OF ROUGH FORGING (BETA FORGED). SEE FIGURE 16 FOR THE LOCATIONS OF THESE MICROSTRUCTURES.

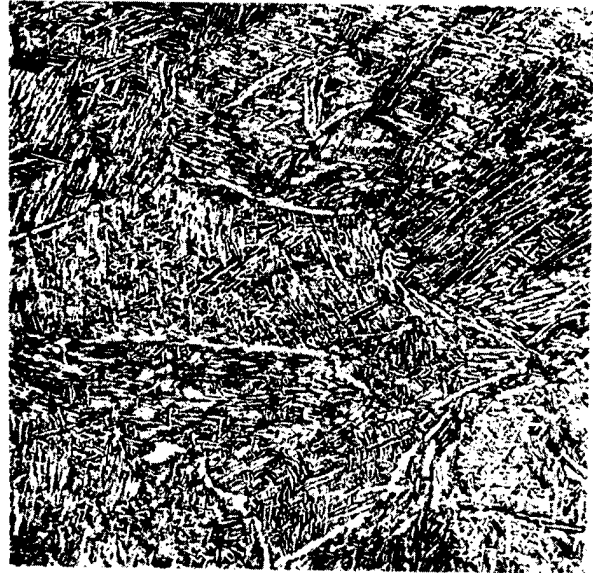
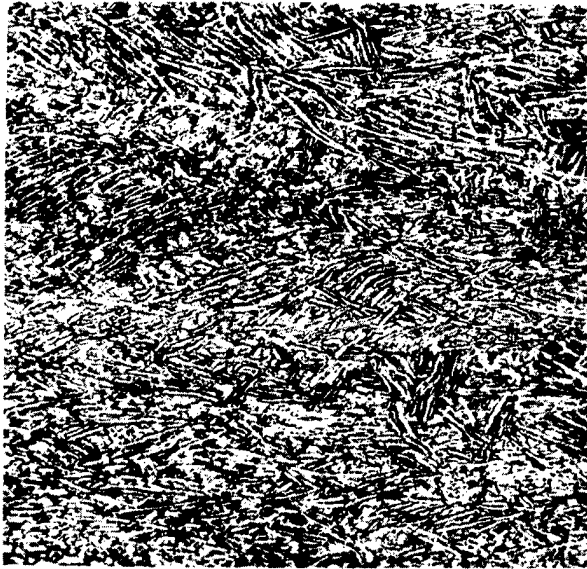

200X

FIGURE 22 - MICROSTRUCTURES IN FORGING (BETA FORGED) IN CENTER (UPPER LEFT) , SURFACE (UPPER RIGHT) AND FLASH (LOWER) IN OUTERMOST END TRANSVERSE SECTION (APPROXIMATELY ONE INCH FROM END OF ROUGH FORGING; DOTTED LINES AT LEFT END OF FIGURE 1)

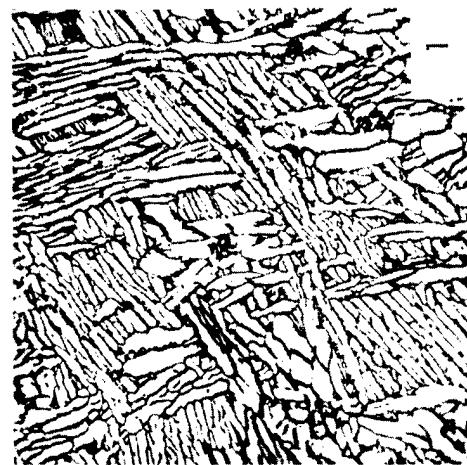
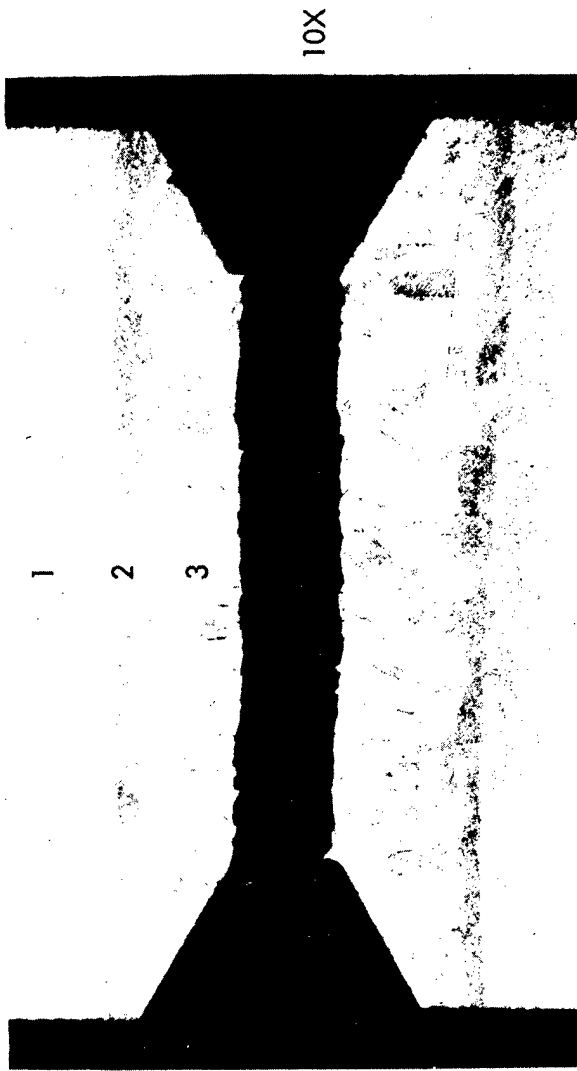

FIGURE 23 - ELECTRON BEAM WELDED NOTCHED TENSILE SPECIMEN (BETA FORGED) AFTER TESTING, SHOWING PROFILE OF FRACTURE (UPPER PHOTO) AND MICROSTRUCTURES (LOWER PHOTOS) OF THE THREE ZONES NOTED, (1) BASIS METAL, (2) HEAT AFFECTED ZONE, AND (3) WELD METAL.

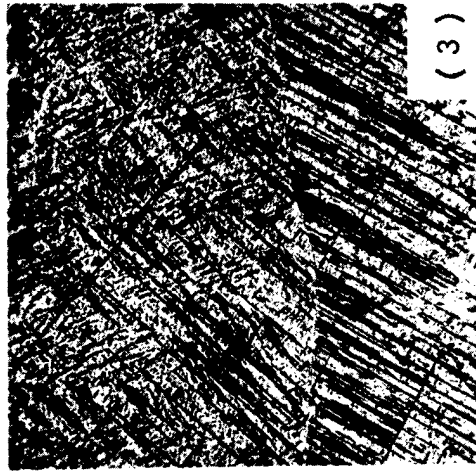
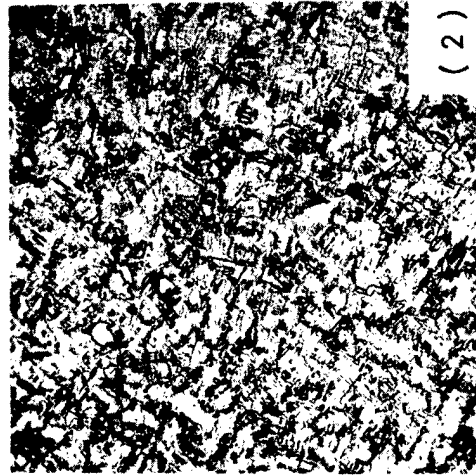
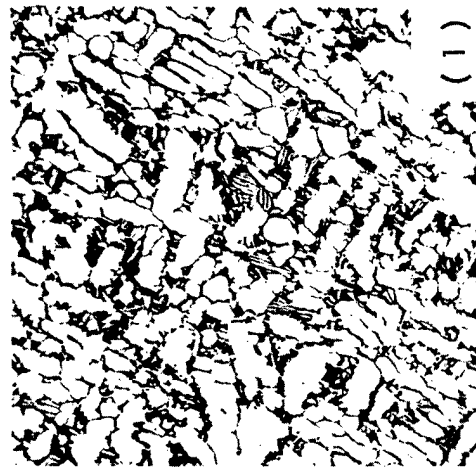
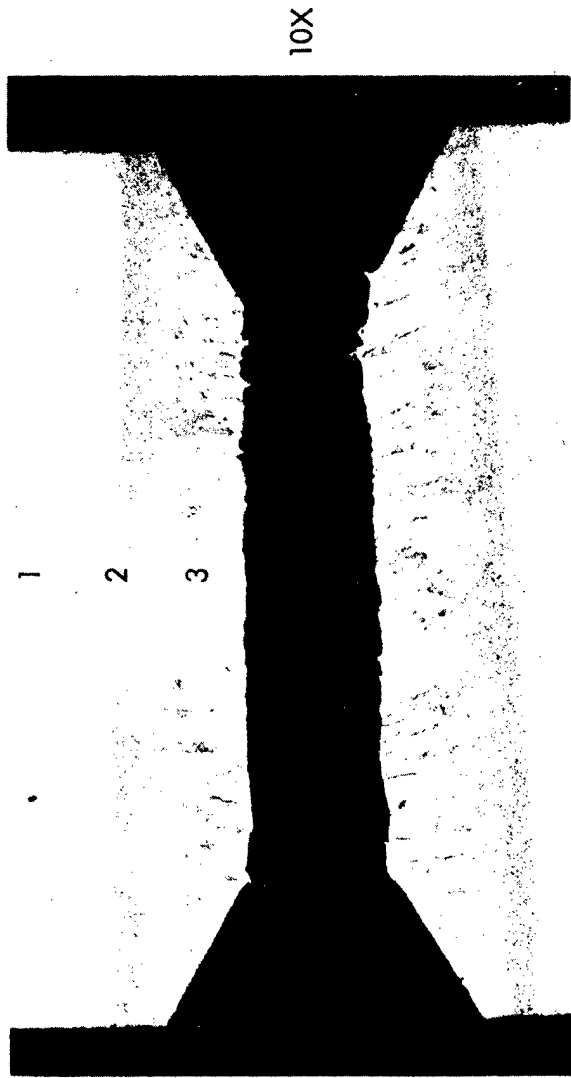
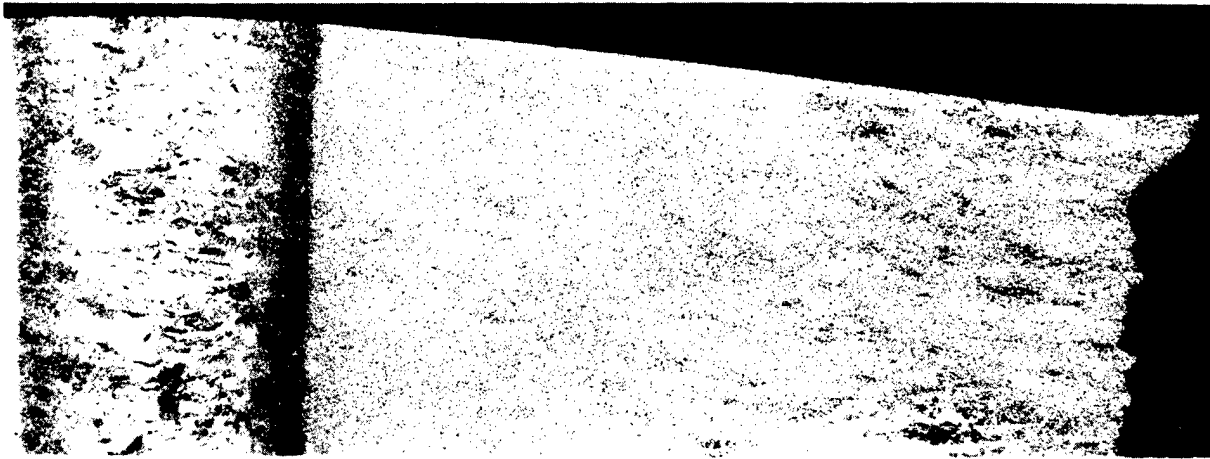
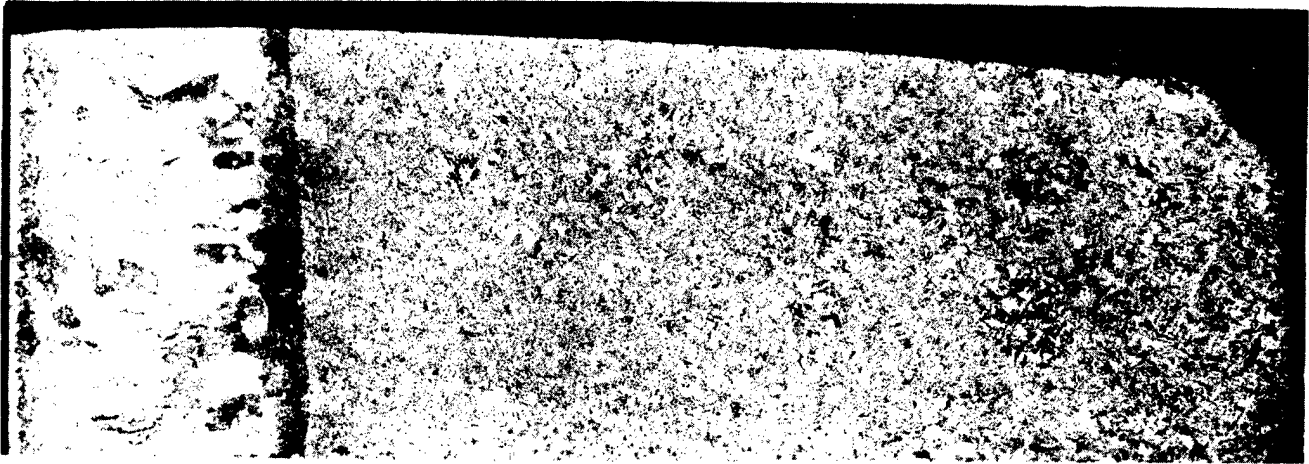

FIGURE 24 - ELECTRON BEAM WELDED NOTCHED TENSILE SPECIMEN (ALPHA-BETA FORGED) AFTER TESTING, SHOWING PROFILE OF FRACTURE (UPPER PHOTO) AND MICROSTRUCTURES (LOWER PHOTOS) OF THE THREE ZONES NOTED, (1) BASIS METAL, (2) HEAT AFFECTED ZONE, AND (3) WELD METAL.



10X

FIGURE 25 - ELECTRON BEAM WELDED SMOOTH TENSILE SPECIMENS (BETA FORGED) (UPPER PHOTO) AND (ALPHA-BETA FORGED) (LOWER PHOTO) SHOWING WELD (LEFT ENDS OF PHOTOS) AND FRACTURE SURFACE AWAY FROM WELD (RIGHT ENDS OF PHOTOS). ALL OF THESE SPECIMENS FAILED AWAY FROM THE WELD.