

NATIONAL ADVISORY COMMITTEE FOR AERONAUTICS

TECHNICAL NOTE 2360

EFFECT OF TAIL SURFACES ON THE BASE DRAG
OF A BODY OF REVOLUTION AT MACH
NUMBERS OF 1.5 AND 2.0

By J. Richard Spahr and Robert R. Dickey

Ames Aeronautical Laboratory
Moffett Field, Calif.



Washington
April 1951

20000816 091

AQ Mou-11-35 10

1
NATIONAL ADVISORY COMMITTEE FOR AERONAUTICS

TECHNICAL NOTE 2360

EFFECT OF TAIL SURFACES ON THE BASE DRAG
OF A BODY OF REVOLUTION AT MACH
NUMBERS OF 1.5 AND 2.0

By J. Richard Spahr and Robert R. Dickey

SUMMARY

Wind-tunnel tests were performed at Mach numbers of 1.5 and 2.0 to investigate the influence of tail surfaces on the base drag of a body of revolution without boattailing and having a turbulent boundary layer. The tail surfaces were of rectangular plan form of aspect ratio 2.33 and had a symmetrical, circular-arc airfoil section. The results of the investigation showed that the addition of these tail surfaces with the trailing edges at or near the body base incurred a large increase in the base-drag coefficient. For a cruciform tail having a 10-percent-thick airfoil section, this increase was about 70 percent at a Mach number of 1.5 and 35 percent at a Mach number of 2.0. As the trailing edge of the tail was moved forward or rearward of the base by about one tail-chord length, the base-drag increment was reduced to nearly zero. The increments in base-drag coefficient due to the presence of 10-percent-thick tail surfaces were generally twice those for 5-percent-thick surfaces. The base-drag increments due to the presence of a cruciform tail were less than twice those for a plane tail.

An estimate of the change in base pressure due to the tail surfaces was made, based on a simple superposition of the airfoil-pressure field onto the base-pressure field behind the body. A comparison of the results with the experimental values indicated that in most cases the trend in the variation of the base-drag increment with changes in tail position could be predicted by this approximate method but that the quantitative agreement at most tail locations was poor.

INTRODUCTION

The pressure acting on the base of a body of revolution flying at supersonic velocity is of considerable importance because the base drag can, in some cases, be more than half of the total drag. Numerous wind-tunnel and free-flight investigations have been performed to determine the magnitude of the base pressure at various supersonic Mach numbers. A comparison of the results of four independent

investigations with bodies of revolution without boattailing and with turbulent boundary layers (references 1, 2, 3, and 4) is shown in figure 1. The data from references 1 and 2 were obtained in wind tunnels, and those from references 3 and 4 were measured in free flight by means of firings in a ballistics range and of rocket launchings, respectively. Figure 1 shows that the base-pressure coefficients from references 1, 2, and 3 are in essential agreement, whereas the corresponding results from reference 4, for which tail surfaces were present on the body, are considerably more negative. On the basis of a uniform pressure measured over the base during the latter tests, it was concluded in reference 4 that such differences were not due to the presence of tail surfaces near the body base. Instead, it was suggested that these differences may be due to the small dynamic scale (R , 1 to 5 million) of most wind-tunnel data compared to that of reference 4 (R , 16 to 110 million), although the results of reference 4 showed no effect of Reynolds number on the base-pressure coefficient over the Reynolds number range tested. In reference 5, differences in base-pressure results between wind-tunnel and free-flight tests are attributed to the effects of the reflected model bow wave on the wind-tunnel measurements. However, the more recent results of reference 1 show that the results of that reference presented in figure 1 were independent of Reynolds number and were not affected by reflected shock waves. It appears therefore that the differences shown in figure 1 may be caused by the presence of tail surfaces. Since the trailing edges of the tail surfaces are located at the base of the body, and since the pressures near the trailing edge of the tail at zero angle of attack are less than the free-stream values, the interaction of this pressure field with the flow behind the base may result in a reduction of the base pressure and, hence, in an increase in the base drag.

The present investigation was undertaken to measure the effect of tail surfaces on the base pressure of a body of revolution in an attempt to resolve the differences between the base-pressure results indicated in figure 1. It was also the purpose of the investigation to determine the variation of the base pressure with axial location of the tail surfaces, number of tail surfaces, and airfoil thickness ratio.

NOTATION

c tail chord

C_{D_b} base-drag coefficient $\left(\frac{D_b}{q_0 S_b} \right)$

D_b base drag

l body length

M	Mach number
p	local airfoil static pressure
p_b	base pressure
p_o	free-stream static pressure
P	airfoil pressure coefficient $\left(\frac{p-p_o}{q_o} \right)$
P_b	base-pressure coefficient $\left(\frac{p_b-p_o}{q_o} \right)$
ΔP_b	change in base-pressure coefficient due to tail surfaces $\left(P_{b_{\text{tail on}}} - P_{b_{\text{tail off}}} \right)$
q_o	free-stream dynamic pressure
R	Reynolds number $\left(\frac{V_o l}{\nu} \right)$
S	dead-air-region surface area
S_b	base area
t	maximum tail thickness
V_o	free-stream velocity
x	distance of tail trailing edge forward of base (See fig. 2(a).)
ν	kinematic viscosity

APPARATUS

Wind Tunnel and Balance

The investigation was conducted in the Ames 1- by 3-foot supersonic wind tunnel No. 1. This wind tunnel is a closed-circuit, continuous-operation tunnel in which the Reynolds number can be varied by changing the absolute pressure in the tunnel from one-fifth of an atmosphere to approximately three atmospheres. A Mach number variation from 1.2 to 2.4 is obtained by adjusting the shape of the flexible steel plates which form the upper and lower walls of the nozzle. The tunnel

is equipped with a strain-gage type balance for measuring the aerodynamic forces on sting-supported models.

Model and Support

The general configuration and the dimensions of the model are shown in figure 2. The body consisted of a 10-caliber, tangent, ogival nose followed by a cylindrical afterbody 1.250 inches in diameter. The fineness ratio of the basic short-body configuration was 6.12. An additional cylindrical section was available for insertion between the ogival nose and the afterbody which increased the fineness ratio to 7.65.

The tail fins were of rectangular plan form and of symmetrical circular-arc airfoil section with maximum thickness ratios of 5 and 10 percent. The tail fins were removable, which permitted the model to be tested body alone or as a body-tail combination with either a plane (two-fin) or a cruciform (four-fin) tail. Longitudinal slots in the cylindrical section of the body permitted the tail fins to be moved fore and aft in increments of one-fifth the chord length. In the most forward position, the trailing edge of the tail was one chord length ahead of the body base, and in the most rearward position, the trailing edge of the tail was one chord length behind the body base.

The model was attached to the balance by means of a 1/2-inch-diameter, 5-inch-long support sting which was an integral part of the body. The ratio of the support to body diameter was 0.4 and the support length was four times the body diameter. This design was selected on the basis of the results of references 1 and 6 which indicate that, with this support configuration, the effects of support interference on the base pressure of the body are small. Figure 2(b) shows the model with cruciform tail installed in the wind tunnel. The plane-tail configuration was installed with the tail chord plane parallel to the short (1 ft) dimension of the wind tunnel.

Four 0.03-inch-diameter pressure orifices were located 1/32 inch behind the body base. These orifice holes were drilled radially into the sting at 45° from the planes of the tail fins and were connected to a common base-pressure line. A base-pressure survey rake of five 0.03-inch-diameter steel tubes was used during most of the test runs to investigate the uniformity of the pressure acting over the base. (See fig. 3.)

The results of reference 1 show that the base pressure can be affected by the intersection and resulting interaction with the dead-air region of the body-nose shock wave reflected from the tunnel walls. The effect on the base pressure is excessive if this intersection occurs at a point close to the base. For the short model length, which was used

in all the tests for which data are presented herein, the intersection with the dead-air region of the reflected bow wave at a Mach number of 1.5 occurred at approximately 2.6 diameters downstream of the base. According to the results of reference 1, this intersection is sufficiently far downstream that the base-pressure results presented should not be significantly affected.

TESTS

Tests at zero angle of attack were conducted with the body alone and with both plane- and cruciform-tail configurations mounted on the body at various longitudinal positions. The body-tail combinations were tested with both 5- and 10-percent-thick tail sections. In general, the configurations tested employed the short body (7.656 in. long) with a 1/4-inch-wide salt band placed on the ogival nose to insure local transition to a turbulent boundary layer. However, several runs were made with the long body (9.562 in. long) at $M=2.0$ (where no effects of shock-wave reflections exist) to determine whether or not the effect of the body-nose pressure field on the base-pressure was appreciable. Additional tests with the body nose smooth were made to investigate the effect of the type of boundary layer approaching the base.

Base-pressure measurements were made by means of the orifices in the sting at tunnel total pressures corresponding to a Reynolds number range of 0.5×10^6 to 4.5×10^6 at Mach numbers of 1.5 and 2.0. In addition to the pressure measured by the orifices in the sting support, the pressure distribution over one quadrant of the model base was measured by means of the pressure survey rake during most of the test runs in order to determine the variation in the pressure over the base area. The results of these pressure-distribution tests indicate that the average deviation from the mean base-pressure coefficient was ± 0.003 , which, as shown later, is equal to the uncertainty in the base-pressure measurements. All base-pressure coefficients have been corrected for the effect of axial static-pressure variation in the wind-tunnel stream.

Total-drag measurements were made at only the highest Reynolds number for Mach numbers of both 1.5 and 2.0.

The precision of the results presented for the base-pressure coefficient has been computed from the uncertainties in each of the measured quantities and in the corrections due to the pressure gradients in the wind-tunnel stream. It was found that the major error was due to the uncertainty with which the stream pressure gradient was known. Other sources of error, such as the errors due to the uncertainty in the readings of the manometer tubes were found to be negligible. It is estimated that the total uncertainty in the measured base-pressure coefficient is ± 0.003 .

ANALYSIS

The addition of tail surfaces near the base of a body results in a change in the pressures in this region on account of the airfoil thickness distribution. Since (as indicated in reference 1) the base pressure is largely the result of the local stream conditions in this region, such an addition would be expected to change the base pressure of the body. Although this base-pressure change is not subject to accurate analytical treatment because of the complex nature of the flow involved, calculations have been made on the basis of several simplifying assumptions in an effort to obtain an estimate of the order of magnitude of the effect of tail surfaces and their positions on the base pressure of a body of revolution.

The simplified flow field used for these calculations is shown in figure 4. From the results of reference 1, it is known that any disturbance which impinges on the dead-air region can affect the base pressure. Hence, for the present analysis, it was assumed that the base-pressure increment due to the tail surfaces is a function only of the airfoil pressure coefficients at the boundary of the dead-air region (see fig. 4). It was further assumed that the magnitude of this increment is equal to the integrated average over the surface of the dead-air region (shaded area of fig. 4) of these pressure coefficients. Since the airfoil pressure coefficient is zero in region (1), the base-pressure increment is given by the relationship

$$\Delta P_b = \frac{\int (2) P dS}{S(1) + S(2)}$$

where (1) and (2) refer to regions on the surface of the dead-air region identified in figure 4. The inclined lines emanating from the tail surface in figure 4 represent lines of constant pressure for an airfoil in uniform two-dimensional flow, and from this two-dimensional airfoil pressure field the local pressure coefficients P at each point in region (2) may be obtained for use in the foregoing equation. For the calculations performed in the present investigation, the second-order supersonic airfoil-section theory of reference 7 was used to determine the variation of pressure coefficient along the chord of the tail surface and hence the entire pressure field above and below the tail. For purposes of these calculations, dimensions of the dead-air region were obtained from schlieren photographs. It was found in all cases that the convergence of the dead-air region was negligible and that the length of this region was approximately equal to the base diameter. Thus, the representation of the dead-air region by a cylinder having a length of one base diameter is considered adequate in the application of the present simplified analysis. The base-pressure increments due to the cruciform tail were taken as twice the corresponding values for the plane tail, since any interaction effects between the vertical and horizontal-tail pressure fields are neglected.

The qualitative effects of such variables as tail position and Mach number on the base-pressure increment due to tail surfaces are apparent from a consideration of the sketch of figure 4. If the tail were moved well forward of the base, the flow field behind the base would be entirely free of the airfoil pressure field, that is, region (2) would not exist, and no effect of the tail surfaces on the base pressure would be expected. As the tail is moved rearward, an increasing portion of the flow behind the base of the body is subjected to the negative pressure field at the rear of the airfoil, resulting in a corresponding reduction in the base pressure. As the tail is moved farther rearward, the pressures in region (2) become increasingly positive and a positive base-pressure increment results. One effect of Mach number on the base-pressure increment due to tail surfaces may be visualized by considering the lines of constant airfoil pressure (shown in fig. 4) to be inclined farther rearward as the Mach number is increased. As a result of this increased inclination in the airfoil isobars, the base pressure is influenced by the tail surfaces at tail positions farther forward than at lower Mach numbers. In addition, the airfoil pressure coefficient at any chord location decreases with increasing Mach number. On the basis of this simplified analysis, the net effect of Mach number on the base-pressure increment due to the presence of the tail surfaces is the result of these two changes in the airfoil pressure field.

RESULTS AND DISCUSSION

The principal results of the investigation are presented in figures 5 and 6. Figure 5 shows the variation of base-pressure coefficient with Reynolds number for various selected tail locations. The measured and estimated increments in base-pressure coefficient resulting from the addition of plane and cruciform tails of two thickness ratios are given in figure 6 as a function of the tail position along the body axis. The experimental base-pressure increments given in figure 6 correspond to the maximum Reynolds number of the tests, 4.5 million. The drag coefficients C_{D_b} corresponding to the base-pressure coefficients

P_b presented in figures 5 and 6 can be obtained from the relationship

$$C_{D_b} = -P_b$$

which follows directly from the definition

$$D_b = (p_o - P_b) S_b$$

Effects of Reynolds Number

Previous experimental investigations (e.g., reference 1) have shown that the base pressure acting on a body depends upon the nature of the boundary layer approaching the base. For a laminar boundary layer, the base-pressure coefficient becomes more negative with increases in Reynolds number. Transition to turbulent flow is accompanied by a positive increment in the base-pressure coefficient. The base pressure then remains constant with further increases in the Reynolds number. The presence of tail surfaces on a body would be expected to induce at least partial transition of the boundary layer, if laminar. Consequently, the determination of the effect of tail surfaces on the base pressure requires a knowledge of the nature of the boundary layer approaching the base.

Limited tests of the model with smooth surfaces showed that the base pressure of the body alone decreased continuously with increasing Reynolds number, indicating a laminar boundary layer approaching the base. For the body in combination with the tail surfaces, the base-pressure coefficient was essentially independent of Reynolds number but was larger in absolute magnitude by about 0.03 than the corresponding values for roughness added near the nose of the body. From the indications of these results, it is believed that the tail surfaces induced partial transition of the body boundary layer, as expected.

The condition of most practical interest is one in which the flow approaching the base has a fully developed turbulent boundary layer. The results given in figure 5 show that with roughness added to the body near the nose to achieve this condition the base-pressure coefficient was essentially independent of Reynolds number above about 2 million for the body alone and in combination with the tail surfaces. This result is in agreement with the measurements of reference 1 which show very little variation of base pressure at Reynolds numbers between 2 and 16 million when different kinds of artificial roughness were used. Likewise, the data of references 4 and 7 show no effect of Reynolds number between 5 and 100 million. The comparison given in figure 7 shows that for the body alone the results of the present tests are in close agreement with previous results obtained at Reynolds numbers from about 2 to 16 million. On the basis of this comparison and of the results of figure 5, it appears that the base-pressure results of the present investigation may be applicable to bodies with turbulent boundary layers at Reynolds numbers greater than those tested. Results (not shown herein) obtained during this investigation with artificial roughness on the tail surfaces near the leading edge showed no effect on the base pressure at Reynolds numbers above 2 million.

Effects of Tail Location

The results presented in figure 6 show that the addition of tail surfaces to the body resulted in a base-pressure reduction (base-drag increase) over most of the range of tail positions tested. The decrease in base-pressure coefficient was small for the tail located well forward of the base but, for the normal tail position, $x/c \approx 0$, this change was nearly the maximum, amounting to about 70 percent at $M=1.5$ and 35 percent at $M=2.0$. As the tail surfaces were moved aft of this position, the base-pressure increment decreased to zero and became positive at the most rearward tail location. Thus, for the 10-percent-thick fins tested, a large body-base-drag reduction can be realized by the placement of tail fins ahead of or behind the normal tail location ($x/c \approx 0$).

The results of tests made at a Mach number of 2.0 with the cylindrical portion of the body extended about 1.6 diameters (long body) showed the same changes in base pressure at all tail locations as was shown for the original (short) body. This agreement indicates that the effect of the body-nose pressure field on the tail pressures and hence on the base pressure is negligible and that the results presented may be applied to bodies of revolution having larger fineness ratios.

A comparison of the results presented in figure 6 shows that a similar trend existed between the experimental results and the estimated variation in base-pressure increment with tail position. It appears that the qualitative effect of tail position on the base pressure and the order of magnitude of the maximum base-drag increase due to the addition of tail surfaces can be predicted by the approximate method used. However, it is evident that the method is inadequate for a quantitative evaluation of the effect of tail surfaces on base pressure, particularly with the tail located partially behind the body base.

The results shown in figure 6 indicate that for the present configuration the base-drag increase due to tail surfaces may be reduced or eliminated by the placement of the tail behind the body base. However, it might be expected that such an arrangement would be accompanied by an increase in the drag of the tail surfaces because of the increased tail area exposed to the air stream, and because a portion of the tail (principally near the trailing edge) is located in a reduced pressure field due to the expansion around the base of the body. The results of limited tests made to measure this effect showed that as the trailing edge of the tail was moved from the base to one chord length behind the base, the drag coefficient of the tail surfaces increased essentially linearly with tail position. For the 10-percent-thick cruciform tail, for example, the change in the tail drag coefficient (based on the body frontal area) corresponding to this movement was about 0.10 at $M=1.5$ and 0.08 at $M=2.0$. These results indicate that in terms of the total drag, the favorable effect of moving the tail from $x/c = 0$ to -1.0 is

partially offset by this tail-drag increase.

Effects of Airfoil Thickness

The results of figure 6 show that, except for the most rearward positions of the tail surfaces, the base-pressure increment for the 5-percent-thick surfaces was about half that for the 10-percent-thick surfaces. This result, which is in agreement with the simplified analytical result (fig. 6), is reasonable since the airfoil pressures are proportional to the local slopes of the surface which in turn are directly proportional to the maximum thickness ratio.

Effect of Number of Tail Surfaces

A comparison of the results for the plane tail with those of the cruciform tail (fig. 6) shows that, in general, the base-pressure increment was increased by increasing the number of tail surfaces. However, this increment was not directly proportional to the number of tail surfaces, as the base-pressure increment due to the cruciform tail in most cases was less than twice as much as that due to the plane tail. This result indicates that the influence of each tail surface on the base pressure cannot be considered independently, inasmuch as a significant interaction effect on the base pressure exists between the panels of a multiple-tail configuration. A comparison of these results with the estimated values shows that, in all cases, the maximum base-pressure decrements due to the plane tail are in close agreement with the estimated values; whereas the corresponding values are overestimated for the cruciform tail surfaces. This difference is presumably due to neglecting, in these calculations, any interaction between the pressure fields of the adjacent panels of a cruciform wing.

Effects of Mach Number

The results presented in figure 6 show that an increase in Mach number from 1.5 to 2.0 was accompanied by a general reduction in the magnitude of the base-pressure increment due to the tail surfaces and by a change in the variation of this increment with tail position. The former effect according to the simplified analysis is the result of the decrease in the absolute magnitude of the airfoil pressure coefficients with increasing Mach number, and the latter effect is attributable to the change in inclination of the lines of constant airfoil pressure as discussed previously.

A comparison of the results of the present investigation with those from previous tests is shown in figure 7 for the body without tail surfaces and with the cruciform tail located at $x/c = 0$. The body-tail configuration investigated in references 4 and 7 was essentially the same as that of the present tests. Figure 7 shows that the present base-pressure results are in essential agreement with previous results for the body alone at both Mach numbers investigated and for the body with tail surfaces at $M=2.0$. At $M=1.5$, however, the base-pressure coefficient measured in the present tests was more negative than the corresponding result from reference 4. Although the explanation for this difference at $M=1.5$ is not known, the results of the present investigation serve to indicate that the influence of tail surfaces on the base pressure is large enough to account for the discrepancy between previous base-pressure results for a body with tail surfaces (reference 4) and those for bodies without tail surfaces (references 1, 2, and 3).

Design Considerations

The foregoing results show that the presence of tail surfaces near the base of a body of revolution can result in a large increase in the base drag at supersonic speeds. In addition to the major factors investigated in these tests (tail location, airfoil thickness, number of tail surfaces, and Mach number), the magnitude of this base-drag increase is also expected to be a function of such design variables as the tail plan form, airfoil section, and the tail plan-form area relative to the base area. The introduction of sweep or taper into the tail plan form would tend to change the base-drag increment due to the tail surfaces as a result of the change in the pressure distribution near the tail root section. The base drag is a function of the tail airfoil section by virtue of the airfoil-thickness distribution and hence the pressure distribution. For a tail surface having the trailing edge near the base, airfoil sections having small trailing-edge angles, such as a double-wedge or a blunt-trailing-edge section, appear to be the most favorable since the pressure coefficients for these airfoils are small in the region of the body base.

The results given in figure 6 indicate that, in order to avoid or minimize the base-drag increase due to tail surfaces, the tail should be placed well ahead of or behind the base of the body. Movement of the tail forward, however, entails an increase in the tail area to maintain a given static margin. This increase in the tail area would result in an increase in the drag of the tail and hence would partially offset the reduction in base drag due to the forward movement of the tail surfaces. Movement of the tail surfaces behind the base incurs, in addition to an increase in tail drag, structural complications leading to a weight penalty. A possible method for circumventing these difficulties is the addition of a thin shell behind the base having the same diameter as the

body. With this body extension the tail surfaces could be far enough ahead of the base to eliminate any effect of the tail on the base drag. The small additional friction drag caused by the body extension would be partially or wholly compensated by the reduction in the tail area permitted by the rearward center-of-pressure shift due to the body extension.

CONCLUSIONS

Wind-tunnel tests were performed at Mach numbers of 1.5 and 2.0 to investigate the effect of tail surfaces on the base pressure of an unboattailed body of revolution having a turbulent boundary layer. The tail surfaces were of rectangular plan form and had a symmetrical circular-arc airfoil section. The results are compared with estimated values based on a simple superposition of the airfoil-pressure field onto the base-pressure field behind the body. The following conclusions have been drawn from the results of the investigation:

1. The addition of tail surfaces with the trailing edges near the base of the body resulted in a large increase in the base drag. For a cruciform tail having a 10-percent-thick airfoil section, this increase was about 70 percent at a Mach number of 1.5 and 35 percent at a Mach number of 2.0. As the tail was moved forward or aft of this location by about one tail-chord length, this base-drag increment was eliminated. With the tail leading edge located at the base of the body, the base drag was less than for the body alone. However, movement of the tail-surface trailing edges to positions behind the base resulted in an increase in the drag of the tail surfaces.
2. The estimated variation of the base-drag increment with axial tail location was similar to the experimental trend in most cases; however, the quantitative agreement with the experimental measurements generally was poor.
3. The increment in base drag due to the presence of tail surfaces was essentially independent of Reynolds number from a value of 2 million to 6 million based on the body length.
4. The base-drag increments due to the presence of 10-percent-thick tail surfaces were essentially twice those due to 5-percent-thick surfaces. The increments due to a cruciform tail were less than twice those due to a plane tail.
5. The maximum increase in base-drag coefficient due to the presence of the tail surfaces was reduced by an increase in Mach number.

Ames Aeronautical Laboratory,
National Advisory Committee for Aeronautics,
Moffett Field, Calif., March 7, 1951.

REFERENCES

1. Chapman, Dean R.: An Analysis of Base Pressure at Supersonic Velocities and Comparison With Experiment. NACA TN 2137, 1950.
2. Kurzweg, H. H.: New Experimental Investigations on Base Pressure in the NOL Supersonic Wind Tunnels at Mach Numbers 1.2 and 4.24. Naval Ord. Lab. Memo. 10113, Jan. 1950.
3. Charters, A. C., and Turetsky, R. A.: Determination of Base Pressure from Free-Flight Data. Aberdeen Ballistic Res. Lab. Rept. 653, March 1948.
4. Hill, Freeman K., and Alpher, Ralph A.: Base Pressures at Supersonic Velocities. Jour. Aero. Sci., vol. 16, no. 3, March 1949, pp. 153-160.
5. Faro, Ione D.: Experimental Determination of Base Pressure at Supersonic Velocities. Johns Hopkins Univ., Bumblebee Rept. 106, Nov. 1949.
6. Perkins, Edward W.: Experimental Investigation of the Effects of Support Interference on the Drag of Bodies of Revolution at a Mach Number of 1.5. NACA TN 2292, 1951.
7. Busemann, A., and Walchner, O.: Airfoil Characteristics at Supersonic Speeds. British R.T.P. Translation 1786. (Forschung. Vol. 4, no. 2, Mar./April 1933, pp. 87-92.)

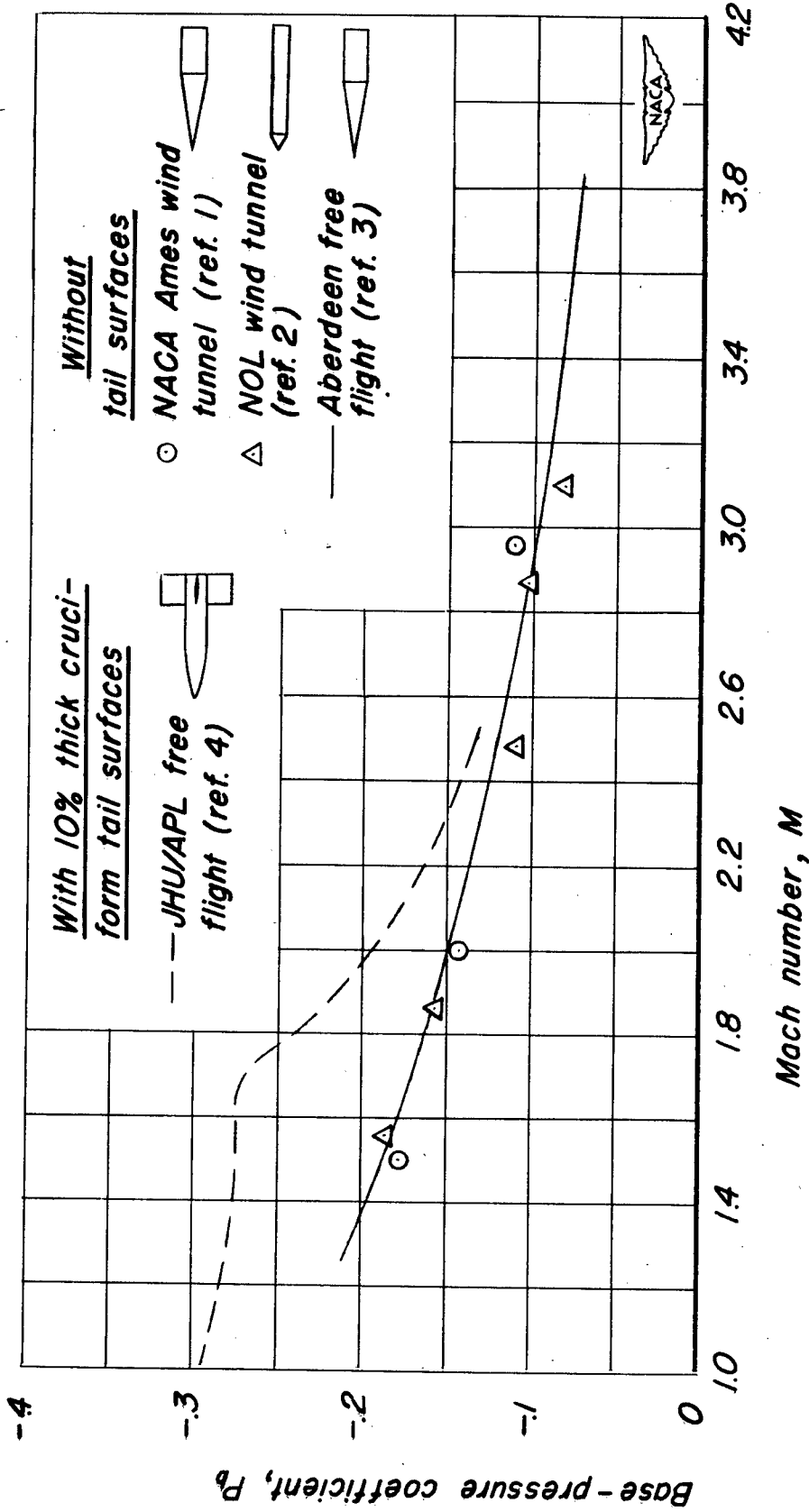
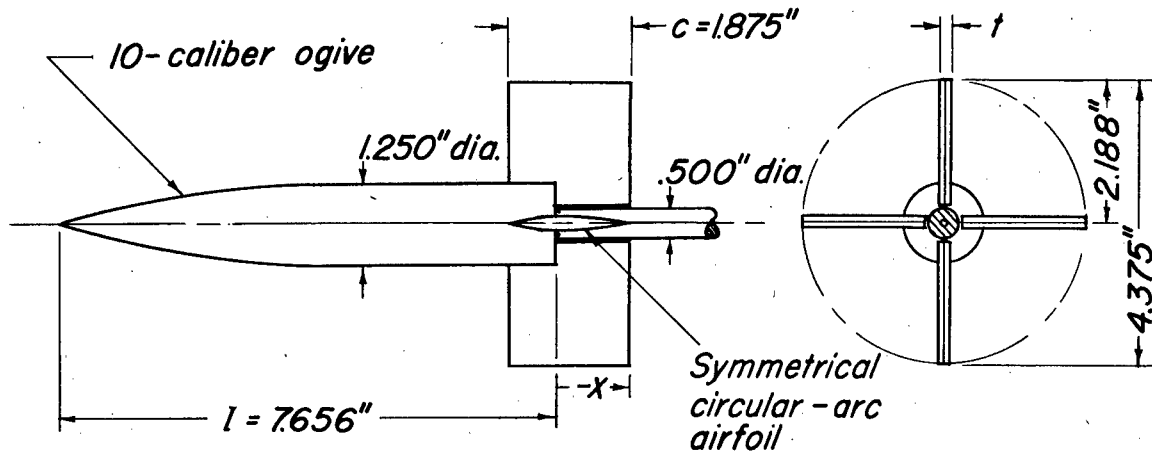
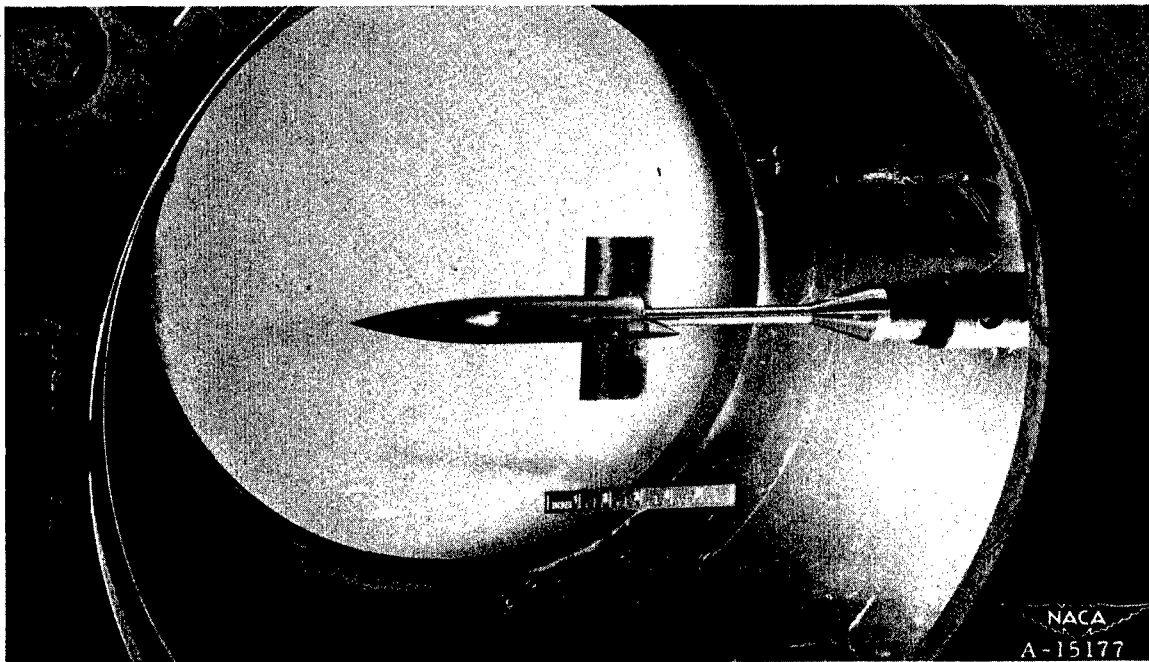

Figure 1.— Comparison of experimental base-pressure data for turbulent boundary-layer flow on bodies of revolution without boattailing.



(a) Model dimensions.



(b) Model installed in tunnel.

Figure 2.— Model and support.

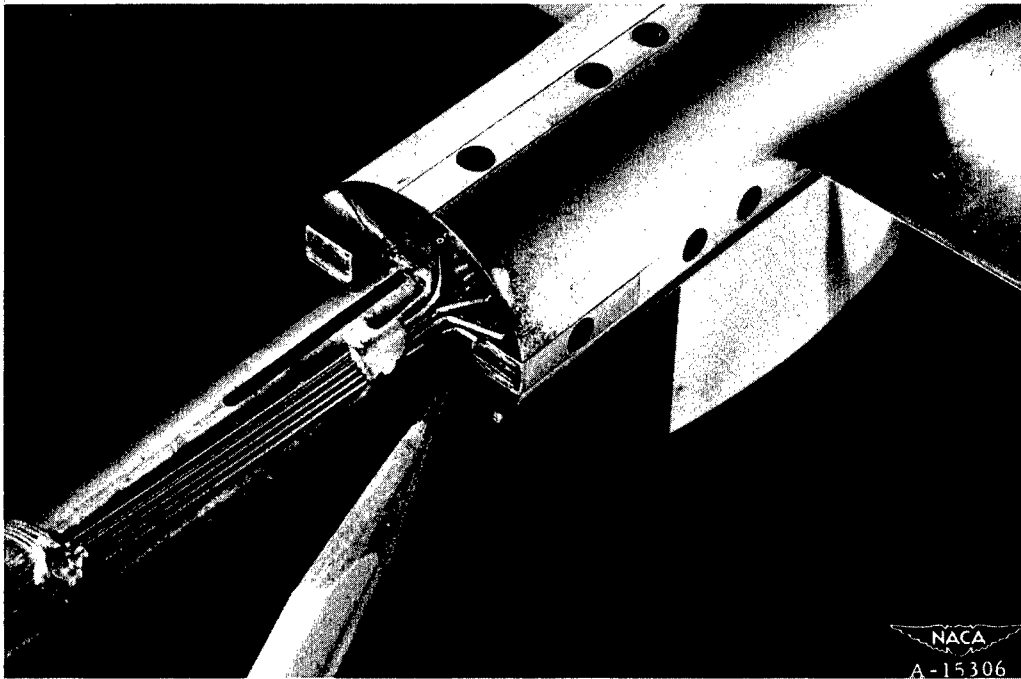

Figure 3.- Base-pressure survey-rake installation.

- 1 Region of uniform base pressure.*
- 2 Region of influence of tail surfaces on base pressure.*

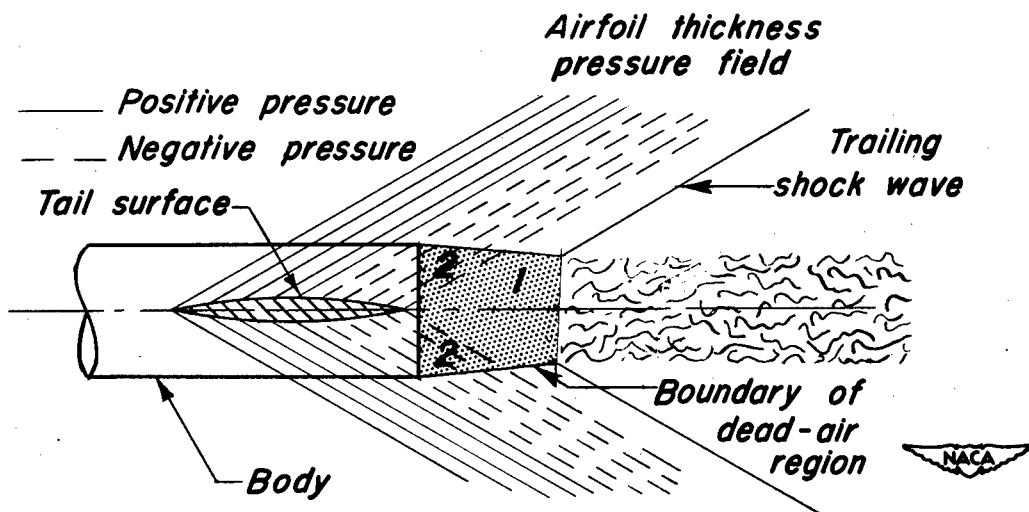
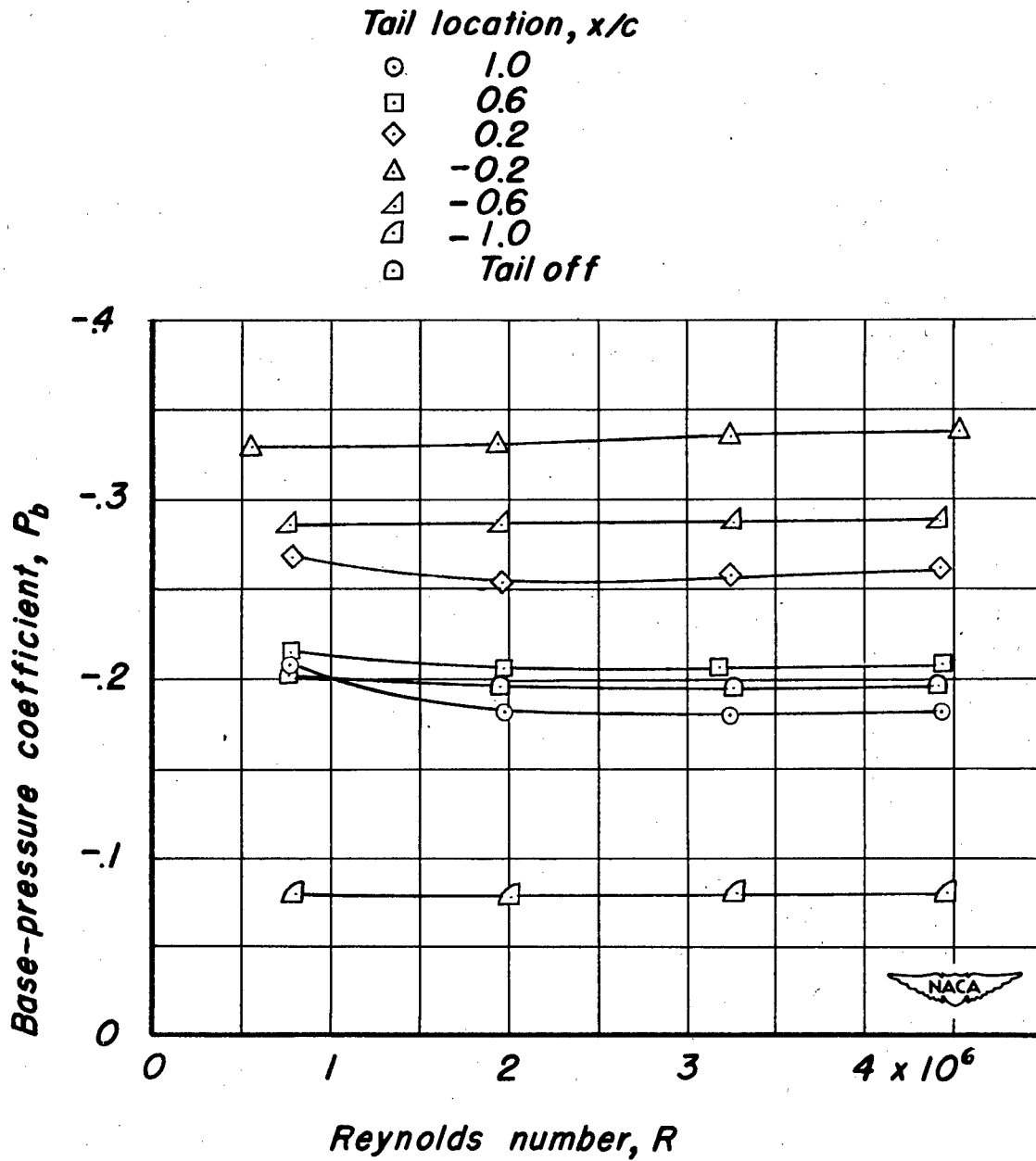
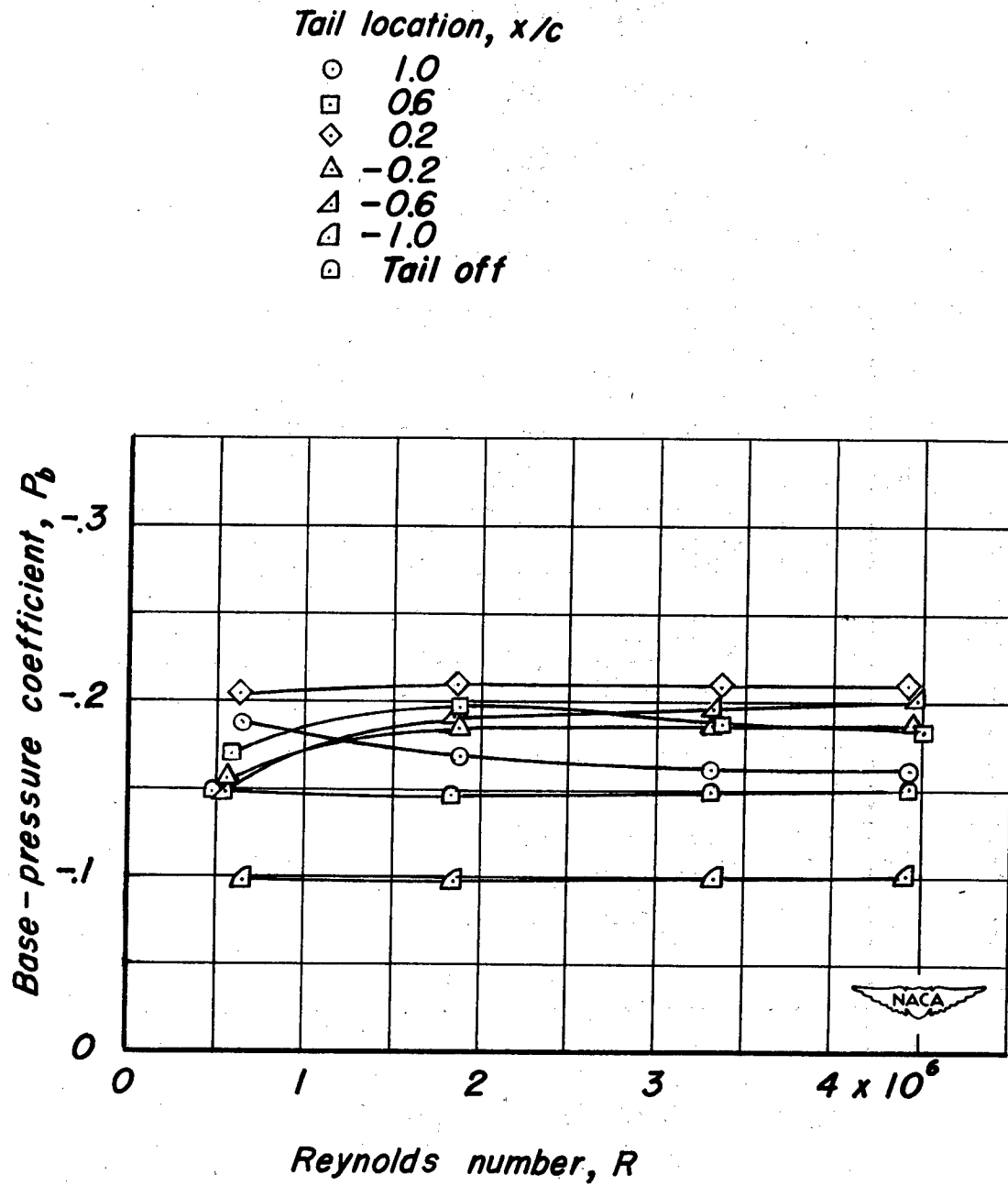

Figure 4.- Sketch of simplified flow field in the neighborhood of the base of a body-tail combination.



(a) $M = 1.5$

Figure 5.- Variation of base - pressure coefficient with Reynolds number; cruciform tail, $t/c = 0.10$, roughness added to body.



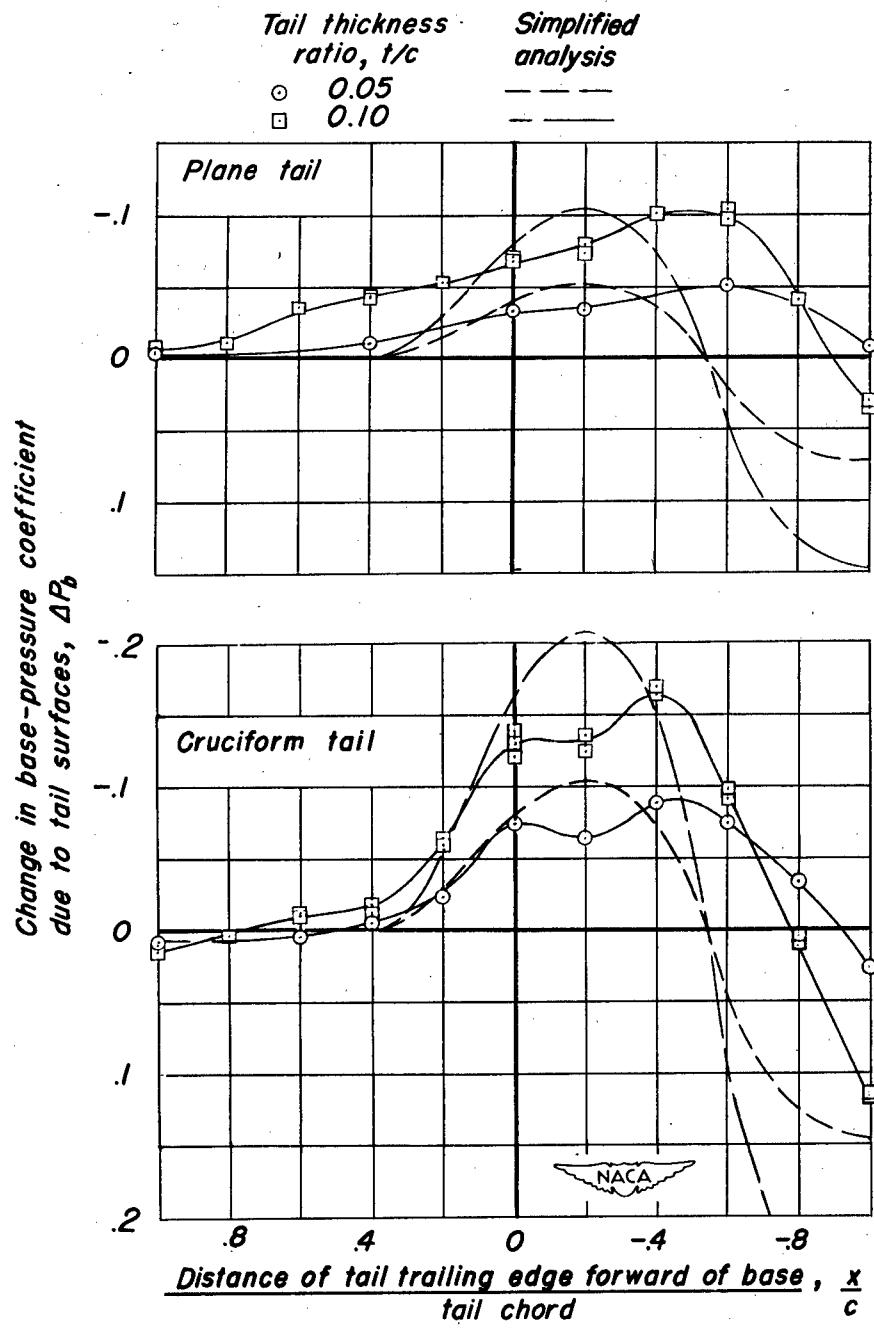

(a) $M=1.5$

Figure 6. - Change in base-pressure coefficient as a function of tail location.

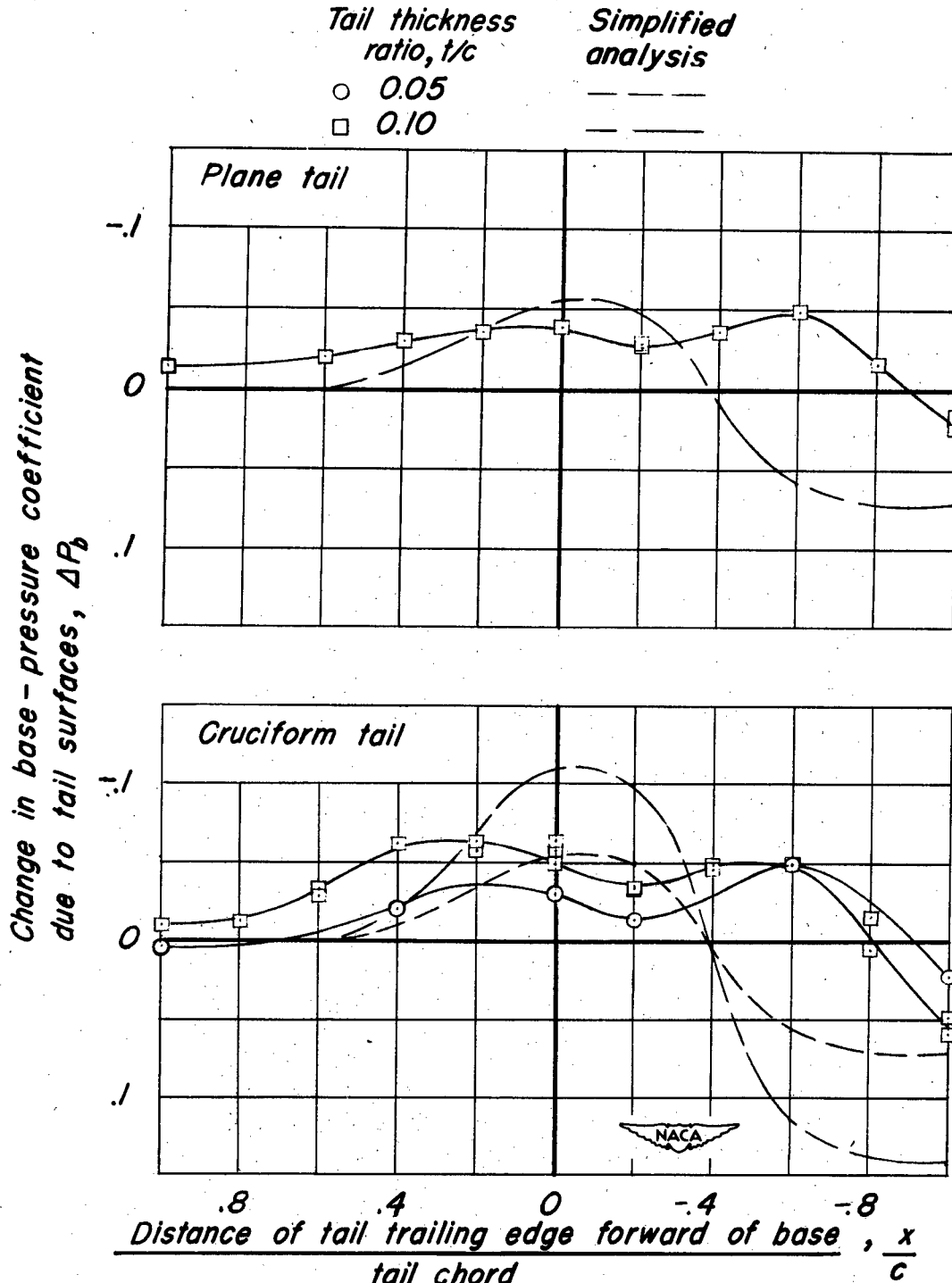

Figure 6. - Concluded.

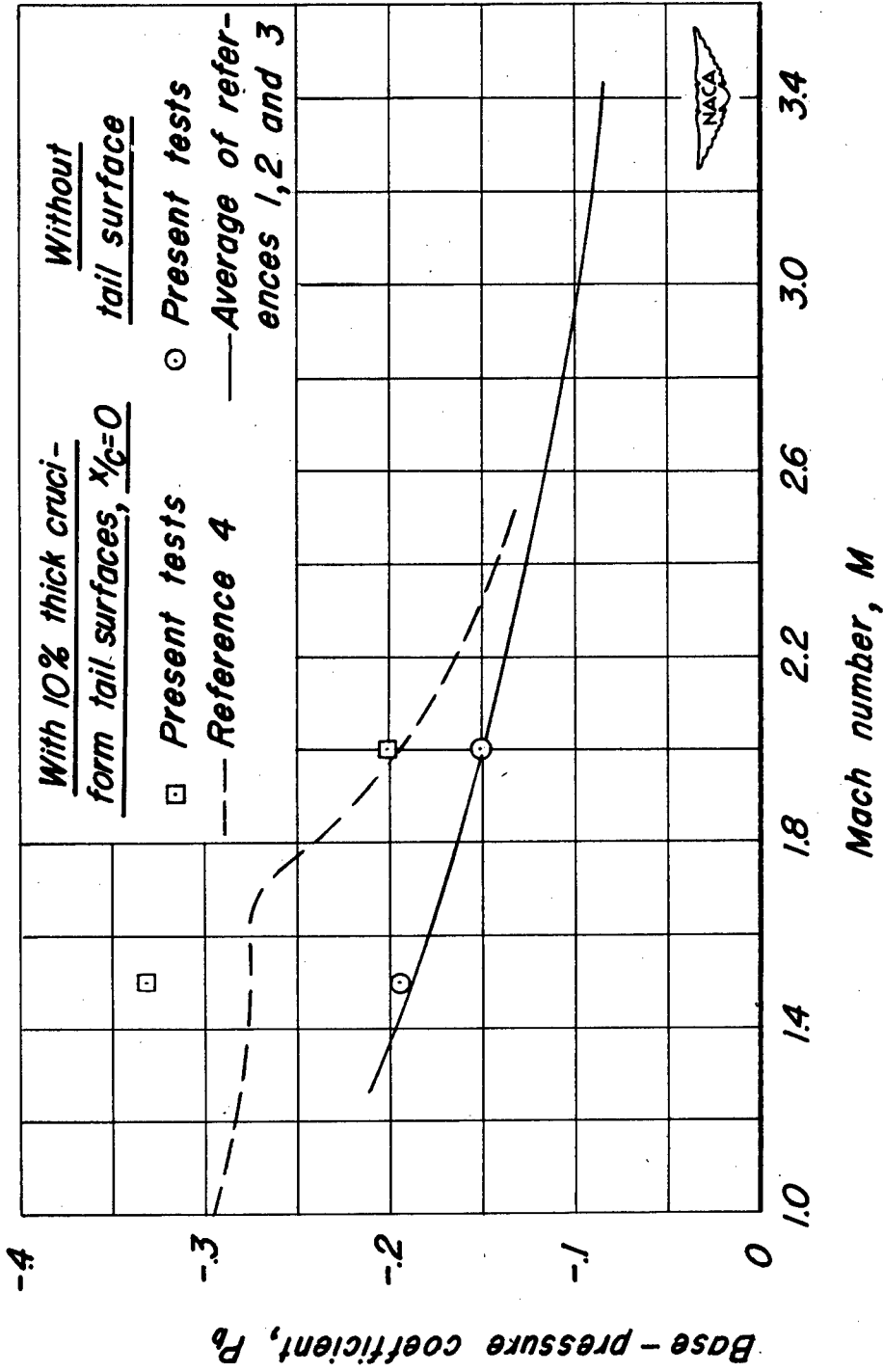

Figure 7.- Comparison of present base - pressure data with previous results.