

TID-4500, UC-35
Nuclear Explosions—
Peaceful Applications

Lawrence Radiation Laboratory
UNIVERSITY OF CALIFORNIA
LIVERMORE

UCRL-50489

**SIZE-DISTRIBUTION STUDY
OF PILEDRIVER PARTICLES**

David D. Rabb

October 1, 1968

DISTRIBUTION STATEMENT A
Approved for Public Release
Distribution Unlimited

20000908 179

**Reproduced From
Best Available Copy**

DIG QUALITY REPRODUCED 4

Contents

Abstract	1
Introduction	1
Drilling Program	2
Mining Program	4
Particle-Size-Distribution Study	7
Radioactivity-Distribution Study	12
Small-Scale Batch-Leaching Tests	15
Acknowledgments	17
References	17

SIZE-DISTRIBUTION STUDY OF PILEDRIVER PARTICLES

Abstract

Two samples of chimney rubble totalling over 5,000 lb were obtained during the post-shot exploration at Piledriver. These samples of broken granite underwent screen analysis, a radioactivity-distribution study, and cursory leaching tests to determine the solubility of specific nuclides.

The chimney was 160 ft in radius and 890 ft high. An injection of radioactive melt was encountered at 300 ft from shot point. Radiochemical analyses determined that the yield of the Piledriver nuclear device was 61 ± 10 kt.

The two samples were screened into 25 different size-fractions. An average

of the particle-size data from the samples showed that 17 percent of the material is between 20 mesh and 1 in.; 40 percent between 1 and 6 in.; and 30 percent between 6 in. and 3 ft. The amount of minus 100-mesh material is less than 1.5 percent.

The distribution of radioactivity in different particle size-fractions is inversely proportional to particle size. Small-scale batch-leaching tests showed that 25 percent of the radioactivity could be removed in a few hours by a film-percolation leach using distilled water; 40 percent if dilute acid were used.

Introduction

Because underground nuclear explosions result in material (broken rock) which may be subsequently mined by either conventional ore withdrawal or by in-place solution mining (in-situ leaching), the size distribution of the broken particles is of particular interest. Some important questions about size distribution that need to be answered are: What is the maximum size? What sizes constitute the bulk of the material? What is the percentage of fines? And, are there significant variations in size distribution between different materials or in different areas of the same material? Furthermore, what are the

amounts and species of radioactivity associated with each size-fraction at any one site?

The Piledriver Event (June 2, 1966) was a DOD underground nuclear explosion test in granite rock* at the Nevada Test Site (NTS). Piledriver was part of a study of the shock-hardening of underground structures. Depth of the burst was about 1500 ft, and yield was 61 ± 10 kt. The site is near the 5-kt Hardhat chimney, and

*The Climax granite stock in Area 15, NTS, North of Yucca Flat, is a well-defined and well-characterized medium, ideal for effects studies.

had been explored earlier by the Lawrence Radiation Laboratory, K-Division, to determine site characteristics. Because Piledriver had a much larger yield than Hardhat and was in the same medium, LRL proposed additional exploratory work to:

- define the chimney geometry and associated wall-rock conditions,
- determine the characteristics and distribution of rubble and radioactivity in the chimney,
- gain information pertinent to in-situ leaching, and
- secure a sample of melt for radiochemical analysis and yield determination.

The LRL program involved four phases:

- A drilling program from the surface to intercept the top of the chimney, obtain gas samples, and measure the volume of chimney voids.
- A mining program to measure the chimney radius, examine the wall rock near the chimney, and secure samples of chimney rubble for size-distribution and radioactivity studies.
- A leaching investigation to gain preliminary data on the leachability of material in/or near the chimney.
- If possible, acquisition of a sample of melt for a yield determination by radiochemistry.

Drilling Program

Immediately after Piledriver detonation, geophones recorded "noise" for only 14 sec; therefore, there was no certainty that there had been a collapse. However, reentry drilling from the surface in July 1967, lost circulation at a depth of 610 ft, where a 2-ft void was encountered.¹ Figure 1 shows an elevation view of the post-Piledriver drilling.

Pressurization tests in the hole above this point indicated very low permeability. At points below 610 ft, pressurization tests could not maintain pressures greater than 0.1 psig, inferring a very permeable condition. Drilling rates below 610 ft were 1 ft per min, or greater, with frequent evident voids and complete loss of drilling fluids. Subsequent TV camera runs and stereo pictures proved this void marked the top of the chimney, indicating a chimney height of 890 ft.

At 655 ft (total depth), the drill string was pulled up 30 ft to make a connection. When an attempt was made to resume drilling, the hole was caved. Since this condition could result in loss of drill stem and loss of the hole, it was advisable to suspend further drilling until after density, gamma, TV, and other hole-logging surveys could be performed, and a gas sample obtained. The maximum temperature recorded in the top of the chimney was 89°F. In an area where preshot ground temperature was about 75°F, gas samples indicated maximum beta and gamma radioactivity of 2 mR/hr. The measured volume of the void was about 1.3 million cubic ft (Ref. 1).

When penetrated, there was a slight negative pressure in the chimney due to high barometric pressure at the surface at that time. Later, during the exploratory

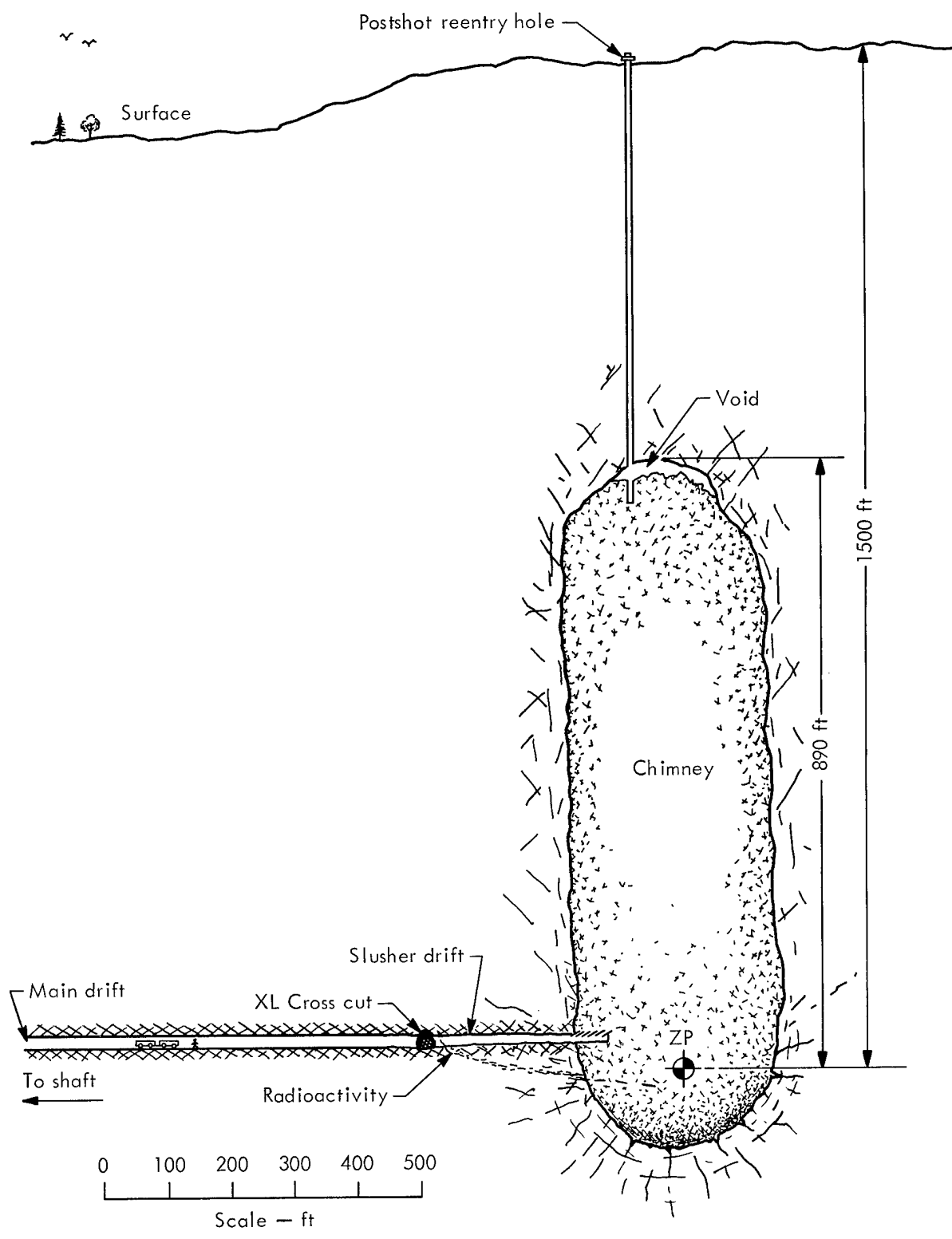

Fig. 1. Elevation view of post-Piledriver.

underground mining operations, air in the mine frequently became high in carbon dioxide (>10 percent) and low in oxygen (<16 percent), with traces of carbon monoxide. This condition seemed dependent upon surface barometric

pressure during long shutdowns (over weekends or because of NTS test activity). A 100-cfm exhaust fan, installed at the drill-hole collar, kept the cavity gas from bleeding into underground workings and alleviated this condition.

Mining Program

Based on previous experiences in granite at Hardhat and Shoal Events,^{2,3} the absence of an apical void and the relatively high chimney (890 vs 500 ft) at Piledriver were not expected. Because of these interesting anomalies, because data from Piledriver is applicable to Sloop (the proposed copperleach project in Arizona), and because a yield determination from a melt sample by means of radiochemistry was desired, the main drift used by the DOD for postshot exploration was extended toward the chimney. This effort started in September 1967, and terminated in October of that year.

The DOD postshot exploration during February through August 1967 reopened the main drift to the so-called XL crosscut, 100 ft above and 312 ft from the center line over zero point* (see Fig. 1). Upon driving the drift approximately 20 ft beyond the XL crosscut to a point about 300 ft from the ZP, a thin vein of radioactive glass slag was encountered in a fissure between the top of the sand stemming and the granite back of the tunnel (Fig. 2). Maximum beta and gamma radiation readings were about 600 mR on contact.

*Zero point (ZP), or detonation point, is the center of emplacement of the explosive.

Chemical analysis by Los Alamos Scientific Laboratory (LASL) of a sample of this glass indicated the yield was about as expected, 61 ± 10 kt. Because there was a 14-month interim between shot date and analyses, the reported yield has a relatively wide range of uncertainty. However, LRL estimates, based on seismic data at shot time, implied a yield of about 68 kt (Ref. 4).

To isolate this contaminated area, a slusher drift was started in the left rib



Fig. 2. Radioactive slag near Piledriver chimney.

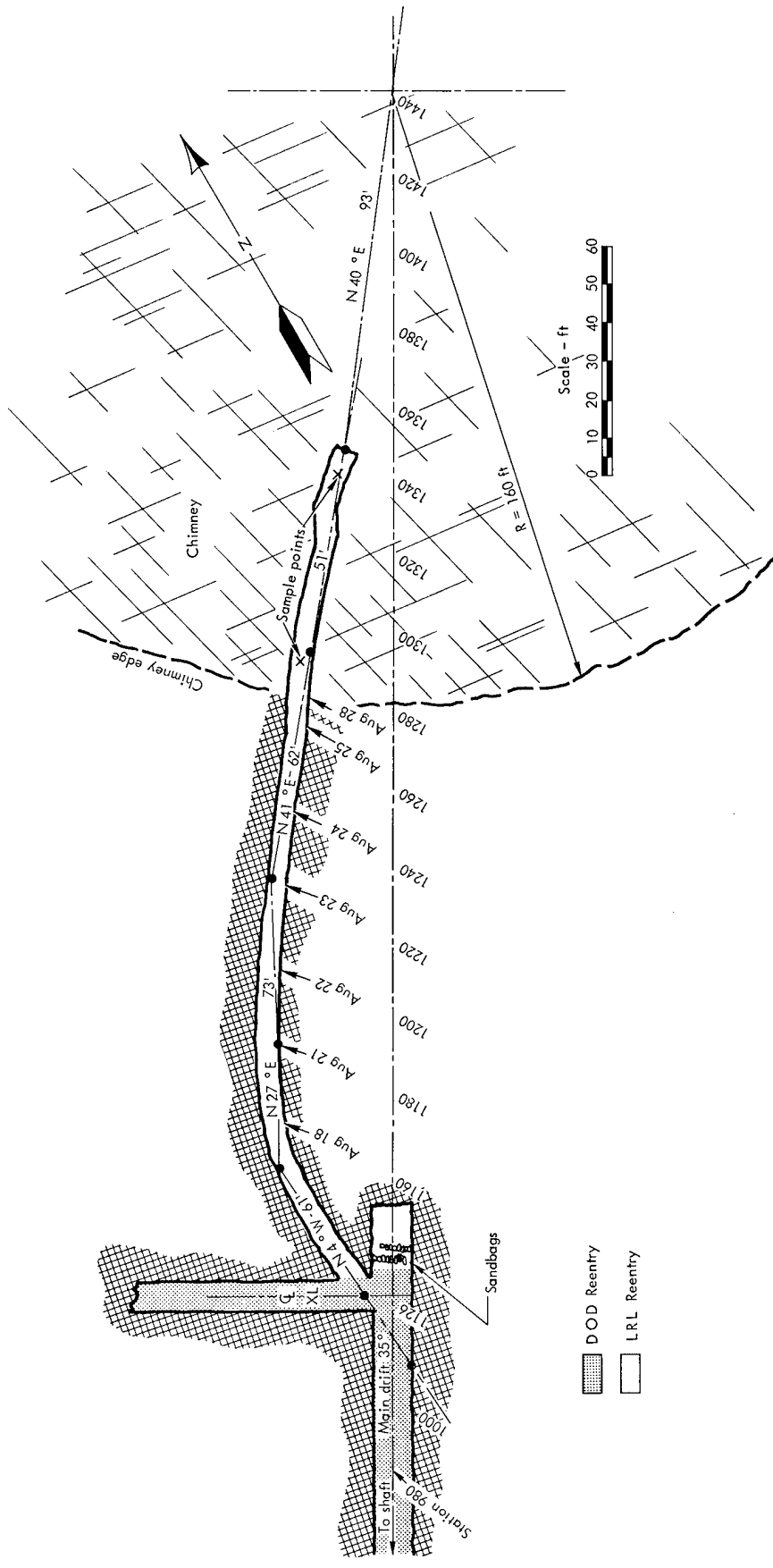

Fig. 3. Plan view of Piledriver reentry.

to bypass the hot area (Figs. 3 and 4). This drift angled roughly off the main drift near the XL crosscut (Station 1140) for 40 ft, and then paralleled the former main drift. Muck from slusher drift read about 3 mR on contact. This activity may have been gaseous krypton 85 and radon 222 because the activity decreased rapidly to about 1/2 mR within a few hours after removal to open air.⁵

When the slusher drift was about 140 ft in, the edge of the chimney (Fig.5) was encountered at Station 1280; therefore, the apparent chimney radius at this point (about 103 ft above ZP) was 160 ft.

This agrees with the predicted cavity radius of 146 ft because chimney radii of contained nuclear explosions have been found to average about 9 percent greater than the radii of the initial cavities.⁶ Figure 5 shows that the relatively solid rock outside of the chimney is clearly discernible, while the broken rubble inside the chimney is equally evident.

Further penetration into the chimney reached Station 1347, 67 ft inside the chimney, when work was discontinued because available funds ran out. Total length of the slusher drift was 207 ft.

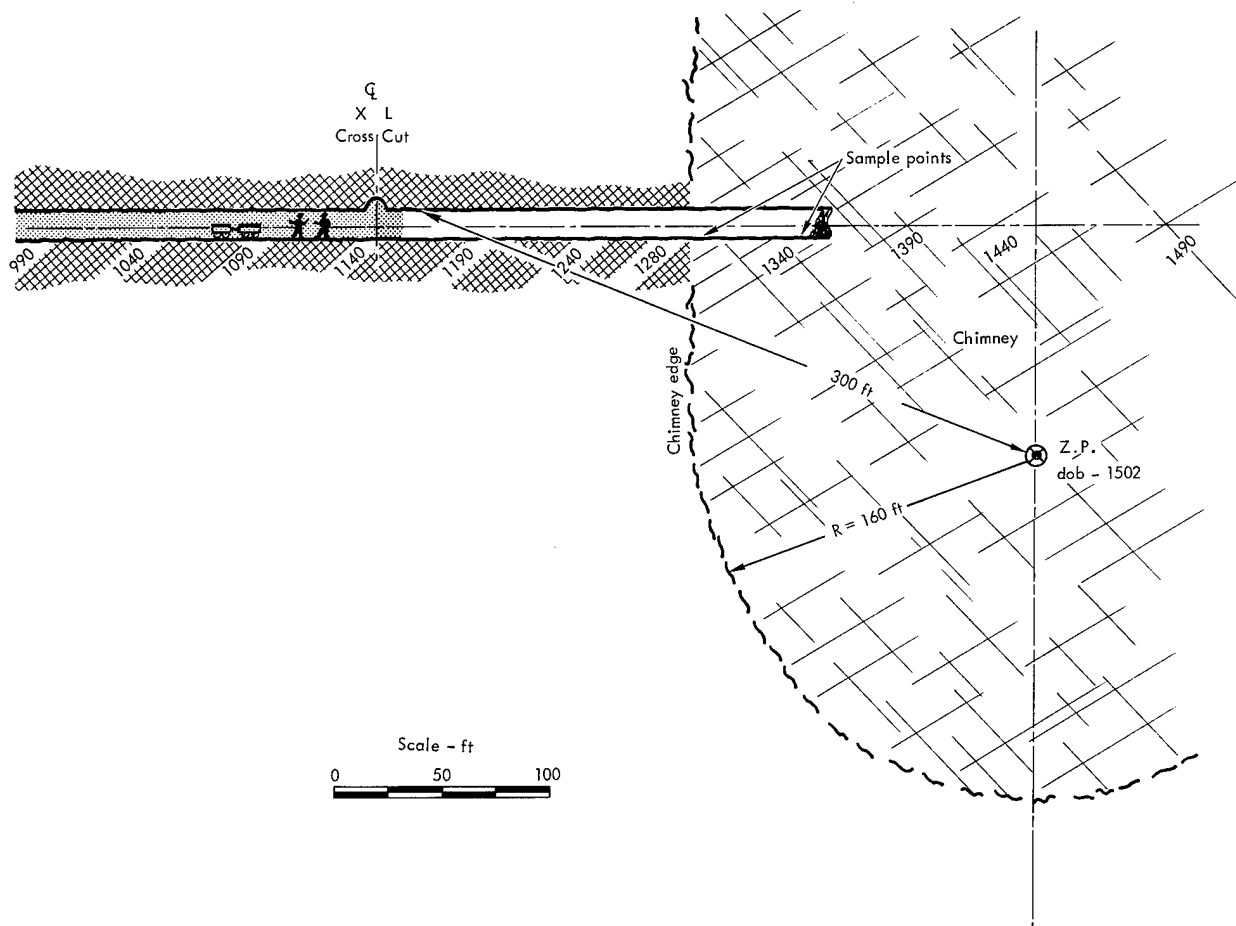

Fig. 4. Elevation view of Piledriver reentry.

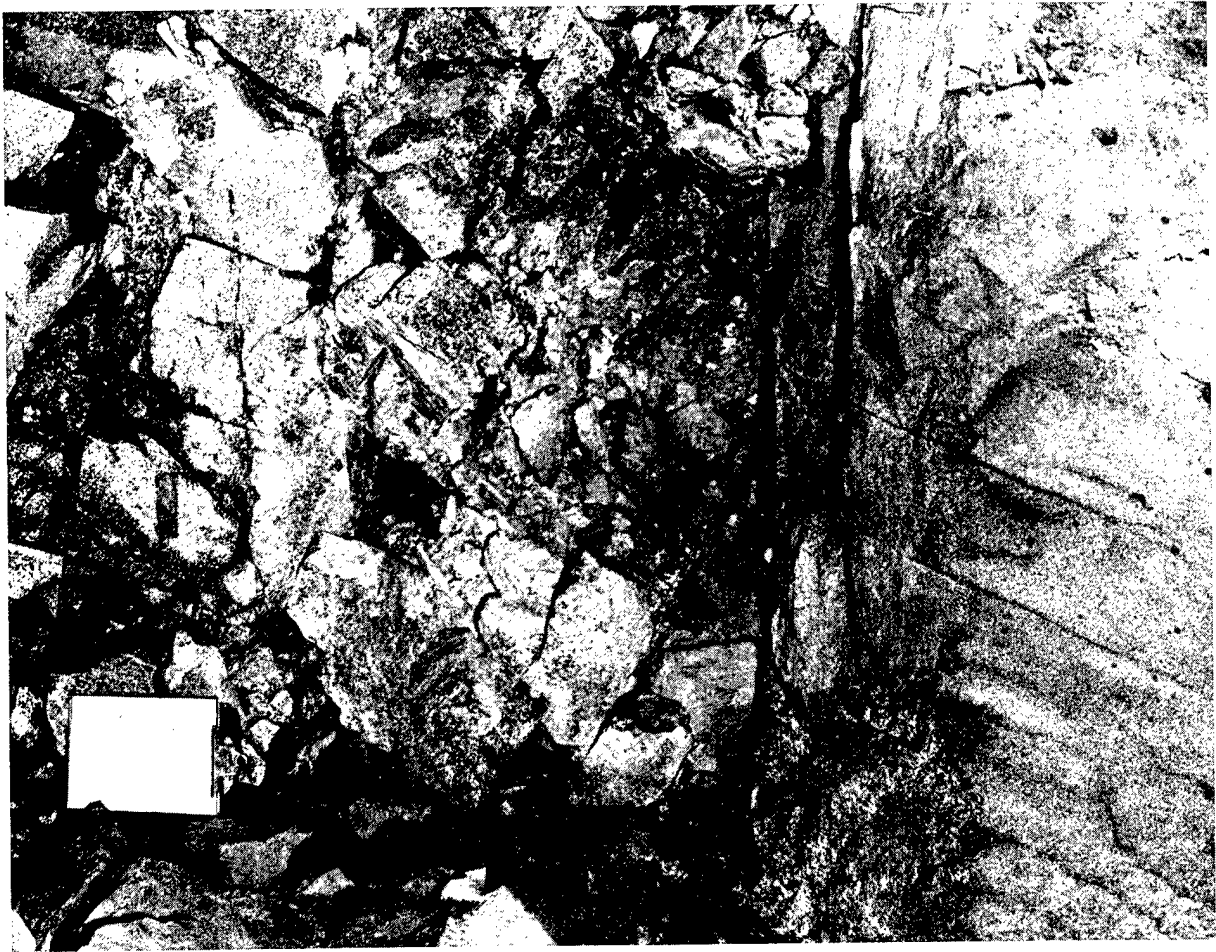

Fig. 5. Piledriver chimney edge.

Particle-Size-Distribution Study

To determine the distribution of the particle sizes in the rubble, two representative samples of the broken granite (or chimney rubble) were secured: Sample I from a point 10 ft into the chimney at Station 1290; Sample II from 60 ft in at Station 1340. Sample weights were 1387.5 and 3350.75 lb, respectively. Sample II was noticeably coarser than Sample I. In addition, two 300- to 500-lb boulders were recovered at the point of Sample II.

At the U. S. Bureau of Mines (BuMines) Station, Salt Lake City, Utah, the two

samples were separated into the six particle-size fractions listed in Table I, and weighed. Note that Sample I had no material in the plus 3-ft fraction. Later, the samples were each separated further into the size-fractions listed in Table II.

Using U. S. standard screens, all screening was done on dry material, either with a conventional vibrating screen base or a rotap* depending on the sieve size. All screens or sieves were run for

* An automatic shaking mechanism to aid in screen analysis.

Table I. Particle-size distribution of Piledriver chimney rubble samples.

Particle size		Max particle size (in.)	Weight percent ^a								
Minus	Plus		% of total			Cumulative %					
			I	II	Av	I	II	Av	I	II	Av
-	3 ft	about 60	-	7	3	0	7	3	-	100	100
3 ft	6 in.	36	25	43	34	25	50	38	100	93	96
6 in.	1 in.	6	47	36	42	71	87	80	75	50	63
1 in.	1/4 in.	1	17	6	12	89	93	92	28	14	21
1/4 in.	20 mesh	0.25	7	4	5	96	96	96	11	8	9
20 mesh	-	0.0331	4	4	4	100	100	100	4	4	4
			100	100	100						

^aTo nearest significant figure.

Table II. Detailed Particle-Size distribution and radioactivity distribution of Piledriver chimney rubble samples.

Sample		Nominal sieve opening (in.)	Weight percent ^a									Radioactivity ^a								
Particle size ASTM-U.S. std. sieve series	Plus		% of total			Cumulative %						1000's of counts/min/gm			% of total			Cumulative %		
			I	II	Av	I	II	Av	I	II	Av	I	II	Av	I	II	Av			
-	3 ft	boulder	-	7	3	-	7	3	-	100	100	-	0.3	-	3	1	-	100	100	
-	6 in.	36	25	43	34	25	50	38	100	93	96	0.3	0.2	3	12	8	100	97	99	
6 in.	3 in.	6.0000	21	20	20	46	70	58	75	50	63	0.5	0.3	3	8	5	97	85	91	
3 in.	2 in.	3.0000	13	9	11	57	79	69	54	31	42	1.0	0.5	4	6	5	94	78	86	
2 in.	1 in.	2.0000	13	8	11	71	87	80	42	22	32	2.0	0.8	9	8	8	90	72	81	
1 in.	1/2 in.	1.0000	13	4	9	84	91	89	28	14	21	4.0	1.1	18	6	12	81	64	73	
1/2 in.	1/4 in.	0.4950	5	2	3	89	93	92	15	11	13	6.0	1.3	9	3	6	63	58	60	
1/4 in.	4 mesh	0.2450	0.4	0.1	0.2	89	93	92	11	8	9	7.0	1.6	0.1 negligible	negligible	negligible	54	55	55	
4 mesh	6 mesh	0.1870	1.9	0.6	1.2	91	94	93	10	7	8	9.1	2.2	6	2	4	54	55	55	
6	8	0.1320	1.4	0.7	1.0	93	94	94	8	7	7	8.2	2.4	4	2	3	48	53	51	
8	12	0.0937	1.1	0.5	0.8	94	95	95	7	6	6	10.0	3.1	4	2	3	44	51	48	
12	16	0.0661	1.1	0.6	0.9	95	95	96	6	6	6	10.4	3.6	4	3	3	41	49	45	
16	20	0.0469	0.7	0.6	0.7	96	96	96	5	5	5	14.5	4.2	4	3	3	37	46	42	
20	30	0.0331	0.8	0.8	0.8	97	97	97	4	4	4	16.5	4.9	4	5	5	33	43	38	
30	40	0.0234	0.7	0.7	0.7	97	97	97	3	4	3	18.5	5.8	5	5	5	29	38	34	
40	50	0.0165	0.4	0.5	0.4	98	98	98	3	3	3	19.8	6.0	3	4	3	24	33	29	
50	60	0.117	0.4	0.3	0.4	98	98	98	2	3	2	21.3	7.1	3	3	3	21	30	26	
60	80	0.0098	0.4	0.5	0.5	99	98	98	2	3	2	22.8	7.1	3	5	4	19	27	23	
80	100	0.0070	0.2	0.2	0.2	99	99	99	1.4	1.8	1.6	23.3	6.8	1	2	2	16	22	19	
100	140	0.0059	0.3	0.4	0.3	99	99	99	1.2	1.5	1.4	25.9	7.5	3	4	3	14	21	17	
140	170	0.0041	0.1	0.2	0.2	99	99	99	0.9	1.1	1.0	29.4	8.2	1	2	2	12	17	14	
170	200	0.0035	0.2	0.3	0.2	99	100	99	0.8	1.0	0.9	30.4	9.5	2	3	2	10	15	12	
200	270	0.0029	0.2	0.4	0.3	100	100	100	0.6	0.8	0.7	36.2	10.9	3	5	4	9	11	10	
270	325	0.0021	0.1	0.1	0.1	100	100	100	0.4	0.4	0.4	38.5	11.8	1	2	2	6	6	6	
325	-	0.0017	0.3	0.3	0.3	100	100	100	0.3	0.3	0.3	50.1	12.8	5	4	5	5	4	5	

^aTo nearest significant figure.

15 min to ensure clean, complete separation of the size-fractions.

From the two tables, it is evident that only about 25 percent of Sample I is larger than 6 in., and 50 percent for Sample II,

with few (if any) boulders of greater than 3 ft in either sample. On the average, about 17 percent of the material is between 20 mesh and 1 in.; about 40 percent between 1 and 6 in.; and about 30 percent

between 6 in. and 3 ft—or, roughly 90 percent is in a size range which is amenable to "heap leaching." Another important point to a possible leaching operation is the relatively small amount of fines; less than 2 percent of minus 100 -mesh material for either sample.

Figure 6 shows the results of plotting, on a semi-log scale, the amount of material for each size-fraction (weight percentage) against the maximum particle size (nominal sieve opening). A log-normal distribution dictates there should be a fairly straight line, but this is not the case. There is a distinct break in the curve for Sample II for particle sizes between 2 to 3 in. From this fact, it is believed there is a tendency for the rock to break into pieces at about a 2- to 3-in. dimension, as though this were a

natural fracture spacing. Only Sample II shows this phenomenon. Sample I was taken from an area in the granite stock that was in a shear zone which was completely broken up and possessed no dominant fracture pattern. Extension of the two curves confirmed the observation that about 24 in. is the maximum size in the area of Sample I, and 50 in. in the area of Sample II.

The influence of grain size of the mineral particles in the rock is shown by the breaks in the slope of the curve at about 4 and 20 mesh. This becomes more evident if the vertical scale is expanded as in Fig. 7. The slight break in the curve at about 110 mesh is believed to be the separation point of the natural slimes from the sand formed during the detonation.

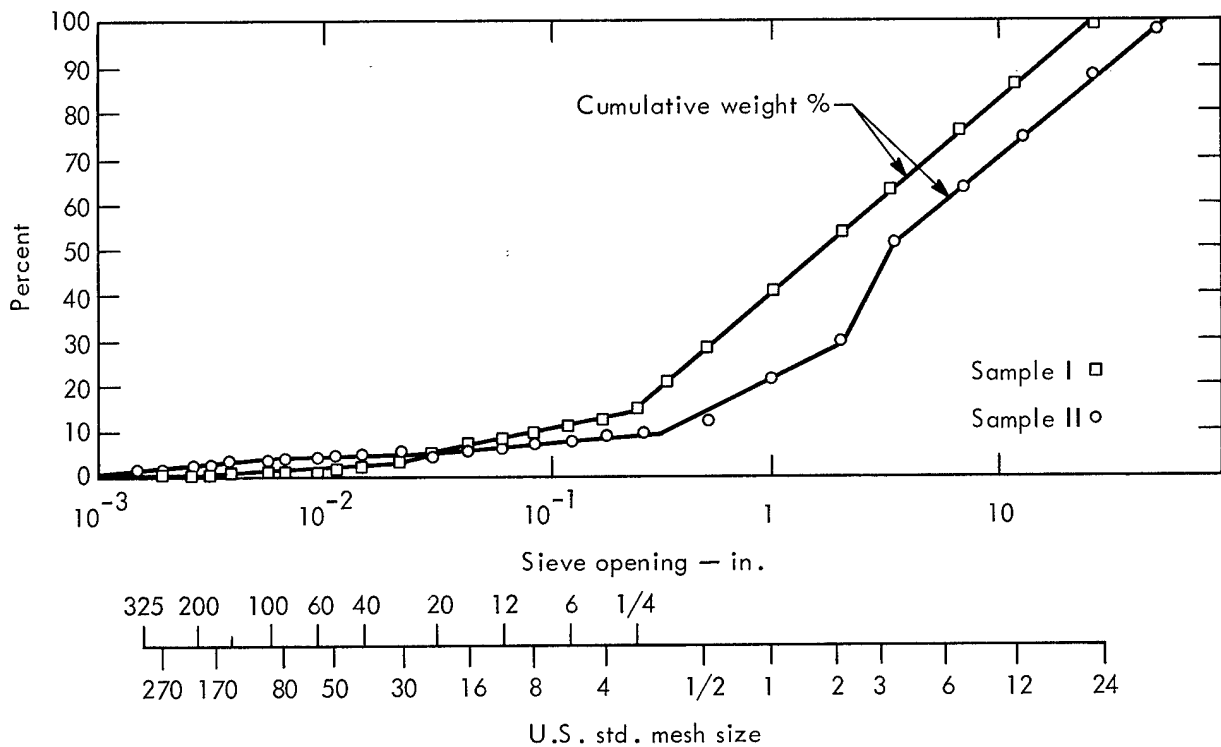

Fig. 6. Weight percent vs particle-size distribution.

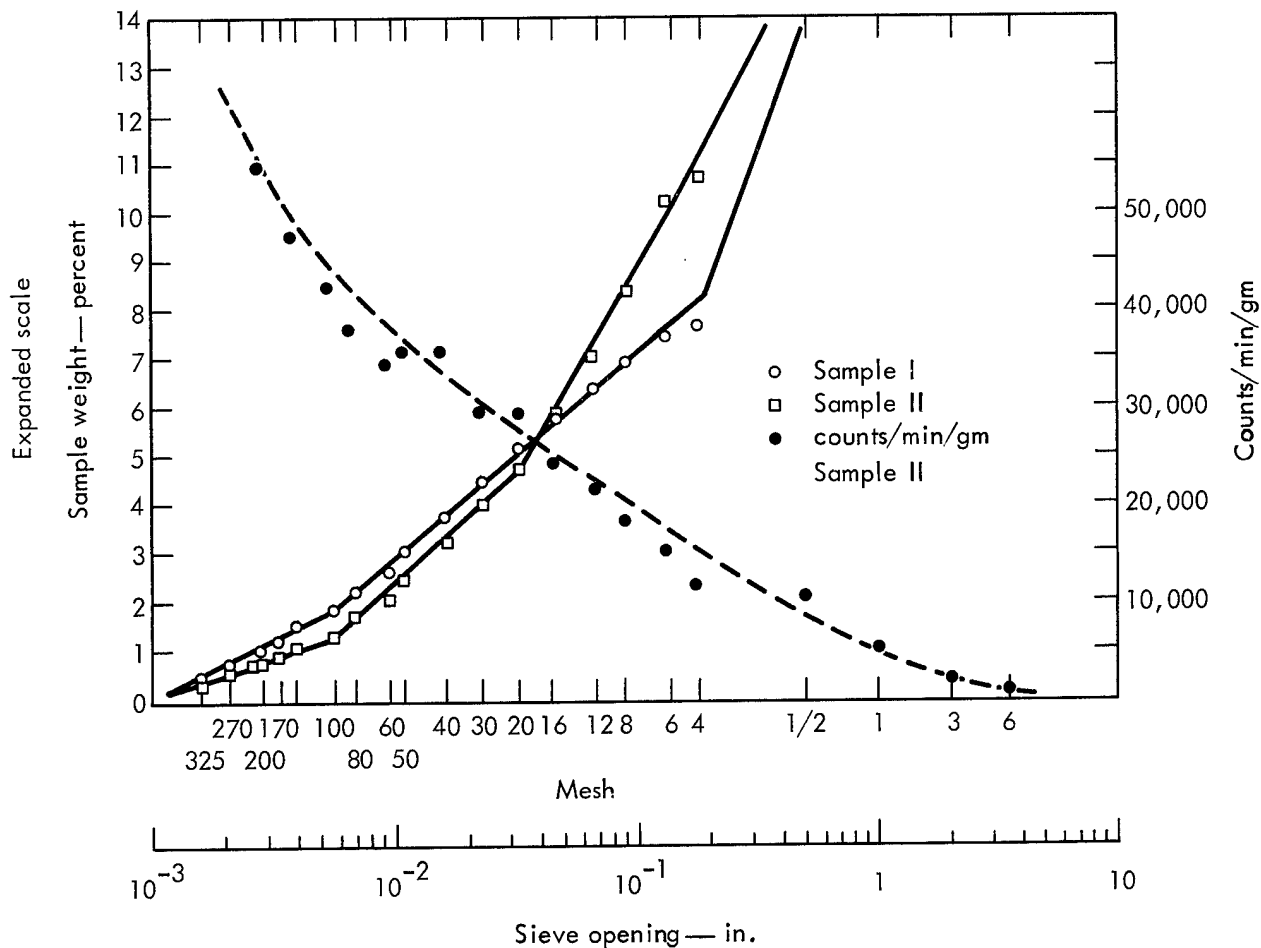

Fig. 7. Radioactivity and weight percent vs particle-size distribution on an expanded scale.

Photographs of the material at location of Sample I are shown in Fig. 8, and of Sample II in Fig. 9. It is the consensus of the author and individuals experienced in dump leaching of copper ores⁷ that this material possesses a particle-size distribution favorable to conventional leaching.

In addition to the screen analyses of Samples I and II, a study based on field observations and photographs of chimney rubble (as the slusher drift advanced) gave the particle-size distribution listed in Table III, column 2. These data are considered to be more representative of the average particle-size distribution in the Piledriver chimney than deduced from

either Samples I or II. A comparison, however, of these data with that available from Table II shows the particle sizes of Sample II in close agreement with the estimate typical for hardrock.

Also in Table III, this average Piledriver particle-size distribution is compared with similar data from Hardhat granite, Danny Boy basalt, Pre-Schooner rhyolite, and USBuM Anvil Point (Rifle) oil shale. The differences noted between the Piledriver data and among the rock types listed in Table III emphasize that petrology is not consistent and predictable from one location to another. Not only are there great differences among different rock types, but there are differences

Table III. Particle-size distributions.

Sieve size	Cumulative weight percent						Estimate typical for hard rock ⁱ
	Piledriver (observed) ^a	Piledriver Sample II ^{b, c}	Hardhat ^{d, e}	Danny Boy ^{e, f}	Pre-Schooner Delta ^{e, g}	Oil shale ^h	
6 ft	100	100	100	100	100	—	100
5 ft	99	—	95	88	100	—	94 - 96
4 ft	98	—	88	83	92	99	90 - 95
3 ft	95	93	75	75	74	—	80 - 85
2 ft	85	—	60	63	57	96	60 - 75
1 ft	60	—	40	43	38	90	40 - 60
6 in.	45	50	30	30	28	70	30 - 40
4 in.	30	—	25	24	25	—	25 - 30
3 in.	—	31	22	—	—	17	20 - 30
2 in.	20	—	20	15	20	—	15 - 20
1-1/2 in.	—	—	16	13	18	—	13 - 18
1 in.	15	14	14	11	16	—	15
3/4 in.	—	—	12	9	14	—	12
1/2 in.	11	11	10	8	12	—	10
3/8 in.	—	—	9	7	11	—	8
No. 4	10	8	7	5	8	—	6
20 mesh ^j	5	4	5	—	—	—	5

^aField observation and measurements by S. Hansen and D. Rabb (1967).

^bSample I is not considered representative of Piledriver chimney material, and therefore, is not included here.

^cBased on data in Table II.

^dEstimate based on Refs. 8 and 9.

^eData in approximate agreement with Ref. 10.

^fRef. 11.

^gRef. 12.

^hDerived from Ref. 13.

ⁱDependent upon fracture pattern and type of rock at specific site.

^jDependent upon grain size of host rock.

within a few feet in one rock type. Each specific location must be studied separately and evaluated on its own unique characteristics.

The final column in Table III is the author's estimate of a particle-size

distribution that might be encountered from nuclear blasts in a rock typical of some ore deposits. Note that 80 percent is smaller than 3 ft; about 50 percent is smaller than 1 ft; and the amount of minus 20-mesh material is about 5 percent.

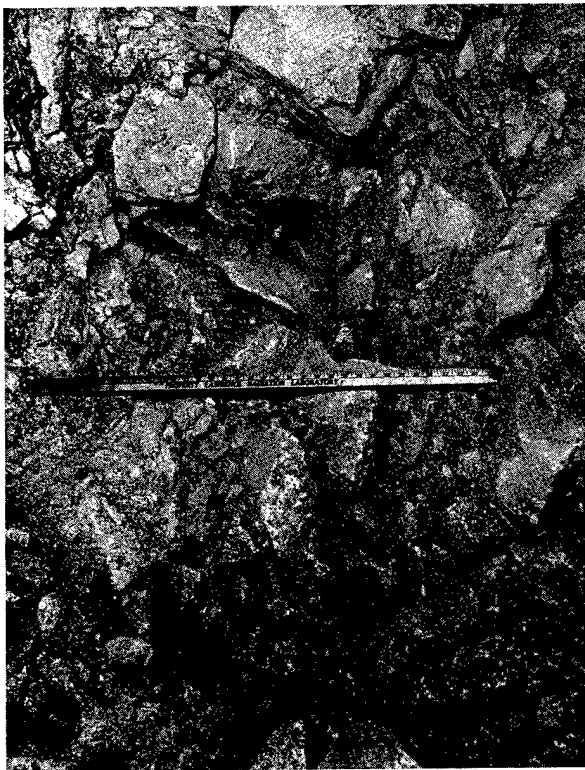

Fig. 8. Material at location of Sample I.

The bulk of the material, about 70 percent, is between 1 in. and 3 ft. With Piledriver rubble, this number is closer



Fig. 9. Material at location of Sample II.

to 80 percent. This combination of few very large boulders and almost no fines is favorable for in-place leaching.

Radioactive-Distribution Study

Further studies of the particle size-fractions of the two samples determined the amount of radioactivity in each separate fraction. Representative samples of each fraction were placed in a scintillation well-counter to determine the gross-gamma activity in counts per min per gm. The energy level of the counter was set at 0 to 0.71 MeV. From these data, the total counts per min and the percent of total activity in each size-fraction were calculated (see Table II), and the results plotted in Fig. 10. The cumulative percent of

radioactivity in size-fractions of Samples I and II are shown in Fig. 11, while the combined data of Figs. 6, 10, and 11 are presented in Fig. 12.

To save sample preparation time and effort, a brief study was made to determine if the particle size of material placed in the counter had any effect on the total counts per min. Duplicate counting runs compared 1/4-in., 10-, and 60-mesh material to an equal weight of the same material finely ground to about 100 mesh. The geometry of the two samples was the

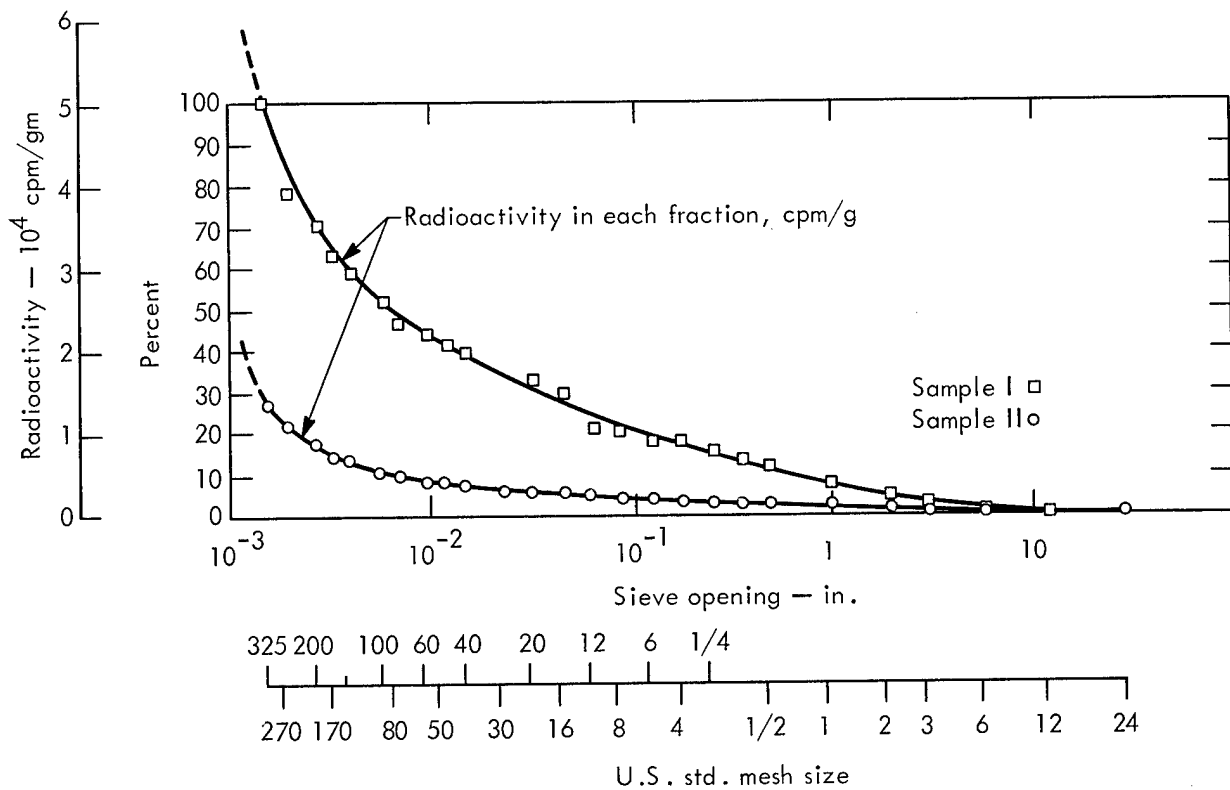

Fig. 10. Counts per minute vs particle-size distribution.

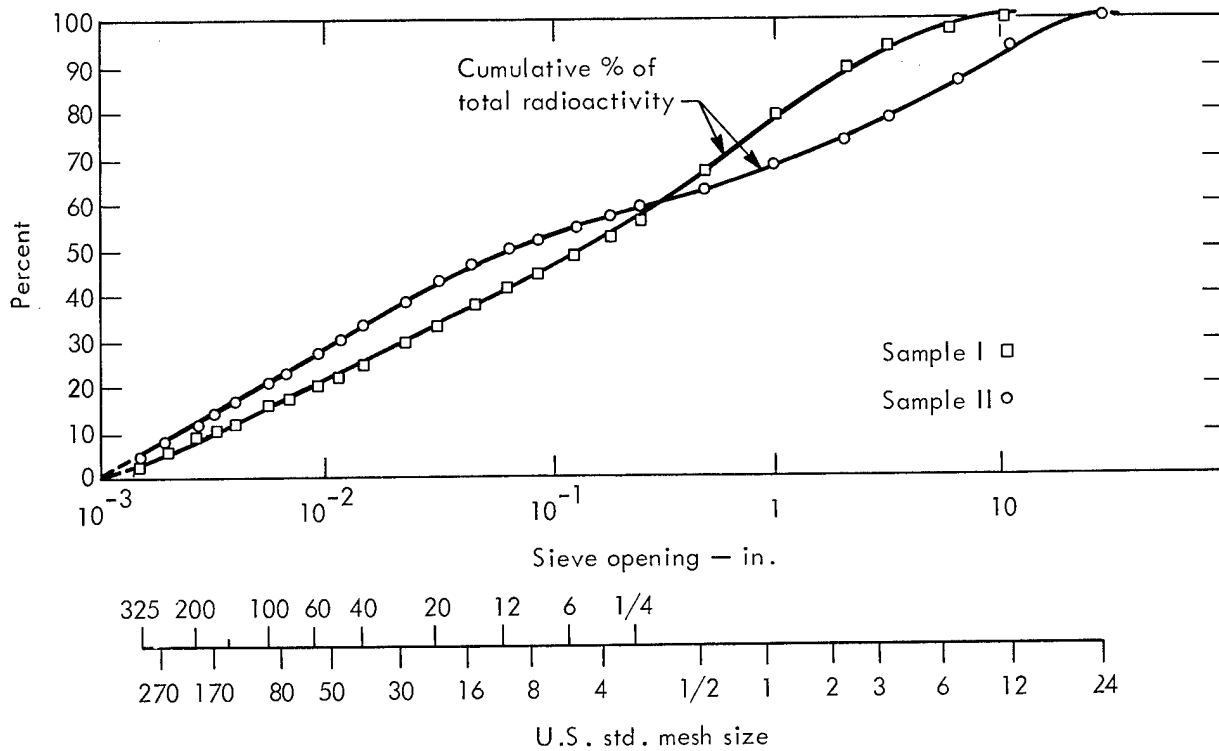

Fig. 11. Cumulative percent of total radioactivity vs particle-size distribution.

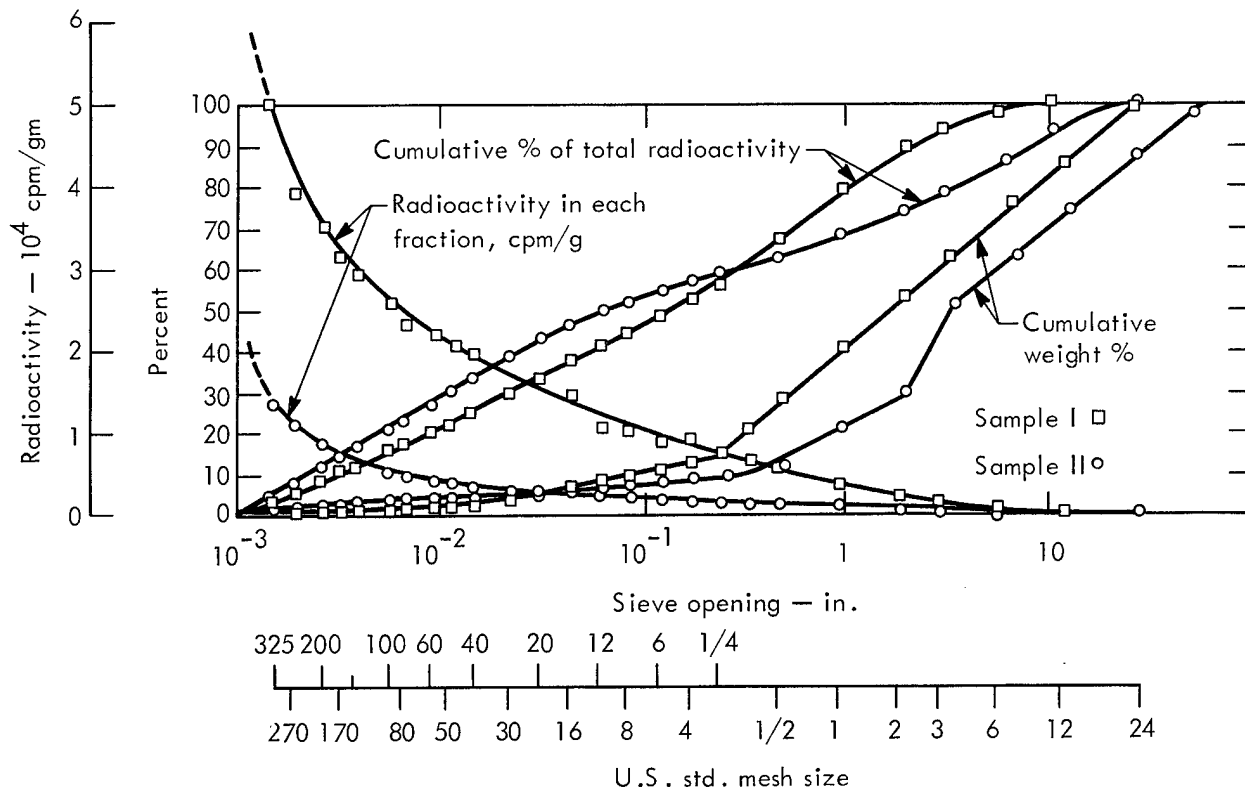

Fig. 12. Combined radioactivity data and weight percent vs particle-size distribution.

same except the depths of material in the counting vials varied slightly. This small (less than 10 percent maximum) difference in depth of samples had no significant effect, and the results were essentially the same as long as weights of material were equal. The gross-gamma counts varied directly with the weight of the sample. In other words, as long as portions of the same particle size-fraction were of equal weight, they counted the same, regardless of the degree of fineness of the material being counted.

From the data in Table II and in Figs. 10 and 11, the radioactivity per gm is inversely proportional to particle size, and is, roughly, a function of surface area. This generalization does not hold true in the minus 100-mesh sizes, prob-

ably because of the less-than-spherical shapes of the fine shards of the mineral grains. Though Sample I contains more gross-gamma activity than Sample II by a factor of 3, results of this study indicate that, in both samples, the minus 100-mesh material may be only 1.5 percent of weight, but traps 20 percent of the radioactivity. Conversely, the plus 1-in. portion comprises 80 percent of the weight and contains only 20 percent of the radioactivity. The higher concentrations of gross gamma in the fine material may present a potential hazard if sand-slime filters are used to clarify leaching solutions. The slimes from leaching solutions off of a chimney could involve a considerable concentration of radioactivity. The magnitude of this problem depends upon the individual site conditions and the particular nuclear

explosive used. It must be evaluated separately for each site.

One theory as to why there is a higher concentration of radioactivity near the edge of the chimney is the following. In the early stages of the explosion when the cavity is growing and rock above is being moved, there is tendency for a plug fault, or cork-type, movement. The rock directly over zero point moves up en masse, and most of the separation or shearing movement occurs in an area circular in shape about where the chimney

wall forms later. As the plug pops up, there are many step-faults. This fault series, or shear zone, is evident in the offsets of the horizontal barber-pole* hole which was explored after the Hardhat Event (see Fig. 13).¹⁴ This phenomenon allows a more ready access of gasses and radioactivity in this area than in the center of the chimney.

* A horizontal preshot hole about 100 ft above zero point filled with colored grout and containing a tape measure.

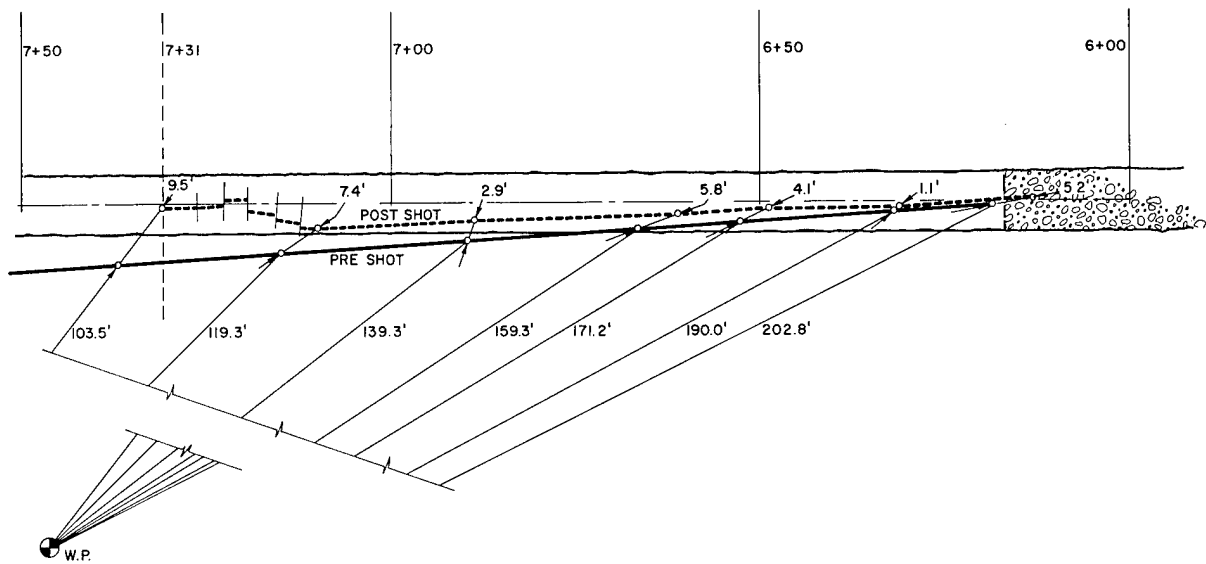

Fig. 13. Cross section of postshot reentry exploration drift showing postshot movement of barber pole.

Small-Scale Batch-Leaching Tests

To obtain some preliminary approximation of the behavior of radioactivity during a possible leaching in place, representative portions of particle size-fractions of Samples I and II underwent a simulated film-percolation leach test as follows:

A measured amount of liquid at room temperature (70 to 75°F) was dripped

slowly over a weighed sample of the sized material, and the effluent OFF-solution (and slimes) collected. Duplicate tests were made for each size-fraction sample; one using 0.1 N sulphuric acid solution (pH ≈ 1.5), the other distilled water. Each sample was suspended in a stainless steel funnel over an enamel tub. Every attempt was made to slowly wet all the surfaces

with no jetting, hydraulic washing, or mechanical scrubbing. The leaching cycle was continued for about 2 hr or until the radioactivity in the effluent was negligible. Then the sample was rinsed with water and dried, and a representative sample was prepared for gross-gamma analysis in the scintillation well-counter. In Table IV, the counts per min of the tails (residue) from water and acid leach tests are compared to the counts per min of the untreated heads samples.

Results indicate an average of about 25 percent of the radioactivity is removed by this short-time water percolation leach, and about 40 percent if dilute acid is used. It is the author's opinion that about 33 percent of the radioactivity in the nuclear chimney being leached will be removed in the first slug of leach liquor, and possibly a large portion of this will be in the slimes. After that, additional dissolution and extraction will proceed at a slower rate. It may take years to

attain 60 or 75 percent extraction from such a chimney.

Solutions and slimes fractions are awaiting chemical assays. But preliminary assays for Ru, Cs, Sb, Ce, and Eu of some of the size-fractions of the two samples indicate that each of the specific nuclides are distributed throughout the various sizes in the same proportion as the gross-gamma activity is distributed. Therefore, it is felt that chemical analyses of the heads sample, and of one selected size-fraction, will permit a close approximation of the specific activities in the other size-fractions, thus saving analytical time and labor.

In an attempt to prove that radioactivity in Piledriver rubble is concentrated on (and confined to) the surface of the particles, microradiophotographs were prepared of several size-fractions of Sample I. No clear confirmation of this theory was attained, probably because of the very low level of activity. However, studies along this line are continuing.

Table IV. Percolation leach-test results.

Sample	Particle size		Radioactivity (counts/min/gm)			% removed by leaching	
			Heads	Tails		Acid	Water
	Minus	Plus		Acid	Water		
I	—	6 in.	0.3	0.15	0.3	50	0
	6 in.	1 in.	2.9	1.5	1.8	48	38
	1 in.	1/4 in.	4.3	1.9	2.2	56	51
	1/4 in.	20 mesh	9.9	6.1	8.1	38	18
	20 mesh	—	22.1	12.6	12.7	43	43
					Average	47	30
II		6 in.	0.2	0.5	0.15	75	25
	6 in.	1 in.	0.5	0.37	0.45	25	10
	1 in.	1/4 in.	1.3	0.8	1.1	38	15
	1/4 in.	20 mesh	3.8	2.8	3.0	26	21
	20 mesh	—	7.9	5.3	6.1	33	23
					Average	40	19

Acknowledgments

Special thanks is given to individuals contributing to this work: Gaylan Adair, REECo Mine Superintendent, NTS, for the design and economical accomplishment of the reentry; Hugh Wilson, USBuMines, Salt Lake City, for sample preparation; C. R. Boardman, LRL Geologist, for drilling program; J. S. Kahn and LRL Geo-Sciences Group, for

guidance, supervision, and radioactivity analyses, and M. D. Nordyke for a critical reading and aid in data interpretation.

Also, to the DOD Staff for Piledriver Event: Lt. Col. Bernard Robinson, DOD, DASA, Test Director, Sandia Base, Albuquerque, New Mexico; and Prof. J. L. Merritt, Chief Scientist, Univ. of Illinois, for their valuable cooperation.

References

1. C. R. Boardman, Results of an Exploration into the Top of the Piledriver Chimney, Lawrence Radiation Laboratory, Livermore, Rept. UCRL-50385 (1967).
2. C. R. Boardman, Some Characteristics of the Hardhat Chimney and Surrounding Wall Rock, Lawrence Radiation Laboratory, Livermore, Rept. UCRL-50177 (1966).
3. C. R. Boardman, A Measurement of the Volume of Void in the Shoal Chimney, Lawrence Radiation Laboratory, Livermore, Rept. UCRL-50150 (1966).
4. D. L. Springer, Lawrence Radiation Laboratory, Livermore, private communication (1967).
5. H. A. Tewes, Lawrence Radiation Laboratory, Livermore, private communication (1968).
6. C. R. Boardman, Lawrence Radiation Laboratory, Livermore, private communication (1968).
7. E. E. Malouf, Metallurgist, Kennecott Copper Corporation, Salt Lake City, Utah; William R. Hardwick, Engineer, U. S. Bureau of Mines, Tucson, Arizona; and Dr. George Griswold, Staff, New Mexico Institute of Mining and Technology, Socorro, New Mexico, private communication (1968).
8. C. R. Boardman, D. D. Rabb, and R. D. McArthur, Characteristic Effects of Contained Nuclear Explosives for Evaluation of Mining Applications, Lawrence Radiation Laboratory, Livermore, Rept. UCRL-7350 Rev. I (1963).
9. H. C. Rodean, The Particle Statistics of Rubble Produced by Underground Nuclear Explosions, Lawrence Radiation Laboratory, Livermore, Rept. UCRL-12129 (1964).
10. S. M. Hansen and J. Toman, Aggregate Productions with Nuclear Explosives, Lawrence Radiation Laboratory, Livermore, Rept. UCRL-12180 Rev. I (1965).
11. U. S. Army Corps of Engineers, Waterways Experiment Station, Vicksburg, Miss., Investigations of Manufacture of Rip-Rap and Aggregate by Nuclear Methods, AEC Rept. PNE-5003 (1965).

12. U. S. Army Corps of Engineers, Waterways Experiment Station, Vicksburg, Miss., Project Pre-Schooner, Geologic Investigations and Engineering Properties of Craters, AEC Rept. PNE-505 (1967).
13. D. B. Lombard, The Particle Size Distribution and Bulk Permeability of Oil Shale Rubble, Lawrence Radiation Laboratory, Livermore, Rept. UCRL-14294 (1965).
14. D. D. Rabb, A Mining Experiment in Granite, Lawrence Radiation Laboratory, Livermore, Rept. UCRL-7608 (1963).

Distribution

LRL Internal Distribution

Michael M. May
G. Werth
H. Reynolds
G. Higgins
P. Moulthrop
F. Eby
J. Carothers
M. Nordyke
J. Kahn
J. Knox
H. Tewes
T. Cherry
C. Boardman
A. Lewis
R. Heckman
D. Snoeberger
L. Schwartz
A. Prindle
TID Berkeley
TID File

30

External Distribution

R. Hamburger
U. S. Atomic Energy Commission
Washington, D. C.

J. F. Philip
U. S. Atomic Energy Commission
Berkeley, Calif.

J. E. Reeves
U. S. Atomic Energy Commission
Las Vegas, Nevada

J. S. Kelly
U. S. Atomic Energy Commission
Washington, D. C.

20

TID-4500 Distribution, UC-35, Nuclear Explosions—
Peaceful Applications

255

Printed in USA. Available from the Clearinghouse for Federal
Scientific and Technical Information, National Bureau of Standards,
U. S. Department of Commerce, Springfield, Virginia 22151
Price: Printed Copy \$3.00; Microfiche \$0.65.

LEGAL NOTICE

This report was prepared as an account of Government sponsored work
Neither the United States nor the Commission nor any person acting on behalf
of the Commission:

A. Makes any warranty or representation, expressed or implied, with
respect to the accuracy, completeness, or usefulness of the information con-
tained in this report, or that the use of any information, apparatus, method, or
process disclosed in this report may not infringe privately owned rights; or

B. Assumes any liabilities with respect to the use of or for damages
resulting from the use of any information, apparatus, method or process dis-
closed in this report.

As used in the above, "person acting on behalf of the Commission"
includes any employee or contractor of the Commission, or employee of such
contractor, to the extent that such employee or contractor of the Commission,
or employee of such contractor prepares, disseminates, or provides access to,
any information pursuant to his employment or contract with the Commission,
or his employment with such contractor.

RC/hk