

73885

NASA TECHNICAL NOTE

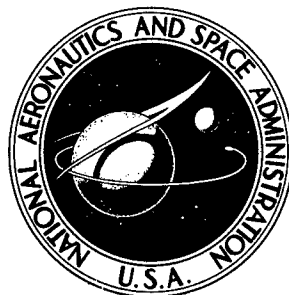

NASA TN D-5000

NASA TN D-5000

**DISTRIBUTION STATEMENT A**  
Approved for Public Release  
Distribution Unlimited

# AMPTIAC

HOT-SALT STRESS-CORROSION  
OF TITANIUM ALLOYS:  
GENERATION OF HYDROGEN  
AND ITS EMBRITTLING EFFECT

*by Hugh R. Gray*  
*Lewis Research Center*  
*Cleveland, Ohio*

THIS QUALITY INSPECTED 4

Reproduced From  
Best Available Copy

20000906 093

NASA TN D-5000

HOT-SALT STRESS-CORROSION OF TITANIUM ALLOYS: GENERATION  
OF HYDROGEN AND ITS EMBRITTLING EFFECT

By Hugh R. Gray  
Lewis Research Center  
Cleveland, Ohio

NATIONAL AERONAUTICS AND SPACE ADMINISTRATION

---

For sale by the Clearinghouse for Federal Scientific and Technical Information  
Springfield, Virginia 22151 - CFSTI price \$3.00

## ABSTRACT

Alloy specimens of Ti-8Al-1Mo-1V were salt-coated and exposed to conditions conducive to hot-salt stress-corrosion. Subsequent tensile tests revealed that ductility was strain-rate and temperature sensitive. Embrittlement was more pronounced at slow crosshead speeds in the vicinity of ambient temperature. After salt-exposure, ductility was restored by vacuum annealing. Substantial increases in hydrogen content were measured in embrittled specimens. These results demonstrate that hydrogen can be generated during elevated temperature exposure to salt and that the subsequent embrittlement is a manifestation of the phenomenon of "slow-strain-rate" hydrogen embrittlement.

# HOT-SALT STRESS-CORROSION OF TITANIUM ALLOYS: GENERATION OF HYDROGEN AND ITS EMBRITTLING EFFECT

by Hugh R. Gray

Lewis Research Center

## SUMMARY

The hypothesis that hydrogen is the cause of the embrittlement observed in titanium alloys after exposure to conditions conducive to hot-salt stress-corrosion was investigated. Hollow tensile specimens of titanium - 8-aluminum - 1-molybdenum - 1-vanadium alloy were coated with 0.2 milligram per square inch ( $0.03 \text{ mg/cm}^2$ ) salt, which is representative of average deposits measured on compressor airfoils of flight aircraft, gas-turbine engines. After being coated with salt, the specimens were exposed at  $800^\circ \text{ F}$  ( $425^\circ \text{ C}$ ) for 100 hours while being stressed at 50 000 psi ( $350 \text{ MN/m}^2$ ). Subsequent to exposure, specimens were tensile tested over a range of temperatures and crosshead speeds (strain rates).

Embrittlement was strongly dependent on the tensile crosshead speed and the test temperature. For the temperature range from ambient temperature to about  $300^\circ \text{ F}$  ( $150^\circ \text{ C}$ ), more severe embrittlement occurred at low crosshead speeds. For a constant crosshead speed of 0.005 inch per minute ( $0.01 \text{ cm/min}$ ) greater embrittlement was observed in the vicinity of ambient temperature.

Embrittlement was eliminated from salt-exposed specimens by a vacuum annealing heat treatment at  $1200^\circ \text{ F}$  ( $650^\circ \text{ C}$ ). Higher hydrogen contents (up to 255 ppm) were measured in areas immediately adjacent to the fracture surfaces of embrittled specimens than in the as-received material (70 ppm).

These results lend credence to the previously proposed hydrogen embrittlement concept for titanium alloy hot-salt stress-corrosion. The observed temperature and strain-rate sensitivity suggests that a diffusible species, such as hydrogen, controls the embrittling process. Recovery of ductility after vacuum annealing further substantiates the concept. Local increases in hydrogen content at fracture surfaces verifies that hydrogen is generated and absorbed during exposure conditions conducive to hot-salt stress-corrosion and that the observed loss of ductility is a manifestation of "slow-strain-rate" hydrogen embrittlement. The observed temperature and strain-rate sensitivity may also help to rationalize the differences among reported threshold curves for titanium alloy hot-salt stress corrosion.

## INTRODUCTION

The phenomenon of hot-salt stress-corrosion of titanium alloys is of interest because of extensive utilization of titanium alloys in gas-turbine engines. Laboratory investigations (refs. 1 to 12) have demonstrated that titanium alloys are susceptible to embrittlement at elevated temperatures while being stressed in the presence of moisture and halides. Similar conditions of stress, temperature, and salt-air environment can be experienced in compressor components of current engines. Advanced-engine designs are expected to specify that titanium alloy compressor components operate at even higher stress levels and higher temperatures. Consequently, there is concern that hot-salt stress-corrosion might become a significant, and, perhaps, limiting factor in the use of titanium alloys in these applications. To date, no service failures that could conclusively be attributed to this phenomenon have been reported (ref. 13). The rationalization for the lack of service failures is not clear, nor is the exact mechanism of titanium alloy embrittlement encountered in laboratory tests completely understood.

One of the most preferred laboratory test techniques involves the exposure of statically loaded, salt-coated specimens in the temperature range 500<sup>0</sup> to 900<sup>0</sup> F (260<sup>0</sup> to 480<sup>0</sup> C) for 100 hours or longer (refs. 1 to 6). These specimens are then examined for evidence of corrosion or cracking, and may be subjected to mechanical testing, such as bend or tensile testing. The results are then interpreted on an embrittlement or no-embrittlement basis. The boundary line on a plot of stress against temperature separating regions of cracking from no-cracking or embrittlement from no-embrittlement has been termed the threshold curve. Wide variations in threshold curves exist from investigator to investigator because of differences in test conditions and the criteria used for defining stress-corrosion. Obviously, those who define the onset of stress-corrosion as the visual appearance of cracks or corrosion products will report a different curve from those investigators concerned with catastrophic decreases in ductility.

Among the many potential variables in these studies, the following are considered important: material composition and processing history, specimen geometry, nature and amount of salt coating, environmental conditions during exposure, and the procedure for testing after exposure. The relative sensitivity of various alloys to hot-salt stress-corrosion and the beneficial effects due to various heat treatments have been reported by numerous investigators (refs. 1 to 4 and 7). The effects of moisture, oxygen, pressure, and various halides have also been considered (refs. 5, 6, 8, and 9). Reports of similar damage caused by sodium chlorides natural sea salt, and synthetic sea salt have been in agreement (refs. 1, 6, and 10), as well as in conflict (refs. 2, 3, 5, and 9).

Although the thickness and continuity (i. e., concentration) of the salt coating have been considered by a few investigators to be important variables (refs. 3 and 5), the majority of previous investigators have applied concentrated slurries of salt solutions, by means of alternate wetting and drying cycles, until thick coatings of salt crystals developed. Typical coating thicknesses ranged from 0.002 inch (0.005 cm) (refs. 11 and 12) up to about 0.1 inch (0.2 cm) (refs. 1, 4, and 9). When converted to a concentration basis, these coatings represent about 40 to 2000 milligrams per square inch (6 to 300 mg/cm<sup>2</sup>).<sup>1</sup> It is significant that a recent study (ref. 13) indicates that average salt concentrations of about 0.1 milligram per square inch (0.02 mg/cm<sup>2</sup>) occur on compressor airfoils after normal, operating conditions (transoceanic flight). Salt deposits up to 1 milligram per square inch (0.2 mg/cm<sup>2</sup>) can result during exposure to severe environmental conditions in flight (helicopter hovering over the ocean). Local concentrations up to 10 times the average have been measured (ref. 13).

It has been suggested that hot-salt stress-corrosion of titanium alloys is the result of hydrogen embrittlement (refs. 9 and 14). Corrosion reactions have been postulated involving titanium, salt, oxygen, and moisture that result in the generation of hydrogen (refs. 7 to 9). The primary purpose of this study was to investigate the hypothesis that hydrogen is the cause of the embrittlement observed in titanium alloys after typical laboratory hot-salt stress-corrosion tests.

It is also well known that titanium alloys containing electrolytically or thermally charged hydrogen exhibit temperature and strain-rate sensitive behavior (refs. 15 to 18). Such sensitivity suggests that postexposure testing variables alone could account to a great degree for the differences among reported threshold curves for titanium alloy stress-corrosion. Because of the lack of standardization on tensile testing, let alone bend testing, procedures employed in previous studies, it is believed that the potential influence of strain rate and testing temperature on the degree of embrittlement has been neglected. Hence, another purpose of this investigation was to determine the degree of temperature and strain-rate sensitivity exhibited by a commonly used titanium alloy exposed under laboratory test conditions conducive to hot-salt stress-corrosion.

Titanium alloy specimens were coated with salt concentrations representative of those measured in flight engines. Specimens were then exposed for 100 hours at a stress and temperature considered to be well within the stress-corrosion region based on previously reported data (refs. 1, 4, 8, and 19). Subsequent tensile tests were conducted over a range of strain rates and temperatures. The influence of vacuum annealing after exposure and prior to tensile testing was investigated. Hydrogen gas analyses were performed after a variety of exposure conditions.

---

<sup>1</sup>The mixed units of mg/in.<sup>2</sup> are reported because of the numerous precedents in the literature.

# MATERIALS, APPARATUS, AND PROCEDURE

## Materials

21.1  
Ref. 3. A titanium-8-aluminum - 1-molybdenum - 1-vanadium <sup>Ti</sup> (Ti-8Al-1Mo-1V) alloy in the mill-annealed condition (1650° F (900° C) for 1 hr, water quenched) was used in this investigation. This alloy and heat treatment were selected because the literature indicated greater susceptibility in this condition (ref. 3). The manufacturer's reported chemical analysis (in wt. %) of the 1-inch (2.5-cm) diameter bar stock and tensile properties are as follows:

Al	Mo	V	C	Fe	N	O	H	Ti
7.8	1.0	1.0	0.023	0.05	0.11	0.07	0.007	Bal.

Yield strength, psi; MN/m <sup>2</sup> . . . . .	142 000; 980
Ultimate tensile strength, psi; MN/m <sup>2</sup> . . . . .	148 000; 1020
Elongation, percent . . . . .	20
Reduction in area, percent . . . . .	40

## Specimens

The hollow tensile specimens employed in this investigation are illustrated in figure 1. This type of specimen was selected so that salt coatings could be deposited on the bore of the specimen under conditions similar to those existing in flight engines, as will be described subsequently. The specimens were machined from as-received bar stock and received no subsequent treatments except cleaning with acetone immediately prior to salting. Standard chemical etching and cleaning procedures were not employed so that possible hydrogen contamination could be avoided.

## Apparatus

21.1  
Ref. 3. In order to simulate in the laboratory the salt-air environment encountered in compressor airfoils during flight, the facility illustrated in figure 2 was constructed. This rig enables the effects of salt-in-air concentration, air velocity, pressure, temperature, and humidity to be evaluated in relation to salt deposition. → 6

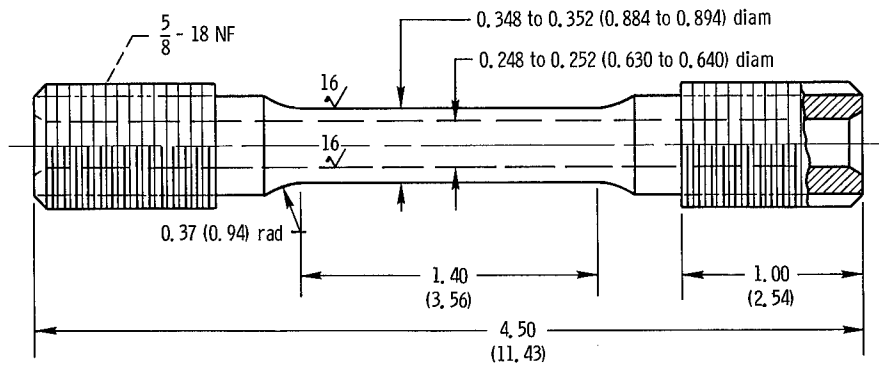

Figure 1. - Hollow titanium alloy tensile specimen used in hot-salt stress-corrosion investigation.  
(All dimensions are in inches (cm).)

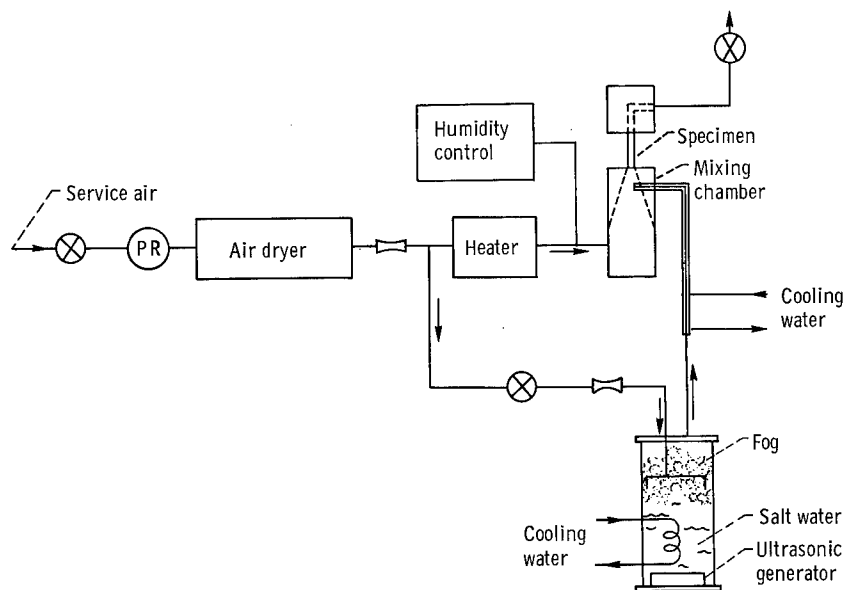

Figure 2. - Salt deposition apparatus which simulates turbine-engine operating conditions.

Service air can be dried to a dewpoint of approximately  $-120^{\circ}\text{F}$  ( $-85^{\circ}\text{C}$ ), heated to  $1000^{\circ}\text{F}$  ( $540^{\circ}\text{C}$ ), and humidified, if desired, before passing through the hollow specimen. A small amount of the dry air passes through a vessel containing an ultrasonically generated salt-water fog with an average particle size of 1 micrometer. This fog is injected continuously into the heated airstream just upstream of the specimen. Any desired concentration of salt in air can be obtained by adjusting the air mass flow rate, salt-water concentration, or usage rate.

## Procedure

Salt coating. - Before high-temperature exposure, all specimens to be salted were coated with an average salt (chemically pure NaCl) coating of about 0.2 milligram per square inch ( $0.03\text{ mg/cm}^2$ ). This average concentration was achieved with the rig described by exposing unstressed specimens for 1 hour to a salt-in-air concentration of 40 parts per billion at an air velocity of 1000 feet per second ( $300\text{ m/sec}$ ), an air temperature of  $400^{\circ}\text{F}$  ( $205^{\circ}\text{C}$ ), a dewpoint of  $-120^{\circ}\text{F}$  ( $-85^{\circ}\text{C}$ ), and a pressure of 30 psia ( $0.2\text{ MN/m}^2$ ). This technique provided a uniform dispersion of salt particles on the bore of the specimen, as may be seen in figure 3. It is evident that the crystals are cubic in symmetry and submicrometer in size.

Exposure conditions. - Salt-coated specimens were exposed in static air furnaces at  $800^{\circ}\text{F}$  ( $425^{\circ}\text{C}$ ) for approximately 100 hours while being stressed at 50 000 psi ( $350\text{ MN/m}^2$ ). In order to ensure that embrittlement would occur, exposure conditions were selected well above even the most conservative threshold curve reported in the literature (see fig. 4). In one case, a stress-rupture test (i.e., specimen run to failure) was conducted at  $800^{\circ}\text{F}$  ( $425^{\circ}\text{C}$ ) at a stress level of 80 000 psi ( $550\text{ MN/m}^2$ ).

Tensile testing. - Subsequent to exposure, specimens were tensile tested over a range of crosshead speeds and temperatures. Specifically, the crosshead speeds employed were 0.005, 0.05, and 0.5 inch per minute (0.01, 0.1, and 1 cm/min). Test temperatures ranged from ambient to about  $300^{\circ}\text{F}$  ( $150^{\circ}\text{C}$ ). Elongation data were measured over a 1.00-inch (2.54-cm) gage length. A complete listing of all tests conducted is presented in table I.

Vacuum annealing. - A vacuum annealing treatment at  $1200^{\circ}\text{F}$  ( $650^{\circ}\text{C}$ ) for 24 hours at less than  $10^{-3}$  torr ( $0.13\text{ N/m}^2$ ), followed by furnace cooling, was employed on selected specimens after salt-exposure.

Hydrogen analyses. - Vacuum fusion chemical analyses were conducted on material in the as-received, salted and exposed, and vacuum annealed conditions. For the exposed, tensile tested specimens, small samples ( $\sim 0.1\text{ mg}$ ) were cut from regions immediately adjacent to the fracture surfaces for hydrogen content analyses.

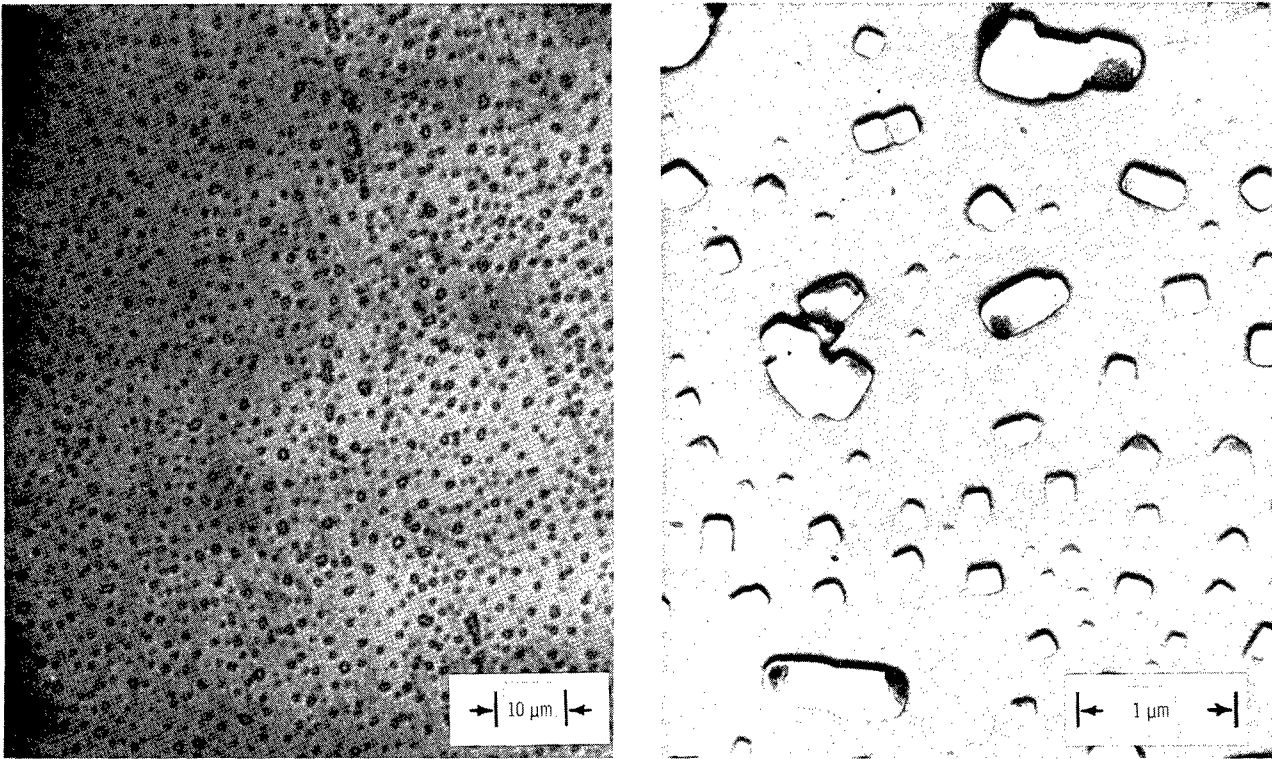

C-68-3781

Figure 3. - Salt crystals deposited on hollow titanium alloy specimens at 400° F (205° C).

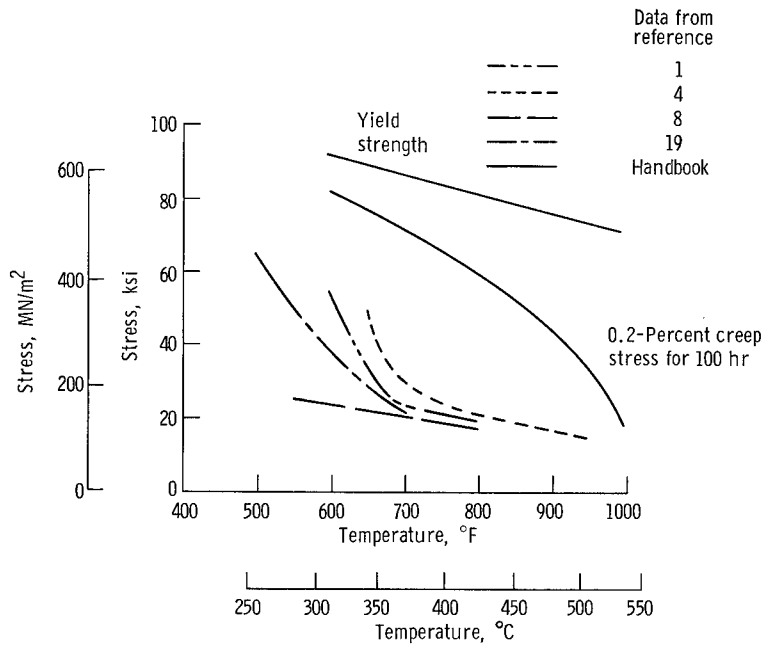

Figure 4. - Typical 100-hour threshold curves for hot-salt stress-corrosion of Ti-8Al-1Mo-1V. Yield strength and creep data are shown for as-received material.

TABLE I. - SUMMARY OF TESTS CONDUCTED

Salt coating <sup>a</sup>		Exposure conditions				Tensile test data											
mg/in. <sup>2</sup>	mg/cm <sup>2</sup>	Temperature		Time, hr	Stress		Temperature		Crosshead speed		Ultimate tensile		Fracture strength		Reduction in area, percent	Elongation, percent	
		°F	°C		ksi	MN/m <sup>2</sup>	°F	°C	in./min	cm/min	ksi	MN/m <sup>2</sup>	ksi	MN/m <sup>2</sup>			
---	---	---	---	---	---	---	---	72	22	0.5	1	148	1020	136	940	27	15
---	---	---	---	---	---	---	---	72	22	.05	.1	150	1030	145	1000	22	17
---	---	---	---	---	---	---	---	72	22	.005	.01	148	1020	131	905	34	18
---	---	---	---	---	---	---	---	325	165	.005	.01	131	905	115	795	36	18
---	---	800	425	96	50	350	72	22	.5	1	151	1040	135	930	31	15	
---	---	---	---	100	---	---	---	---	---	.05	.1	154	1060	138	950	30	18
0.24	0.037	---	---	115	---	---	---	---	---	.005	.01	147	1010	136	940	31	19
.23	.036	---	---	115	---	---	---	---	---	.05	.1	151	1040	138	950	32	16
.05	.008	---	---	93	---	---	---	---	---	.005	.01	145	1000	145	1000	9	5
.15	.023	---	---	97	---	---	---	325	165	.005	.01	131	905	116	800	38	19
.23	.036	---	---	94	---	---	---	165	75	.005	.01	137	950	128	885	29	15
.21	.033	---	---	96	---	---	---	125	50	.005	.01	141	970	141	970	11	6
.13	.020	---	---	96	---	---	---	130	55	.05	.1	148	1020	135	930	27	19
.23	.036	---	---	96	---	---	---	72	22	.005	.01	b <sub>152</sub>	b <sub>1050</sub>	b <sub>139</sub>	b <sub>960</sub>	b <sub>29</sub>	b <sub>18</sub>
.18	.028	---	---	285	---	80	550	(c)	(c)	(c)	(c)	---	---	---	---	5	6

<sup>a</sup>Measured after tensile testing.<sup>b</sup>Vacuum annealed after salting and exposure.<sup>c</sup>Stress rupture.

Metallography. - Standard electron fractographic replicating techniques were employed to compare the fracture surfaces of specimens representative of nonembrittled and embrittled conditions.

## RESULTS AND DISCUSSION

### Effect of Tensile Test Crosshead Speed

5 Tensile testing speed has a dramatic effect on the postexposure ductility of salted Ti-8Al-1Mo-1V alloy specimens, as may be seen from figure 5. Specifically, elongation decreased as the testing speed decreased. At a fast crosshead speed of 0.5 inch per minute (1 cm/min) salted-exposed specimens exhibited no loss of elongation when compared with the elongation of similarly exposed nonsalted specimens. However, the elongation of salted-exposed material, which was about 17 percent at the fast testing speed, decreased to 5 percent at the slowest testing speed of 0.005 inch per minute (0.01 cm/min).

The 800° F (425° C) exposure, in itself, had no effect on subsequent ductility of unsalted material over the entire crosshead-speed range investigated. As is evident from figure 5, elongation of unsalted-exposed specimens at all crosshead speeds was unchanged from that determined for as-received material.

The appearance of the fracture surface of the embrittled material was drastically altered from that of the normal, unsalted material. Electron fractographs of an unsalted-exposed specimen and a specimen that had been embrittled to 5-percent elongation are

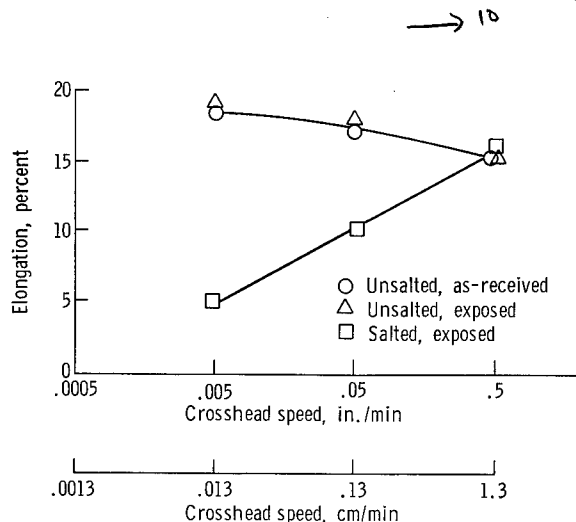

Figure 5. - Effect of tensile testing speed on the ductility of Ti-8Al-1Mo-1V alloy specimens after salting and exposure at 800° F (425° C) for 100 hours at 50 000 psi (350 MN/m<sup>2</sup>). Test temperature, 72° F (22° C).

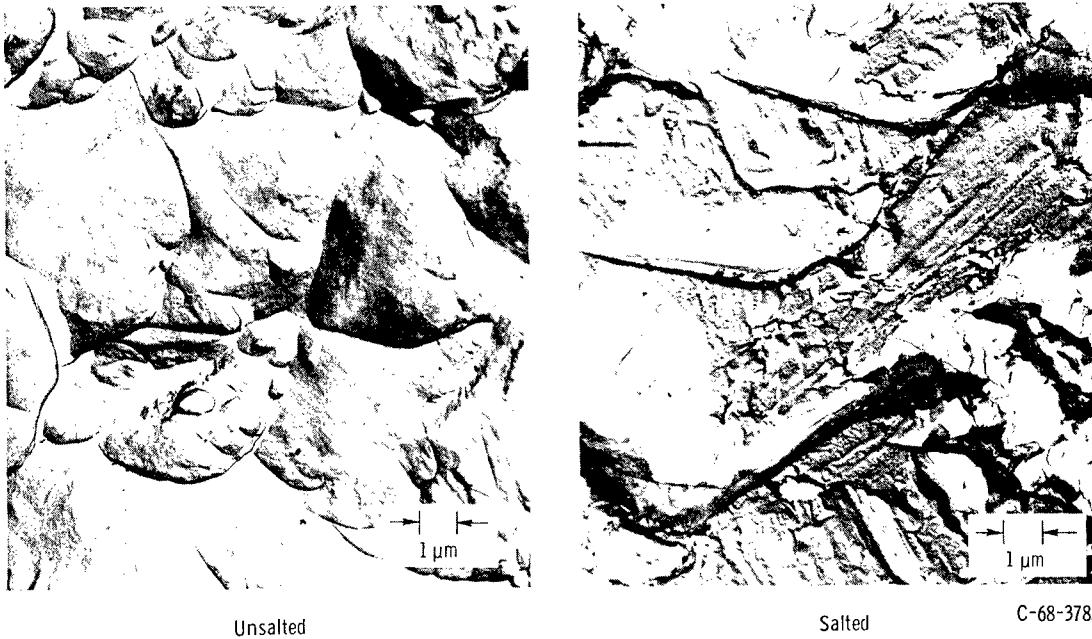

Figure 6. - Electron fractographs of typical fracture surfaces of tensile tested Ti-8Al-1Mo-1V alloy specimens previously exposed at 800° F (425° C) for 100 hours at 50 000 psi (350 MN/m<sup>2</sup>).

presented in figure 6. It is immediately evident that the primary fracture mode has changed from the dimple formation in the ductile material to a cleavage mode in the brittle material. Evidence of cracking is also visible on the fracture surface of the embrittled specimen.

### Effect of Tensile Test Temperature

Tensile-test temperature as well as strain rate markedly influenced ductility. As is evident from figure 7, embrittlement was more pronounced at lower temperatures for a constant testing speed. For example, at 0.005 inch per minute (0.01 cm/min) embrittlement was quite severe at room temperature, as indicated by an elongation of only 5 percent. However, ductility gradually improved with increasing temperature until a maximum elongation of 19 percent was observed in the vicinity of 300° F (150° C). Similar temperature sensitivity was observed at the intermediate testing speed of 0.05 inch per minute (0.1 cm/min). These observations are remarkably similar to the mechanical behavior resulting from the well-known phenomenon of slow-strain-rate hydrogen embrittlement in titanium alloys and steels, which is discussed in the following section. Limited data reported by the General Electric Co. (private communication from L. P. Jahnke) indicated some apparent strain-rate and temperature sensitivity after exposure



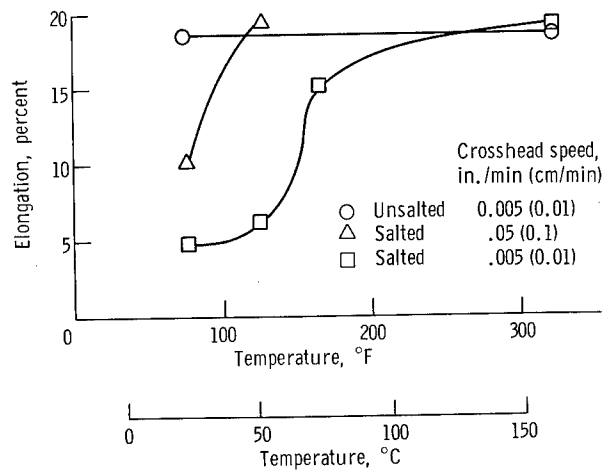

Figure 7. - Effect of tensile testing temperature on the ductility of Ti-8Al-1Mo-1V alloy specimens after salting and exposure at 800° F (425° C) for 100 hours at 50 000 psi (350 MN/m<sup>2</sup>).

of a titanium alloy to conditions conducive to hot-salt stress-corrosion.

## [ Hydrogen Embrittlement in Titanium Alloys ] → 12

The mechanical properties of titanium alloys can be drastically influenced by small concentrations of hydrogen (refs. 15 to 18). Embrittlement by hydrogen is manifested in two distinct types, designated slow-strain-rate embrittlement and impact embrittlement.

Impact embrittlement is known to be due to the thermal precipitation of hydrides and is most severe in  $\alpha$  alloys. Embrittlement becomes more severe in the presence of a notch, at lower temperatures, faster strain rates, and increasing hydrogen contents (refs. 15 and 16). This behavior is analogous to the classical problem of an increased ductile-brittle transition temperature.

Slow-strain-rate embrittlement occurs at hydrogen contents less than that required for the thermal precipitation of hydrides and is most common in  $\alpha + \beta$  alloys, although it does occur in single-phase  $\alpha$  and  $\beta$  alloys. Severity of embrittlement increases at higher hydrogen contents, at slower strain rates, and in a temperature range near ambient (refs. 15 to 18).

Slow-strain-rate embrittlement is not completely understood, but it has been rationalized in terms of the diffusion-controlled segregation of hydrogen to preferred sites within the microstructure. At fast strain rates, no embrittlement is observed because a critical concentration of hydrogen has not had sufficient time to develop. Similarly, a critical concentration of hydrogen is not achieved at elevated temperatures. This is probably due to several factors, such as increased solubility and diffusion rate, which

tend to homogenize the hydrogen distribution. Of course, total hydrogen content influences both the strain rate and temperature ranges where embrittlement is maximized (ref. 15).

### Effect of Vacuum Annealing

If, indeed, the embrittlement observed in these tests is a manifestation of hydrogen embrittlement, then the phenomenon should be reversible by inserting a vacuum annealing treatment between the elevated temperature exposure of salted specimens and the subsequent tensile test. The beneficial effect of vacuum annealing salted and exposed titanium alloy specimens on subsequent ambient-temperature-delayed-failure propensity has been demonstrated (ref. 14).

The application of a vacuum annealing treatment at 1200° F (650° C) for 24 hours resulted in full recovery of elongation and other tensile properties of a salted and exposed specimen (see table I) tested at the most sensitive conditions (ambient temperature and at the slowest strain rate). The elongation of a salted and exposed plus vacuum-annealed specimen was restored to 18 percent, compared with 5-percent elongation measured after salt exposure without vacuum annealing.

The observed reversibility indicates that little or no permanent damage, such as cracking, occurred during the elevated temperature salt exposure. Metallographic examination of all salted and exposed specimens confirmed that cracks did not develop during the elevated-temperature salt-exposure conditions. Of course, exposure under more severe embrittling conditions, such as increased salt concentrations, higher stress levels, and/or longer exposure times, could result in permanent damage, that is, cracking, during exposure. Hence, in these cases complete reversibility would not be expected. In fact, the one stress-rupture failure observed in this investigation confirms that severe exposure conditions could, indeed, induce substantial permanent damage during exposure.

### Hydrogen Analyses

In an effort to confirm that hydrogen is the damaging species, vacuum fusion gas analyses were conducted on specimens in several conditions (see table II). As is evident from these analyses, elevated temperature exposure of salted specimens resulted in increases in the hydrogen content of the material immediately adjacent to the fracture surface. Specifically, increases up to 126 ppm were measured after the standard 100-hour exposure condition, as compared with the as-received value of 70 ppm. Substantial



TABLE II. - HYDROGEN ANALYSES<sup>a</sup>

Specimen condition	Hydrogen content, ppm by wt
As-received <sup>b</sup>	70
As-received	55 to 89
Salted <sup>c</sup> and exposed <sup>d</sup>	100 to 126
Salted and stress rupture <sup>e</sup>	189 to 255
Salted, exposed, and vacuum annealed <sup>f</sup>	6 to 8

<sup>a</sup>Analyses obtained in regions near fracture surfaces.

<sup>b</sup>Vendor's analysis.

<sup>c</sup>0.2 mg/in.<sup>2</sup> (0.03 mg/cm<sup>2</sup>).

<sup>d</sup>800° F (425° C) at 50 000 psi (350 MN/m<sup>2</sup>) for 100 hr.

<sup>e</sup>800° F (425° C) at 80 000 psi (550 MN/m<sup>2</sup>) for 285 hr.

<sup>f</sup>1200° F (650° C) at <10<sup>-3</sup> torr for 24 hr.

increases to 255 ppm resulted after exposure to the more severe conditions of 800° F (425° C) at 80 000 psi (550 MN/m<sup>2</sup>). These severe exposure conditions induced a brittle failure during the stress-rupture test after 285 hours.

As expected, the hydrogen content of salted and exposed material was dramatically lowered by vacuum annealing. Typical analyses in the range of 7 ppm were measured after salting and exposure followed by vacuum annealing.

These results imply that hydrogen was generated by chemical reactions occurring during the elevated-temperature, salt-exposure conditions and that the base material picked up some of the hydrogen. A previous attempt to measure increases in hydrogen contents after salt exposure of a titanium alloy proved unsuccessful (ref. 14). In fact, early attempts in the present investigation were also unsuccessful because the specimens selected for analysis were so large that local increases in hydrogen contents could not be detected. Furthermore, the local hydrogen concentrations at internal interfaces and crack tips may even be substantially in excess of the values determined in this investigation. Thus, it is feasible that very high local concentrations of hydrogen could be promoting the embrittlement observed after hot-salt stress-corrosion exposure. In this regard, it should be noted that another investigator (ref. 20) has observed microsegregation of hydrogen at  $\alpha$ - $\beta$  grain boundaries and in the  $\beta$  phase with concentrations of 200 to 300 ppm in titanium alloys containing less than 50 ppm total hydrogen content.

### GENERAL REMARKS

The results of this investigation lend credence to the previously proposed (refs. 9 and 14) hydrogen-embrittlement concept for titanium alloy hot-salt stress-corrosion.

Specifically, the observed strain-rate and temperature sensitivity exhibited by salted and exposed material suggests that a diffusible species, such as hydrogen, is controlling the embrittlement process. The complete reversibility and recovery of ductility after vacuum annealing further substantiates the concept of hydrogen embrittlement. In addition, chemical analyses have confirmed increases in hydrogen content in the vicinity of the fracture surfaces of embrittled specimens after salt-exposure.

It is important to note that the brittle failure observed during the stress-rupture test at 800° F (425° C) may also be compatible with the temperature and strain-rate sensitivity discussed previously. Since extremely low strain rates ( $10^{-6}$  in./in./min) would be expected during this static-loading condition, this test could be represented in figure 7 as a point on another of the family of curves exhibiting embrittlement as a function of temperature and strain rate. Thus, hydrogen may also be the embrittling agent in the 500° to 900° F (260° to 480° C) temperature range where hot-salt stress-corrosion threshold tests are conducted. Further tests are required to establish the validity of this concept, however.

It has also been demonstrated that some of the differences in the threshold curves reported for titanium alloys may be due to testing variables. The degree of test sensitivity markedly influences the criteria that must be chosen for determining embrittlement. Thus, sensitivity increases at ambient temperature as the testing speed decreases to 0.005 inch per minute (0.01 cm/min). Extending this concept still further, the ultimate in test sensitivity may well be some type of delayed failure or stress-rupture test, perhaps with notched specimens. Although this investigation was concerned with the Ti-8Al-1Mo-1V alloy, similar behavior would be expected with other  $\alpha + \beta$  titanium alloys. Again, additional studies are needed to establish whether similar effects will be exhibited by single-phase  $\alpha$  and  $\beta$  alloys.

## SUMMARY OF RESULTS

The hypothesis that hydrogen is the cause of the embrittlement observed in titanium alloys after exposure to conditions conducive to hot-salt stress-corrosion was investigated. The effects of tensile strain rate and test temperature after such exposure were determined for the titanium - 8-aluminum - 1-molybdenum - 1-vanadium alloy after the specimens were coated with salt and exposed at elevated temperature while being stressed.

1. Embrittlement was more severe as the tensile testing speed (strain rate) decreased. Salted and exposed specimens exhibited no loss of elongation at a fast cross-head speed of 0.5 inch per minute (1 cm/min), but similarly salted and exposed specimens revealed a decrease in tensile elongation from 19 to 5 percent when tested at a slow

crosshead speed of 0.005 inch per minute (0.01 cm/min).

2. Embrittlement was more pronounced when salted and exposed specimens were tensile tested at lower temperatures for a constant testing speed. Specimens tested at 0.005 inch per minute (0.01 cm/min) exhibited an elongation of 5 percent at ambient temperature and a gradual improvement in ductility with increasing test temperature until a maximum elongation of 19 percent was observed in the vicinity of 300<sup>o</sup> F (150<sup>o</sup> C).

3. Vacuum annealing of salted and exposed specimens at 1200<sup>o</sup> F (650<sup>o</sup> C) for 24 hours at less than 10<sup>-3</sup> torr (0.13 N/m<sup>2</sup>) resulted in essentially complete recovery of ductility in subsequent tensile tests conducted at ambient temperature and at a crosshead speed of 0.005 inch per minute (0.01 cm/min).

4. Increased hydrogen contents were measured in salted and exposed samples from areas immediately adjacent to the fracture surfaces of embrittled specimens. The values ranged to 255 ppm compared with 70 ppm for the as-received material. Vacuum annealing reduced the hydrogen content to about 7 ppm for salted and exposed specimens. *J. E. L.*

Lewis Research Center,  
National Aeronautics and Space Administration,  
Cleveland, Ohio, October 31, 1968,  
129-03-06-05-22.

## REFERENCES

1. Turley, R. V.; and Avery, C. H.: Elevated-Temperature Static and Dynamic Sea-Salt Stress Cracking of Titanium Alloys. Stress-Corrosion Cracking of Titanium. Spec. Tech. Publ. No. 397, ASTM, 1966, pp. 1-30.
2. Piper, D. E.; and Fager, D. N.: The Relative Stress-Corrosion Susceptibility of Titanium Alloys in the Presence of Hot Salt. Stress-Corrosion Cracking of Titanium. Spec. Tech. Publ. No. 397, ASTM, 1966, pp. 31-52.
3. Simenz, R. F.; Van Orden, J. M.; and Wald, G. G.: Environmental Effects Studies on Selected Titanium Alloys. Stress-Corrosion Cracking of Titanium. Spec. Tech. Publ. No. 397, ASTM, 1966, pp. 53-79. *J. E. L.*
4. Donachie, M. J., Jr.; Danesi, W. P.; and Pinkowish, A. A.: Effects of Salt Atmosphere on Crack Sensitivity of Commercial Alloys at 600 to 900 F. Stress-Corrosion Cracking of Titanium. Spec. Tech. Publ. No. 397, ASTM, 1966, pp. 179-193.

5. Heimerl, G. J.; Braski, D. N.; Royster, D. M.; and Dexter, H. B.: Salt Stress Corrosion of Ti-8Al-1Mo-1V Alloy Sheet at Elevated Temperatures. Stress-Corrosion Cracking of Titanium. Spec. Tech. Publ. No. 397, ASTM, 1966, pp. 194-214.
6. Logan, H. L.; McBee, M. J.; Bechtoldt, C. J.; Sanderson, B. T.; and Ugiansky, G. M.: Chemical and Physical Mechanisms of Salt Stress-Corrosion Cracking in the Titanium 8-1-1 Alloy. Stress-Corrosion Cracking of Titanium. Spec. Tech. Publ. No. 397, ASTM, 1966, pp. 215-229.
7. Petersen, V. C.; and Bomberger, H. B.: The Mechanism of Salt Attack on Titanium Alloys. Stress-Corrosion Cracking of Titanium. Spec. Tech. Publ. No. 397, ASTM, 1966, pp. 80-94.
8. Hatch, A. J.; Rosenberg, H. W.; and Erbin, E. F.: Effects of Environment on Cracking in Titanium Alloys. Stress-Corrosion Cracking of Titanium. Spec. Tech. Publ. No. 397, ASTM, 1966, pp. 122-136.
9. Rideout, S. P.; Louthan, M. R., Jr.; and Selby, C. L.: Basic Mechanisms of Stress-Corrosion Cracking of Titanium. Stress-Corrosion Cracking of Titanium. Spec. Tech. Publ. No. 397, ASTM, 1966, pp. 137-151.
10. Dexter, Howard B.: Salt Stress Corrosion of Residually Stressed Ti-8Al-1Mo-1V Alloy Sheet after Exposure at Elevated Temperatures. NASA TN D-3299, 1966.
11. Stone, L. H.; and Freedman, A. H.: Cyclic Hot-Salt Stress Corrosion of Titanium Alloys. Rep. NOR-67-151, Northrop Corp. (AFML-TR-67-289), Sept. 1967. (Available from DDC as AD-825239.)
12. Braski, David N.: Preliminary Investigation of Effect of Environmental Factors on Salt Stress Corrosion Cracking of Ti-8Al-1Mo-1V at Elevated Temperatures. NASA TM X-1048, 1964.
13. Ashbrook, Richard L.: A Survey of Salt Deposits in Compressors of Flight Gas Turbine Engines. NASA TN D-4999, 1968.
14. Lingwall, R. G.; and Ripling, E. J.: Elevated Temperature Stress Corrosion of High Strength Sheet Materials in the Presence of Stress Concentrators. Material Research Lab., Inc. (NASA CR-88979), Aug. 1967.
15. Williams, D. N.: The Hydrogen Embrittlement of Titanium Alloys. J. Inst. Metals, vol. 91, 1962-1963, pp. 147-152.
16. Cotterill, P.: The Hydrogen Embrittlement of Metals. Progress in Materials Science, Vol. 9, No. 4. Pergamon Press, 1961, pp. 241-259.

17. Robinson, H. A.; Frost, P. D.; and Parris, W. M.: Effect of Hydrogen on Some Mechanical Properties of a Titanium Alloy Heat-Treated to High Strength. Trans. AIME, vol. 212, no. 4, Aug. 1958, pp. 464-469.
18. Daniels, R. D.; Quigg, R. J.; and Troiano, A. R.: Delayed Failure and Hydrogen Embrittlement in Titanium. Case Inst. Tech. (WADC TR 58-39). Feb. 1958. (Available from DDC as AD-142314.)
19. Boyd, W. K.; and Fink, F. W.: The Phenomenon of Hot-Salt Stress-Corrosion Cracking of Titanium Alloys. NASA CR-117, 1964.
20. Tiner, N. A.; Mackay, T. L.; Asunmaa, S. K.; and Ingersoll, R. G.: Use of Electron Microautoradiography for Evaluating Microsegregation of Hydrogen in Titanium Alloys. ASM Trans. Quarterly, vol. 61, no. 2, June 1968, pp. 195-202.

NATIONAL AERONAUTICS AND SPACE ADMINISTRATION  
WASHINGTON, D. C. 20546  
OFFICIAL BUSINESS

POSTAGE AND FEES PAID  
NATIONAL AERONAUTICS AND  
SPACE ADMINISTRATION

FIRST CLASS MAIL

050 001 42 55 4ES 69046 68013 01195  
BATTELLE MEMORIAL INSTITUTE  
DEFENSE METALS INFORMATION CENTER  
COLUMBUS LABORATORIES  
505 KING AVE.  
COLUMBUS, OHIO 43201  
ATT ROGER J. RUNCK

POSTMASTER: If Undeliverable (Section 158  
Postal Manual) Do Not Return

*"The aeronautical and space activities of the United States shall be conducted so as to contribute . . . to the expansion of human knowledge of phenomena in the atmosphere and space. The Administration shall provide for the widest practicable and appropriate dissemination of information concerning its activities and the results thereof."*

— NATIONAL AERONAUTICS AND SPACE ACT OF 1958

## NASA SCIENTIFIC AND TECHNICAL PUBLICATIONS

**TECHNICAL REPORTS:** Scientific and technical information considered important, complete, and a lasting contribution to existing knowledge.

**TECHNICAL NOTES:** Information less broad in scope but nevertheless of importance as a contribution to existing knowledge.

**TECHNICAL MEMORANDUMS:** Information receiving limited distribution because of preliminary data, security classification, or other reasons.

**CONTRACTOR REPORTS:** Scientific and technical information generated under a NASA contract or grant and considered an important contribution to existing knowledge.

**TECHNICAL TRANSLATIONS:** Information published in a foreign language considered to merit NASA distribution in English.

**SPECIAL PUBLICATIONS:** Information derived from or of value to NASA activities. Publications include conference proceedings, monographs, data compilations, handbooks, sourcebooks, and special bibliographies.

**TECHNOLOGY UTILIZATION PUBLICATIONS:** Information on technology used by NASA that may be of particular interest in commercial and other non-aerospace applications. Publications include Tech Briefs, Technology Utilization Reports and Notes, and Technology Surveys.

*Details on the availability of these publications may be obtained from:*

SCIENTIFIC AND TECHNICAL INFORMATION DIVISION  
NATIONAL AERONAUTICS AND SPACE ADMINISTRATION  
Washington, D.C. 20546