

**AFRL-ML-WP-TR-2000-4120**

**C-130 FLIGHT CONTROL SURFACES  
DEPAINT PROCESS OPTIMIZATION**



**CHARLES H. CUNDIFF  
JANET BUCKINGHAM**

**SOUTHWEST RESEARCH INSTITUTE -- DAYTON  
P.O. BOX 31009  
DAYTON, OHIO 45437**

**DECEMBER 1999**

**FINAL REPORT FOR 09/01/1997 - 12/31/1999**

**APPROVED FOR PUBLIC RELEASE; DISTRIBUTION UNLIMITED**

**MATERIALS AND MANUFACTURING DIRECTORATE  
AIR FORCE RESEARCH LABORATORY  
AIR FORCE MATERIEL COMMAND  
WRIGHT-PATTERSON AIR FORCE BASE OH 45433-7750**

**20001004 052**

## NOTICE

*Using Government drawings, specifications, or other data included in this document for any purpose other than Government procurement does not in any way obligate the U.S. Government. The fact that the Government formulated or supplied the drawings, specifications, or other data does not license the holder or any other person or corporation; or convey any rights or permission to manufacture, use, or sell any patented invention that may relate to them.*

*This report is releasable to the National Technical Information Service (NTIS). At NTIS, it will be available to the general public, including foreign nations.*

**THIS TECHNICAL REPORT HAS BEEN REVIEWED AND IS APPROVED FOR PUBLICATION.**



BARNARD T. GHIM, MAJ USAF  
Project Engineer  
Coatings Technology Integration Office  
Logistics Systems Support Branch  
Systems Support Division

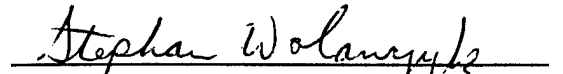

STEPHAN M. WOLANCZYK  
Acting Chief  
Logistics Systems Support Branch  
Systems Support Division

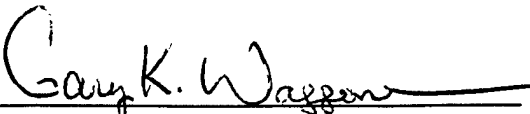

GARY K. WAGGONER  
Chief  
System Support Division  
Materials & Manufacturing Directorate

*Do not return copies of this report unless contractual obligations or notice on a specific document requires its return.*

REPORT DOCUMENTATION PAGE			Form Approved OMB No. 0704-0188	
Public reporting burden for this collection of information is estimated to average 1 hour per response, including the time for reviewing instructions, searching existing data sources, gathering and maintaining the data needed, and completing and reviewing the collection of information. Send comments regarding this burden estimate or any other aspect of this collection of information, including suggestions for reducing this burden, to Washington Headquarters Services, Directorate for Information Operations and Reports, 1215 Jefferson Davis Highway, Suite 1204, Arlington, VA 22202-4302, and to the Office of Management and Budget, Paperwork Reduction Project (0704-0188), Washington, DC 20503.				
1. AGENCY USE ONLY (Leave blank)	2. REPORT DATE DECEMBER 1999	3. REPORT TYPE AND DATES COVERED FINAL REPORT FOR 09/01/1997 - 12/31/1999		
4. TITLE AND SUBTITLE C-130 FLIGHT CONTROL SURFACES DEPAINT PROCESS OPTIMIZATION			5. FUNDING NUMBERS C F046006-95-D-0176-RZ01	
6. AUTHOR(S) CHARLES H. CUNDIFF JANET BUCKINGHAM				
7. PERFORMING ORGANIZATION NAME(S) AND ADDRESS(ES) SOUTHWEST RESEARCH INSTITUTE -- DAYTON P.O. BOX 31009 DAYTON, OHIO 45437			8. PERFORMING ORGANIZATION REPORT NUMBER	
9. SPONSORING/MONITORING AGENCY NAME(S) AND ADDRESS(ES) MATERIALS AND MANUFACTURING DIRECTORATE AIR FORCE RESEARCH LABORATORY AIR FORCE MATERIEL COMMAND WRIGHT-PATTERSON AFB, OH 45433-7750 POC: MAJOR BERNARD T. GHIM, AFRL/MLSSO, 937-255-0943			10. SPONSORING/MONITORING AGENCY REPORT NUMBER  AFRL-ML-WP-TR-2000-4120	
11. SUPPLEMENTARY NOTES				
12a. DISTRIBUTION AVAILABILITY STATEMENT  APPROVED FOR PUBLIC RELEASE, DISTRIBUTION UNLIMITED.			12b. DISTRIBUTION CODE	
13. ABSTRACT (Maximum 200 words)  Southwest Research Institute, acting on behalf of the Air Force Coating Technology Integration Office (CTIO), has conducted a test program of a plastic media blast (PMB) process proposed by Ogden Air Logistics Center (OO-ALC) for coatings removal on substrates consisting of spot welded, thin alloy materials. Specifically, the substrates under consideration for this assessment are C-130 flight control surfaces, and are fabricated with 0.016 inch, 2024-T3, clad aluminum.				
14. SUBJECT TERMS Plastic Media Blast, Coatings Removal, Substrates, Spot Welded			15. NUMBER OF PAGES 93	
			16. PRICE CODE	
17. SECURITY CLASSIFICATION OF REPORT  UNCLASSIFIED	18. SECURITY CLASSIFICATION OF THIS PAGE  UNCLASSIFIED	19. SECURITY CLASSIFICATION OF ABSTRACT  UNCLASSIFIED	20. LIMITATION OF ABSTRACT  SAR	

## TABLE OF CONTENTS

EXECUTIVE SUMMARY .....	iv
1.0 INTRODUCTION .....	1
2.0 BACKGROUND .....	1
3.0 APPROACH .....	1
4.0 RESULTS .....	3
5.0 DISCUSSION/RECOMMENDATIONS .....	4
APPENDIX A Metcut Test Data	
Lab Report 1: High Cycle Fatigue Testing	
Lab Report 2: Tensile Testing	
APPENDIX B Statistical Analysis of Low Cycle Fatigue and Spot Weld Strength Tests	
APPENDIX C OO-ALC C-130 Flight Control and Thin Skin Plastic Media Blast Process	

## EXECUTIVE SUMMARY

<b>Title:</b>	C-130 Flight Control Surfaces Depaint Process Optimization
<b>AF Customer:</b>	Ogden Air Logistics Center
<b>Report Period:</b>	September 1997-December 1999

### 1.0 Introduction

Southwest Research Institute, acting on behalf of the Air Force Coatings Technology Integration Office (CTIO), has conducted a test program of a plastic media blast (PMB) process proposed by Ogden Air Logistics Center (OO-ALC) for coatings removal on substrates consisting of spot welded, thin alloy materials. Specifically, the substrates under consideration for this assessment are C-130 flight control surfaces, and are fabricated with 0.016 inch, 2024-T3, clad aluminum. The PMB process proposed for this purpose by OO-ALC is based on Type V (MIL-P-85891A) blast media.

### 2.0 Approach

PMB process/materials characterizations for this project were coordinated between OO-ALC and the C-130 SPD (WR-ALC/LBR), and were designed to produce an evaluation of possible PMB imposed changes to material and structural (i.e., spot welded components) properties. The tests that were conducted address these and other possible PMB produced effects on thin (0.016 inch) spot welded structures and face sheet materials. These evaluations included low cycle fatigue of the face sheet materials, low cycle fatigue of spot welded structures, spot weld shear strength, and spot weld tensile strength. In addition, other data were developed to obtain C-130 SPD approval. These data consisted of qualitative residual stress measurements (aero Almen measurements), and surface roughness measurements.

### 3.0 Results

Statistical and comparative analysis of the materials/structural test data indicated no degradation produced by the OO-ALC PMB process in regard to the majority of the assessments conducted in this project. This includes all aspects of testing of the spot welded materials/structures, and most of the assessments of the PMB process effects on substrate materials. The single exception to the preceding statements regarding materials degradation was that the analysis of the face sheet material low cycle fatigue data sets indicated a reduction of 25% between the control materials and the materials conditioned by 4 zero dwell blast cycles at the normal standoff distance. This difference was determined to be statistically significant.

#### **4.0 Conclusions/Recommendations**

The data, and subsequent results, developed within the context of this project indicated that the OO-ALC PMB process is generally in compliance with the acceptance criteria set forth by the C-130 SPD with one exception. In the majority of the characterizations of the OO-ALC PMB process conducted by this study, the process has manifested quite acceptable results with the noted exception due solely to the results of one portion of the low cycle fatigue testing for the face sheet materials.

On the basis of the data developed by this study, CTIO recommended that OO-ALC pursue gaining C-130 SPD approval regardless of the low cycle fatigue data. Considering that a realistic appraisal by the C-130 SPD regarding overall aircraft integrity could easily determine that the difference of fatigue life seen within this study for one variation of the PMB process are not significant. The test results for parameters that are more likely to be pertinent regarding aircraft integrity, such as spot weld reliability, residual stresses, and surface profile indicated an acceptable PMB process per the Test Plan and acceptance criteria associated with this study.

The process evaluated by this project was subsequently approved for use by the C-130 SPD. The parameters and certain quality assurance measures resulting from this assessment have been incorporated into an OO-ALC process specification used for the depaint operations on the C-130 flight control surfaces.

## 1.0 INTRODUCTION

Ogden Air Logistics Center (OO-ALC) identified a technical requirement for a study to assess a Plastic Media Blasting (PMB) process for use on very thin substrate materials and structures. The responsibility for project management for this effort was tasked to the Air Force Coatings Technology Integration Office (CTIO). This project addressed technical requirements regarding the OO-ALC PMB process utilizing Type V (acrylic) media on thin aluminum alloy substrate and structures.

## 2.0 BACKGROUND

The C-130 System Program Directorate (SPD) has previously approved a Type V media PMB process for use on most of the aircraft surfaces. However, before complete SPD process approval can be gained to include application on thin substrate and structural materials (0.016 inch), additional test data had to be developed. Such data has been developed under this project and is discussed below.

## 3.0 APPROACH

PMB process and materials characterizations used for this project were coordinated between the C-130 SPD (WR-ALC/LBR) and OO-ALC. The characterizations used in this project were designed to produce an evaluation of possible PMB imposed changes to material and structural (i.e., spot welded components) properties. The tests that were conducted address these and other possible PMB produced effects on thin (0.016 inch) spot welded structures and face sheet materials. These evaluations included:

1. Low Cycle Fatigue IAW the Draft Air Force Engineering Qualification Plan (EQP) for Coatings/Paint Removal Techniques, for the face sheet material and the Welding Institute Standard Methods for spot welds:
  - A. Face Sheet: A mean low cycle fatigue life of the face sheet materials in an as-received condition (before the PMB process is applied) was determined, and was used to compare with similar data developed with blasted test materials to determine possible PMB blast imparted effects on these materials. (See Figure 1 for specimen dimensions.)
  - B. Spot Welds: The design of this test and specimen determined the fatigue characteristics of the spot weld bonds, i.e., the integrity of the welded structure as may be affected by failure of spot welds. This data is used to determine, by comparison with blasted materials, how the OO-ALC PMB process may possibly affect this characteristic. (See Figure 2 for an illustration of the sheet weld layout, and the final specimen dimensions.)

Test parameters for the low cycle fatigue tests were developed to produce a low cycle fatigue life in the baseline tests of 100,000 fatigue cycles, nominal. All low cycle fatigue specimens were tested at laboratory ambient temperature in a closed loop servo controlled hydraulic test frame, with a constant stress ratio of  $R=0.1$ , and at a frequency of 10 Hz. Baseline test materials received no conditioning other than that associated with fabrication of the test

specimens. Experimental test materials were conditioned only by application of the specified Type V PMB process to the equivalent of four (4) blast cycles<sup>1</sup>. No coating system was applied to any of the materials used for this evaluation. Therefore, all conditioned materials were blasted as machined, and/or fabricated.

2. Tensile-Shear Strength IAW Welding Institute Standard Methods for spot welds. (See Figure 2 for final specimen dimensions.)
3. Tensile Strength IAW Welding Institute Standard Methods for spot welds. (See Figure 3 for spot weld tensile specimen dimensions.)

In order to obtain C-130 SPD approval of the OO-ALC PMB process other data were developed which included:

1. Qualitative residual stress measurements (aero Almen measurements)
2. Surface roughness measurements.

The test data developed for this project are tabulated and presented in Tables 1 through 7. All test data provided by the test laboratory, Metcut Research, Inc., are given in Appendix A. All materials testing was conducted IAW the Draft Air Force EQP or the Welding Institute Standard Methods, dependent on the nature of the test. Various degrees of PMB process aggressiveness, such as increased blast dwell and decreased standoff distances, were used for conditioning test materials. This approach was IAW the request of the C-130 SPD, and the parameters applied for specimen conditioning are noted in the data tables. The normal or typical PMB process parameters used in this project were as follows:

Media	Type V, 20/30 mesh
Blast angle	45° to the plane of the test panel
Blast direction	90° to the roll direction of the test panel/specimen
Pressure	25 psi
Media flow rate	≈ 480 lb/hr
Standoff distance (SOD)	24 inches measured from the tip of the blast nozzle to the surface of the test panel/specimen.

Specimen conditioning (blasting) was done by manual application. A qualified blast technician applied the PMB process per parameters specified by the coordinated test plan. A small cross beam-like structure (Figure 4) was used to give the operator a reference frame for blast angle and SOD, thus providing some means of controlling these parameters. The rate at which the blast stream was traversed over the substrate as "zero dwell" was based on a nominal strip rate of approximately 1 ft<sup>2</sup>/minute. This was established by assuming a blast footprint of 2.5 inches in diameter, and the traverse rate was then estimated to be 1 inch/second ≈ 1 ft<sup>2</sup>/minute. The blast footprint was determined through measurements made on other coated materials. Specimen preparations of spot welded materials were conducted IAW Lockheed-Georgia Specification STP55-005V01F (supercedes MIL-W-6858). X-ray examinations of spot welded materials were used to ensure weld integrity prior acceptance of the materials for testing.

---

<sup>1</sup> Each blast cycle was the equivalent of a zero dwell cycle as defined by OO-ALC operating procedures. A zero dwell cycle is determined as the blast time required to remove the coating system with no extra applied blasting.

## 4.0 RESULTS

Statistical and comparative analysis (See Appendix B for statistical analysis.) of the materials/structural test data indicated no degradation produced by the OO-ALC PMB process regarding the majority of the assessments conducted in this project. This includes all aspects of testing of the spot welded materials/structures, and most of the assessments of the PMB process effects on substrate materials.

Analysis of the spot weld (structural as defined by this project) data indicate no statistically significant differences between mean test values for control specimens, and for specimens conditioned with the PMB process for a variety of process parameters. These tests included evaluations of spot weld low cycle fatigue, spot weld tensile strength, and spot weld shear strength.

The tests/measurements for blast imparted residual stresses and surface roughness also indicated acceptable results per criteria cited by the C-130 SPD. The upper limit set for acceptable Almen arc heights<sup>2</sup> was determined by the C-130 SPD to be 6 mils (0.006 inch), and all mean values for various blast conditions were below that threshold. Almen measurements were made IAW the EQP, which means that aero Almen specimens are of a thicker, bare alloy<sup>3</sup>.

An acceptable (i.e., typical to WR-ALC maintenance operations) surface roughness measurement was determined from measurements obtained from several aircraft stripped at WR-ALC with a water blast process, which is augmented by a bicarbonate-of-soda abrasive. Measurements on these aircraft were made at various locations that appeared to have more surface profile than other areas of the aircraft with the intent to determine some upper limit for surface roughness. A median value for  $R_a = 175 \mu\text{inch}$  was derived from the range of measurements made at these different locations. The surface roughness measurements developed for the OO-ALC PMB process were made on the same 0.016 inch, 2024-T3, clad materials used for most of the other tests conducted in this project. Measurements were made for several dwell times or blast cycles, and all measurements, regardless of the blast quantity/dwell, were below the 175- $\mu\text{inch}$  threshold.

There is one exception to the above statements regarding materials degradation within the context of the acceptance criteria cited by the Test Plan coordinated between OO-ALC/LAOE and the C-130 SPD for this appraisal. Analysis of the face sheet material low cycle fatigue data sets indicated a reduction of 13% between the control materials, and the materials conditioned by 4 zero dwell blast cycles at half the normal standoff distance. It was also determined that this difference is not statistically significant. However, it was determined that there is a statistically significant difference between the mean fatigue lives of the control specimens, and the specimens conditioned with the other variation of the PMB process. Test materials conditioned by 4 zero dwell blast cycles at the normal standoff distance exhibited a 25% reduction of the mean fatigue life as compared to the mean fatigue life for the control specimens.

---

2 Almen specimen arc heights measured before and after blasting provide qualitative residual stress measurements.

3 All tests for this study used 0.016 inch, 2024-T3 clad aluminum alloy as the substrate material, except for Almen testing, which are conducted with unpainted 0.032 inch, 2024-T3 bare aluminum alloy.

## 5.0 DISCUSSION/RECOMMENDATIONS

The data and subsequent results developed within the context of this project indicate that the OO-ALC PMB process is generally in compliance with acceptance criteria set forth by the C-130 SPD with one exception. In the majority of the characterizations of the OO-ALC PMB process conducted by this study, the process has manifested quite acceptable results with the noted exception due solely to the results of one portion of the low cycle fatigue testing for the face sheet materials.

Although the low cycle fatigue data for the face sheet materials *appear* to argue that the more aggressive PMB process parameters produced improved mean fatigue life in comparison with the standard PMB process, this can be misleading. Again, one should bear in mind that these data sets are not of sufficient size (quantity of discreet data points) to grant great confidence in such a meaningful conclusion, and it must also be considered that more aggressive process parameters could easily render the PMB process unacceptable in terms of increased residual stresses, surface roughness, and possibly other test parameters such as spot weld integrity.

On the basis of the data developed by this study, it was recommended that OO-ALC pursue gaining C-130 SPD approval<sup>4</sup> regardless of the low cycle fatigue data. The principal issues that were suggested for consideration in this approach are:

1. Will the C-130 SPD have a genuine concern regarding fatigue life for these areas/structures? Considering that it is not likely that a fatigue sensitive structure would be designed with materials this thin, it would seem that this is a crucial question. A realistic appraisal by the C-130 SPD regarding overall aircraft integrity could easily determine that the differences of fatigue life seen within this study for one variation of the PMB process are not significant.
2. The test results for parameters that are more likely to be pertinent such as spot weld integrity, residual stresses, and surface profile indicated an acceptable PMB process per the Test Plan coordinated for this study.

The overall reasoning to these arguments were that any attempts to develop a different PMB process would not necessarily produce any results exhibiting significant improvements in low cycle fatigue properties, and could easily produce unfavorable results in terms of more pertinent materials/structural properties.

---

<sup>4</sup> C-130 SPD approval has been given for use of the OO-ALC PMB process. SwRI has reviewed the Process Specification, modifications were suggested, and those modifications were incorporated. The Process Specification may be found in Appendix C.

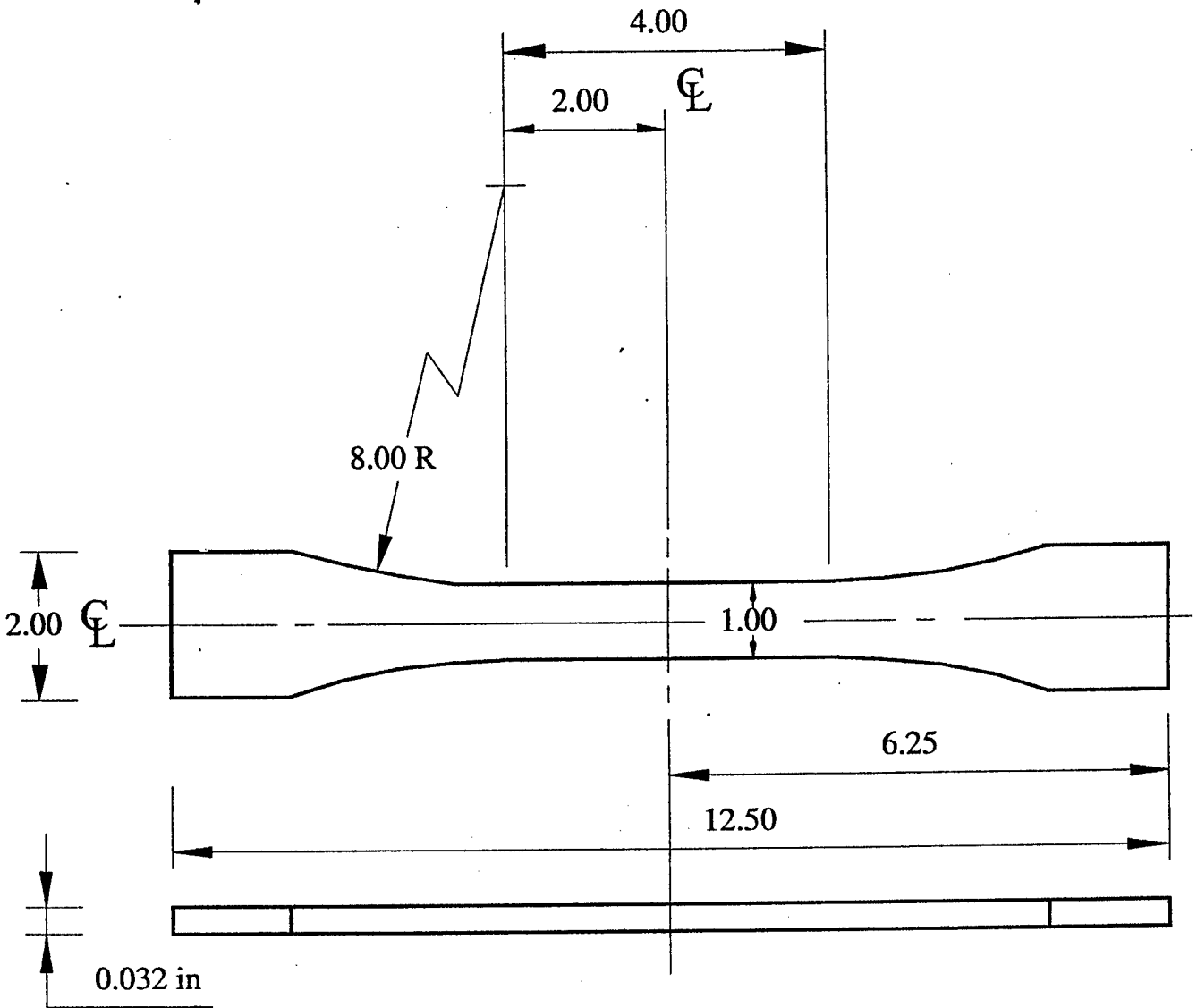

Figure 1. Face Sheet Low Cycle Fatigue Specimen

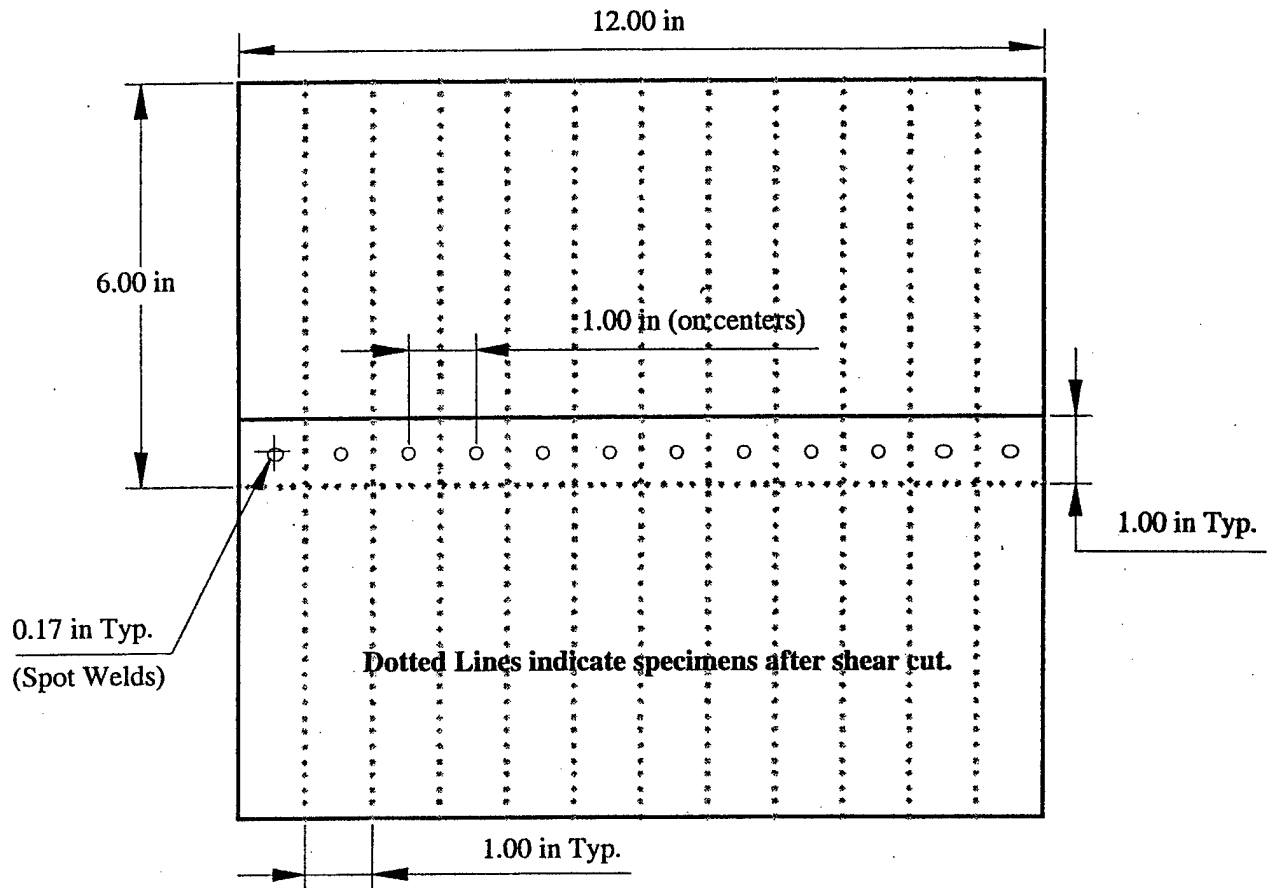

Figure 2. Sheet Weld Layout and Final Fatigue/Shear Specimen Dimensions.

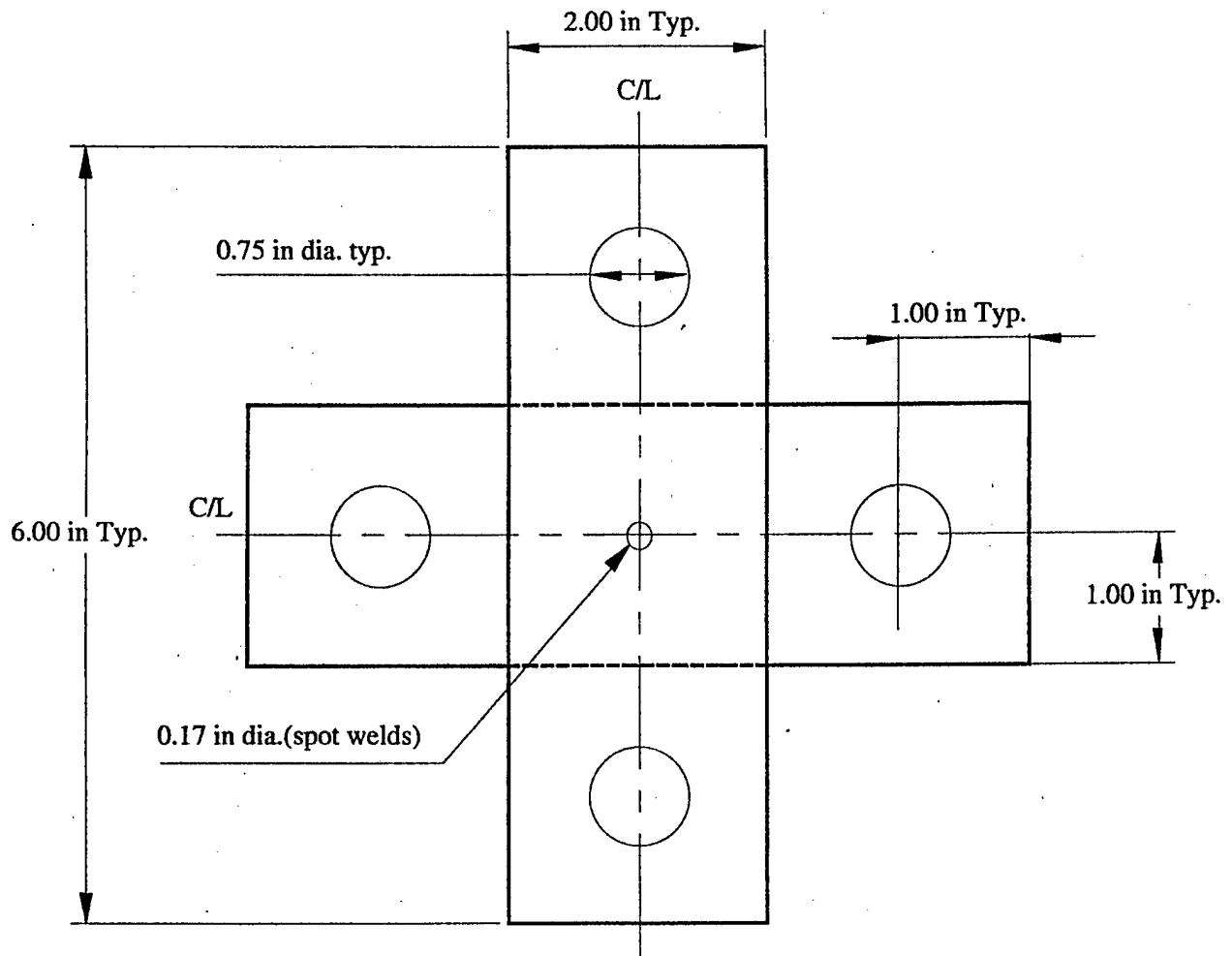

Figure 3. Spot Weld Tensile Specimen Layout and Dimensions



**Figure 4. Test materials conditioning guide.**

**Table 1. Qualitative Residual Stress Data for Various Dwell Periods (Arc Height, mils)**

OO-ALC PMB Data Set	1 Blast Cycle		2 Blast Cycles		3 Blast Cycles		4 Blast Cycles	
	Mean $\Delta H$ , mils	StDev, mils	Mean $\Delta H$ , mils	StDev, mils	Mean $\Delta H$ , mils	StDev, mils	Mean $\Delta H$ , mils	StDev, mils
#1	1.86	0.71	2.70	1.18	3.34	1.17	4.24	0.92
#2	2.32	0.74	N/A	N/A	N/A	N/A	3.34	0.69
#3	1.98	0.60	N/A	N/A	N/A	N/A	4.62	1.51

Note: Each data set consists of 5 specimens blasted using OO-ALC PMB process for flight control surfaces. Data for 2 and 3 blast cycles was not required by the test plan, and some data were developed for information only.

**Table 2. Qualitative Residual Stress Data for Various Process Conditions to Determine Process Tolerances**

Process Condition	+5 psi Pressure	+10 psi Pressure	12 in SOD	14 in SOD	16 in SOD	18 in SOD
Mean $\Delta H$ , mils	3.66	3.54	3.50	3.76	2.68	3.26
StDev, mils	0.42	0.59	0.42	0.88	0.51	0.57

Note: Data sets consist of 5 specimens blasted 1 cycle. Normal OO-ALC PMB process for flight controls is blast pressure of 25 psi, and standoff distance (SOD) = 24 inches.

**Table 3. Surface Roughness Measurements after Various Blast Cycles/Dwell Periods**

OO-ALC PMB Process	1 Cycle		2 Cycles		3 Cycles		4 Cycles		
	R <sub>a</sub>	StDev	R <sub>a</sub>	StDev	R <sub>a</sub>	StDev	R <sub>a</sub>	StDev	
Panel 1	Area 1	49.4	3.6	64.3	4.6	61.7	4.8	71.3	3.8
	Area 2	67.1	3.7	65.4	2.3	74.1	4.9	73.8	4.0
Panel 2	Area 1	56.0	5.0	73.4	4.1	74.6	5.2	68.6	5.9
	Area 2	66.3	3.1	69.8	3.2	66.5	6.6	70.9	1.9
Panel 3		72.6	11.5	75.9	10.7	67.9	9.5	78.8	8.8
Panel 4		67.4	10.6	62.6	7.9	70.3	10.1	67.8	8.7

**Table 4. Spot Weld Shear Strength Test Results**

Condition	Data #1 Load, lbs	Data #2 Load, lbs	Data #3 Load, lbs	Data #4 Load, lbs	Data #5 Load, lbs	Mean Value Load, lbs	StDev ±
As Received	233	227	208	232	239	228	11.9
0 Dwell, Normal SOD	240	239	244	235	248	241	5.0
0 Dwell, 1/2 SOD	226	249	243	246	253	243	10.4
0 Dwell, 1/3 SOD	229	242	249	233	249	240	9.2
2x Dwell, N SOD	254	252	240	228	233	241	11.4

**Table 5. Spot Weld Tensile Strength Test Results**

Condition	Data #1 Load, lbs	Data #2 Load, lbs	Data #3 Load, lbs	Data #4 Load, lbs	Data #5 Load, lbs	Mean Value Load, lbs	StDev ±
As Received	71	68	63	68	66	67	2.9
0 Dwell, Normal SOD	74	75	73	68	68	72	3.4
0 Dwell, 1/2 SOD	62	68	77	74	57	68	8.3
0 Dwell, 1/3 SOD	55	72	73	72	n/a <sup>1</sup>	68	8.7
2x Dwell, N SOD	67	69	68	74	65	69	3.4

<sup>1</sup> - Flawed spot weld, no data point.

**Table 6. Spot Weld Fatigue Data, n Cycles to Failure**

Specimen	Control	4xDwell/NSOD	4xDwell/.5SOD
01	98,861	21,655	100,016
02	99,031	100,031	131,314
03	143,702	50,763	66,498
04	58,346	106,229	100,009
05	60,490	61,144	86,851
06	78,478	68,959	159,818
07	110,886	107,358	142,833
08	36,429	83,304	100,594
09	45,148	159,878	103,717
10	49,537	100,860	123,240
11	45,122		
12	107,358		
<b>Mean</b>	<b>77,782</b>	<b>86,018</b>	<b>111,489</b>
<b>StDev</b>	<b>33,749</b>	<b>38,062</b>	<b>27,735</b>

**Table 7. Face Sheet Fatigue Data, n Cycles to Failure**

Specimen	Control	4xDwell/NSOD	4xDwell/.5SOD
01	88,343	36,584	82,998
02	67,237	67,527	76,923
03	74,111	80,355	84,479
04	101,700	77,450	69,337
05	76,676	44,999	94,511
06	83,929	49,075	50,500
07	94,228	72,499	71,024
08	87,327	91,650	68,562
09	100,758	61,220	88,300
10	77,394		60,264
11	93,755		
<b>Mean</b>	<b>85,951</b>	<b>64,595</b>	<b>74,690</b>
<b>StDev</b>	<b>11,216</b>	<b>18,157</b>	<b>13,420</b>

**APPENDIX A**  
METCUT TEST DATA

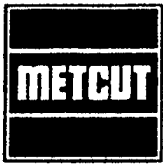

# LABORATORY REPORT

To: Southwest Research Institute  
ATTN: Vince Krausey  
Post Office Drawer 28510  
San Antonio, TX 78284

Project No.: 635-69997-2  
Date: December 9, 1998  
Authorization: 63541

Project : High Cycle Fatigue Testing of (76) Aluminum Alloy 2024-T3 Clad Sheet Specimens  
Supplied and Identified by AF CTIO.

Material Identity: Face Sheet & Spot Welded Al 2024-T3 Clad Sheet  
Test Specification: ASTM E466 & CTIO Instructions  
Drawing Number: MRI 981008-1 and Lap Shear Geometry  
Machining Finish: Low Stress Ground and Polished  
(Lap Shear specimens were sheared from spot welded sheets.)

## Test Conditions

Mode: Axial Load Control  
Temperature: 75°F  
Stress Ratio:  $R = 0.1$   
Frequency: 10 Hz.  
Waveform: Sinusoidal  
Test Machine: Closed Loop Servo Controlled Hydraulic System of 20 kip Capacity  
(LCF No. 60017 and 60073)

Test data is summarized in Tables I, II, III, IV, V, VI and VII.

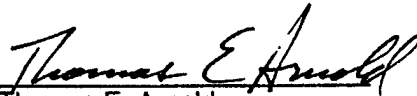
  
Thomas E. Arnold  
Manager, Engineering

  
Louis J. Fritz  
Senior Engineer

This report may only be duplicated or copied in its entirety

**Table I**

Low Cycle Fatigue Data

P.O. 63541

AI 2024-T3 Clad Face

Stress Ratio : R = 0.1  
 Temperature: 75°F

Frequency : 10 Hz  
 Waveform: Sinusoidal

Test Number	Specimen Number	Dimensions (in)		Stress (ksi)		Nf	Results	Test Hours	Test Machine
		Width	Thick.	Max.	Alt.				
8-03	AR 1	0.9997	0.0174	44.5	20.2	40,116	Frac/Radius	1.1	60017
13-03	AR 2	1.0020	0.0160	36.0	16.4	100,145	Removal	2.8	60017
11-03	AR 3	0.9997	0.0156	38.0	17.3	92,045	Frac/Radius	2.6	60017
17-03	AR 4	0.9900	0.0157	40.0	18.2	88,343	Frac/Radius	2.5	60017
47-03	AR 5	0.9997	0.0157	38.0	17.3	120,000	Removal	3.3	60073
48-03	AR 6	0.9900	0.0160	40.0	18.2	67,237	Frac/Radius	1.9	60073
49-03	AR 7	0.9991	0.0158	40.0	18.2	74,111	Frac/Radius	2.1	60073
50-03	AR 8	0.9991	0.0156	40.0	18.2	101,700	Frac/Radius	2.8	60073
51-03	AR 9	0.9984	0.0161	40.0	18.2	76,676	Frac/Radius	2.1	60073
52-03	AR 10	0.9989	0.0160	40.0	18.2	83,929	Frac/Radius	2.3	60073
9-03	AR 11	0.9980	0.0160	40.0	18.2	94,228	Frac/Radius	2.6	60017
53-03	AR 12	0.9970	0.0159	40.0	18.2	87,327	Frac/Radius	2.4	60073
54-03	AR 13	0.9961	0.0158	40.0	18.2	100,758	Frac/Radius	2.8	60073
55-03	AR 14	0.9949	0.0160	40.0	18.2	77,394	Frac/Radius	2.1	60073
56-03	AR 15	0.9929	0.0157	40.0	18.2	93,755	Frac/Radius	2.6	60073

**Table II**

Low Cycle Fatigue Data

P.O. 63541

Al 2024-T3 Clad Face

Stress Ratio : R = 0.1

Temperature: 75°F

Frequency : 10 Hz

Waveform: Sinusoidal

Test Number	Specimen Number	Dimensions (in)		Stress (ksi)		Nf	Results	Test Hours	Test Machine
		Width	Thick.	Max.	Alt.				
57-03	N 26	0.9995	0.0159	40.0	18.2	36,584	Frac/Gage	1.0	60073
58-03	N27	0.9998	0.0158	40.0	18.2	67,527	Frac/Radius	1.9	60073
59-03	N28	0.9999	0.0158	40.0	18.2	80,355	Frac/Gage	2.2	60073
60-03	N 29	1.0002	0.0159	40.0	18.2	77,450	Frac/Radius	2.2	60073
61-03	N 30	1.0002	0.0159	40.0	18.2	45	Frac/Radius	0.0	60073
62-03	N 31	1.0004	0.0156	40.0	18.2	27,665	Buckled	0.8	60073
63-03	N 32	1.0001	0.0161	40.0	18.2	49,075	Frac/Gage	1.4	60073
64-03	N 33	1.0005	0.0156	40.0	18.2	72,499	Frac/Gage	2.0	60073
65-03	N 34	1.0000	0.0155	40.0	18.2	91,650	Frac/Gage	2.5	60073
66-03	N 35	1.0000	0.0160	40.0	18.2	61,220	Frac/Radius	1.7	60073

Table III

## Low Cycle Fatigue Data

P.O. 63541

Al 2024-T3 Clad Face

Stress Ratio : R = 0.1

Frequency : 10 Hz

Temperature: 75°F

Waveform: Sinusoidal

Test Number	Specimen Number	Dimensions (in)		Stress (ksi)		Nf	Results	Test Hours	Test Machine
		Width	Thick.	Max.	Alt.				
67-03	0.5 N 16	0.9995	0.0158	40.0	18.2	82,998	Frac/Gage	2.3	60073
68-03	0.5 N 17	0.9995	0.0158	40.0	18.2	76,923	Frac/Radius	2.1	60073
69-03	0.5 N 18	0.9993	0.0159	40.0	18.2	84,479	Frac/Gage	2.3	60073
70-03	0.5 N 19	0.9989	0.0159	40.0	18.2	69,337	Frac/Radius	1.9	60073
71-03	0.5 N 20	0.9987	0.0158	40.0	18.2	94,511	Frac/Gage	2.6	60073
72-03	0.5 N 21	0.9987	0.0173	40.0	18.2	50,500	Frac/Radius	1.4	60073
73-03	0.5 N 22	0.9979	0.0159	40.0	18.2	71,024	Frac/Radius	2.0	60073
74-03	0.5 N 23	0.9972	0.0158	40.0	18.2	68,562	Frac/Gage	1.9	60073
75-03	0.5 N 24	0.9959	0.0156	40.0	18.2	88,300	Frac/Radius	2.5	60073
76-03	0.5 N 25	0.9941	0.0159	40.0	18.2	60,264	Frac/Radius	1.7	60073

**Table IV**

Low Cycle Fatigue Data

P.O. 63541

Al 2024-T3 Clad Spot Weld

Stress Ratio : R = 0.1

Temperature: 75°F

Frequency : 10 Hz

Waveform: Sinusoidal

Test Number	Specimen Number	Load (lb)		Nf	Results	Test Hours	Test Machine
		Max.	Alt.				
1-03	11-F-1	196.0	---		Fractured On Loading	0.1	60017
2-03	11-F-2	167.0	---		Fractured On Loading	0.1	60017
3-03	11-F-3	150.0	68.2	1,409	Frac/Spot Weld	0.1	60017
4-03	12-F-5	125.0	56.8	3,627	Frac/Spot Weld	0.1	60017
5-03	12-F-6	100.0	45.5	8,291	Frac/Spot Weld	0.2	60017
6-03	12-F-7	75.0	34.1	111,257	Frac/Spot Weld	3.1	60017
7-03	13-F-1	85.0	38.6	4,174	Frac/Spot Weld	0.1	60017
10-03	13-F-2	80.0	36.4	49,537	Frac/Spot Weld	1.4	60017
12-03	14-F-5	75.0	34.1	101,698	Removal	2.8	60017
14-03	14-F-6	78.0	35.5	111,495	Removal	3.1	60017
15-03	11-F-4	80.0	36.4	143,702	Frac/Spot Weld	4.0	60017

**Table V**

Low Cycle Fatigue Data

P.O. 63541

AI 2024-T3 Clad Spot Weld

Stress Ratio : R = 0.1

Frequency : 10 Hz

Temperature: 75°F

Waveform: Sinusoidal

Test Number	Specimen Number	Load (lb)		Nf	Results	Test Hours	Test Machine
		Max.	Alt.				
16-03	11-F-6	80.0	36.4	98,861	Frac/ Spot Weld	2.7	60073
18-03	11-F-7	80.0	36.4	99,031	Frac/ Spot Weld	2.8	60073
19-03	12-F-1	80.0	36.4	9,623	Frac/ Spot Weld	0.3	60073
20-03	12-F-2	80.0	36.4	58,346	Frac/ Spot Weld	1.6	60073
21-03	13-F-4	80.0	36.4	60,490	Frac/ Spot Weld	1.7	60073
22-03	13-F-5	80.0	36.4	78,478	Frac/ Spot Weld	2.2	60073
23-03	13-F-6	80.0	36.4	111,495	Frac/ Spot Weld	3.1	60073
24-03	14-F-1	80.0	36.4	36,429	Frac/ Spot Weld	1.0	60073
25-03	14-F-2	80.0	36.4	45,148	Frac/ Spot Weld	1.3	60073
26-03	14-F-3	80.0	36.4	45,122	Frac/ Spot Weld	1.3	60073

**Table VI**

Low Cycle Fatigue Data

P.O. 63541

Al 2024-T3 Clad Spot Weld

Stress Ratio : R = 0.1

Frequency : 10 Hz

Temperature: 75°F

Waveform: Sinusoidal

Test Number	Specimen Number	Load (lb)		Nf	Results	Test Hours	Test Machine
		Max.	Alt.				
27-03	3-F-1	80.0	36.4	21,655	Frac/Spot Weld	0.6	60073
28-03	3-F-2	80.0	36.4	100,031	Frac/Spot Weld	2.8	60073
29-03	3-F-3	80.0	36.4	50,763	Frac/Spot Weld	1.4	60073
30-03	3-F-4	80.0	36.4	106,229	Frac/Spot Weld	3.0	60073
31-03	3-F-5	80.0	36.4	63,144	Frac/Spot Weld	1.8	60073
32-03	4-F-1	80.0	36.4	68,959	Frac/Spot Weld	1.9	60073
33-03	4-F-2	80.0	36.4	107,358	Removal	3.0	60073
34-03	4-F-3	80.0	36.4	83,304	Frac/Spot Weld	2.3	60073
35-03	4-F-4	80.0	36.4	159,878	Frac/Spot Weld	4.4	60073
36-03	4-F-5	80.0	36.4	100,860	Removal	2.8	60073

**Table VII**

Low Cycle Fatigue Data

P.O. 63541

AI 2024-T3 Clad Spot Weld

Stress Ratio : R = 0.1

Frequency : 10 Hz

Temperature: 75°F

Waveform: Sinusoidal

Test Number	Specimen Number	Load (lb)		Nf	Results	Test Hours	Test Machine
		Max.	Alt.				
37-03	8-F-1	80.0	36.4	100,016	Removal	2.8	60073
38-03	8-F-2	80.0	36.4	131,314	Frac/Spot Weld	3.6	60073
39-03	8-F-3	80.0	36.4	66,498	Frac/Spot Weld	1.8	60073
40-03	8-F-4	80.0	36.4	100,009	Removal	2.8	60073
41-03	8-F-5	80.0	36.4	86,851	Frac/Spot Weld	2.4	60073
42-03	8-F-6	80.0	36.4	159,818	Frac/Spot Weld	4.4	60073
43-03	8-F-7	80.0	36.4	142,833	Frac/Spot Weld	4.0	60073
44-03	8-F-8	80.0	36.4	100,594	Removal	2.8	60073
45-03	8-F-9	80.0	36.4	103,717	Frac/Spot Weld	2.9	60073
46-03	8-F-10	80.0	36.4	123,240	Frac/Spot Weld	3.4	60073

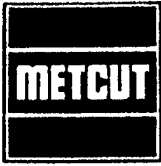

# LABORATORY REPORT

**To:** Southwest Research Institute  
Attn: Vince Krausey  
Post Office Drawer 28510  
San Antonio, TX 78284

**Project No.:** 635-69997-1  
**Date:** October 30, 1998  
**Authorization:** 63541

**Project:** Shear Testing of (25) Spot Welded Sheet Specimens Prepared by Metcut Research Inc. from Material Supplied and Identified by Southwest Research Institute.

Head Rate to Failure: 0.1 in./min.

Drawing No.: CT10 Sketch

See following page for test results.

  
Michael J. Booker, Supervisor

Creep, Stress Rupture & Tensile Testing

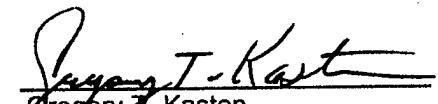
  
Gregory J. Kasten  
Engineering Assistant II

This report may only be duplicated or copied in its entirety.

**SHEAR TESTING RESULTS**

Metcut Test No.	Specimen Identification	Max Load (lbs)	Process Condition	SOD
T-121143	11-S-5	233	As Received	
T-121144	11-S-10	227	As Received	
T-121145	12-S-4	208	As Received	
T-121146	12-S-9	232	As Received	
T-121147	13-S-3	239	As Received	
T-121148	5-S-1	240	Zero Dwell	Normal
T-121149	5-S-2	239	Zero Dwell	Normal
T-121150	5-S-3	244	Zero Dwell	Normal
T-121151	5-S-4	235	Zero Dwell	Normal
T-121152	5-S-5	248	Zero Dwell	Normal
T-121153	6-S-1	226	Zero Dwell	0.5 Normal
T-121154	6-S-2	249	Zero Dwell	0.5 Normal
T-121155	6-S-3	243	Zero Dwell	0.5 Normal
T-121156	6-S-4	246	Zero Dwell	0.5 Normal
T-121157	6-S-5	253	Zero Dwell	0.5 Normal
T-121158	1-S-1	229	Zero Dwell	0.33 Normal
T-121159	1-S-2	242	Zero Dwell	0.33 Normal
T-121160	1-S-3	249	Zero Dwell	0.33 Normal
T-121161	9-S-6	233	Zero Dwell	0.33 Normal
T-121162	9-S-7	249	Zero Dwell	0.33 Normal
T-121163	2-S-1	254	2 Dwell	Normal
T-121164	2-S-2	252	2 Dwell	Normal
T-121165	2-S-3	240	2 Dwell	Normal
T-121166	9-S-4	228	2 Dwell	Normal
T-121167	9-S-5	233	2 Dwell	Normal

T-121143

AS-RECD

SPEC # ~~01~~ 11-5-5

RT

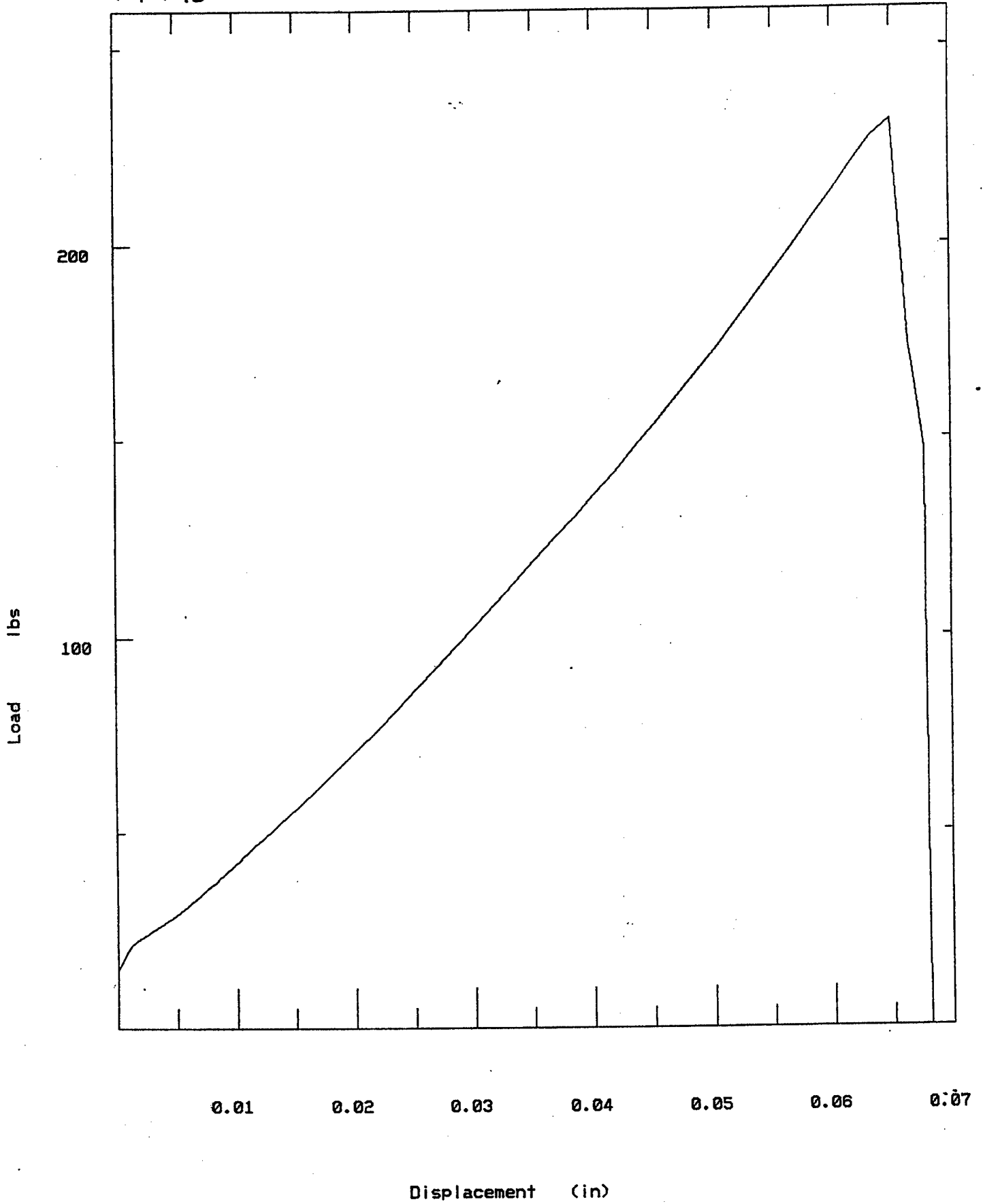

T-121144

AS-RECD

SPEC # 02-11-S-10

14

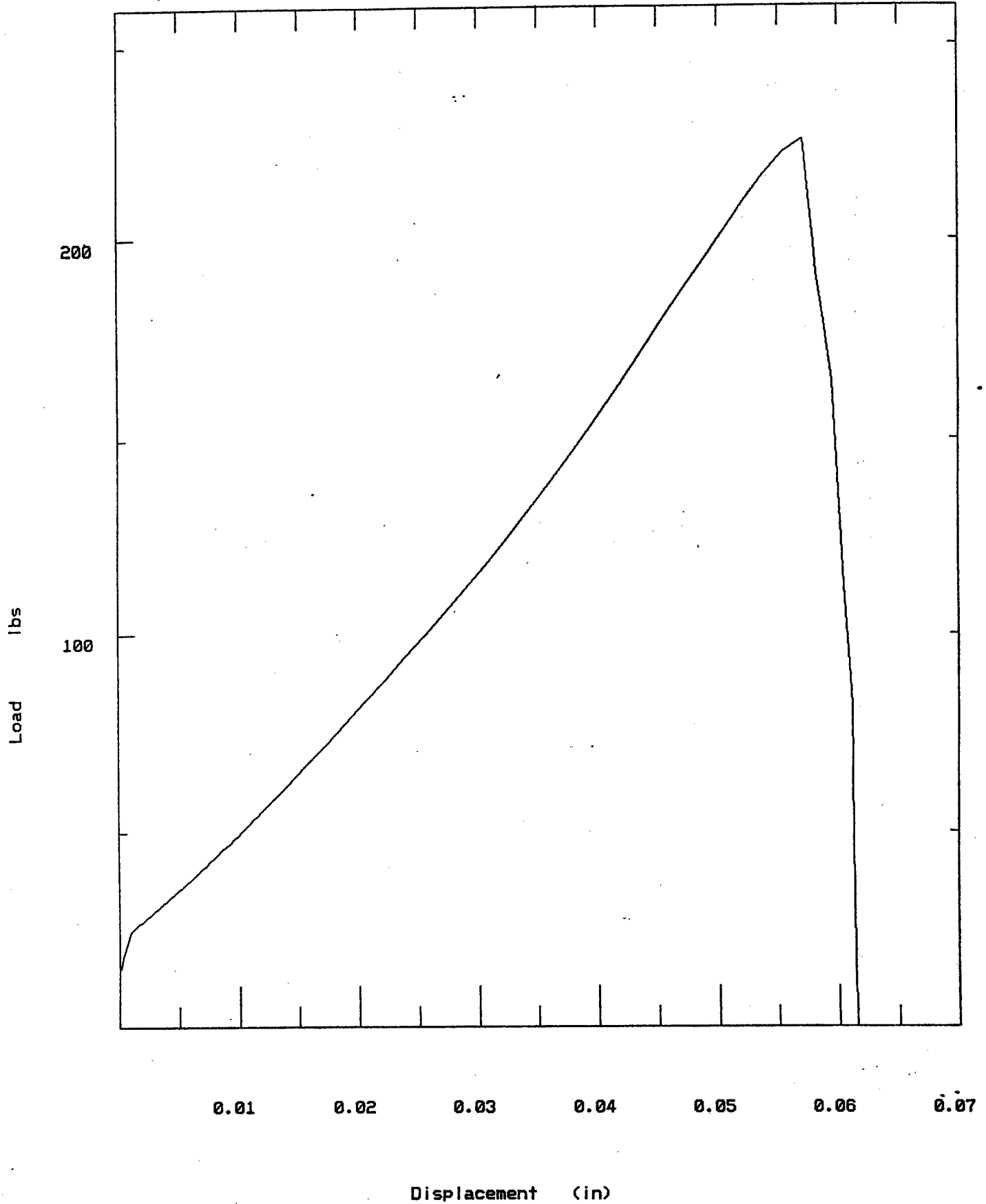

T-121145

AS-RECD

SPEC # 03 12-5-4

RT

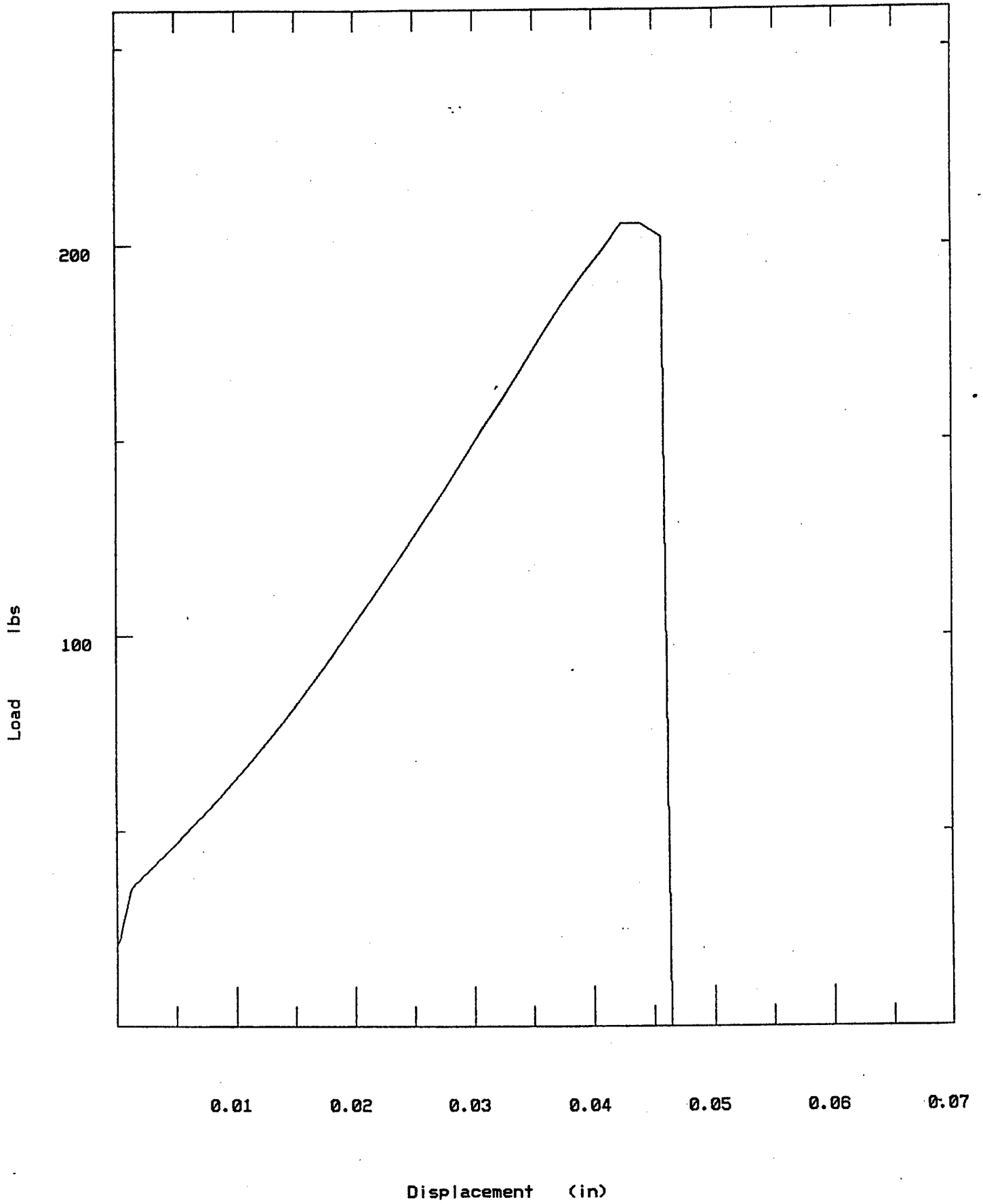

T-121146

AS-RECD

SPEC # 84 12-S-9

RT

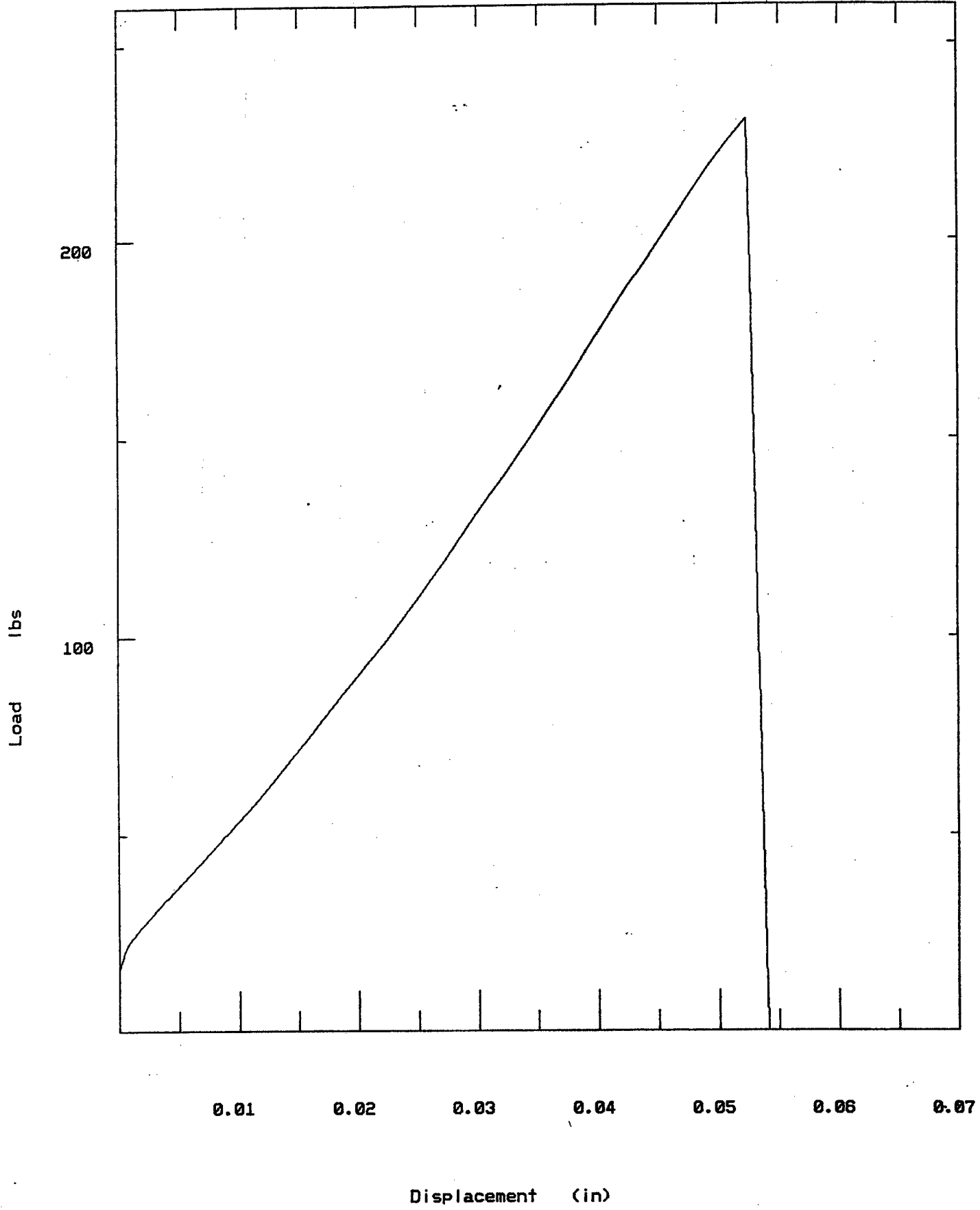

T-121147

AS-RECD

SPEC # 05 13-5-3

RT

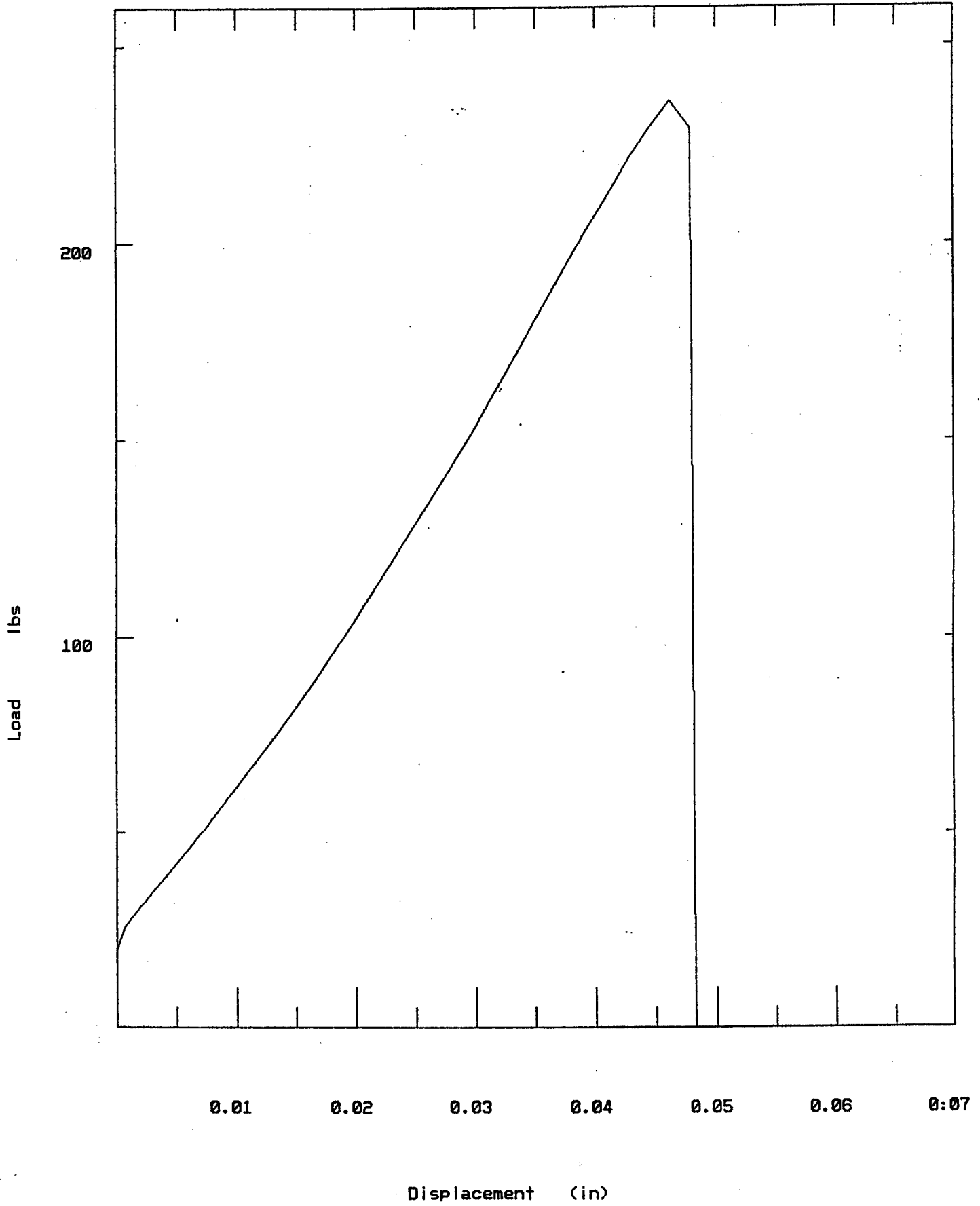

T-121148

5-S

SPEC # 01

RT

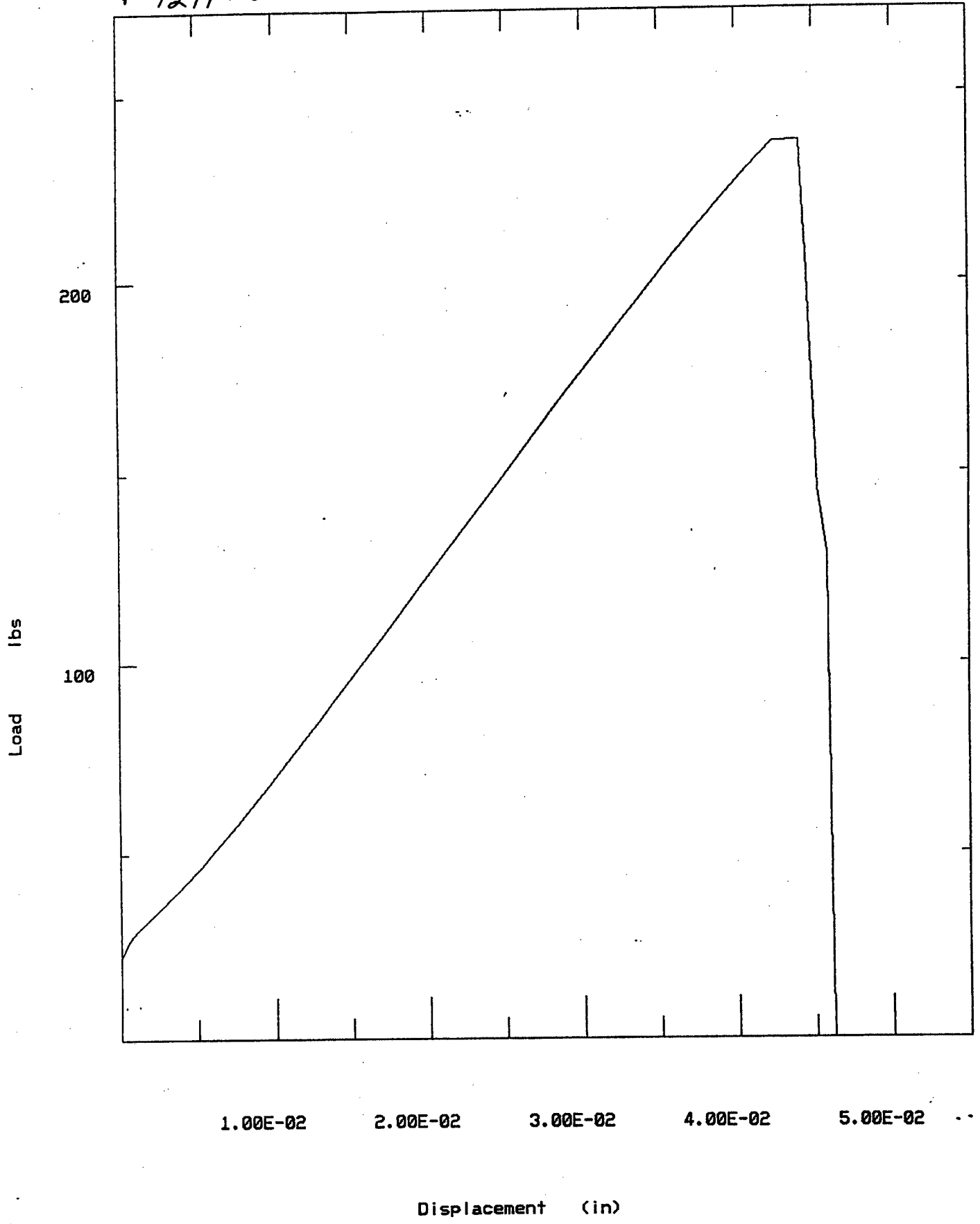

T-121149

5-S

SPEC # 02

RT

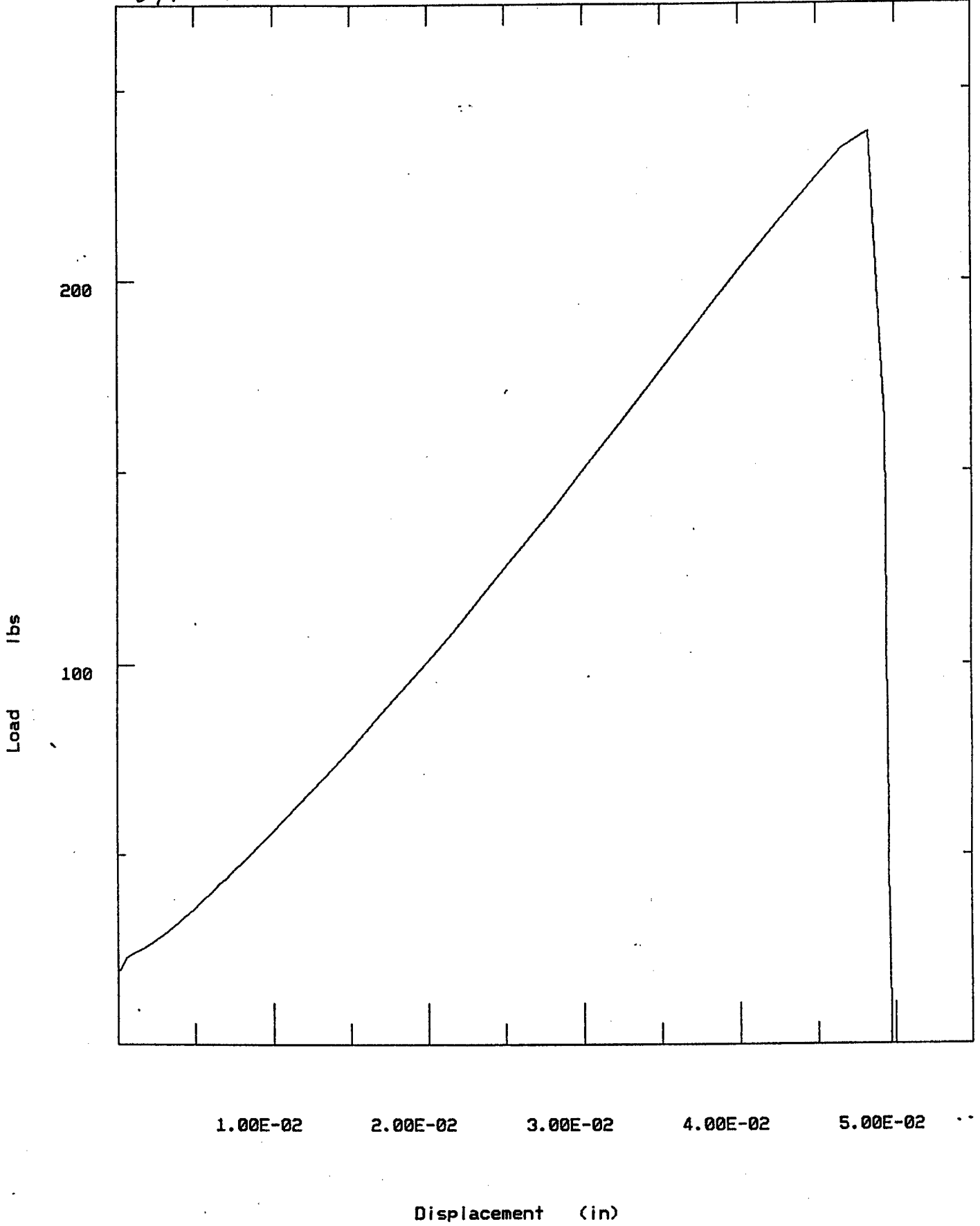

T-121150

5-S

SPEC # 03

RT

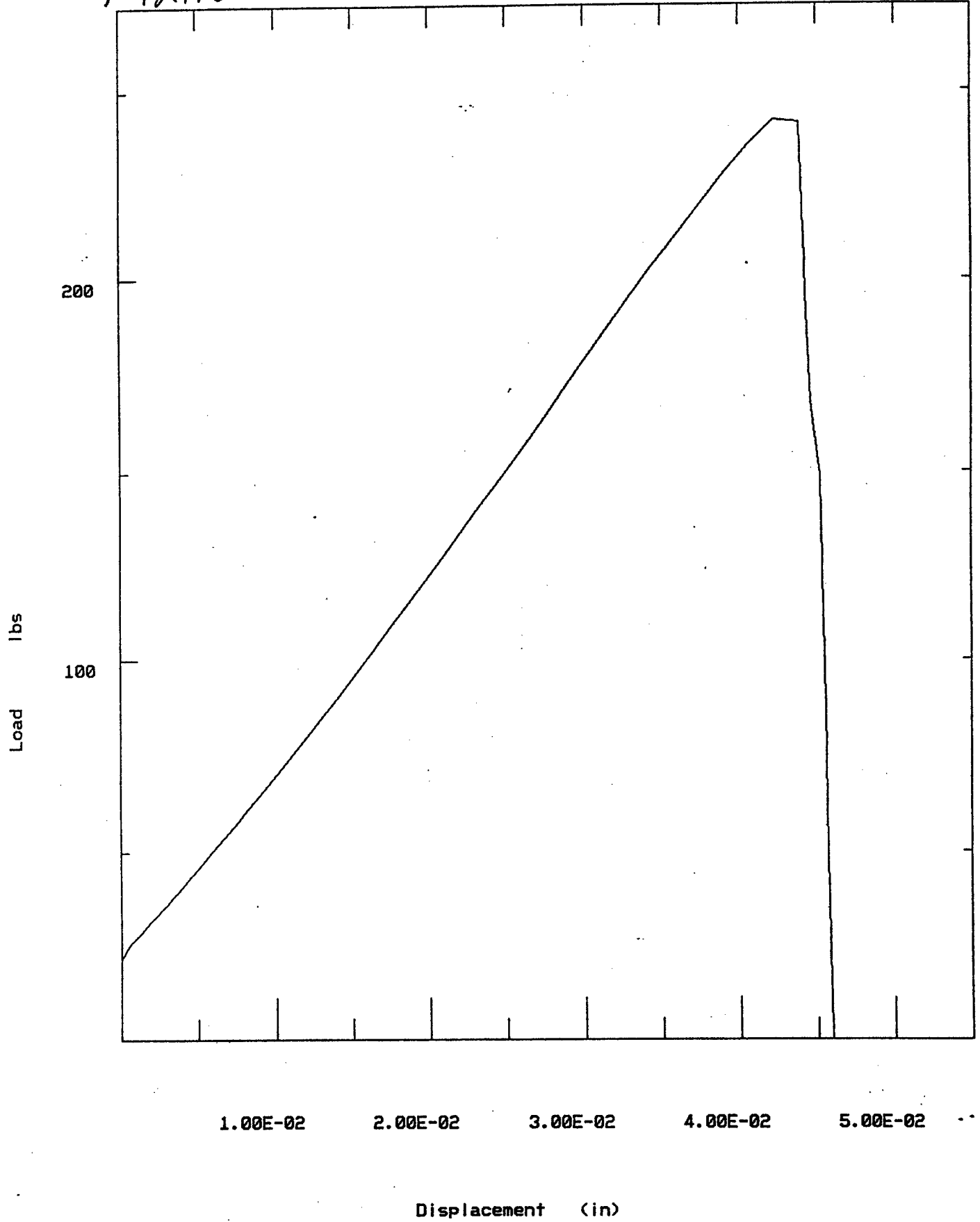

T-121151

5-S

SPEC # 04

RT

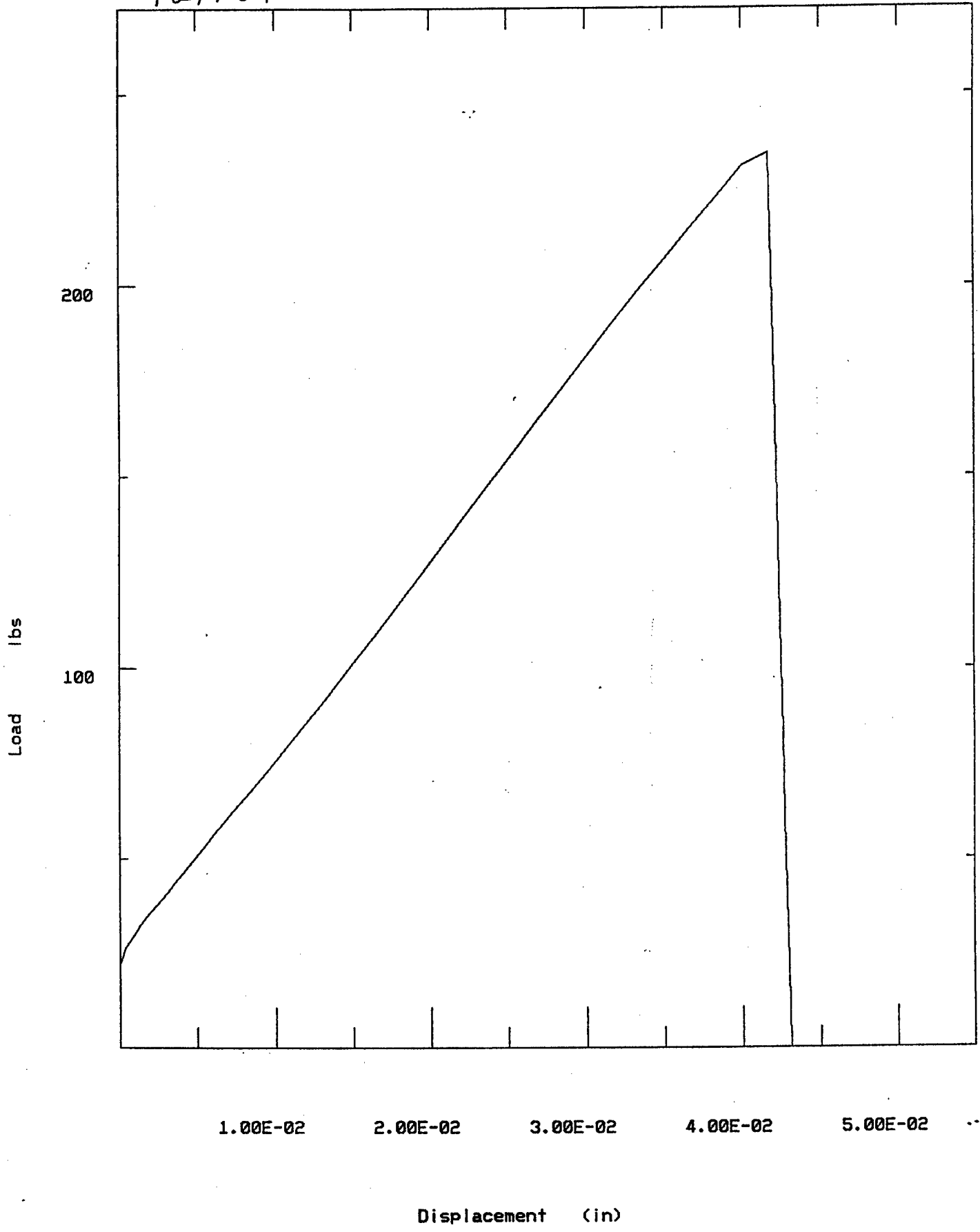

T-121152

5-S

SPEC # 05

RT

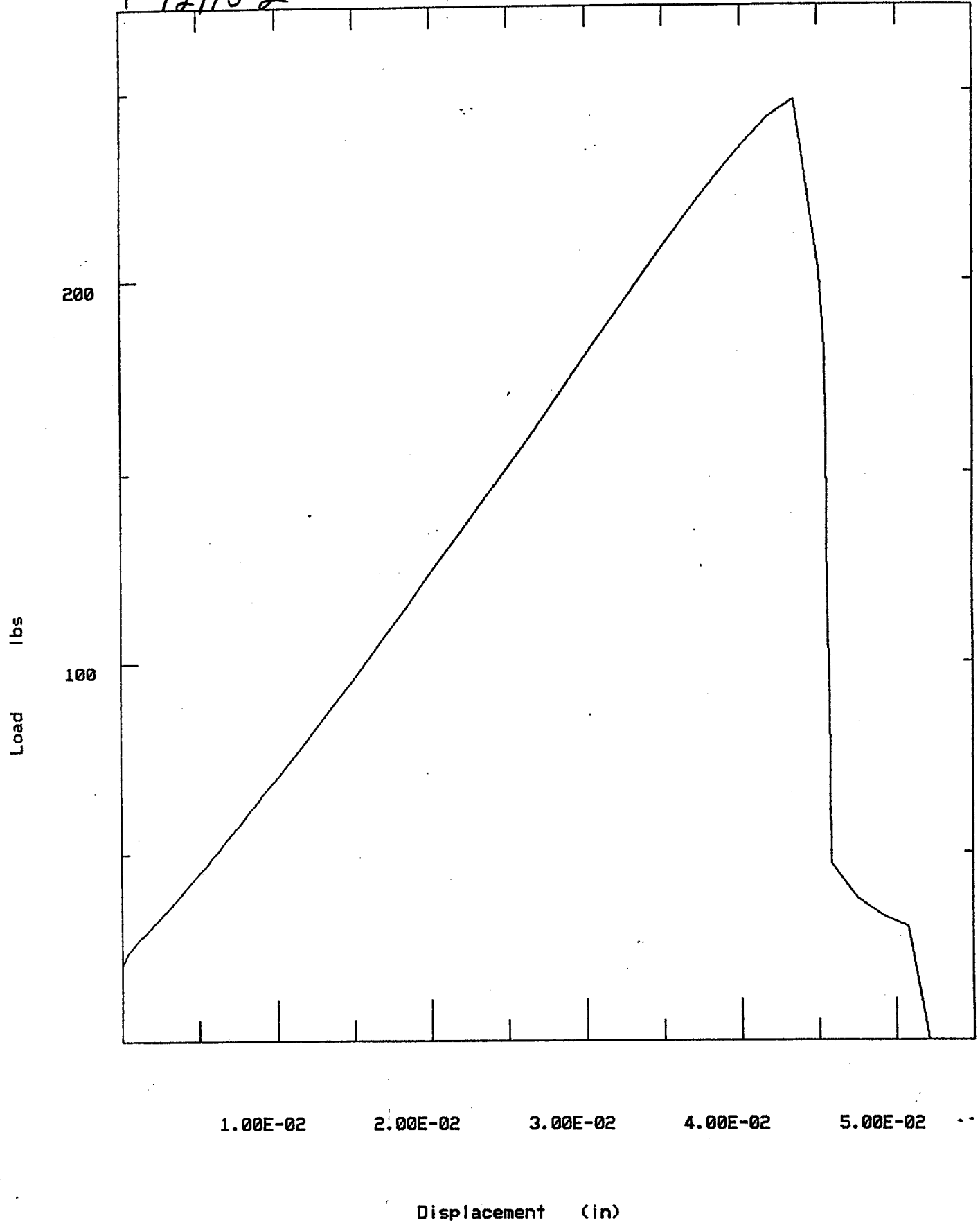

T-121153

6-S

SPEC # 01

RT

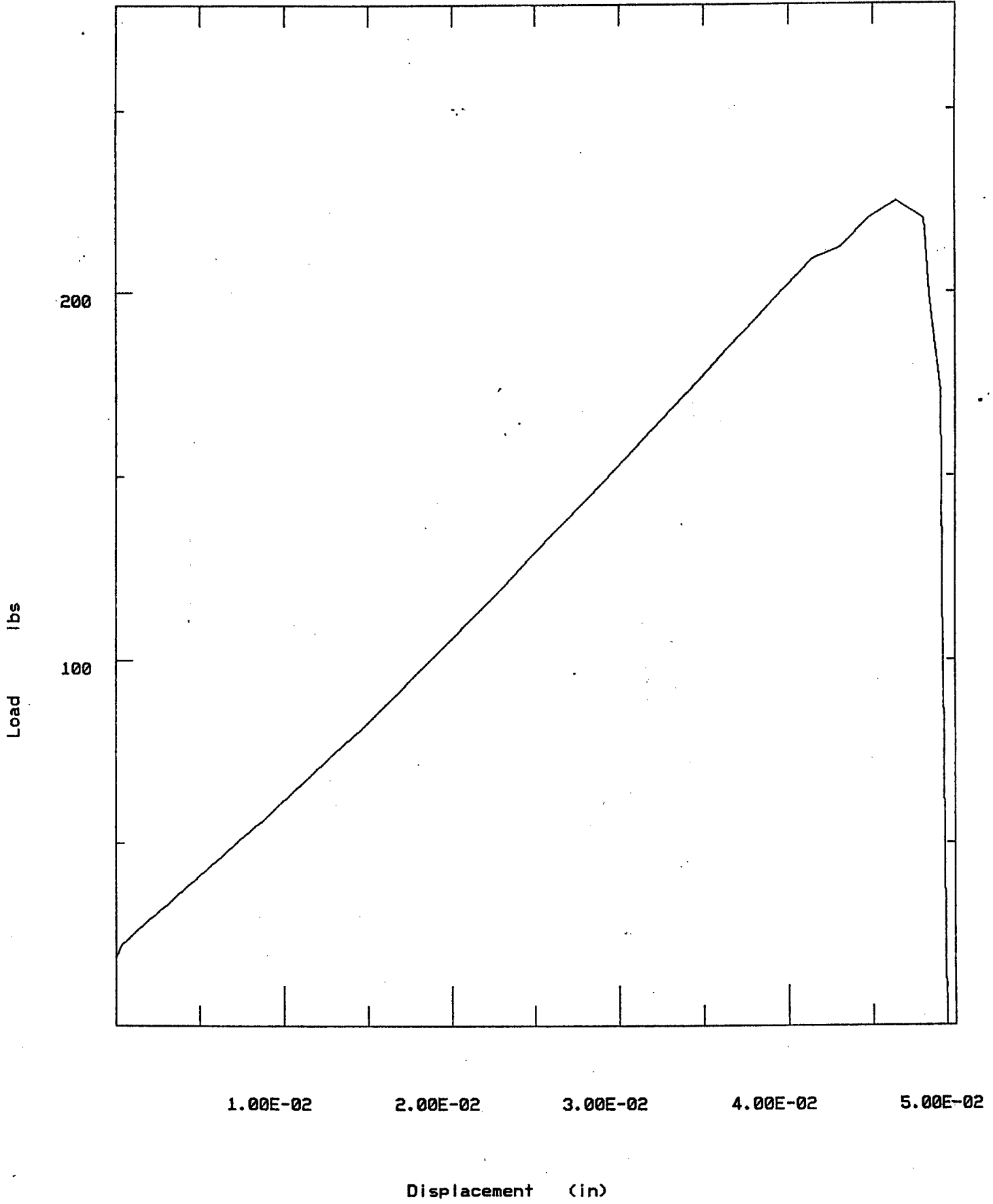

T-121154

6-S

SPEC # 02

RT

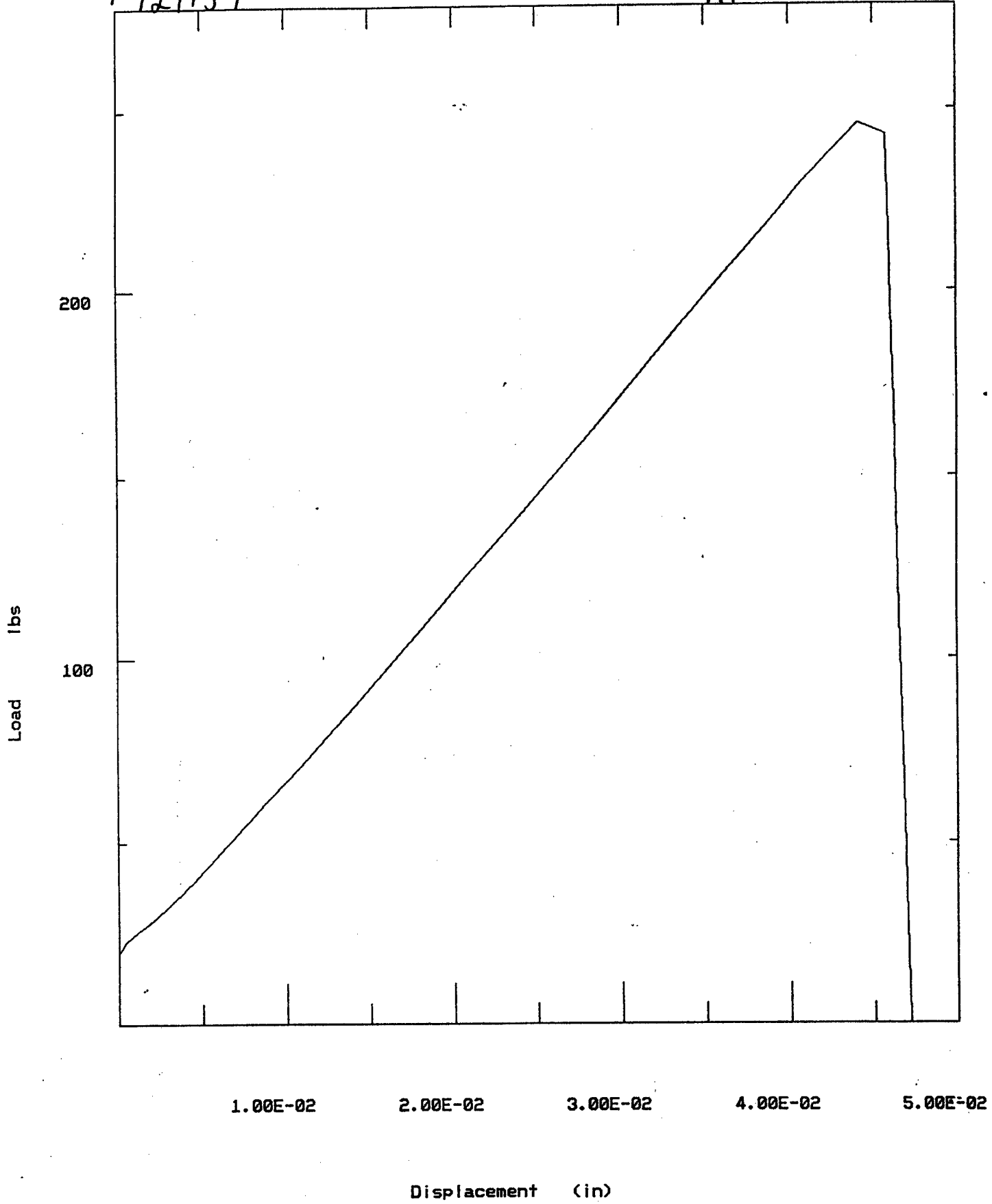

F-121155

6-S

SPEC # 03

RT

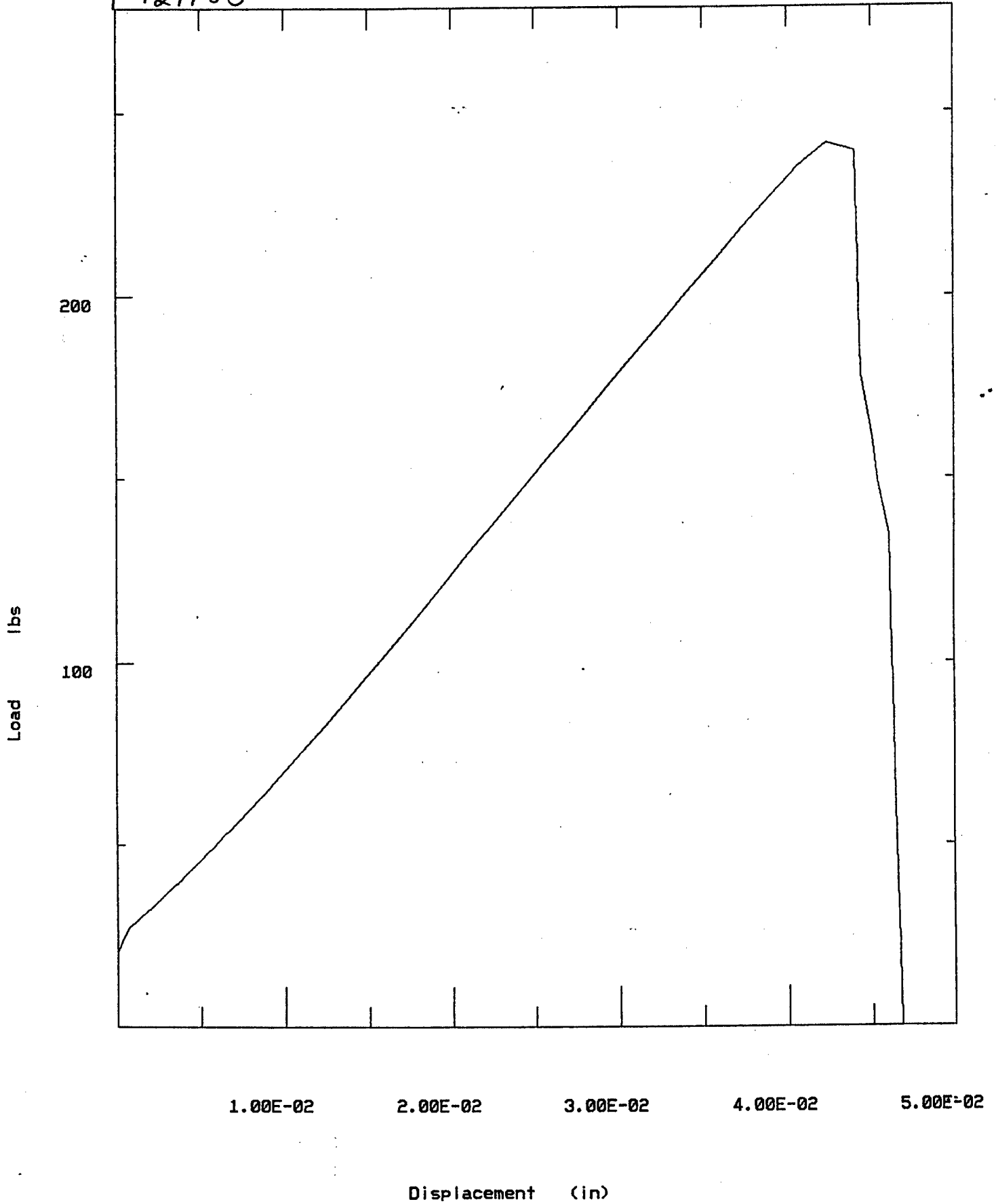

T-121156

6-S

SPEC # 04

RT

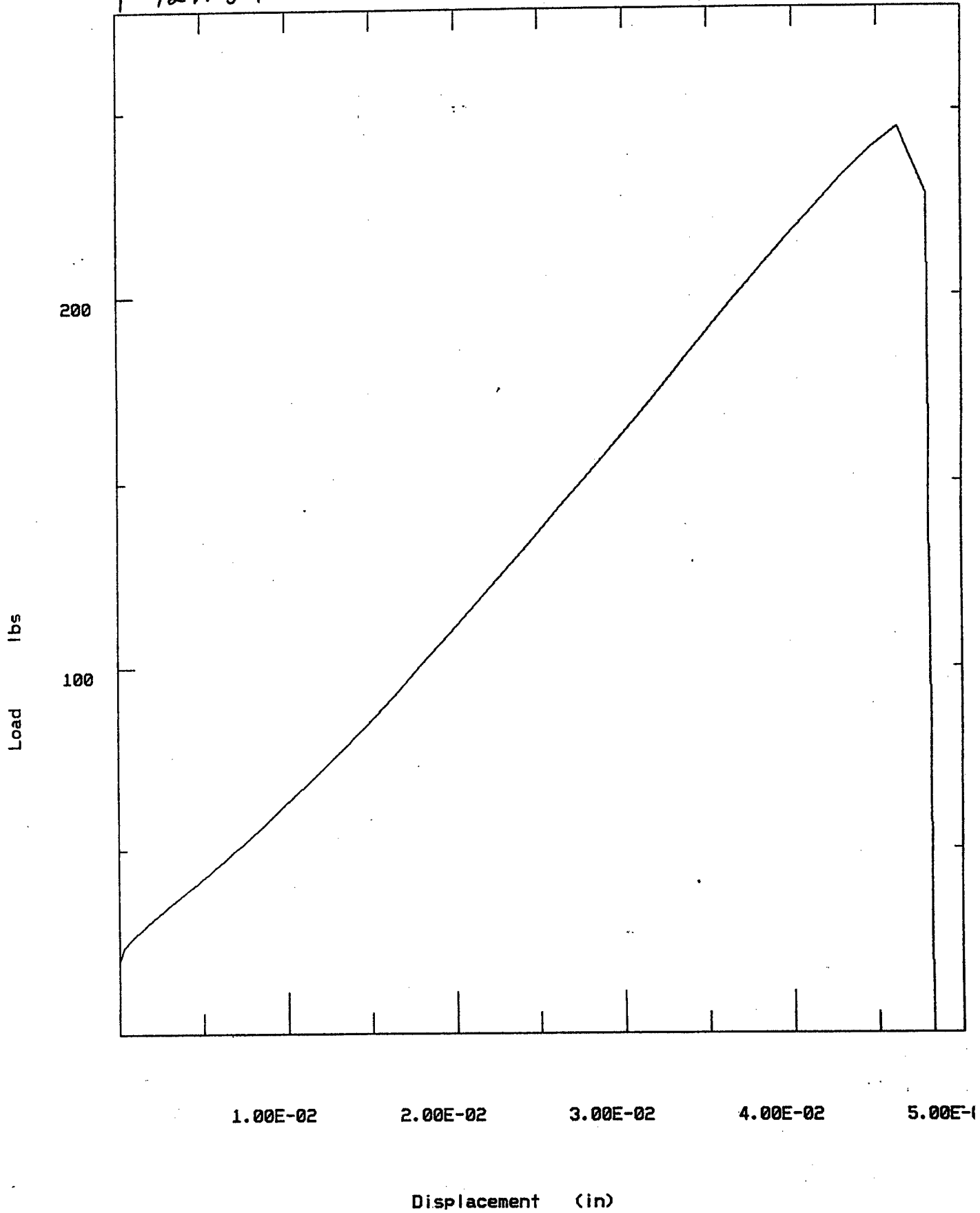

T-121157

6-S

SPEC # 05

RT

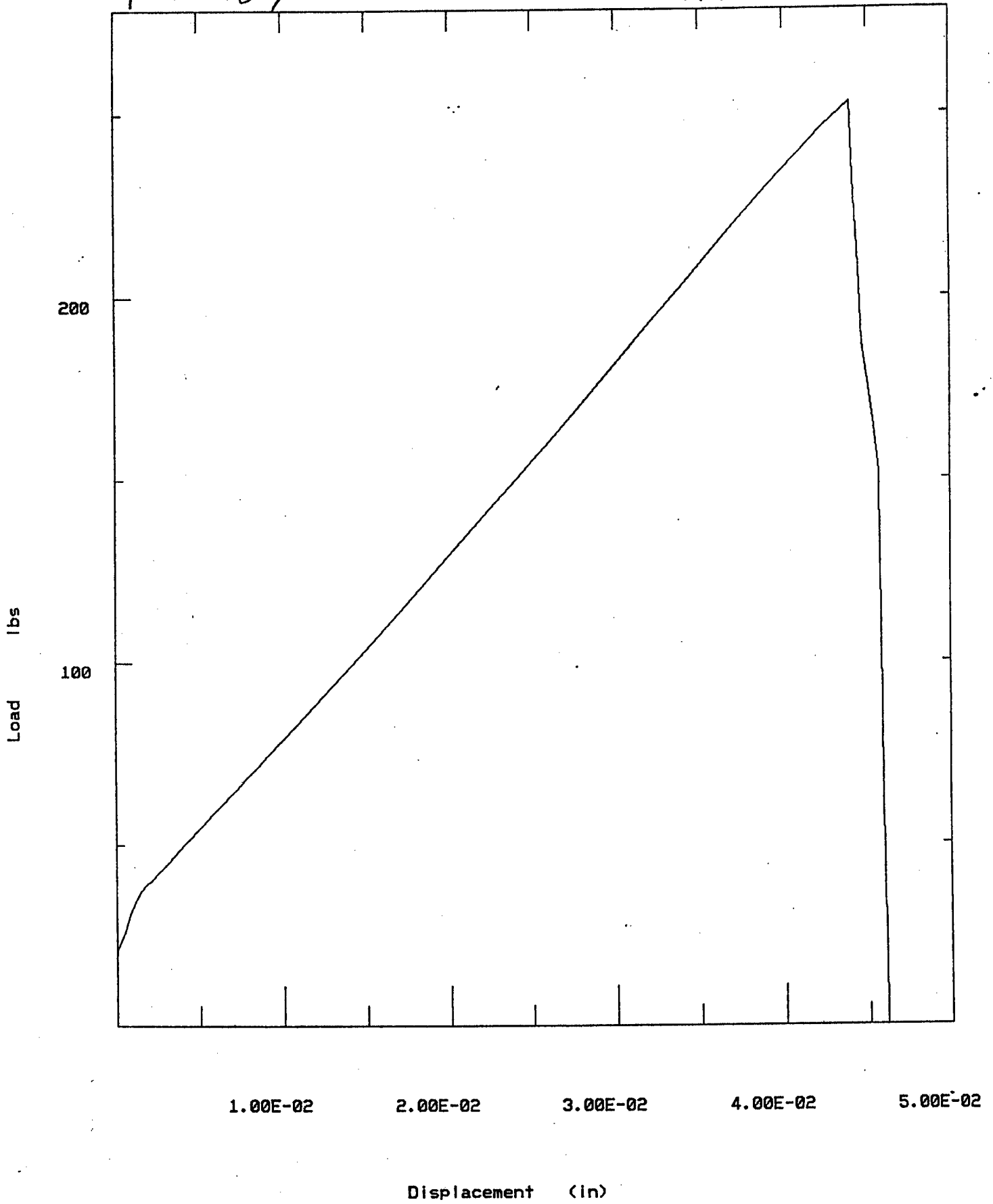

F-121158

69997-1

SPEC #01 1-5-1

RT

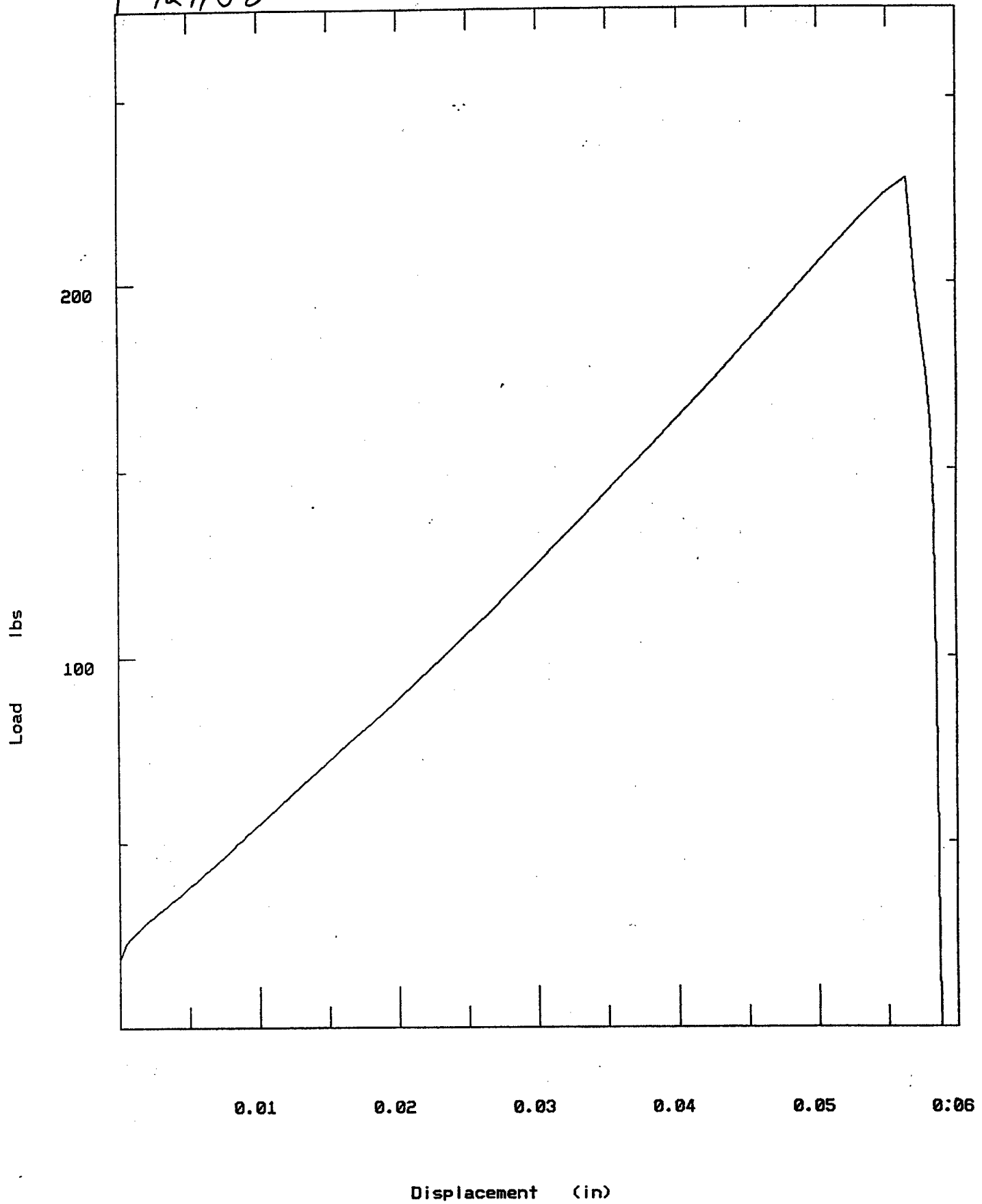

T-121159

69997-1

SPEC # 02

1-5-2

RT

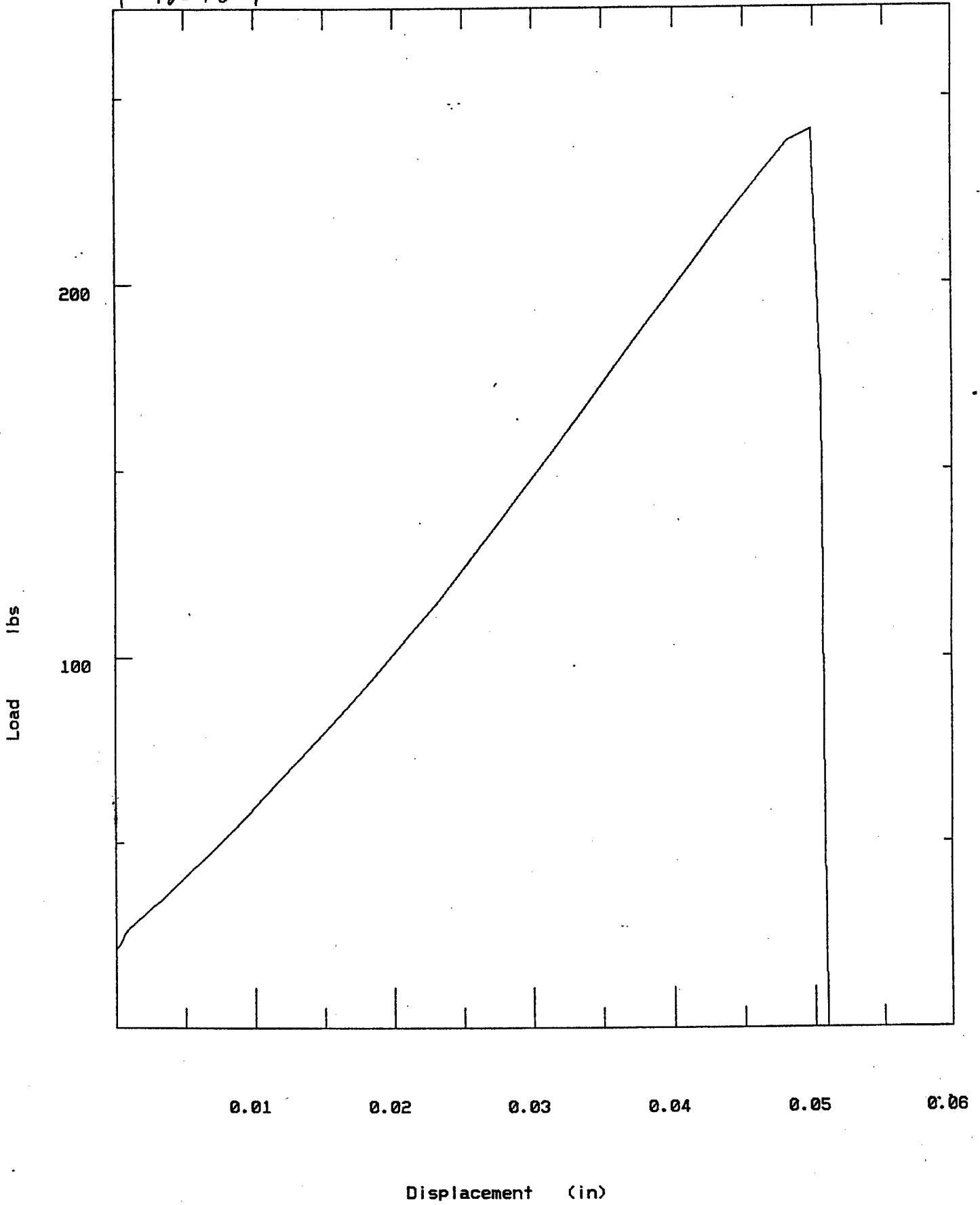

T-121160

69997-1

SPEC # ~~02~~

1-5-3

RT

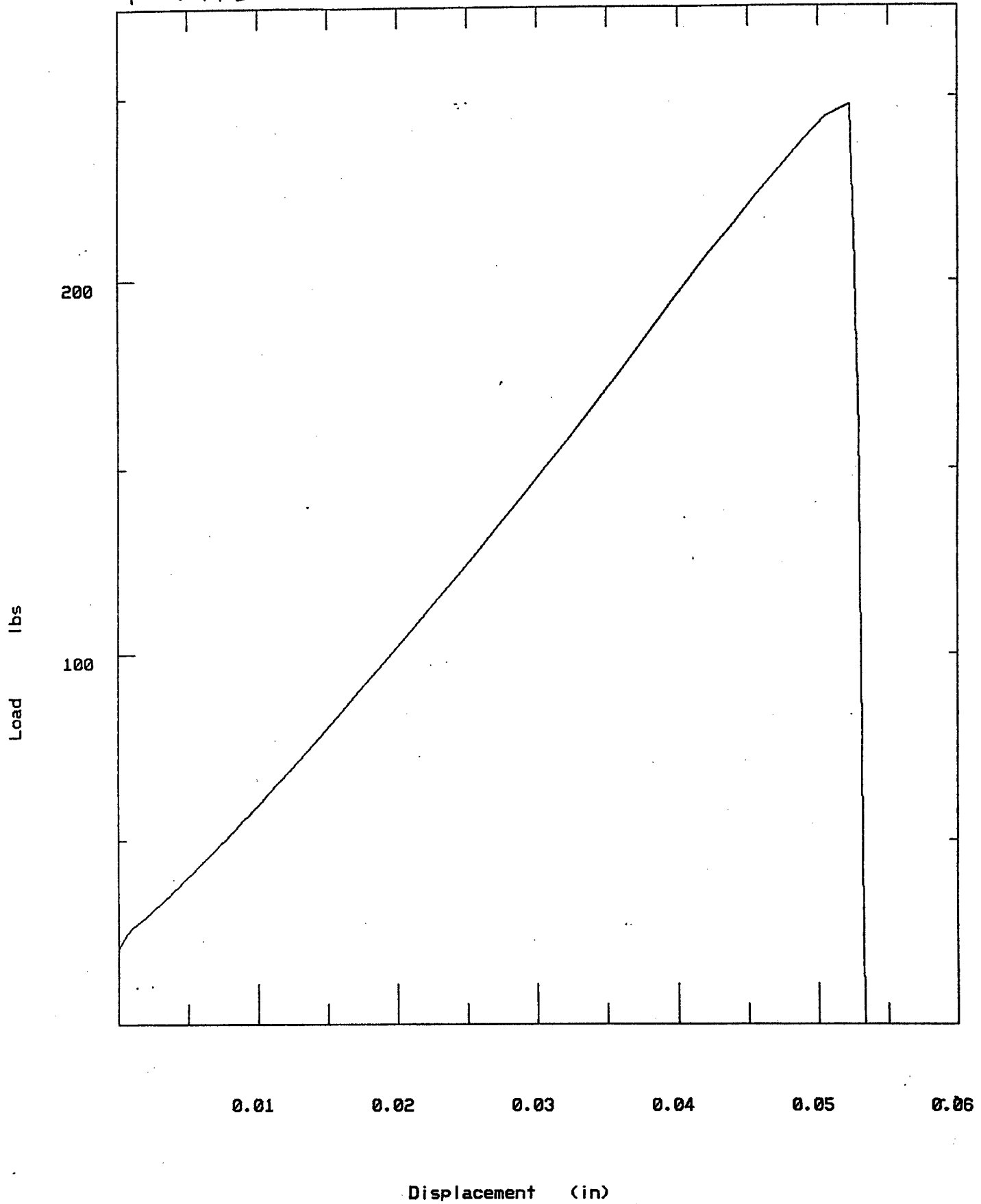

T-121161

69997-1

SPEC # 04

3-5-6

RT

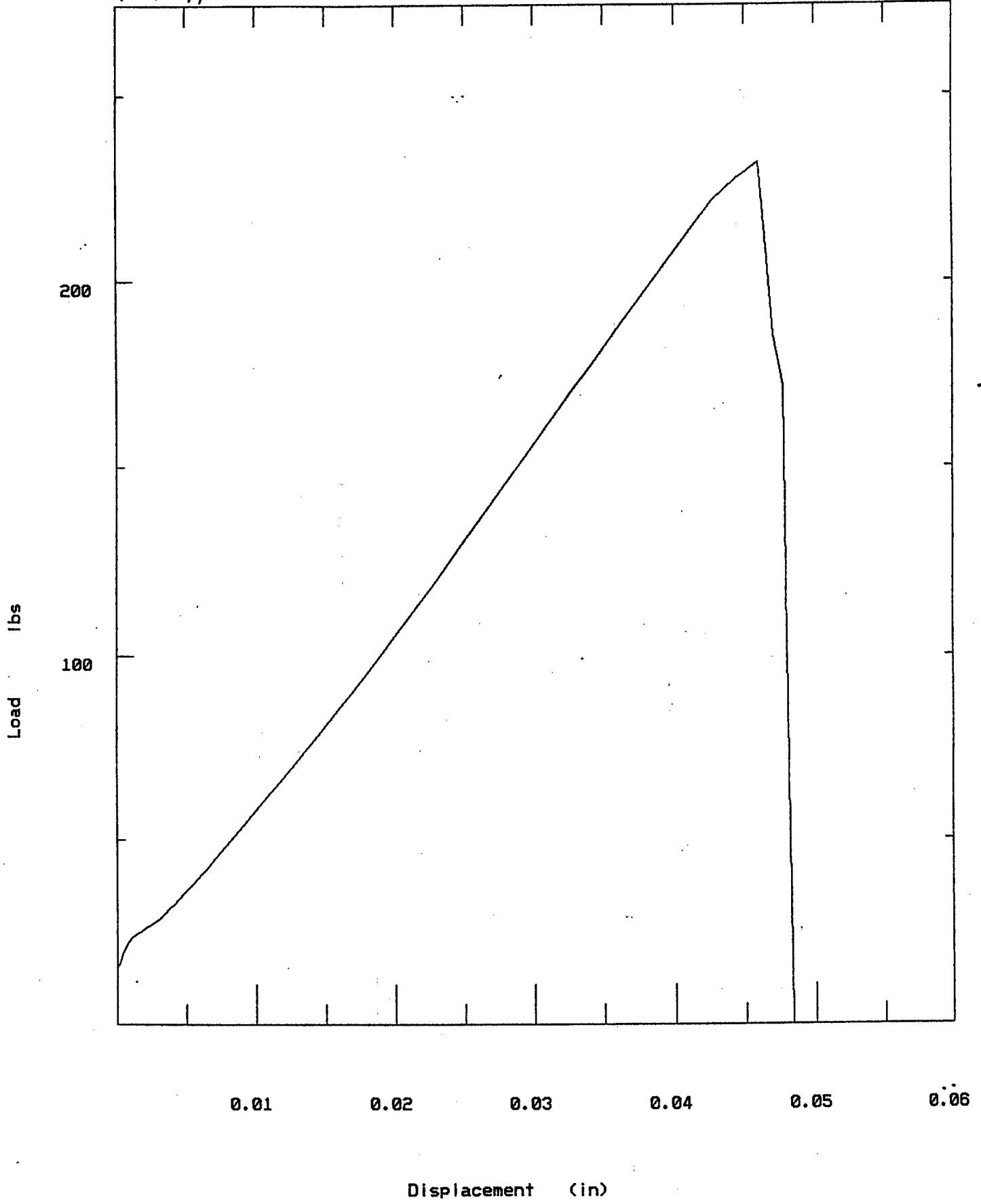

T-121162

69997-1

SPEC # ~~85~~ 957- RT

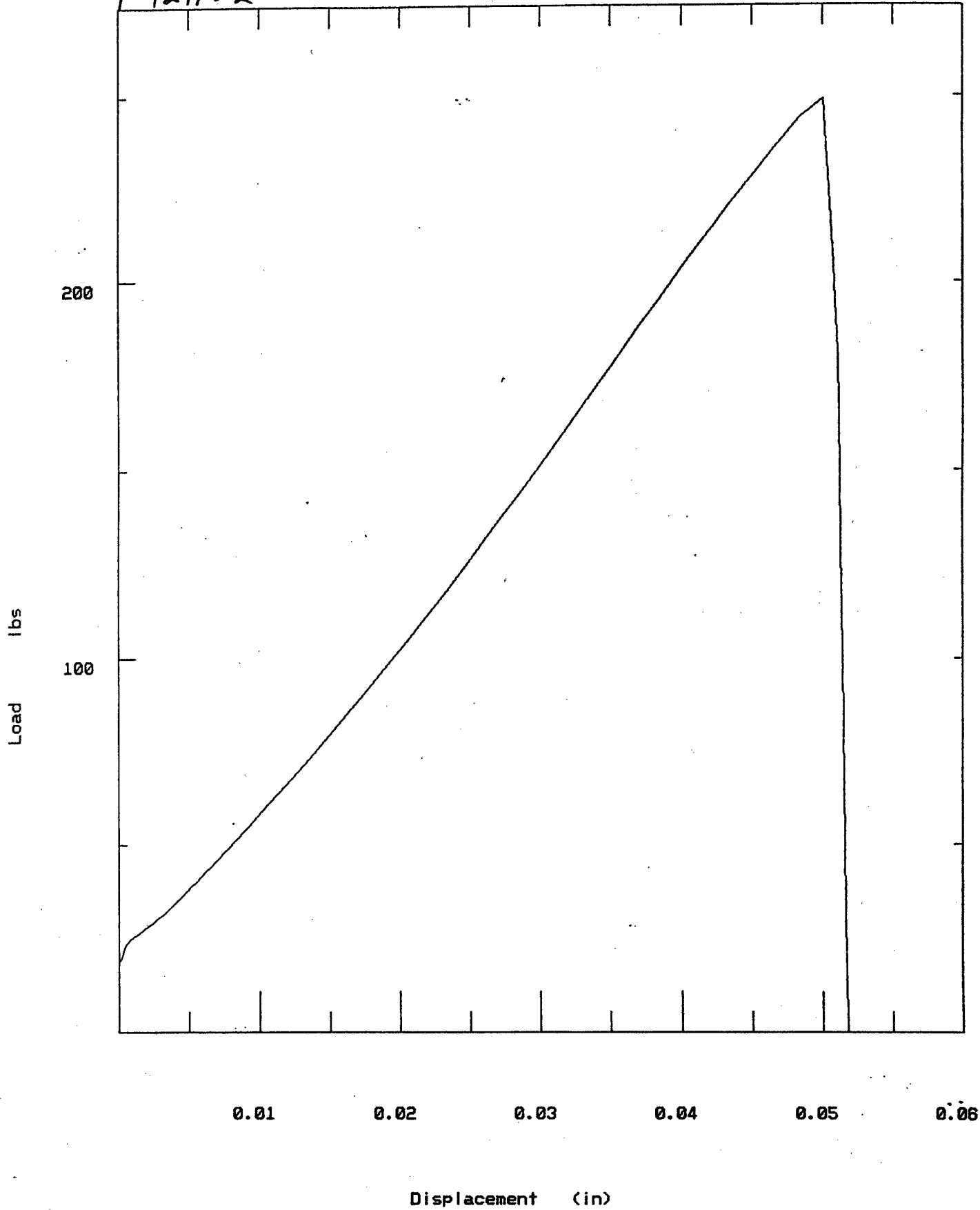

T-12/163

69997

SPEC #01

2-5-1

RT

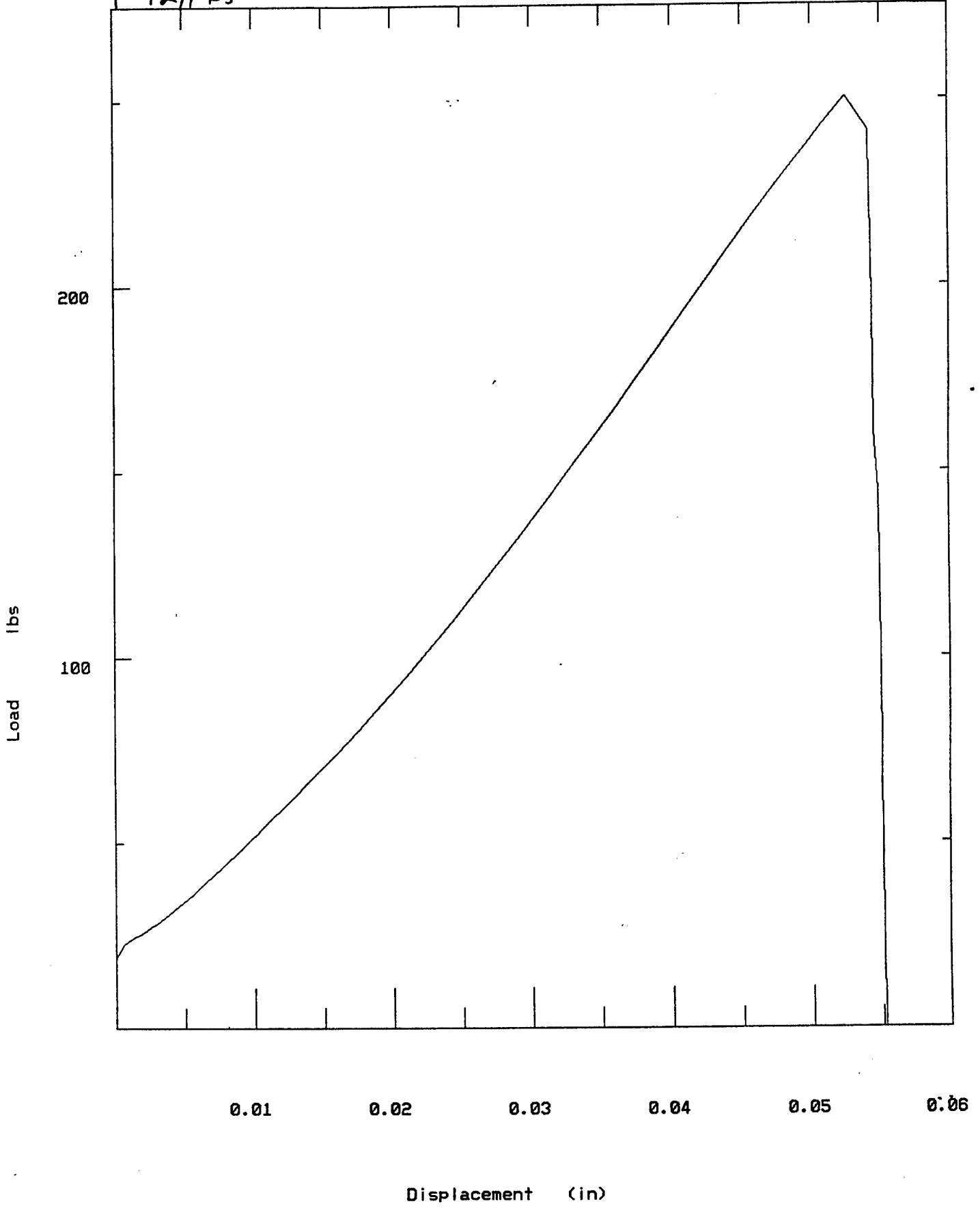

T-121164

69997

SPEC #02

2-5-2

RT

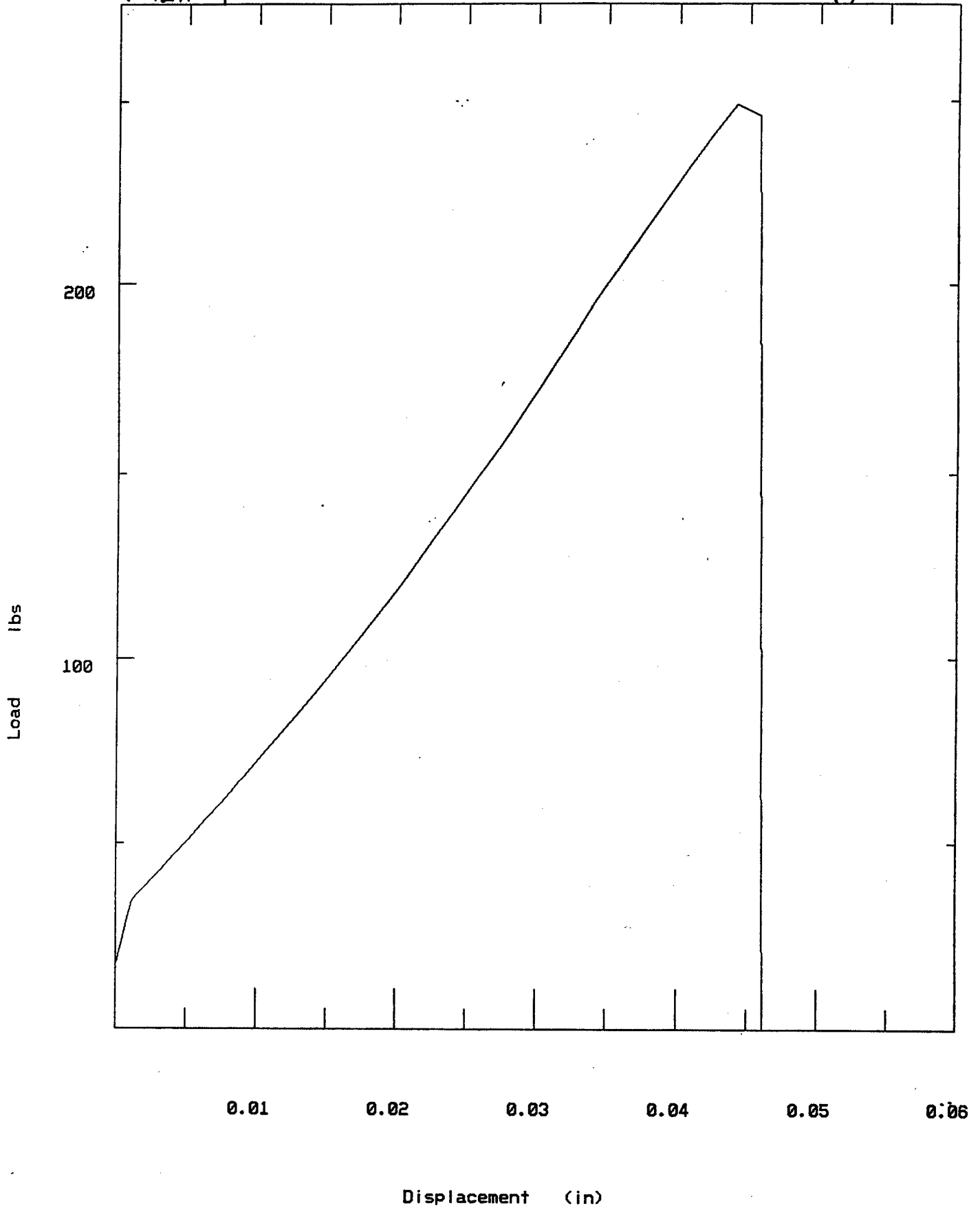

T-121165

69997

SPEC # ~~03~~ 2-5-3

BT

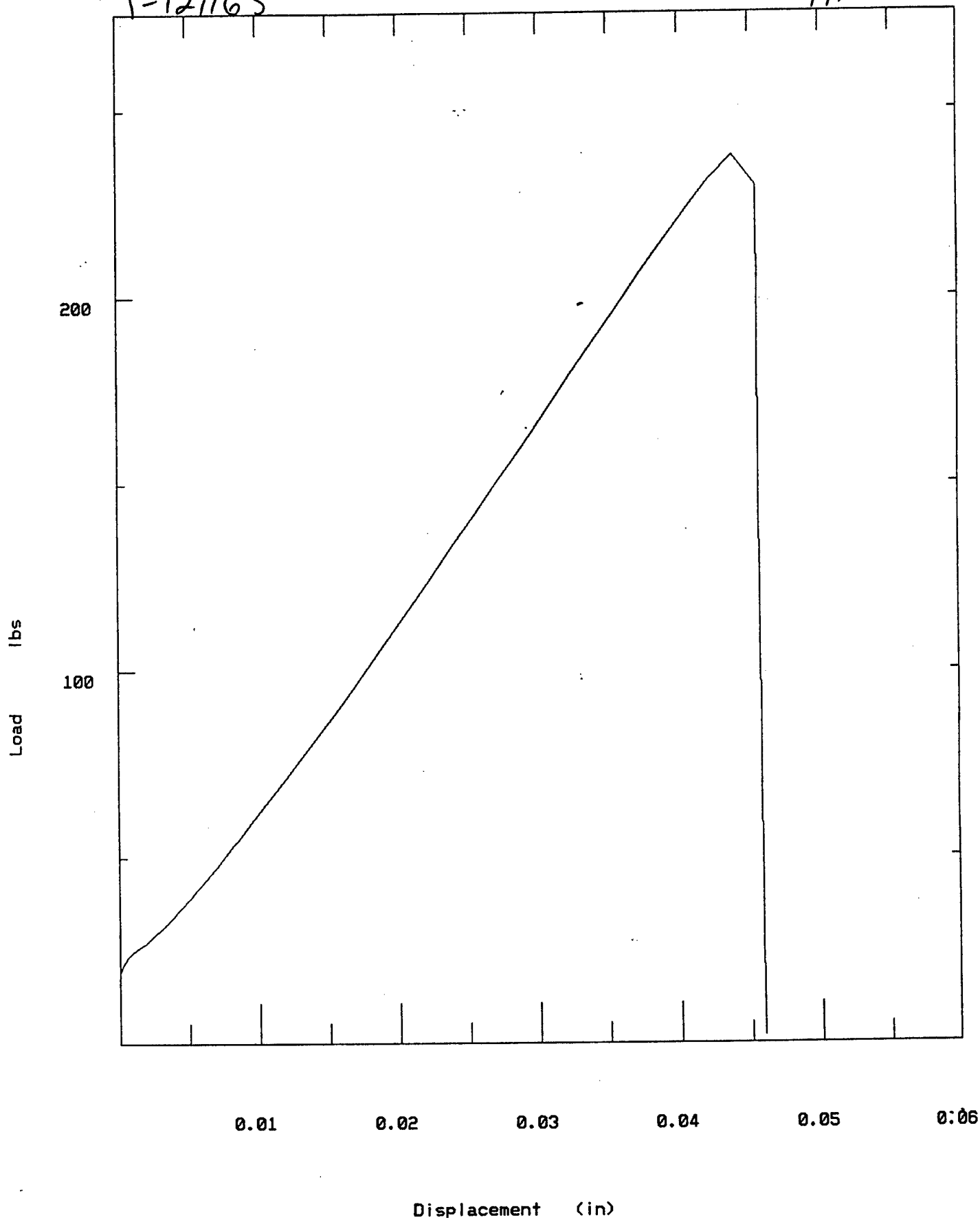

T-121766

69997

SPEC #04

A-5-4

RT

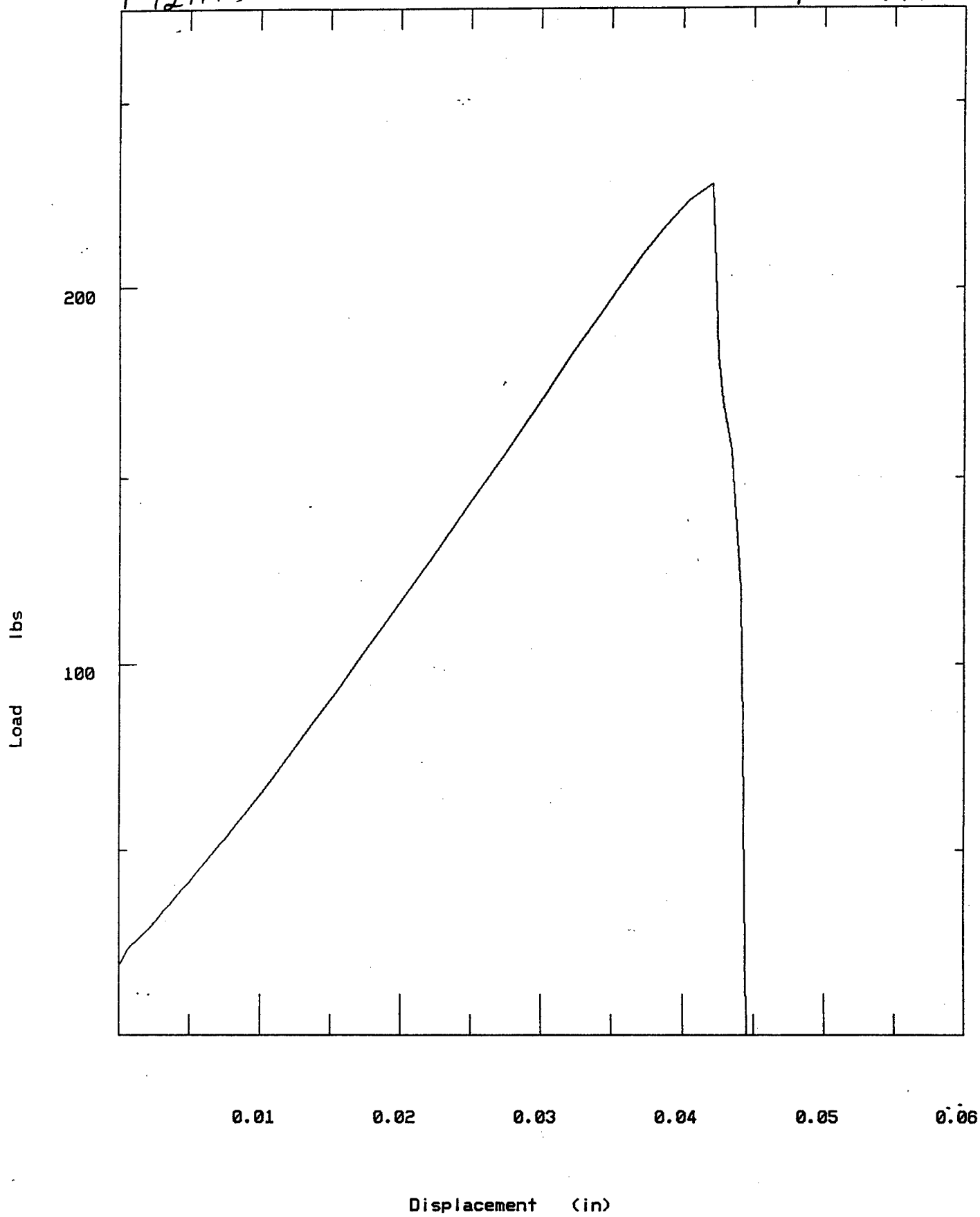

T-121167

69997

SPEC # 05 9-5-5

RT

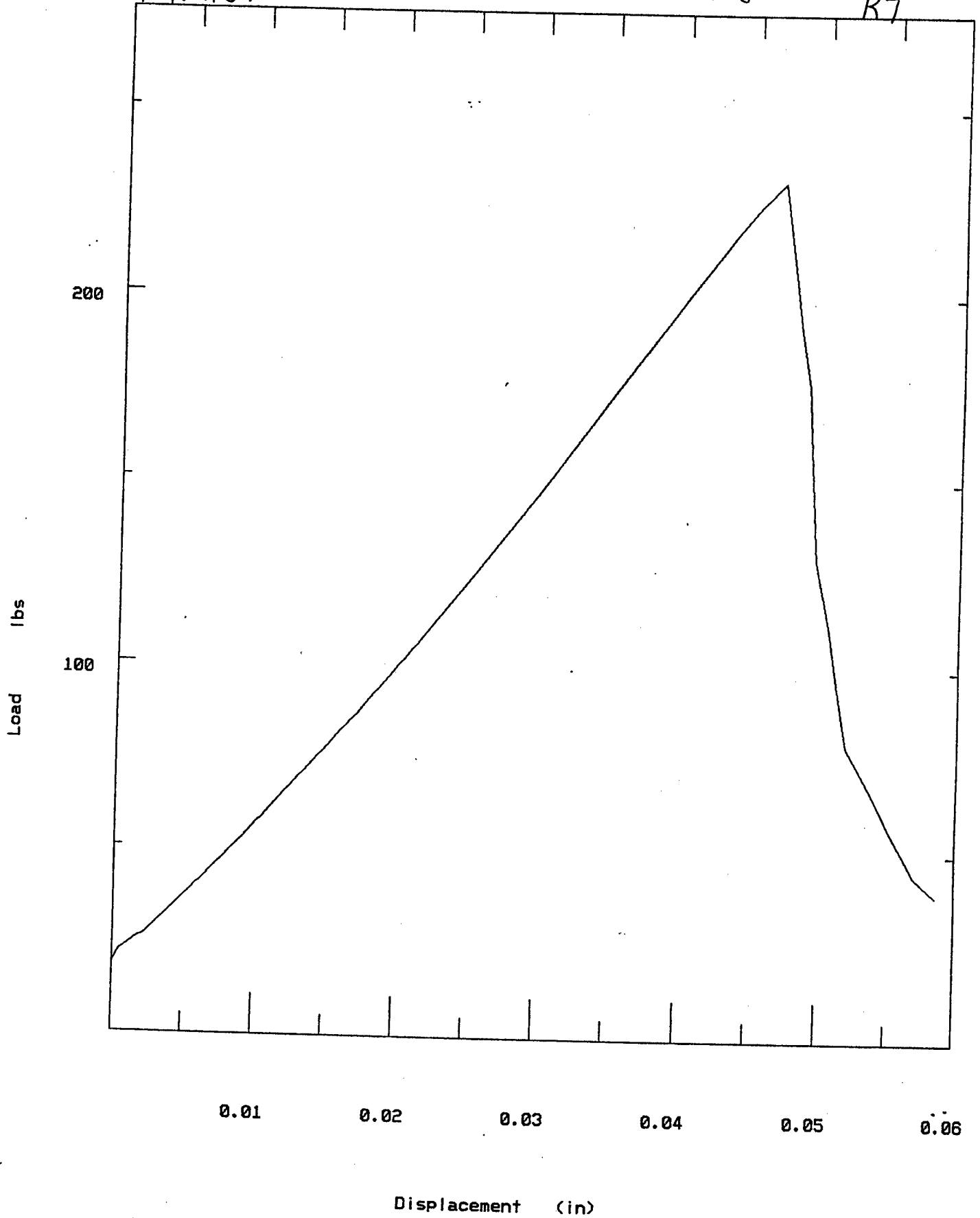

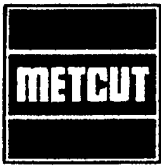

# LABORATORY REPORT

**TO:** Southwest Research Institute  
c/o Chuck Cundiff  
WR-ALC/TIDM, CT10  
450 Third Street  
Suite 200  
Robins AFB, GA 31098

**PROJECT NO:** 635-69997-3

**DATE:** December 22, 1998

**AUTHORIZATION:** 63541

**PROJECT:** Tensile Testing of (25) Spot Welded Specimens Prepared from Material Supplied and Identified by Southwest Research Institute.

Head Rate to Failure: 0.1 In./Min.

Please see the following summary table.

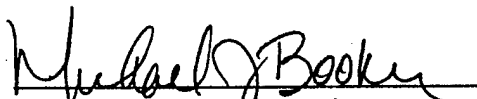
  
Michael J. Booker, Supervisor  
Creep, Stress Rupture & Tensile Testing

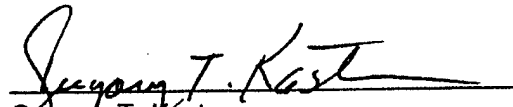
  
Gregory T. Kasten  
Engineering Assistant II

**TENSILE DATA SUMMARY**

Metcut Test Number	Specimen I.D.	Max. Load (lbs.)	Process Condition	SOD
T-122339	4	71	As Received	--
T-122340	5	68	As Received	--
T-122341	8	63	As Received	--
T-122342	14	68	As Received	--
T-122343	15	66	As Received	--
T-122344	20	74	Zero Dwell	Normal
T-122345	23	75	Zero Dwell	Normal
T-122346	25	73	Zero Dwell	Normal
T-122347	27	68	Zero Dwell	Normal
T-122348	31	68	Zero Dwell	Normal
T-122349	30	62	Zero Dwell	0.5 Normal
T-122350	32	68	Zero Dwell	0.5 Normal
T-122351	35	77	Zero Dwell	0.5 Normal
T-122352	37	74	Zero Dwell	0.5 Normal
T-122353	40	57	Zero Dwell	0.5 Normal
T-122354	1	55	Zero Dwell	0.33 Normal
T-122355	3	72	Zero Dwell	0.33 Normal
T-122356	34	73	Zero Dwell	0.33 Normal
T-122357	38	72	Zero Dwell	0.33 Normal
T-122358	41	36 (a)	Zero Dwell	0.33 Normal
T-122359	10	67	2 Dwell	Normal
T-122360	12	69	2 Dwell	Normal
T-122361	16	68	2 Dwell	Normal
T-122362	18	74	2 Dwell	Normal
T-122363	21	65	2 Dwell	Normal

**NOTES:** (a) Examination of failure indicated that low value was apparently caused by the poor quality of the spot weld.

T-122339

AS-RECD

SPEC # 01 4

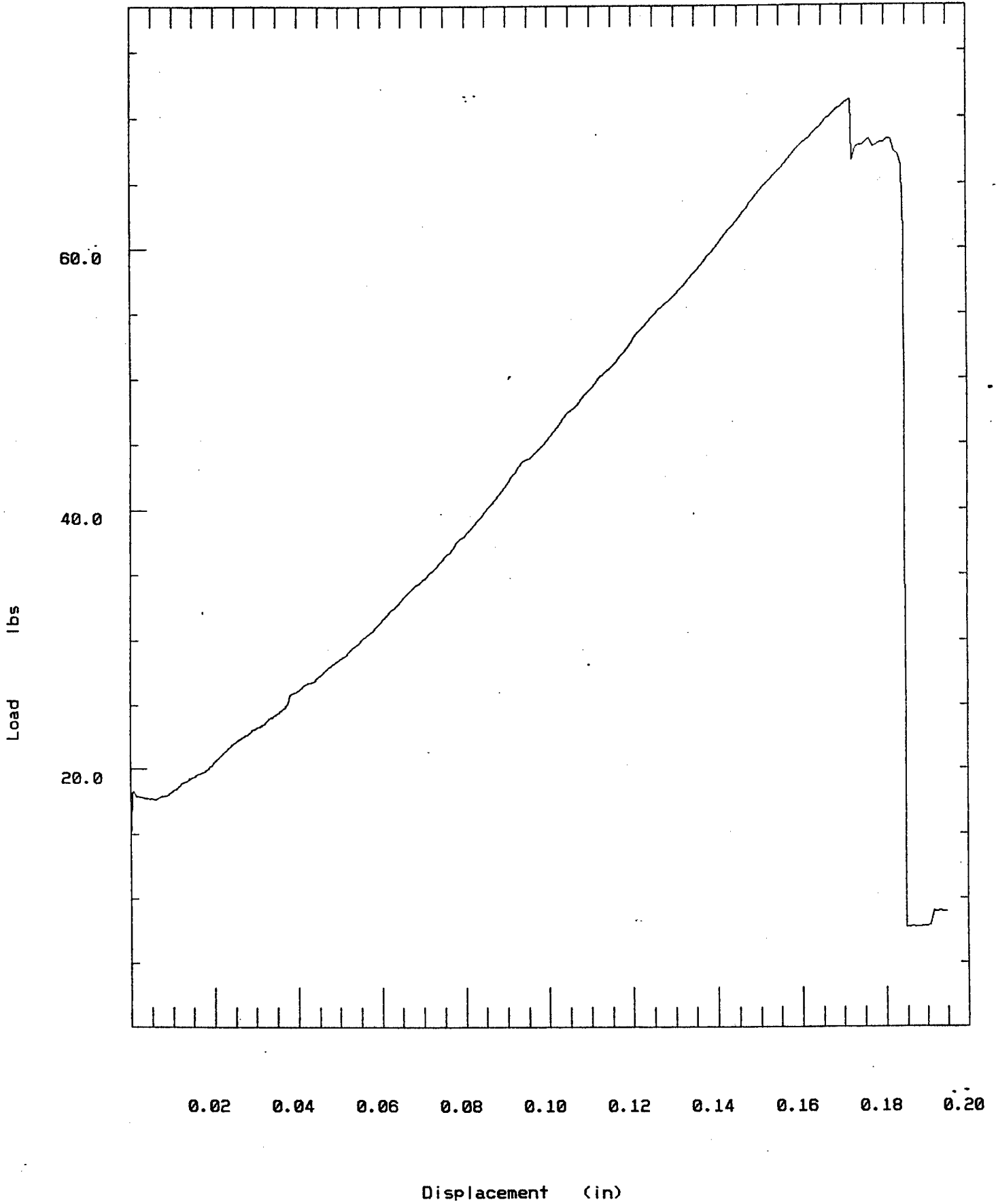

T-122340

AS-RECD

SPEC # 02 5

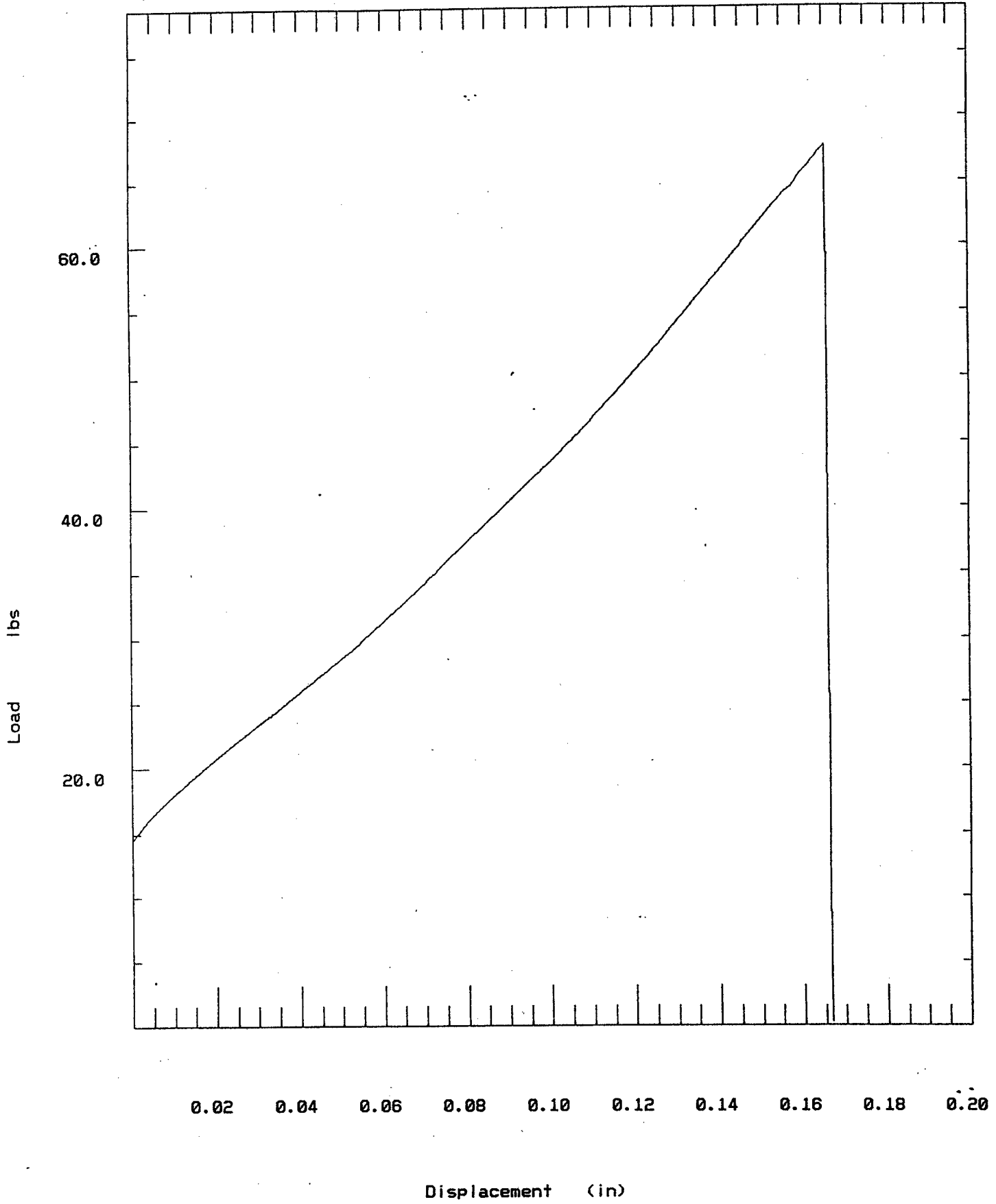

T-122341

AS-RECD

SPEC # 03 8

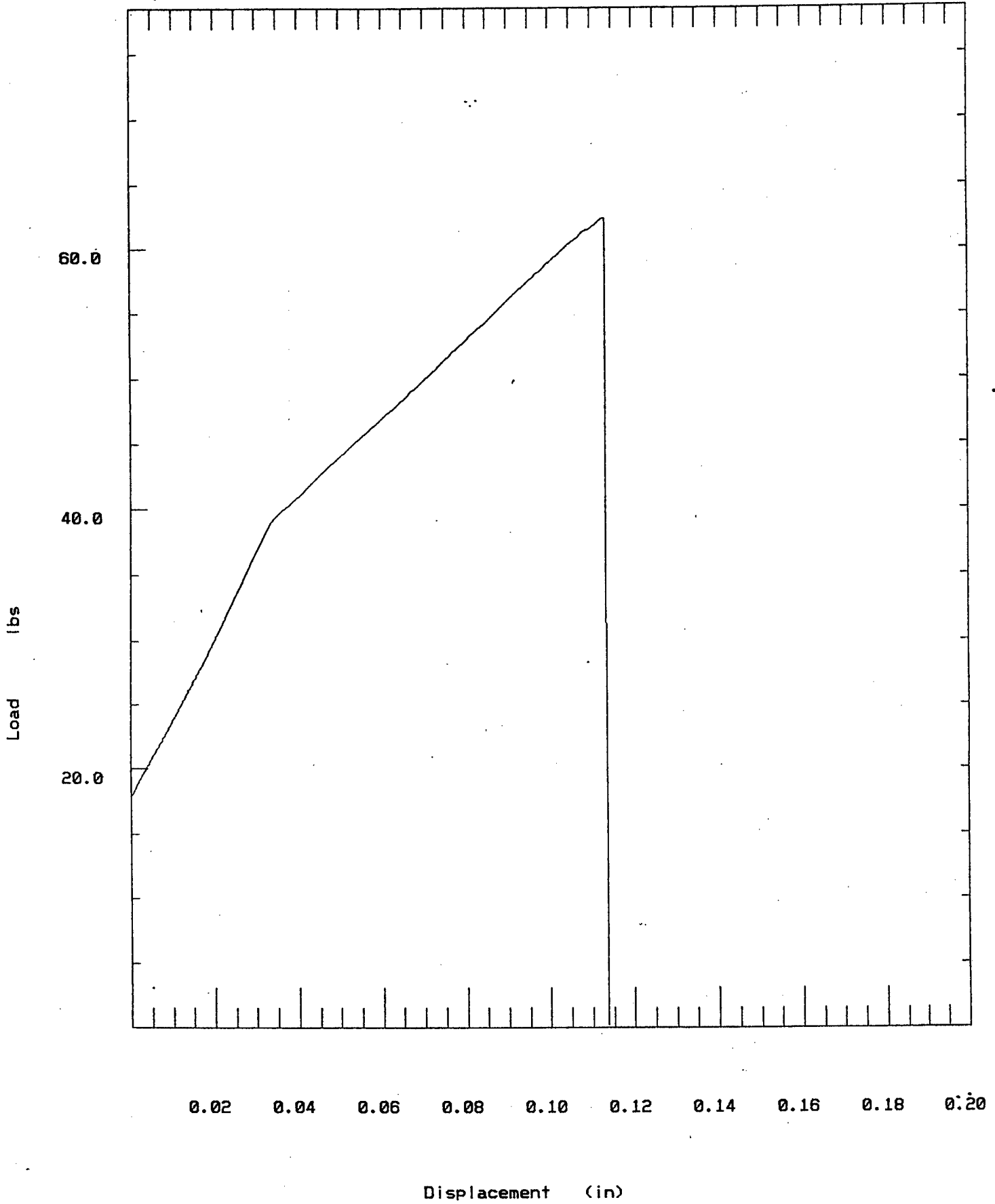

T-122342

AS-RECD

SPEC # 0414

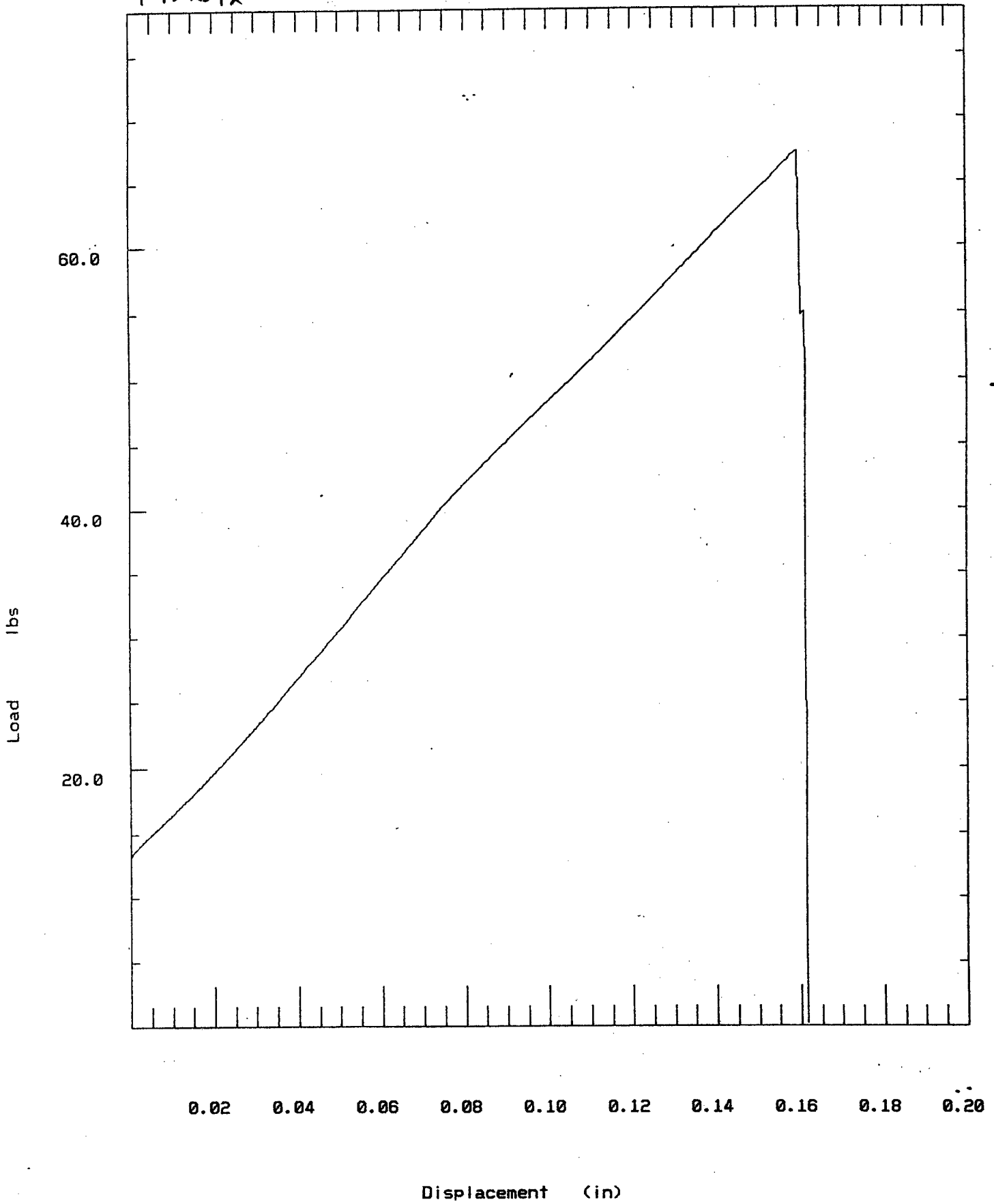

T-122343

AS-RECD

SPEC # 05/15

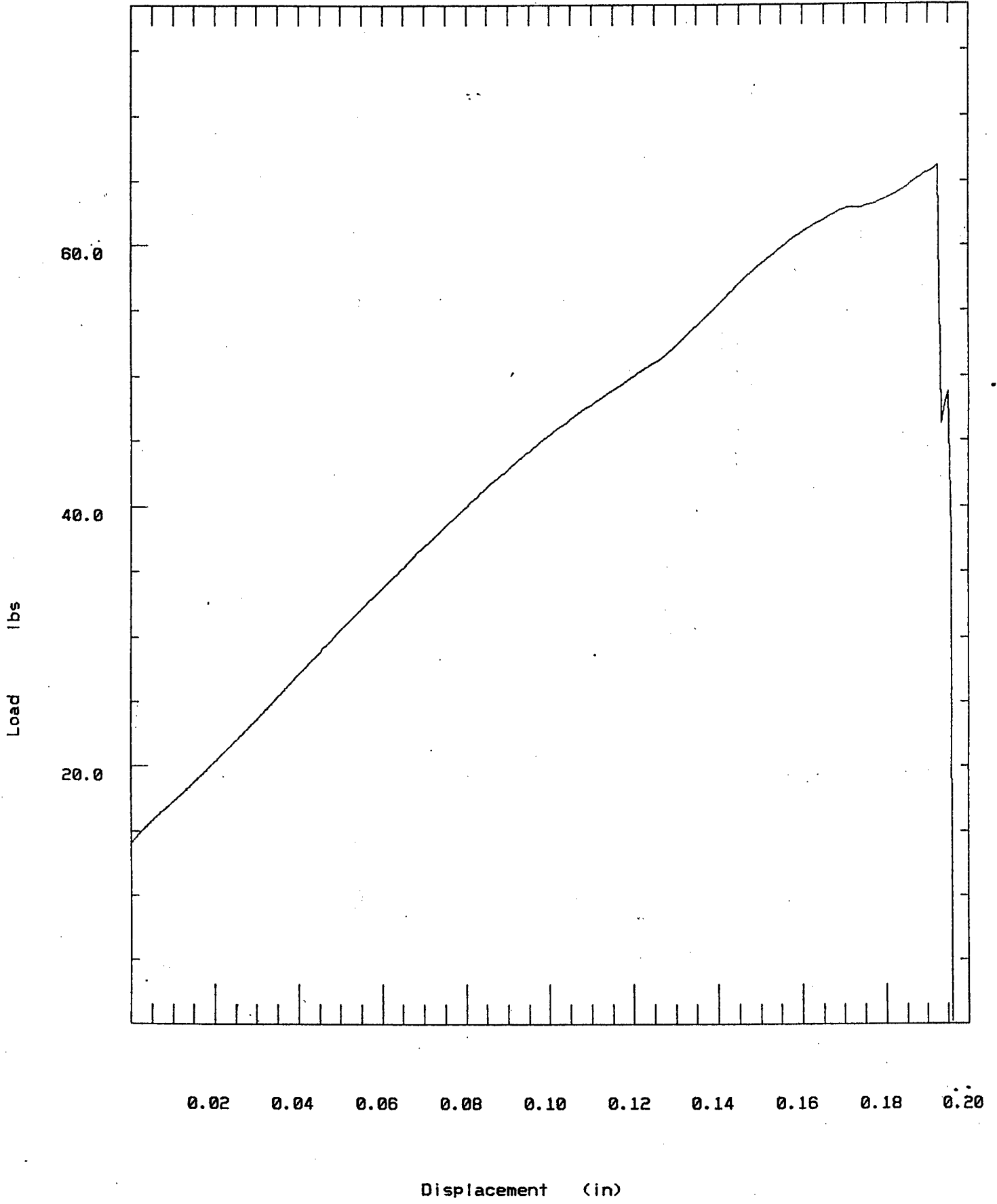

T-122344

ZD-NOR

SPEC # 0120

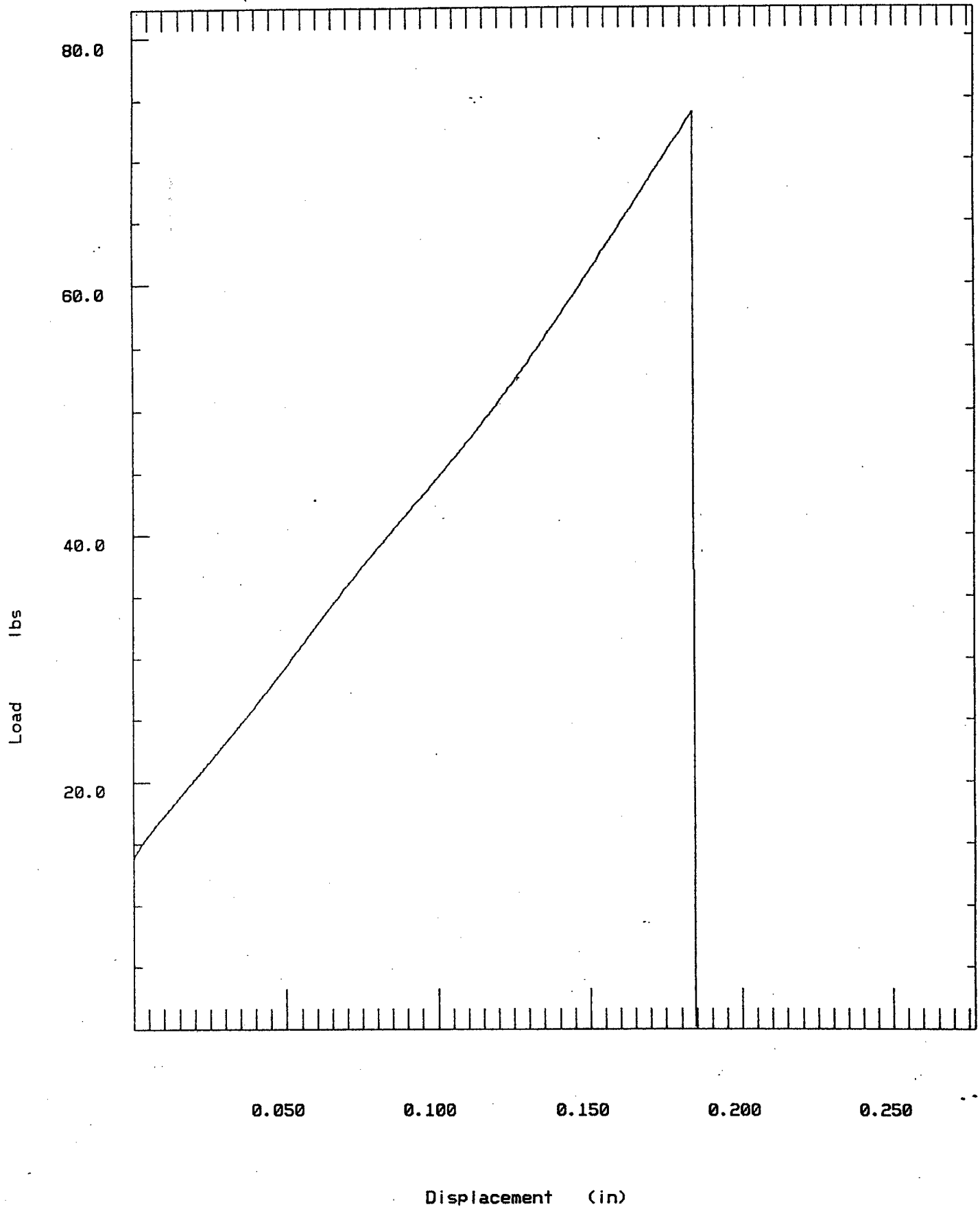

T-122345

ZD-NOR

SPEC # 02 23

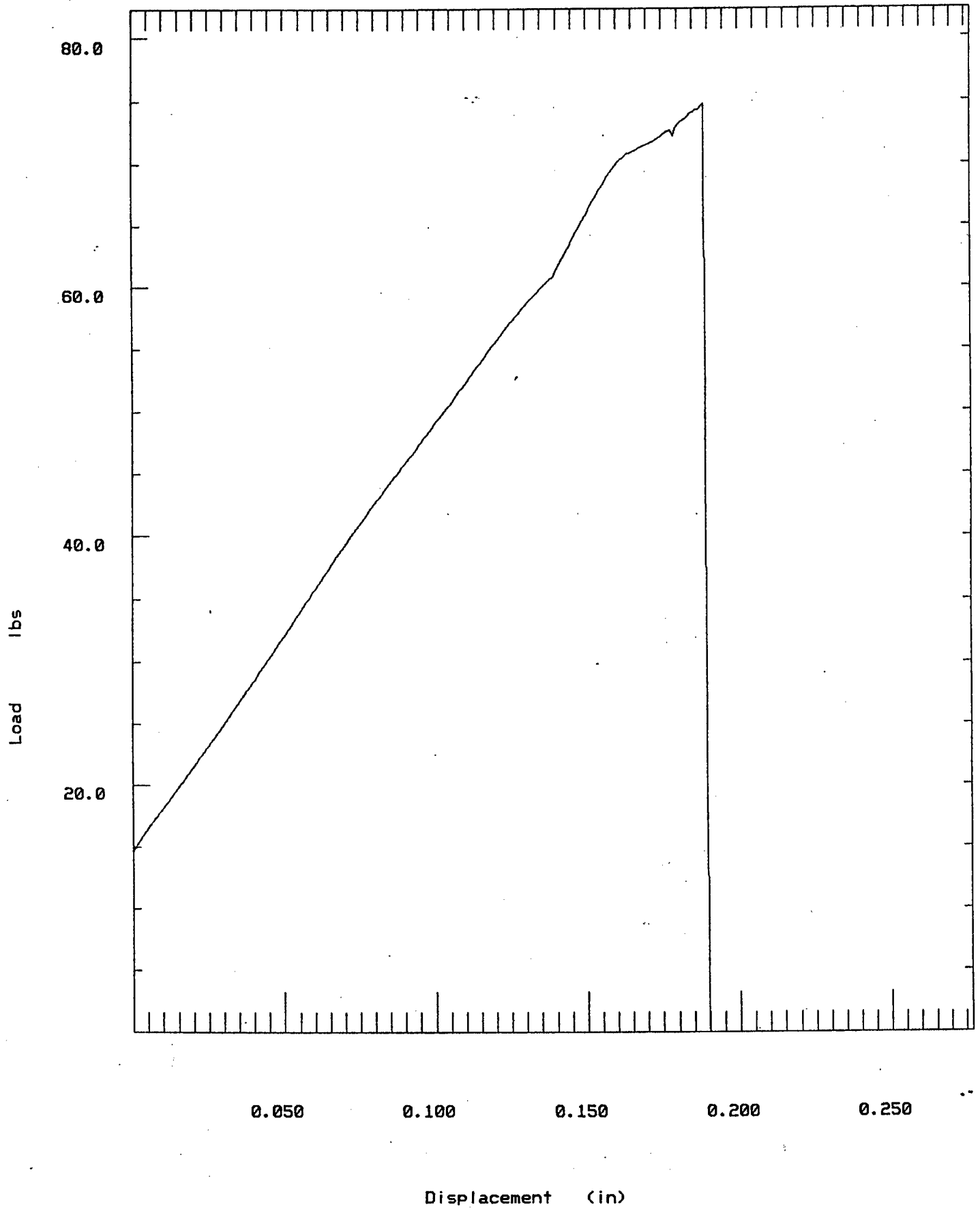

T-122346

ZD-NOR

SPEC # 0925

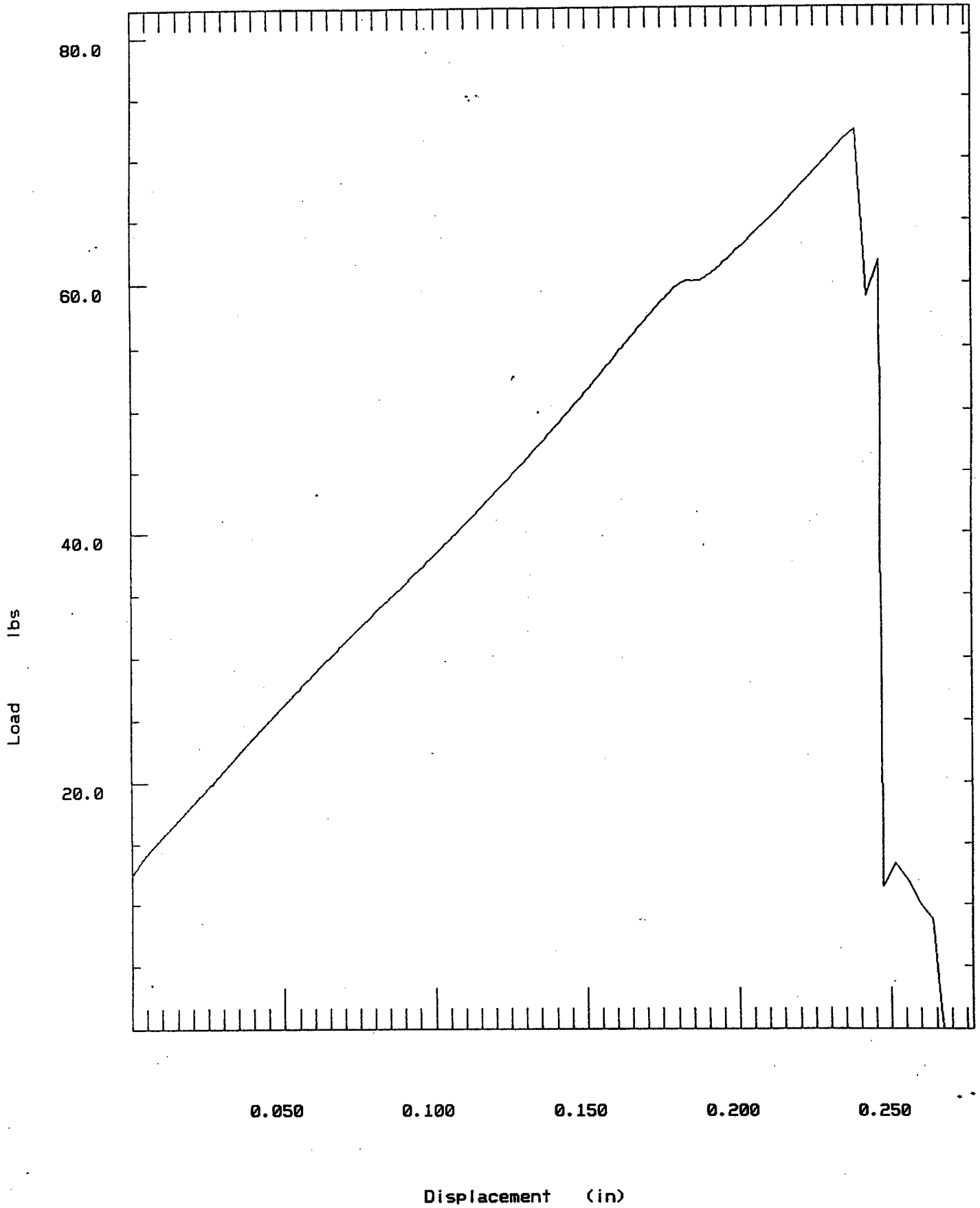

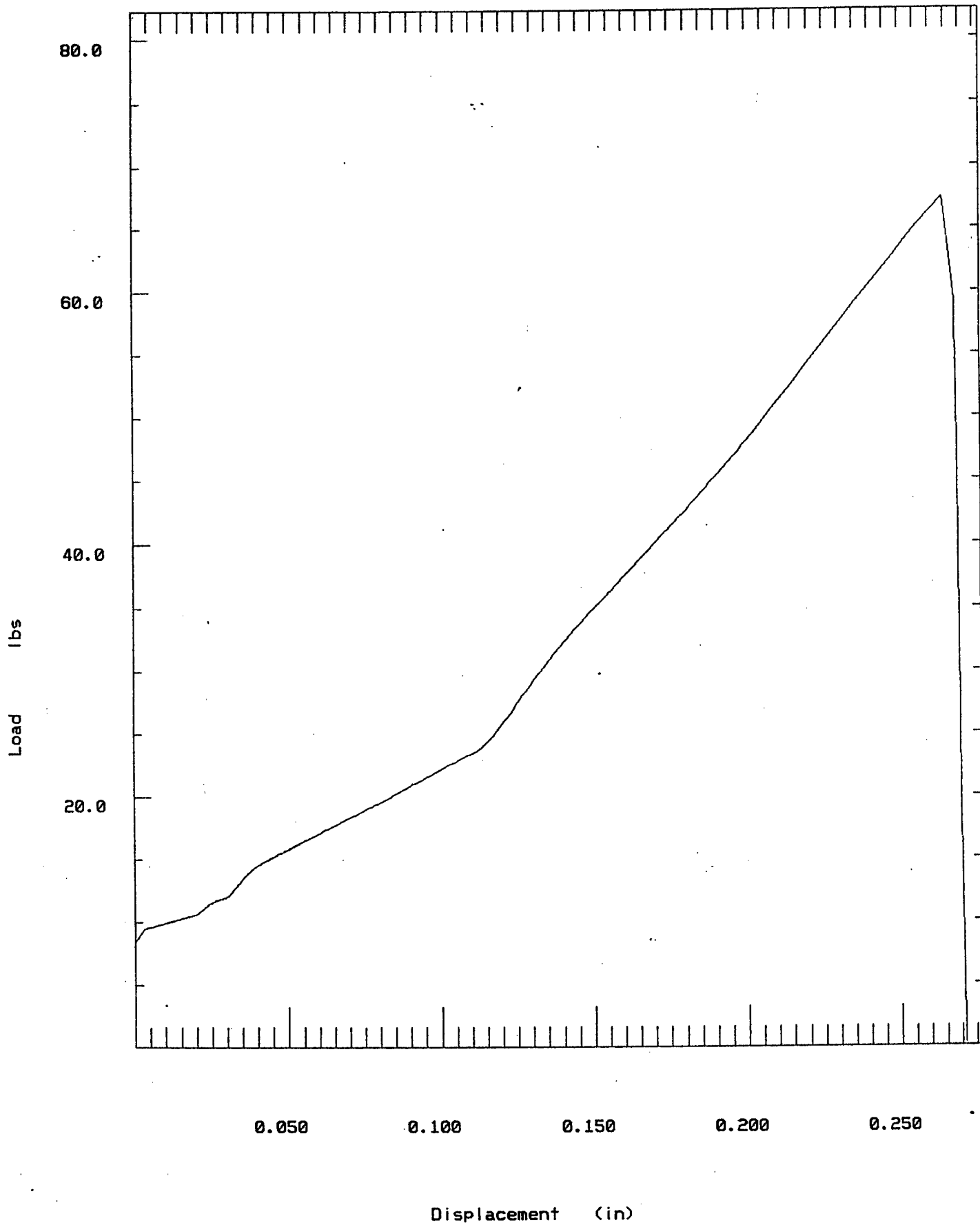

T-122348

ZD-NOR

SPEC # 05-31

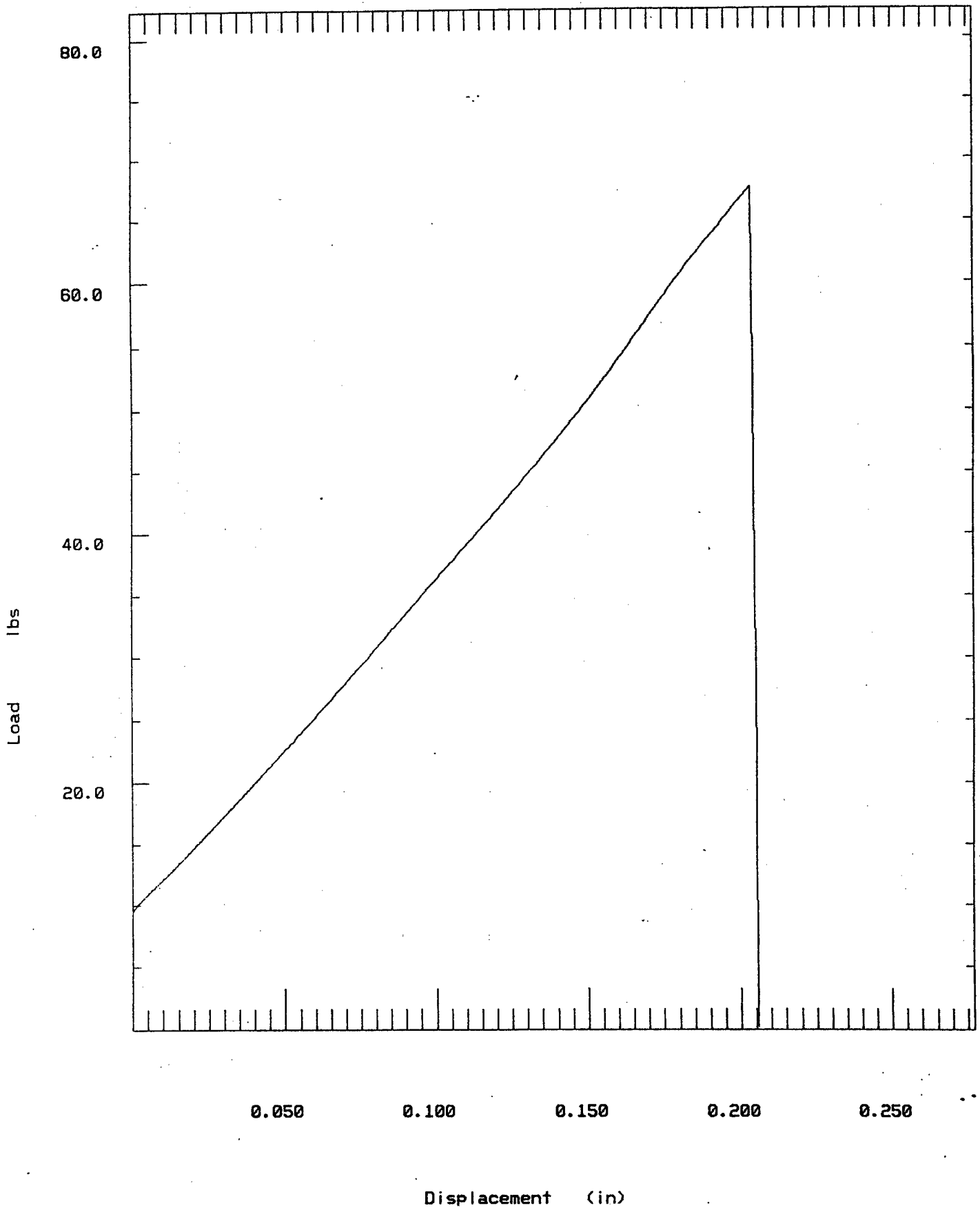

T-122349

ZD05NOR

SPEC # 01 30

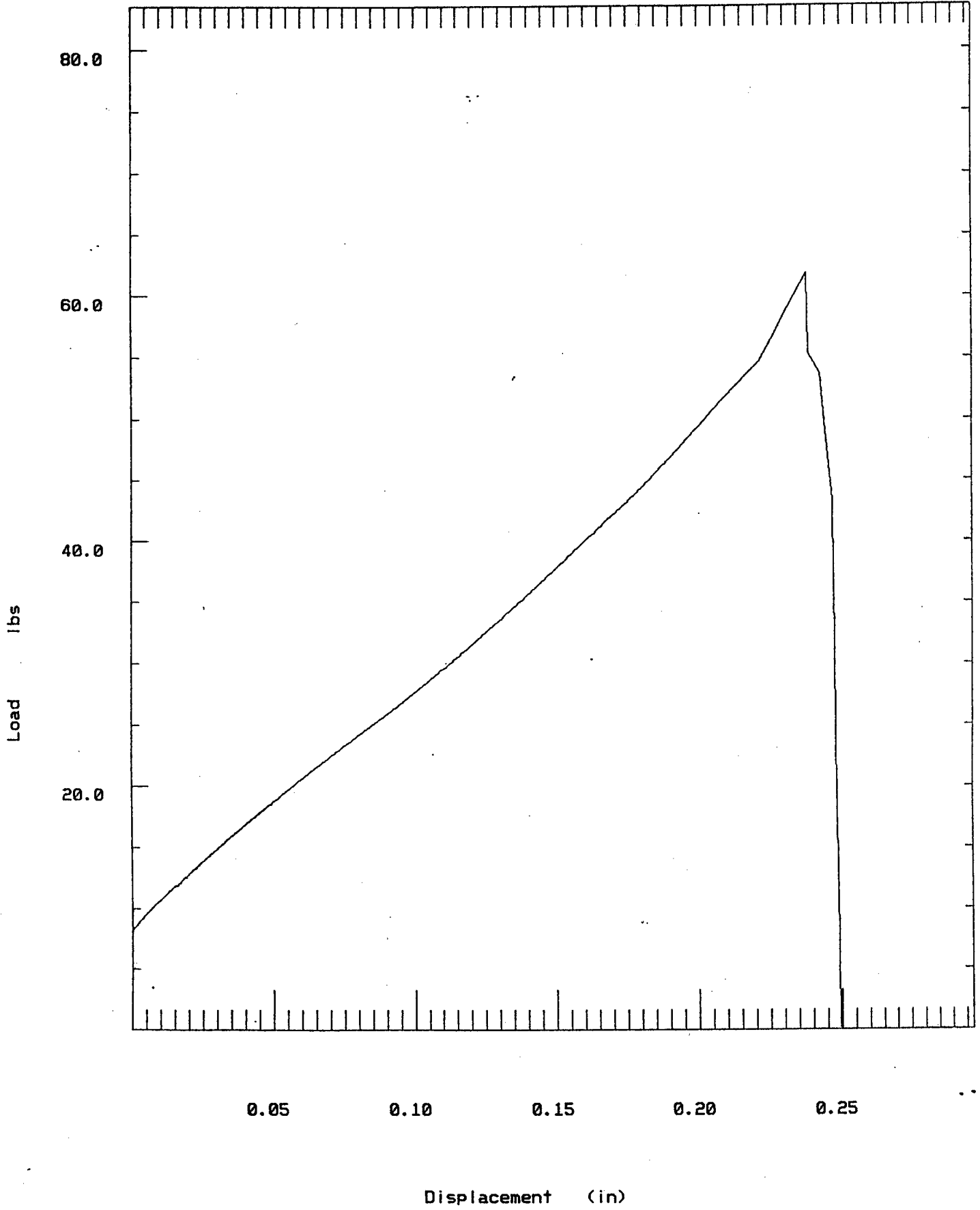

T-122350

ZD05NOR

SPEC # 02 32

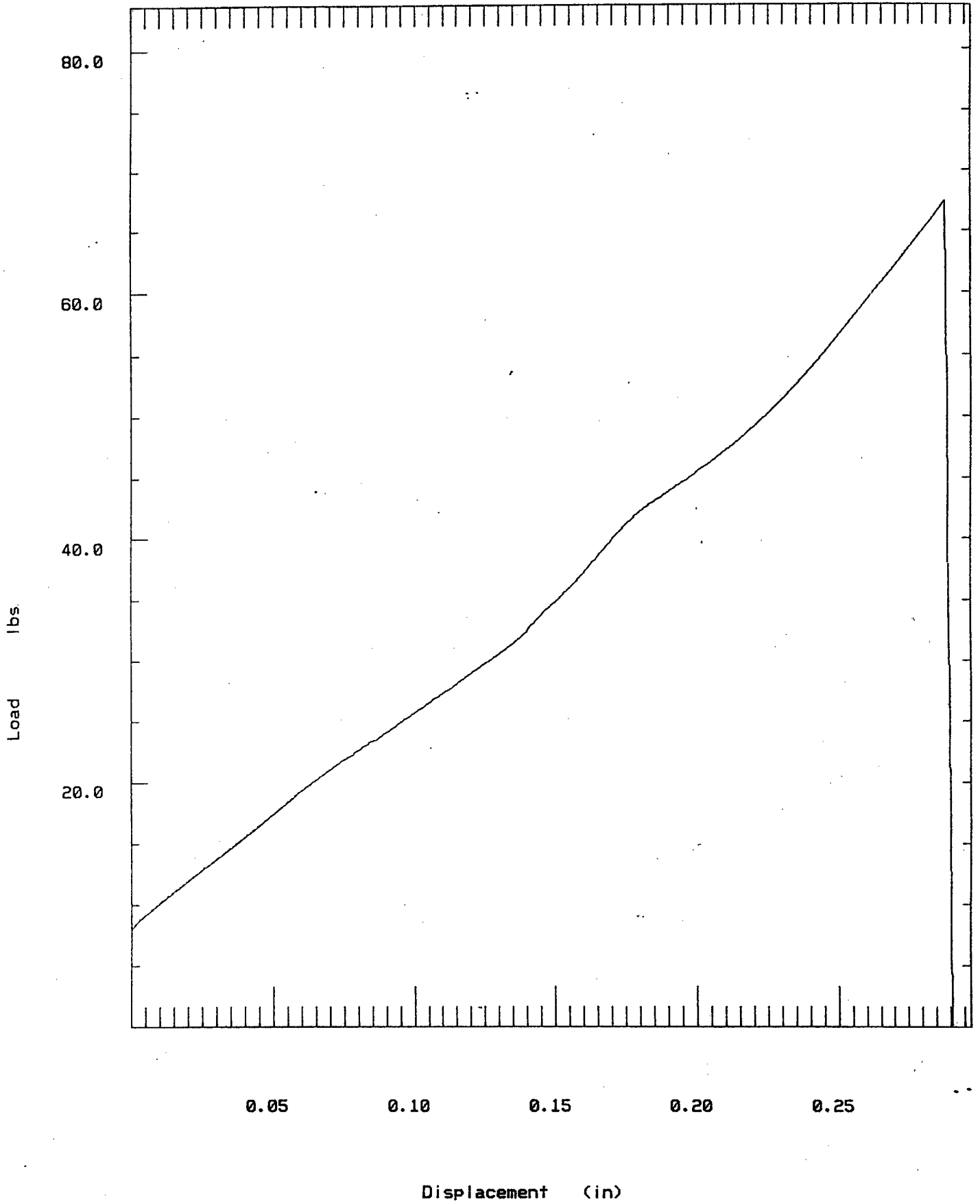

T-122351

ZD05NOR

SPEC # 03 J5

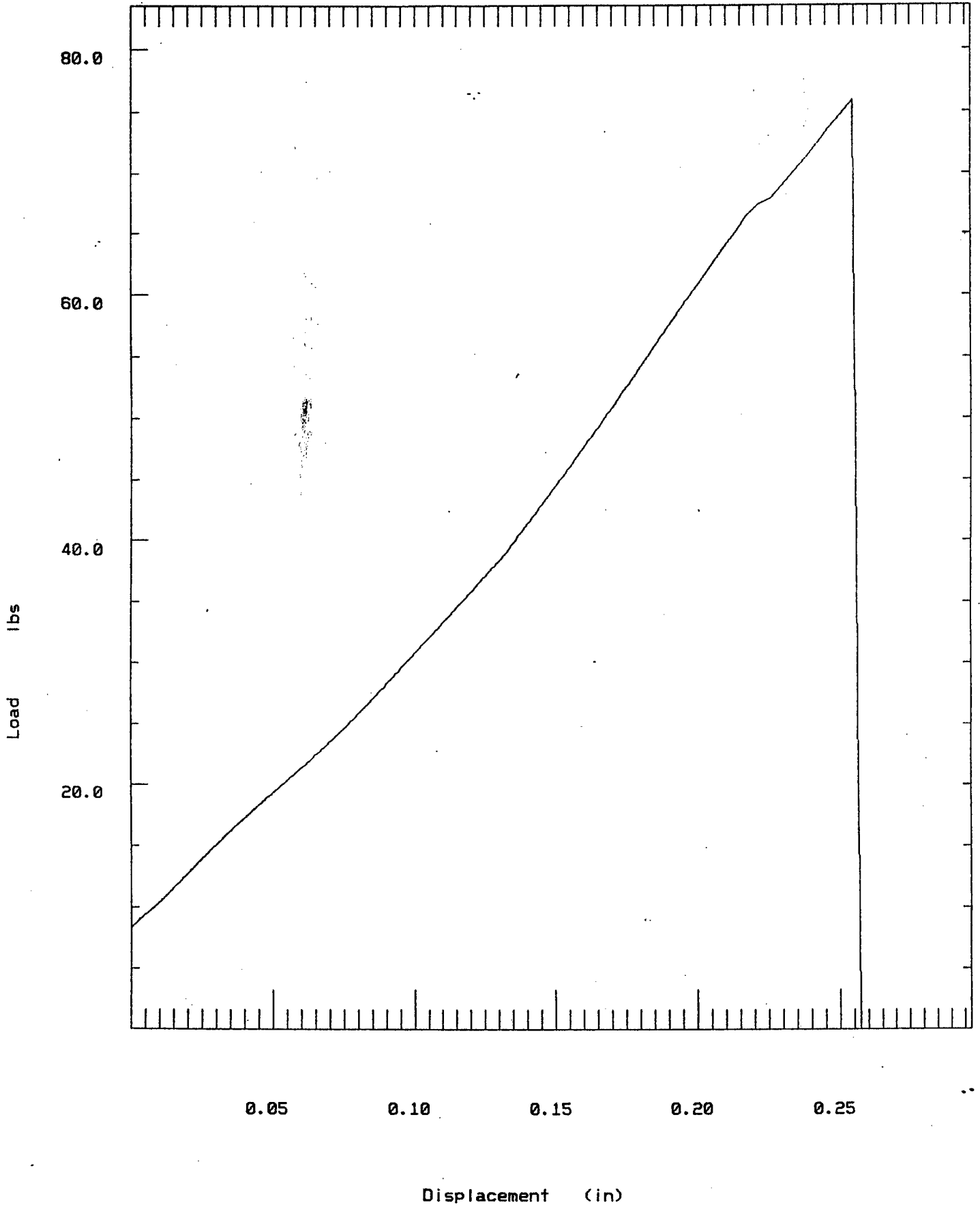

T-122352

ZD05NOR

SPEC # 0437

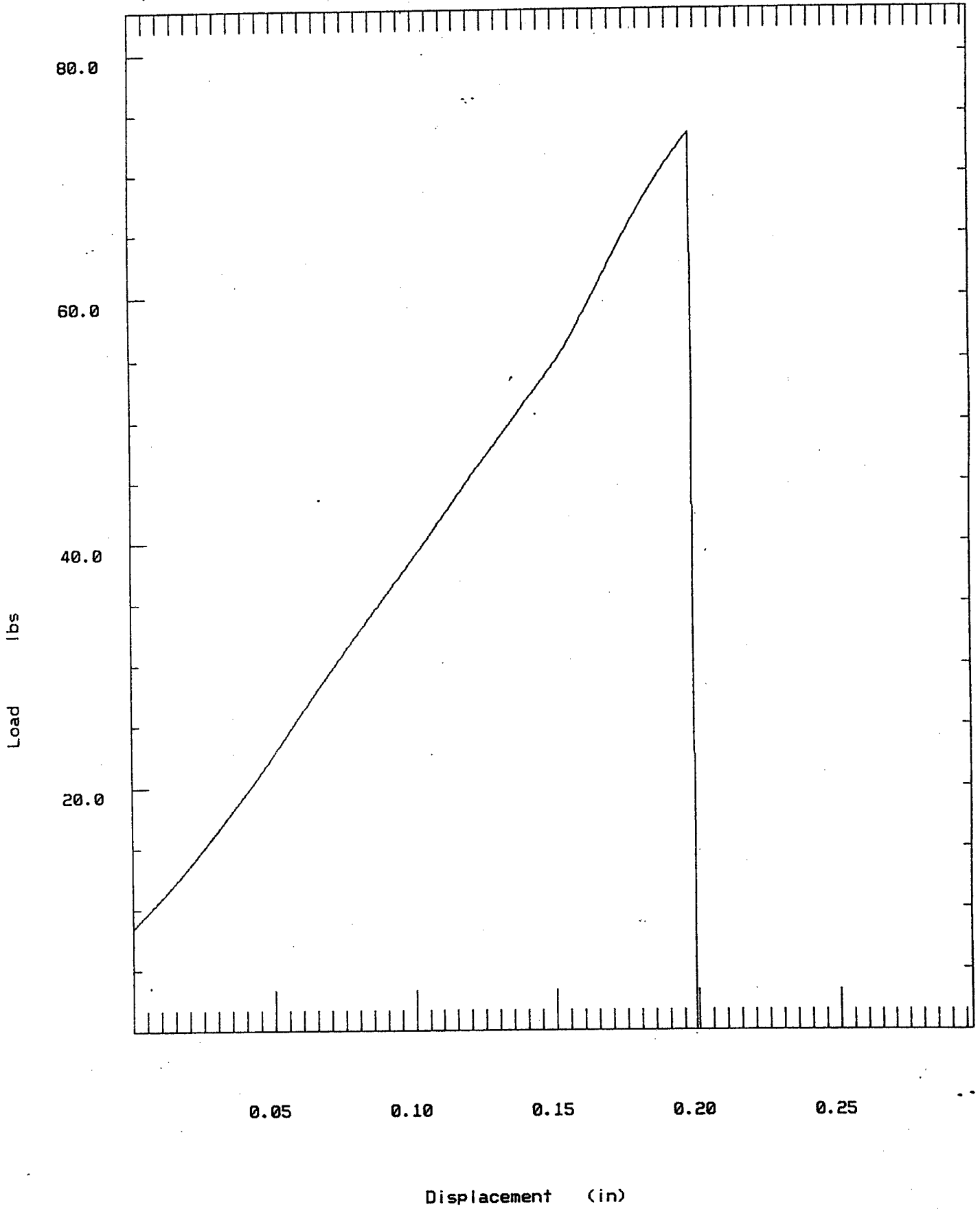

T-122353

ZD05NOR

SPEC # 0540

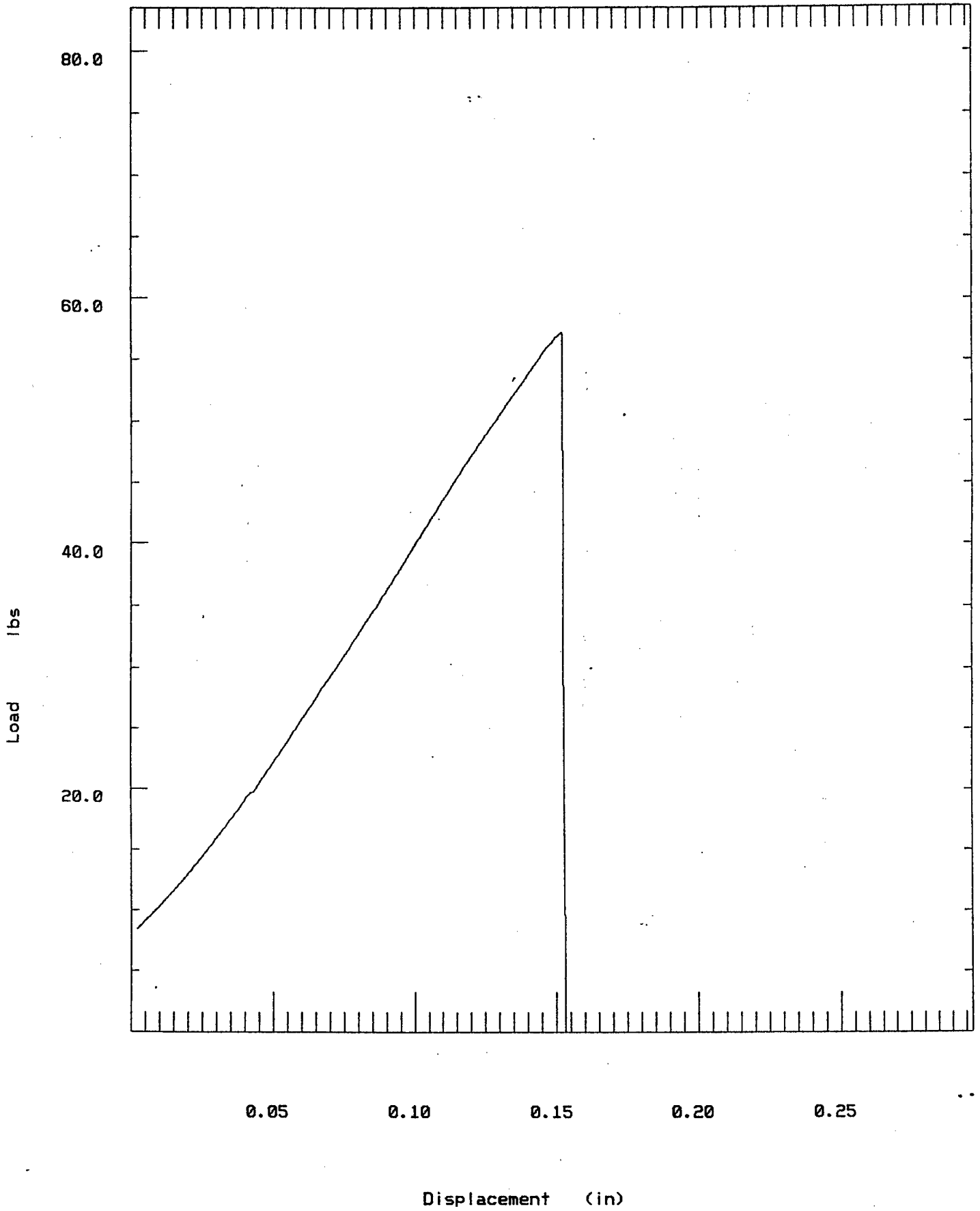

T-122354

ZD033NOR

SPEC # 01

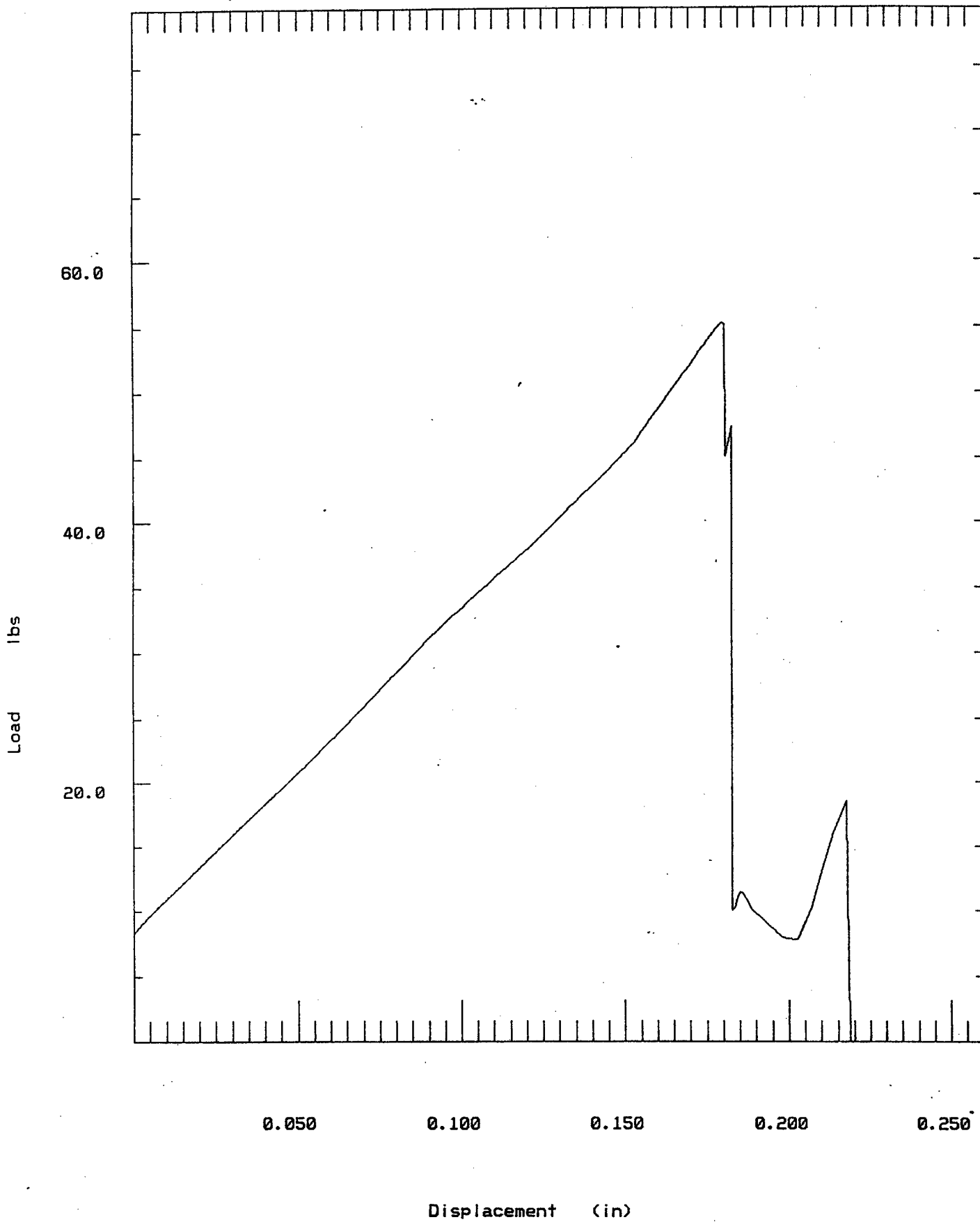

T-12455

ZD033NOR

SPEC # 023

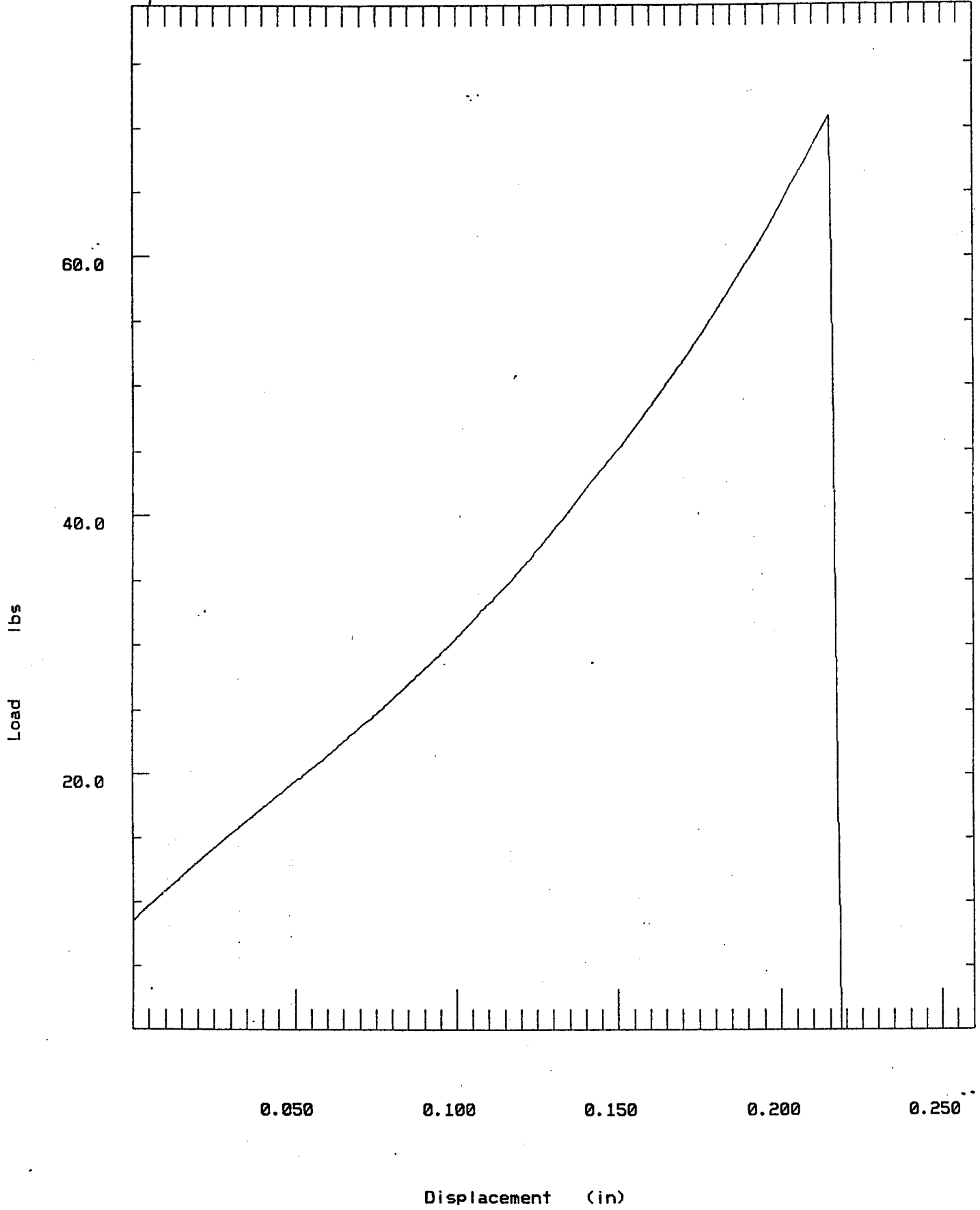

T-12256

ZD033NOR

SPEC # 0334

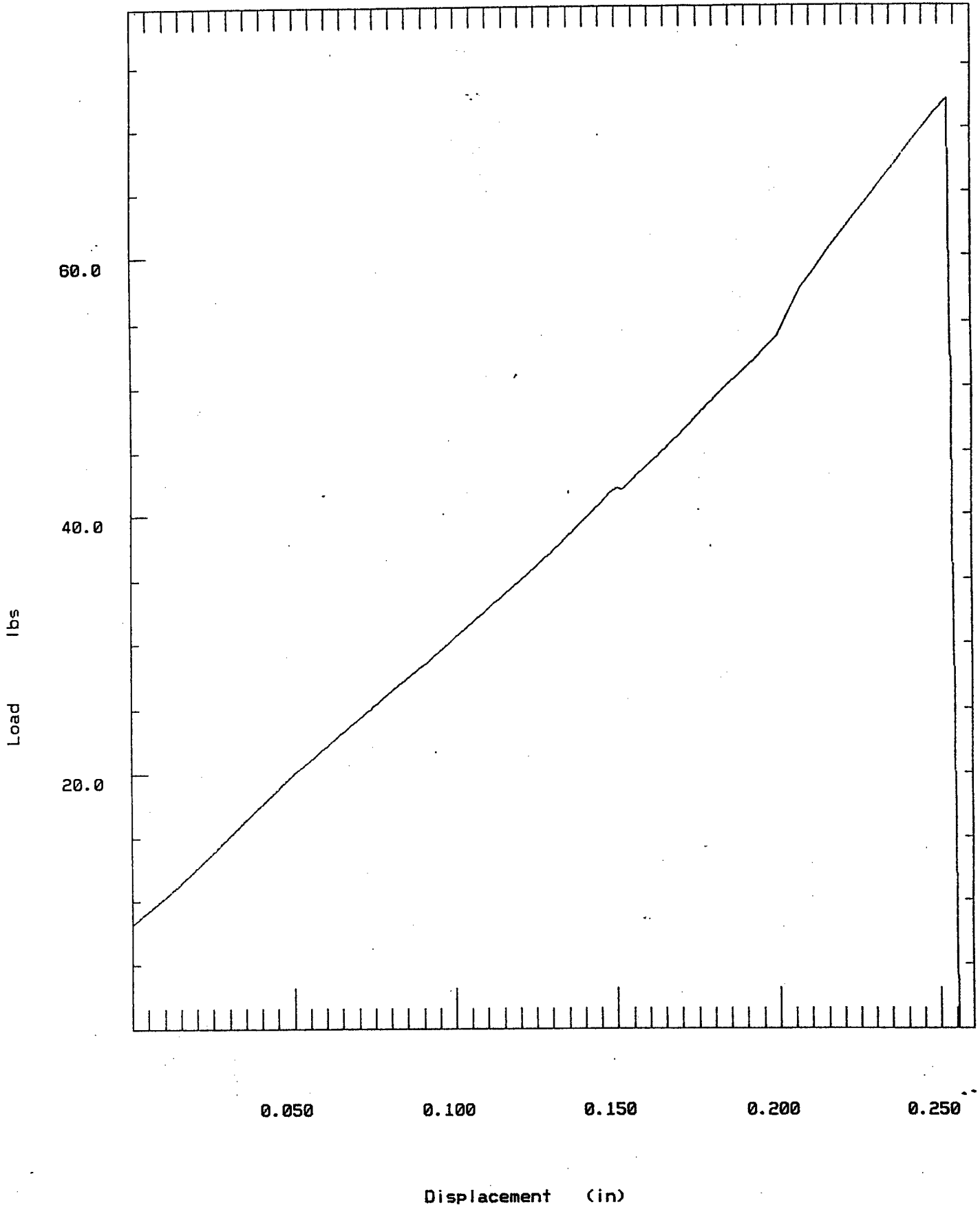

T-122357

ZD033NOR

SPEC # 0438

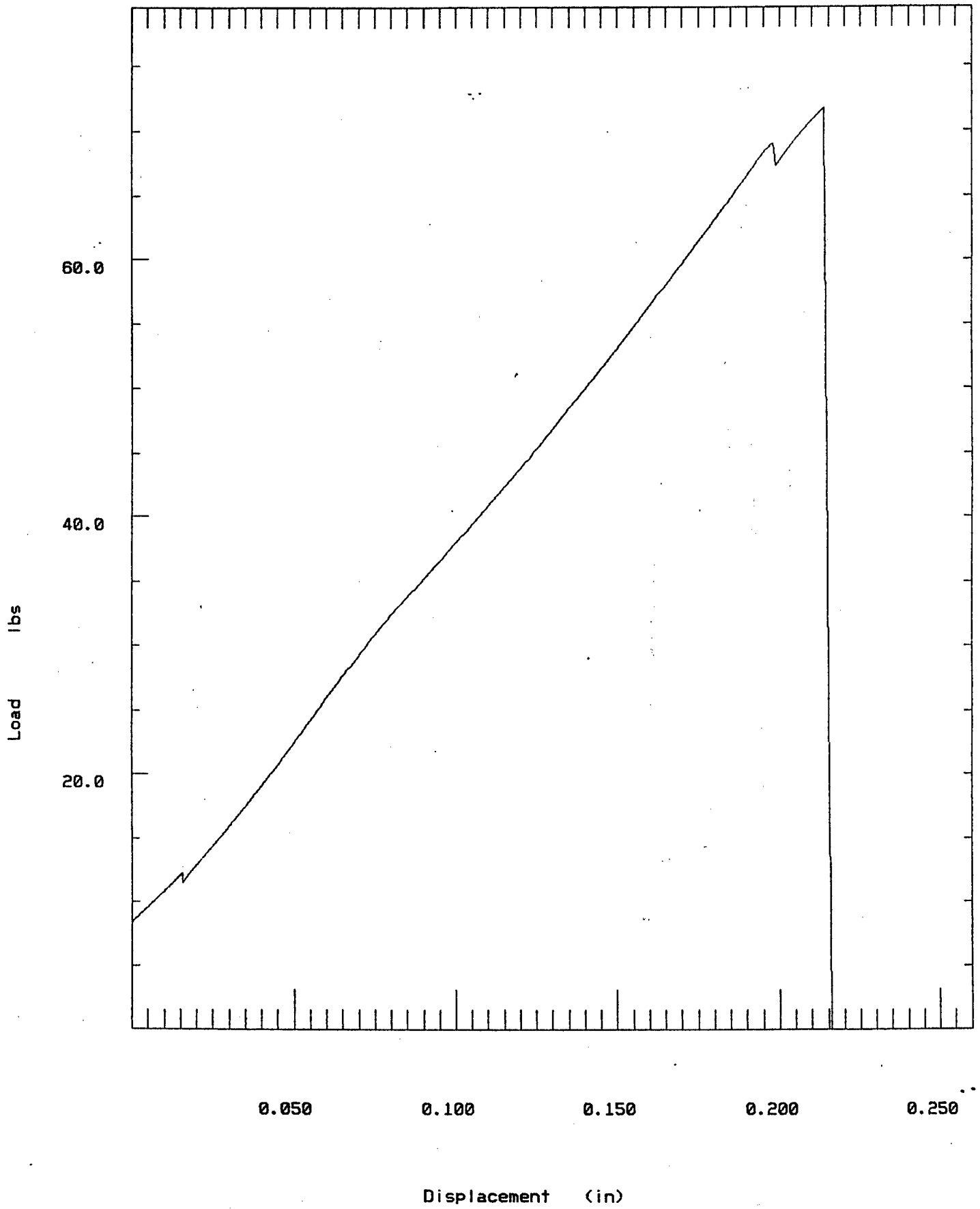

T-122558

ZD033NOR

SPEC # 0541

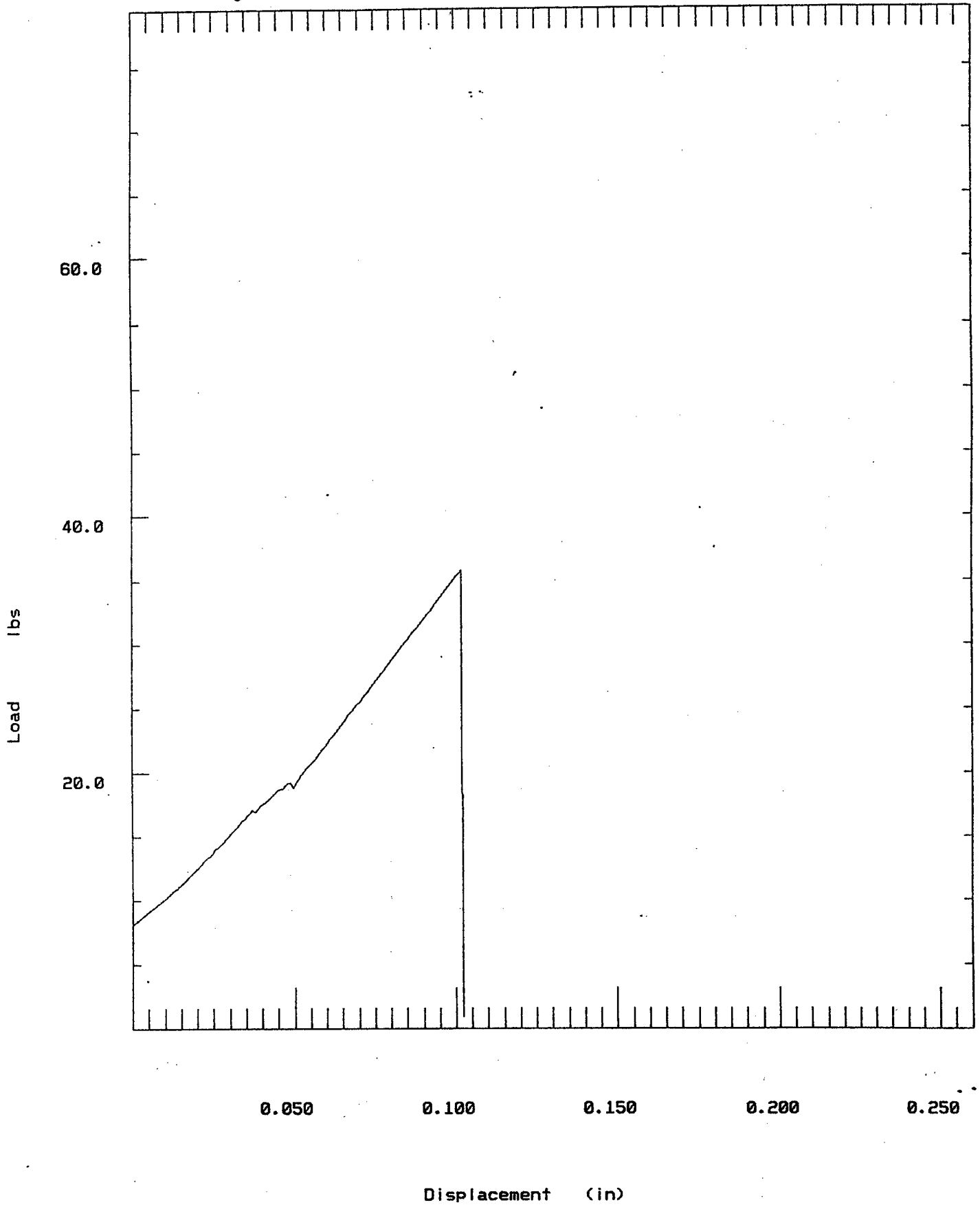

T-122359

2D-NORM

SPEC # 0±10

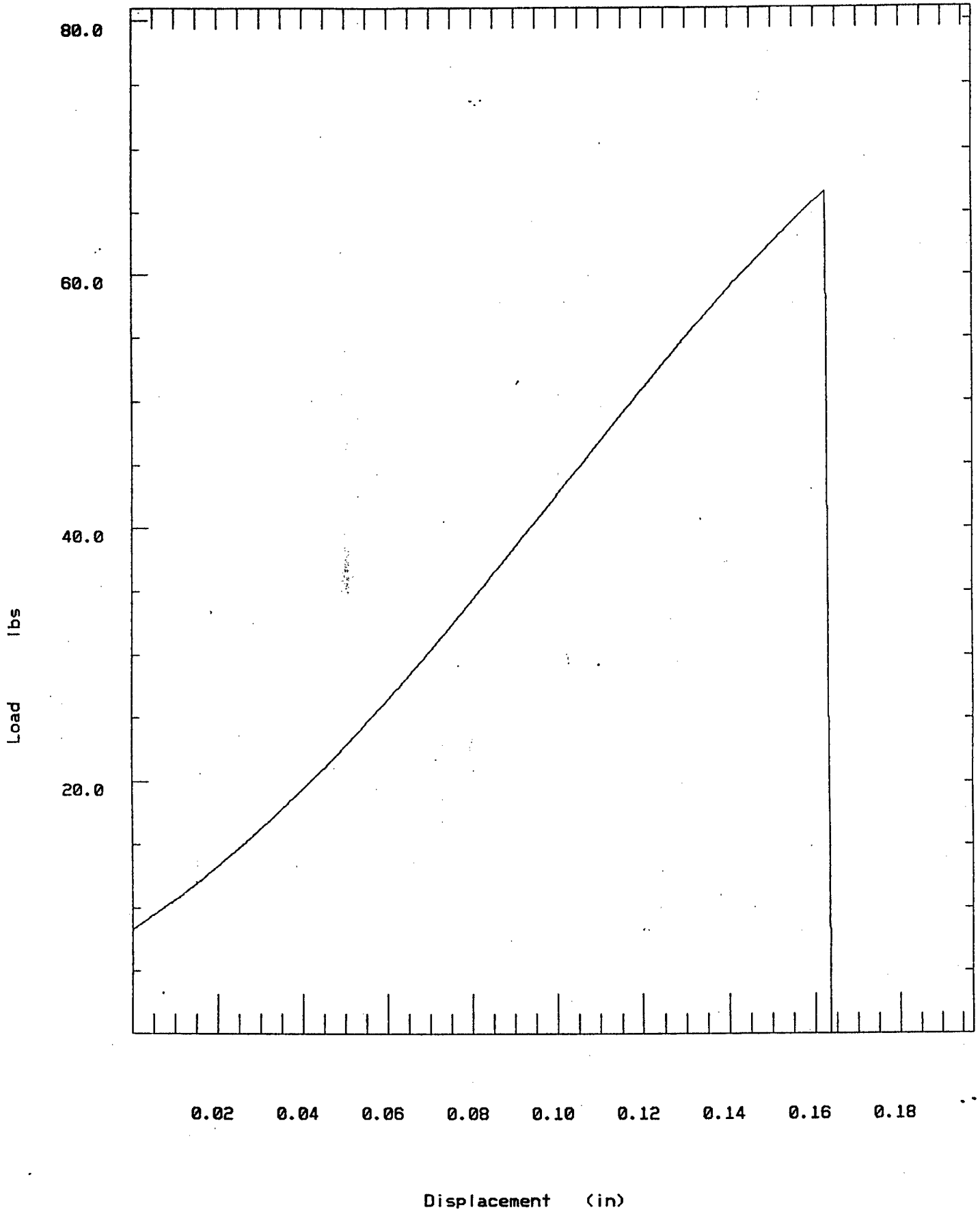

T-122360

2D-NORM

SPEC # 0212

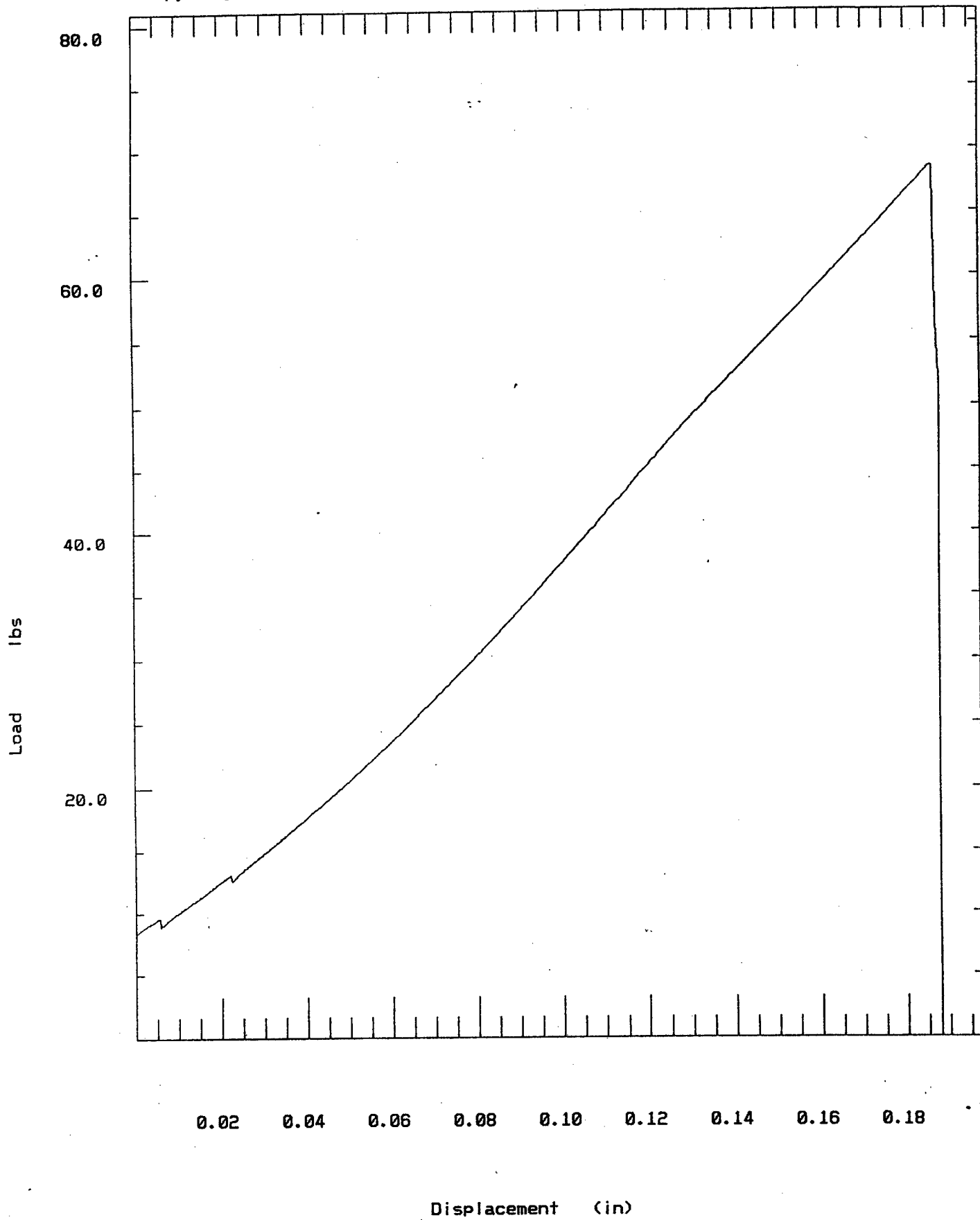

T-122361

2D-NORM

SPEC # 03-16

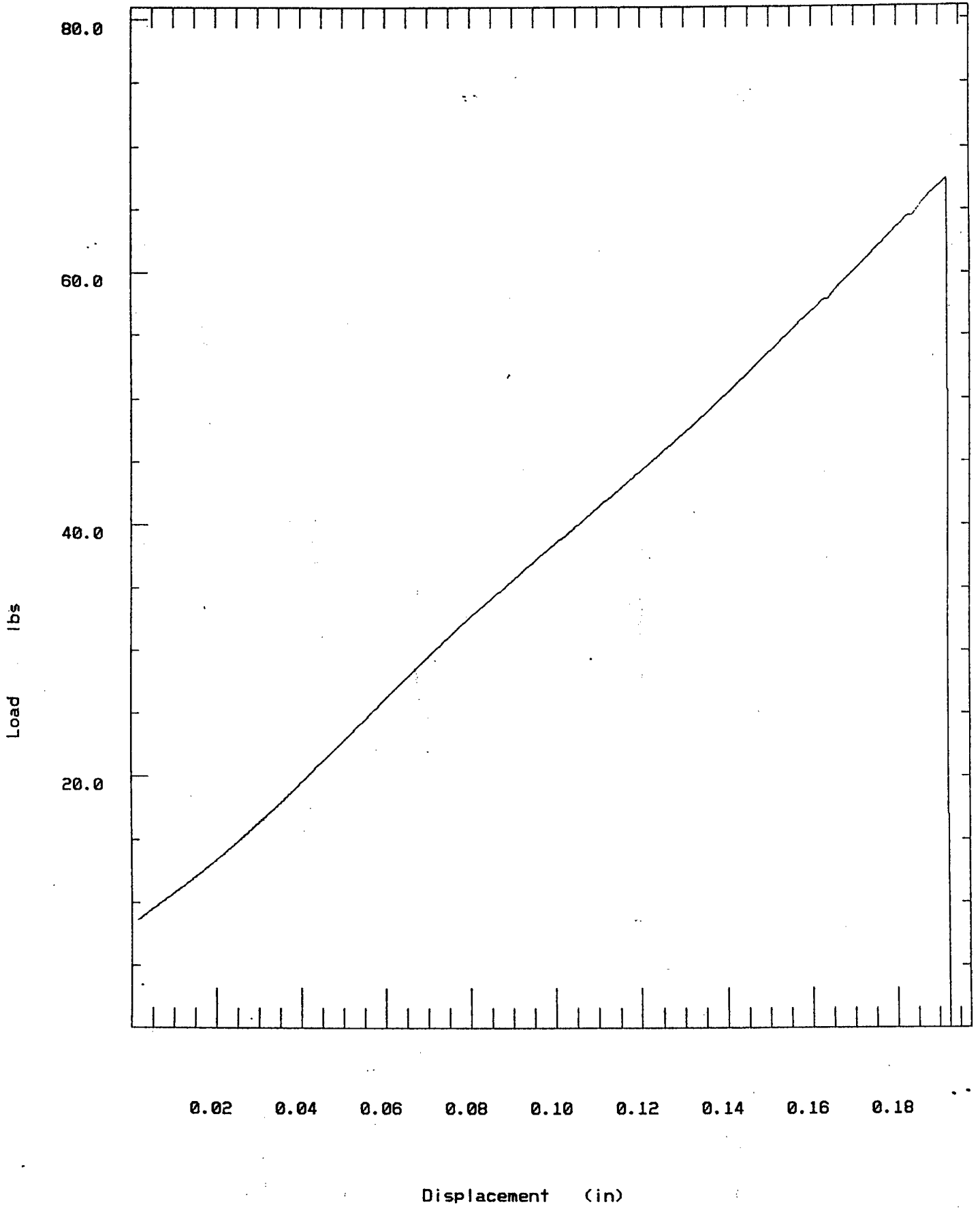

T-122362

2D-NORM

SPEC # 0418

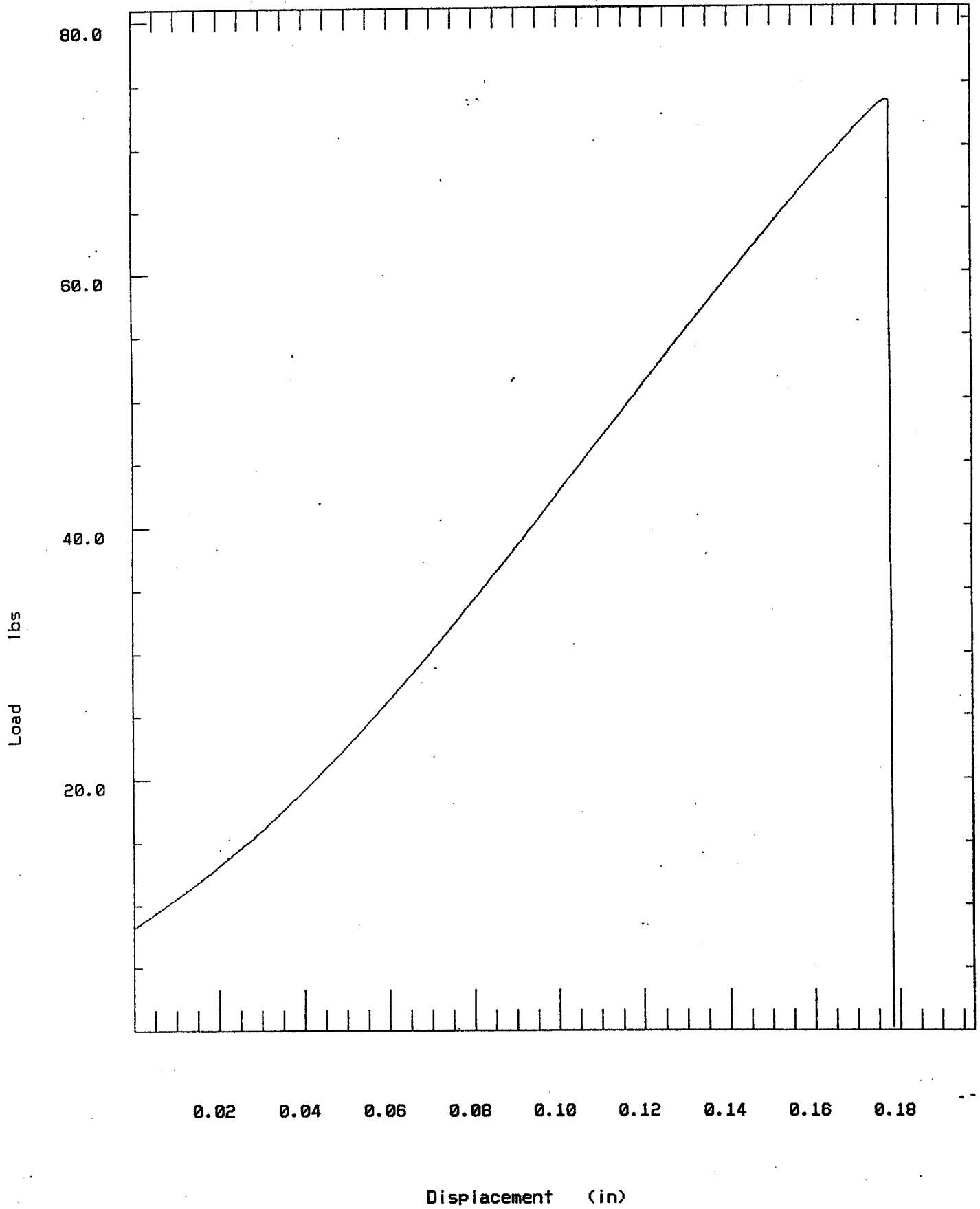

T-122363

2D-NORM

SPEC # 05 21

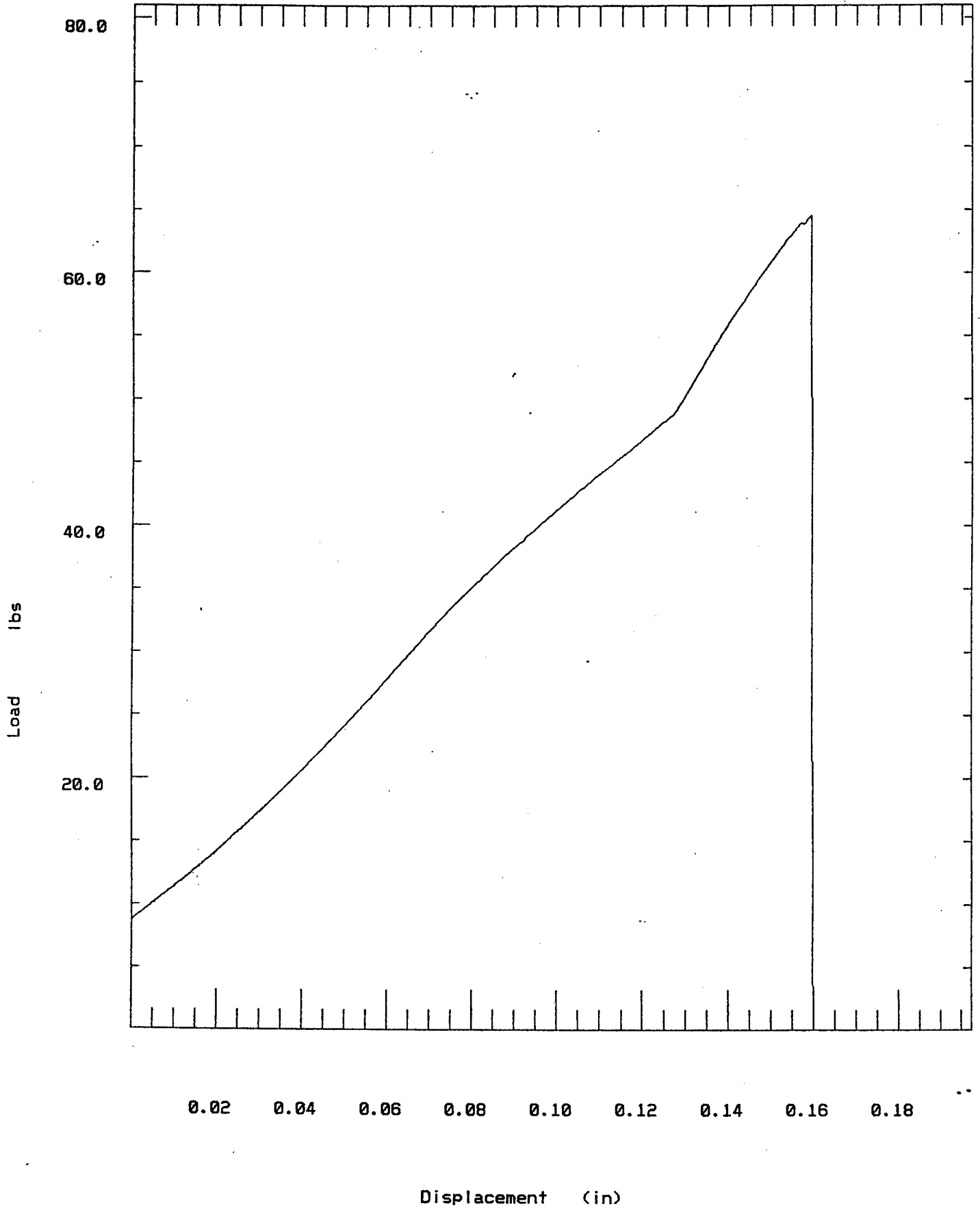

## **APPENDIX B**

### **STATISTICAL ANALYSIS OF LOW CYCLE FATIGUE and SPOT WELD STRENGTH TESTS**

## STATISTICAL ANALYSIS OF LOW CYCLE FATIGUE and SPOT WELD STRENGTH TESTS

### I. BACKGROUND - ANALYSIS

Data were collected on test specimens under four different testing scenarios: (1) face sheet low cycle fatigue @ 100kcycles, (2) spot weld low cycle fatigue @ 100kcycles, (3) spot weld tensile-shear strength, and (4) spot weld tensile strength. Data from each of these four test conditions were analyzed independently using analysis of variance (ANOVA) statistical techniques. Each ANOVA compared the average response, i.e. fatigue life or maximum load, of the control group to the average response of the test groups within the selected testing scenario. A Tukey HSD multiple comparison test was used to determine which test groups were significantly different than the control group. All statistical comparisons were made at the  $\alpha=0.10$  level of significance.

### II. FACE SHEET LOW CYCLE FATIGUE TESTS

Three test groups comprised the face sheet low cycle fatigue tests: control (quantity of specimens,  $n=11$ ), zero dwell at normal SOD ( $n=9$ ), and zero dwell at 0.5 normal SOD ( $n=10$ ). The one-factor analysis of variance indicated that there were significant differences in the average cycles among the three test groups ( $p\text{-value}=0.0094$ ). The Tukey HSD comparison test indicated that there was a significant difference in the average cycles for the control and zero dwell at normal SOD. There was not a significant difference in the average cycles comparing the zero dwell at 0.5 normal SOD to the control group. The graph below depicts the means and 90% intervals about the means for each test group.

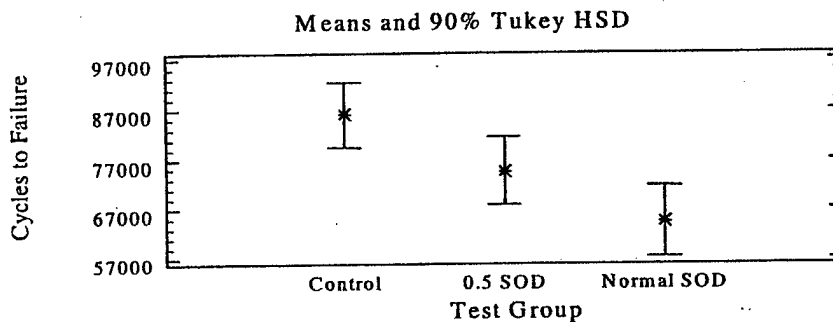

### III. SPOT WELD LOW CYCLE FATIGUE TESTS

Three test groups also comprised the spot weld low cycle fatigue tests @ 100kcycles: control ( $n=11$ ), zero dwell at normal SOD ( $n=10$ ), and zero dwell at 0.5 normal SOD ( $n=10$ ). The one-factor analysis of variance indicated that there was no significant difference in the average number of cycles between the two test groups and the control group

(p-value=0.1319). The graph below depicts the means and 90% intervals about the means for each test group.

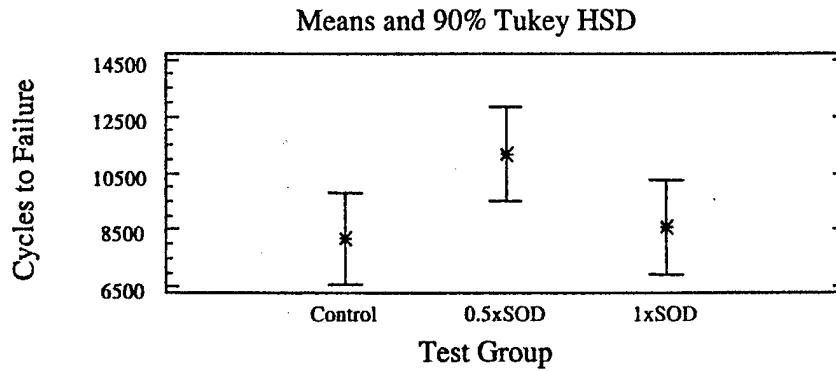

#### IV. SPOT WELD TENSILE-SHEAR STRENGTH TESTS

The spot weld tensile shear strength tests were performed under five different test groups: control (n=5), zero dwell at normal SOD (n=5), zero dwell at 0.5 normal SOD (n=5), zero dwell at 0.33normal SOD(n=5), and 2dwell at normal SOD(n=5). The one-factor analysis of variance indicated that there was no significant difference in the average tensile load at failure between the four test groups and the control group (p-value=0.1314). The graph below depicts the means and 90% intervals about the means for each test group.

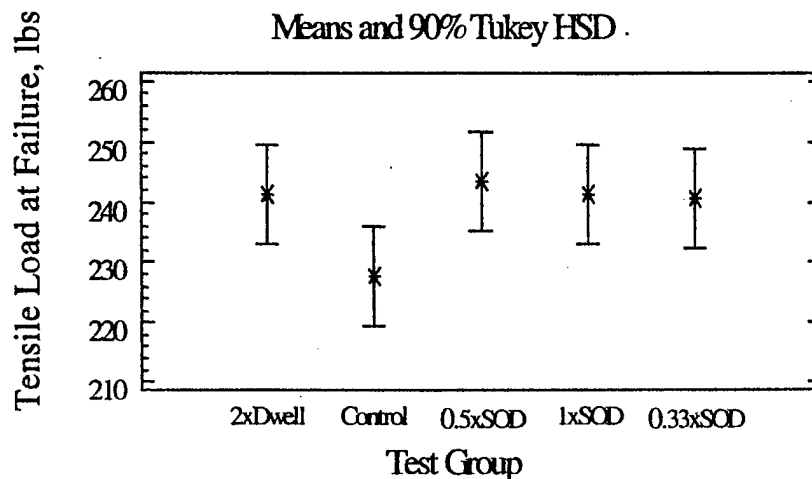

#### V. SPOT WELD TENSILE STRENGTH

The spot weld tensile strength tests were performed under five different test groups: control (n=5), zero dwell normal SOD (n=5), zero dwell 0.5 normal SOD (n=5), zero dwell .33normal SOD(n=4), and 2dwell normal SOD(n=5). The one-factor analysis of variance indicated that there was no

significant difference in the average tensile load at failure between the four test groups and the control group (p-value=0.7601). The graph below depicts the means and 90% intervals about the means for each test group.

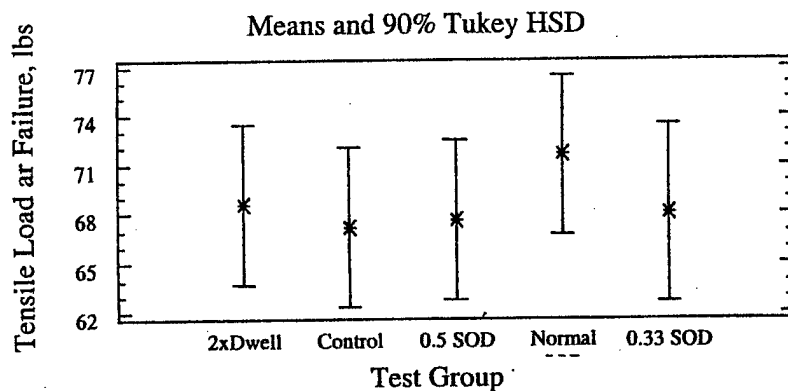

## **APPENDIX C**

**OO-ALC C-130 FLIGHT CONTROL and  
THIN SKIN (<.032) PLASTIC MEDIA BLAST PROCESS**

## C-130 FLIGHT CONTROL and THIN SKIN (<.032) PLASTIC MEDIA BLAST PROCESS

Reference Publications: 1-1-8, 1C-130A-23, 1-1-691, LAOOI 21-32

**PURPOSE.** The purpose of this process order is to establish local procedures to Plastic Media Blast (PMB) the coating system from C-130 flight controls and thin skins (<.032) and augment available technical data.

**SCOPE.** The requirements of this process order apply to all personnel engaged in PMB paint removal on C-130 flight control and thin skins in LAO, Buildings 220, 220 automated robot, and 206.

### GENERAL INFORMATION

#### 1. PROCESS

- a. This process order provides the details required ensuring that the C-130 flight controls and thin skin (<.032) substrates are properly prepped, blasted, and cleaned without damage.
- b. This process involves using 20-30 mesh size, Type V Plastic Media to depaint thin skins on the C-130 aircraft. The basic steps include masking/sealing all openings to prevent media intrusion, removing the paint with PMB, and removing prep material. Once this is complete, the surfaces are washed.
- c. Technicians performing this process will review referenced and applicable technical data before using the procedures in this process order. The technicians will also be familiar with the C-130 skin map, which designates the critical/ sensitive areas of the aircraft.
- d. Process Certification. Prior to blasting, the PMB process must be certified by a designated supervisor or wage leader. The following items must be verified and recorded on a local form (see attached form) for each set of flight controls or aircraft prior to blasting. Refer to T.O. 1-1-8, T.O. 1C-130A-23.
  - (1) Confirm sieve size (20-30).
  - (2) Confirm high density particle contamination (.02% max).
  - (3) With needle gage, check/set nozzle pressure (25 psi max.).
  - (4) With the custom made drum, check the media flow rate (480 lbs/hr).

- (5) With the Almen Arc Height fixture, Blast three (3) Almen strips using the required process parameters. Blast the Almen strips using the same procedures used to remove the coating system from the aircraft skins. Do not apply the blast stream for any longer time than what is needed to remove the adjacent coating system. Almen strips are to be blasted in a manner that the blast stream is applied across (against) the Almen strip roll direction (long axis of the Almen strip) at an angle of 90 degrees to the roll direction. When mounting the Almen strips in the holding fixture make sure that the unmarked (front) surface will be the blasted surface. Using the gage, check the difference heights before and after blasting (.006 inch max.).
- (6) Using the surface roughness gage, measure the roughness of the Almen test strips (170 max.).
- (7) Record all information on local form, including aircraft tail number, date, mechanic, supervisor, start time, and stop time.

**e. Process Parameters**

- |                        |  |
|------------------------|--|
| (1) Media              | Type V, 20-30 mesh   |
| (2) Blast angle        | 45 deg. To the plane of the structure  |
| (3) Nozzle pressure    | 25 psi   |
| (4) Media flow rate    | ~480 lbs/hr  |
| (5) Stand-off distance | 24 inches, measured from the tip of the blast nozzle to the surface of the structure |

- f. The LAOB, C-130 Engineering Office (Al Schliep/7-4458) will monitor/verify the use of pressure regulator locks during any blasting of C-130 thin skins on a weekly basis. This verification will be annotated in the "process verification sheet".
- g. Forms and record personnel will annotate in the aircraft historical data Form 95 that the aircraft was "Plastic Media Blasted with type V plastic media."

**2. SAFETY. The following are minimum requirements for personal safety:**

- a. All personnel performing the plastic media blast process shall be familiar with the pertinent safety practices and hazards contained in T.O. 1-1-8, T.O. 1-1-691, and other referenced material. Personnel will be trained on the operation of the equipment and the procedures on the aircraft. There must be a monitor of the process any time there is any blasting. The monitor is to observe the process for safety reasons as well as monitor the equipment.

- b. Blasters must wear required Personal Protective Equipment (PPE). At a minimum the required PPE includes the following:
- (1) Hearing protection
  - (2) Cloth coveralls
  - (3) Gloves
  - (4) High top leather shoes with vibram type sole
  - (5) Approved blast helmet with breathing air
  - (6) Safety harness if working higher than 7'
  - (7) Blast hoods will be stored in a clean, dust free area. Before leaving the blast area, the operator shall remove all dust possible from themselves and their hoods. All effort should be made to prevent dust from being carried into the lunch and break rooms as well as out of the building.

### **WARNING**

Airborne dust from the PMB process forms a potential hazard. All parts and assemblies being blasted, as well as blasting equipment, must be grounded to prevent build-up of static electricity. Personnel inside the blast booth during the PMB operation shall wear appropriate PPE as specified in this Process Order, other referenced technical data and by Bio-environmental Engineering (SGPB).

### **3. TRAINING**

Plastic Media Blasting requires extensive operator training and process controls in order to avoid damage to substrate materials. All PMB operators will be trained on the proper PMB procedures and specific C-130 thin skin parameters. The PMB operator must understand the mechanics and responsibilities of the PMB process. Training courses will be aircraft/task specific and an annual refresher course will be required of all operators. Training will be documented in personal training records. The robot operator is required to be certified in the operation of the robot and its associated systems by LAOE.

### **4. MONITOR**

The PMB process requires an equipment/process monitor be on site anytime a blasting operation is in progress. This person will monitor the equipment, process and ensure the blaster is in a safe environment.

## PROCEDURES

### Building 220 Automated Robot

1. Review applicable T.O.s, Job guides, flow-charts and process orders.
2. Position flight controls in booth.
3. Assess the aircraft/flight controls for any pre-existing damage. Inspect the surface and document any surface problems.
4. Prior to applying tape, glue and other prep materials, always clean surface with approved cleaner.
5. Glue aluminum protective end covers in place.
6. Cover all drain holes and openings with blast tape and glue edges with hot glue.
7. Place pre-made covers over large openings and sensitive areas.
8. Inspect to ensure all openings have been covered.
9. Position flight control in place and raise with the overhead hoist. Place in tooling fixture to secure in place while blasting.
10. Start blast booth. Refer to operation instructions in LAOOI 21-32, Plastic Media Blast Equipment Operation.
11. Prepare robot for stripping.
12. Calibrate the blast equipment and perform the process verification/certification as stated in "Process Parameters" and "Process Certification" and document in forms. Physically verify the 24" stand-off distance.
13. Position robot to pre-determined reference points.
14. Blast surfaces using parameters outlined in the "Process Parameters" section of this process order.

**CAUTION**

Keep blast nozzle moving at all times. Do not allow robot to dwell on one spot as damage may result.

Be careful when blasting around skin seams. Do not blast directly on them or lifting could result.

If you encounter any irregularities or uncover any damage while blasting, STOP IMMEDIATELY. If in doubt, STOP! Notify wage leader or supervisor for disposition.

15. Inspect flight controls after blasting is complete to see if all the paint has been removed and to make sure no damage has occurred.
16. Turn off system following procedures outlined in LAOOI 21-32, Plastic Media Blast Equipment Operation. Clean area.
17. Place flight controls in a transportation dolly and move into wash/de-prep area.
18. Remove masking, glue, and other prep materials.
19. Clean and wash. Rinse or flush surface inside and out. Ensure residual media has been removed.
20. Tag and route flight controls when finished.
21. Turn in all documents to the scheduler.
22. Place PMB certification/data sheet into designated folder on supervisor's desk.

**Building 220 Manual**

1. Review applicable T.O.s, job guides, flow-charts and process orders.
2. Position Flight controls in booth.
3. Assess the aircraft/flight controls for any pre-existing damage. Inspect the surface and document any surface problems.

4. Prior to applying tape, glue, and other prep materials, always clean surface with approved cleaner.
5. Glue aluminum protective end covers in place.
6. Cover all drain holes and openings with blast tape and glue edges with hot glue.
7. Place pre-made covers over large openings and sensitive areas.
8. Inspect to ensure all openings have been covered.
9. Place flight control in blasting rack/dolly/A-frame, etc.
10. Install standoff distance shop-aid on the blast nozzle and set to 24".
11. Start blast booth. Refer to operation instructions in LAOOI 21-32, Plastic Media Blast Equipment Operation.
12. Calibrate blast equipment and perform the process verification/certification as stated in "Process Parameters" and "Process Certification" and document in forms.
13. Install the master pressure regulator gauge lock on the master pressure regulator gauge. Ensure it is set at no more that 25-psi at the nozzle. **DO NOT REMOVE LOCK UNTIL FLIGHT CONTROLS ARE COMPLETED.**
14. Blast surfaces using parameters outlined in the "Process Parameters" section of this process order.

**CAUTION**

Keep blast nozzle moving at all times. Do not dwell on one spot as damage may result.

Be careful when blasting around skin seams. Do not blast directly on them or lifting could result.

If you encounter any irregularities or uncover any damage while blasting, **STOP IMMEDIATELY.** If in doubt, **STOP!** Notify wage leader or supervisor for disposition.

15. Inspect flight controls after blasting is complete to see if all the paint has been removed and to make sure no damage has occurred.

16. Turn off system following procedures outlined in LAOOI 21-32, Plastic Media Blast Equipment Operation. Clean area.
17. Place flight controls in a transportation dolly and move into wash/de-prep area.
18. Remove masking, glue, and other prep materials.
19. Clean and wash. Rinse or flush surface inside and out. Ensure residual media has been removed.
20. Tag and route flight controls when finished.
21. Turn in all documents to the scheduler.
22. Place PMB certification/data sheet into designated folder on supervisor's desk.

#### **Building 206 Aircraft Thin Skin Stripping**

1. Review applicable T.O.s, job guides, flow-charts, and process orders.
2. Assess the aircraft skins for any pre-existing damage. Inspect the surface and document any surface problems.
3. Prepare aircraft as stated in P.O. for PMB of C-130 aircraft, identifying and marking thin skin areas.
4. Prior to applying tape, glue, always clean surface with approved cleaner.
5. Cover all drain holes and openings with blast tape and cover edges with hot glue.
6. Place pre-made covers over large openings.
7. Inspect to ensure all openings have been covered.
8. Start blast booth. Refer to operation instructions in LAOOI for Plastic Media Blast Equipment Operation in Building 206.
9. Calibrate specific blast equipment and perform the process certification as stated in "Process Parameters" and "Process Certification" and document in forms.
10. Install the master pressure regulator gauge lock on the master pressure regulator gauge. Ensure it is set no more than 25-psi at the nozzle. **DO NOT REMOVE LOCK UNTIL THIN SKINS HAVE BEEN STRIPPED.**

11. Thin skins will be blasted first. Blast surfaces using parameters outlined in the "Process Parameters" section of this process order. Install standoff distance fixture on nozzle end and set to 24".

**CAUTION**

Keep blast nozzle moving at all times. Do not dwell on one spot as damage may result.

Be careful when blasting around skin seams. Do not blast directly on them or lifting could result.

If you encounter any irregularities or uncover any damage while blasting, STOP IMMEDIATELY. If in doubt, STOP! Notify wage leader or supervisor for disposition.

12. Inspect surfaces after blasting is complete to see if all the paint has been removed and to make sure no damage has occurred.
13. Blast the rest of the aircraft In accordance with C-130 P.O.
14. De-prep aircraft as stated in C-130 P.O.
15. Clean and wash aircraft. Ensure residual media has been removed.
16. Turn in all documents to the scheduler.
17. Place PMB certification/data sheet into designated folder on supervisor's desk

4/5/99

### PLASTIC MEDIA BLAST CERTIFICATION AND DATA SHEET

Date \_\_\_\_\_ Process Start Time \_\_\_\_\_ Process Complete Time \_\_\_\_\_

Mechanic Name \_\_\_\_\_

Supervisor \_\_\_\_\_

Aircraft Tail Number \_\_\_\_\_

	Pass	Fail
Media Sieve Size	<input type="checkbox"/>	<input type="checkbox"/>

Media high density contamination (<.02%)	<input type="checkbox"/>	<input type="checkbox"/>
--	--------------------------	--------------------------

Blast Nozzle Pressure (25 psi max) \_\_\_\_\_ psi

Media Flow Rate (~480 lbs/hr) \_\_\_\_\_ lbs/hr

Almen Arc Height (.006 max.) #1 \_\_\_\_\_ #2 \_\_\_\_\_ #3 \_\_\_\_\_

Surface Roughness (170 max) \_\_\_\_\_ RMS

Stand-off Distance (24") \_\_\_\_\_ inches

Blast Angle (45 deg.) \_\_\_\_\_ deg.

#### INCOMING DAMAGE ASSESMENT

	Yes	No
Damage	<input type="checkbox"/>	<input type="checkbox"/>

#### COMMENTS

\_\_\_\_\_

\_\_\_\_\_

\_\_\_\_\_

Certifying Supervisor Signature \_\_\_\_\_  
NOTE: Turn in for supervisor's records