

74128

NASA TECHNICAL NOTE

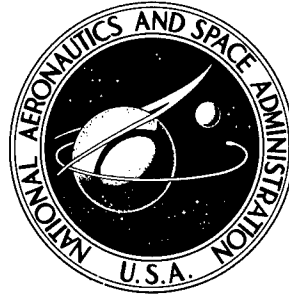

NASA TN D-5097

NASA TN D-5097

AMPTIAC

DISTRIBUTION STATEMENT A
Approved for Public Release
Distribution Unlimited

PRELIMINARY INVESTIGATION OF GRAPHITE FLUORIDE $(CF_x)_n$ AS A SOLID LUBRICANT

by Robert L. Fusaro and Harold E. Sliney

*Lewis Research Center
Cleveland, Ohio*

DTIC QUALITY INSPECTED 4
20000908 213

NASA TN D-5097

PRELIMINARY INVESTIGATION OF GRAPHITE FLUORIDE $(CF_x)_n$
AS A SOLID LUBRICANT

By Robert L. Fusaro and Harold E. Sliney

Lewis Research Center
Cleveland, Ohio

NATIONAL AERONAUTICS AND SPACE ADMINISTRATION

For sale by the Clearinghouse for Federal Scientific and Technical Information
Springfield, Virginia 22151 - CFSTI price \$3.00

ABSTRACT

Friction and wear life studies were conducted on burnished (rubbed on) films of a potential, new, solid lubricant $(CF_x)_n$. Results were compared with those of similar tests for graphite and MoS_2 . The comparisons showed that, at any one specific temperature, the wear lives of $(CF_x)_n$ films exceeded those of graphite or MoS_2 . Also, the friction coefficient of $(CF_x)_n$ was less than that of graphite and approximately equal to that of MoS_2 . The upper temperature limitation of the $(CF_x)_n$ burnished films is about $400^\circ C$. The influence of the fluorine-to-carbon ratio in the compound was investigated and did not seem to be of importance in the range considered (1.12 to 0.7).

PRELIMINARY INVESTIGATION OF GRAPHITE FLUORIDE $(CF_x)_n$ AS A SOLID LUBRICANT

by Robert L. Fusaro and Harold E. Sliney

Lewis Research Center

SUMMARY

A preliminary investigation of graphite fluoride $(CF_x)_n$ as a potential, new, solid lubricant was conducted. The $(CF_x)_n$ powders were burnished (rubbed) onto roughened stainless-steel disks and were evaluated in a pin-on-disk sliding-friction apparatus. For comparison, similar tests were conducted using burnished films of graphite or molybdenum disulfide (MoS_2).

The results indicated that graphite fluoride will lubricate in moist air, dry air, or dry argon to a temperature of about $400^{\circ}C$. The friction coefficient varies with temperature and the type of stainless-steel disk used and ranges from 0.02 to 0.15. This friction coefficient is less than that for graphite (minimum value, 0.09) and is about equal to that for MoS_2 . Also, disks that were lubricated with graphite fluoride showed a longer wear life than disks lubricated with either graphite or MoS_2 .

The fluorine-to-carbon ratio may be altered by varying the reaction temperature during the preparation of $(CF_x)_n$. Tests were conducted using $(CF_x)_n$ powders with the following fluorine-to-carbon ratios: 1.12, 0.99, 0.90, and approximately 0.7. No discernible differences in wear life or friction coefficient could be detected in these compounds.

INTRODUCTION

Choosing a candidate for a new, solid lubricant necessitates that certain basic requirements be met, some of which are reviewed in reference 1. The authors list thermal stability, low shear strength, surface protection, surface adherence, and a lamellar structure as desirable properties of a good solid lubricant. These properties are explored in more depth in reference 2.

Graphite fluoride ($CF_x)_n$ is a material that seems to possess the aforementioned qualities. This fact was recognized by Petronio and his associates of the Frankford Arsenal, who suggested its potential as a solid lubricant. Thus, the objective of the present investigation, conducted at the NASA Lewis Research Center, was to make a preliminary study of the friction and wear properties of the compound. The graphite fluoride powder was burnished (rubbed) onto roughened 440-C or 301 stainless-steel disks that were in sliding contact with 440-C stainless-steel riders in a high-temperature pin-on-disk friction apparatus. The friction coefficients and wear lives of the rubbed films were determined over a temperature range of 25° to 480° C. For comparison, similar tests were conducted with graphite and MoS_2 .

Four different types of ($CF_x)_n$ powders were available for evaluation. The fluorine-to-carbon ratios of the compounds tested were 1.12, 0.99, 0.90, and approximately 0.7. Frankford Arsenal supplied the ($CF_x)_n$ powders, which were made at Rice University.

GRAPHITE FLUORIDE BACKGROUND

For over a century, graphite has been known to form compounds by the inclusion of foreign atoms within its structure (ref. 3). In 1934, Ruff and Bretschneider (ref. 4) discovered that graphite and fluorine combined without combustion at about 420° C to form a grey-colored solid. The approximate composition of this solid was ($CF_x)_n$, where x is nearly equal to 1. They called the compound carbon monofluoride and found that it was hydrophobic and had a high electrical resistance. X-ray diffraction studies indicated that the distance between the carbon-layer planes had been expanded from 3.4 Å in graphite to about 8 Å in graphite fluoride.

Since 1934, other experimenters (refs. 5 to 10) have studied the compound and obtained similar results. Reference 7 reported that the reaction of formation could take place in the temperature range of 420° to 550° C. Varying this temperature resulted in different fluorine-to-carbon ratios in the compound. The compounds with the highest proportion of fluorine were nearly white in color and almost nonconducting.

The structure of ($CF_x)_n$ has not been definitely determined, but a structure consisting of covalent bonds between the fluorine and carbon atoms and a tetrahedral arrangement of the carbon bonds has been proposed (ref. 8). Another proposal is that the true hexagonal structure of the carbon atoms has been distorted; not only has the distance between the carbon-layer planes been expanded, but the carbon-to-carbon distance within the layer has also been stretched. The structure thus consists of a "wavy layer" of carbon atoms interposed between two layers of fluorine atoms. This type of structure implies a loss of the aromatic character of the carbon-layer planes, which is consistent with the color changes and the electrical resistance of graphite fluoride. The structure of the carbon-

layer planes of graphite is schematically illustrated in figure 1(a). Figure 1(b) shows the same planes after the graphite was reacted with fluorine to form graphite fluoride. A comparison of some of the physical properties of $(CF_x)_n$ obtained by various experimenters is given in table I (ref. 11), along with some corresponding data on graphite (ref. 12).

The reaction rate of fluorine with graphite at various partial pressures and temperatures was investigated by Kuriakose and Margrave (ref. 13), who found that, at all temperatures up to 900°C , the reaction rate depended on the fluorine partial pressure. The first detectable reaction occurred at 315°C at a fluorine partial pressure of 13.2 torr. The same authors (ref. 14) also conducted mass spectrometric studies on the thermal decomposition of $(CF_x)_n$ under a high vacuum to 580°C . When the compound was heated, decomposition did not commence until 420°C . At this temperature, elemental carbon and fluorocarbons that contained up to six carbon atoms were produced.

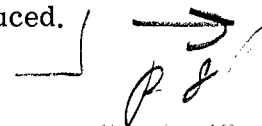

FRICION APPARATUS

A diagram of the high-temperature friction apparatus used in this investigation is shown in figure 2. The riders were hemispherically tipped with a radius of 0.476 centimeter. The riders were loaded with dead weights against a flat 6.3-centimeter-diameter disk that was rotated at 600 rpm. This rotation gave the rider a linear sliding speed of 1.6 meters per second relative to a 5-centimeter-diameter circular track on the disk. The normal load applied to the riders was 500 grams.

The disks were heated by a high-frequency induction unit. The temperature was monitored by a thermocouple when the disk was not rotating and by an infrared optical pyrometer when it was in motion. A strain gage was used to measure the frictional force, which was continuously recorded on a strip-chart recorder.

EXPERIMENTAL PROCEDURE

Disk Surface Preparation and Cleaning Procedure

Both 440-C and 301 stainless-steel disks were used in the experiments. The 440-C disks had a Rockwell C hardness of 60, and the softer 301 disks had a Rockwell B hardness of 87. The surfaces were roughened to an rms finish of 0.90 to 1.25 micrometers (35 to 50 $\mu\text{in.}$). A sandblasting device was used to roughen the 440-C stainless-steel disk, and a glass-peening device was used to roughen the 301 stainless-steel disk. The reason for using two different roughening devices was to keep the roughness of the softer

301 stainless-steel disk close to that of the 440-C disk. Surface profiles of the two disks are shown in figure 3.

After the surfaces were roughened, they were scrubbed with a brush under running water to ensure that no abrasive particles remained. The disks were then rinsed with distilled water and stored in a desiccator. The riders were cleaned by scrubbing them with toluene and then ethyl alcohol. A water paste of levigated alumina, used as a final cleanser, was applied with a clean, white polishing cloth. Cleaning continued until no trace of sediment from the rider could be seen on the cloth. The riders were then rinsed in distilled water and also stored in the desiccator.

Coating Procedure

The back of a napped polishing cloth was used to burnish the lubricant powders onto the dried, roughened disk surface. The back of the polishing cloth was used because it was made with an open weave (twilled) and therefore served as a good applicator. Because this method of application provides a very thin coating, only a very small amount of $(CF_x)_n$ was needed to burnish the disk. The thinness of these films is illustrated in figure 4, which shows a disk before and after it was burnished. The metal surface is clearly visible through the $(CF_x)_n$ film.

Powder Description

Photomicrographs of the MoS_2 , $(CF_{1.12})_n$, and graphite powders used in this study are shown in figure 5. The average particle size (manufacturer's value) for the MoS_2 powder is 0.7 micrometer and for the graphite powder is 0.5 micrometer. The particle size of the $(CF_{1.12})_n$ powder is unknown. The photomicrographs do not necessarily represent the average particle sizes because the powders tend to agglomerate. The type of graphite used was natural flake Madagascar graphite.

Test Conditions

After the lubricant was burnished onto the disk, both the disk and the rider were placed in the friction apparatus (fig. 2). The test chamber was either left open for the moist-air experiments (moisture content, 10 000 ppm) or was sealed for the dry-atmosphere experiments (moisture content of dry air and dry argon, 20 ppm). A 1-hour purge was begun prior to the friction experiments at a flow rate of 800 cubic centimeters

per minute, and a positive pressure of 7×10^3 newtons per square meter (1 psi) was maintained in the chamber, which had a volume of 2000 cubic centimeters.

After the purge was completed, the temperature of the disk was slowly raised to the desired temperature by induction heating. This temperature was then held for 15 minutes to ensure that the disk was uniformly heated. The disk was then set into rotation at 600 rpm and the load applied.

The criterion used for failure was that point at which the friction coefficient of the lubricated disk approaches the value of an unlubricated disk. Some preliminary experiments were conducted to determine the friction characteristics of the unlubricated metal disks in the various atmospheres used.

DISCUSSION OF RESULTS

Experiments in Dry Air

Experiments with graphite fluoride powders were conducted on roughened 440-C stainless-steel disks and riders. These disks were run in dry air (moisture content, 20 ppm) at a speed of 1.6 meters per second with a load of 500 grams. For comparison, similar tests were conducted on MoS_2 . The results of both these tests are shown in figure 6, where minimum mean friction coefficients and wear lives are plotted against temperature. Also illustrated is a band that represents the coefficient of friction for the unlubricated metal combination.

In most of the cases tested (for both powders), there was a run-in period of about 1 minute. During this time, the friction coefficient rises to a value of 0.10 or higher. It then drops to a minimum value and remains constant for a short period of time. The values of the friction coefficient presented in this report are these minimum values. The authors consider these values the most representative of the solid lubricant friction coefficient because, after a short period of time, some metal-to-metal contact occurs through asperities. Thus, the friction coefficient becomes a combination of metal and solid lubricant coefficients. As more and more metal is exposed, the friction increases gradually until the value for the unlubricated metal is reached.

At 400°C for MoS_2 and at 480°C for $(\text{CF}_{1.12})_n$, no constant minimum value for the friction coefficient was observed. The friction rose very sharply, as shown by the arrows in figure 6. Graphite fluoride starts to decompose at 420°C (as mentioned previously, ref. 14); this behavior is the most likely reason for the increase in the friction coefficient and the reduction in the wear life of the film at this temperature.

The friction coefficients for $(\text{CF}_{1.12})_n$ films are slightly higher (0.03 to 0.15) than those for the MoS_2 films (0.02) over the temperature range 25° to 250°C . The wear lives of the $(\text{CF}_{1.12})_n$ films, however, are more than 6 times as great. For example,

at room temperature, the average wear life of a $(CF_{1.12})_n$ film was 450 minutes, whereas that of a MoS_2 film was only 70 minutes. Another observation was that the wear lives of both films seemed to decrease exponentially with increased temperature.

Similar experiments were also conducted on 301 stainless-steel disks and 440-C stainless-steel riders. The 301 disks were finished to approximately the same surface roughness as the 440-C disks (fig. 3) but were not as hard (Rockwell B 87) as the 440-C disks (Rockwell C 60).

The results of the 301 disk tests are shown in figure 7, where the friction coefficient and wear life are plotted against temperature. Under the same test conditions as those used for the 440-C disks, neither MoS_2 nor graphite would provide continued lubrication for this particular metal combination. Graphite fluoride powder, however, lubricated very well under the same conditions. The results obtained showed that the wear life of the $(CF_x)_n$ film on the soft 301 stainless-steel disk had been reduced. For example, the life at $25^\circ C$ is 250 minutes compared with 450 minutes for the 440-C disk. From 25° to $260^\circ C$, the friction coefficient was also lower, ranging from 0.015 to 0.03 for the 301 disk compared with 0.03 to 0.15 for the 440-C disks.

The variation of the friction coefficient in dry air with time at 25° and $400^\circ C$ is shown in figures 8(a) and (b), respectively. Data are plotted for $(CF_{1.12})_n$ and MoS_2 burnished films on disks of 440-C and 301 stainless steel and for graphite burnished films and disks of 301 stainless steel. At $25^\circ C$, neither MoS_2 nor graphite would lubricate the 301 stainless-steel disks. However, MoS_2 effectively lubricated 440-C steel for 70 minutes at 25° but for less than 1 minute at $400^\circ C$. The $(CF_{1.12})_n$ lubricated both 301 and 440-C stainless steel for longer than 320 minutes at $25^\circ C$. At $400^\circ C$, $(CF_{1.12})_n$ was the only burnished film of the three that would provide lubrication.

Experiments in Dry Argon

Tests were also conducted in dry argon (moisture content, 20 ppm) on 301 disks and 440-C riders. The rest of the experimental parameters were unchanged. The results of these experiments are presented in figure 9, which shows that the friction coefficient of $(CF_{1.12})_n$ is about the same (0.02 to 0.04) as those for films tested on 301 disks in dry air. Wear life, however, decreased to 50 minutes compared with 250 minutes in dry air at $25^\circ C$. The wear life values at the various temperatures are somewhat more scattered than those obtained in the dry-air runs, but they still seemed to decrease exponentially with increasing temperature. Graphite and MoS_2 were also tested in a dry argon atmosphere, but they would not lubricate the 301 stainless-steel disks.

Experiments in Moist Air

Graphite is known to lubricate better in moist air than in dry-air environments (ref. 15). Selected tests were therefore run at 25° C in moist room air (moisture content, 10 000 ppm) to compare the lubricating ability of graphite and MoS₂ with that of graphite fluoride in a moist atmosphere. The results are presented in table II, where data taken with both metal combinations in all three atmospheres are compared. On 301 stainless-steel disks in moist air, (CF_{1.12})_n has a lower friction coefficient (0.05) than graphite (0.09). The wear life of (CF_{1.12})_n is also longer (>700 min) than that of graphite (350 min).

A few tests were also made with (CF_{1.12})_n and MoS₂ burnished onto 440-C stainless-steel disks. The friction coefficient of (CF_{1.12})_n was 0.06 whereas that of MoS₂ was 0.15. The wear life of (CF_{1.12})_n was 1200 minutes compared with 30 minutes for MoS₂.

Effect of Fluorine-to-Carbon Ratio

Some experiments were performed in dry argon to determine whether or not the fluorine-to-carbon ratio influenced the frictional properties of the compound. Four different (CF_x)_n compounds with the following fluorine-to-carbon ratios were tested: 1.12, 0.99, 0.90, and a value of about 0.7. Tests were conducted at 25° and 400° C on 440-C stainless-steel riders against 301 stainless-steel disks. The linear velocity was 1.6 meters per second and the load was 500 grams. No appreciable difference in the friction coefficients or in the wear lines of the various compounds could be detected. The wear lives of the (CF_x)_n films are compared in figure 10. Graphite, also shown in the figure for comparison, failed immediately under the same conditions. Other than for this comparison, CF_{1.12} powder was the only (CF_x)_n powder used in this program to ensure consistency.

SUMMARY OF RESULTS

An experimental program was conducted to investigate the lubricating ability of a potential, new, solid lubricant, graphite fluoride ((CF_x)_n). Tests were run in dry air (moisture content, 20 ppm), dry argon (moisture content, 20 ppm), and moist air (moisture content, 10 000 ppm) on roughened 440-C and 301 stainless-steel disks burnished with (CF_x)_n powder. The results were compared with those obtained in similar tests conducted on molybdenum disulfide (MoS₂) and graphite powders. The following major results were obtained:

1. In all atmospheres tested, the friction coefficients of $(CF_x)_n$ were comparable or superior to those of MoS_2 and of graphite.

2. The wear lives of $(CF_x)_n$ films at any particular temperature was always greater than those of MoS_2 or of graphite; the difference (in wear life) was sometimes greater by a factor of 6.

3. A moist atmosphere seemed to increase the wear lives of the $(CF_x)_n$ films, but it also increased the friction coefficients.

4. The fluorine-to-carbon ratio did not seem to affect the frictional properties of $(CF_x)_n$ films in the range of $(CF_{0.7})_n$ to $(CF_{1.12})_n$.

Lewis Research Center,
National Aeronautics and Space Administration,
Cleveland, Ohio, December 23, 1968,
126-15-02-27-22.

REFERENCES

1. Peterson, M. B.; Murray, S. F.; and Florek, J. J.: Consideration of Lubricants for Temperatures Above 1000° F. ASLE Trans., vol. 2, no. 2, May 1960, pp. 225-234.
2. Bisson, Edmond E.; and Anderson, William J.: Advanced Bearing Technology. NASA SP-38, 1964.
3. Croft, R. C.: Lamellar Compounds of Graphite. Quarterly Rev. (London), vol. 14, no. 1, 1960, pp. 1-45.
4. Ruff, Otto; Bretschneider, Otto; and Ebert, Fritz: The Reaction Products of Various Forms of Carbon with Fluorine. II. Carbon Monofluoride. Z. anorg. allgem. Chem., vol. 217, 1934, pp. 1-19.
5. Hoffmann, U.: Graphite and Graphite Compounds. Ergeb. Exakt. Naturw., vol. 18, 1939, pp. 229-256.
6. Bigelow, Lucius A.: The Action of Elementary Fluorine Upon Organic Compounds. Chem. Rev., vol. 40, 1947, pp. 51-115.
7. Rüdorff, Walter; and Rüdorff, Gerda: The Catalytic Influence of Hydrofluoric Acid on the Formation of Carbon Monofluoride. Chem. Ber., vol. 80, 1947, pp. 413-417.
8. Rüdorff, Walter; and Rüdorff, Gerda: Structure of Carbon Monofluoride. Z. Anorg. Chem. vol. 253, 1947, pp. 281-296.

9. Palin, D. E.; and Wadsworth, K. D.: Structure of Carbon Monofluoride. Nature, vol. 162, 1948, pp. 925-926.
10. Watanabe, Nobuatsu; Koyama, Yoshiyuki; and Yoshizawa, Shiro: Studies on the Preparation of Fluorine and Its Compounds. VIII. The Formation Reaction of Graphite Fluoride. J. Electrochem. Soc. Japan, vol. 32, no. 1, 1964, pp. 17-25.
11. Anon.: Tetracarbonmonofluoride. Structure Reports, Leipzig: Utrecht, II, 1947-1948, pp. 212-217.
12. Stock, Arthur J.: Graphite, Molybdenum Disulfide and PTFE - A Comparison. Lubr. Eng., vol. 19, no. 8, Aug. 1963, pp. 333-338.
13. Kuriakose, A. K.; and Margrave, J. L.: Kinetics of the Reactions of Elemental Fluorine. IV. Fluorination of Graphite. J. Phys. Chem., vol. 69, no. 8, Aug. 1965, pp. 2772-2775.
14. Kuriakose, A. K.; and Margrave, J. L.: Mass Spectrometric Studies of the Thermal Decomposition of Poly (carbon monofluoride). Inorg. chem., vol. 4, no. 11, Nov. 1965, pp. 1639-1641. *end*
15. Savage, Robert H.: Physically and Chemically Adsorbed Films in the Lubrication of Graphite Sliding Contacts. Ann. N. Y. Acad., Sc. vol. 53, 1951, pp. 862-869.

TABLE I. - COMPARISON OF SOME OF PHYSICAL PROPERTIES
OF GRAPHITE FLUORIDE AND GRAPHITE

Powder	Density, g/cu cm	Carbon-to- carbon in- layer distance, Å	Distance be- tween carbon- layer planes, Å	Electrical resistance ohm-cm	Reference
(CF _{1.085}) _n	≥2.39	1.42	8.2	>3×10 ³	4
(CF _{0.988}) _n	2.67	1.54	6.6	>3×10 ³	7
(CF _{0.996}) _n	2.78	1.49	6.0	>3×10 ³	8
Graphite	1.4 to 1.7	1.42	3.35	5×10 ⁻³	11

TABLE II. - COMPARISON OF FRICTION COEFFICIENT AND WEAR LIFE
OF BURNISHED FILMS OF GRAPHITE FLUORIDE, GRAPHITE,
AND MOLYBDENUM DISULFIDE IN THREE DIFFERENT
ATMOSPHERES AT 25° C

[Moisture content: moist air, 10 000 ppm; dry air, 20 ppm; dry argon, 20 ppm; linear sliding speed, 1.6 m/sec; load, 500 g; riders, 440-C stainless steel.]

Powder	Disk substrate (stainless steel)	Minimum friction coefficient			Wear life, min		
		Atmosphere					
		Moist air	Dry air	Dry argon	Moist air	Dry air	Dry argon
(CF _{1.12}) _n Graphite	301	0.05	0.02	0.025	700+	250	50
	301	.09	Immediate failure ^a	Immediate failure	350	0	0
MoS ₂	301	----	Immediate failure	Immediate failure	---	0	0
(CF _{1.12}) _n MoS ₂	440-C	.06	.15	-----	1200	450	--
	440-C	.15	.02	-----	30	70	--

^aCriterion for failure was a frictional force equal to that of unlubricated metal combination.

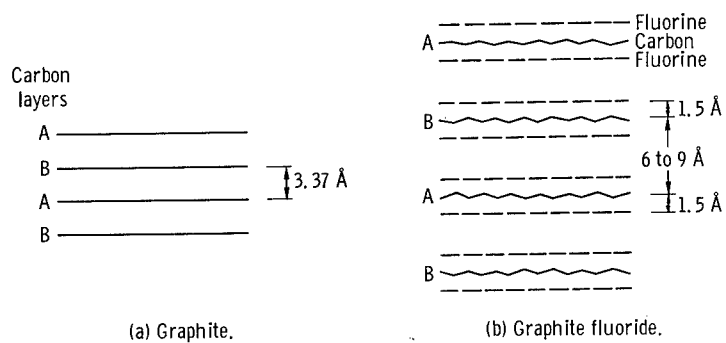

Figure 1. - Structure of graphite and proposed structure of graphite fluoride illustrating expansion of carbon-layer planes due to intercalation of fluorine atoms between them. (Note waviness of carbon planes in graphite fluoride.)

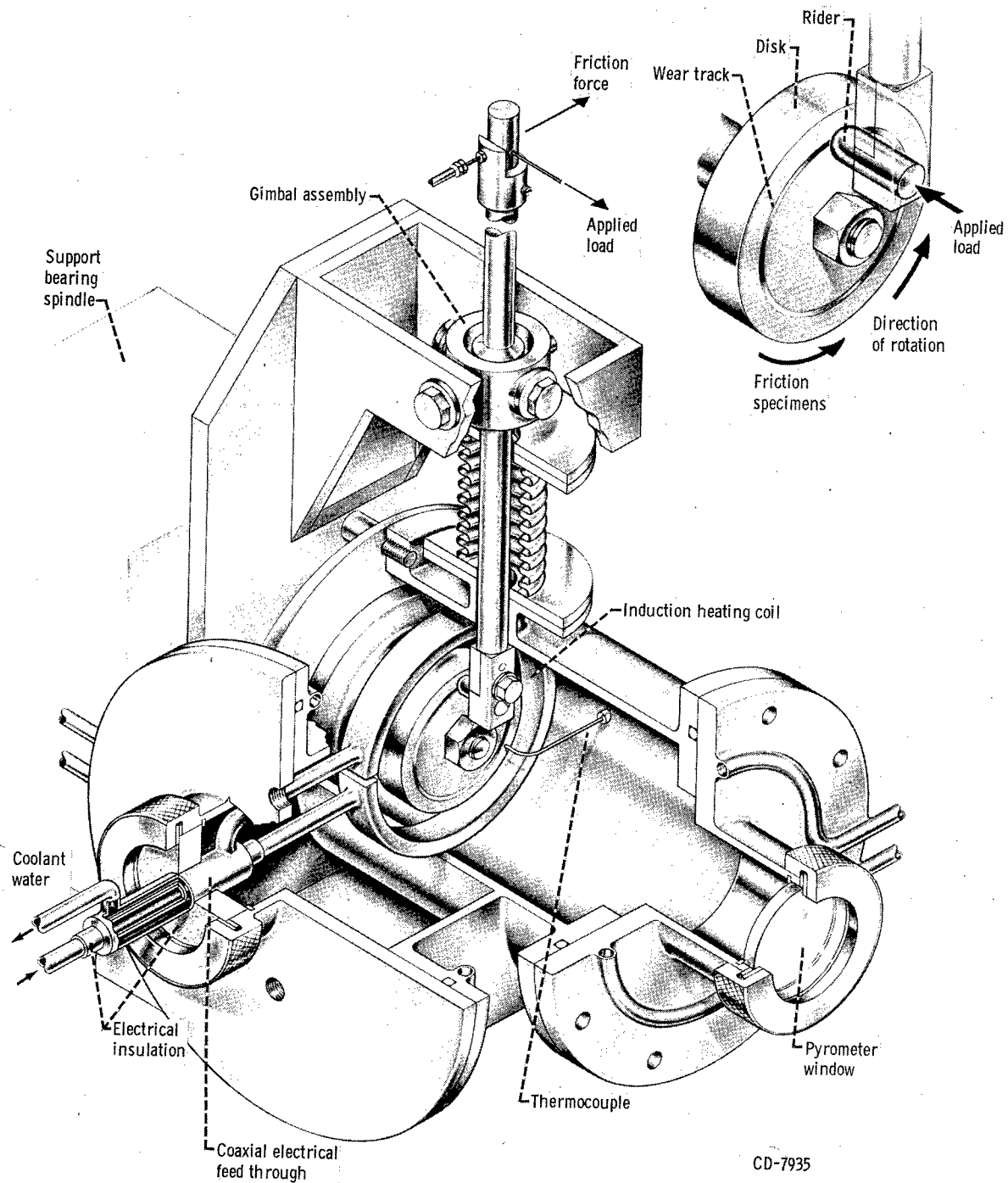
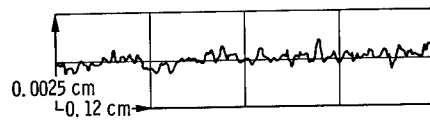
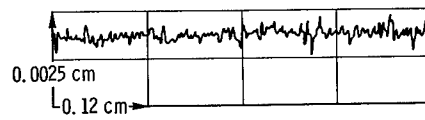

Figure 2. - High-temperature friction apparatus.



(a) Glass-peened 301 stainless-steel disk.



(b) Sand-blasted 440-C stainless-steel disk.

Figure 3. - Surface profiles of 301 and 440-C stainless-steel disks after roughening. Range of surface roughness varies from 0.90 to 1.25 micrometers (35 to 50 μ in.) rms.



(a) Disk before burnishing.

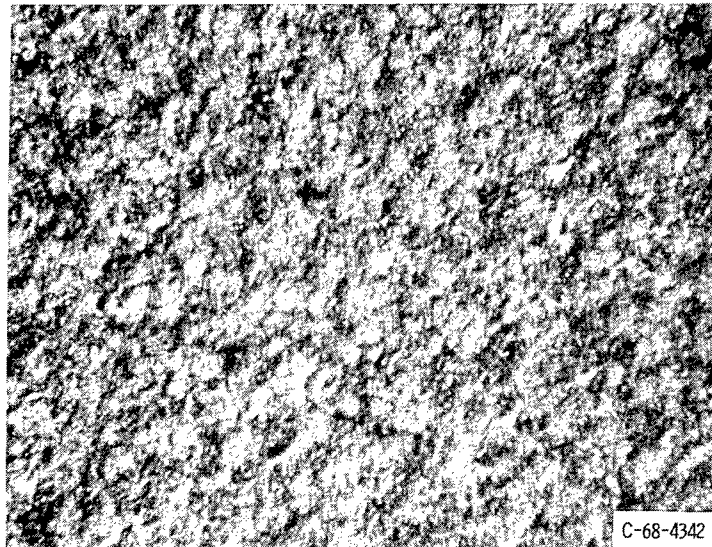

(b) Disk burnished with graphite fluoride ((CF_{1.12})_n) powder.

Figure 4. - Comparison of glass-peened 301 stainless-steel disk before and after burnishing with graphite fluoride. Range of surface roughness varies from 0.90 to 1.25 micrometers (35 to 50 μ n.) rms.

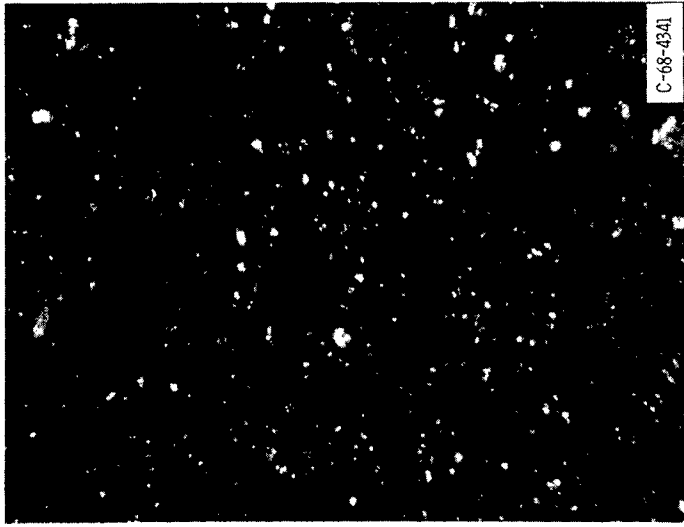

Graphite

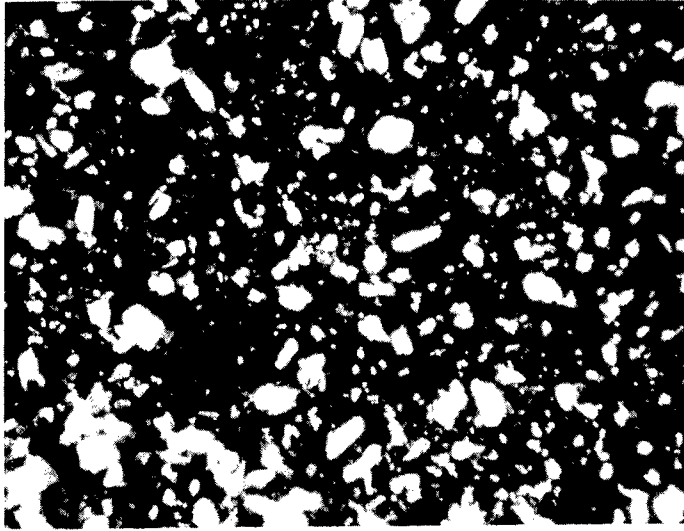

Graphite fluoride

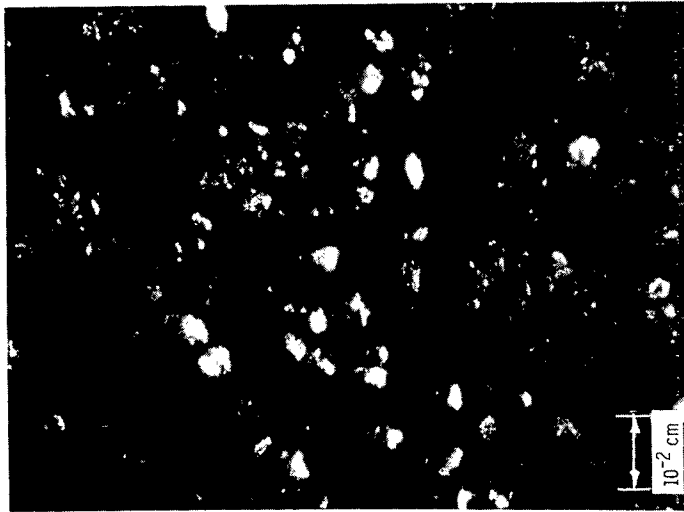

Molybdenum disulfide

Figure 5. - Comparison of molybdenum disulfide, graphite fluoride ($(CF_{1.12})_n$), and graphite powders used in present investigation. Known average particle sizes of molybdenum disulfide and graphite are 0.7 and 0.5 micrometer (28 and 20 μ in.), respectively. (Both reflected and transmitted light were used.)

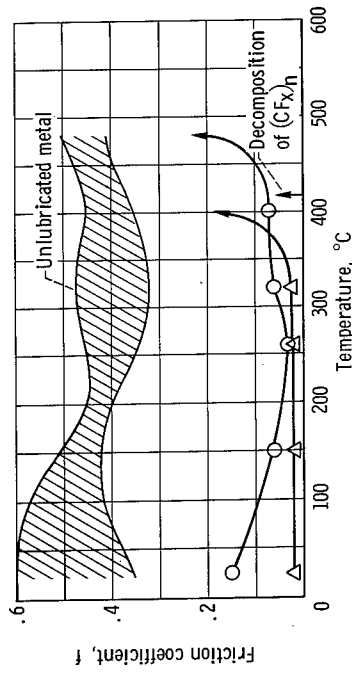
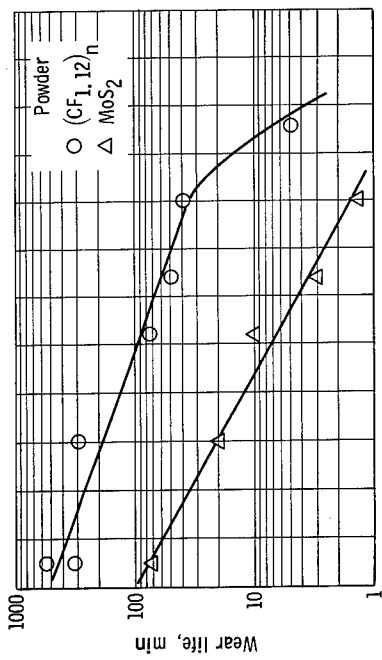

Figure 6. - Effect of temperature on wear life and friction coefficient of graphite fluoride $(CF_{1.12})_n$ and molybdenum disulfide powders burnished on sand-blasted 440-C stainless-steel disks. Riders, 440-C stainless steel; linear sliding speed, 1.6 meters per second; load, 500 grams; atmosphere, dry air (moisture content, 20 ppm).

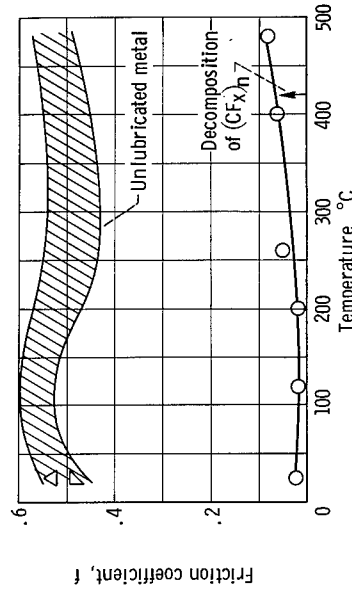
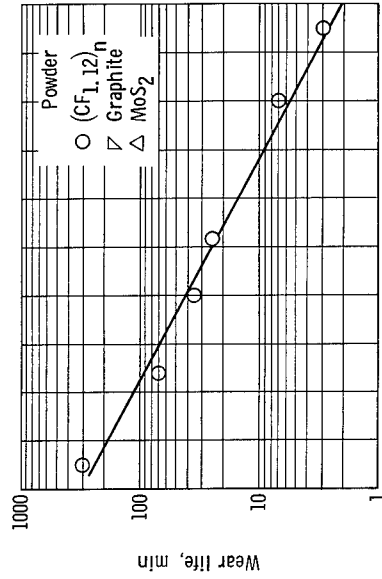

Figure 7. - Effect of temperature on wear life and friction coefficient of graphite fluoride $(CF_{1.12})_n$, graphite, and molybdenum disulfide powders burnished on glass-peened 301 stainless-steel disks. Riders, 440-C stainless steel; linear sliding speed, 1.6 meters per second; load, 500 grams; atmosphere dry air (moisture content, 20 ppm).

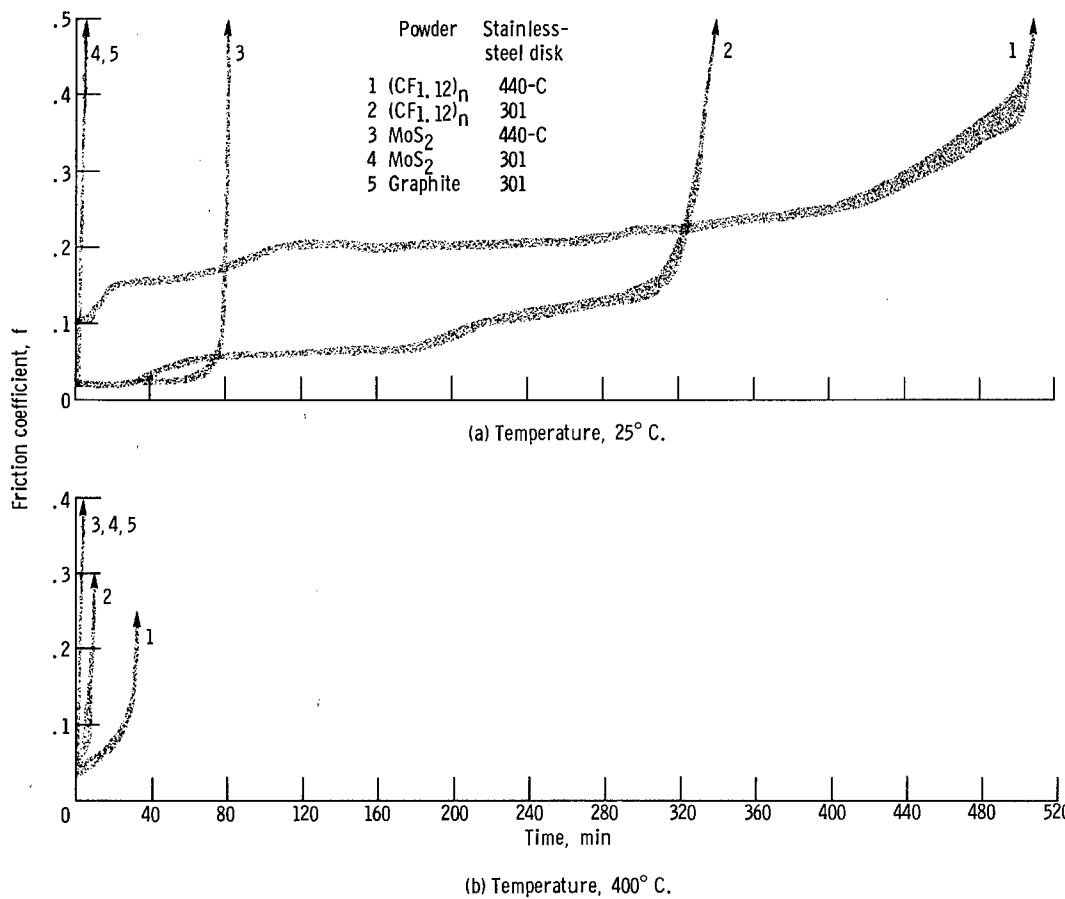

Figure 8. - Variation of friction coefficient with time for burnished films of graphite fluoride ((CF_{1.12})_n), molybdenum disulfide, and graphite at 25° and 400° C. Riders, 440-C stainless steel; linear sliding speed, 1.6 meters per second; load, 500 grams; atmosphere, dry air (moisture content, 20 ppm).

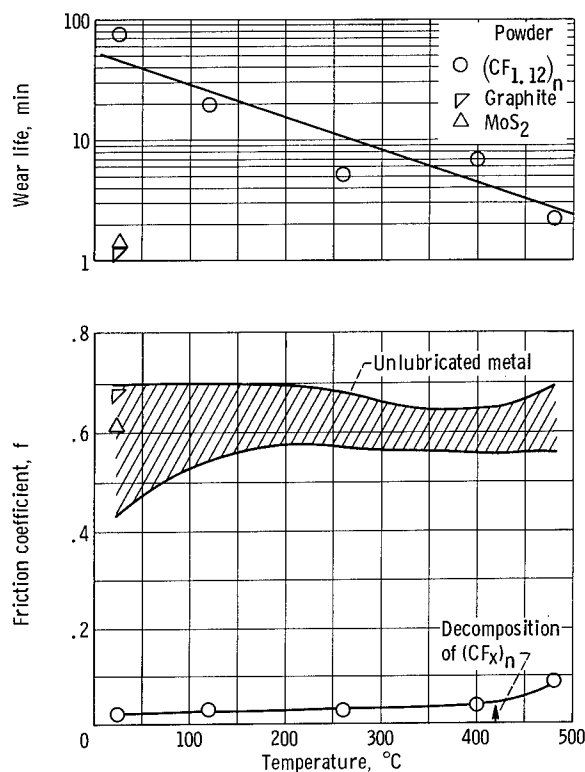

Figure 9. - Effect of temperature on wear life and friction coefficient of graphite fluoride $(CF_{1.12})_n$, graphite, and molybdenum disulfide powders burnished on glass-peened 301 stainless-steel disks. Riders, 440 C stainless steel; linear sliding speed, 1.6 meters per second; load, 500 grams; atmosphere, dry argon (moisture content, 20 ppm).

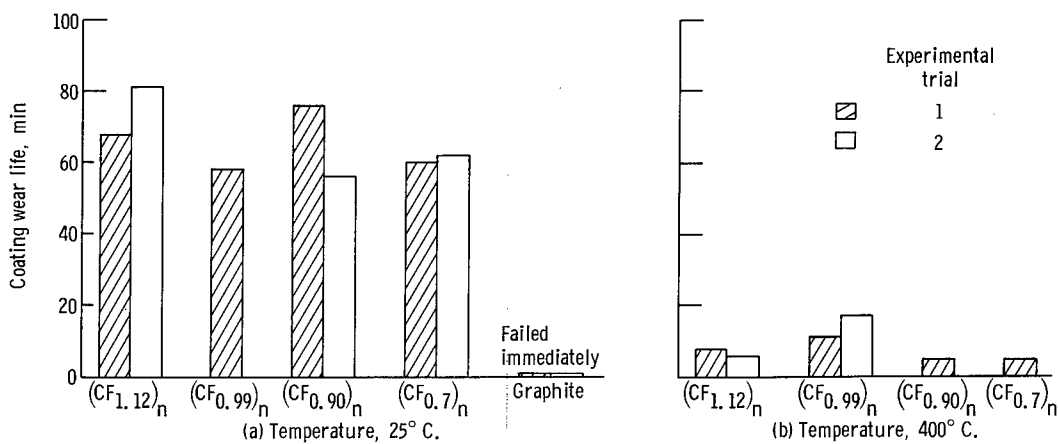

Figure 10. - Effect of fluorine content on wear life of graphite fluoride $(CF_x)_n$ and graphite films burnished on glass-peened 301 stainless-steel disk run at 25° and 400° C. Riders, 440-C stainless steel; linear sliding speed, 1.6 meters per second; load, 500 grams; atmosphere, dry argon (moisture content, 20 ppm).