

AD _____

Award Number: DAMD17-98-1-8090

TITLE: Identification of Proteins Required for Repair of Double-Strand Chromosome Breaks, a Predisposing Factor in Breast Cancer

PRINCIPAL INVESTIGATOR: Jessica Jones
Hiroshi Nakai, Ph.D.

CONTRACTING ORGANIZATION: Georgetown University
Washington, DC 20057

REPORT DATE: June 2000

TYPE OF REPORT: Annual Summary

PREPARED FOR: U.S. Army Medical Research and Materiel Command
Fort Detrick, Maryland 21702-5012

DISTRIBUTION STATEMENT: Approved for Public Release;
Distribution Unlimited

The views, opinions and/or findings contained in this report are those of the author(s) and should not be construed as an official Department of the Army position, policy or decision unless so designated by other documentation.

DTIC QUALITY INSPECTED 4
20001013 087

REPORT DOCUMENTATION PAGEForm Approved
OMB No. 074-0188

Public reporting burden for this collection of information is estimated to average 1 hour per response, including the time for reviewing instructions, searching existing data sources, gathering and maintaining the data needed, and completing and reviewing this collection of information. Send comments regarding this burden estimate or any other aspect of this collection of information, including suggestions for reducing this burden to Washington Headquarters Services, Directorate for Information Operations and Reports, 1215 Jefferson Davis Highway, Suite 1204, Arlington, VA 22202-4302, and to the Office of Management and Budget, Paperwork Reduction Project (0704-0188), Washington, DC 20503

1. AGENCY USE ONLY (Leave blank)**2. REPORT DATE**

June 2000

3. REPORT TYPE AND DATES COVERED

Annual Summary (15 May 99 - 14 May 00)

4. TITLE AND SUBTITLE

Identification of Proteins Required for Repair of Double-Strand Chromosome Breaks, a Predisposing Factor in Breast Cancer

5. FUNDING NUMBERS

DAMD17-98-1-8090

6. AUTHOR(S)Jessica Jones
Hiroshi Nakai, Ph.D.**7. PERFORMING ORGANIZATION NAME(S) AND ADDRESS(ES)**Georgetown University
Washington, DC 20057**E-MAIL:**

nakai@georgetown.edu

8. PERFORMING ORGANIZATION REPORT NUMBER**9. SPONSORING / MONITORING AGENCY NAME(S) AND ADDRESS(ES)**U.S. Army Medical Research and Materiel Command
Fort Detrick, Maryland 21702-5012**10. SPONSORING / MONITORING AGENCY REPORT NUMBER****11. SUPPLEMENTARY NOTES****12a. DISTRIBUTION / AVAILABILITY STATEMENT**

Approved for public release; distribution unlimited

12b. DISTRIBUTION CODE**13. ABSTRACT (Maximum 200 Words)**

Defects in repair of double-strand chromosomal breaks (DSB) are critical factors in familial and sporadic breast tumors. In model bacterial systems, such lesions can be ascribed to defects in homologous recombination proteins, which can support chromosomal replication by promoting restart of DNA synthesis when replication forks become arrested. This project has focused on developing a bacterial model for DSB repair by characterizing the enzymatic apparatus needed to initiate DNA replication on recombination intermediates. *Escherichia coli* PriA protein was found to play a critical function in the transition from recombination to DNA replication. PriA specifically binds to forked DNA structures created by recombination or replication fork arrest and promotes the assembly of protein components needed to load the major replicative helicase DnaB onto the template, a critical step in initiation. DnaB requires single-stranded DNA to bind, and this could be created by the helicase action of PriA, an activity that is suppressed by single-stranded binding protein if a duplex opening is already available. These data indicate that PriA can function in the repair of damaged DNA templates by promoting assembly of replication proteins on a wide variety of forked templates, preventing catastrophic loss or alteration of genetic information.

14. SUBJECT TERMS

Breast Cancer

15. NUMBER OF PAGES

35

16. PRICE CODE**17. SECURITY CLASSIFICATION OF REPORT**

Unclassified

18. SECURITY CLASSIFICATION OF THIS PAGE

Unclassified

19. SECURITY CLASSIFICATION OF ABSTRACT

Unclassified

20. LIMITATION OF ABSTRACT

Unlimited

NSN 7540-01-280-5500

Standard Form 298 (Rev. 2-89)
Prescribed by ANSI Std. Z39-18
298-102

FOREWORD

Opinions, interpretations, conclusions and recommendations are those of the author and are not necessarily endorsed by the U.S. Army.

___ Where copyrighted material is quoted, permission has been obtained to use such material.

___ Where material from documents designated for limited distribution is quoted, permission has been obtained to use the material.

___ Citations of commercial organizations and trade names in this report do not constitute an official Department of Army endorsement or approval of the products or services of these organizations.

N/A In conducting research using animals, the investigator(s) adhered to the "Guide for the Care and Use of Laboratory Animals," prepared by the Committee on Care and use of Laboratory Animals of the Institute of Laboratory Resources, national Research Council (NIH Publication No. 86-23, Revised 1985).

N/A For the protection of human subjects, the investigator(s) adhered to policies of applicable Federal Law 45 CFR 46.

N/A In conducting research utilizing recombinant DNA technology, the investigator(s) adhered to current guidelines promulgated by the National Institutes of Health.

N/A In the conduct of research utilizing recombinant DNA, the investigator(s) adhered to the NIH Guidelines for Research Involving Recombinant DNA Molecules.

N/A In the conduct of research involving hazardous organisms, the investigator(s) adhered to the CDC-NIH Guide for Biosafety in Microbiological and Biomedical Laboratories.

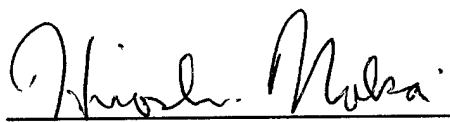
 6/10/00

PI - Signature Date

Table of Contents

Cover.....	1
SF 298.....	2
Foreword.....	3
Introduction.....	5
Body.....	6-8
Key Research Accomplishments.....	9
Reportable Outcomes.....	10
Appendices.....	11

Introduction:

Genetic defects in breast tumors frequently involve mutations in both oncogenes and tumor suppressor genes. Genes involved in the repair of DNA can be classified as tumor suppressor genes, but thus far only genes required for one type of DNA repair, single-base mismatch repair, have been fully characterized in humans. While defects in these genes appear to play a role in a small number of breast tumors, defects in repair of double strand chromosome breaks (DSBs) are emerging as important factors both in familial and sporadic breast tumors. We have focussed on development of a bacterial model for repair of DSBs by replication coupled to homologous recombination, and such a system will likely provide insight into the mechanism of DSB repair in humans. The reconstituted system for bacteriophage Mu replication by transposition has been an invaluable tool in this process. During Mu transposition, strand exchange catalyzed by the phage-encoded transposase MuA leads to formation of a branched DNA structure with a potential replication fork at either end of the transposing DNA element, similar to the branched intermediates created during homologous recombination. Bacterial proteins including the replicative helicase DnaB and DNA polymerase III holoenzyme then assemble a replisome at one end of this substrate and commence semi-discontinuous DNA synthesis from one end to the other. Like replication coupled to recombination on the bacterial chromosome, initiation of bacteriophage Mu replication is independent of the chromosomal initiator protein DnaA, suggesting that bacteriophage Mu may harness the cellular apparatus required for coupling replication with recombination. Our finding that the *Escherichia coli* PriA protein was required for Mu replication by transposition both *in vivo* and *in vitro* supported this hypothesis. Previous to our work, PriA had been hypothesized to couple replication with homologous recombination based on genetic evidence and on the role of PriA in assembly of a primosome for bacteriophage ϕ X174 complementary strand synthesis. Our work provided the first definitive biochemical evidence that PriA could couple replication with recombination.

Report Body

Summary of Research Progress:

This report summarizes the accomplishments of Jessica M. Jones, who was awarded this predoctoral fellowship grant. Last year she was granted the PhD degree and moved on to a postdoctoral position at the National Institutes of Health. Therefore, we requested and were granted a one-year extension of this grant so that we could find a suitable replacement for Dr. Jones. This report summarizes her total accomplishments while supported by this grant. She did continue some experimental work in the past year in order to complete work for another paper, and therefore, we focus primarily on those accomplishments.

Her thesis work involved the identification of key factors involved in bacteriophage Mu DNA replication, a process by which a viral genome is replicated by transposition. In this process a phage-encoded transposase catalyzes the integration of Mu DNA ends to target DNA to form a forked DNA structure. Mu DNA replication is initiated on this template, involving an orderly transition from a recombination apparatus to a replication apparatus, which is essentially identical to the one found at the host replication fork. Dr. Jones found that this transition from recombination to replication involves components (PriA, PriB, PriC, DnaT, DnaB, and DnaC) of a mutiprotein priming apparatus known as the ϕ X74-type primosome, which had been hypothesized by Dr. Tokio Kogoma to play a key role in linking homologous recombination to DNA replication. As Dr. Jones was obtaining this data, the idea had been emerging that the linkage of recombination and replication functions plays a critical function in ensuring proper replication of cellular chromosomes. This thinking was brought about by the realization that a replication fork has a high probability of becoming arrested before completing the replication of a replicon, producing lesions such as DSBs. Such lesions can play a critical factor in diseases such as breast cancer, and therefore, it was important to characterize an enzymatic apparatus involved in repairing such lesions and the mechanisms involved in such reactions. Dr. Jones's work revealed that the strategy employed in the Mu life cycle is to create through transposition a forked structure that resembles the product of an arrested fork, thus recruiting the very host apparatus involved in repairing such lesions and restarting DNA synthesis. Thus she was able to use the Mu replication system as an effective probe for mechanisms associated with this apparatus.

By the end of the first year of the funding period, she completed characterization of how the primosomes promote initiation of DNA synthesis at the Mu fork. The PriA protein has helicase activity that allows it to move 3' to 5' along single-stranded DNA. But the function of this helicase had heretofore been a mystery. Dr. Jones determined that this helicase could play a critical function in creating a single-stranded binding site for the major replicative helicase DnaB on the lagging strand template. PriA was found to translocate 3' to 5' along the lagging

strand template to expose single-stranded DNA, and tightly coupled to this process, the other components of the primosome assemble on the DNA and DnaB binds to the lagging strand template, initiating DnaB's translocation along that DNA in the opposite direction (5' to 3'). This process leads to the assembly of the replicase, the DNA polymerase III holoenzyme, and the initiation of DNA replication.

In the past year, our work has focused on how the PriA helicase action is activated. Dr. Jones found that even though PriA helicase readily participated in the initiation of Mu DNA replication, the helicase was not efficiently activated at the naked Mu fork, in which the template was deproteinized by phenol extraction. Once the transposase forms the Mu fork, it remains tightly bound to the fork and protects it from action by host enzymes. A molecular chaperone ClpX activates this transposase's latent function as a molecular matchmaker, which in turn promotes the assembly of a prereplisome at the Mu fork. This nucleoprotein complex apparently activates PriA helicase action on the lagging strand side of the fork.

Further work on model forked DNA substrates by Dr. Jones indicated the conditions needed to activate PriA helicase. In the absence of a prereplisome complex, exposure of 3 nucleotides or more of single-stranded DNA at the fork could facilitate translocation of PriA along that strand. Moreover, the presence of single strand binding protein (SSB) at the fork could prevent initiation of PriA helicase action on the DNA strand to which SSB is bound. Once PriA initiated translocation along DNA, SSB could not inhibit helicase action. The results indicated that PriA is largely suppressed on structures such as the D-loop, which are products of homologous strand exchange and which already have extensive single-stranded DNA for binding of DnaB. The PriA helicase activity endows the primosome with the ability to load DnaB onto a wide range of forked DNA templates, including the Mu fork and arrested replication forks that may not have single-stranded DNA on the lagging strand side of the fork.

Summary of Training:

Dr. Jones's thesis work has so far resulted in 3 papers as first author in the *EMBO Journal*, *The Journal of Biological Chemistry*, and *The Journal of Molecular Biology*. Her work has also resulted in a Microreview in *Molecular Microbiology*. She was awarded the PhD degree with distinction from Georgetown University.

The work she accomplished under the support of this grant has earned her international recognition. She was an invited speaker at a workshop for the 1999 Keystone Symposium on DNA Replication and Recombination. She was also rewarded the 1999 Nat Sternberg Thesis Prize, an international award given for outstanding predoctoral work in the field of prokaryotic molecular biology. In acceptance of this award, she was an invited speaker at the Molecular Genetics of Bacteria and Phages Meeting in August, 1999. This led to the invitation to write an

Microreview on mechanisms that link recombination and replication in *Molecular Microbiology*.

She is now conducting postdoctoral work in the laboratory of Dr. Martin Gellert at the National Institutes of Health. She has been awarded the Damon Runyon-Walter Winchell Cancer Fund Postdoctoral Fellowship.

Key Research Accomplishments

- The *Escherichia coli* PriA protein couples replication with recombination.
- PriA is absolutely required for bacteriophage Mu replication by transposition *in vivo* and *in vitro*.
- PriA recognizes the forked DNA intermediate created by strand exchange during homologous or non-homologous recombination or by replication fork collapse. This recognition is independent of sequence.
- The helicase activity of PriA contributes significantly to bacteriophage Mu replication by transposition.
- The helicase and primosome assembly activities of PriA can be coupled, allowing PriA to catalyze primosome assembly on forked intermediates that would otherwise lack sufficient single-stranded DNA.
- The helicase activity of PriA is confined primarily to substrates where insufficient single-stranded DNA is available for primosome assembly, such as collapsed replication fork structures, and is less active on substrates where ample single-stranded DNA is available, such as D-loop homologous recombination intermediates.
- Proteins such as SSB bound on forked templates regulate how PriA helicase activity is activated.
- Activation of PriA helicase on some templates such as the Mu fork require additional cellular factors.

Reportable Outcomes

Manuscripts:

Duplex opening by primosome protein PriA for replisome assembly on a recombination intermediate. J. M. Jones and H. Nakai (1999), *J. Mol. Biol.*, **289**:503-515.

PriA and phage T4 gp59: Factors that promote DNA replication on forked DNA substrates J. M. Jones and H. Nakai (2000), *Mol. Microbiol.* **36**, 519-527

Regulation of *Escherichia coli* PriA helicase activity by DNA structure and single strand binding protein. J. M. Jones and H. Nakai, *manuscript in preparation*.

Degrees Obtained:

Doctor of Philosophy in Biochemistry and Molecular Biology conferred with distinction upon Jessica M. Jones, April 30, 1999

Employment Received:

IRTA Fellowship from the NIH/NIDDK awarded to Dr. Jessica M. Jones. Dr. Jones will perform research in the area of mammalian DSB repair in the laboratory of Dr. Martin Gellert.

Awards Received

1999 International Nat Sternberg Prize, for outstanding predoctoral work in the field of prokaryotic molecular biology

Damon Runyon-Walter Winchell Postdoctoral Fellowship (1999-2002)

APPENDIX (Award Number: DAMD17-98-1-8090)

Duplex opening by primosome protein PriA for replisome assembly on a recombination intermediate. J. M. Jones and H. Nakai (1999), *J. Mol. Biol.*, *289*:503-515.

PriA and phage T4 gp59: Factors that promote DNA replication on forked DNA substrates J. M. Jones and H. Nakai (2000), *Mol. Microbiol.* *36*, 519-527

MicroReview

PriA and phage T4 gp59: factors that promote DNA replication on forked DNA substrates

Jessica M. Jones[†] and Hiroshi Nakai*

*Department of Biochemistry and Molecular Biology,
Georgetown University Medical Center,
331 Basic Science Building, 3900 Reservoir Road NW,
Washington DC 20007, USA.*

Summary

The initiation of DNA synthesis on forked DNA templates is a vital process in the replication and maintenance of cellular chromosomes. Two proteins that promote replisome assembly on DNA forks have so far been identified. In phage T4 development the gene 59 protein (gp59) assembles replisomes at D-loops, the sites of homologous strand exchange. Bacterial PriA protein plays an analogous function, most probably restarting replication after replication fork arrest with the aid of homologous recombination proteins, and PriA is also required for phage Mu replication by transposition. Gp59 and PriA exhibit similar DNA fork binding activities, but PriA also has a 3' to 5' helicase activity that can promote duplex opening for replisome assembly. The helicase activity allows PriA's repertoire of templates to be more diverse than that of gp59. It may give PriA the versatility to restart DNA replication without recombination on arrested replication forks that lack appropriate duplex openings.

Introduction

A key step in cellular proliferation is the assembly of replisomes at chromosomal origins, a process promoted by initiator proteins that co-ordinate DNA replication with the cell cycle. In recent years, investigators have been finding that initiation of DNA replication at pre-existing forked templates created by strand exchange for recombination and by replication fork arrest can be just as

important for proper chromosome replication and maintenance, and initiators suited to this purpose have been identified both in bacterial cells and in phage systems. Such initiators recognize DNA forks and promote loading of replicative helicases. Together with initiators acting at chromosomal origins, fork-dependent initiators may be critical components of the replication apparatus in all cells.

Phage T4 possesses a phage-specific factor (gp59) for coupling recombination and replication

The linkage of DNA recombination and replication was first extensively examined in bacteriophage systems. Coupling of homologous strand exchange to initiation of DNA replication was originally suggested by G. Mosig as a means of replicating the terminally redundant ends of the linear bacteriophage T4 genome (Luder and Mosig, 1982; Mosig, 1987; 1998). Early T4 DNA replication is initiated from several internal origins where RNA polymerase transcripts at R-loops serve as the primers for leading strand synthesis. DNA synthesis emanating from these origins cannot fully replicate the ends of T4 because there is no means of priming DNA synthesis on the very end of the lagging strand template. Recombination-dependent replication allows these ends to be replicated. In a process catalysed by the phage-encoded UvsX recombinase and UvsY accessory protein, single-stranded 3' ends of T4 invade homologous regions to form D-loops (Fig. 1A), creating forks at which DNA replication can be initiated. The loading of the replicative helicase (gp41 in this case) is a universally important step in replisome assembly, and phage T4 encodes a protein, gene 59 protein (gp59), designed for this purpose (Barry and Alberts, 1994).

T4 gp59 was originally identified based on its DNA replication arrest phenotype for bacteriophage T4 growth. Its primary activity appears to be loading of gp41 onto single-stranded DNA coated with phage-encoded single-strand binding protein gp32 (Barry and Alberts, 1994). The requirement for gp59 during recombination-dependent T4 DNA replication (Mosig, 1998) indicates that it functions in loading the helicase onto the single-stranded displaced strand of a D-loop, the strand that will become the lagging

Received 15 February, 2000; accepted 17 February, 2000. [†]Present address: Laboratory of Molecular Biology, National Institute of Diabetes Digestive and Kidney Diseases, National Institutes of Health, Building 5 Room 314, Bethesda MD 20892-0560, USA. *For correspondence. E-mail nakai@bc.georgetown.edu; Tel. (+1) 202 687 1442; Fax (+1) 202 687 7186.

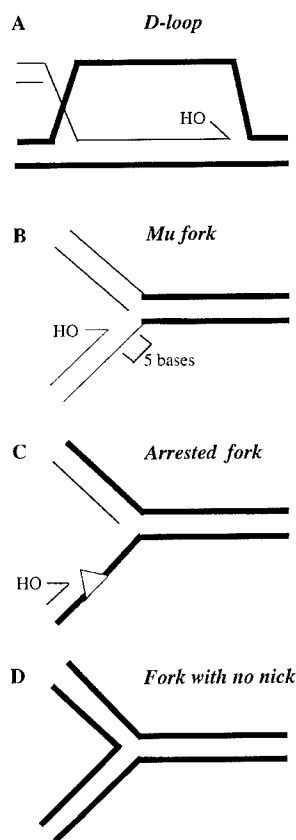

Fig. 1. Fork DNA structures. The 3'-OH ends that can potentially prime leading strand synthesis are depicted as half arrows; the bottom strand of each fork is the template for leading strand synthesis.

A. Forks at a D-loop, an intermediate in homologous recombination. The invading strand (thin line) will become the leading strand primer of the rightward fork. The displaced strand will become the lagging strand template of this fork. The leftward fork must be resolved by branch migration/resolution proteins not discussed in this review.

B. The Mu fork; two such forks are created during transposition. Mu DNA is depicted by very thick lines; target DNA and host DNA flanking the Mu element are depicted by thin lines. The primer for leading strand synthesis is provided by target DNA. This structure is primarily duplex with a 5 base opening between the leading strand primer and the fork junction and no single-stranded DNA on the lagging strand template.

C. Arrested replication fork resulting from a lesion (triangle) blocking leading strand synthesis. This structure is likely to have a primarily duplex lagging strand arm, but may include a large gap on the leading strand template.

D. Three-armed DNA fork with no nick at the fork junction. This structure is not bound by PriA.

strand template for DNA replication. In theory, this activity would also allow gp59 to assist in the origin-dependent phase of replication by loading the helicase onto R-loops. The DNA binding activity of gp59 is consistent with its role in helicase loading on forked substrates like D-loops and R-loops that include a region of single-stranded DNA on the lagging strand template. It can bind both single-stranded and double-stranded DNA, but its affinity is highest for forked DNA (Mueser *et al.*, 2000). Recent

solution of the gp59 crystal structure reveals that it is a two-domain protein with multiple basic patches suitable for DNA binding (Mueser *et al.*, 2000). The first three α -helices in gp59 fold in a manner nearly identical to the high mobility group (HMG) family of minor groove binding proteins. A model based on this structure proposes that gp59 nestles within the fork at a D-loop with the HMG-like motif separating the homologous strands at the fork junction. This model also suggests that gp59 interacts with the displaced single strand, the invading strand duplex and the duplex ahead of the fork, consistent with its ability to bind both single- and double-stranded DNA.

In addition to binding forked DNA, gp59 interacts with multiple phage proteins to promote replisome assembly. It can bind gp32 and gp41 simultaneously (Morrical *et al.*, 1994) and can attract either gp41 or gp32 to a DNA fork (C. Jones, T. Mueser and N. Nossal, personal communication). These properties would allow gp59 to recognize a D-loop in which the displaced strand is coated with gp32 and to load gp41 onto that strand. However, gp59 has no documented ATPase or helicase activity and does not include a recognizable nucleotide binding motif. This suggests that it is unable to open a DNA duplex to create a single-stranded binding site for gp41.

Phage Mu enlists bacterial proteins for initiation of fork-dependent replication

Bacteriophage Mu also replicates its DNA by a mechanism coupled to recombination (Howe, 1987; Mizuuchi, 1992), but unlike T4, fork recognition and replisome assembly are conducted by a host apparatus that includes the major cellular replicative helicase DnaB (Krukliitis and Nakai, 1994). The fork, which acts as the origin for Mu DNA replication, is created by the phage transposase MuA. During Mu replicative transposition, MuA introduces a nick at each end of the transposing element. The transposon ends are then transferred to target DNA to create an intermediate with a fork at each Mu end (the Mu fork; Fig. 1B; Mizuuchi, 1992; Chaconas *et al.*, 1996). Each fork contains a 3'-OH end of target DNA that can serve as primer for leading strand synthesis, and one of these forks will become the origin for Mu DNA replication. The Mu fork is distinct from the D-loop in that it lacks single-stranded DNA on the lagging strand template, a potential problem for the loading of DnaB, which occupies 20 nucleotides of single-stranded DNA (Bujalowski and Jezewska, 1995). Assembly of a replisome on this template is dependent on the cellular PriA protein together with many of the same proteins that are required for bacterial chromosomal replication (Jones and Nakai, 1997).

Because the phage Mu transposition system relies on host proteins to catalyse DNA replication, it has been an

effective probe for critical components of the host apparatus that assembles the replisome on forked templates. Mechanisms in Mu replication have illustrated not only the role of PriA in replisome assembly on certain types of forked substrates but also the role of transposase and host factors in regulating access of the fork to cellular enzymes. During Mu transposition, the transition from strand exchange to DNA replication can be divided into a number of discrete steps. After strand exchange, MuA remains tightly bound to the Mu fork in an oligomeric transpososome (the strand transfer complex 1 or STC1), and bacterial proteins are required to remove this transpososome and assemble a replisome. The molecular chaperone ClpX can alter quaternary interactions within the STC1 transpososome (Levchenko *et al.*, 1995) and this produces an altered complex (STC2) in which an apparent molecular matchmaker function has been activated (Kruklytis *et al.*, 1996). Still unidentified cellular factors called Mu Replication Factor α_2 (MRF α_2) displace the transpososome on STC2, producing a prereplisome complex (STC3). This prereplisome permits initiation of DNA replication only by specific cellular components that include PriA, DnaT, DnaB, DnaC and the DNA polymerase (pol) III holoenzyme (Jones and Nakai, 1997). PriA can also assemble a replisome on an artificially deproteinized Mu fork in the absence of ClpX and MRF α_2 . However, assembly on this naked template is less efficient than on the intact STC3, suggesting that this prereplisome facilitates PriA-dependent assembly of the replisome.

As discussed in greater detail below, PriA possesses distinct replisome assembly and 3' to 5' helicase activities (Lee and Marians, 1987; Lasken and Kornberg, 1988; Zavitz and Marians, 1992). Mu is completely unable to replicate its DNA in a *priA* null host (Jones and Nakai, 1997) and inactivation of PriA helicase activity by the introduction of a site-specific mutation also results in a partial defect in Mu replication by transposition *in vivo* (Jones and Nakai, 1999). The purified, helicase-inactive mutant protein supports little to no Mu replication in the reconstituted system, but this defect can be alleviated by proteins present in a crude extract (Jones and Nakai, 1999). These data indicate that PriA's replisome assembly activity is essential for initiation of Mu DNA replication and that the helicase activity also promotes this process. On substrates similar to the Mu fork, PriA can unwind the duplex on the lagging strand arm (Jones and Nakai, 1999). This is most probably the result of PriA binding to the lagging strand template at the fork and unwinding in a 3' to 5' direction. With the assistance of additional assembly factors, PriA can promote loading of DnaB while it unwinds the lagging strand duplex, essentially coupling its replisome assembly and helicase activities. This suggests a model in which PriA binds to the lagging strand template on the

prereplisome STC3 and opens the duplex as it promotes loading of DnaB helicase (Fig. 2A). The Mu system is the first in which a role for both PriA's replisome assembly and helicase activities has been demonstrated.

Fork-dependent DNA replication in *Escherichia coli* is supported by PriA

PriA was originally characterized as a component of the ϕ X174-type primosome, a bacterial protein complex that lays down primers for complementary strand synthesis during conversion of single-stranded phage ϕ X174 DNA to the double-stranded replicative form (Wickner and Hurwitz, 1975; Shlomai and Kornberg, 1980a). The construction of knockout strains (*priA1* and *priA2*) in *Escherichia coli* has revealed severe and complex phenotypic effects, which include reduced viability ($\approx 10^2$ -fold), slow growth, aspects of a constantly induced SOS response, UV-hypersensitivity and reduced double-strand break repair (Lee and Kornberg, 1991; Nurse *et al.*, 1991; Masai *et al.*, 1994). PriA is also required for recombination-dependent forms of chromosomal replication as well as for normal levels of assimilation of genetic markers by homologous recombination (Masai *et al.*, 1994; Kogoma *et al.*, 1996). These observations suggest that PriA is the factor that couples replication and recombination in the cell. While PriA is not absolutely required for initiation of chromosomal replication at the origin (*oriC*; Kaguni and Kornberg, 1984), it is clearly vital for normal cell growth.

In *E. coli*, replisome assembly on forked DNA structures is an important part of DNA repair and is a likely means of replication restart when forks emanating from *oriC* fail to complete replication. Such failure can occur for a variety of reasons. Forks may arrest at secondary structure or lesions in the template or may collapse when they encounter a nick or gap. It is estimated that 10–50% of the replication forks initiated at *oriC* during exponential growth phase undergo arrest or collapse (Kuzminov, 1995; Cox, 1998), indicating that replication restart is of vital importance for cell health. Some of the requirements for fork-dependent initiation have been identified through extensive genetic analyses performed in the laboratory of T. Kogoma (reviewed in Kogoma, 1997). Kogoma and colleagues characterized two forms of *oriC*-independent chromosomal replication called inducible and constitutive stable DNA replication (iSDR and cSDR respectively). Like *oriC*-dependent replication, iSDR and cSDR rely on DNA pol III holoenzyme, DnaB and the associated DnaC protein but are independent of the *oriC*-initiator DnaA. Instead, they are characterized by dependence on PriA and DnaT as well as the RecA recombinase (Masai and Arai, 1988; Kogoma, 1997). Kogoma proposed that during iSDR and cSDR the RecA recombinase catalyses

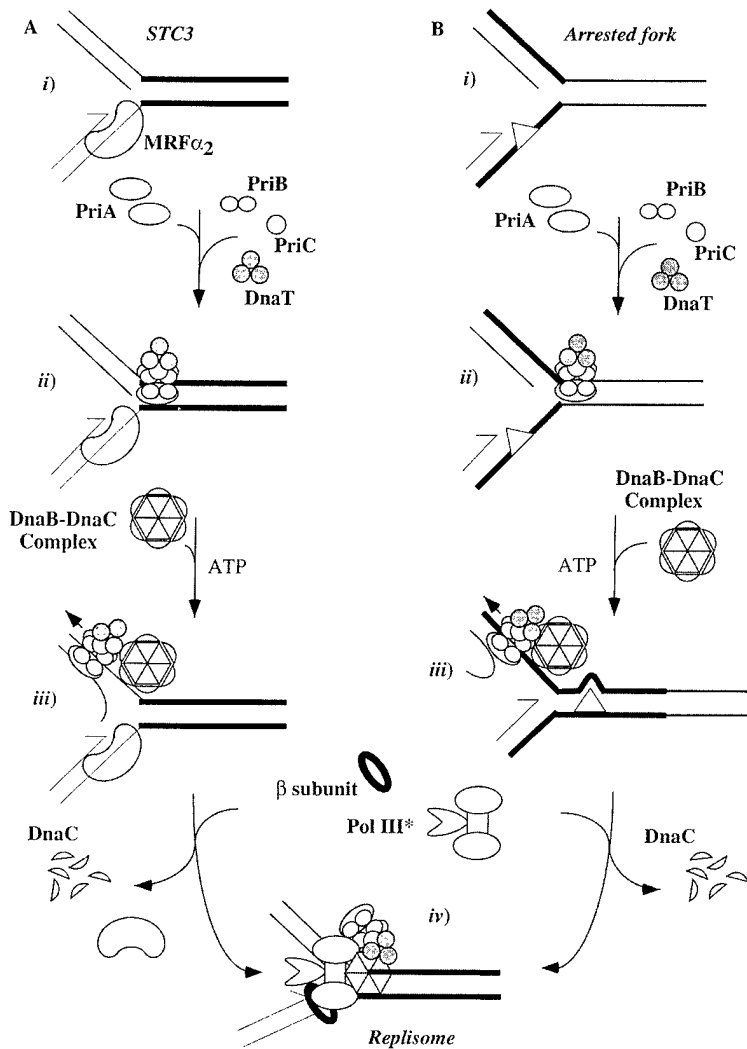

Fig. 2. Model for replisome assembly on DNA forks with duplex lagging strand arms. **A.** Assembly on the bacteriophage Mu prereplisome STC3. (i) STC3 includes host protein components (MRF α_2), which protect the leading strand primer. (ii) PriA binds the lagging strand template and recruits PriB, PriC and DnaT. (iii) The DnaBC complex associates with the PriABC-DnaT-DNA complex, and unwinding by PriA in a 3' to 5' direction creates a binding site for DnaB. (iv) Loading of DnaB, with the exit of DnaC and hypothetically MRF α_2 , leads to the recruitment of DNA pol III holoenzyme and initiation of replication. **B.** Assembly on the arrested replication fork. (i) The obstruction that caused fork arrest is a lesion (triangle) on the leading strand template. Parental strands dissociated by the replicative helicase prior to arrest are depicted with thick lines. Proteins associated with the arrested fork have not been fully characterized but may include RecF, RecO, RecR, RecA and/or SSB (Cox, 1998). (ii) PriA binds the lagging strand template and recruits PriB, PriC and DnaT. (iii) The DnaBC complex associates with the PriABC-DnaT-DNA complex, and unwinding by PriA in a 3' to 5' direction allows for rezipping of the parental duplex and creation of a binding site for DnaB. Reannealing of the parental duplex provides a template for excision repair (not shown). Some trimming of the leading strand primer by a 3' to 5' exonuclease (not shown) may be needed to anneal the parental strands beyond the lesion for repair. (iv) Loading of DnaB, with the exit of DnaC, leads to the recruitment of DNA pol III holoenzyme and initiation of replication (shown for the Mu fork template).

formation of a D-loop or R-loop and that PriA promotes assembly of a replisome on this structure. This model can also be applied to the restart of DNA replication. When replication forks collapse at a single-strand nick in the template, a double-stranded break results. Arrested forks may also be processed into double-stranded breaks (Michel *et al.*, 1997). Resection of the broken arm and homologous strand exchange followed by PriA-dependent replisome assembly at the resulting D-loop allows for reinitiation of DNA replication (Kuzminov, 1995; Kogoma, 1997; Cox, 1998).

Consistent with this model, PriA can promote assembly of a replisome that extends the leading strand primer on structures resembling a D-loop intermediate (Liu *et al.*, 1999). This process is dependent on PriA, PriB, DnaT, DnaB and DnaC. Together with DNA pol III holoenzyme these proteins assemble a highly processive replisome. Interestingly, certain *dnaC* alleles (e.g. *dnaC810*) that can suppress the *priA* null phenotype can promote

PriA-independent replisome assembly on this D-loop substrate (Sandler *et al.*, 1996; Liu *et al.*, 1999). This could result from a gain of function that allows DnaC810 to load the DnaB helicase onto SSB-coated DNA and may not reflect actual fork recognition by DnaC810. Such a mechanism is consistent with DnaC's previously documented cryptic single-stranded DNA binding activity (Learn *et al.*, 1997).

A comparison of the *priA* null phenotype relative to the *recA* null phenotype suggests that PriA's vital function in maintaining cell viability is not solely its role in replisome assembly at D-loops. *recA* null cells show extreme (10^5 -fold) reductions in assimilation of genetic markers by homologous recombination (Clark and Margulies, 1965; Howard-Flanders, 1966; Clark, 1973), reflecting their deficiency in D-loop formation. In the absence of DNA damaging agents, however, *recA* null strains do not show the severe reduction in viability seen in *priA* null strains (Witkin and Roeger-Maniscalco, 1992; Masai *et al.*, 1994).

If all essential PriA activities relied on D-loop formation, then RecA should be equally vital for cell viability, but this is not the case. One possible explanation for the more severe phenotype of *priA* null strains is that the loss of viability is caused by the accumulation of D-loops. Alternatively, PriA's function in replisome assembly may be less dispensable than RecA's function in forming the forked template. Current thinking is that a role in replication restart may be the most vital function provided by recombination proteins for cell viability. Whereas the various recombination proteins may allow several pathways for establishing a forked template to restart DNA replication, inactivation of PriA may leave the cell without an efficient mechanism for repairing arrested forks. PriA's ability to support replisome assembly during bacteriophage Mu DNA replication by transposition (Jones and Nakai, 1997) indicates that it can promote initiation of replication on fork structures other than D-loop recombination intermediates. As discussed further below, we and others propose that PriA can promote replisome assembly on arrested fork structures without the requirement for homologous strand exchange to restart DNA replication.

Because arrested replication forks may not always be processed into double-strand breaks, it is possible that restart takes place directly on the arrested fork. Fork arrest creates structures distinct from the D-loop, without the extensive single-stranded DNA on the lagging strand side of the fork needed to load the DnaB helicase. DnaB, which translocates 5' to 3' along the lagging strand template, is not strongly affected by obstructions that block progression of the leading strand polymerase (Oh and Grossman, 1987). When the polymerase encounters an obstacle on the leading strand template, lagging strand synthesis may continue for one or more additional rounds before coming to a stop. Such arrest produces a fork with a single-stranded gap on the leading strand arm and a primarily duplex lagging strand arm (Fig. 1C). This structure has been observed directly in experiments using damaged DNA templates replicated by eukaryotic DNA polymerases (Svoboda and Vos, 1995; Cordeiro-Stone *et al.*, 1999). If DnaB becomes dissociated from the arrested fork or is otherwise not active for reassembly of the replisome, it must be reloaded before replication can resume. The arrested fork structure is analogous to the Mu fork in that both lack single-stranded DNA on the lagging strand side. Thus, reloading of DnaB on the arrested fork may require duplex opening. In a manner analogous to its action at the Mu fork, PriA helicase activity could function in producing the necessary duplex opening. Such unwinding coupled to loading of DnaB has been observed on synthetic forks that have the structure of arrested forks (Jones and Nakai, 1999), and this mechanism would allow PriA to restart DNA replication directly on arrested forks without D-loop formation.

Alignment of *priA* gene sequences from diverse species including *Bacillus subtilis*, *Borrelia burgdorferi*, *Chlamydia trachomatis*, *Chlamydomonas pneumoniae*, *E. coli*, *Helicobacter pylori* J99, *Lactobacillus casei*, *Rickettsia prowazekii*, *Synechocystis* sp. and *Treponema pallidum* reveals that DNA helicase motifs within the PriA protein have been highly conserved. (GenBank accession numbers for these *priA* genes are as follows: gi3183549, gi2687882, gi3329242, gi4377246, gi216620, gi4155576, gi3201533, gi3861089, gi1653581 and gi3322498. Analysis was performed using CLUSTAL W multiple sequence alignment.) This is interesting as the role of PriA's helicase activity in supporting PriA-dependent functions in the cell has been something of a mystery. When supplied in *trans*, helicase-inactive *priA* alleles with mutations in the Walker box nucleotide binding motif (*priA K230R*, *priA K230A* and *priA K230D*) restore apparently wild-type levels of viability and cell morphology to *priA* null strains (Zavitz and Marians, 1992; Kogoma *et al.*, 1996; Sandler *et al.*, 1996; Masai *et al.*, 1999). Two of these alleles allow strains to assimilate genetic markers by homologous recombination, albeit at 30–50% of the level of wild type (Zavitz and Marians, 1992; Kogoma *et al.*, 1996; Sandler *et al.*, 1996), while the third, *priA K230D*, supports only low levels of iSDR (Masai *et al.*, 1999). Work in the Mu system suggests a role for the helicase and also indicates that other proteins in the cell can compensate for the lack of PriA helicase activity (Jones and Nakai, 1999). This may explain in part why inactivation of PriA's helicase produces such a mild phenotype relative to the *priA* null mutation. The proteins that compensate for the loss of PriA helicase activity are not required for replisome assembly when PriA helicase is intact (Jones and Nakai, 1999), suggesting that under normal circumstances the helicase and replisome assembly activities work together.

A comparison of PriA and gp59

An examination of the similarities and differences between PriA and gp59 underscores the hypothesis that PriA is designed for tasks in addition to promoting replisome assembly on D-loops. PriA is approximately three times the size of gp59 and its DNA binding domains have not been fully demarcated. Because there is no apparent sequence conservation between the proteins and there is no structural data available for PriA, it is difficult to speculate whether PriA and gp59 will share similar fork binding motifs. However, the DNA binding activities of PriA and gp59 are alike in many respects, consistent with their both being proteins capable of promoting replisome assembly on forked structures.

PriA and gp59 possess similar DNA binding activities. Just as the structure of gp59 suggests that it splits the fork, possibly increasing the bend at the fork junction

(Mueser *et al.*, 2000), PriA may specifically recognize and stabilize the bend at the junction of a DNA fork (Nurse *et al.*, 1999). PriA binds with high affinity to forked DNA structures although it can also bind with lower affinity to single-stranded and double-stranded DNA. Like gp59, PriA binds to synthetic forks with one, two or three duplex arms and it can bind to forks in which either the leading or lagging strand arm is single stranded (McGlynn *et al.*, 1997; Jones and Nakai, 1999; Mueser *et al.*, 2000). PriA also binds to the Mu fork (Jones and Nakai, 1999), a structure with three duplex arms in which the primer for leading strand synthesis is recessed five bases from the fork junction (Fig. 1B). Regardless of other structural attributes, a certain amount of flexibility at the fork is required for optimal binding. On forks in which all three arms are duplex there is an absolute requirement for a nick at the fork junction; that is, the structure shown in Fig. 1D is not bound by PriA (McGlynn *et al.*, 1997; Nurse *et al.*, 1999). Consistent with this finding, PriA cannot bind to Holliday junctions (McGlynn *et al.*, 1997; Nurse *et al.*, 1999), which are four armed, fully duplex structures with no nick at the fork and much less flexibility than three-armed junctions (Ma *et al.*, 1986).

Both PriA and gp59 promote loading of replicative helicases that can attract their cognate primase components to form primosomes. As was mentioned earlier, gp59 loads the gp41 replicative helicase onto gp32-coated single-stranded DNA; gp41 then recruits the phage primase (Barry and Alberts, 1994; Spacciapoli and Nossal, 1994). PriA initiates assembly of a more complex primosome in a process requiring up to seven primosome and accessory proteins. Assembly of this primosome has been best characterized during the initiation of ϕ X174 complementary strand synthesis. During this process, PriA binds to a specific primosome assembly site on single-stranded ϕ X174(+) DNA coated with SSB (Shlomai and Kornberg, 1980b). This is followed by the addition of PriB, PriC and DnaT to the complex (Ng and Mariani, 1996a; b). The DnaB replicative helicase is then recruited from the DnaB₆-6DnaC complex, completing assembly of the preprimosome. A transient interaction between DnaB and DnaG primase forms the complete primosome (Tougo *et al.*, 1994).

Conceptually, these mechanisms are similar in that both PriA, with the help of other preprimosome components, and gp59 alleviate inhibition of helicase loading by the respective single-strand binding protein. Both DnaB and gp41 can load directly onto naked single-stranded DNA, and the presence of *E. coli* SSB or gp32, respectively, inhibits this direct binding (LeBowitiz and McMacken, 1986; Barry and Alberts, 1994; Morrical *et al.*, 1994). Both PriA and gp59 bind to DNA with bound single-strand binding protein, promoting processes that specifically overcome this inhibition.

PriA possesses a conserved helicase activity whereas gp59 apparently does not. This helicase activity allows PriA to promote primosome and replisome assembly on diverse templates such as D-loops and Mu forks, while gp59 activity is presumably restricted to templates such as D-loops that already have a duplex opening. PriA helicase activity is dispensable for assembly of a replisome on a D-loop and may actually decrease the efficiency of this process (Liu *et al.*, 1999). Conservation of PriA helicase activity suggests that it is advantageous to the cell for PriA to use diverse DNA templates.

Replication fork reactivation

During initiation of replication at *oriC*, the DnaA initiator recognizes the origin, opens the duplex and promotes loading of the replicative helicase DnaB, ensuring that only one round of replication is initiated per cell cycle (Kornberg and Baker, 1992). PriA's ability to recognize origins like the one created by Mu strand transfer, open the duplex and promote loading of DnaB indicates that it has an initiator function analogous to DnaA. In the bacterial cell, PriA's ability to promote duplex opening coupled to replisome assembly may be designed to effect rapid, seamless resumption of replication after replication fork arrest. Such an important role is consistent with the severity and nature of the *priA* null phenotype.

There is ample evidence to suggest that after replication fork collapse or arrest PriA can support reinitiation of replication on D-loop structures formed by homologous strand exchange. The phenotypes of strains inactivated for proteins supporting D-loop formation (e.g. RecA and RecB) suggest that D-loop dependent reinitiation pathways are particularly important under conditions known to obstruct or slow replication fork progression (e.g. UV irradiation or inactivation of the *rep* gene). Such pathways have been described in a number of previous reviews (Kuzminov, 1995; Kogoma, 1997; Cox, 1998). Models independent of D-loop formation have also been proposed. Cox has proposed that following fork arrest, strand exchange by a RecA-RecFOR-dependent pathway introduces a homologous strand at the site of the obstruction to prime leading strand synthesis and bypass the lesion (Cox, 1998). In another model, Seigneur *et al.* (1998) have proposed that the nascent leading and lagging strands at an arrested fork anneal to form a Holliday junction stabilized by RuvAB. The arm formed by the two nascent strands is a substrate for the RecBCD exonuclease, which degrades the arm until the RuvAB complex is displaced, re-establishing the fork. In both models, PriA is suggested as the factor that initiates assembly of the replisome, leading to replication restart. However, neither of the substrates created by the pathways outlined would include large regions of single-stranded DNA on the

lagging strand, suggesting that PriA's helicase activity could contribute to replisome assembly.

We offer an additional model for PriA-dependent replication restart in which PriA directly reactivates the arrested fork without homologous strand exchange or extensive processing. In the presence of SSB, PriA preferentially unwinds the lagging strand duplex on a structure resembling an arrested fork (similar to Fig. 1C) and this unwinding can be coupled to primosome assembly (Jones and Nakai, 1999). This could allow PriA to initiate assembly directly at the site of replication fork arrest (Fig. 2B). If there is a considerable gap between the leading strand primer and the fork junction, unwinding of the lagging strand by PriA may allow the original template strands to reanneal until they reach the leading strand primer (Fig. 2B, step iii). Such 'zipping up' of the parental duplex would theoretically prevent loading of DnaB until the leading strand primer was met, and at this point additional unwinding by PriA would create the necessary duplex opening. Proteins associated with the RecF recombination pathway (RecF, RecR and RecA) are believed to participate in the rapid resumption of replication following UV irradiation (Courcelle *et al.*, 1997; Cox, 1998), and one interesting possibility is that these proteins can aid in reannealing the parental duplex as the lagging strand is unwound by PriA helicase. Such a mechanism would be consistent with the observation that RecF-supported resumption of replication following UV irradiation is dependent on excision repair processes (Courcelle *et al.*, 1999). If homologous strand exchange is not involved in bypassing the template lesion, repair would be essential for restarting DNA replication. Reannealing of the parental duplex would provide the damaged DNA with the template needed for excision repair.

Interestingly, the *recF* function is required for viability of *priA* null strains (Sandler, 1996), but it is unlikely that *recF* plays a function analogous to PriA in replisome assembly. PriA is required for assimilation of genetic markers and initiation of iSDR by the RecF recombination pathway (Kogoma, 1997). Moreover, the phenotype of a *recF* null strain is very mild compared with the *priA* null; *recF* null strains are UV sensitive and exhibit a delay in replication restart after irradiation, but unlike *priA* null strains, they do not show a severe reduction in viability (Horii and Clark, 1973; Courcelle *et al.*, 1997). It has been proposed that recombination proteins RecF, RecR and RecA play a critical part in forming and maintaining the forked structure on which replication will be restarted (Courcelle *et al.*, 1997; Courcelle *et al.*, 1999). The types of forks maintained by these proteins would be good substrates for PriA, allowing reassembly of the replisome. In the absence of RecF, replication could be restarted by other pathways such as the introduction of a double-strand

break and formation of a D-loop (Kuzminov, 1995; Michel *et al.*, 1997). But if PriA is not available to restart DNA replication at the D-loop, RecF may play a critical function in maintaining the fork to allow repair or replication restart by an alternative mechanism. Such a mechanism is most probably inefficient, considering the very low viability of the *priA* null strain.

All of the replication restart pathways presented thus far that do not involve D-loop formation are potentially dependent on PriA helicase activity, and this may seem at odds with the mild phenotype produced by PriA helicase inactivation. It is likely that if PriA's helicase is inactivated, another cellular helicase or exonuclease can create the duplex opening necessary for reloading of DnaB as is suggested by work in the Mu system (Jones and Nakai, 1999). Courcelle and Hanawalt (1999) have found that RecQ and RecJ can process arrested replication forks, degrading the nascent lagging strand. Such a mechanism could provide a duplex opening for loading DnaB in the absence of PriA helicase activity. The inability to create cells with null mutations in both *priA* and *rep* (Seigneur *et al.*, 1998) may also indicate that the two helicases are functionally redundant, Rep helicase being able to compensate for the loss of PriA helicase. Additional experiments will be required to determine which of the helicases, exonucleases or other host factors, are required to compensate for the loss of PriA helicase activity.

Future perspectives

The multiple roles of PriA in normal cellular metabolism are only now becoming clear. PriA as well as proteins originally identified for their roles in homologous recombination clearly play important roles in the replication, repair and maintenance of the chromosome. Whereas T4 gp59 has the attributes needed to promote replisome assembly at a D-loop, PriA is capable of performing additional functions because of its helicase activity. Likewise, T4 gp59 may function primarily in promoting homologous recombination-dependent DNA replication during T4 development whereas PriA's principal function may be in restarting replication following fork arrest or collapse. During this process PriA is likely to encounter various forked structures, including those that have not been formed by homologous strand exchange. Helicase activity allows PriA to cope efficiently with the many diverse DNA structures that have the potential to become active replication forks.

A variety of models have been proposed for the restart of DNA replication at arrested forks (Cox, 1998; Seigneur *et al.*, 1998; Courcelle and Hanawalt, 1999), most of which rely on PriA and overlapping subsets of proteins involved in homologous recombination. The models

discussed thus far are not mutually exclusive; all may be active in the cell. Redundancies among the pathways by which the recombination proteins re-establish the replication fork are evidenced by the observation that the single inactivation of many recombination proteins has little effect on cell viability. It must be remembered also that the involvement of 'homologous recombination' proteins does not mean that all pathways involve homologous strand exchange (Courcelle *et al.*, 1997; Seigneur *et al.*, 1998; Courcelle and Hanawalt, 1999). In contrast to recombination proteins, proteins that assemble replisomes on forked templates apparently play an indispensable function in the cell; loss of PriA function results in severe reduction of viability. The full complement of these recombination and replication functions is probably highly advantageous in nature, providing wild-type cells with a selective advantage over mutants that lack one or more of the redundant replication restart pathways. All cells, whether prokaryotic or eukaryotic, must cope with the problem of arrested forks and thus they all may have the two basic types of initiators for DNA replication; one like DnaA that coordinates initiation at specific chromosomal origins with the cell cycle and the other like PriA that can function at essentially any site on the chromosome having a forked DNA structure. In the future, it will be of interest to examine how and where homologous recombination proteins and fork-specific initiators function relative to the major replication proteins at the advancing replication fork.

Acknowledgements

We would like to thank T. Mueser, N. Nossal, P. Nurse and K. Marians for providing us with manuscripts prior to publication. We thank T. Mueser, N. Nossal, E. Crooke, M. Gellert and T. Paull for critical reading of this manuscript and helpful discussion. Work in the Nakai laboratory is supported by grants from the National Institutes of Health (GM58265 and GM49649). J.M.J. was a recipient of a predoctoral training grant from the Department of Defense Breast Cancer Research Program (DAMD 17-98-1-8090).

References

- Barry, J., and Alberts, B.M. (1994) Purification and characterization of bacteriophage gene 59 protein. A DNA helicase assembly protein involved in DNA replication. *J Biol Chem* **9**: 33049–33062.
- Bujalowski, W., and Jezewska, M.J. (1995) Interactions of *Escherichia coli* primary replicative helicase DnaB protein with single-stranded DNA. The nucleic acid does not wrap around the protein hexamer. *Biochemistry* **34**: 8513–8519.
- Chaconas, G., Lavoie, B.D., and Watson, M.A. (1996) DNA transposition: jumping gene machine, some assembly required. *Curr Biol* **6**: 817–820.
- Clark, A.J. (1973) Recombination deficient mutants of *E. coli* and other bacteria. *Ann Rev Genet* **7**: 67–86.
- Clark, A.J., and Margulies, A.D. (1965) Isolation and characterization of recombination-deficient mutants of *Escherichia coli* K12. *Proc Natl Acad Sci USA* **53**: 451–459.
- Cordeiro-Stone, M., Makhov, A.M., Zaritskaya, L.S., and Griffith, J.D. (1999) Analysis of DNA replication forks encountering a pyrimidine dimer in the template to the leading strand. *J Mol Biol* **289**: 1207–1218.
- Courcelle, J., and Hanawalt, P.C. (1999) RecQ and RecJ process blocked replication forks prior to the resumption of replication in UV-irradiated *Escherichia coli*. *Mol Gen Genet* **262**: 543–551.
- Courcelle, J., Carswell-Crumpton, C., and Hanawalt, P.C. (1997) *recF* and *recR* are required for the resumption of replication at DNA replication forks in *Escherichia coli*. *Proc Natl Acad Sci USA* **94**: 3714–3719.
- Courcelle, J., Crowley, D.J., and Hanawalt, P.C. (1999) Recovery of DNA replication in UV-irradiated *Escherichia coli* requires both excision repair and RecF protein function. *J Bacteriol* **181**: 916–922.
- Cox, M.M. (1998) A broadening view of recombinational DNA repair in bacteria. *Genes Cells* **3**: 65–78.
- Horii, Z., and Clark, A.J. (1973) Genetic analysis of the RecF pathway to genetic recombination in *Escherichia coli* K12: isolation and characterization of mutants. *J Mol Biol* **80**: 327–344.
- Howard-Flanders, P. (1966) Mutants of *Escherichia coli* K12 defective in DNA repair and in genetic recombination. *Genetics* **53**: 1137–1150.
- Howe, M.M. (1987) Phage Mu: An overview. In *Phage Mu*. Symonds, N., Toussaint, A., van de Putte, P., and Howe, M.M. (eds). Cold Spring Harbor, NY: Cold Spring Harbor Laboratory Press, pp. 25–39.
- Jones, J.M., and Nakai, H. (1997) The ϕ X174-type primosome promotes replisome assembly at the site of recombination in bacteriophage Mu transposition. *EMBO J* **16**: 6886–6895.
- Jones, J.M., and Nakai, H. (1999) Duplex opening by primosome protein PriA for replisome assembly on a recombination intermediate. *J Mol Biol* **289**: 503–515.
- Kaguni, J.M., and Kornberg, A. (1984) Replication initiated at the origin (*oriC*) of the *E. coli* chromosome reconstituted with purified enzymes. *Cell* **38**: 183–190.
- Kogoma, T. (1997) Stable DNA replication: Interplay between DNA replication, homologous recombination, and transcription. *Microbiol Mol Biol Rev* **61**: 212–238.
- Kogoma, T., Cadwell, G.W., Barnard, K.G., and Asai, T. (1996) The DNA replication priming protein, PriA, is required for homologous recombination and double-strand break repair. *J Bacteriol* **178**: 1258–1264.
- Kornberg, A., and Baker, T.A. (1992) *DNA Replication*, 2nd edn. New York: W. H. Freeman.
- Krukltis, R., and Nakai, H. (1994) Participation of bacteriophage Mu A protein and host factors in initiation of Mu DNA synthesis *in vitro*. *J Biol Chem* **269**: 16469–16477.
- Krukltis, R., Welty, D.J., and Nakai, H. (1996) ClpX protein of *Escherichia coli* activates bacteriophage Mu transposase in the strand transfer complex for initiation of Mu DNA synthesis. *EMBO J* **15**: 935–944.
- Kuzminov, A. (1995) Collapse and repair of replication forks in *Escherichia coli*. *Mol Microbiol* **16**: 373–384.
- Lasken, R.S., and Kornberg, A. (1988) The primosomal protein *n'* of *Escherichia coli* is a DNA helicase. *J Biol Chem* **263**: 5512–5518.
- Learn, B.A., Um, S.J., Huang, L., and McMacken, R. (1997) Cryptic single-stranded-DNA binding activities of the phage lambda P and *Escherichia coli* DnaC replication initiation

- proteins facilitate the transfer of *E. coli* DnaB helicase onto DNA. *Proc Natl Acad Sci USA* **94**: 1154–1159.
- LeBowitz, J.H., and McMacken, R. (1986) The *Escherichia coli* DnaB replication protein is a DNA helicase. *J Biol Chem* **261**: 4738–4748.
- Lee, M.S., and Marians, K.J. (1987) *Escherichia coli* replication factor Y, a component of the primosome, can act as a DNA helicase. *Proc Natl Acad Sci USA* **84**: 8345–8349.
- Lee, E.H., and Kornberg, A. (1991) Replication deficiencies in *priA* mutants of *Escherichia coli* lacking the primosomal replication *n'* protein. *Proc Natl Acad Sci USA* **88**: 3029–3032.
- Levchenko, I., Luo, L., and Baker, T.A. (1995) Disassembly of the Mu transposase tetramer by the ClpX chaperone. *Genes Dev* **9**: 2399–2408.
- Liu, J., Xu, L., Sandler, S., and Marians, K.J. (1999) Replication fork assembly at recombination intermediates is required for bacterial growth. *Proc Natl Acad Sci USA* **96**: 3552–3555.
- Luder, A., and Mosig, G. (1982) Two alternative mechanisms for initiation of DNA replication forks in bacteriophage T4: priming by RNA polymerase and by recombination. *Proc Natl Acad Sci USA* **79**: 1101–1105.
- Ma, R., Kallenbach, N.R., Sheardy, R.D., and Retrillo, M.L. (1986) Three-arm nucleic acid junctions are flexible. *Nucleic Acids Res* **14**: 9745–9753.
- Masai, H., and Arai, K. (1988) Operon structure of the *dnaT* and *dnaC* genes essential for normal and stable DNA replication of *Escherichia coli* chromosome. *J Biol Chem* **263**: 15083–15093.
- Masai, H., Asai, T., Kubota, Y., Arai, K., and Kogoma, T. (1994) *Escherichia coli* PriA protein is essential for inducible and constitutive stable DNA replication. *EMBO J* **13**: 5338–5345.
- Masai, H., Deneke, J., Furui, Y., Tanaka, T., and Arai, K. (1999) *Escherichia coli* and *Bacillus subtilis* PriA protein essential for recombination-dependent DNA replication: involvement of ATPase/helicase activity of PriA for inducible stable DNA replication. *Biochimie* **81**: 847–857.
- McGlynn, P., Al-Deib, A.A., Liu, J., Marians, K.J., and Lloyd, R.G. (1997) The DNA replication protein PriA and the recombination protein RecG bind D-loops. *J Mol Biol* **270**: 212–221.
- Michel, B., Ehrlich, S.D., and Uzest, M. (1997) DNA double-strand breaks caused by replication arrest. *EMBO J* **16**: 430–438.
- Mizuuchi, K. (1992) Transpositional recombination: Mechanistic insights from studies of Mu and other elements. *Annu Rev Biochem* **61**: 1011–1051.
- Morrill, S.W., Hempstead, K., and Morrill, M.D. (1994) The gene 59 protein of bacteriophage T4 modulates the intrinsic and single-stranded DNA-stimulated ATPase activities of gene 41 protein, the T4 replicative helicase. *J Biol Chem* **269**: 33069–33081.
- Mosig, G. (1987) The essential role of recombination in phage T4 growth. *Annu Rev Genet* **21**: 347–371.
- Mosig, G. (1998) Recombination and recombination-dependent DNA replication in bacteriophage T4. *Annu Rev Genet* **32**: 379–413.
- Mueser, T.C., Jones, C.E., Nossal, N.G., and Hyde, C.C. (2000) Bacteriophage T4 gene 59 helicase assembly protein binds replication fork DNA. The 1.45Å resolution crystal structure reveals a novel α -helical two-domain fold. *J Mol Biol* **296**: 597–613.
- Ng, J.Y., and Marians, K.J. (1996a) The ordered assembly of the ϕ X174-type primosome: Isolation and identification of intermediate protein-DNA complexes. *J Biol Chem* **271**: 15642–15648.
- Ng, J.Y., and Marians, K.J. (1996b) The ordered assembly of the ϕ X174-type primosome: Preservation of primosome composition from assembly through replication. *J Biol Chem* **271**: 15649–15655.
- Nurse, P., Zavitz, K.H., and Marians, K.J. (1991) Inactivation of the *Escherichia coli* PriA DNA replication protein induces the SOS response. *J Bacteriol* **173**: 6686–6693.
- Nurse, P., Liu, J., and Marians, K.J. (1999) Two modes of PriA binding to DNA. *J Biol Chem* **274**: 25026–25032.
- Oh, E.Y., and Grossman, L. (1987) Helicase properties of the *Escherichia coli* UvrAB protein complex. *Proc Natl Acad Sci USA* **84**: 3638–3842.
- Sandler, S.J. (1996) Overlapping functions for *recF* and *priA* in cell viability and UV-inducible SOS expression are distinguished by *dnaC809* in *Escherichia coli* K-12. *Mol Microbiol* **19**: 871–880.
- Sandler, S.J., Samra, H.S., and Clark, A.J. (1996) Differential suppression of *priA2::kan* phenotypes in *Escherichia coli* K-12 by mutations in *priA*, *lexA*, and *dnaC*. *Genetics* **143**: 5–13.
- Seigneur, M., Bidenko, V., Ehrlich, S.D., and Michel, B. (1998) RuvAB acts at arrested replication forks. *Cell* **95**: 419–430.
- Shlomai, J., and Kornberg, A. (1980a) A prepriming DNA replication enzyme of *Escherichia coli*. I. Purification of protein *n'*: a sequence-specific, DNA-dependent ATPase. *J Biol Chem* **255**: 6789–6783.
- Shlomai, J., and Kornberg, A. (1980b) An *Escherichia coli* replication protein that recognizes a unique sequence hairpin within a region of ϕ X174 DNA. *Proc Natl Acad Sci USA* **77**: 799–803.
- Spacciapoli, P., and Nossal, N.G. (1994) Interaction of DNA polymerase and DNA helicase within the bacteriophage T4 replication complex. *J Biol Chem* **269**: 447–455.
- Svoboda, D.L., and Vos, J.H. (1995) Differential replication of a single, UV-induced lesion in the leading or lagging strand by a human cell extract: Fork uncoupling or gap formation. *Proc Natl Acad Sci USA* **92**: 11975–11979.
- Tougo, K., Peng, H., and Marians, K.J. (1994) Identification of a domain of *Escherichia coli* primase required for functional interaction with the DnaB helicase at the replication fork. *J Biol Chem* **269**: 4675–4682.
- Wickner, S., and Hurwitz, J. (1975) Association of ϕ X174 DNA-dependent ATPase activity with an *Escherichia coli* protein, replication factor Y, required for *in vitro* synthesis of ϕ X174 DNA. *Proc Natl Acad Sci USA* **72**: 3342–3346.
- Witkin, E.M., and Roeger-Maniscalco, V. (1992) Overproduction of DnaE protein (α subunit of DNA polymerase III) restores viability in a conditionally inviable *Escherichia coli* strain deficient in DNA polymerase I. *J Bacteriol* **174**: 4166–4168.
- Zavitz, K.H., and Marians, K.J. (1992) ATPase-deficient mutants of the *Escherichia coli* DNA replication protein PriA are capable of catalyzing the assembly of active primosomes. *J Biol Chem* **267**: 6933–6940.

Mutational analysis of the functional motifs of RuvB, an AAA⁺ class helicase and motor protein for Holliday junction branch migration

Hiroshi Iwasaki,^{1,2*} Yong-Woon Han,¹ Takashi Okamoto,¹ Takayuki Ohnishi,¹ Manabu Yoshikawa,¹ Kazuhiro Yamada,¹ Hiroyuki Toh,³ Hiromi Daiyasu,³ Teru Ogura⁴ and Hideo Shinagawa¹

¹Department of Molecular Microbiology, Research Institute for Microbial Diseases, Osaka University, Suita, Osaka 565-0871, Japan.

²PRESTO, JST.

³Department of Bioinformatics, Biomolecular Engineering Research Institute (BERI), Suita, Osaka 565-0874, Japan.

⁴Department of Molecular Cell Biology, Institute of Molecular Embryology and Genetics, Kumamoto University School of Medicine, Kumamoto 862-0976, Japan.

Summary

Escherichia coli RuvB protein, together with RuvA, promotes branch migration of Holliday junctions during homologous recombination and recombination repair. The RuvB molecular motor is an intrinsic ATP-dependent DNA helicase with a hexameric ring structure and its architecture has been suggested to be related to those of the members of the AAA⁺ protein class. In this study, we isolated a large number of plasmids carrying *ruvB* mutant genes and identified amino acid residues important for the RuvB functions by examining the *in vivo* DNA repair activities of the mutant proteins. Based on these mutational studies and amino acid conservation among various RuvBs, we identified 10 RuvB motifs that agreed well with the features of the AAA⁺ protein class and that distinguished the primary structure of RuvB from that of typical DNA/RNA helicases with seven conserved helicase motifs.

Introduction

The Holliday structure, in which two homologous duplex DNA molecules are linked by a cross-over, is thought to be a central intermediate of homologous recombination

Received 8 November, 1999; revised 25 December, 1999; accepted 13 January, 2000. *For correspondence. E-mail iwasaki@biken.osaka-u.ac.jp; Tel. (+81) 6 6879 8319; Fax (+81) 6 6879 8320.

and recombination repair (Holliday, 1964). *Escherichia coli* RuvB protein, together with RuvA, promotes branch migration of Holliday junctions, leading to enlargement of the heteroduplex regions of DNA (Iwasaki *et al.*, 1992; Tsaneva *et al.*, 1992). In the RuvA–RuvB branch migration complex, the stable RuvA tetramer, a Holliday junction-specific binding protein, targets RuvB to the Holliday junction, and RuvB, an intrinsic ATP-dependent DNA helicase with a hexameric ring structure, acts as a molecular motor for branch migration (for reviews see Shinagawa and Iwasaki, 1996; West, 1997). It has been proposed, that the RuvAB-mediated branch migration is a strand exchange reaction in which homologous DNA duplexes are unwound at the junction and rewound with other partner strands while passing through the RuvB hexameric rings that are located diametrically across the RuvA-bound junction (Parsons *et al.*, 1995).

A large number of analyses have revealed the multifunctional properties of the RuvB motor protein. It forms a dimer as a protomer and a hexamer ring as the active form, and binds to RuvA, RuvC resolvase for Holliday junctions, and to DNA (Shiba *et al.*, 1991; Parsons and West, 1993; Mitchell and West, 1994; Hiom and West, 1995; Eggleston *et al.*, 1997; Davies and West, 1998). It also binds and hydrolyses ATP, and its ATPase activity is strongly and synergistically enhanced by RuvA and DNA (Iwasaki *et al.*, 1989; Shiba *et al.*, 1991; Marrione and Cox, 1996). RuvB, together with RuvA, shows a weak but detectable ATP-dependent DNA helicase activity that unwinds a short duplex DNA in the 5' to 3' direction (Tsaneva *et al.*, 1993). These multiple properties suggest that RuvB has several interfaces or motifs which are involved in these functions.

RuvB is a quite unique helicase with respect to its primary structure. Although many DNA and RNA helicases possess seven conserved motifs (Gorbalenya and Koonin, 1993), RuvB does not share significant overall sequence homologies with them, nor even with helicases with a hexameric ring structure, such as *E. coli* DnaB, Rho, T4 gp41, T7 gp4 and SV40 large T antigen. It only shares homologies with Walker motifs A and B, which have been proposed to be involved in the binding of ATP and Mg²⁺. The only helicases with which it displays significant sequence similarity are eukaryotic TIP49a/RUVBL1 and the related TIP49b, whose *in vivo* roles are

JMB



Duplex Opening by Primosome Protein PriA for Replisome Assembly on a Recombination Intermediate

Jessica M. Jones and Hiroshi Nakai

Duplex Opening by Primosome Protein PriA for Replisome Assembly on a Recombination Intermediate

Jessica M. Jones and Hiroshi Nakai*

Department of Biochemistry
and Molecular Biology
Georgetown University Medical
Center, 3900 Reservoir Rd
NW, Washington DC 20007
USA

PriA and other primosome assembly proteins of *Escherichia coli* recruit the major replicative helicase DnaB for replisome assembly during bacteriophage Mu transposition and replication. MuA transposase catalyzes the transfer of Mu ends to target DNA, forming a potential replication fork that provides the assembly site for the replisome. However, this fork lacks the single-stranded DNA needed to load DnaB. Although no pre-existing primosome assembly sites that bind PriA were found within the Mu end sequences, PriA was able to bind to the forked DNA structure created by MuA. The helicase activity of PriA could then open the duplex to create the DnaB binding site. In a tightly coupled reaction on synthetic forked substrates, PriA promoted both the unwinding of the lagging strand arm and preprimosome assembly to load DnaB onto the lagging strand template. PriA apparently translocated 3' to 5' along the lagging strand template until sufficient single-stranded DNA was exposed for binding of DnaB, which then translocated 5' to 3' in the opposite direction. Mutant PriA lacking helicase activity was unable to promote this process, and loss of PriA helicase impaired Mu DNA replication *in vivo* and *in vitro*. This suggests that the opening of the duplex by PriA helicase is a critical step in the initiation of Mu DNA replication. Concerted helicase and primosome assembly functions would allow PriA to act as initiator on recombination intermediates and stalled replication forks. As part of the replisome, PriA may act as a mobile initiator that minimizes interruptions in chromosomal replication.

© 1999 Academic Press

*Corresponding author

Keywords: *in vitro* DNA replication; phage Mu; PriA helicase; primosome

Introduction

Bacteriophage Mu DNA replication by transposition is a process intimately linked to non-homologous strand exchange catalyzed by MuA transposase. Monomeric MuA (Kuo *et al.*, 1991) binds to specific sites at the Mu ends (Craigie *et al.*, 1984), assembling into an active oligomeric transpososome bound to both Mu ends (Figure 1(a); Lavoie *et al.*, 1991; Mizuuchi *et al.*, 1992) aided by the host HU protein (Craigie *et al.*, 1985; Lavoie & Chaconas, 1993, 1994). Tetrameric MuA in the transpososome (Lavoie & Chaconas, 1990; Surette *et al.*, 1987) produces nicks at the Mu ends (Figure 1(b)) that are

transferred to target DNA (Craigie & Mizuuchi, 1985, 1987) bound with a second transposition protein MuB (Adzuma & Mizuuchi, 1988). The resulting product, strand transfer complex 1 (STC1; Figure 1(c)), includes a potential replication fork (the Mu fork) that can act as the initiation site for Mu DNA replication at each Mu end, with the 3'-OH ends of target DNA providing the primers for leading strand synthesis. However, access to these forks is restricted by oligomeric MuA which remains tightly bound to the Mu ends (Krukltis & Nakai, 1994).

In preparation for replisome assembly, MuA promotes the formation of a prereplisome at the Mu fork (Nakai & Krukltis, 1995). First, the molecular chaperone ClpX alters quaternary interactions of oligomeric MuA (Levchenko *et al.*, 1995) in STC1, forming an altered transpososome STC2 (Krukltis *et al.*, 1996). Additional host factors (Mu replication factor α_2 or MRF α_2) then displace MuA from STC2 to form a new nucleo-

Abbreviations used: STC, strand transfer complex; MRF, Mu replication factor; pol, polymerase; PAS, primosome assembly site; RF, replicative form; WT, wild-type.

E-mail address of the corresponding author:
nakai@bc.georgetown.edu

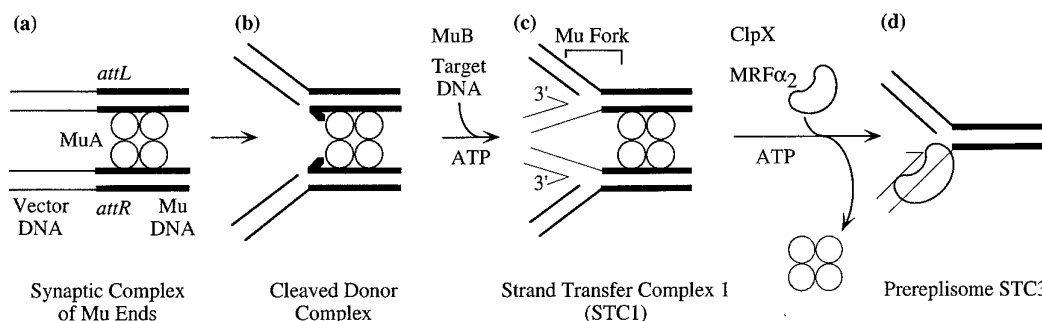

Figure 1. Formation of the transpososome and prereplisome during Mu transposition. (a) The transposase MuA binds to sites on the left (*attL*) and right (*attR*) ends of Mu (thick lines) forming a tetramer that brings the ends together in a synaptic complex. (b) The transpososome consisting of tetrameric MuA introduces a nick at each Mu end. (c) The resulting 3'-OH ends (half arrows) are transferred to target DNA (very thin lines) bound with MuB to form STC1, a complex which includes a potential replication fork (the Mu fork) at each Mu end. (d) Molecular chaperone ClpX changes the quaternary interactions within the MuA tetramer to form STC2 (not shown) and factors within the partially purified host fraction MRF α_2 displace MuA from STC2, disrupting the synaptic complex of Mu ends and forming the prereplisome STC3 (only one Mu end is shown).

protein complex STC3 (Figure 1(d)), a prereplisome that permits Mu DNA synthesis only by specific primosome components and the DNA polymerase (pol) III holoenzyme (Jones & Nakai, 1997; Krukltis *et al.*, 1996; Nakai & Krukltis, 1995).

The disassembly of the transpososome leads to the formation of a replisome that catalyzes semi-discontinuous DNA synthesis from one Mu end to the other to form the cointegrate replication product. Central to this process is the assembly of a preprimosome at the Mu fork using the proteins PriA, PriB, PriC, DnaT, DnaB, and DnaC (Jones & Nakai, 1997). Together with primase these proteins comprise the ϕ X174-type primosome, originally characterized as an apparatus that primes DNA synthesis on the single-stranded ϕ X174 template (Wickner & Hurwitz, 1974). After the major replicative helicase DnaB is loaded from the DnaB-DnaC complex onto the lagging strand template, DnaB can serve as the organizing center of the replisome, stably binding the dimeric DNA pol III holoenzyme to the leading strand primer (Yuzhakov *et al.*, 1996). DnaB translocates 5' to 3' along the lagging strand template to unwind the helix (LeBowitz & McMacken, 1986) and attracts primase for lagging strand synthesis (Tougo *et al.*, 1994).

PriA, PriB, PriC, and DnaT's function in promoting the binding of DnaB at the fork distinguishes the process from DnaB assembly at the bacterial origin *oriC* where the initiator protein DnaA plays this role (Funnell *et al.*, 1987). PriA and the other primosome components have been found to play an important function in the initiation of DnaA-independent DNA synthesis such as replication of pBR322 (Minden & Marians, 1985). PriA-deficient strains assimilate genetic markers poorly by homologous recombination and are defective in double-strand break repair as well as inducible and constitutive stable DNA replication (Kogoma *et al.*, 1996;

Masai *et al.*, 1994). Thus, PriA may couple homologous recombination to DNA replication by promoting replisome assembly at D-loop structures created by homologous strand exchange (Asai & Kogoma, 1994; Kogoma, 1996), a function that would also allow PriA to promote restart of DNA replication when replication forks stall.

PriA is the primosome component that initially binds to the DNA template. ϕ X174 DNA includes a single primosome assembly site (PAS), a sequence to which PriA binds (Arai & Kornberg, 1981; Shlomai & Kornberg, 1980a), and there are two PASs near the origin of pBR322 (Zipursky & Marians, 1980). PriA can also bind to branched DNA structures that resemble D-loops (McGlynn *et al.*, 1997). We have previously demonstrated that PriA promotes primosome-dependent Mu DNA replication on both the prereplisome STC3 and the strand transfer product deproteinized by extraction with phenol (Jones & Nakai, 1997). However, the potential replication fork created by strand transfer does not include single-stranded DNA on the lagging strand arm. This poses a problem for the loading of DnaB, which occupies 20 nt of single-stranded DNA on the lagging strand template (Bujalowski & Jezewska, 1995). The 3' to 5' helicase activity of PriA (Lasken & Kornberg, 1988; Lee & Marians, 1987) could potentially create the necessary duplex opening, analogous to DnaA opening the duplex at *oriC* to create a binding site for DnaB (Bramhill & Kornberg, 1988).

Here, we investigate the function of PriA helicase in Mu DNA replication, establishing a new role for PriA's helicase activity in catalyzing a critical step in initiation. While the PriA helicase activity is not needed for primosome assembly on single-stranded templates (Zavitz & Marians, 1992), we demonstrate that it can open the duplex for entry of DnaB when sufficient single-stranded DNA is not available.

Results

PriA helicase can catalyze a critical step in the initiation of Mu DNA replication

PriA is essential *in vivo* for Mu DNA replication by transposition. No phage growth and no measurable amplification of Mu DNA can be detected in a *priA1::kan* host (Jones & Nakai, 1997). We determined that the mutant PriA K230R protein, which is defective in 3' to 5' helicase activity (Zavitz & Mariani, 1992), was partially deficient in its ability to support Mu DNA replication. Mu plating efficiency was reduced by 50% on a PriA K230R host (data not shown), and PriA K230R promoted relatively slow rates of Mu DNA replication *in vivo*. AT3853 *priA1::kan*, a thermoinducible Mucts62 lysogen, was transformed with a plasmid expressing either PriA (pEL042; Lee & Kornberg, 1991) or PriA K230R (pEL042 K230R), and the lysogens were induced at mid-exponential phase (1.5×10^8 cells/ml). Phage development was monitored by quantitating amplification of Mu DNA relative to a host marker by Southern blot analysis and by scoring phage production. In the PriA K230R strain, Mu DNA was replicated at a reduced rate and was amplified to less than 30% the level attained in the PriA⁺ strain (Figure 2(a)). Under these growth conditions, release of phage particles from the PriA K230R strain was delayed 20-30 minutes with a burst size approximately 50% that of the PriA⁺ lysogen (Figure 2(b)). When cultures were diluted 20-fold at the start of induction, the difference in phage yield between the PriA⁺ and PriA K230R strains was decreased (Figure 2(c)). These results indicate that PriA helicase is required for optimal

rates of Mu replication *in vivo*, especially for phage growth at higher cell densities.

The strand transfer complex STC1 can be converted to a cointegrate *in vitro* in a system containing the ϕ X-type primosome components, DNA pol III holoenzyme, SSB, DNA gyrase, ClpX and the host fraction MRF α (Jones & Nakai, 1997). If PriA K230R replaced PriA in this system, cointegrate production would be reduced as much as 50-fold (Figure 3(a), cf. lanes 5 and 9). Other proteins present in a crude cell extract, however, could complement the helicase defect of PriA K230R. Both PriA and PriA K230R complemented an extract of AT3327 *priA1::kan* to promote high levels of cointegrate formation (Figure 3(b), lanes 3 and 4), consistent with our observation that phage growth can occur, albeit at a reduced rate, when PriA is defective for helicase activity. These results indicate that other host proteins can carry out the function performed by PriA helicase. How well they do so *in vivo* may be influenced by cell growth conditions such as cell density.

Both PriA and PriA K230R can bind to the forked DNA structure created by Mu strand transfer

Although PriA is needed to initiate Mu DNA replication, the type of PAS sequences that are on ϕ X174 DNA and pBR322 could not be found at the Mu ends. We searched for ϕ X-type PAS within the mini-Mu element of donor substrate pGG215 (Surette *et al.*, 1987; Figure 4(a)), which is readily converted to a cointegrate in the reconstituted Mu transposition and replication system. Denatured DNA fragments were assayed for their ability to

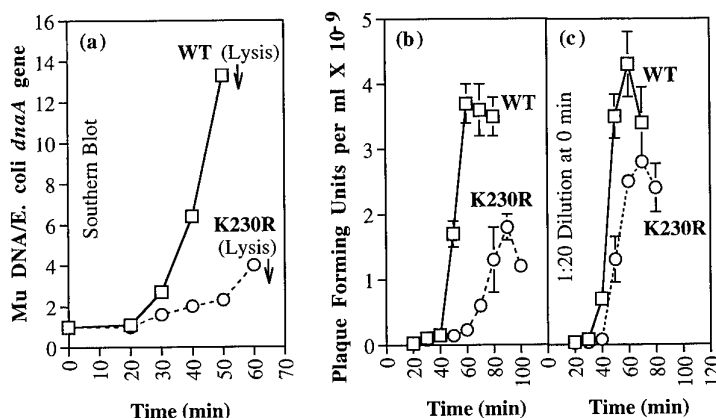

Figure 2. Deficiencies in Mu DNA replication supported by PriA K230R *in vivo*. (a) Mu DNA is amplified poorly during Mu lytic development in a PriA K230R strain (AT3853 *priA1::kan* pEL042 K230R) compared to a strain wild-type for PriA (AT3853 *priA1::kan* pEL042). A Southern blot of genomic DNA from samples collected at various points between induction (0 minute) and lysis was probed for Mu-specific and *E. coli*-specific (*dnaA* gene) sequences as described in Materials and Methods. The ratio of Mu signal/*E. coli dnaA* signal at 0 minute was set to 1. (b) and (c) Phage production is reduced in a PriA K230R strain but is improved by growth at lower cell density. Phage production was measured as described in Materials and Methods in cultures that were either left (b) undiluted or (c) diluted 20-fold at the point of induction (0 minute). Values are the average of three measurements with standard deviation of the mean shown by error bars.

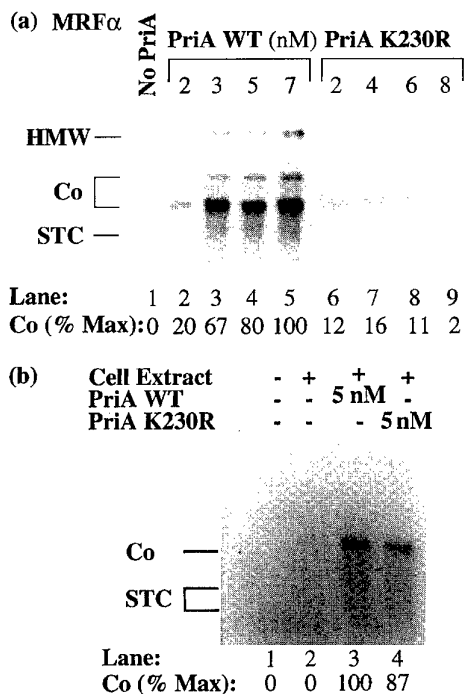

Figure 3. Differences between PriA and PriA K230R in their abilities to support Mu DNA replication *in vitro*. (a) PriA K230R lacks a function needed to initiate Mu DNA replication. Replication of STC1 in the reconstituted reaction system was conducted as described in Materials and Methods using PriA or PriA K230R as indicated. Autoradiographs of replication products are shown. In the most active reaction (lane 5) 90% of STC1 was converted to cointegrate (Co); this level was set to 100%. (b) The defective function of PriA K230R can be complemented by a crude cell extract (Fr II). Replication of STC1 supported by crude cell extract was conducted as described in Materials and Methods using PriA or PriA K230R as indicated. Autoradiographs of replication products linearized with *EcoRI* are shown. In the most active reaction (lane 3) >95% STC1 was converted to cointegrate; this level was set to 100%.

stimulate PriA's ATPase activity (Shlomai & Kornberg, 1980a,b; Zipursky & Marians, 1980), and the only PAS that were detected were the two present near the pBR322 origin (Figure 4(b), fragment D) located outside of the mini-Mu element. A donor substrate from which these two PAS were removed (pGG215 Δ PAS) was active in Mu transposition and replication, using target DNA that also contains no PAS (data not shown). These results indicate that ϕ X-type PAS are not required for Mu DNA replication.

PriA also binds to structures that resemble D-loops (McGlynn *et al.*, 1997), and this suggested that the PriA binding site may be created as the Mu ends are transferred to target DNA to form a branched DNA structure. In support of this hypothesis, band shift assays indicated that PriA binds to synthetic forked oligonucleotide substrates that mimic the DNA structure of the strand transfer product. A forked substrate containing the Mu right-end sequence was assembled from four oligonucleotides (Substrate A, Figure 5(a)). The duplex ahead of the fork consisted of 50 bp of Mu right end sequence with leading and lagging strand arms of 40 and 28 nt, respectively. As in the Mu strand transfer product, the fork is fully duplex except for a five-base gap between the leading strand primer and the fork. PriA was able to produce a discrete mobility shift with Substrate A (Figure 5(b), lanes 4-6), whereas it was unable to do so with the corresponding linear oligonucleotide that contains the Mu right-end (Substrate Z; Figure 5(b), lanes 1-3).

In addition, the deficiency of PriA K230R in promoting Mu DNA replication is not due to any defect in binding the Mu fork. PriA and PriA K230R bound to Substrate A (Figure 5(c)) with dissociation constants (K_D) of 21 and 19 nM, respectively, comparable to the K_D of 11 nM for binding PriA to the ϕ X174 PAS (Ng & Marians, 1996a).

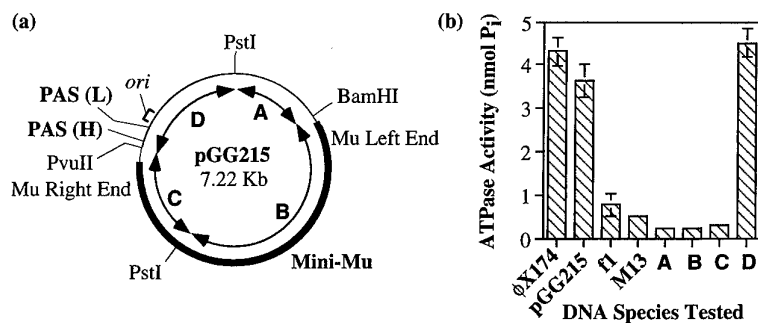

Figure 4. The Mu left and right ends do not contain PAS. (a) pGG215 donor substrate. The mini-Mu element is indicated in bold; the Mu left and right ends are on fragments B and C, respectively. The two pBR322 PAS (designated L and H; Zipursky & Marians, 1981) in the pGG215 vector are on fragment D. (b) Fragments that include regions of mini-Mu do not stimulate PriA's ATPase activity. Fragments A-D of pGG215 (subcloned into M13mp18) and full-length pGG215 were assayed for the ability to stimulate PriA's ATPase activity as described in Materials and Methods. Results are the average of three independent trials with standard deviation given by error bars.

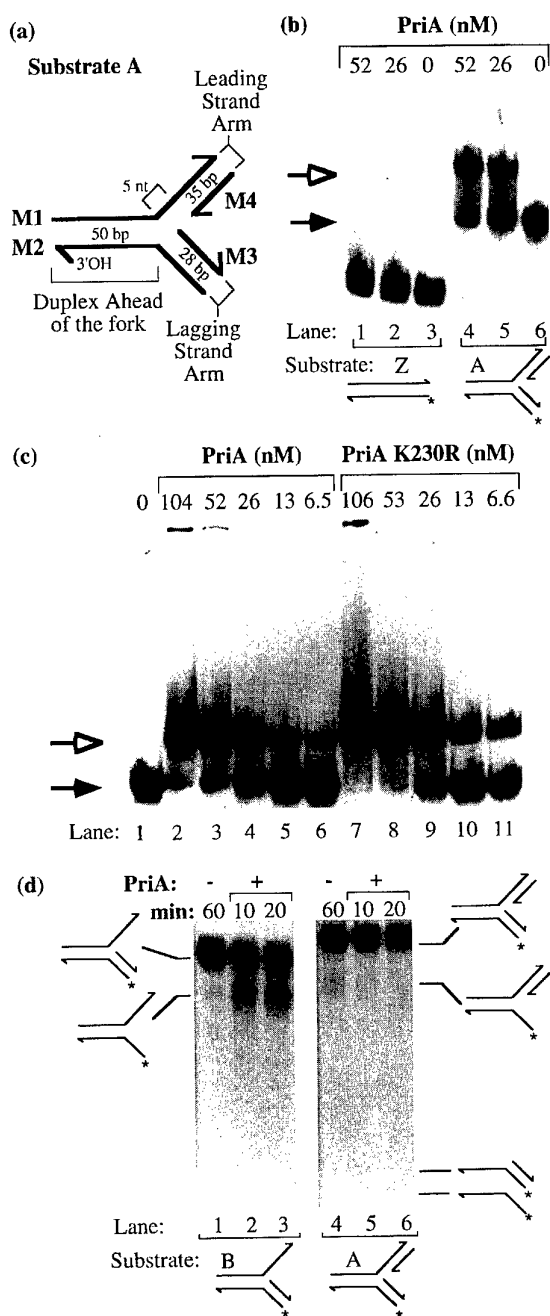

Figure 5. Ability of PriA to bind and unwind synthetic substrates resembling the Mu fork. (a) Substrate A (oligonucleotides M1, M2, M3, and M4). This substrate reflects the Mu fork DNA structure, with a five nucleotide (nt) opening present on the leading strand arm and a completely duplex lagging strand arm. (b) PriA binds to Substrate A but not to Substrate Z (oligonucleotides M2 and M5) in band shift assays. Lane shifts were conducted as described in Materials and Methods. The filled arrow indicates the position of free Substrate A; the open arrow indicates the position of the shifted complex. (c) PriA and PriA K230R bind equally well to substrate A in band shift assays. (d) PriA unwinds Substrate B (oligonucleotides M1, M2 and M3) more efficiently than Substrate A in helicase assays. Helicase assays that included PriA and SSB were conducted as described in Materials and Methods.

Unwinding of the lagging strand arm of a synthetic fork by PriA helicase











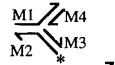



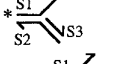

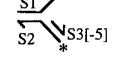







The role of PriA helicase in Mu DNA replication suggested that it may expose single-stranded DNA on the lagging strand side of a fork to load DnaB helicase. We investigated whether PriA could promote duplex opening at a fork as it promotes preprimosome assembly. Because PriA does not promote DNA synthesis as efficiently on the deproteinized strand transfer product as on the preprimosome STC3 (Jones & Nakai, 1997), naked DNA substrates with the exact structure of the Mu fork might not necessarily be the best substrates for PriA helicase. For this analysis we searched for suitable forked oligonucleotide structures that would serve as good substrates for PriA helicase but have insufficient single-stranded DNA to load DnaB onto the lagging strand template.

PriA helicase was more active on substrates with a single-stranded leading strand arm than on substrates with two duplex arms such as the Mu fork. Although PriA bound to both Substrate A (the Mu fork) and Substrate B (the analogous fork with single-stranded DNA on the leading strand arm) with nearly equal affinity (data not shown), its helicase was five times more active on Substrate B than on Substrate A (Figure 5(d), cf. lanes 1-3 with lanes 4-6; Table 1, lines 1 and 2). In the presence of SSB, the lagging strand arm (M2-M3 duplex) of Substrate B was unwound almost exclusively, most likely the result of PriA binding to the lagging strand template at the fork and translocating in a 3' to 5' direction.

A small gap may also facilitate access of PriA to the lagging strand template. PriA had little helicase activity on Substrate C (Table 1, line 3), a fork analogous to Substrate B but with a longer lagging strand arm and a different DNA sequence. Helicase action on Substrate C was comparable to that on Substrate B when a five-base gap was introduced on the lagging strand arm (Substrate C[-5], Table 1, line 4). A gap of three nucleotides was sufficient to promote helicase action, whereas a gap of a single nucleotide was not (data not shown). PriA bound equally well to Substrates C and C[-5] (data not shown), indicating that reduced helicase activity on Substrate C was not due to reduced binding affinity. Substrate C has a lagging strand arm (S2-S3 duplex) of 70 nt compared to 28 nt for Substrate B; in addition, it does not have Mu end sequences in the 30 bp duplex ahead of the fork (S1-S2 duplex). Although Substrate B has no single-stranded segment on the lagging strand template, some feature of Substrate B, such as the shorter length of the lagging strand or its DNA sequence, may permit exposure of single-stranded DNA on the lagging strand template, allowing PriA to initiate unwinding. The requirement of the gap in Substrate C for PriA helicase activity was not examined further at this time.

Our overall results indicated that Substrate C[-5] was an ideal substrate for examining the

Table 1. PriA, DnaB, and preprimosome helicase activity on synthetic DNA fork substrates

Substrate	Proteins present	Total substrates consumed	Labeled products
1) A 	PriA, SSB	5%	 3%  2%
2) B 	PriA, SSB	25%	 25%
3) C 	PriA, SSB	3%	 3%
4) C[-5] 	PriA, SSB	27%	 24%  3%
5) C[-5]	PriA, PriB, PriC, DnaT, DnaBC, SSB	50%	 21%  4%  25%
6) C[-5]	PriA, PriB, PriC, DnaT, SSB	43%	 39%  1%  2%
7) C[-5]	PriB, PriC, DnaT, DnaBC, SSB	3%	 2%  1%
8) C[-5]	PriA, DnaBC, SSB	38%	 35%  1%  2%
9) C[-5]	DnaBC, SSB	3%	 3%
10) D 	DnaBC, SSB	31%	 31%
11) D	PriA, PriB, PriC, DnaT, DnaBC, SSB	40%	 40%

Helicase assays using the components indicated were performed as described in Materials and Methods. Oligonucleotide composition of each substrate is shown; the oligonucleotide designated with an asterisk is radiolabeled. Major products (>20% of total substrate) are highlighted in bold; any potential products not listed represent <1% total substrate. Less than 1% of substrate was consumed in control reactions including only SSB.

role of PriA helicase during preprimosome assembly. The gap of five nucleotides and the single-stranded leading strand arm allowed preferential PriA helicase action on the lagging strand arm in the presence of SSB (Table 1, line 4), but the gap is too small to provide a binding site for DnaB (Bujalowski & Jezewska, 1995; Table 1, line 9). If DnaB is bound to the lagging strand arm of Substrate C[-5], its single-stranded leading strand arm would also allow efficient unwinding of the duplex ahead of the fork by DnaB. When DnaB unwinds DNA in the absence of DNA pol III holoenzyme, a 3' single-stranded tail is required on the DNA strand to be displaced (LeBowitz & McMacken, 1986) even when DnaB is acting as part of the preprimosome (Lee & Marians, 1989).

Duplex opening by PriA can promote loading of DnaB onto the fork during preprimosome assembly

The preprimosome (PriA, PriB, PriC, DnaT, and DnaBC) in the presence of SSB efficiently unwound the duplex ahead of the fork on Substrate C[-5]

(S1-S2 duplex; 29% of the total substrate; Table 1, line 5). The major product of this process was single-stranded S2 (25% of total substrate), a result of unwinding both the S1-S2 and S2-S3 duplexes. When DnaB was omitted from the reaction mixture (Table 1, line 6), very little of the S1-S2 duplex was unwound, although the S2-S3 duplex was still unwound at high levels. Very little of the substrate was unwound at all if PriA was omitted from the reaction mixture (Table 1, line 7). These results are consistent with a mechanism in which PriA unwinds the lagging strand arm to promote unwinding of the duplex ahead of the fork by DnaB.

Preprimosome assembly was required for unwinding the S1-S2 duplex in this reaction. When PriB, PriC and DnaT were omitted, only the lagging strand arm could be unwound at high levels (Table 1, line 8). PriB, PriC, and DnaT bring PriA and DnaB together in a single complex (Liu *et al.*, 1996; Ng & Marians, 1996a,b). In contrast, PriABC and DnaT were not required for DnaB helicase action if the lagging strand arm of the fork was single-stranded. Substrate D, which has two single-

stranded arms, was unwound in the presence of DnaBC without the remaining preprimosome components (Table 1, cf. lines 10 and 11), provided that DnaB was allowed to bind to the substrate before the addition of SSB (data not shown).

We confirmed that PriA helicase activity was essential for unwinding of the S1-S2 duplex of Substrate C[-5] by the preprimosome; little or no unwinding could be detected when PriA K230R replaced PriA (Figure 6(a)). In addition, we were able to distinguish participation of the two helicases by taking advantage of their different nucleotide requirements when ATP is not the major energy source (Lasken & Kornberg, 1988; LeBowitz & McMacken, 1986; Lee & Marians, 1987, 1989). Unwinding of the S1-S2 duplex of Substrate C[-5] by the preprimosome components required both dATP and GTP to support the PriA and DnaB helicases, respectively, as well as low levels of ATP

($\leq 10 \mu\text{M}$; Figure 6(b)). By itself this ATP concentration is insufficient to fuel S1-S2 duplex unwinding on Substrate C[-5] (Figure 6(b)), but it probably plays a role in assembly or activation of the preprimosome to elicit its two helicase activities (Lee & Marians, 1989). In the absence of dATP needed to drive PriA helicase action, unwinding of the substrate was very low (Figure 6(b)), consistent with the inability of PriA K230R to promote unwinding of the S1-S2 duplex. In the absence of GTP, the S2-S3 duplex was unwound (data not shown), confirming that PriA could be driven by dATP, but only very low levels of S1-S2 duplex unwinding were observed (Figure 6(b)). In contrast, unwinding of Substrate D, which has two single-stranded arms, could be fueled by GTP alone (data not shown), consistent with the ability of DnaB to unwind this fork. These results demonstrate that both the 3' to 5' helicase of PriA and the 5' to 3' helicase of DnaB are needed to unwind the S1-S2 duplex on Substrate C[-5] and that this process requires preprimosome assembly to promote the concerted action of the two helicases. This strongly suggests that unwinding of the S2-S3 duplex and the loading of DnaB onto the fork are coupled events.

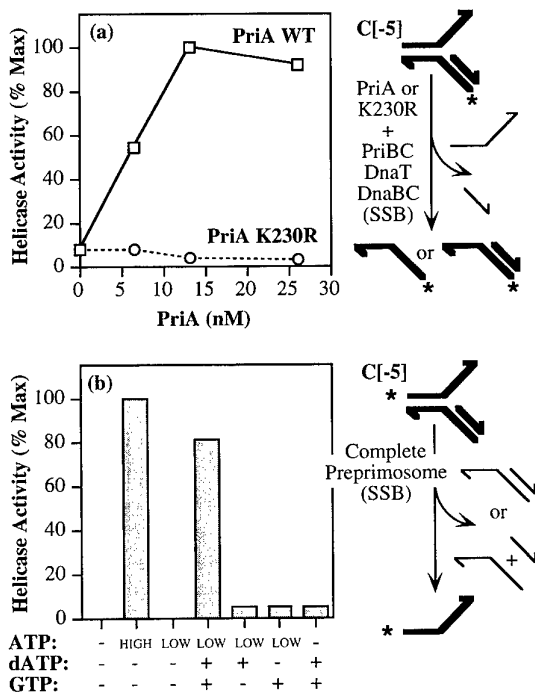

Figure 6. Contribution of the two preprimosomal helicases in unwinding forked substrates. (a) PriA K230R does not support unwinding of the S1-S2 duplex on Substrate C[-5] by the preprimosome. Helicase assays that included PriA or PriA K230R as well as PriB, PriC, DnaT, DnaBC and SSB were performed as described in Materials and Methods. Total unwinding of the S1-S2 duplex was measured. The level in the most active reaction (13 nM PriA WT) was set to 100%. (b) Nucleotide requirements for unwinding of the S1-S2 duplex in Substrate C[-5] by the preprimosome. Helicase assays that included PriA, PriB, PriC, DnaT, DnaBC and SSB were supplemented with ATP (2 mM [HIGH] or 10 μM [LOW]), dATP (2 mM) and GTP (3.4 mM) as indicated. Production of S2 in the most active reaction (2 mM ATP) was set to 100%. Results are the average of two independent trials; duplicate values varied by less than 5%.

Duplex opening by PriA is coupled to loading of DnaB during preprimosome assembly

We confirmed that unwinding of the S2-S3 and S1-S2 duplexes of Substrate C[-5] by the preprimosome is tightly coupled using a competition experiment. The preprimosome components were first allowed to associate with this substrate at 0°C, conditions that do not allow any helicase action (data not shown). Even after subsequent challenge with 100-fold excess competitor DNA (the single-stranded oligonucleotide M5), both duplexes were still unwound to form the single-stranded S2 product (Figure 7(a), open triangles). This level of competitor effectively inhibited action of PriA or the preprimosomal helicases if these proteins were not first allowed to associate with the substrate (Figure 7(a) and (b), filled symbols). Moreover, the DnaB helicase activity on Substrate D, which could be produced from Substrate C[-5] by the action of PriA, was effectively inhibited by the competitor even when the substrate was first incubated together with DnaBC (Figure 7(c)). These results indicate that when the preprimosome components unwind the S2-S3 duplex of Substrate C[-5], they promote binding of DnaB before running off the template, coupling the processes of duplex opening and preprimosome assembly.

Discussion

Role of PriA helicase in duplex opening and replisome assembly at the Mu fork

A universal step in the initiation of DNA replication is the opening of the DNA duplex to promote

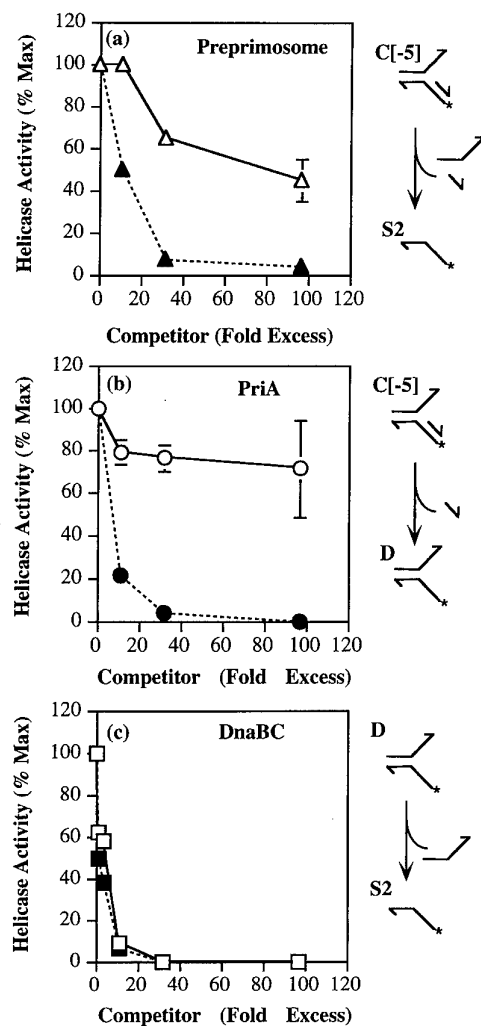

Figure 7. Duplex opening by PriA is tightly coupled to loading of DnaB onto forked substrates. Preprimosome components were initially incubated with substrate for ten minutes on ice before the addition of competitor DNA (the single-stranded oligonucleotide M5) and SSB followed by a 15 minute incubation at 30°C (open symbols); alternatively, competitor DNA was present during the ten minute incubation on ice (filled symbols). Values are the average of multiple independent trials with standard deviation of the mean provided by error bars. (a) The preprimosome unwinds the two duplexes of Substrate C[-5] in the presence of excess competitor. Helicase assays included preprimosomal components PriA, PriB, PriC, DnaT, and DnaBC. Production of S2 in the absence of competitor was set to 100%. (b) PriA unwinds the S2-S3 duplex of Substrate C[-5] in the presence of excess competitor. Helicase assays included the preprimosomal component PriA. The accumulation of Substrate D product was quantitated. Production of Substrate D in the absence of competitor was set to 100%. (c) Helicase activity of DnaB on Substrate D is inhibited by challenge with competitor. Helicase assays included the preprimosomal component DnaBC complex. Production of S2 in the absence of competitor was set to 100%.

binding of the major helicase DnaB, a process that ultimately leads to the assembly of the replisome. For bacterial chromosomal replication the DnaB protein serves the function of opening the duplex (Bramhill & Kornberg, 1988) and recruiting DnaB helicase to form the prepriming complex at *oriC* (Baker *et al.*, 1986; Funnell *et al.*, 1987). For initiation of Mu DNA replication by transposition, assembly proteins PriA, PriB, PriC, and DnaT of the ϕ X-type primosome are involved in recruiting DnaB to the initiation site (Jones & Nakai, 1997). On synthetic DNA forks that have insufficient single-stranded DNA on the lagging strand arm to bind DnaB (as is the case with the Mu fork), the PriA helicase unwinds this duplex arm while promoting preprimosome assembly and binding of DnaB to DNA. Mu DNA replication *in vivo* proceeds at less than optimal rates when the PriA helicase is inactive, and PriA helicase is required for significant levels of Mu DNA replication *in vitro* in the reconstituted system, indicating that the PriA helicase can catalyze a critical step in initiation of Mu DNA replication. These results are consistent with a mechanism where PriA opens the duplex at the Mu fork to create a binding site for DnaB.

Our results indicate that during preprimosome assembly at a fork, DnaB binds to the same strand as PriA. The bidirectional helicase activity of the preprimosome was first demonstrated by assembling the complex on the phage ϕ X174 PAS (Lee & Marians, 1989). However, the opposing helicase activities of PriA and DnaB raises the possibility that PriA at a replication fork might normally translocate 3' to 5' along the leading strand template, augmenting DnaB's progress on the lagging strand template. The role of PriA helicase at the Mu fork illustrates the utility of coupling two helicases moving in opposite directions on the same strand.

It is not yet clear how PriA would initiate helicase action on the Mu strand transfer product. Forked oligonucleotide substrates with the structure of the Mu fork are generally not good substrates for PriA helicase (e.g. Table 1, line 1). This is consistent with the observation that the preprimosome and DNA pol III holoenzyme initiate DNA replication less efficiently on the deproteinized strand transfer product than on the prereplisome STC3 (Jones & Nakai, 1997). There is also the problem of directing PriA to translocate along the lagging strand template rather than the leading strand template so that DnaB is loaded onto the correct strand. One possibility is that the prereplisome proteins (MRF α_2) in STC3 promote PriA helicase action on the lagging strand arm of the fork. After completion of strand transfer, the transpososome is displaced by the prereplisome proteins with the aid of the molecular chaperone ClpX (Krukltis & Nakai, 1994; Krukltis *et al.*, 1996), and these proteins allow Mu DNA replication to proceed only by a PriA-dependent pathway.

In our current model for initiation at the Mu fork (Figure 8), PriA plays the function analogous

to that of DnaA at *oriC* by recognizing the initiation site created by strand transfer and opening the duplex for replisome assembly. We speculate that the prereplisome proteins present in STC3 (Figure 8(a)), while not required for PriA binding, may direct PriA to the lagging strand arm of the Mu fork. The binding of PriA to the Mu fork (Figure 8(b)) promotes recruitment of the other prereplisome proteins (Figure 8(c) and (d)). Initiation of PriA helicase action unwinds the lagging strand arm of the fork (Figure 8(d)), and once enough single-stranded DNA is exposed, DnaC dissociates from DnaB allowing DnaB to bind to the DNA (Funnell *et al.*, 1987; Learn *et al.*, 1997; Wahle *et al.*, 1989a,b). PriA and DnaB may then translocate in opposite directions on the lagging strand template (Figure 8(e)). However, the 3' to 5' helicase activity of the prereplisome requires significantly higher NTP concentrations than the 5' to 3' helicase activity (Lee & Marians, 1989), a property that may eventually cause PriA to disengage from the lagging strand template. Once DnaB is bound to the lagging strand template, DNA pol III holoenzyme can then assemble at the fork through its inter-

action with the primer-template and with DnaB (Yuzhakov *et al.*, 1996; Figure 8(f)), completing the assembly of the replisome. If PriA is defective in helicase activity, other helicases or a 5' to 3' nuclease could create a single-stranded segment on the lagging strand template for DnaB loading. But in such a mechanism, the process of duplex opening and DnaB loading would not be so tightly coupled, and the rate at which DNA replication is initiated may be relatively slow.

General function of the prereplisome and its two helicases in the replication of the host chromosome

A major question regarding the PriA helicase has been its function in cellular DNA replication and recombination and its relationship to PriA's role in primosome assembly. Knock-out mutations of the *priA* gene are not lethal but have serious consequences including slow growth, poor viability, sensitivity to DNA damaging agents, and characteristics of a constantly induced SOS response (Lee & Kornberg, 1991; Nurse *et al.*, 1991).

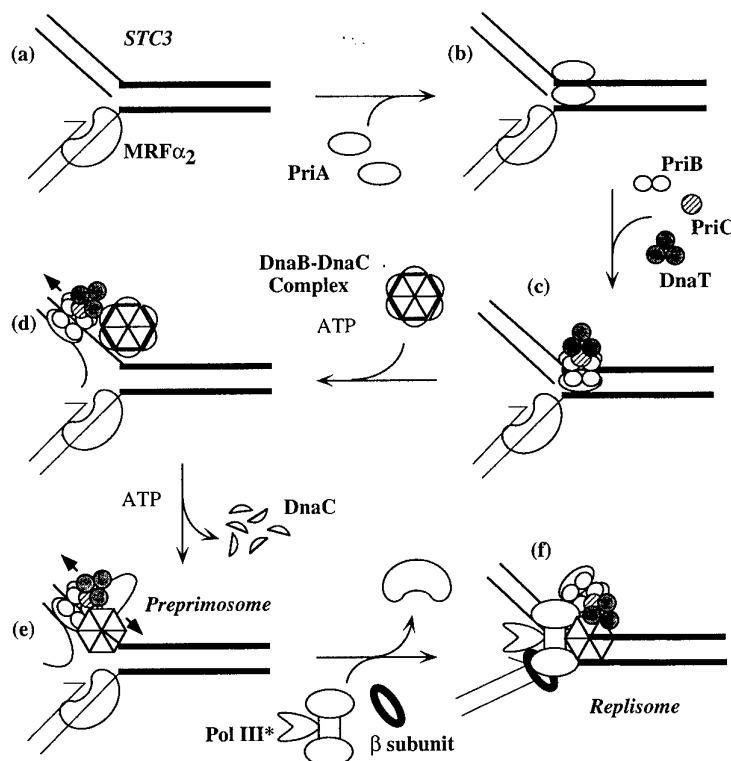

Figure 8. Model for PriA helicase-assisted assembly of the replisome during Mu transposition. (a) The prereplisome STC3 includes host protein components ($MRF\alpha_2$) which protect the leading strand primer. (b) PriA binds to the lagging strand template at the fork. (c) PriB, PriC and DnaT enter the PriA-DNA complex. (d) The DnaB-DnaC complex associates with the PriABC-DnaT complex, and the 3' to 5' helicase of PriA unwinds the lagging strand arm to create a binding site for DnaB. (e) With the exit of DnaC from the complex, DnaB is loaded onto the lagging strand completing assembly of the prereplisome. The opposing 3' to 5' and 5' to 3' helicase activities of the prereplisome could form a single-stranded loop on the template. (f) The association of DNA pol III holoenzyme with the leading strand primer-template and DnaB completes assembly of the replisome, with the hypothetical exit of $MRF\alpha_2$. PriA may eventually dissociate from the lagging strand template to terminate action of the 3' to 5' helicase.

Expression of PriA that is defective in helicase activity can restore the wild-type phenotype in essentially all respects (Zavitz & Marians, 1992), and helicase-deficient PriA proteins such as PriA K230R are fully active in promoting primosome assembly on the ϕ X174 template (Zavitz & Marians, 1992). These data suggest that the primosome assembly function, but not the helicase function, plays a critical role in the replication and maintenance of the chromosome. Nevertheless, helicase mutants do not necessarily restore full transformation efficiency of pBR322-based plasmids (Zavitz & Marians, 1992) or full efficiency in inheritance of genetic markers by P1 transduction (Sandler *et al.*, 1996). PriA helicase could accelerate the rate at which DnaB is loaded by expanding the duplex opening when insufficient single-stranded DNA is available.

It has been suggested that PriA together with proteins that promote homologous recombination may function in reassembly of the replisome when a replication fork stalls at a lesion or interruption in the template (Asai *et al.*, 1994; Bierne & Michel, 1994; Courcelle *et al.*, 1997; Kogoma, 1997; Kuzminov, 1995; Nurse *et al.*, 1991; Rupp & Howard-Flanders, 1968; Zavitz & Marians, 1992). We have found that the preprimosome readily assembles on a forked substrate with a single-stranded leading strand arm, and such a substrate could result if DNA polymerase encounters a blockage on the leading strand template. If lagging strand synthesis continues uncoupled from leading strand synthesis, a single-stranded gap on the leading strand template would be created. Formation of such a product has been observed when DNA replication was reconstituted with eukaryotic cell extract on templates that have thymine dimers (Svoboda & Vos, 1995). Such single-stranded gaps created by DNA replication are thought to provide the SOS-inducing signal in *Escherichia coli* (Sassanfar & Roberts, 1990). On the resulting stalled fork, there may not be sufficient single-stranded DNA available on the lagging strand arm to allow restart of replication. While a nuclease or other helicase could potentially expose a region of single-stranded DNA, the most efficient method of creating the duplex opening is to couple PriA helicase action with preprimosome assembly.

The ability of PriA to bind to forked structures, open the duplex and promote primosome and replisome assembly is similar to the function carried out by the initiator DnaA at *oriC*. The major difference is that the signal to initiate replication for PriA is the DNA structure found at stalled forks and recombination intermediates. Once assembled, the protein composition of the preprimosome is conserved as the replisome translocates along the DNA template (Ng & Marians, 1996b). PriA in the replisome may facilitate restart of replication if the replisome encounters lesions or breaks in the DNA. PriA's ability to translocate in a direction opposite to DnaB may promote reopening of the duplex to reassemble the replisome as well as

prevent disassembly of the preprimosome by allowing it to back off from the DNA lesion. While it is the task of DnaA to coordinate chromosomal replication with the cell cycle, the fully functional ϕ X-type primosome would act as a mobile initiator that helps keep interruptions in the progression of the replication fork to a minimum.

Materials and Methods

Plasmids and bacterial strains

pND706-PriA was a gift from Nick Dixon (Australian National University); pND706-PriA K230R (described below) was used to overproduce PriA K230R. pEL042 (Lee *et al.*, 1990) was a gift from Elliott Crooke (Georgetown University); this plasmid expresses PriA from its own promoter. To construct pND706-PriA K230R and pEL042 K230R, a single base substitution (A to G) at position 752 in the *priA* gene (Lee *et al.*, 1990) was introduced into both plasmids using the QuickChange[®] Site-Directed Mutagenesis Kit (Stratagene[®]) according to manufacturer's instructions. The mutagenized plasmids were sequenced by Veritas, Inc. (Rockville MD).

AT3327 and AT3327 *priA1::kan* have been described (Jones & Nakai, 1997). To construct AT3853 *priA1::kan*, the *priA1::kan* mutation (Lee & Kornberg, 1991) was introduced into AT3853 (Mucts62) by P1 transduction. Both *priA1::kan* strains were maintained on minimal media (Masai *et al.*, 1994) supplemented with 0.2% (w/v) Casamino acids and 25 μ g/ml kanamycin. Following CaCl_2 transformation (Sambrook *et al.*, 1989) with pEL042 or pEL042 K230R, strains were routinely grown on LB (Sambrook *et al.*, 1989) supplemented with 50 μ g/ml ampicillin.

Mu growth *in vivo*

Plating efficiency on AT3327 *priA1::kan* transformed with either pEL042 or pEL042 K230R was determined as described (Jones & Nakai, 1997); results represent four independent trials. To examine the kinetics of phage production and Mu DNA amplification, 200 ml cultures of AT3853 *priA1::kan* transformed with either pEL042 or pEL042 K230R were grown to an A_{600} of 0.4 (1.5×10^8 cells/ml) at 30°C, adjusted to a final concentration of 5 mM MgSO_4 and 0.2% (w/v) glucose, and then induced at 42°C for 90 minutes. In some cases cultures were diluted 20-fold at the start of induction (0 minute). Phage production at various times postinduction was measured by plating dilutions of the cultures in duplicate with indicator bacteria (AT3327). Alternatively, genomic DNA from sampled cultures was subjected to Southern blot analysis, performed and quantitated as described (Jones & Nakai, 1997).

Proteins

All restriction enzymes, DNA pol I, *E. coli* DNA ligase, and T4 polynucleotide kinase were purchased from New England BioLabs. Purification of PriA K230R was essentially as described for PriA by Marians (1995) with the exception that a Sephacryl[®] S-200 HR HiPrep[®] 16/60 column (Amersham Pharmacia Biotech) was used for preparation of Fr IV. Concentrations of PriA and PriA K230R were determined by the method described by Pace *et al.* (1995). All other proteins, crude cell extract

(Fr II), and MRF α (Fr III) were prepared as described (Jones & Nakai, 1997).

Reconstituted Mu DNA replication assay

Replication of STC1 (50 fmol as complex) was carried out with 55 fmol DNA pol III*, 190 fmol (as monomer) DNA pol III β subunit, 1.2 pmol DnaG (as monomer), 130 fmol DnaBC complex (DnaB₆-6DnaC), 15 pmol SSB (as tetramer), 900 fmol gyrase (as gyrA-gyrB dimer), 8.4 pmol ClpX (as monomer), 900 fmol ClpP (as tetradecamer), 0.01 unit of DNA pol I, 1 unit *E. coli* DNA Ligase, 60 fmol PriB (as dimer), 130 fmol PriC (as monomer), 470 fmol DnaT (as trimer), PriA or PriA K230R as indicated, and crude cell extract (12 units) or MRF α (12 units) in a 50 μ l reaction mixture as described (Jones & Nakai, 1997). Replication products were deproteinized and separated on 0.6% agarose gels in alkaline electrophoresis buffer (Sambrook *et al.*, 1989). Gels were neutralized and stained with 0.5 μ g/ml ethidium bromide and then dried and subjected to phosphorimager and autoradiography.

PriA ATPase assay

Fragments of pGG215 (Figure 4(a)) were subcloned into M13mp18 (Gibco BRL Life Technologies®), and replicative form (RF) DNA from these clones as well as ϕ X174 RF, M13mp18 RF, f1 RF and pGG215 were used in PriA ATPase assays. Linear, double-stranded DNA was heated to 100°C for ten minutes, then quickly cooled in an ice water-bath for five minutes prior to addition to the assay. The assay (15 μ l total volume) was conducted in 50 mM Hepes-KOH (pH 8.0), 10 mM MgOAc, 1 mM DTT, 100 mM potassium glutamate, 0.1 mg/ml bovine serum albumin, 10 μ g/ml rifampicin, 0.7 mM [γ -³²P]ATP (DuPont NEN®) plus 2 fmol (as duplex linear molecule) DNA, 170 fmol PriA (as monomer) and 15 pmol SSB (as tetramer). Reactions were incubated for 60 minutes at 37°C, then stopped by the addition of 3 μ l of 200 mM EDTA. A portion of each reaction (3 μ l) was spotted on a PEI-cellulose thin layer chromatography plate (J.T. Baker) which was developed in 0.5 M LiCl, 4.6% (v/v) formic acid, dried and subjected to phosphorimager. Generation of free ³²P phosphate was quantitated.

DNA substrates for band shift and helicase assays

Synthetic DNA substrates were constructed from the following oligonucleotides (Gibco BRL Life Technologies®): S1-CCATTAGCAAGGCCGAAACGTCACC AATGCAACGATCAGCCAACTAACTAGGACATCT-TTGCCACCA; S2-CGCTACAGTCTGACGCTAA-AGGCAAACCTTGATTCTGTGCTACTGATTACGG TGCTGCTATCGATGGTTTCATTGGTGACGTTTC-CGGCCTTGCTAATGG; S3-AAACCATCGATAG-CAGCACCGTAATCAGTAGCGACAGAATCAAG-TTTGCCTTTAGCGTCAGACTGTAGCG; S3[-5]-ATCGATAGCAGCACCGTAATCAGTAGCGACA-GAATCAAGTTTGCTTTAGCGTCAGACTGTAGCG; M1-GTTTTTCGCATTTATCGTGAAACGCTTTTCGCG-TTTTTCGTCGCCGCTTCATGTACACCGTTCATCT-TCTCTCGTTCAAAGTTGGTCAGTT; M2-AAGCT-GTGGTGGTAACAAGTAGTGCCGGTGAAGCG GCGC-ACGAAAAACGCGAAAGCGTTTCACGATAAATGC-GAAAAC; M3-CCGGCACTACTTGTACCACCA-CAGCTT; M4-AACTGACCAACTTTGAACGAGGAC-

AGATGAACGGT; M5-GTTTTTCGCATTTATCGT-GAAACGCTTTTCGCGTTTTTCGTCGCCGCTTCAC-CGGCACTACTTGTACCACCAAGCTT. The oligonucleotide composition of each substrate is provided in appropriate Figure legends and Table 1. For each substrate, one oligonucleotide was radiolabeled with ³²P to a specific activity of 2 \times 10⁶ to 5 \times 10⁶ CPM/pmol using T4 polynucleotide kinase. This oligonucleotide (10 pmol) was combined with two- to fourfold excess of various unlabeled oligonucleotides in 50 mM Tris-HCl (pH 7.5), 10 mM MgCl₂, 0.5 M NaCl, and the mixture was heated to 90°C then slowly cooled to 40°C. Annealed complexes were separated on 10% polyacrylamide gels (cross-linked at a ratio of 30:1) in TBE buffer (Sambrook *et al.*, 1989), and purified using the Elutrap® system (Schleicher & Schuell). The oligonucleotide composition of various substrates was confirmed by labeling all oligonucleotides in the purified substrate and separating them on a denaturing polyacrylamide gel.

Band shift assay

Band shifts were conducted essentially as described by McGlynn *et al.* (1997) using DNA substrates (16 fmol) and PriA or PriA K230R (0.13-1.1 pmol as monomer) in 20 μ l reaction mixtures. Band shift gels were dried and subjected to phosphorimager and autoradiography. The K_D value was determined as described by Ausubel *et al.* (1992) using the data shown in Figure 5(c).

Helicase assay

DNA substrates (16 fmol) were combined in 20 mM Tris-HCl (pH 7.5), 5.4 mM MgCl₂, 1 mM DTT, 0.1 mg/ml bovine serum albumin, and 2 mM ATP unless otherwise indicated (20 μ l total volume) with the following proteins as indicated: 260 fmol PriA or PriA K230R (as monomer), 60 fmol PriB (as dimer), 2.2 pmol PriC (as monomer), 2.4 pmol DnaT (as trimer), 500 fmol DnaBC complex, and 240 fmol SSB (as tetramer). Reaction mixtures excluding SSB were incubated on ice for ten minutes. SSB was then added and reactions were incubated for 15 minutes (unless otherwise indicated) at 30°C. Deproteinized products were separated on 10% polyacrylamide gels (cross-linked at a ratio of 30:1) in TBE buffer (Sambrook *et al.*, 1989) at 140 V for 2.5 hours. Gels were dried and subjected to phosphorimager and autoradiography. All experiments included a negative control, a reaction mixture to which only SSB was added (e.g. Figure 5(d), lane 1), and markers representing potential helicase products. The percent of total substrate converted to each product was calculated.

Other

All quantitation was by phosphorimager using the Molecular Dynamics Storm 840 system and ImageQuant® 1.11 B15 software.

Acknowledgments

Supplies of *E. coli* replication proteins for this study have been maintained as a collaboration with Nick Dixon (Australian National University), Kirsten Skarstad (Norwegian Radium Hospital) and Elliott Croke (Georgetown University). We also thank E. Croke, Sam Rab-

kin, Sadananda Rai and Ivan Zaloujnyi for their critical reading of the manuscript. This investigation was supported by a grant to H.N. from the National Institutes of Health (R01 GM49649). J.M.J. is supported by a pre-doctoral training grant from the Department of Defense Breast Cancer Research Program (DAMD17-98-1-8090).

References

- Adzuma, K. & Mizuuchi, K. (1988). Target immunity of Mu transposition reflects a differential distribution of Mu B protein. *Cell*, **53**, 257-266.
- Arai, K. & Kornberg, A. (1981). Unique primed start of phage ϕ X174 DNA replication and mobility of the primosome in a direction opposite chain synthesis. *Proc. Natl Acad. Sci. USA*, **78**, 69-73.
- Asai, T. & Kogoma, T. (1994). D-loops and R-loops: alternate mechanisms for the initiation of chromosome replication in *Escherichia coli*. *J. Bacteriol.* **176**, 1807-1812.
- Asai, T., Bates, D. & Kogoma, T. (1994). DNA replication triggered by double-strand breaks in *E. coli*: dependence on homologous recombination functions. *Cell*, **78**, 1051-1061.
- Ausubel, F. M., Brent, R., Kingston, R. E., Moore, D. D., Seidman, J. G., Smith, J. A. & Struhl, K. (1992). *Current Protocols in Molecular Biology*, Jacob Wiley & Sons, New York.
- Baker, T. A., Sekimizu, K., Funnell, B. E. & Kornberg, A. (1986). Extensive unwinding of the plasmid template during staged enzymatic initiation of DNA replication from the origin of the *Escherichia coli* chromosome. *Cell*, **45**, 53-64.
- Bierne, H. & Michel, B. (1994). When replication forks stop. *Mol. Microbiol.* **13**, 17-23.
- Bramhill, D. & Kornberg, A. (1988). Duplex opening by DnaA protein at novel sequences in initiation of replication at the origin of the *E. coli* chromosome. *Cell*, **52**, 743-755.
- Bujalowski, W. & Jezewska, M. J. (1995). Interactions of *Escherichia coli* primary replicative helicase DnaB protein with single-stranded DNA. The nucleic acid does not wrap around the protein hexamer. *Biochemistry*, **34**, 8513-8519.
- Courcelle, J., Carswell-Crumpton, C. & Hanawalt, P. C. (1997). *recF* and *recR* are required for the resumption of replication at DNA replication forks in *Escherichia coli*. *Proc. Natl Acad. Sci. USA*, **94**, 3714-3719.
- Craigie, R. & Mizuuchi, K. (1985). Mechanism of transposition of bacteriophage Mu: structure of a transposition intermediate. *Cell*, **41**, 867-876.
- Craigie, R. & Mizuuchi, K. (1987). Transposition of Mu DNA: joining of Mu to target DNA can be uncoupled from cleavage at the ends of Mu. *Cell*, **51**, 493-501.
- Craigie, R., Mizuuchi, M. & Mizuuchi, K. (1984). Site-specific recognition of the bacteriophage Mu ends by the Mu A protein. *Cell*, **39**, 387-394.
- Craigie, R., Arndt-Jovin, D. J. & Mizuuchi, K. (1985). A defined system for the DNA strand-transfer reaction at the initiation of bacteriophage Mu transposition: protein and DNA substrate requirements. *Proc. Natl Acad. Sci. USA*, **82**, 7570-7574.
- Funnell, B. E., Baker, T. A. & Kornberg, A. (1987). *In vitro* assembly of a prepriming complex at the origin of the *Escherichia coli* chromosome. *J. Biol. Chem.* **262**, 10327-10334.
- Jones, J. M. & Nakai, H. (1997). The ϕ X174-type primosome promotes replisome assembly at the site of recombination in bacteriophage Mu transposition. *EMBO J.* **16**, 6886-6895.
- Kogoma, T. (1996). Recombination by replication. *Cell*, **85**, 625-627.
- Kogoma, T. (1997). Stable DNA replication: interplay between DNA replication, homologous recombination, and transcription. *Microbiol. Mol. Biol. Rev.* **61**, 212-238.
- Kogoma, T., Cadwell, G. W., Barnard, K. G. & Asai, T. (1996). The DNA replication priming protein, PriA, is required for homologous recombination and double-strand break repair. *J. Bacteriol.* **178**, 1258-1264.
- Krukltis, R. & Nakai, H. (1994). Participation of bacteriophage Mu A protein and host factors in initiation of Mu DNA synthesis *in vitro*. *J. Biol. Chem.* **269**, 16469-16477.
- Krukltis, R., Welty, D. J. & Nakai, H. (1996). ClpX protein of *Escherichia coli* activates bacteriophage Mu transposase in the strand transfer complex for initiation of Mu DNA synthesis. *EMBO J.* **15**, 935-944.
- Kuo, C.-F., Zou, A., Jayaram, M., Getzoff, E. & Harshey, R. (1991). DNA-protein complexes during attachment-site synapsis in Mu DNA transposition. *EMBO J.* **10**, 1585-1591.
- Kuzminov, A. (1995). Collapse and repair of replication forks in *Escherichia coli*. *Mol. Microbiol.* **16**, 373-384.
- Lasken, R. S. & Kornberg, A. (1988). The primosomal protein n' of *Escherichia coli* is a DNA helicase. *J. Biol. Chem.* **263**, 5512-5518.
- Lavoie, B. D. & Chaconas, G. (1990). Immunoelectron microscopic analysis of the A, B, and HU protein content of bacteriophage Mu transpososomes. *J. Biol. Chem.* **265**, 1623-1627.
- Lavoie, B. D. & Chaconas, G. (1993). Site-specific HU binding in the Mu transpososome: conversion of a sequence-independent DNA-binding protein into a chemical nuclease. *Genes Dev.* **7**, 2510-2519.
- Lavoie, B. D. & Chaconas, G. (1994). A second high affinity HU binding site in the phage Mu transpososome. *J. Biol. Chem.* **269**, 15571-15576.
- Lavoie, B. D., Chan, B. S., Allison, R. G. & Chaconas, G. (1991). Structural aspects of a higher order nucleoprotein complex: induction of an altered DNA structure at the Mu-host junction of the Mu type 1 transpososome. *EMBO J.* **10**, 3051-3059.
- Learn, B. A., Um, S. J., Huang, L. & McMacken, R. (1997). Cryptic single-stranded-DNA binding activities of the phage lambda P and *Escherichia coli* DnaC replication initiation proteins facilitate the transfer of *E. coli* DnaB helicase onto DNA. *Proc. Natl Acad. Sci. USA*, **94**, 1154-1159.
- LeBowitz, J. H. & McMacken, R. (1986). The *Escherichia coli* DnaB replication protein is a DNA helicase. *J. Biol. Chem.* **261**, 4738-4748.
- Lee, E. H. & Kornberg, A. (1991). Replication deficiencies in *priA* mutants of *Escherichia coli* lacking the primosomal replication n' protein. *Proc. Natl Acad. Sci. USA*, **88**, 3029-3032.
- Lee, E. H., Masai, H., Allen, G. C. & Kornberg, A. (1990). The *priA* gene encoding the primosomal replicative n' protein of *Escherichia coli*. *Proc. Natl Acad. Sci. USA*, **87**, 4620-4624.
- Lee, M. S. & Marians, K. J. (1987). *Escherichia coli* replication factor Y, a component of the primosome, can

- act as a DNA helicase. *Proc. Natl Acad. Sci. USA*, **84**, 8345-8349.
- Lee, M. S. & Marians, K. J. (1989). The *Escherichia coli* primosome can translocate actively in either direction along the DNA strand. *J. Biol. Chem.* **264**, 14531-14542.
- Levchenko, I., Luo, L. & Baker, T. A. (1995). Disassembly of the Mu transposase tetramer by the ClpX chaperone. *Genes Dev.* **9**, 2399-2408.
- Liu, J., Nurse, P. & Marians, K. J. (1996). The ordered assembly of the ϕ X174-type primosome: PriB facilitates complex formation between PriA and DnaT. *J. Biol. Chem.* **271**, 15656-15661.
- Marians, K. J. (1995). ϕ X174-type primosomal proteins: purification and assay. *Methods Enzymol.* **262**, 507-521.
- Masai, H., Asai, T., Kubota, Y., Arai, K. & Kogoma, T. (1994). *Escherichia coli* PriA protein is essential for inducible and constitutive stable DNA replication. *EMBO J.* **13**, 5338-5345.
- McGlynn, P., Al-Deib, A. A., Liu, J., Marians, K. J. & Lloyd, R. G. (1997). The DNA replication protein PriA and the recombination protein RecG bind D-loops. *J. Mol. Biol.* **270**, 212-221.
- Minden, J. S. & Marians, K. J. (1985). Replication of pBR322 DNA *in vitro* with purified proteins. *J. Biol. Chem.* **260**, 9316-9325.
- Mizuuchi, M., Baker, T. A. & Mizuuchi, K. (1992). Assembly of the active form of the transposase-Mu DNA complex: a critical control point in Mu transposition. *Cell*, **70**, 303-311.
- Nakai, H. & Krukltis, R. (1995). Disassembly of the bacteriophage Mu transposase for the initiation of Mu DNA replication. *J. Biol. Chem.* **270**, 19591-19598.
- Ng, J. Y. & Marians, K. J. (1996a). The ordered assembly of the ϕ X174-type primosome: isolation and identification of intermediate protein-DNA complexes. *J. Biol. Chem.* **271**, 15642-15648.
- Ng, J. Y. & Marians, K. J. (1996b). The ordered assembly of the ϕ X174-type primosome: preservation of primosome composition from assembly through replication. *J. Biol. Chem.* **271**, 15649-15655.
- Nurse, P., Zavitz, K. H. & Marians, K. J. (1991). Inactivation of the *Escherichia coli* PriA DNA replication protein induces the SOS response. *J. Bacteriol.* **173**, 6686-6693.
- Pace, C. N., Vajdos, F., Fee, L., Grimsley, G. & Gray, T. (1995). How to measure and predict the molar absorption coefficient of a protein. *Protein Sci.* **4**, 2411-2423.
- Rupp, W. D. & Howard-Flanders, P. (1968). Discontinuities in the DNA synthesized in an excision-defective strain of *Escherichia coli* following ultraviolet irradiation. *J. Mol. Biol.* **31**, 291-304.
- Sambrook, J., Fritsch, E. F. & Maniatis, T. (1989). *Molecular Cloning, A Laboratory Manual*, 2nd edit., Cold Spring Harbor Laboratory Press, Cold Spring Harbor, NY.
- Sandler, S. J., Samra, H. S. & Clark, A. J. (1996). Differential suppression of *priA2::kan* phenotypes in *Escherichia coli* K-12 by mutations in *priA*, *lexA*, and *dnaC*. *Genetics*, **143**, 5-13.
- Sassanfar, M. & Roberts, J. W. (1990). Nature of the SOS-inducing signal in *Escherichia coli*: the involvement of DNA replication. *J. Mol. Biol.* **212**, 79-96.
- Shlomai, J. & Kornberg, A. (1980a). An *Escherichia coli* replication protein that recognizes a unique sequence hairpin within a region of ϕ X174 DNA. *Proc. Natl Acad. Sci. USA*, **77**, 799-803.
- Shlomai, J. & Kornberg, A. (1980b). A prepriming DNA replication enzyme of *Escherichia coli*. I. Purification of protein ν' : a sequence-specific, DNA-dependent ATPase. *J. Biol. Chem.* **255**, 6789-6783.
- Surette, M. G., Buch, S. J. & Chaconas, G. (1987). Transpososomes: stable protein-DNA complexes involved in the *in vitro* transposition of bacteriophage Mu DNA. *Cell*, **49**, 253-262.
- Svoboda, D. L. & Vos, J. H. (1995). Differential replication of a single, UV-induced lesion in the leading or lagging strand by a human cell extract: fork uncoupling or gap formation. *Proc. Natl Acad. Sci. USA*, **92**, 11975-11979.
- Tougo, K., Peng, H. & Marians, K. J. (1994). Identification of a domain of *Escherichia coli* primase required for functional interaction with the DnaB helicase at the replication fork. *J. Biol. Chem.* **269**, 4675-4682.
- Wahle, E., Lasken, R. S. & Kornberg, A. (1989a). The DnaB-DnaC replication protein complex of *Escherichia coli*. II. Role of the complex in mobilizing *dnaB* functions. *J. Biol. Chem.* **264**, 2469-2475.
- Wahle, E., Lasken, R. S. & Kornberg, A. (1989b). The DnaB-DnaC replication protein complex of *Escherichia coli*. I. Formation and properties. *J. Biol. Chem.* **264**, 2463-2468.
- Wickner, S. & Hurwitz, J. (1974). Conversion of ϕ X174 viral DNA to double-stranded form by purified *Escherichia coli* proteins. *Proc. Natl Acad. Sci. USA*, **71**, 4120-4124.
- Yuzhakov, A., Turner, J. & O'Donnell, M. (1996). Replisome assembly reveals the basis for asymmetric function in leading and lagging strand replication. *Cell*, **86**, 877-886.
- Zavitz, K. H. & Marians, K. J. (1992). ATPase-deficient mutants of the *Escherichia coli* DNA replication protein PriA are capable of catalyzing the assembly of active primosomes. *J. Biol. Chem.* **267**, 6933-6940.
- Zipursky, S. L. & Marians, K. J. (1980). Identification of two *Escherichia coli* factor Y effector sites near the origins of replication of plasmids ColE1 and pBR322. *Proc. Natl Acad. Sci. USA*, **77**, 6521-6525.
- Zipursky, S. L. & Marians, K. J. (1981). *Escherichia coli* factor Y sites of plasmid pBR322 can function as origins of DNA replication. *Proc. Natl Acad. Sci. USA*, **78**, 6111-6115.

Edited by M. Gottesman

(Received 11 January 1999; received in revised form 1 April 1999; accepted 5 April 1999)