



NAVAL FACILITIES ENGINEERING SERVICE CENTER
Port Hueneme, California 93043-4370

Contract Report CR 00-003-AMP

UPDATED CALCULATIONS FOR THE ROLL STABILITY OF THE AUTONOMOUS MARINE BOOSTER PUMP

An Investigation Conducted by:

Howland Associates
Danville, New Hampshire

August 2000

Approved for public release; distribution is unlimited.

DISCONTINUED

 Printed on recycled paper

20001003 081

REPORT DOCUMENTATION PAGE			Form Approved OMB No. 0704-018	
Public reporting burden for this collection of information is estimated to average 1 hour per response, including the time for reviewing instructions, searching existing data sources, gathering and maintaining the data needed, and completing and reviewing the collection of information. Send comments regarding this burden estimate or any other aspect of this collection information, including suggestions for reducing this burden, to Washington Headquarters Services, Directorate for Information and Reports, 1215 Jefferson Davis Highway, Suite 1204, Arlington, VA 22202-4302, and to the Office of Management and Budget, Paperwork Reduction Project (0704-0188), Washington, DC 20503.				
1. AGENCY USE ONLY (Leave blank)	2. REPORT DATE August 2000		3. REPORT TYPE AND DATES COVERED Not Final; April 1999 - July 1999	
4. TITLE AND SUBTITLE UPDATED CALCULATIONS FOR THE ROLL STABILITY OF THE AUTONOMOUS MARINE BOOSTER PUMP			5. FUNDING NUMBERS Contract No.: N47408-96-C-7220	
6. AUTHOR(S) John S. Howland and Martin Fickel (NFESC)				
7. PERFORMING ORGANIZATION NAME(S) AND ADDRESS(S) Howland Associates 207 Main Street P. O. Box 999 Danville, New Hampshire 03819-0999			8. PERFORMING ORGANIZATION REPORT NUMBER CR 00-003-AMP	
9. SPONSORING/MONITORING AGENCY NAME(S) AND ADDRESSES Office of Naval Research Naval Facilities Engineering Service Center Alexandria, VA 22217-5000 1100 23rd Avenue Port Hueneme, California 93043			10. SPONSORING/MONITORING AGENCY REPORT NUMBER	
11. SUPPLEMENTARY NOTES				
12a. DISTRIBUTION/AVAILABILITY STATEMENT Approved for public release; distribution is unlimited.			12b. DISTRIBUTION CODE	
13. ABSTRACT (Maximum 200 words) During an amphibious assault, the forces ashore are supplied with fuel that is transferred through a buoyant hose line from Navy ships. Over standoff distances of 10,000 feet or more, it is necessary to boost the line pressure at intermediate points along the hose line to maintain the flow rate. The autonomous marine booster pump (AMBP) program was started by the Naval Facilities Engineering Service Center (NFESC) to develop a floating booster pump system that could be remotely controlled, self-powered, and cooled by the product in the hose line. Howland Associates was contracted by NFESC to design and fabricate a prototype of the AMBP. Before fabrication, roll stability calculations for the AMBP were made based on design drawings. After the equipment pallet (i.e., the AMBP without the hull) was built, its weight and balance data were experimentally determined and combined with design estimates for the hull, which was not fabricated. This report documents the changes in the AMBP's estimated weight, center of gravity, freeboard, and righting moments corresponding to roll angles 0 and 15 degrees.				
14. SUBJECT TERMS Autonomous marine booster pump (AMBP), fuel transfer, amphibious fuel supply, self-powered fuel pump, buoyant hose line, floating booster pump			15. NUMBER OF PAGES 24	
			16. PRICE CODE	
17. SECURITY CLASSIFICATION OF REPORT Unclassified	18. SECURITY CLASSIFICATION OF THIS PAGE Unclassified	19. SECURITY CLASSIFICATION OF ABSTRACT Unclassified	20. LIMITATION OF ABSTRACT UL	

1. INTRODUCTION

Earlier in Phase II of this program, the roll stability of the Autonomous Marine Booster Pump (AMBP) was estimated, assuming the weights and center of mass locations estimated from the CAD design drawings. (1)*

This phase of the program included a specific task to measure the actual weight and the location of the center of mass for the equipment pallet including the diesel engine, the pump, the piping and all of the controls. By substituting this experimentally determined data for the estimates used in the preceding phase of the program, an improved estimate of the roll stability should be attainable.

The calculation in this report is still, of course, a preliminary analysis since it includes actual weight and balance data for only the internal equipment pallet. The weight and balance for the hull is still only that originally estimated from the CAD design data. However, the use of experimental weight and balance data for a major portion of the system should improve the estimate.

2. BACKGROUND

The calculated roll stability from the previous phase is summarized in Table 2.1 which gives values for hull roll displacements from one to 15 degrees. A 200 lb. man standing at the very edge of the deck on the AMBP would create a capsizing moment of about 750 ft.-lbs. Thus, the hull would reach an equilibrium angle of about 3.33 degrees in this case. Another way of expressing the stability is that it would take more than four 200 lb. men standing on the same side to roll the hull 15 degrees.

TABLE 2.1
RIGHTING MOMENTS CORRESPONDING
TO VARIOUS ROLL ANGLES FROM THE EARLIER ANALYSIS

θ , degrees	θ , radians	M, ft.-lbs.
1	0.01745	224.64
5	0.08725	1123.2
10	0.1745	2246.4
15	0.26175	3369.6

*Numbers in parentheses refer to references listed at the end of this report.

3. SUMMARY

After assembling the AMBP equipment pallet, Howland Associates' subcontractor, Engineered Air Systems, Inc. experimentally determined its weight and the location of its center of mass. The experimental procedure used and the data is summarized in their report which is included as Appendix A of this report.

The experimental tests showed that the pallet, when the pipes and pump are filled with water, weighs 5525 lbs. and its c.g. is located about 22.31 inches above the bottom of the skid.

When the estimated values for the equipment pallet are replaced with the experimental values in the overall estimate for the weight and c.g. of the complete AMBP, the overall weight increases to 13,325 lbs. and the c.g. is located about 28.41 inches above the keel or bottom of the hull.

These values were then substituted in the roll stability analysis described in Ref. (1). The results showed that the roll stability is essentially unaffected by the changed values.

However, the increased weight causes the AMBP to sit about 4.3 inches lower in the water, lowering the freeboard. It is unlikely that this will have any deleterious effect on the operation of the system.

Since the estimated weight of the pallet was somewhat low, it would be prudent, during the next phase of the program to closely monitor the weight of the hull as fabrication progresses. If it appears that the original estimated weight was substantially low, some modifications in terms of material or material thickness changes or, perhaps, lightening holes could be made to reduce the weight.

In any case, it is recommended that the weight and c.g. for the hull be measured before flotation testing with the payload and that the entire system be reanalyzed for stability with the actual weight and c.g. numbers.

4. EXPERIMENTAL MEASUREMENT OF WEIGHT AND CENTER OF MASS

Following assembly, the fabrication subcontractor for this phase of the program, Engineered Air Systems, Inc. of St. Louis measured the weight and center of mass location for the AMBP equipment pallet dry, with engine oil and coolant, and with the pump and pipes filled with water.

The test report from Engineered Air Systems, Inc. is attached to this report as Appendix A. However, the data for the system with all fluids is the important case to consider. The relevant data is summarized below in Table 4.1

**TABLE 4.1
WEIGHT AND CENTER OF MASS LOCATION
FOR THE AMBP EQUIPMENT PALLET**

TOTAL WEIGHT	5525 LBS.
LONGITUDINAL C.G. (distance from leveling screws on control panel end)	41.00 INCHES
LATERAL C.G. (distance from leveling screws on the actuator side.)	20.21 INCHES
VERTICAL C.G. (distance above the bottom of the pallet or skid)	22.31 INCHES

5. RECALCULATION OF THE ORIGINAL C. G. LOCATION

The original weight of the entire AMBP was estimated to be 11,390 lbs. and the vertical location of the center of mass was estimated to be 27.8 inches above the bottom of the hull. This location was estimated by combining estimates automatically provided by the CAD design for the original designs embodied in the CAD drawings and the specifications provided by the major component manufacturers and the locations of their components.

In order to correct this estimate using the data provided by Engineered Systems (EASI), it is first necessary to separate out the weight and c.g. data for the equipment pallet in the original estimate. Table 5.1 gives the original weights and moments (weight times the moment arm of the c.g. above the bottom of the hull) for each of the major components of the pallet system used in the original stability analysis.

**TABLE 5.1
ORIGINAL ESTIMATES OF EQUIPMENT PALLET WEIGHTS
AND C. G. MOMENTS**

Component	Weight, lbs.	Moment Arm, inches	Moment, in.-lbs.
Pallet or skid	1103	14.82	16,347
Engine	1250	34.92	43,650
Pump	296	28.33	8,386
Batteries	520	11.84	6,157
Ball Valve and Act.	261	55.26	14,423
Butterfly Valves	160	47.90	7,664
Totals	3590		96,627

The resultant estimated height of the c.g. for the pallet assembly listed in Table 5.1 can simply be found by dividing the moment by the weight. The result was 26.91 inches above the bottom of the hull. Thus, the c.g. of the pallet assembly was estimated to be about an inch below that of the entire AMBP assembly.

The measured weight of the pallet assembly including all fluids is 5525 lbs. or 1935 lbs heavier than the earlier estimate. Thus, for all further calculations, an estimated total weight for the AMBP system of 13,325 lbs. should be used.

Subtracting the depth of the hull floor beams and wall thickness of 6.375 inches from the above earlier estimate of the c.g. height gives a height above the bottom of the skid of 20.54 inches. This is about two inches below the actual measured height of 22.31 inches from Table 4.1.

To recalculate the estimated c.g. height for the whole system, it is convenient to use the moments above the bottom of the hull. The original moment for the entire AMBP was $(11,390)(27.8)$ or

316,642 in.-lbs. Subtracting out the original estimated moment for the equipment pallet of 96,627 in.-lbs. gives a total estimated moment for the rest of the system of 220,015 in.-lbs.

The height of the measured c.g. for the pallet system above the bottom of the hull can be found by adding the measurement of 22.31 inches to the depth of the hull floor beams and skin thickness of 6.375 inches. The result is 28.69 inches

The actual experimentally determined moment for the pallet system can be found by multiplying the weight of 5525 lbs. by the height of 28.69 to give 158,512 in.-lbs.

Adding this moment to that of the hull above gives a total for the system of 378,527 in.-lbs. Dividing this by the total weight of 13,325 lbs. gives a revised estimate of c.g. height of 28.41 inches . These are the new numbers that should be used in the roll stability analysis.

6. REVISED STABILITY ANALYSIS

The calculation of roll stability follows the method of Section 6. of Reference (1). with the substitution of the new weight and c.g. height values from Section 5. of this report.

The design of the hull has not changed since the previous calculation and is shown in Figure 6.1.

It is first necessary to determine the location of the waterline on the hull. The displacements of the various parts of the hull are the same as they were for the previous calculation. Thus, the total displacement of the hull is still 16,507 lbs.

The current estimated total weight of the hull and its contents, W , was determined in Section 5. to be 13,325 lbs. Thus, the reserve buoyancy of the AMBP is the difference between these weights or

$$B = 3182 \text{ lbs.} \quad (6.1)$$

The freeboard of the hull (distance from the deck to the waterline) can be found from

$$f = \frac{B}{64 \times A_D} = 0.594 \text{ ft.} = 7.12 \text{ inches} \quad (6.2)$$

where the deck area is given by

$$\begin{aligned} A_D &= [90 \times 24] + [90 \times 110] = 12,060 \text{ in}^2 \\ &= 83.75 \text{ ft.}^2 \end{aligned} \quad (6.3)$$

Thus, the waterline is predicted to be 7.12 inches from the deck or 32.88 inches from the "keel".

The location of the center of buoyancy from the keel can be determined from the relationship

$$b = \frac{W_L b_1 + W'_U b_2}{W} = 17.2 \text{ inches} \quad (6.4)$$

where b_1 is the distance from the keel to the c.b. of the lower hull which is approximately 9 inches, b_2 is the distance from the keel to the c.b. of the portion of the upper hull below the waterline which is found from

$$b_2 = 18 + (22 - 7.12)/2 = 25.44 \text{ inches} \quad (6.5)$$

W_L was found in the previous report to be 6680 lbs., and W'_U is simply the displacement of that portion of the upper hull below the waterline, 6645 lbs, which can be found by subtracting W_L from the total weight, W .

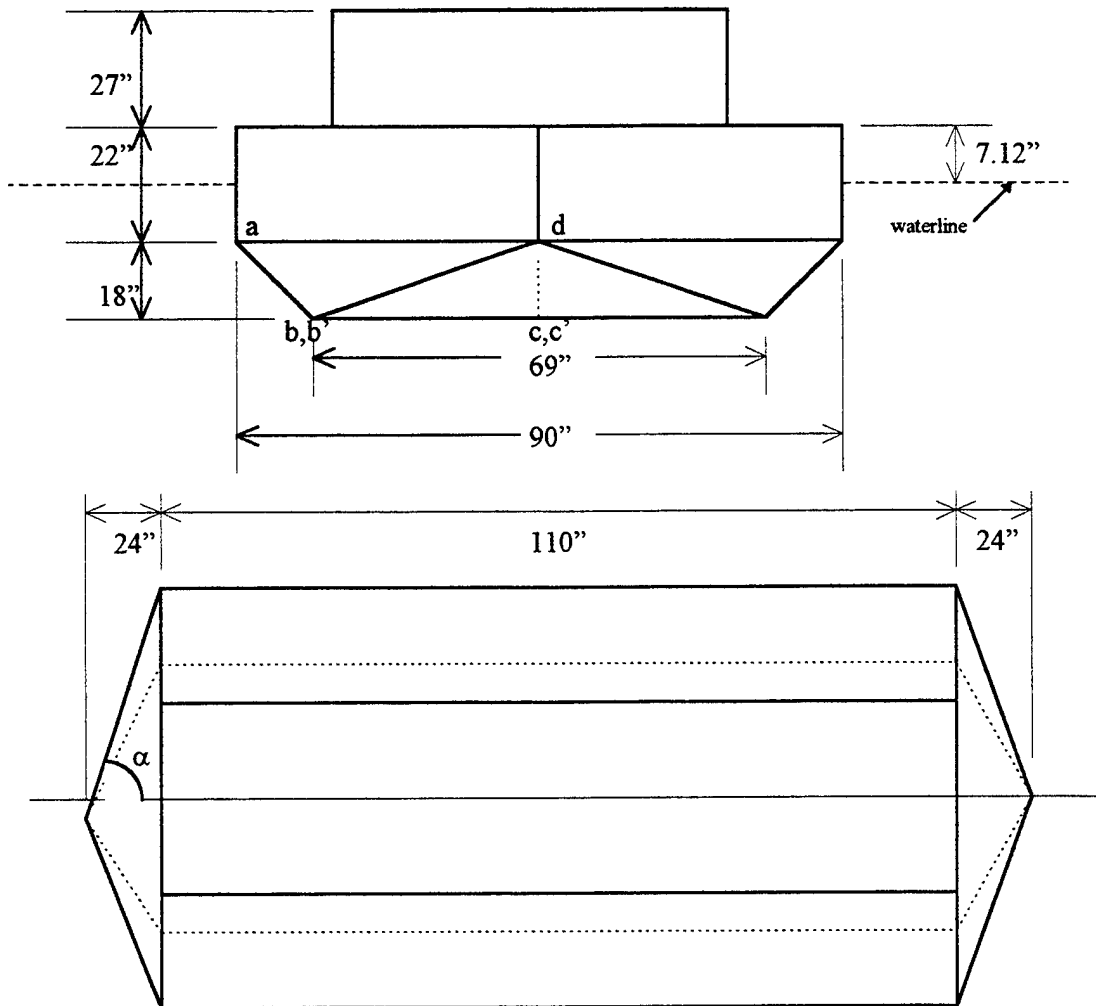

Schematic Diagram of the Hull
 Showing Dimensions and Notation
 Figure 6.1

The metacenter which is the apparent center of rotation for the hull in roll can be located by its distance above the center of buoyancy, b_m , given by the relationship (2)

$$b_m = \frac{I}{V} \quad (6.6)$$

where the moment of inertia of the hull, I , is given by

$$I = 1/12 A_D w^2 = 392.6 \text{ ft}^4, \quad (6.7)$$

A_D is still 83.75 ft^2 and the width of the hull, w , is 7.5 ft .

The volume of the water displaced, V , is the weight of the water, $13,325 \text{ lbs}$. divided by 64 or 208.2 ft^3 . Substituting these values into Eq.(6.6) gives

$$b_m = 392.6/208.2 = 1.886 \text{ ft.} = 22.63 \text{ inches} \quad (6.8)$$

Thus, the metacenter is located at $17.2 + 22.63 = 39.83$ inches from the keel.

The c.g. of the AMBP was estimated in Section 5. as lying at 28.41 inches from the keel and approximately along the centerline. The distance of the metacenter above the c.g., d_{gm} , is, thus, 11.42 inches or 0.95 ft . It is necessary, of course, that the metacenter be located above the c.g. if the system is to be stable in roll.

The degree of stability can be estimated by realizing that the righting moment, M , for small angles of roll, θ , measured in radians can be found from

$$M = W d_{gm} \theta = 12,658 \theta \text{ ft.-lbs.} \quad (6.9)$$

which, it can be seen is almost exactly the same stability as that estimated in Ref. (1) Table 6.1 gives values for the righting moment for roll displacements from one to 15 degrees. A 200 lb. man standing at the very edge of the deck would create a capsizing moment of about 750 ft.-lbs. Thus, the hull would reach an equilibrium angle of about 3.4 degrees in this case. Another way of expressing the stability is that it would take more than four 200 lb. men standing on the same side to roll the hull 15 degrees.

TABLE 6.1
RIGHTING MOMENTS CORRESPONDING
TO VARIOUS ROLL ANGLES

θ , degrees	θ , radians	M , ft.-lbs.
1	0.01745	220.9
5	0.08725	1104.4
10	0.1745	2208.8
15	0.26175	3313.2

This analysis shows that the increased weight and change in the height of the c.g. for the equipment pallet does not alter the roll stability significantly from that calculated using the earlier estimates of weight and c.g. location. However, the increased actual weight will make the whole AMBP sit a little lower in the water. That is, the freeboard below the deck has decreased from 11.46 inches to 7.12 inches or about 4.3 inches.

This probably does not produce any major practical problems. It will be remembered that we selected a point of attachment for the mooring lines which is estimated to produce a very small pitch angle due to mooring forces in a current. Thus, it can be expected that, even with a reduced freeboard, that the deck will not be submerged under normal current conditions. There is, of course a coaming around the hatch which raises it 27 inches above the deck. Thus, even if the deck becomes awash at times, it will not affect the interior compartment.

7. CONCLUSIONS AND RECOMMENDATIONS

On the basis of the experimental measurement of the weight and c.g. location for the AMBP equipment pallet, it can be concluded that the pallet weighs 5525 lbs. and its c.g. is located about 22.31 inches above the bottom of the pallet or skid.

This results in a revised overall weight for the AMBP of 13,325 lbs. and a vertical location of the c.g. of 28.41 inches above the bottom of the hull or the "keel".

Recalculating the roll stability using these revised numbers indicates that the stability is unchanged from the earlier calculations. However, the increased weight will cause the AMBP to sit about 4.3 inches lower in the water.

During the course of the fabrication of the hull, it would probably be prudent to periodically check the weight of the assembly to determine whether the earlier estimates are approximately correct. We would expect that the preliminary estimates of the hull structure would be more accurate than those of the equipment pallet. However, if the original estimates are inaccurate and indicate that roll stability would be a problem, it would likely be easier to correct the problem early in the fabrication process rather than at the end.

In any case, it is recommended that the weight and c.g. for the hull be measured before flotation testing with the payload and the entire system reanalyzed for stability with the experimental numbers.

LIST OF REFERENCES

1. Howland, J.S., Erickson, A.J., Gordon, J. and Berteaux, H.O.; *Conceptual Design of an Autonomous Marine Booster Pump*; Phase II Final Report to the Naval Facilities Engineering Command, Contract N47408-96-C-7220, October, 1997
2. Berteaux, H.O., *Coastal and Ocean Buoy Engineering*, published by Cable Dynamics and Mooring Systems, Inc., Woods Hole, MA, 1991

APPENDIX A
WEIGHT AND C.G. MEASUREMENTS
for the
AUTONOMOUS MARINE BOOSTER PUMP
EQUIPMENT PALLET

WEIGHT AND C.G. TEST REPORT
AUTONOMOUS MARINE BOOSTER PUMP

Contract 98015R1

16 October 1998

submitted by:

Engineered Air Systems, Inc. / 90598

1270 North Price Road • St. Louis, Missouri 63132

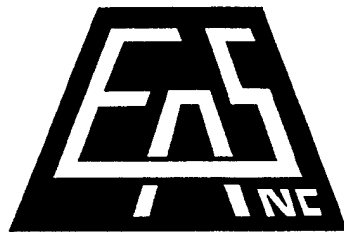

Center of Gravity Evaluation of Autonomous Marine Booster Pump

Purpose: Paragraph 1.2 of the contract requires that the center of gravity of the Engine/Pump /pallet system be determined. The information derived from this test is to be used to provide the required data for later stability tests of the hull subsystem with a dummy load installed.

Test Setup: The pump assembly was placed on four scales so that each of the leveling screws was on an individual scale.

Test Conditions: This test was conducted at laboratory ambient conditions.

Instrumentation and Support Equipment: The following instrumentation was used to record data.

- Scales, Pennsylvania model S400 – 4 required
- Bases, Pennsylvania 600-48x48, 5000lb capacity – 4 required

Procedure: The test was conducted using the Weight Method described in Aberdeen Test Center's TOP 2-2-800 (attached).

Success Criteria: This data is for information only, no specific criteria are applicable.

Results: The unit was initially weighed with no fluids. Then the system was weighed again after 15 qts. of oil and 7 gallons of 50/50 antifreeze mix were installed. The pipes were then filled with water with the exception of the hoses to the heat exchanger and the heat exchanger. The results are shown below. Data sheets are attached.

Table 1, Weight test results			
Item	Dry	W/ antifreeze & oil	With water
Weight on corner #1	1476	1539	1618
Weight on corner #2	1304	1293	1362
Weight on corner #2	1182	1192	1282
Weight on corner #4	1114	1149	1263
Total weight	5076	5173	5525
Longitudinal C.G. Distance from leveling screws on control panel end	40.26	40.27	41.00
Lateral C.G. Distance from leveling screws on actuator side	20.16	20.32	20.21
% off center longitudinally	4.76	4.75	3.93
% off center laterally	2.36	2.78	2.49

The vertical C.G. was then measured. Results are shown in Table 2 below:

Table 2 – Vertical C.G. results	
Condition	Height from bottom of skid
W/ antifreeze & oil	20.21
With water	22.31

TOP 2-2-800

31 December 1993

4.4 Weight Method (used for CG along all three axes).

a. Measure weight reactions P_1 and P_2 at each vehicle axle by means of platform scales (see fig. 3). Also measure distance e between axles, i.e., wheelbase. Calculate a and/or b using formula in upper portion of Figure 3.

b. Place the front (or rear) wheels of the vehicle on a raised platform (step) and the rear (or front) wheels on a platform scale. Knowing this weight reaction and the total vehicle weight, calculate the weight reaction at the opposite set of wheels. The ratio between the step height and the vehicle wheelbase should be approximately 0.3.

c. Determine the vertical CG location by the equation shown in lower portion of Figure 3. Values for r , W , Y_2 , and m are obtained by measurement; values for Y_1 and H are obtained by calculation.

d. Calculate the lateral location of the CG using the method presented in Figure 4. Locate the CG relative to the vehicle longitudinal centerline.

$$b = \frac{P_1 e}{W}$$

$$a = \frac{P_2 e}{W}$$

where:

- b - Distance of CG from forward axle.
- a - Distance of CG from rear axle.
- P₁ - Forward axle weight reaction.
- P₂ - Rear axle weight reaction.
- e - Wheelbase.
- W - Total vehicle weight.

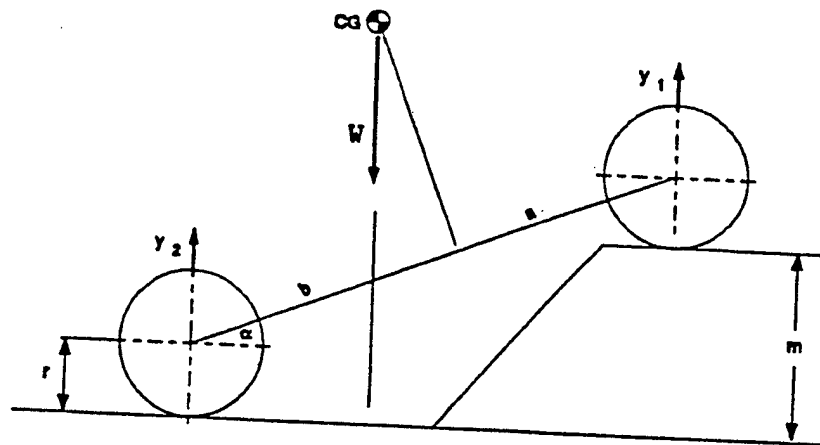
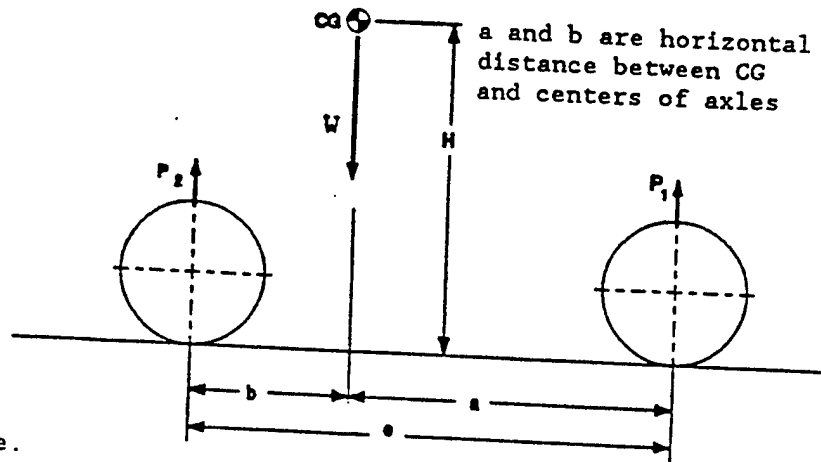

Vehicle with one Axle Raised

$$H = \frac{Y_2 e - W a}{W m} \sqrt{e^2 - m^2 + r}$$

where:

- H - Height of CG above ground level.
- Y₂ - Weight reaction (platform scale reading).
- e - Wheelbase.
- W - Total vehicle weight.
- a - Longitudinal distance between CG and center of raised axle (when level).
- m - Step height.
- r - Radius of wheel and tire combination.

Figure 3. Weight method.



Engineered Air Systems Inc., St. Louis, Missouri

Project: Autonomous Marine Booster Pump (AMBP)

Contract: 98015R1

Test: Weight and Center of Gravity Test Lateral and Longitudinal C.G.

Paragraph: 1.2

dry, no fluids

Date: Oct 12 '98

Tester: [Signature]

Witness: _____

Unit Serial Number: Proto 1

First Article Test

Item	Description	Units	Criteria	Reading
1.	Weight on corner #1 with unit level	Lbs.	N/A	1476
2.	Weight on corner #2 with unit level	Lbs.	N/A	1304
3.	Weight on corner #3 with unit level	Lbs.	N/A	1182
4.	Weight on corner #4 with unit level	Lbs.	N/A	1114
5.	Distance from front to back of block centers	Inches	N/A	89"
6.	Distance from side to side of block centers	Inches	N/A	38.5"
7.	Total weight calculated ($\#1+\#2+\#3+\#4$)	Lbs.	N/A	5076
8.	Longitudinal C.G. distance from control panel end $=((\#3+\#4)*\#5)/\#7$	inches	N/A	40.26
9.	Lateral C.G. distance from actuator side $=((\#1+\#3)*\#6)/\#7$	inches	N/A	20.16

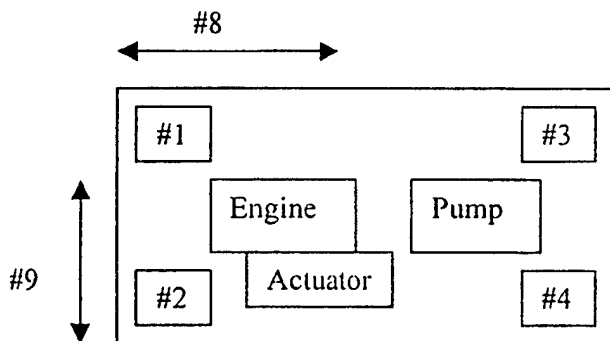



Enginered Air Systems Inc., St. Louis, Missouri

Project: Autonomous Marine Booster Pump (AMBP)

Contract: 98015R1

Test: Weight and Center of Gravity Test Lateral and Longitudinal C.G.

Paragraph: 1.2

Antifreeze oil w/ engine fluids

Date: 10/13/98

Tester: [Signature]

Witness: _____

Unit Serial Number: Proto 1

First Article Test

Item	Description	Units	Criteria	Reading
1.	Weight on corner #1 with unit level	Lbs.	N/A	1539
2.	Weight on corner #2 with unit level	Lbs.	N/A	1293
3.	Weight on corner #3 with unit level	Lbs.	N/A	1192
4.	Weight on corner #4 with unit level	Lbs.	N/A	1149
5.	Distance from front to back of block centers	Inches	N/A	89
6.	Distance from side to side of block centers	Inches	N/A	38.5
7.	Total weight calculated (#1+#2+#3+#4)	Lbs.	N/A	5173
8.	Longitudinal C.G. distance from control panel end = ((#3+#4)*#5)/#7 <i>leveling screws</i>	inches	N/A	40.27
9.	Lateral C.G. distance from actuator side = ((#1+#3)*#6)/#7 <i>leveling screws</i>	inches	N/A	20.325

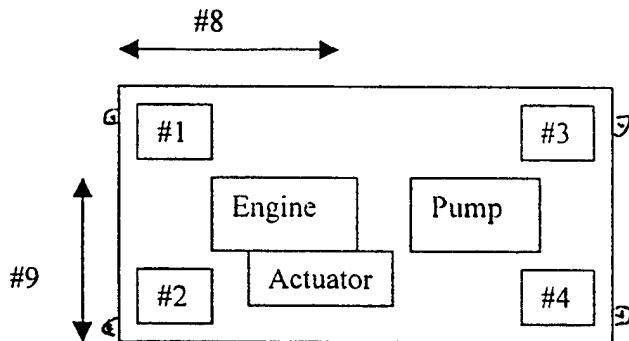

*97 lbs fluid
15 qts oil
7 gallons 50/50 antifreeze mix.*



Engineered Air Systems Inc., St. Louis, Missouri

Project: Autonomous Marine Booster Pump (AMBP)

Contract: 98015R1

Test: Weight and Center of Gravity Test Vertical C.G.

Paragraph: 1.2

W/ engine fluids

Date: 10/13/98

Tester: [Signature]

Witness: _____

Unit Serial Number: Proto 1

First Article Test

Item	Description	Units	Reading
1.	Height of #1 and #2 end	Inches	26.0
2.	Weight on corner #3	Lbs.	1288
3.	Weight on corner #4	Lbs.	1408
4.	Total weight of #3 & #4	Lbs.	2696
5.	Total length of unit	Inches	89
6.	Height of C.G. above ground $= \frac{(\text{Item 4} * \text{Item 5}) - (\text{Weight} * \text{Item \#8 from previous sheet})}{\text{Weight} * \text{Item \#1}}$	Inches	20.015

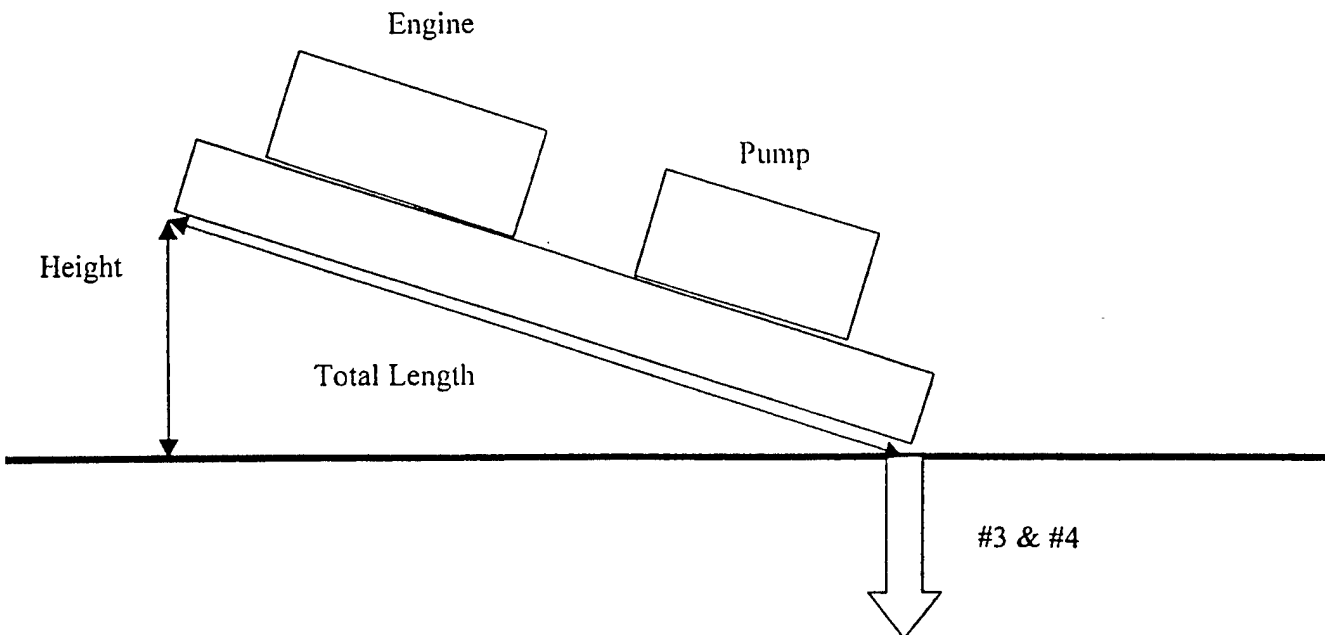



Engineered Air Systems Inc., St. Louis, Missouri

Project: Autonomous Marine Booster Pump (AMBP)

Contract: 98015R1

Test: Weight and Center of Gravity Test Lateral and Longitudinal C.G.

Paragraph: 1.2

Pipes filled w/ water

Date: 10/14/98

Tester: [Signature]

Witness: _____

Unit Serial Number: Proto 1

First Article Test

Item	Description	Units	Criteria	Reading
1.	Weight on corner #1 with unit level	Lbs.	N/A	1618
2.	Weight on corner #2 with unit level	Lbs.	N/A	1362
3.	Weight on corner #3 with unit level	Lbs.	N/A	1282
4.	Weight on corner #4 with unit level	Lbs.	N/A	1263
5.	Distance from front to back of block centers	Inches	N/A	89
6.	Distance from side to side of block centers	Inches	N/A	38.5
7.	Total weight calculated (#1+#2+#3+#4)	Lbs.	N/A	5525
8.	Longitudinal C.G. distance from control panel end = ((#3+#4)*#5)/#7	inches	N/A	40.996
9.	Lateral C.G. distance from actuator side = ((#1+#3)*#6)/#7	inches	N/A	20.21

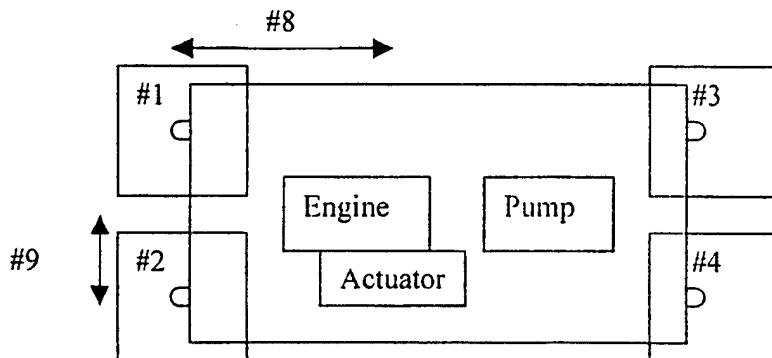



Engineered Air Systems Inc., St. Louis, Missouri

Project: Autonomous Marine Booster Pump (AMBP)

Contract: 98015R1

Test: Weight and Center of Gravity Test Vertical C.G.

Paragraph: 1.2

Date: 10/14/98

Tester: [Signature]

Witness: _____

Unit Serial Number: Proto 1

First Article Test

Item	Description	Units	Reading
1.	Height of #1 and #2 end	Inches	26
2.	Weight on corner #3	Lbs.	1283
3.	Weight on corner #4	Lbs.	1685
4.	Total weight of #3 & #4	Lbs.	2968
5.	Total length of unit	Inches	87
6.	Height of C.G. above ground $= \frac{264152 \cdot 5525 + 226302.9 \cdot 40.716}{143650} \sqrt{85.117^2 - \text{height}^2}$	Inches	22.31

