

F&H Applied Science Associates Inc.
PO Box 853
Moorestown, NJ 08057-0853

N97-028

Item 0003AC Final Technical Report for Option
Period Covering May 5, 1998 to August 5, 1998
Contract #N00421-97-C-1204, contract dollar amount \$29,999
competitively awarded

Sponsor: Mike Contarino Code 4.5.5.6
EO Sensors
Bldg 2185 Suite 1100
NAWCAD
22347 Cedar Point Rd. Unit 6
Patuxent River, MD 29670-1161

Accounting data:

AB: 1781319.46ED 255 AAA32 0 068342 2D 05324Q W18120009990
DIRECT SITE: N0001998RXB713R
490 001 JON: C000012291 ACRN:AB \$29,999

DISTRIBUTION STATEMENT A
Approved for Public Release
Distribution Unlimited

DTIC QUALITY INSPECTED 4

20001012 017

REPORT DOCUMENTATION PAGE			Form Approved OMB No. 0704-0188	
Public reporting burden for this collection of information is estimated to average 1 hour per response, including the time for reviewing instructions, searching existing data sources, gathering and maintaining the data needed, and completing and reviewing the collection of information. Send comments regarding this burden estimate or any other aspect of this collection of information, including suggestions for reducing this burden to Washington Headquarters Services, Directorate for Information Operations and Reports, 1215 Jefferson Davis Highway, Suite 1204, Arlington, VA 22202-4302, and to the Office of Management and Budget, Paperwork Reduction Project (0704-0188), Washington, DC 20503.				
1. AGENCY USE ONLY (Leave blank)	2. REPORT DATE 98AUG14	3. REPORT TYPE AND DATES COVERED Final Report 5MAY98-5AUG98		
4. TITLE AND SUBTITLE Large Area, High Speed Photodiode Using Metal-Semiconductor-Metal (MSM) Device			5. FUNDING NUMBERS C-N00421-97- C-1204	
6. AUTHOR(S) Tamera Yost Robert Fischl Peter Merczfeld				
7. PERFORMING ORGANIZATION NAMES(S) AND ADDRESS(ES) F&H Applied Science Associates, Inc. P. O. Box 853 Moorestown, NJ 08057-0853			8. PERFORMING ORGANIZATION REPORT NUMBER 0003-AC	
9. SPONSORING / MONITORING AGENCY NAMES(S) AND ADDRESS(ES) Vincent M. Contarino Code 4.5.5.6 EO Sensors, Bldg 2185 Suite 1100 NAWCAD 22347 Cedar Point Rd. Unit 6 Patuxent River, MD 29670-1161			10. SPONSORING / MONITORING AGENCY REPORT NUMBER	
11. SUPPLEMENTARY NOTES				
a. DISTRIBUTION / AVAILABILITY STATEMENT A-Public Release; Unlimited Distribution			12. DISTRIBUTION CODE	
13. ABSTRACT (Maximum 200 words) This report summarizes the experimental results of a novel high speed, large area photodetector with gain. The photodetector characteristics include an 8 mm diameter active area, noise figure < 1.5 dB, electron gain of greater than 1000 with a bandwidth of 3-5 GHz. The prototype unit is a vacuum phototube with a metal-semiconductor-metal (MSM) anode. Although the experimental results indicated a fabrication error caused the poor performance, initial results show great promise in achieving the design specifications as stated.				
14. SUBJECT TERMS Large Area Photodetector, Lidar, Metal-Semiconductor-Metal Device			15. NUMBER OF PAGES 15	
			16. PRICE CODE	
17. SECURITY CLASSIFICATION OF REPORT unclassified	18. SECURITY CLASSIFICATION OF THIS PAGE unclassified	19. SECURITY CLASSIFICATION OF ABSTRACT unclassified	20. LIMITATION OF ABSTRACT SAR	

Contract #N00421-97-C-1204

Item 0003AC Final Option Period Report covering May 5, 1998 to August 5, 1998

Project title: Large Area, High Speed Photodiode using Metal-Semiconductor
Metal(MSM) Device

This is the Final Report/Scientific Technical Paper on the project titled "Large Area, High Speed Photodiode using Metal-Semiconductor-Metal (MSM) Device" covering the Option period from May 5 to August 5, 1998. A review of the main scope of the project and a summary of the Phase I work will be presented. The Option work tasks and results will be reproduced. This report concludes with a summary of Option completed work and discusses the plan of Phase II.

Review

This project concerns with the development of a large area, high speed photodetector with gain. It involves the incorporation of a metal-semiconductor-metal (MSM) device as the anode in a large area phototube that currently uses a Schottky diode [1]. This phototube, or intensified photodiode (IPD), is expected to exhibit a gain of greater than 10^3 , noise figure less than 1.5 dB, and a bandwidth greater than 10 GHz, while maintaining an 10 mm or larger active area. The device will be useful in free space communications, such as satellite to satellite links, and in a variety of Light Detection and Ranging (Lidar) applications. Specifically, this device functions in the blue-green region of the spectrum, where Navy aerial Lidar operates.

Most current systems employ silicon PIN diodes, InGaAs Schottky diodes, photomultiplier tubes (PMTs), and silicon avalanche photodiodes (APDs) as photodetectors. Each photodetector has advantages and disadvantages. The discrete device photodetectors such as the PIN and Schottky diodes can provide high bandwidth, but suffer from small active area. For example, a silicon PIN with a 0.4 mm active area has a bandwidth of 1 GHz, responsivity of 0.6 A/W with a noise equivalent power of 71 pW/Hz^{1/2}. An InGaAs Schottky diode with a 25 mm active area has a bandwidth of 6 GHz, but lower responsivity of 0.2 A/W with a noise equivalent power of 60 pW/Hz^{1/2}. On the other hand, a PMT and APD can provide large active area and detection of low

Contract #N00421-97-C-1204

Item 0003AC Final Option Period Report covering May 5, 1998 to August 5, 1998

Project title: Large Area, High Speed Photodiode using Metal-Semiconductor
Metal(MSM) Device

light levels, but suffer from bandwidth limitations. For both these devices the amplification process limits the time response. For a side-on PMT with an active area of 8 mm, the responsivity is greater than 10^5 A/W, the noise equivalent power is 5×10^{-4} pW/Hz^{1/2}, but the bandwidth is less than 100 MHz. A silicon APD with 10 mm active area exhibits a responsivity of 0.35 A/W with a gain of 80, a the noise equivalent power of 4×10^{-4} pW/Hz^{1/2}, but also has a bandwidth less than 100 MHz. The IPD combines the high speed capability of a discrete device as the anode with a fast electron transit time and amplification process. Currently the IPD has a bandwidth of 2-3 GHz, however the incorporation of the MSM as the anode should increase the speed beyond 10 GHz while maintaining the current device size. The proposed device will have large area and high speed beyond what is available today, thus it will be a significant addition to photodetectors used in communications and in Lidar.

The vacuum photodiode or intensified photodiode (IPD) consists of an 8 mm photocathode, an electron focusing and accelerating structure, and a electron bombarded semiconductor device. A block diagram is shown in Figure 1. Incident photons strike the surface of the blue-green sensitive GaAsP photocathode, which creates a beam of photogenerated electrons within the vacuum tube. The beam of electrons is accelerated by a voltage of several kV applied across the vacuum tube and focused by two electrostatic rings. The focused beam of high energy electrons bombards the semiconductor device which generates carriers greater than 1000 times the number of incident electrons via impact ionization of the semiconductor lattice.

Electron bombarded GaAs devices that have been used include a 0.5 mm PIN diode, a 0.5 mm Schottky diode, and a 0.3 mm Schottky diode. The IPD has a large active area with high gain, however the speed of the device is limited by the electron bombarded device. To increase the speed of the IPD, the size of the diode should be decreased, however, the spot size of the electron beam is approximately 200 μ m and limits how small the diode can be to achieve proper focusing. These limitations set the design

Contract #N00421-97-C-1204

Item 0003AC Final Option Period Report covering May 5, 1998 to August 5, 1998

Project title: Large Area, High Speed Photodiode using Metal-Semiconductor Metal(MSM) Device

criteria of the replacement MSM at a minimum active area of $300\ \mu\text{m} \times 300\ \mu\text{m}$ with a bandwidth of at least 10 GHz, while maintaining the electron bombardment gain.

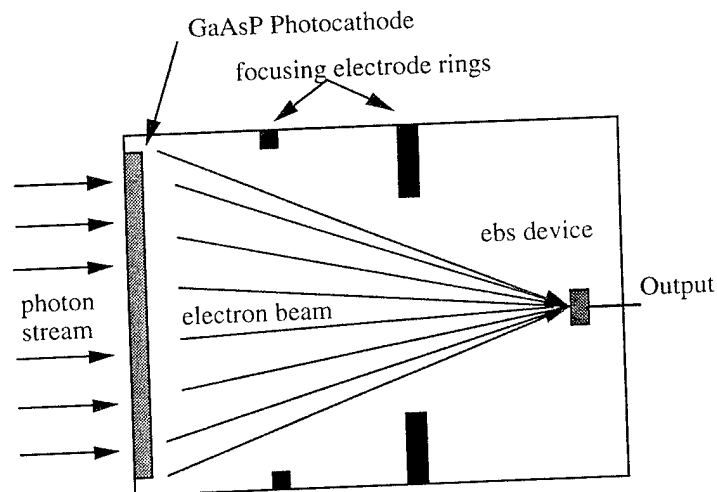

Figure 1. Intensified Photodiode Structure

The MSM device offers many advantages including bandwidths exceeding 100 GHz [2], low capacitance due to the interdigital electrode structure, low dark current, and ease and low cost of fabrication. The geometry of an interdigital MSM is shown in Figure 2 and consists of metal pads and electrodes deposited on bulk GaAs.

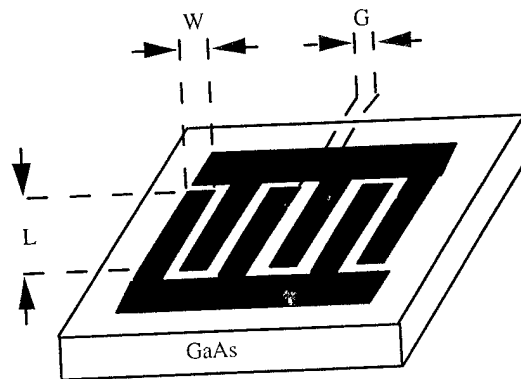

Figure 2. MSM Device

Contract #N00421-97-C-1204

Item 0003AC Final Option Period Report covering May 5, 1998 to August 5, 1998

Project title: Large Area, High Speed Photodiode using Metal-Semiconductor
Metal(MSM) Device

The electrodes have a length L, width W, and gap spacing G. Essentially, the device is two Schottky diodes in a back-to-back arrangement, since one electrode has a positive bias and the other a negative bias.

Phase I Summary

The technical objectives of Phase I were to develop the program specifications, design the large area, high speed photodetector to these specifications, and completely characterize the MSM device optically for use in a prototype unit to be fabricated during the Option.

The program specifications included development of a photodetector with a 10 mm area, gain greater than 10^3 , noise figure less than 1.5 dB, and bandwidth greater than 10 GHz. The plan for the design of the 10 GHz photodetector was developed in a two step process. First a lower bandwidth prototype will be evaluated where the anode replacement of the IPD is the MSM device. The MSM would provide an increased bandwidth of the IPD from 2 GHz to 4 GHz. Design, fabrication, and characterization of the MSM was the main focus of the Phase I work. Information gained from the prototype would be used to fine tune the design for the 10 GHz photodetector.

The initial design of the MSM for operation to 5 GHz was performed using a simple one dimensional photodetector model. An MSM with area $300 \mu\text{m}^2$, electrode width of $8 \mu\text{m}$ and gap of $4 \mu\text{m}$ was determined to be the optimal geometry. The electron bombardment gain of this device was predicted to be 1450. Although, these one

Contract #N00421-97-C-1204

Item 0003AC Final Option Period Report covering May 5, 1998 to August 5, 1998

Project title: Large Area, High Speed Photodiode using Metal-Semiconductor
Metal(MSM) Device

dimensional models are adequate for initial design, a two dimensional model of electron bombardment performance was developed. Using this new model, a bandwidth of 4 GHz and gain of 1055 were predicted for the above MSM under electron bombardment.

Characterization results of the fabricated MSM device show excellent DC characteristics and a measured bandwidth of 4.1 GHz. Therefore, it can be assumed that the models developed can closely predict the MSM performance under electron bombardment.

All of the objectives of Phase I have been met with great success. It has been shown that replacement of the IPD anode with a metal-semiconductor-metal device can increase the overall photodetector speed without compromising the active area, noise, or gain.

Work Plan for the Option

Four specific tasks were outlined for Phase I and include:

Task III. Complete characterization of the 3 GHz MSM device and MSM-IPD detector.

This task involves the complete characterization of the 3GHz MSM and the integrated MSM-IPD detector. There are three subtasks(IIIB-D) defined which involve a proof of concept demonstration of the detector.

III-B. Mounting of the three to five best MSM devices on headers.

III-C. Complete characterization of the mounted MSM devices under electron bombardment. Correlation of the results obtained with electron bombardment and optical characterization.

Contract #N00421-97-C-1204

Item 0003AC Final Option Period Report covering May 5, 1998 to August 5, 1998

Project title: Large Area, High Speed Photodiode using Metal-Semiconductor Metal(MSM) Device

III-D. Incorporation of the best MSM device into the IPD and complete characterization of the novel IPD, including bandwidth, noise, gain, responsivity and dynamic range.

Task IV. Electromagnetic focusing optimization.
Magnetic focusing, to assist the electric focusing of the IPD, will be investigated.

Task IIIB

The MSM devices that were fabricated in the Drexel University cleanroom were unable to be wire bonded due to poor electrode metal adhesion to the GaAs wafer. Therefore, a complete set of MSM devices were fabricated on undoped GaAs at the Intevac facility clean room. Two MSM devices were successfully mounted on IPD tube headers.

Task IIIC

One mounted MSM device showed asymmetric behavior under dark conditions and was determined to be defective. The second device that was mounted was subsequently tested optically. The DC dark and photoresponse data is shown in Figure 3. The device shows excellent symmetry and photoresponse of nearly 0.3 A/W, but has relatively high dark current of nearly 1 μ A at a bias of 15V. Previous devices fabricated on a thin layer of Intermediate Growth Temperature (IGT) GaAs showed dark current levels of less than 10 nA for the same range of DC bias voltages with similar photoresponse results. Comparison of these results proves the benefit gained when using the IGT GaAs over conventional GaAs. Measurement of the optical frequency response showed a bandwidth of 4.2 GHz, clearly indicating that the mounting header does not add any parasitics that limit the response of the MSM to a bandwidth of less than 5 GHz. Further studies will be conducted to determine the limitations at 10 GHz.

Contract #N00421-97-C-1204
 Item 0003AC Final Option Period Report covering May 5, 1998 to August 5, 1998
 Project title: Large Area, High Speed Photodiode using Metal-Semiconductor
 Metal(MSM) Device

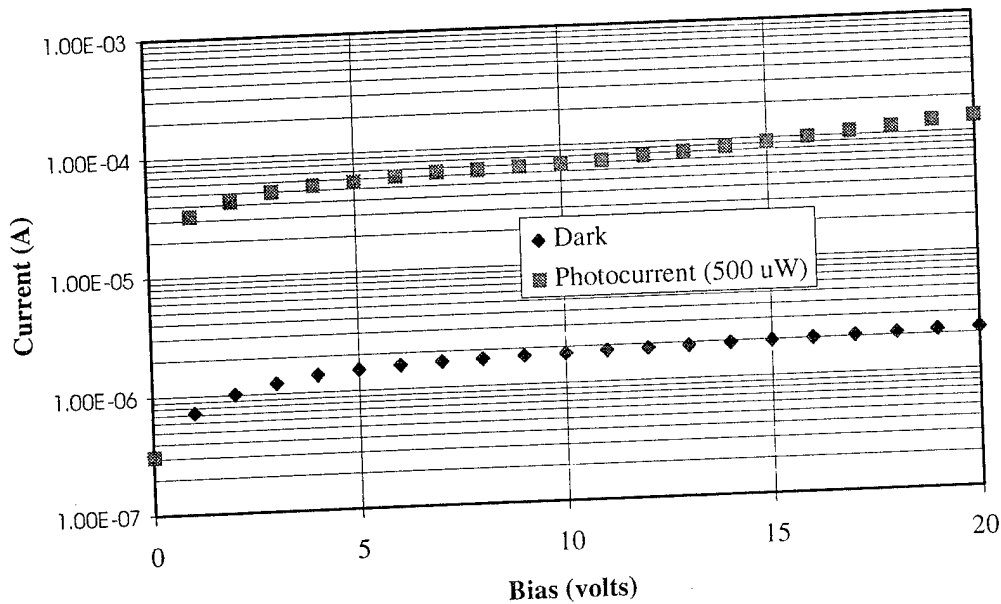

Figure 3. Mounted MSM DC Results

Two other devices were also mounted on a substrate that is inserted into a microwave test fixture to be used for the DC electron bombardment test. The two devices mounted were devices with electrode widths of 4 μm and spacing of 4 and 5 μm (W4G4 and W4G5) from the same wafer as the device mounted on the tube header as shown above. These two devices were bombarded with a beam of electrons using a scanning electron microscope. The microscope beam was expanded to cover the entire active area of the devices. Unfortunately both devices were shorted while attempting to determine the proper electron beam current and spot size. The test procedure is being reviewed and another set of devices will be mounted to test under electron bombardment.

Task III D

This task concerns the integration of an MSM device into the IPD and complete characterization of the prototype MSM-IPD. After optically characterizing the mounted

Contract #N00421-97-C-1204

Item 0003AC Final Option Period Report covering May 5, 1998 to August 5, 1998

Project title: Large Area, High Speed Photodiode using Metal-Semiconductor
Metal(MSM) Device

headers as discussed in task IIIC, the header was returned to Intevac, tested upon return to verify the device did not incur any damage during shipment, and used in the fabrication of the prototype. The prototype MSM-IPD fabricated consists of a 0.6 μm thickness GaAsP active layer photocathode and an MSM anode with a total area of 300 μm^2 with electrode width of 8 μm and gap of 4 μm .

In characterizing the MSM-IPD, various parameters were either measured or calculated from measured values. The parameters are as follows:

- photocathode dark current
- anode dark current
- MSM-IPD dark current
- photocathode quantum efficiency
- MSM-IPD responsivity
- gain
- signal/noise ratio
- noise equivalent power (NEP)
- detectivity (D^*)
- frequency response

The MSM-IPD operating parameters that are varied include:

- Anode bias : 1-15V
- Electron Beam Voltage: -2500, -5000, -6500, -8000 V
- Input optical power levels (DC): 25, 50, 75, 100, 250, 500, 750, 1000 nW

The first measurement taken was the MSM anode dark current which showed a significant change in behavior from the previously measured results. A comparison of dark current levels on the wafer, on the mounted IPD header, and in the MSM-IPD are shown in Figure 4. The data collected at the wafer levels shows complete symmetry with bias and a dark current level 1.25 μA at 15 volts which is a typical value for most of the same geometry MSMs measured on the same wafer. The MSM dark current was measured after the device was mounted on the substrate as shown in Figure 4. Although the

Contract #N00421-97-C-1204
 Item 0003AC Final Option Period Report covering May 5, 1998 to August 5, 1998
 Project title: Large Area, High Speed Photodiode using Metal-Semiconductor
 Metal(MSM) Device

symmetry is lost due to the asymmetry introduced by the substrate mounting technique, the value of dark current is similar to the wafer level devices at both bias polarities. Repeating the same measurement of the MSM anode after the IPD fabrication shows that the dark current for a positive applied bias is much smaller, 50 nA at +15V, compared to 0.26 μ A at -15V as indicated by the y-axis on the right of the chart.

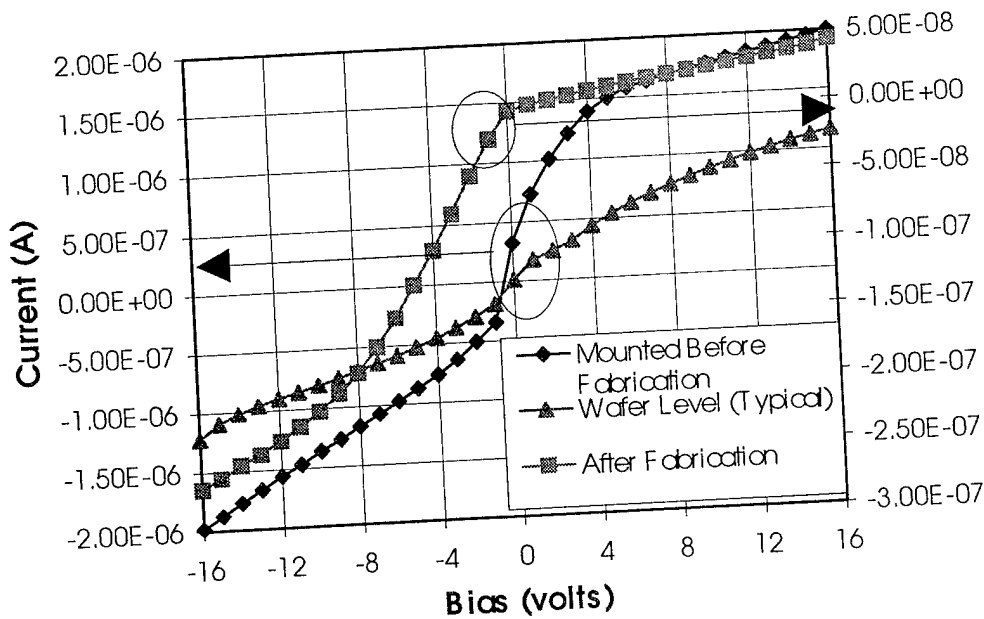

Figure 4. MSM Dark Current Comparison

During fabrication of the MSM-IPD, the phototube assembly is baked for an extended period of time at a high temperature. To determine if that could cause such a degradation in the MSM performance, the wafer level MSMs were subjected to the same conditions and indicated an increase in dark current from 1.12 μ A to 9.11 μ A at 15V and a decrease in photocurrent from 82.1 μ A to 63.4 μ A at 15V. Results of the temperature stress do not indicate that the baking process is responsible for the change in dark current and responsivity of the MSM.

Contract #N00421-97-C-1204

Item 0003AC Final Option Period Report covering May 5, 1998 to August 5, 1998

Project title: Large Area, High Speed Photodiode using Metal-Semiconductor Metal(MSM) Device

It is believed that the reason for the poor performance of the MSM anode is due to wire bonding technique used for the MSM planar electrode contact to the bottom conductive material. The wire bond connection could be open caused by a broken bond or wire during the baking process. This leads to a reduced current since the MSM essentially becomes a vertical device between the one top-side contact and the backside through the undoped and semi-insulating GaAs layers. This would also explain the asymmetry simply due to the contact differences of the top-side which is a titanium to undoped GaAs, while the bottom contact is gold to semi-insulating GaAs, leading to completely different barrier heights and dark current levels.

The static experimental results of the MSM-IPD is shown in Figure 5 with an electron energy of 8000 eV and MSM anode bias of 12V.

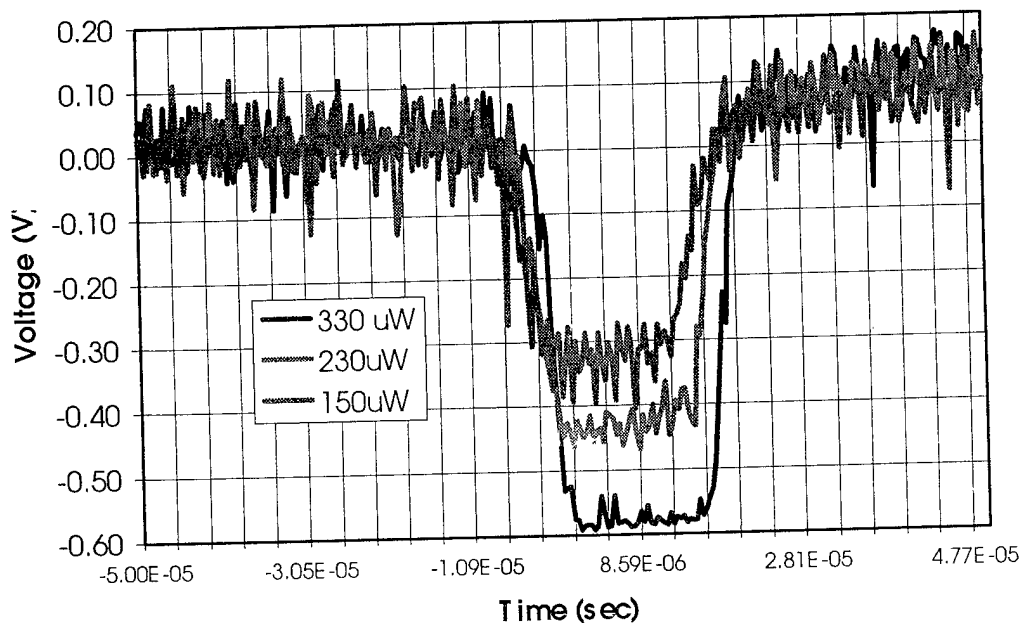

Figure 5. MSM-IPD Responsivity Data

Due to the damage incurred by the MSM during the fabrication process, the overall performance of the MSM-IPD was affected. A typical responsivity level of 100 A/W is

Contract #N00421-97-C-1204

Item 0003AC Final Option Period Report covering May 5, 1998 to August 5, 1998

Project title: Large Area, High Speed Photodiode using Metal-Semiconductor Metal(MSM) Device

expected for an electron energy of 8000 eV with optical power levels of a few nanowatts. As seen in Figure 5, the optical power levels needed to acquire an output signal were hundreds of microwatts with a responsivity of 0.2 A/W. The photocathode quantum efficiency of the MSM-IPD was good and measured to be 0.28, thereby further indicating the effect of the MSM anode on overall performance. The frequency response of the MSM-IPD is limited by the response of the MSM anode to 2.1 GHz. Table 1 gives a complete listing of the MSM-IPD performance.

Table 1. MSM-IPD Characterization Results

Photocathode Dark Current (nA)	0.58
Anode Dark Current (nA)	32.1
IPD Dark Current (nA)	41.1
Photocathode Quantum Efficiency	0.28
Responsivity (A/W)	0.163
Gain	1.8
S/N (dB)	NA
NEP(pW/√Hz)	5.7×10^3
D* (cm-Hz/W)	5.56×10^{11}
Bandwidth (GHz)	2.1

During a visit with Intevac, the MSM-IPD was cracked and confirmed that the wire bond is broken as hypothesized. Alternate options for MSM mounting were discussed with Intevac.

Task IV

Task IV involves applying a magnetic field in addition to the electric field to improve the electron beam focusing. No systematic procedure was used in improving the focus. For an IPD with a 0.3 mm Schottky diode anode, the addition magnetic field is necessary to acquire any signal. The IPD is manufactured using proximity focusing which means no attempt is made during the manufacturing process to determine the proper

Contract #N00421-97-C-1204

Item 0003AC Final Option Period Report covering May 5, 1998 to August 5, 1998

Project title: Large Area, High Speed Photodiode using Metal-Semiconductor
Metal(MSM) Device

placement of the anode to provide maximum coupling of the electron beam. An organic doughnut shaped magnet is used and proper placement of the magnet is done by trial and error.

Option Summary

The objective of the Option work plan was to fabricate a prototype MSM-IPD photodetector. This included the mounting of MSM devices, subsequent optical and electron beam characterization, and finally integration of the MSM as the anode of the IPD. The mounting and optical characterization of the MSM was successful, however the DC electron beam test did not produce any results since both MSM devices were shorted during the test procedure. A prototype MSM-IPD phototube was fabricated and characterized. During the characterization of the phototube, it was determined that the MSM anode had suffered some damage during the fabrication process, causing the poor response of the MSM-IPD. The phototube was cracked and clearly showed that the wire bond connection had broken during the baking process.

Phase II Work Plan

Representatives of F&H Applied Science Associates, Inc. and the Naval Air Warfare Center point-of-contact, Dr. V.M. Contarino visited the IPD manufacturer, Intevac, to discuss the work plan needed for a successful completion of Phase II. A custom MSM-IPD process flowchart was agreed upon by all parties. The flowchart is given below in Figure 6.

Results of the prototype MSM-IPD were shown and Intevac agreed to design a new style header to accommodate the planar structure of the MSM electrodes. Fabrication of development MSM anodes will be done by F&H Applied Science Associates, while the final 10 GHz design MSM will be fabricated in the Intevac cleanroom to increase the yield of the phototube.

Contract #N00421-97-C-1204

Item 0003AC Final Option Period Report covering May 5, 1998 to August 5, 1998

Project title: Large Area, High Speed Photodiode using Metal-Semiconductor Metal(MSM) Device

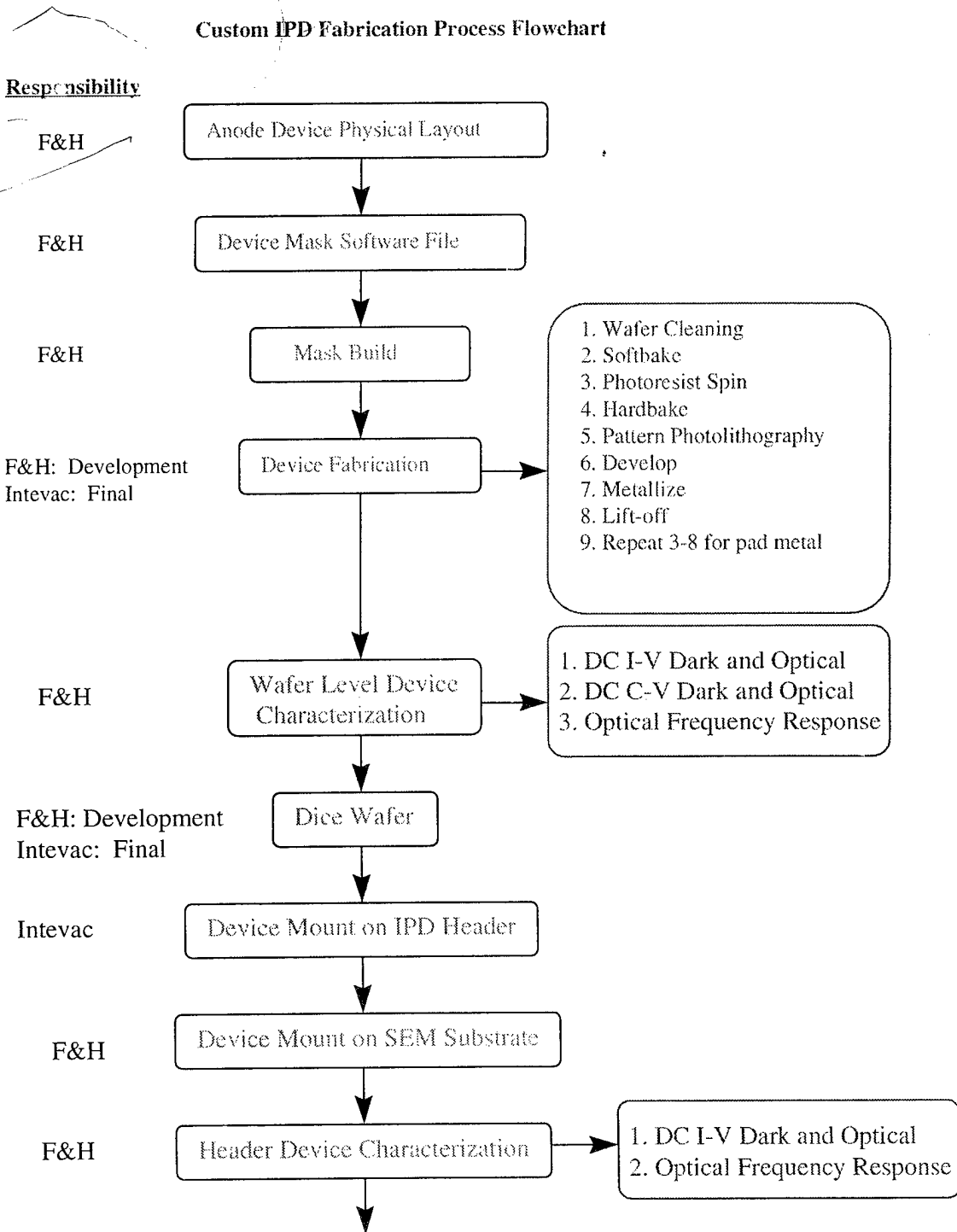

Figure 6. Custom IPD Process Flowchart

Contract #N00421-97-C-1204

Item 0003AC Final Option Period Report covering May 5, 1998 to August 5, 1998

Project title: Large Area, High Speed Photodiode using Metal-Semiconductor Metal(MSM) Device

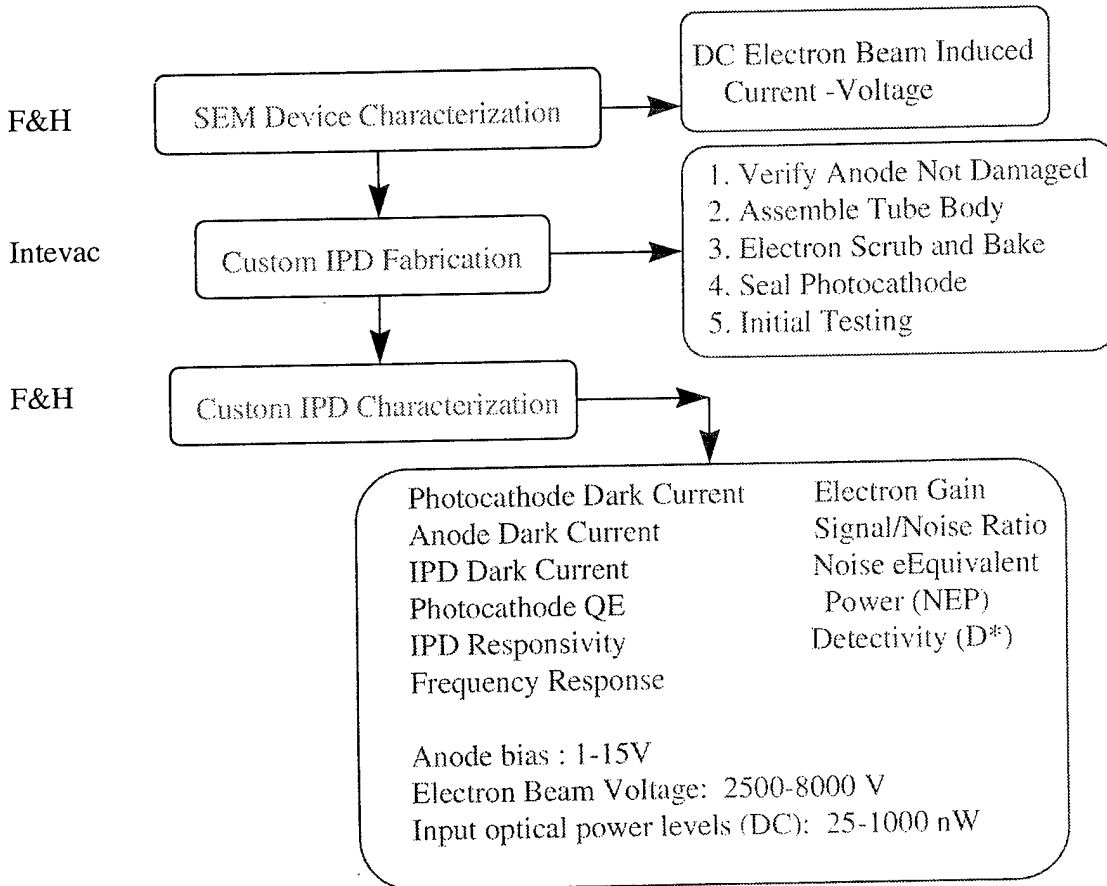

Figure 6 (cont). Custom IPD Process Flowchart

The result of the completed work, under Phase I and related Option toward Phase II, has shown promising results for the proof of concept demonstration of the novel high speed, large area photodetector. Furthermore we expect that under Phase II this new device will be completely developed. Since the need for higher and higher bandwidth devices in communication systems continues to grow, our device should find new applications in free-space optical communication links, improved Lidar applications,

Contract #N00421-97-C-1204

Item 0003AC Final Option Period Report covering May 5, 1998 to August 5, 1998

Project title: Large Area, High Speed Photodiode using Metal-Semiconductor
Metal(MSM) Device

spectroscopy, imaging, and various other applications where a large area, high speed photodetector with gain is essential.

References

- [1] R.A. LaRue, J.P. Edgecumbe, G.A. Davis, S. Gospe, V. Aebi, *SPIE Proceedings on Photodetectors and Power Meters*, vol. 2022, p. 64-73, 1993.
- [2] B.J. Van Zeghbroeck, W. Patrick, J. Halbout, P. Vettiger, *IEEE Trans. Electron Devices Letters*, vol. 9, p. 527- 529, 1988.