

ERDC/SL TR-00-5

Structures Laboratory



US Army Corps
of Engineers®
Engineer Research and
Development Center

Effects of an Anchoring Configuration on the Static Response of Geotextile and Geogrid Fabrics

Lebron Simmons

August 2000

DTIC QUALITY INSPECTED 4

20001025 010

The contents of this report are not to be used for advertising, publication, or promotional purposes. Citation of trade names does not constitute an official endorsement or approval of the use of such commercial products.

The findings of this report are not to be construed as an official Department of the Army position, unless so designated by other authorized documents.



PRINTED ON RECYCLED PAPER

ERDC/SL TR-00-5
August 2000

Effects of an Anchoring Configuration on the Static Response of Geotextile and Geogrid Fabrics

by Lebron Simmons

Waterways Experiment Station
U.S. Army Engineer Research and Development Center
3909 Halls Ferry Road
Vicksburg, MS 39180-6199

Final report

Approved for public release; distribution is unlimited

Prepared for U.S. Army Corps of Engineers
Washington, DC 20314-1000

and Defense Threat Reduction Agency
6801 Telegraph Road
Alexandria, VA 22310-3398

Engineer Research and Development Center Cataloging-in-Publication Data

Simmons, Lebron.

Effects of an anchoring configuration on the static response of geotextile and geogrid fabrics / by Lebron Simmons ; prepared for U.S. Army Corps of Engineers, Defense Threat Reduction Agency.

119 p. : ill. ; 28 cm. -- (ERDC/SL ; TR-00-5)

Includes bibliographic references.

1. Geotextiles -- Testing. 2. Geogrids -- Testing. I. Simmons, Lebron.
II. United States. Army. Corps of Engineers. III. U.S. Army Engineer Research and Development Center. IV. Structures Laboratory (U.S.) V. United States. Defense Threat Reduction Agency. VI. Title. VII. Series: ERDC/SL TR ; 00-5.
TA7 E8 no.ERDC/SL TR-00-5

Contents

Preface.....	xi
Acknowledgements.....	xii
1—Introduction.....	1
Background	1
Objective	2
Scope	3
2—Test Setup	4
Reaction Structure Details	4
Reaction Beam Design.....	4
Material Properties.....	7
Connection Design for Geotextile	8
Connection Design for Geogrid	8
Instrumentation	10
Photography.....	10
Experimental Procedure.....	10
3—Test Results.....	15
Group A Test 1	16
Group A Test 2.....	17
Group A Test 3.....	17
Group A Test 6.....	17
Group A Test 7.....	17
Group A Test 8.....	17
Group A Test 9.....	18
Group A Test 11.....	18
Group A Test 12.....	18
Group A Test 13.....	18
Group A Test 14.....	19
Group B Test 4.....	19
Group B Test 5.....	19
Group B Test 10.....	19

4—Analyses and Discussion of Experimental Results.....	34
Failure Modes.....	34
Failure Mode 1, Group A.....	34
Failure Mode 1, Group B.....	35
Failure Mode 2, Group A.....	35
Failure Modes 1 and 3, Group A.....	35
Failure Modes 1 and 3, Group B.....	36
ASTM Tests Versus Experimental Results.....	36
Group A.....	36
Group B.....	37
5—Summary, Conclusions, and Recommendations.....	39
Summary.....	39
Conclusions.....	39
Recommendations.....	40
Bibliography.....	42
Appendix A: Pressure and Deflection Plots.....	A1
Appendix B: ASTM 4595 Manufacturers Material Properties.....	B1
Appendix C: ASTM 4595 Material Properties.....	C1
SF 298	

List of Figures

Figure 1.1 Proposed prototype retrofit system.....	2
Figure 2.1 Experimental setup that models prototype system.....	5
Figure 2.2 Reaction Structure Cross-Section View.....	5
Figure 2.3 Reaction Structure Plan View.....	6
Figure 2.4 Detailed Design of Concrete Beams.....	6
Figure 2.5 Completed Concrete Beams.....	7
Figure 2.6 Connection Details for Geogrid/Geotextile.....	8
Figure 2.7 Typical pretest view of geotextile connection.....	9

Figure 2.8	Typical pretest view of the geogrid connection.....	9
Figure 2.9	Instrumentation gage layout.....	10
Figure 2.10	Empty reaction structure	11
Figure 2.11	The reaction beams during the placement process.....	12
Figure 2.12	Typical test setup.....	12
Figure 2.13	The sand is in place with small layers of neoprene.....	13
Figure 2.14	Typical test setup with the O-ring in place.....	13
Figure 2.15	The top was placed over the test chamber	14
Figure 2.16	The test chamber was cabled into position.....	14
Figure 3.1	Group A test 1 pretest	20
Figure 3.2	Group A test 1 posttest.....	20
Figure 3.3	Group A test 2 pretest	21
Figure 3.4	Group A test 2 posttest.....	21
Figure 3.5	Group A test 3 pretest	22
Figure 3.6	Group A test 3 posttest.....	22
Figure 3.7	Group B test 4 pretest.....	23
Figure 3.8	Group B test 4 posttest.....	23
Figure 3.9	Group B test 5 pretest.....	24
Figure 3.10	Group B test 5 posttest.....	24
Figure 3.11	Group A test 6 pretest	25
Figure 3.12	Group A test 6 posttest.....	25
Figure 3.13	Group A test 7 pretest	26
Figure 3.14	Group A test 7 posttest.....	26
Figure 3.15	Group A test 8 pretest	27
Figure 3.16	Group A test 9 pretest	28

Figure 3.17	Group A test 9 posttest.....	28
Figure 3.18	Group B test 10 pretest.....	29
Figure 3.19	Group B test 10 posttest.....	29
Figure 3.20	Group A test 11 pretest	30
Figure 3.21	Group A test 11 posttest.....	30
Figure 3.22	Group A test 12 pretest	31
Figure 3.23	Group A test 12 posttest.....	31
Figure 3.24	Group A test 13 pretest	32
Figure 3.25	Group A test 13 posttest.....	32
Figure 3.26	Group A test 14 pretest	33
Figure 3.27	Group A test 14 posttest.....	33
Figure A.1	Group A test 1 P1 pressure versus D1 deflection plot	A2
Figure A.2	Group A test 1 P1 pressure versus D2 deflection plot	A2
Figure A.3	Group A test 1 P1 pressure versus D3 deflection plot	A2
Figure A.4	Group A test 1 P1 pressure versus D4 deflection plot	A2
Figure A.5	Group A test 2 P1 pressure versus D1 deflection plot	A3
Figure A.6	Group A test 2 P1 pressure versus D2 deflection plot	A3
Figure A.7	Group A test 2 P1 pressure versus D3 deflection plot	A3
Figure A.8	Group A test 2 P1 pressure versus D4 deflection plot	A3
Figure A.9	Group A test 3 P1 pressure versus D1 deflection plot	A4
Figure A.10	Group A test 3 P1 pressure versus D2 deflection plot	A4
Figure A.11	Group A test 3 P1 pressure versus D3 deflection plot	A4
Figure A.12	Group A test 3 P1 pressure versus D4 deflection plot	A4
Figure A.13	Group B test 4 P2 pressure versus D1 deflection plot	A5
Figure A.14	Group B test 4 P2 pressure versus D3 deflection plot	A5

Figure A.15	Group B test 4 P2 pressure versus D4 deflection plot	A5
Figure A.16	Group B test 5 P1 pressure versus D1 deflection plot	A6
Figure A.17	Group B test 5 P1 pressure versus D2 deflection plot	A6
Figure A.18	Group B test 5 P1 pressure versus D3 deflection plot	A6
Figure A.19	Group B test 5 P1 pressure versus D4 deflection plot	A6
Figure A.20	Group A test 6 P1 pressure versus D1 deflection plot	A7
Figure A.21	Group A test 6 P1 pressure versus D2 deflection plot	A7
Figure A.22	Group A test 6 P1 pressure versus D3 deflection plot	A7
Figure A.23	Group A test 7 P1 pressure versus D1 deflection plot	A8
Figure A.24	Group A test 7 P1 pressure versus D2 deflection plot	A8
Figure A.25	Group A test 7 P1 pressure versus D3 deflection plot	A8
Figure A.26	Group A test 7 P1 pressure versus D4 deflection plot	A8
Figure A.27	Group A test 8 P1 pressure versus D1 deflection plot	A9
Figure A.28	Group A test 8 P1 pressure versus D2 deflection plot	A9
Figure A.29	Group A test 8 P1 pressure versus D4 deflection plot	A9
Figure A.30	Group A test 9 P1 pressure versus D2 deflection plot	A10
Figure A.31	Group A test 9 P1 pressure versus D3 deflection plot	A10
Figure A.32	Group A test 9 P1 pressure versus D4 deflection plot	A10
Figure A.33	Group B test 10 P1 pressure versus D2 deflection plot	A11
Figure A.34	Group B test 10 P1 pressure versus D3 deflection plot	A11
Figure A.35	Group B test 10 P1 pressure versus D4 deflection plot	A11
Figure A.36	Group A test 11 P1 pressure versus D1 deflection plot	A12
Figure A.37	Group A test 11 P1 pressure versus D3 deflection plot	A12
Figure A.38	Group A test 11 P1 pressure versus D4 deflection plot	A12
Figure A.39	Group A test 12 P1 pressure versus D1 deflection plot	A13

Figure A.40	Group A test 12 P1 pressure versus D2 deflection plot	A13
Figure A.41	Group A test 12 P1 pressure versus D3 deflection plot	A13
Figure A.42	Group A test 12 P1 pressure versus D4 deflection plot	A13
Figure A.43	Group A test 13 P2 pressure versus D1 deflection plot	A14
Figure A.44	Group A test 13 P2 pressure versus D2 deflection plot	A14
Figure A.45	Group A test 13 P2 pressure versus D3 deflection plot	A14
Figure A.46	Group A test 13 P2 pressure versus D4 deflection plot	A14
Figure A.47	Group A test 14 P1 pressure versus D1 deflection plot	A15
Figure A.48	Group A test 14 P1 pressure versus D2 deflection plot	A15
Figure A.49	Group A test 14 P1 pressure versus D3 deflection plot	A15
Figure A.50	Group A test 14 P1 pressure versus D4 deflection plot	A15
Figure C.1	ASTM 4595 Group A GT 600 machine direction.....	C30
Figure C.2	ASTM 4595 Group A GT 600 cross direction	C30
Figure C.3	ASTM 4595 Group A GT 800 machine direction.....	C31
Figure C.4	ASTM 4595 Group A GT 800 cross direction	C31
Figure C.5	ASTM 4595 Group A GT 1715 machine direction.....	C32
Figure C.6	ASTM 4595 Group A GT 1715 cross direction	C32
Figure C.7	ASTM 4595 Group B GG 10 machine direction.....	C33
Figure C.8	ASTM 4595 Group B GG 10 cross direction	C33
Figure C.9	ASTM 4595 Group B GG 24 machine direction.....	C34
Figure C.10	ASTM 4595 Group B GG 24 cross direction	C34
Figure C.11	ASTM 4595 Group A COM GT 350 machine direction	C35
Figure C.12	ASTM 4595 Group A COM GT 350 cross direction.....	C35
Figure C.13	ASTM 4595 Group A COM GT 500 machine direction	C36
Figure C.14	ASTM 4595 Group A COM GT 500 cross direction.....	C36

Figure C.15	ASTM 4595 Group A K 1084 machine direction	C37
Figure C.16	ASTM 4595 Group A K 1084 cross direction.....	C37
Figure C.17	ASTM 4595 Group B GG 1500 machine direction	C38
Figure C.18	ASTM 4595 Group B GG 1500 cross direction.....	C38

List of Tables

Table 1.1	Static Response of Geotextile and Geogrid Fabrics Test Matrix	3
Table 2.1	Material Properties	7
Table 3.1	General Test of Geogrid/Geotextile Connection Systems.....	15
Table 3.2	Deflection Profile at Peak Pressure	16
Table 3.3	Test Results in Terms of Failure Modes.....	16
Table 4.1	Experimental Results Versus ASTM 4595 and Fabric's Ultimate Strength	34
Table C.1	ASTM 4595 Group A GT 600 Machine Direction	C13
Table C.2	ASTM 4595 Group A GT 600 Cross Direction	C14
Table C.3	ASTM 4595 Group A GT 800 Machine Direction	C15
Table C.4	ASTM 4595 Group A GT 800 Cross Direction	C16
Table C.5	ASTM 4595 Group A GT 1715 Machine Direction	C17
Table C.6	ASTM 4595 Group A GT 1715 Cross Direction	C18
Table C.7	ASTM 4595 Group B GG 10 Machine Direction	C19
Table C.8	ASTM 4595 Group B GG 10 Cross Direction	C20
Table C.9	ASTM 4595 Group B GG 24 Machine Direction	C21
Table C.10	ASTM 4595 Group B GG 24 Cross Direction	C22
Table C.11	ASTM 4595 Group A COM GT 350 Machine Direction	C23
Table C.12	ASTM 4595 Group A COM GT 350 Cross Direction	C24

Table C.13	ASTM 4595 Group A COM GT 500 Machine Direction	C25
Table C.14	ASTM 4595 Group A COM GT 500 Cross Direction	C26
Table C.15	ASTM 4595 Group A K 1084 Machine Direction	C27
Table C.16	ASTM 4595 Group A K 1084 Cross Direction	C28
Table C.17	ASTM 4595 Group B GG 1500 Machine Direction	C29

Preface

The research reported herein was sponsored by the U.S. Army. The work was performed in connection with ongoing research on survivability and protective structures.

The research effort was conducted during the period October 1997 to January 1998. The work was carried out by Mr. Lebron Simmons, Structural Mechanics Division (SMD), Structures Laboratory (SL), U.S. Army Engineer Research and Development Center (ERDC), under general supervision of Dr. Michael J. O'Connor, Acting Director, SL; Dr. Bryant Mather, Director Emeritus, SL; Dr. Reed Mosher, Chief, SMD, SL; Dr. Stanley Woodson, SMD, SL; and Mr. David Coltharp, Research Physicist, SMD, SL. Other personnel who contributed to this study were Messrs. Clay Hooker, Contractor, MEVATEC Corporation, and Charles Thompson, Instrumentation Systems Development Division, Information Technology Laboratory, ERDC. This research was conducted and the report was written by Mr. Simmons in partial fulfillment of the requirements for his M.S. thesis in Civil Engineering from Mississippi State University, Mississippi State, MS.

At the time of publication of this report, Director of ERDC was Dr. James R. Houston, and Commander was COL James S. Weller, EN.

Acknowledgements

The author would like to acknowledge his sincere gratitude to the many people involved in the research contained herein and in the preparation of this thesis. My committee chairman, Dr. R. Ralph Sinno, is thanked for his assistance in guiding me through the thesis process. The other members of the committee, Dr. David H. Huddleston, Dr. Stanley Woodson, and Dr. Oswald Herrero-Rendon, are all thanked for their invaluable aid and guidance. Thanks are also due to Mr. Ray Glarrusso of GEO-CIV Products for his assistance with the geotextile and geogrid materials. The research that formed the basis of this thesis was sponsored by the U.S. Army and was conducted at the Structural Mechanics Division (SMD), Structures Laboratory (SL), U.S. Army Engineer Research and Development Center (ERDC), Vicksburg, MS. Special thanks are extended to Dr. Stanley Woodson for his onsite support and assistance to make this research possible, as well as to Dr. Bryant Mather, Director Emeritus, SL, Dr. Reed Mosher, Chief, SMD, SL, and Mr. David Coltharp, Research Physicist, SMD, SL.

1 Introduction

Background

Events such as the World Trade Center Bombing in 1993, the Oklahoma City Bombing in 1994, and the Kobar Towers Bombing in 1996 graphically demonstrated the effects of vehicle bombs on conventional structures. Not only have such incidents occurred at locations where military troops and their families are stationed throughout the world, but also within our nation's cities.

Obviously, close-in detonations against primary structural components, such as columns and beams, can produce catastrophic failures and progressive collapse. Catastrophic failure can result in large a number of fatalities. However, another effect of the blast impinging on the structure is the creation of debris. In addition to windows and wall fragments, debris may include flying objects from ceilings and furniture.

A primary construction technique for low-rise structures throughout the world is that of reinforced concrete or steel frame construction with in-fill brick or concrete masonry unit (CMU) wall panels. Although the blast-resistant masonry panels may vary depending on construction details, the blast resistance of such walls will seldom exceed about 10 pounds per square inch (psi). In contrast, reflected blast pressure on walls as a result of vehicle bombs' detonations may be several thousand psi, depending on the explosive charge weight and the bomb standoff. Consequently, failure of masonry walls may be expected. Also, the significant overload of the wall will result in high-velocity fragments and debris that will damage interior property and cause severe injury and human fatalities.

The Department of Defense has initiated studies to develop retrofit systems to reduce the hazard levels of masonry panels. Figure 1.1 shows a proposed prototype retrofit system. Full-scale dynamic field experiments are planned. Since full-scale experiments are costly, it is important that such experiments are carefully planned. One approach is to conduct smaller laboratory experiments in order to develop and screen potential retrofit techniques, thereby assisting in the design of the full-scale experiments. The use of geogrid or geotextile materials, anchored to the structural frame of the building to catch the flying masonry debris has been identified as a viable solution. The static experiments discussed

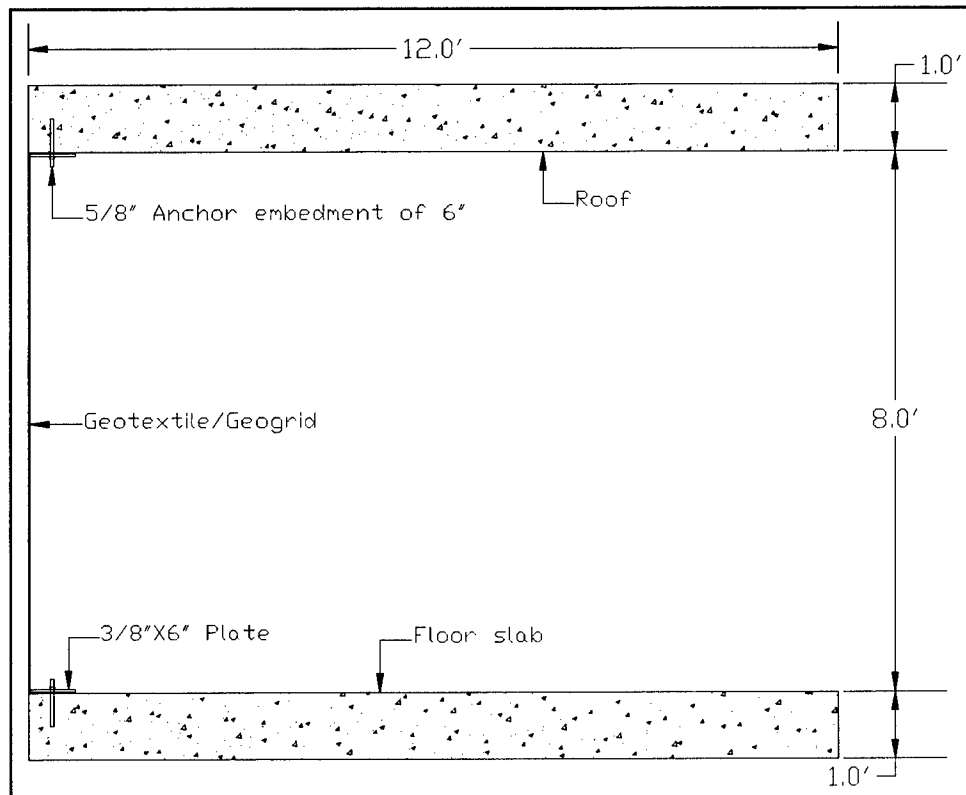

Figure 1.1. Proposed prototype retrofit system

herein constitute a first and significant step in the development of retrofit systems for masonry panels.

Objective

The objective of the experiments was to evaluate the performance of a retrofit system that consists of geotextile and geogrid materials anchored to reinforced concrete beams. For the purpose of presentation and discussion, the geotextiles were arranged in Group A, and the geogrids were placed in Group B. The ultimate capacity and large-deflection behavior of these retrofit systems were determined. A critical issue regarding retrofit systems is the development of practical and effective techniques for anchoring the geotextile and geogrid materials to the reinforced concrete beams and slabs of a structure. Thus, the primary purpose of this thesis is to develop a connection design with anchors, geotextile, and geogrid materials to reduce the hazard of wall-debris fragments. Based on the experimental results, recommendations will be made for the application of the systems to be used for existing structures. The primary application of the research results will be to retrofit panel walls of reinforced concrete structures in order to reduce fragment hazards. The main emphasis of this thesis will be the development and evaluation of techniques for anchoring the material at the reinforced concrete supports.

Scope

Fourteen static tests were conducted by slowly increasing the uniform load (water pressure) in the 6-ft-diameter static chamber in the Structural Dynamics Test Facility at WES. The test device used in these experiments includes a high-pressure pump, which is needed to obtain the desired pressure for the uniform load. The reinforced concrete beams were designed to represent sections of roof and floor slabs in a reinforced concrete building. The experiment configuration consisted of two concrete beams fixed to a steel reaction structure with geotextile or geogrid material anchored to and spanning between the beams. The beams' dimensions were 5.5-in. wide by 30.3-in. long and 9.0-in. thick. Grade 60 steel rebar and 4,000-psi concrete (3/8-in. aggregate diameter) were used in the beams. The design of the beam included principal steel reinforcement ratios of approximately 0.005 in each face. Several types of geotextile/geogrid material were selected with tensile strength ranging from 600 lb/in. to 3,000 lb/in. The test series investigated the effect of the different tensile strength of the materials and demonstrated the load resistance of the lighter-to-heavier materials. The vendors' products used in this test series were from the Mirafi, Huesker, and Tensar Corporations. The expansive anchors used in this series were manufactured by Hilti. The spacing of the anchors was 5 inches on center for each test, and the anchors' diameter was based on the strength of the geotextile and geogrid materials. The test matrix (in order of testing) for the test series is shown in Table 1.1.

Table 1.1
Static Response of Geotextile and Geogrid Fabrics Test Matrix

Test No.	Material Category	Specimen Label	Anchor Bolt Diameter (in.)	Anchor Bolt Spacing (in.)	Anchor Bolt Embedment (in.)	Plate Dimension (in.)
1	Group A	GT 600-A	0.375	5	3.625	0.25x4x32
2	Group A	GT 800-A	0.375	5	3.625	0.25x4x32
3	Group A	GT 1715-A	0.5	5	3.75	0.25x4x32
4	Group B	GG 10	0.375	5	3.625	0.25x4x32
5	Group B	GG 24	0.5	5	4.0	0.25x4x32
6	Group A	GT 600-B	0.375	5	3.625	0.25x4x32
7	Group A	GT 1715-B	0.5	5	4.0	0.25x4x32
8	Group A	Com GT 350-A	0.625	5	4.125	0.375x4x32
9	Group A	Com GT 350-B	0.625	5	4.125	0.25x4x32
10	Group B	GG 1500	0.375	5	3.625	0.25x4x32
11	Group A	K 1084	0.5	5	3.75	0.25x4x32
12	Group A	GT 800-B	0.375	5	3.625	0.25x4x32
13	Group A	Com GT 350-C	0.625	5	4.125	0.375x4x32
14	Group A	Com GT 500	0.625	5	4.125	0.375x4x32

Note:

GT 600: High-Strength Geotextile Fabric, 600 lb/in. tensile strength.

GG 10: Geogrid 10 XT, XT refers to manufacturer's product identification.

Com GT 350: Comtrac Geotextile, 350 kn/m tensile strength.

K: Kelvar material, 1,084 lb/in. tensile strength.

A, B, and C in the specimen label: Refers to separate experiments on a material type.

Group A: Geotextile

Group B: Geogrid

2 Test Setup

The experiments were conducted in the 6-ft-diameter static chamber in the Structural Dynamics Test Facility at WES during the period October 1997-January 1998. Figure 2.1 is a schematic drawing of the experimental setup designed to represent the prototype. The following sections describe the reaction structure details, reaction beam design, material properties, connection design for the Geotextile and the Geogrid, instrumentation, photography, and the experimental procedure.

Reaction Structure Details

The reaction structure was constructed during previous experimental slab studies and adopted for this series. Figures 2.2 and 2.3 show the cross-sectional and plan view details of the reaction structure. It is essentially a steel box with concrete-filled end walls. The reaction structure allows a concrete beam to be anchored at each end of the box, leaving a clear span of 36 inches for the geotextile or geogrid to the span. Steel wedges can be bolted into position against the concrete beams, restricting rotation of the beams.

Reaction Beam Design

Reinforced concrete beams were anchored to the reaction structure to represent the floor slabs of the building. The reinforced concrete beams were designed with a 28-day design compressive strength of 4,000 psi. The reinforcement steel ratio was approximately 0.005 in each face, and No. 3 Grade 60 rebar was used in the beams. The concrete beams included shear stirrups that were fabricated from D2 deformed wire that was heat-treated to simulate Grade 60 rebar. The spacing of the rebars and stirrups was approximately 5 inches on center. The two reinforced concrete beams were designed to withstand the reactions from a test specimen subjected to over 200 psi. Figure 2.4 shows the detailed design of the concrete beams. Figure 2.5 shows the completed concrete beams.

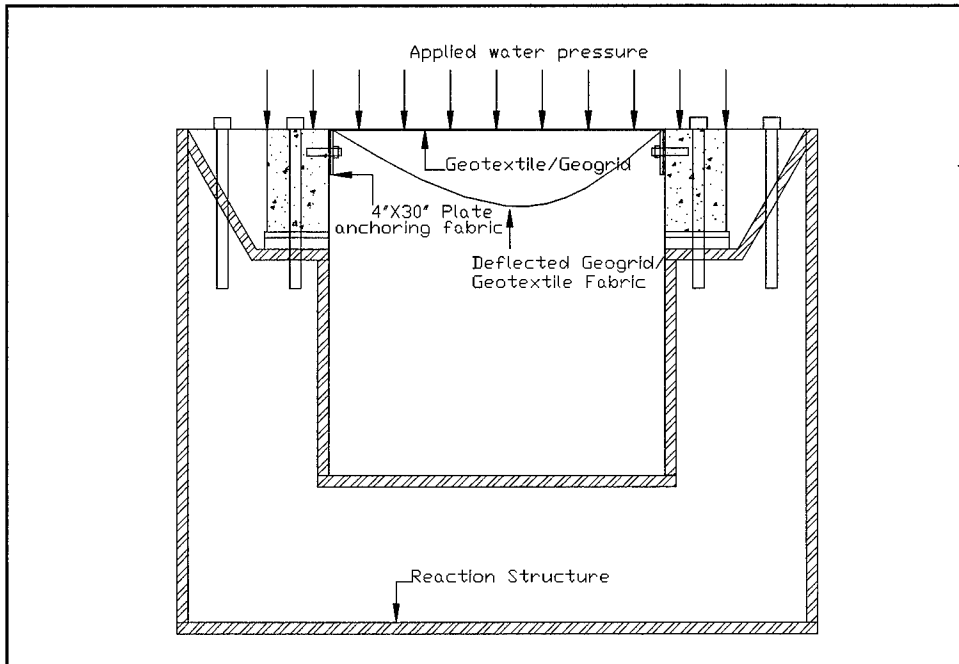

Figure 2.1. Experimental setup that models prototype system

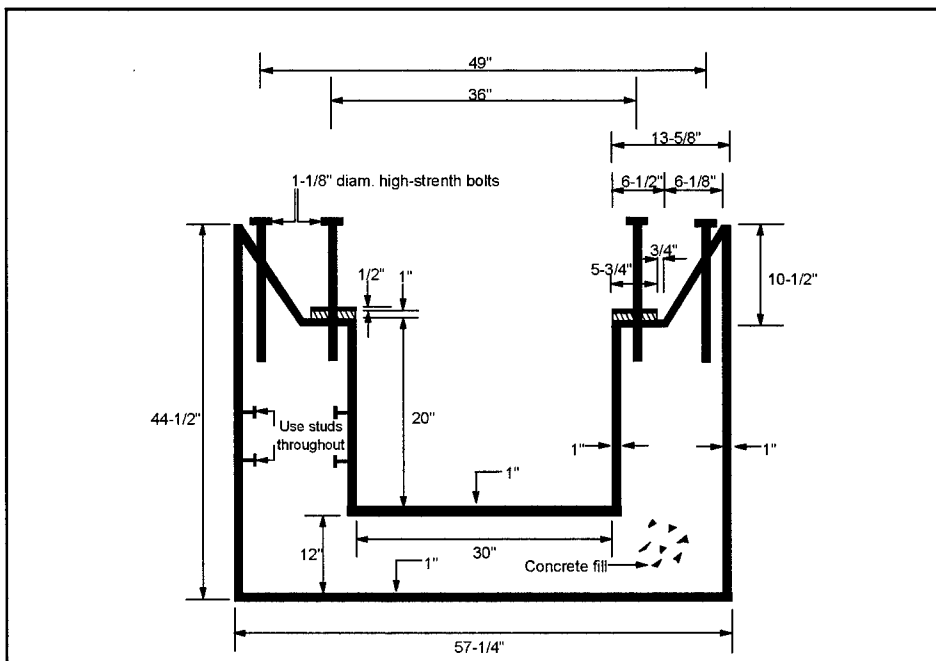

Figure 2.2. Reaction Structure Cross-Section View

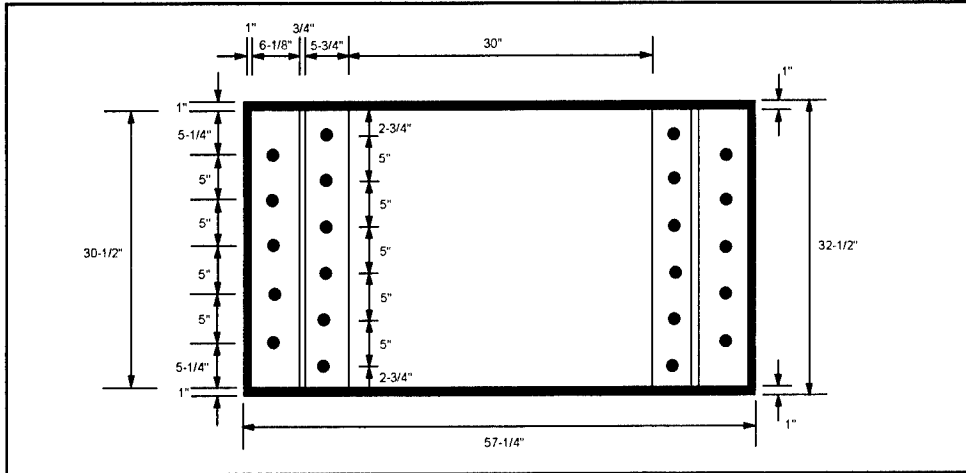

Figure 2.3. Reaction Structure Plan View

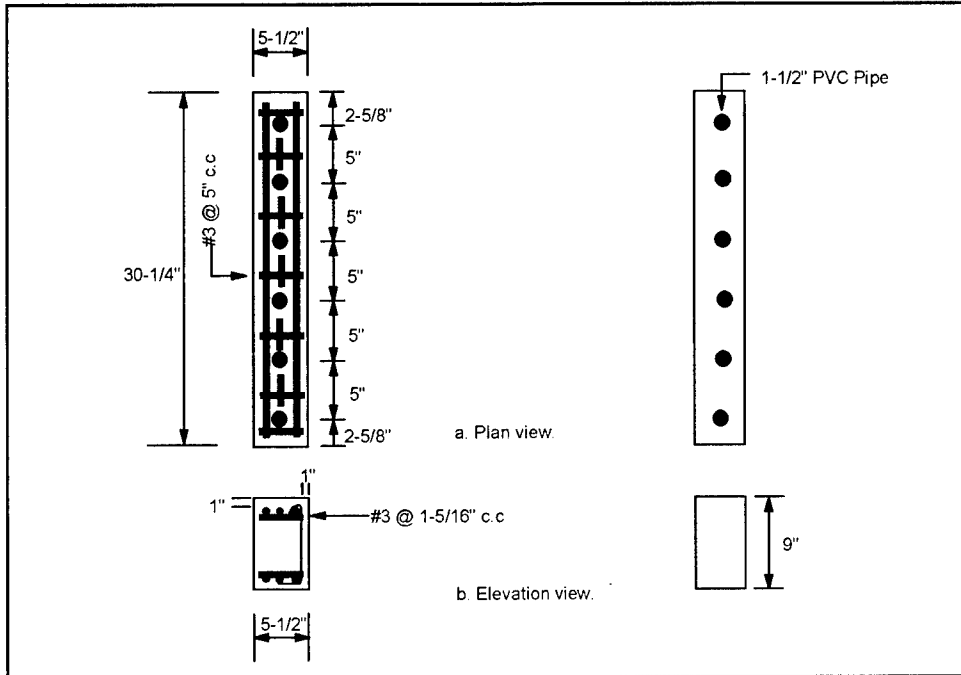

Figure 2.4. Detailed design of Concrete Beams



Figure 2.5. Completed concrete beams

Material Properties

Several types of geotextile and geogrid materials were selected, with tensile strength ranging from 600 lb/in. to 3,000 lb/in. The vendors of the products used in this test series were Mirafi, Huesker, and Tensar. The materials were selected based on strength, unit weight, and cost. Table 2.1 presents the primary material properties for these experiments. The ultimate strengths obtained from the vendors are presented in Appendix C. The material properties were determined in this study in accordance with the American Society Testing Material 4595 and are listed in Appendix D.

Table 2.1 Material Properties					
Material Category	Test No.	Specimen Label	Tensile Strength (at ultimate) Machine Direction (lb/in.)	Tensile Strength (at ultimate) Cross Ma. Direction (lb/in.)	Mass/Unit Area oz/sq.yard
Group A	1	GT 600-A	600	450	12.0
Group A	2	GT 800-A	800	550	15.1
Group A	3	GT 1715-A	1715	600	27.7
Group A	6	GT 600-B	600	450	12.0
Group A	7	GT 1715-B	1715	600	27.7
Group A	8	Com GT 350-A	1995	715	25.0
Group A	9	Com GT 350-B	1995	715	25.0
Group A	11	K 1084	1084	N/A	10.1
Group A	12	GT 800-B	800	550	15.1
Group A	13	Com GT 350-C	1995	715	25.0
Group A	14	Com GT 500	2885	400	30.0
Group B	4	GG 10	658	175	12.1
Group B	5	GG 24	2115	217	33.0
Group B	10	GG 1500	575	N/A	16.0

Connection Design for Geotextile

The connection design for the geotextile fabrics was based on the vendors' published strengths of the materials. Figure 2.6 shows the connection design for the test series. Figure 2.7 shows a typical pretest view of the geotextile connection. The geotextile tensile strengths were in the range of 600 lb/in. to 3,000 lb/in. The lighter geotextile fabrics in the 600-lb/in. to 800-lb/in. tensile strength range were connected to the beams with 0.375-in.-diameter anchors and two 0.25-in.-thick plates. The geotextile, with a tensile strength in the 1,000-lb/in. range, was attached with diameter anchors 0.5-in. and 0.25-in.-thick plates. The connection detail for the geotextiles included a 0.125-in. thick layer of neoprene rubber installed between the plate and the material. The geotextile fabric in the 2,000-lb/in. range were connected to the beams with 0.625-in. diameter anchors and 0.375-in. thick plates. The spacing for all the anchors was 5 inches on center.

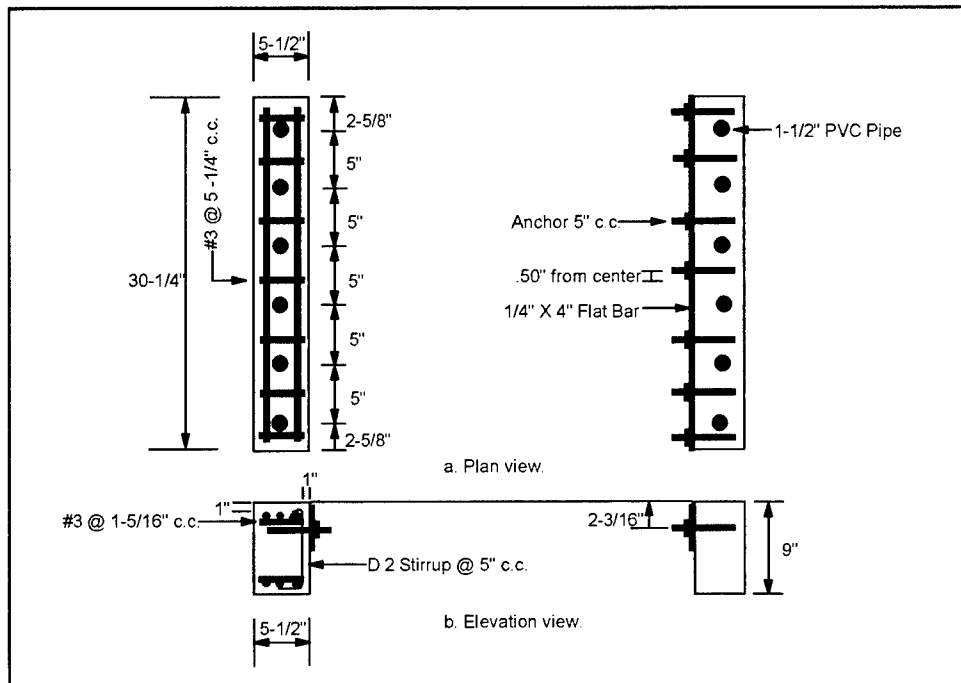

Figure 2.6. Connection details for geogrid/geotextile

Connection Design for Geogrid

The connection design for the geogrid materials was similar to that of the geotextile. Only three geogrids were tested in this series. Figure 2.6 also shows the connection design for the geogrids. Figure 2.8 shows a typical pretest view of the geogrid connection. Two geogrids were in the 600-lb/in. tensile strength range. The geogrids were anchored with 0.375-in.-diameter anchors and 0.25-in.-thick plates. The connection for geogrids also included a 0.125-in.-thick layer of neoprene rubber installed between the plate and the material. This design concept was used to reduce the pullout of the fabrics. The geogrid in the

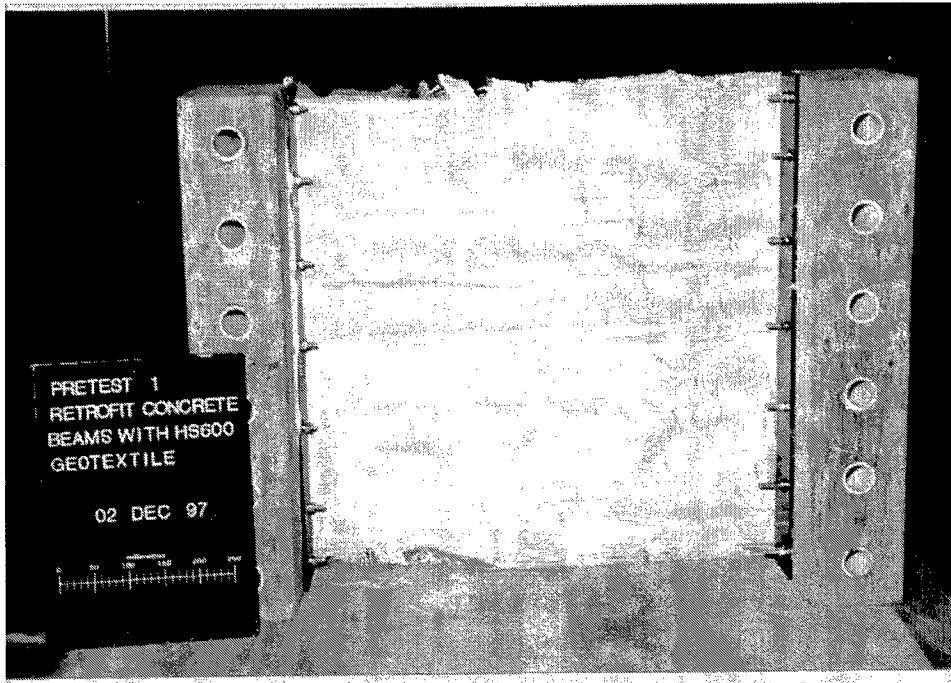

Figure 2.7. Typical pretest view of geotextile connection

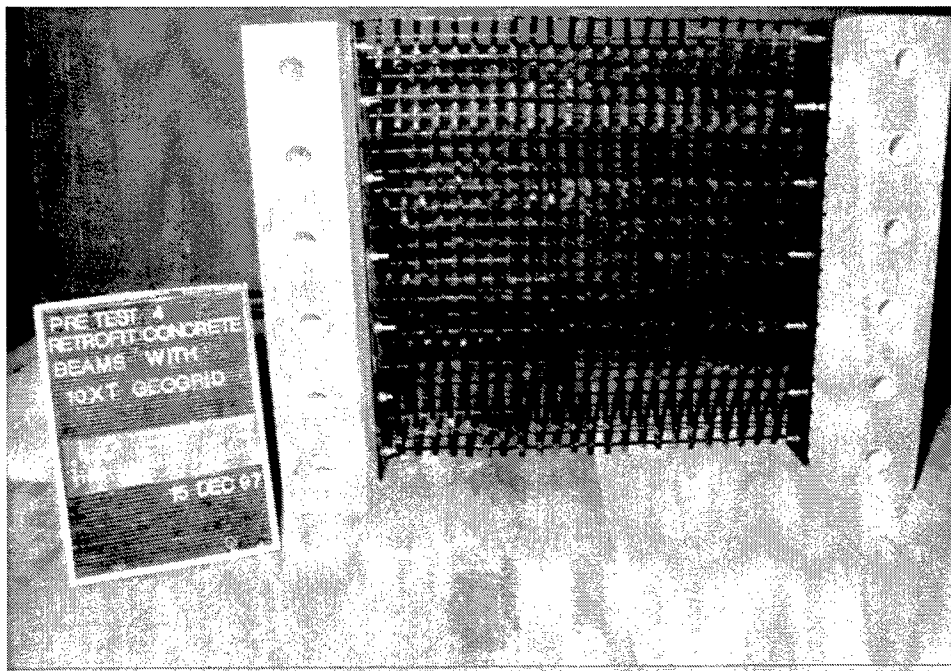

Figure 2.8. Typical pretest view of the geogrid connection

2,000-lb/in. tensile strength range was anchored with 0.50-in.-diameter anchors and two 0.25-in.-thick plates. The spacing of the anchors was 5 inches on center for each anchor design.

Instrumentation

Each specimen was instrumented for displacement and pressure measurements. The data were recorded on a Pacific Transit data recorder, and digitized and plotted by computer. Figure 2.9 shows a typical gage location. Four displacement transducers were used in each test to measure vertical displacement. The deflection gages were located along the centerline at midspan and the quarter point, as well as near the edge at midspan. The transducers used were Trans-PT Model 8101-0020, having a range of 20.00 inches. The gages were installed on the geotextile and geogrid materials.

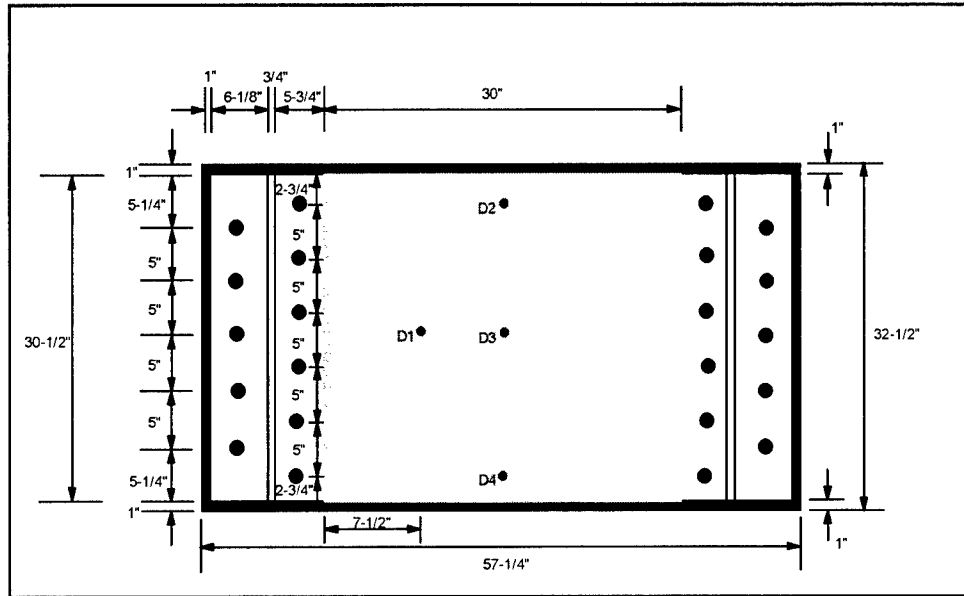

Figure 2.9. Instrumentation gage layout

Two Kulite Model HKM-S375, 500-psi range pressure gages (P1) and (P2) were mounted in the top of the test chamber in order to measure the water pressure applied to the materials. Since the pressure measurements for (P1) and (P2) were identical, only the data from one gage are presented in this thesis.

Photography

Pre- and posttest photographs, slides, and video coverage documented each test. Photographic coverage was also provided during the construction and installation phases.

Experimental Procedure

The experimental procedure involved the uniform loading (slowly increasing water pressure) of the geotextile and geogrid fabrics to investigate the load-deflection behavior of the material specimens and related connection systems.

The experimental procedure began with an empty reaction structure, shown in Figure 2.10. Figure 2.11 shows the reaction beams during the placement process. Figure 2.12 shows a typical test setup with the material and beams bolted in place. Sand was used to fill the test chamber voids outside of the reaction structure. Figure 2.13 shows the sand in place with 8-inch wide strips of neoprene rubber around the fabric to protect the loading membrane from the edges of the steel structure. Two layers 0.125-in. thick of neoprene rubber (loading membrane) were placed over the entire cross section of test chamber, and a 1-in.-thick by 60-in.-diameter steel ring with a rubber O-ring was bolted into position as shown in Figure 2.14 to seal the cross section. The top was placed over the test chamber as shown in Figure 2.15, and the test chamber was cabled into position as shown in Figure 2.16. The test chamber volume above the neoprene layer was then filled with water, requiring approximately 30 minutes. The engineer then directed the instrumentation technician and pump operator to begin the loading of the connection system. The engineer monitored the pressure and deflection data inside the instrumentation room and decided when to terminate the experiment.



Figure 2.10. Empty reaction structure



Figure 2.11 The reaction beams during the placement process

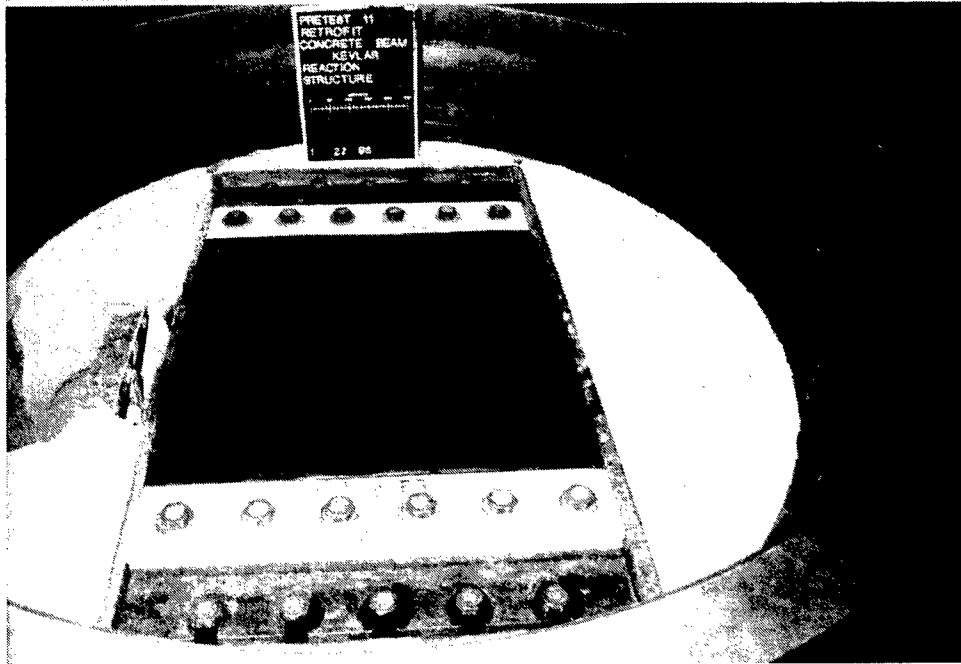

Figure 2.12. Typical test setup

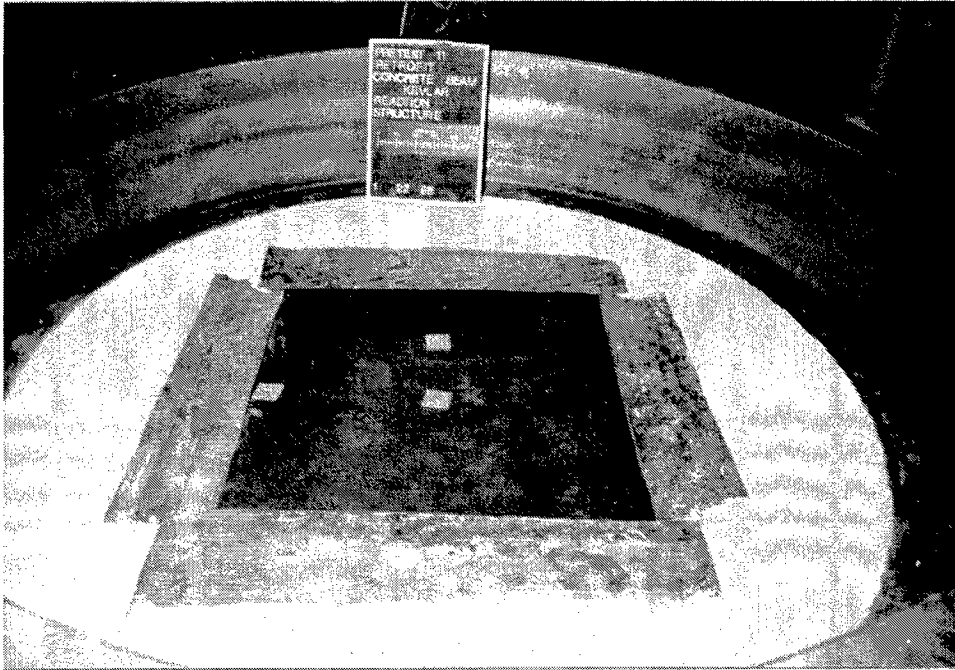

Figure 2.13. The sand is in place with strips of neoprene

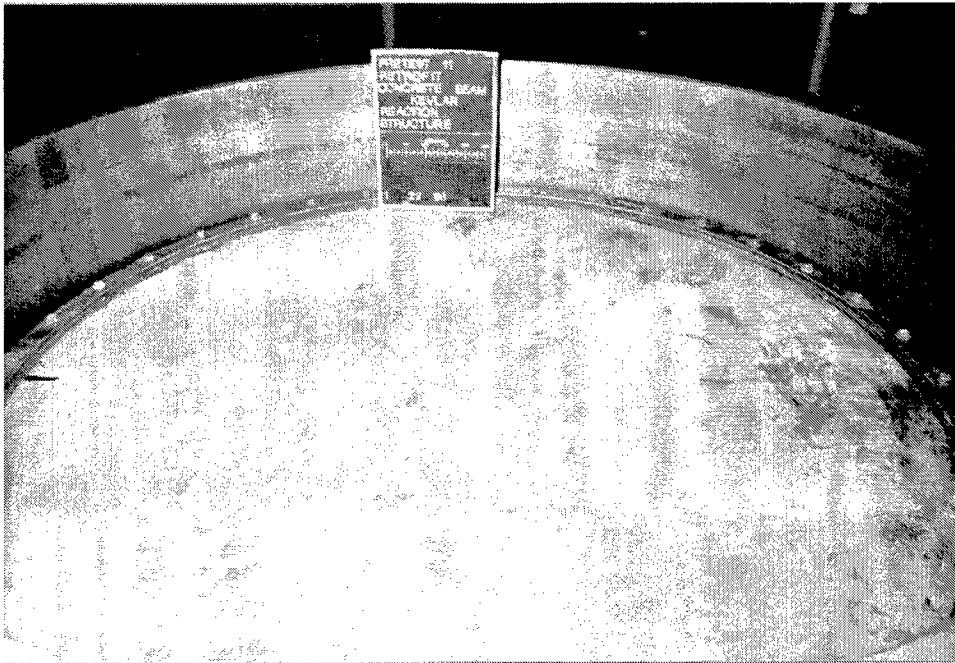

Figure 2.14. Typical test setup with the O-ring in place

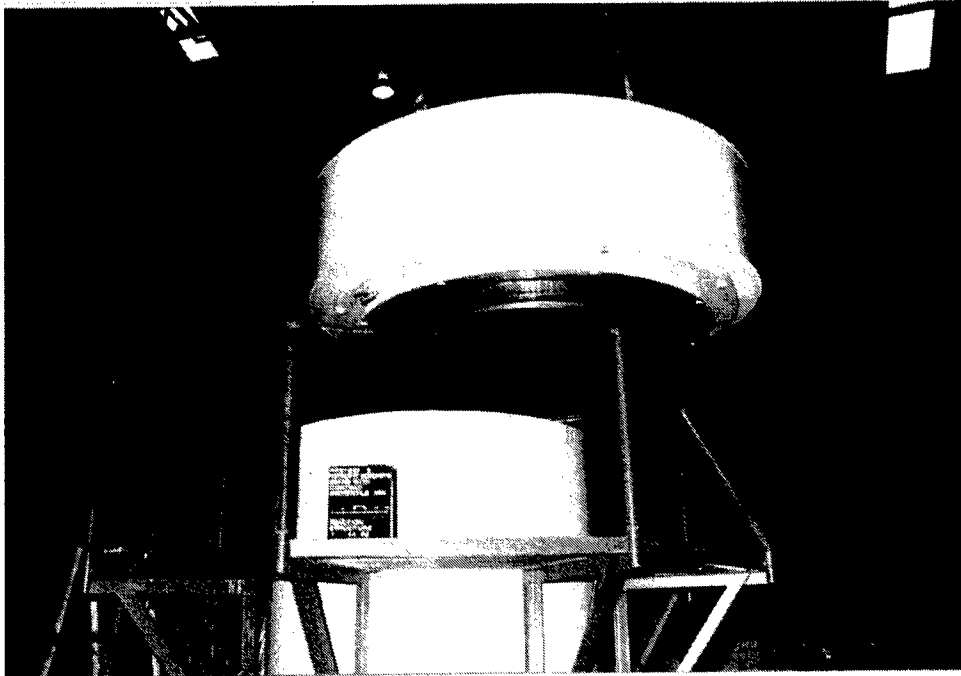

Figure 2.15. The top was placed over the test chamber

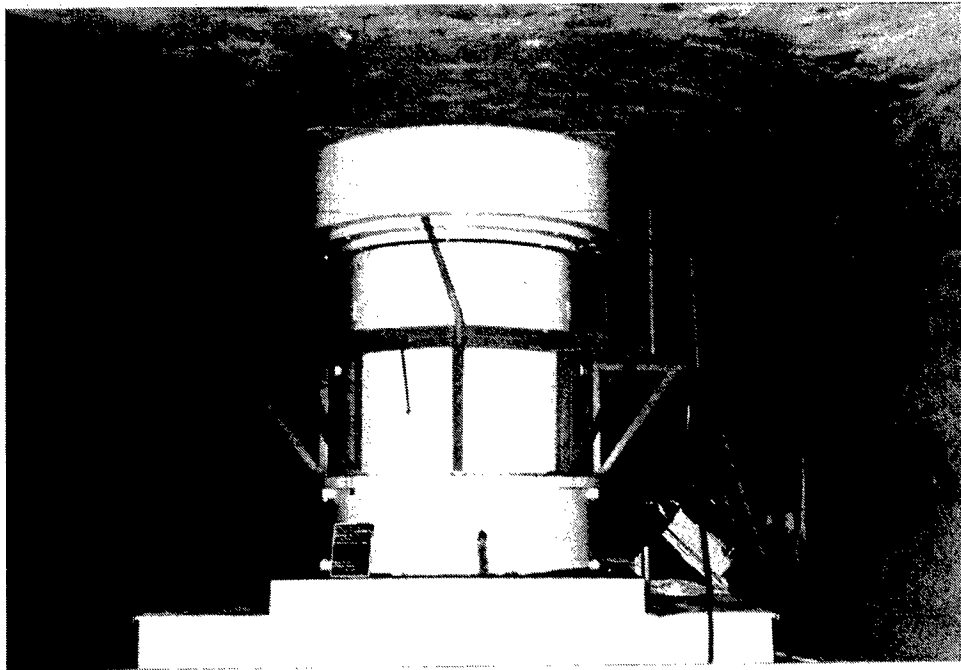

Figure 2.16. The test chamber was cabled into position

3 Test Results

Discussion of the test results will be presented in this chapter. Figures 3.1 through 3.28 are photographs of the pre-test and post-test photographs of each experiment. Table 3-1 presents the predicted and experimental peak pressure, maximum deflection, and failure mode.

Table 3.2 summarizes the deflection profile at peak pressure. Appendix B contains the pressure and deflection gage records for each test. The midspan deflection gage for each test was labeled D3. The plots show pressure versus time, and pressure versus midspan deflection. Some measured peak pressure values compared favorably with the predictions.

Table 3.3 presents the test results in terms of the failure mode. Appendix C contains the ASTM D 4595 test methods that were used to evaluate the material properties.

**Table 3.1
General Test Results of Geogrid/Geotextile Connection Systems**

Material Category	Test No.	Specimen Label	Predicted Peak Pressure (psi)	Experimental Peak Pressure		Maximum Deflection (in.)	Failure Modes
				MD	CD		
Group A	1	GT 600-A	20		11.3	7.2	1
Group A	2	GT 800-A	26		18.0	7.7	1
Group A	3	GT 1715-A	56		11.4	9.2	1
Group A	6	GT 600-B	20	19.6	-	5.2	1
Group A	7	GT 1715-B	56	33.0	-	3.8	1 & 3
Group A	8	Com GT 350-A	65	30.9	-	4.0	2
Group A	9	Com GT 350-B	65	24.8	-	3.6	1
Group A	11	K 1084	35	44.0	-	4.7	1 & 3
Group A	12	GT 800-B	26	32.8	-	4.8	1 & 3
Group A	13	Com GT 350-C	65	30.4	-	4.5	1
Group A	14	Com GT 500	95	37.6	-	4.4	1 & 3
Group B	4	GG 10	22	28.0	-	5.8	1
Group B	5	GG 24	69	21.6	-	6.8	1 & 3
Group B	10	GG 1500	19	14.4	-	7.0	1

Note:

1 - Tear at support.

2 - Fabric slip out of support.

3 - Anchor pullout.

MD - Test in machine direction.

CD - Test in cross-machine direction.

**Table 3.2
Deflection Profile at Peak Pressure**

Material Category	Test No.	Specimen Label	Quarter Span D1 Deflection (in.)	Edge Span D2 Def. (in.)	Mid- Span D3 Def. (in.)	Edge Span D4 Def. (in.)	Experimental Peak Pressure	
							MD	CD
Group A	1	GT 600-A	4.6	3.4	6.7	7.2	-	11.3
Group A	2	GT 800-A	4.4	7.7	6.2	2.6	-	18.0
Group A	3	GT 1715-A	7.0	2.3	6.8	9.2	-	11.4
Group A	6	GT 600-B	3.2	2.5	5.2	N/A	19.6	-
Group A	7	GT 1715-B	3.0	3.3	3.8	2.9	33.0	-
Group A	8	Com GT 350-A	3.1	4.0	N/A	2.6	30.9	-
Group A	9	Com GT 350-B	N/A	3.6	3.4	2.5	24.8	-
Group A	11	K 1084	3.7	N/A	4.6	4.7	44.0	-
Group A	12	GT 800-B	2.2	3.4	4.8	4.1	32.8	-
Group A	13	Com GT 350-C	1.8	2.5	4.5	2.8	30.4	-
Group A	14	Com GT 500	3.3	3.8	4.4	4.0	37.6	-
Group B	4	GG 10	5.8	N/A	4.2	3.4	28.0	-
Group B	5	GG 24	6.2	5.6	6.8	2.9	21.6	-
Group B	10	GG 1500	N/A	3.3	7.0	2.4	14.4	-

MD - Test in machine direction.
CD - Test in cross-machine direction.

**Table 3.3
Test Results in Terms of Failure Modes**

Failure Modes	Material Category	Test No.	Specimen Label	Experimental Peak Pressure	
				MD	CD
1	Group A	1	GT 600-A	-	11.3
1	Group A	2	GT 800-A	-	18.0
1	Group A	3	GT 1715-A	-	11.4
1	Group B	4	GG 10	28.0	
1	Group A	6	GT 600-B	19.6	
1	Group A	9	Com GT 350-B	24.8	
1	Group B	10	GG 1500	14.4	
1	Group A	13	Com GT 350-C	30.4	
2	Group A	8	Com GT 350-A	30.9	
1 & 3	Group B	5	GG 24	21.6	
1 & 3	Group A	7	GT 1715-B	33.0	
1 & 3	Group A	11	K 1084	44.0	
1 & 3	Group A	12	GT 800-B	32.8	
1 & 3	Group A	14	Com GT 500	37.6	

Note:
1 - Tear at support.
2 - Fabric slip out of support.
3 - Anchor pullout.
MD - Test in machine direction.
CD - Test in cross-machine direction.

Group A, Test 1

The 600 geotextile was tested in the cross machine direction. This geotextile tore loose at the support on one side of the connection system. No damage was sustained to the anchors or the beams. The geotextile failed at a peak pressure of approximately 11.3 psi and had a maximum deflection of 7.2 inches. The

predicted pressure (presented in Table 3.1) was not reached because the material was tested in the cross machine direction.

Group A, Test 2

The 800 Geotextile was tested in the cross machine direction. This geotextile tore loose at the support on one side of the beam. No damage was sustained to the anchors or the beams. This geotextile failed at a peak pressure of approximately 18.0 psi and had a maximum deflection of approximately 7.7 inches. The predicted pressure of this fabric was not reached because the material was tested in the cross machine direction.

Group A, Test 3

The 1715 geotextile was tested in the cross machine direction. This geotextile tore loose at the supports on both sides of the beams. No damage was sustained to the anchors or to the beams. The peak pressure of this geotextile was approximately 11.4 psi and had a maximum deflection of approximately 9.2 inches. The peak pressure for this test was much lower than the prediction due to a weaker strength of the material in the cross machine direction.

Group A, Test 6

The 600 geotextile was tested in the machine direction. The geotextile tore loose over a length of 26-in along one side of the beam. There was no visible damage to the beams or anchors. The peak pressure of this fabric was approximately 19.6 psi, and it had a maximum deflection of approximately 5.2 inches. The fabric reached the prediction pressure due to the testing of the material in the machine direction.

Group A, Test 7

The 350 Com Geotextile was tested in the machine direction. The geotextile tore loose over a length of 20-in. along one side of the beam. No damage was sustained to the beams; however, there was a maximum anchor pullout of approximately 0.25- inch. The peak pressure of this fabric was approximately 33.0 psi and had a maximum deflection of approximately 3.8 inches. The peak pressure from this test was lower than the prediction.

Group A, Test 8

The 350 Com Geotextile was tested in the machine direction. The geotextile slipped out of the plate. This slippage occurred because one of the anchors could not be tightened. This geotextile failed at a peak pressure of approximately

30.9 psi, and it had a maximum deflection of approximately 4.0 inches. This fabric did not reach the predicted peak pressure.

Group A, Test 9

The 350 Com Geotextile was tested in the machine direction. The geotextile tore loose at a 20-in. span along one side of the beam. There was no damage sustained to the beams or anchors. The peak pressure of this geotextile was approximately 24.8 psi and had a maximum deflection of approximately 3.6 inches. This geotextile failed prematurely based on the designed tensile strength of the fabric.

Group A, Test 11

The Kevlar material was tested in the cross machine direction. The Kevlar tore loose at a 26-in. span along one side of the beam. There was no damage sustained to the beams; however, the anchors and the steel plate had a maximum pullout of approximately 1 inch. There were five anchors that pulled out on the side of the beam where the failure occurred. The peak pressure of this material was approximately 44.0 psi, occurring at a maximum deflection of approximately 4.7 inches. This material did reach the predicted pressure.

Group A, Test 12

The 800 Geotextile was tested in the machine direction. The geotextile tore loose over a length of 21-in. along one side of the beam. There was no damage to the beams; however, the steel plate and the anchors experienced a maximum pullout of approximately 0.75 inch. There were seven anchors that pulled out on the side of the beam where the failure occurred. The peak pressure of the fabric was approximately 32.8 psi, with a maximum deflection of approximately 4.8 inches. The pressure from this test exceeded the predicted pressure.

Group A, Test 13

The 350 Com Geotextile was tested in the machine direction. The geotextile tore loose over a length of 2-in. along one side of the beam. There was no damage to the beams or the anchors. The peak pressure of the fabric was approximately 30.4 psi, a maximum deflection was approximately 4.5 inches. This fabric did not sustain much damage; however, it did not reach the predicted pressure.

Group A, Test 14

The 500 Com Geotextile was tested in the machine direction. The geotextile tore loose on both sides of the beams over a length of 23-in. on one side of the beam. There was damage sustained to the beams; however, the anchors had a maximum pullout of approximately 0.125-inch. The fabric failed at a peak pressure of approximately 37.6 psi, with a maximum deflection of approximately 4.4 inches. This fabric did not reach the predicted pressure.

Group B, Test 4

The 10XT Geogrid was tested in the machine direction. The geogrid tore loose over a length of 18-in. along one side of the beam. The grids on the other side stayed attached. There was no damage to the beams or anchors. The geogrid started failing at a peak pressure of approximately 28.0 psi and had a maximum deflection of approximately 5.8 inches. The geogrid used in this test exceeded the predicted pressure.

Group B, Test 5

The 24XT Geogrid was tested in the machine direction. The geogrid tore loose over a length of 20-in. along one side of the beam. The steel plate that anchored the geogrid started to bend. There was some minor anchor pullout. No damage was sustained to the beams. The peak pressure of this geogrid was approximately 21.6 psi, and it had a maximum deflection of approximately 6.8 inches. The peak pressure of this 24XT was lower than that of the 10XT; however, the tensile strength of 24XT was about three times the strength of the 10XT geogrid. The premature failure was due to a weaker strength in the cross machine direction.

Group B, Test 10

The UX 1500 Geogrid was tested in the cross machine direction. The geogrid tore loose over a length of 24-in. along one side of the beam and also tore loose at the center. There was no visible damage to the beams or anchors. The geogrid failed at a peak pressure of approximately 14.4 psi, with a maximum deflection of approximately 7.0 inches. This material did reach the predicted pressure.

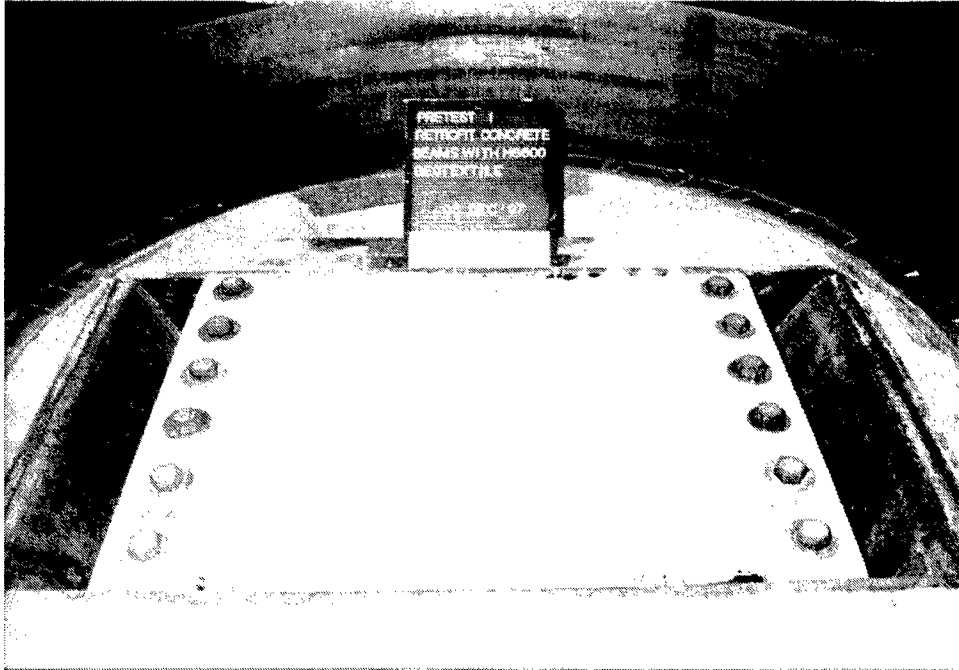

Figure 3.1. Group A test 1 pretest

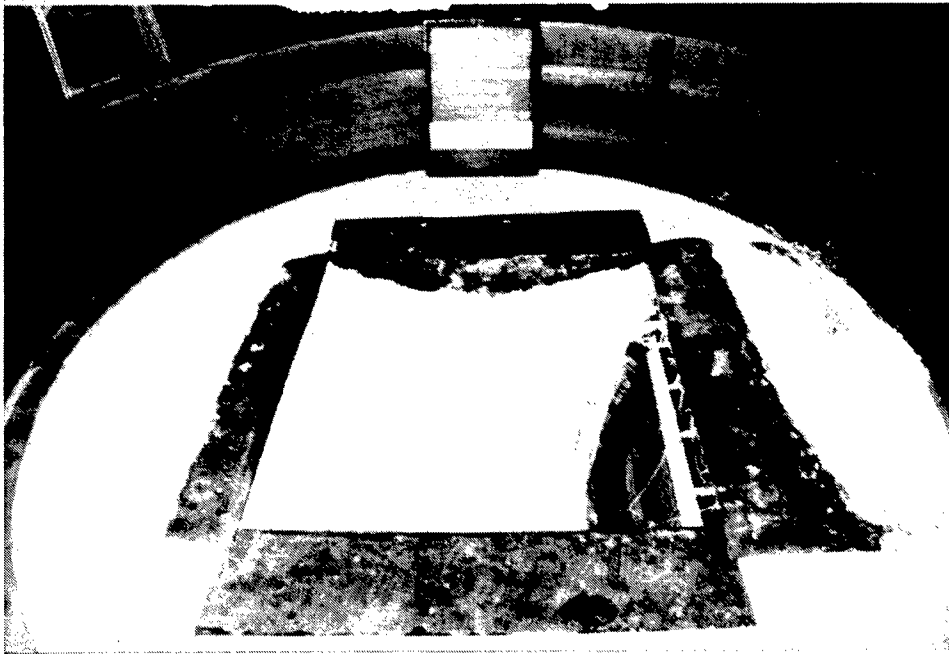

Figure 3.2 . Group A test 1 posttest

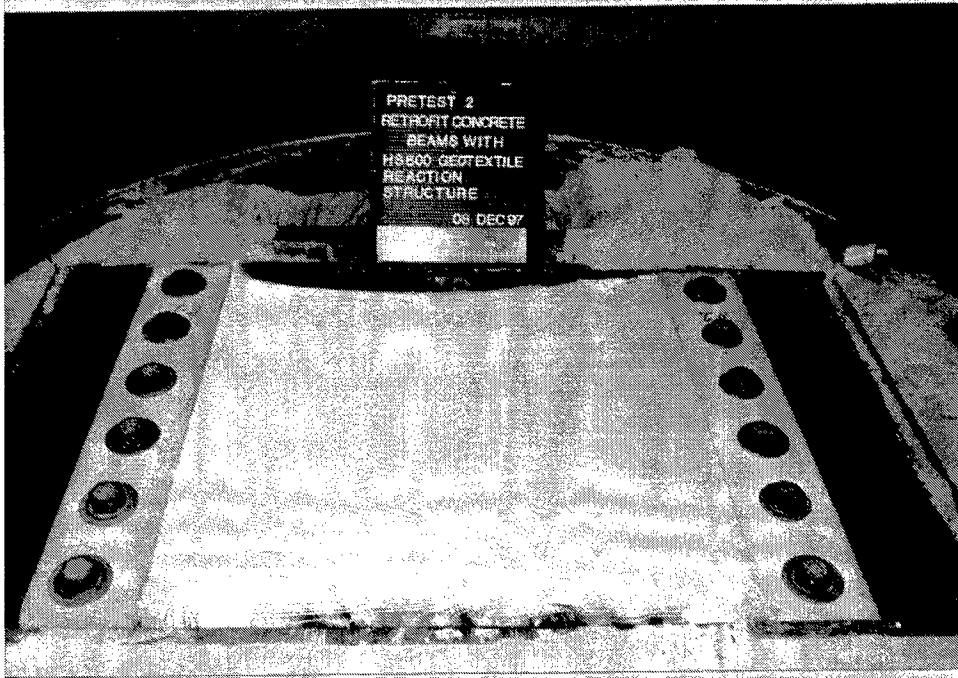

Figure 3.3. Group A test 2 pretest



Figure 3.4. Group A test 2 posttest

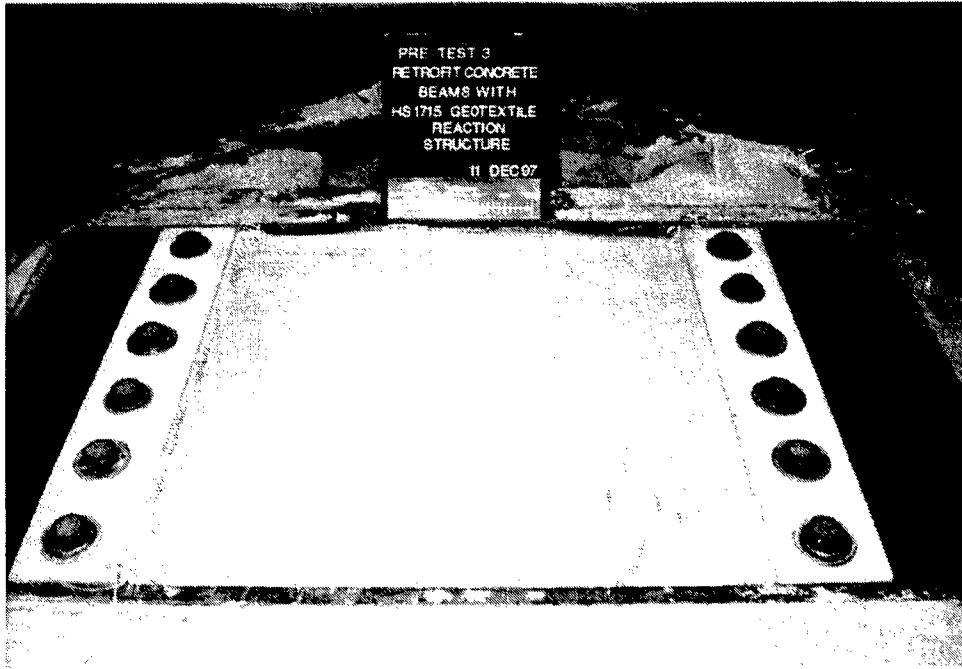

Figure 3.5. Group A test 3 pretest

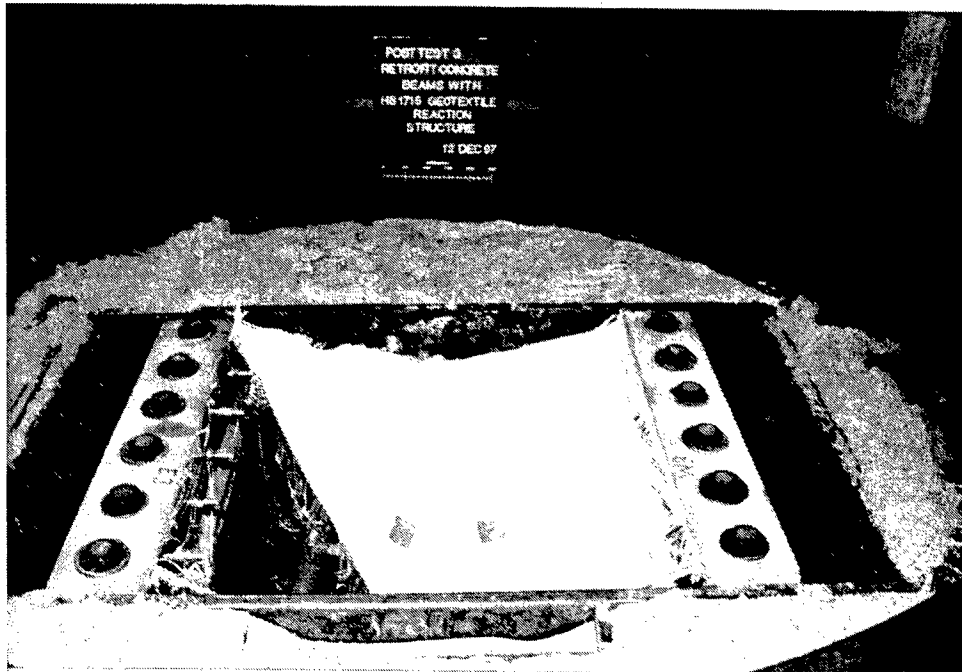

Figure 3.6. Group A test 3 posttest

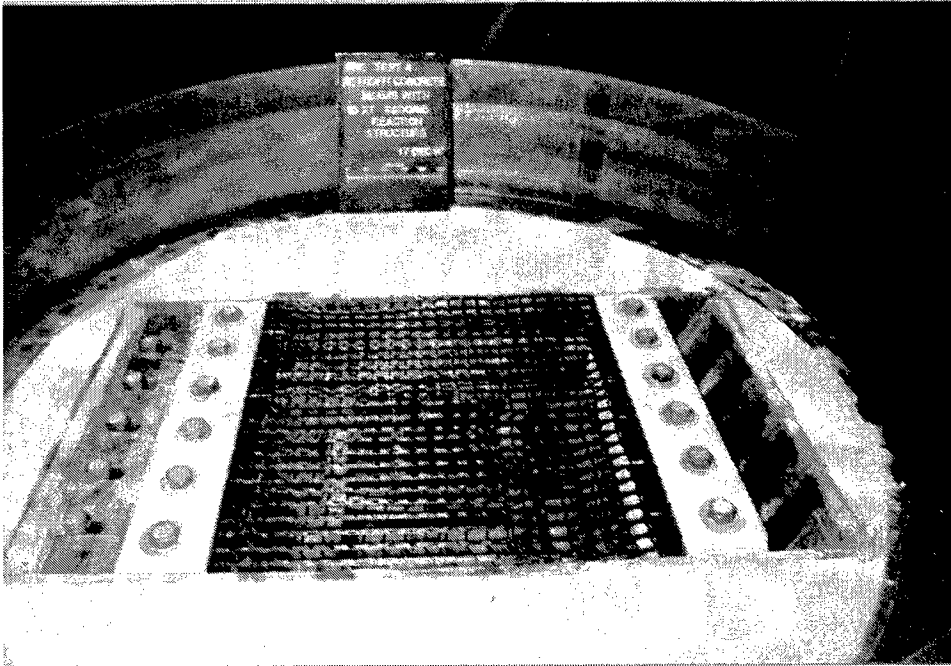

Figure 3.7. Group B test 4 pretest

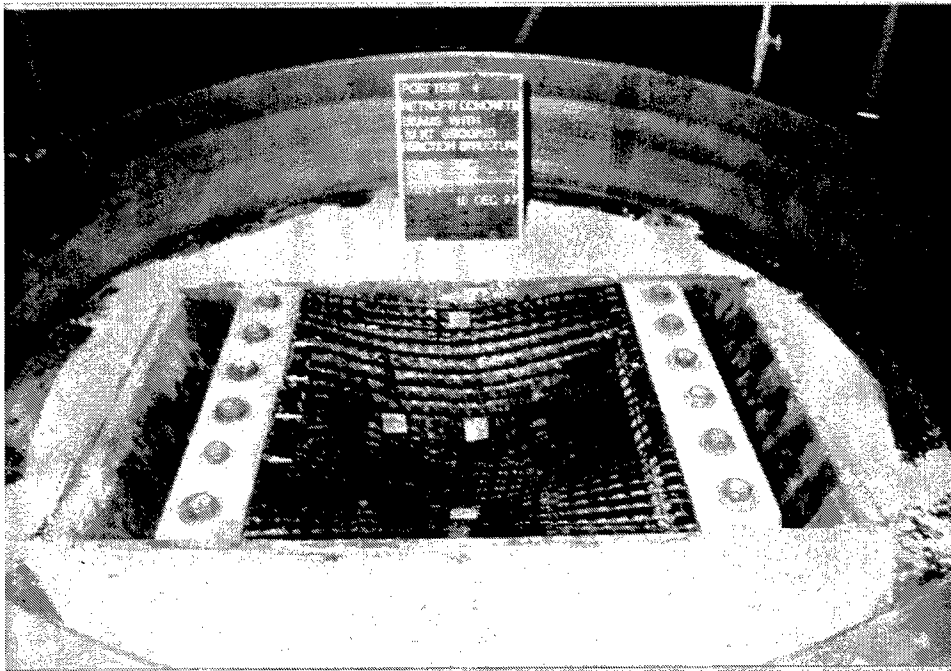

Figure 3.8. Group B test 4 posttest

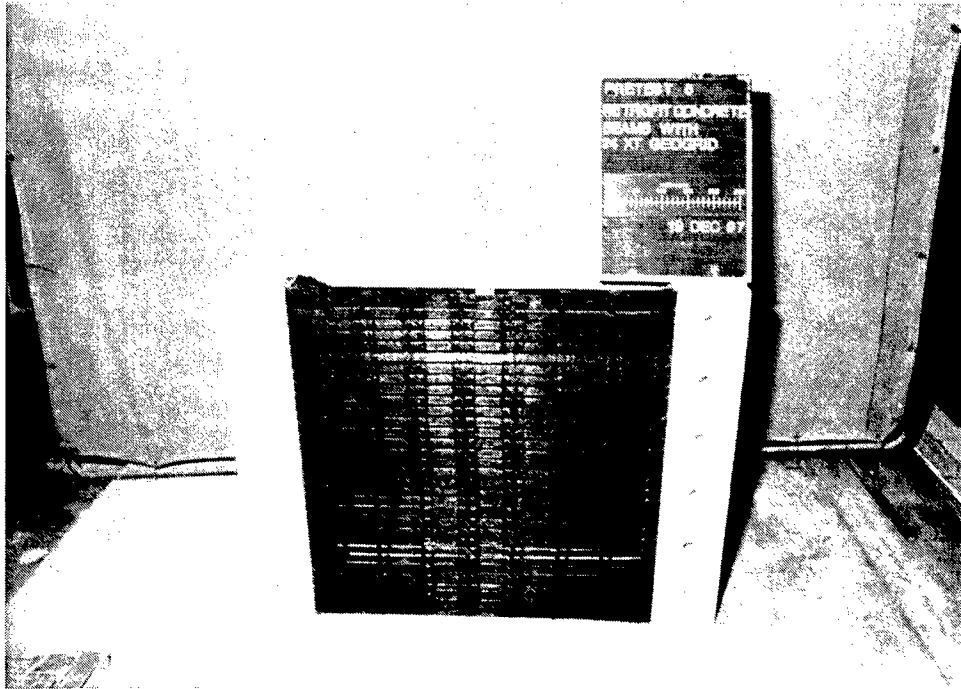

Figure 3.9. Group B test 5 pretest

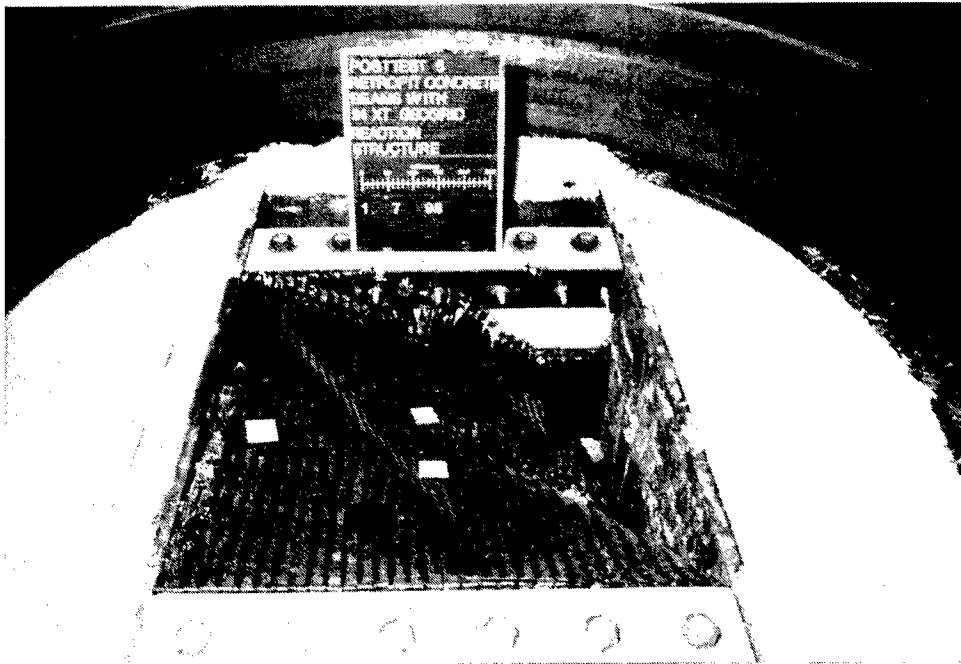

Figure 3.10. Group B test 5 posttest

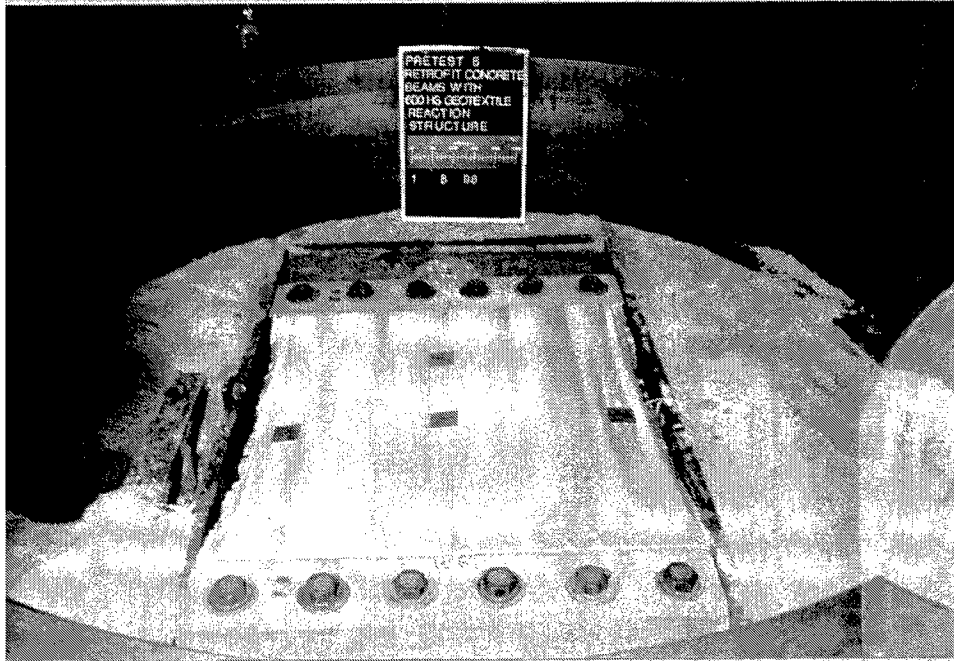

Figure 3.11. Group A test 6 pretest

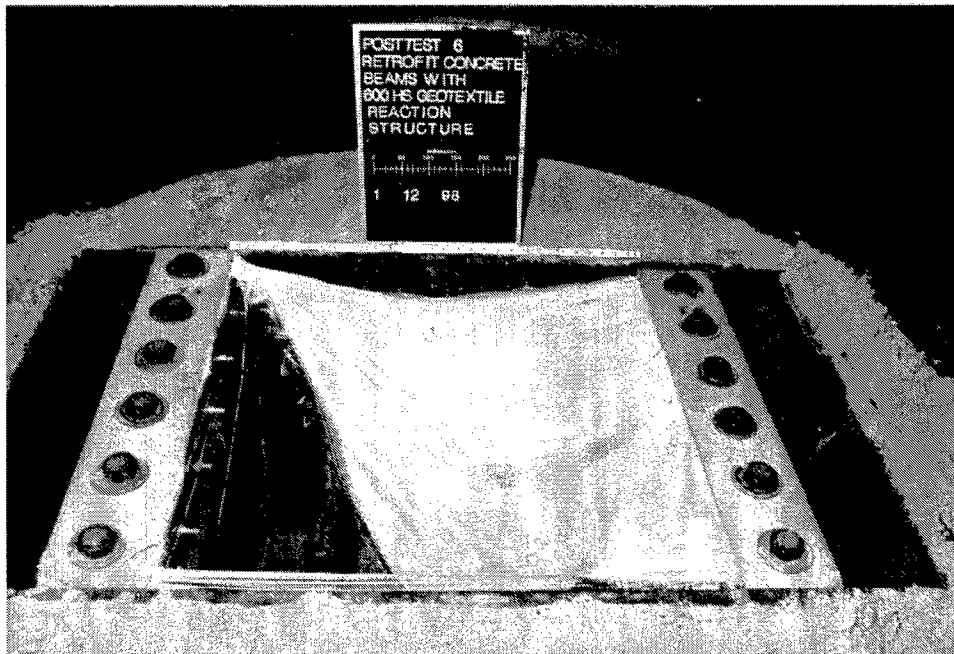

Figure 3.12. Group A test 6 posttest

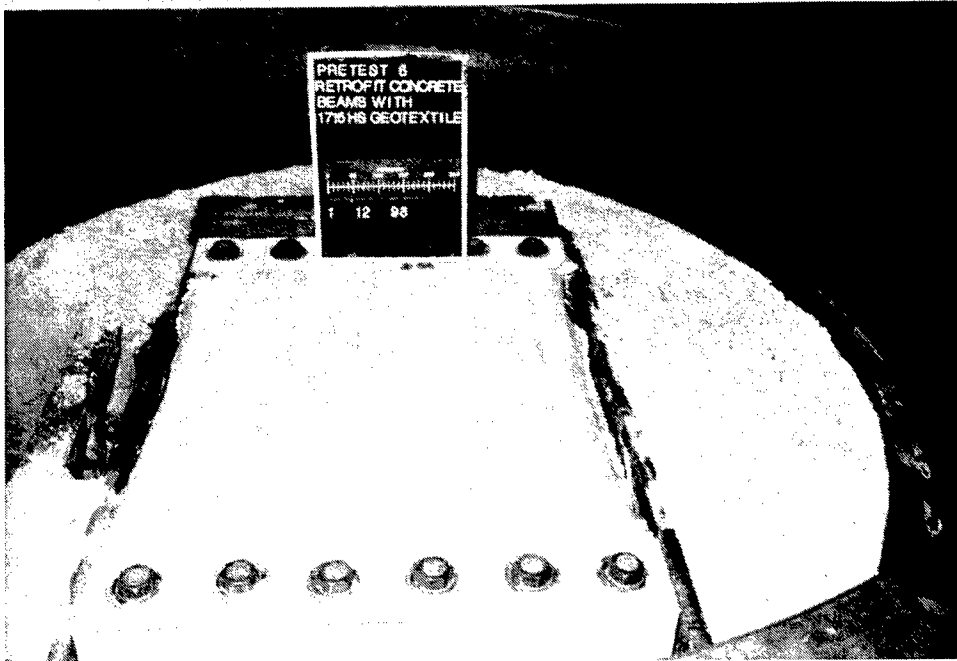

Figure 3.13. Group A test 7 pretest

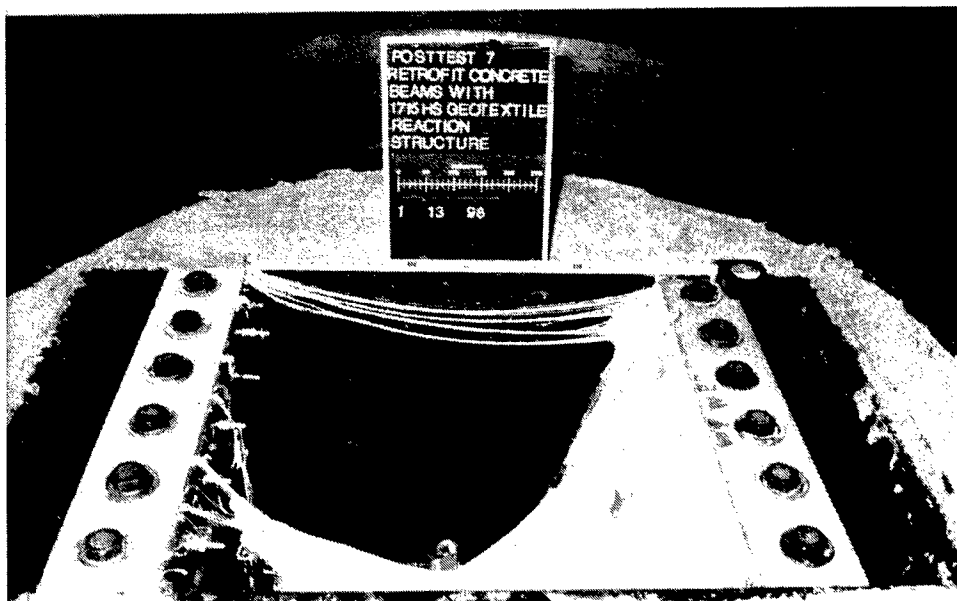

Figure 3.14. Group A test 7 posttest

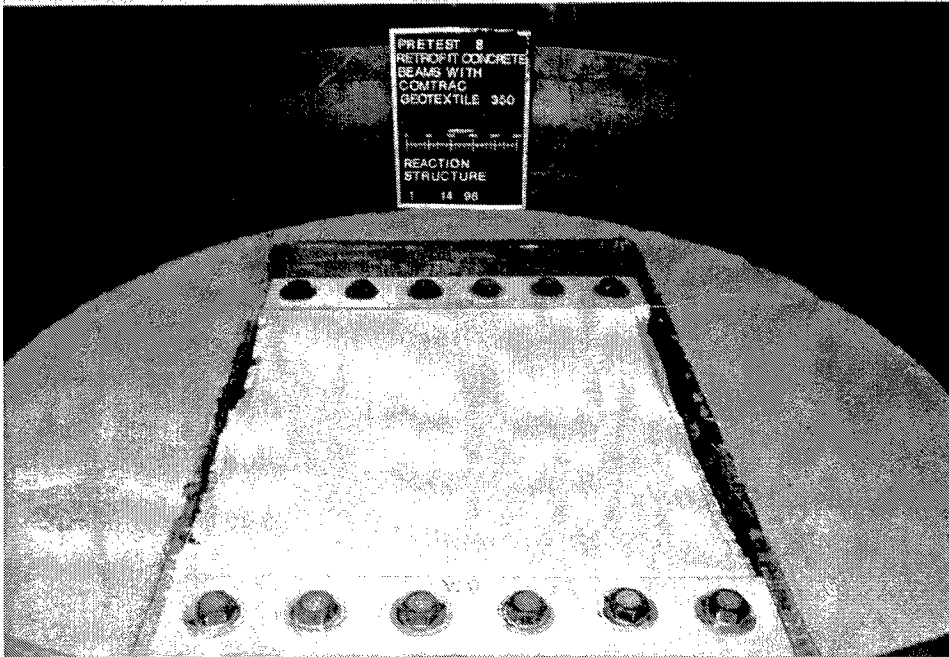

Figure 3.15. Group A test 8 pretest

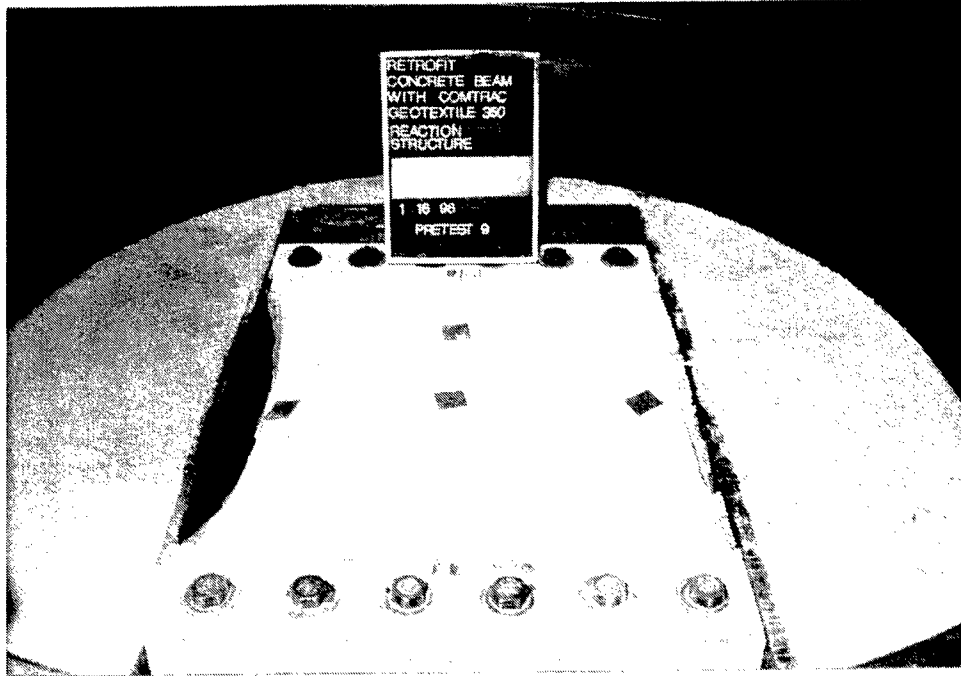

Figure 3.16. Group A test 9 pretest

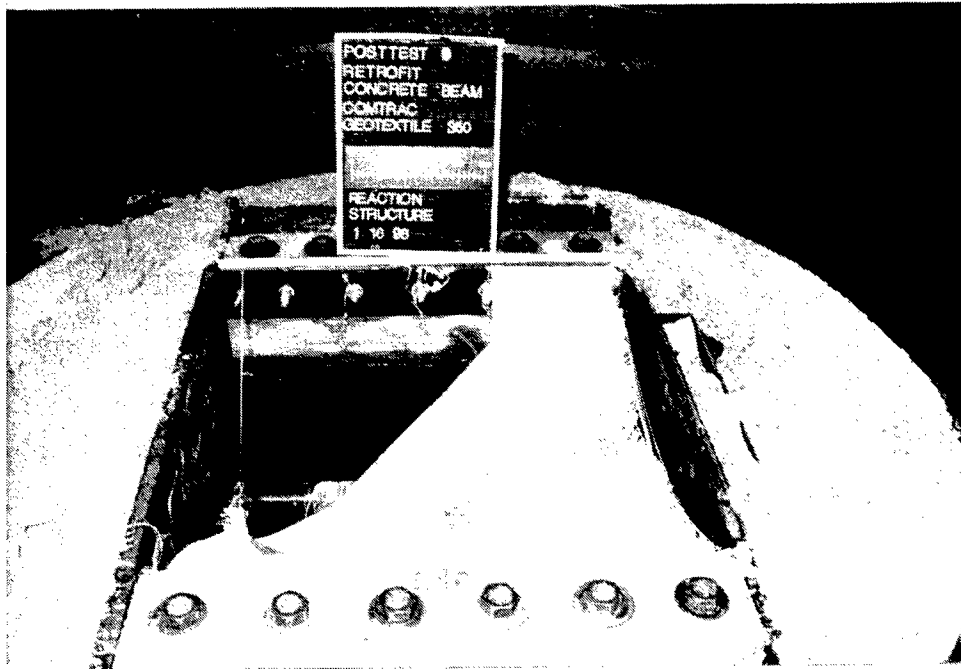

Figure 3.17. Group A test 9 posttest

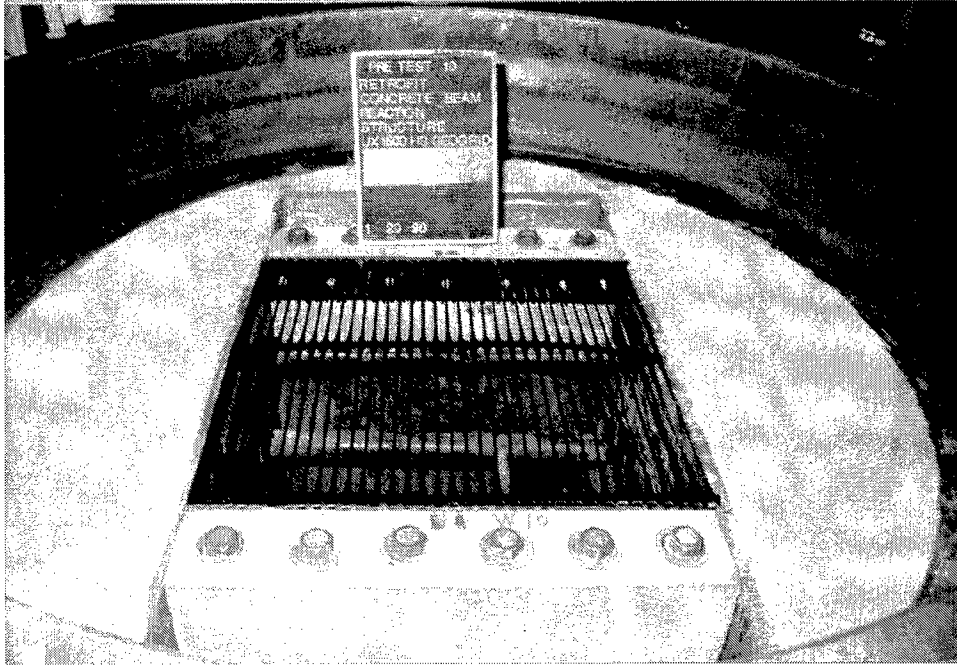

Figure 3.18. Group B test 10 pretest

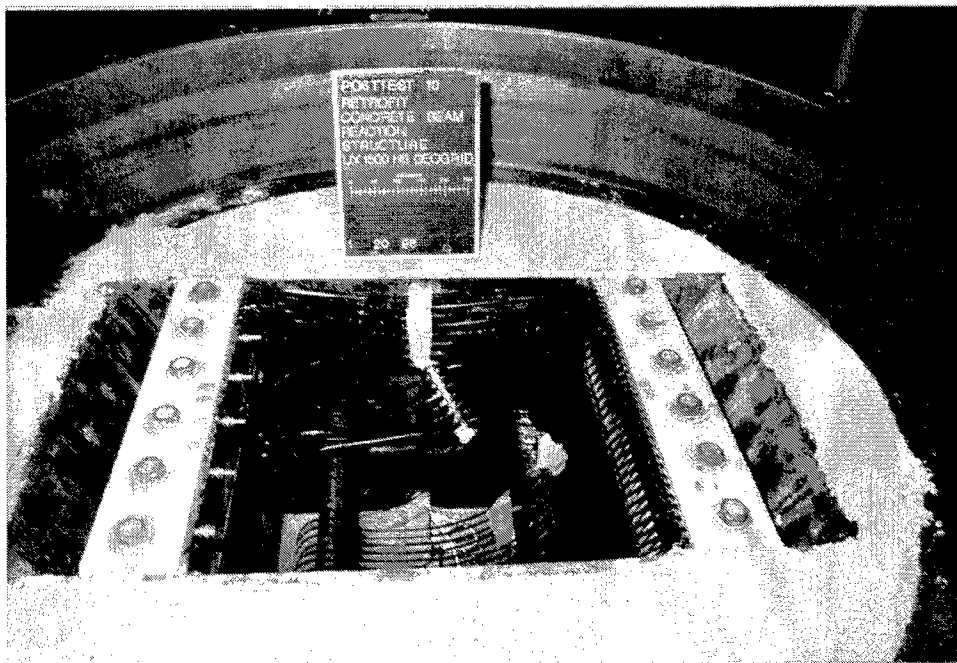

Figure 3.19. Group B test 10 posttest

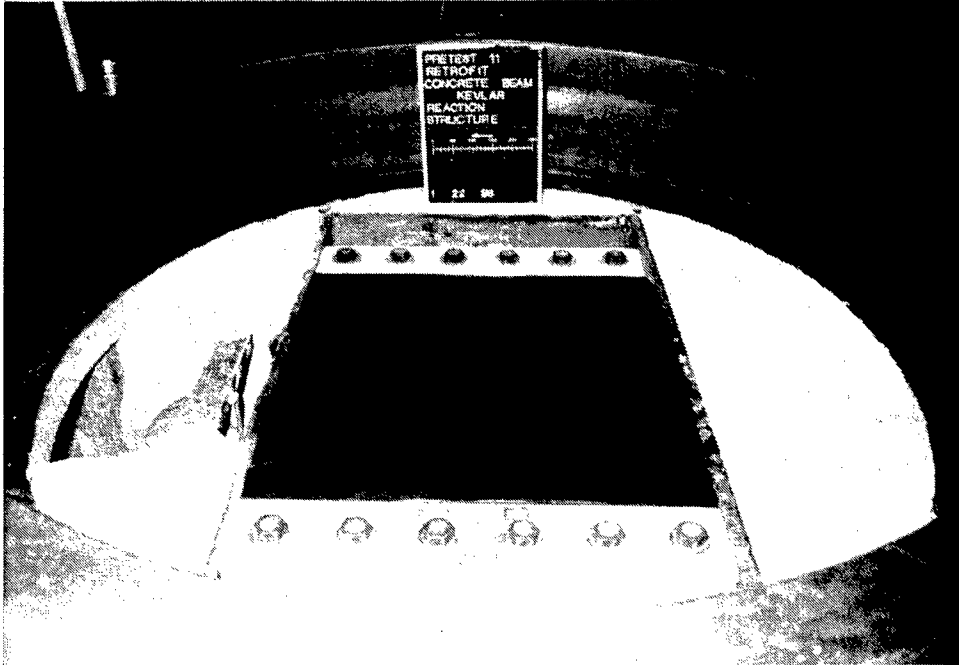

Figure 3.20. Group A test 11 pretest

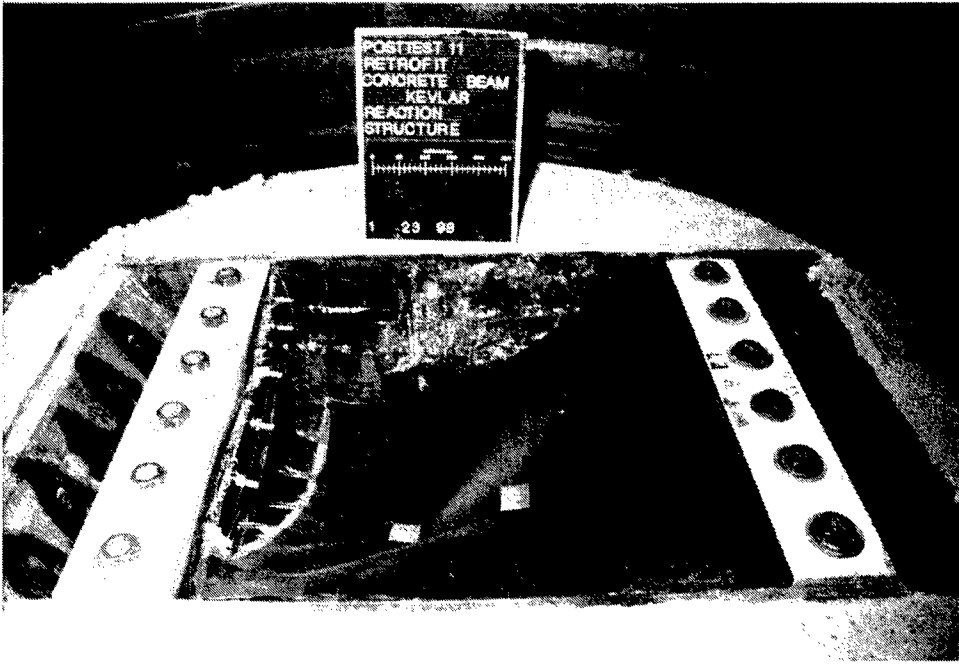

Figure 3.21. Group A test 11 posttest

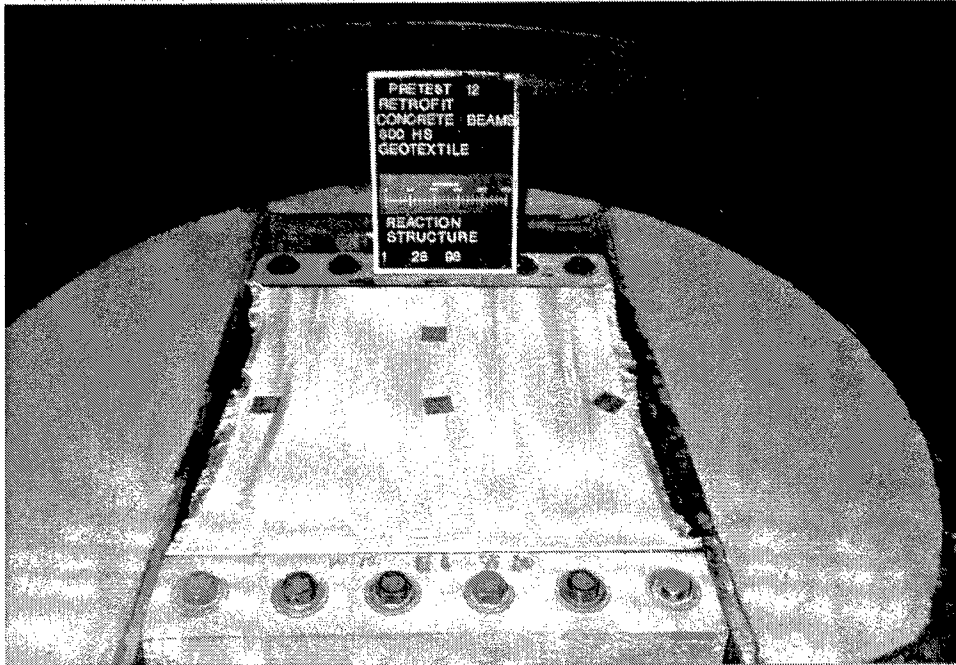

Figure 3.22. Group A test 12 pretest

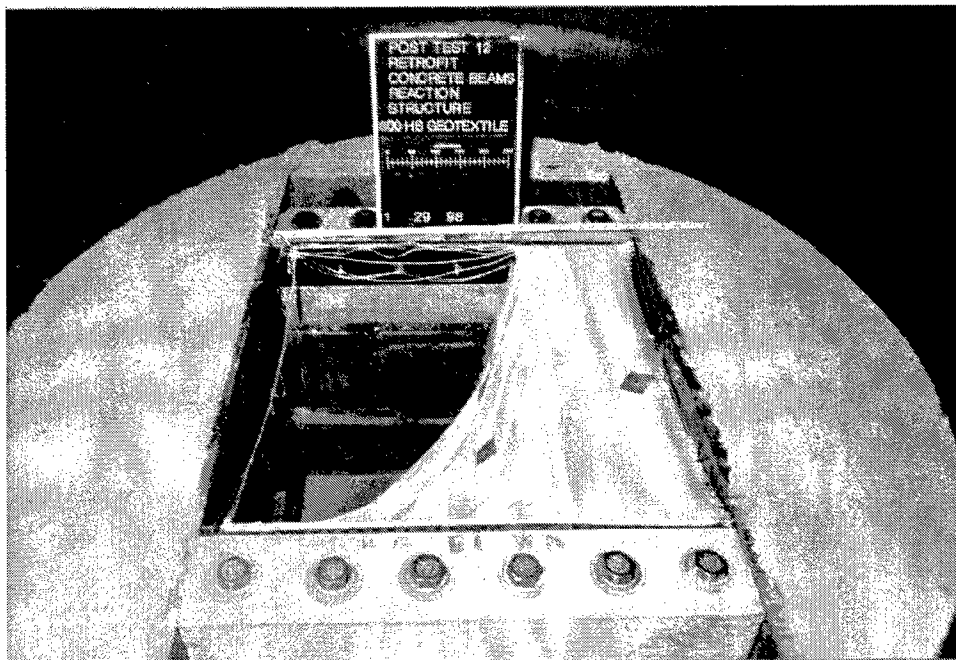

Figure 3.23. Group A test 12 posttest

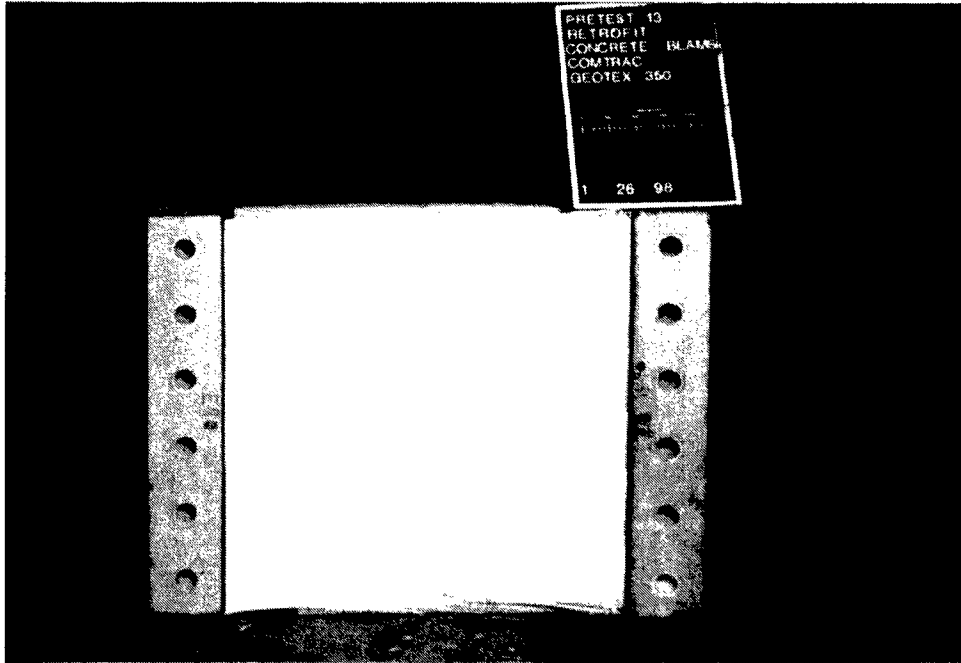

Figure 3.24. Group A test 13 pretest

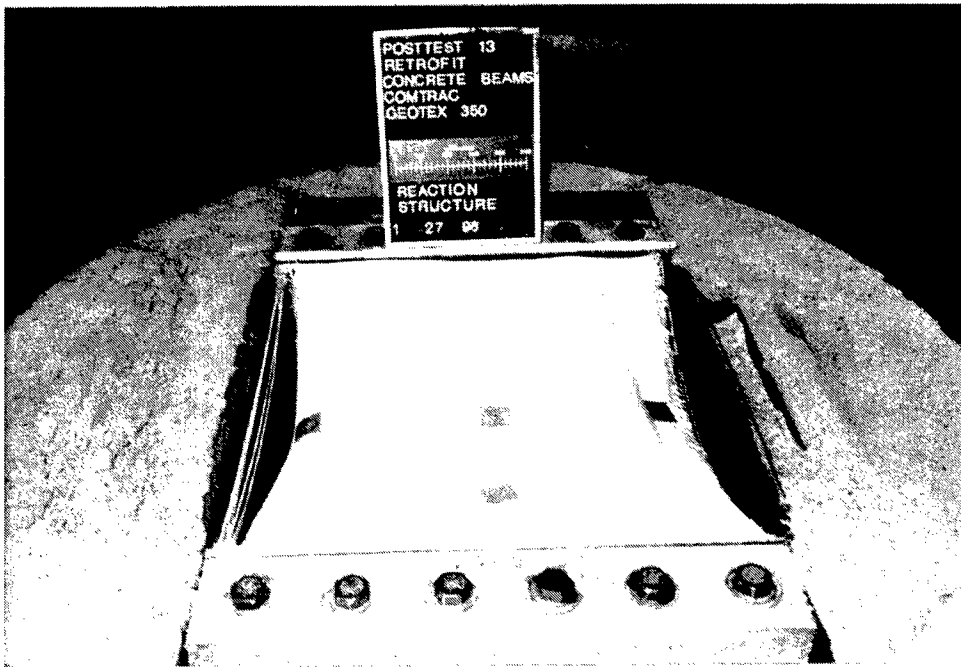

Figure 3.25. Group A test 13 posttest

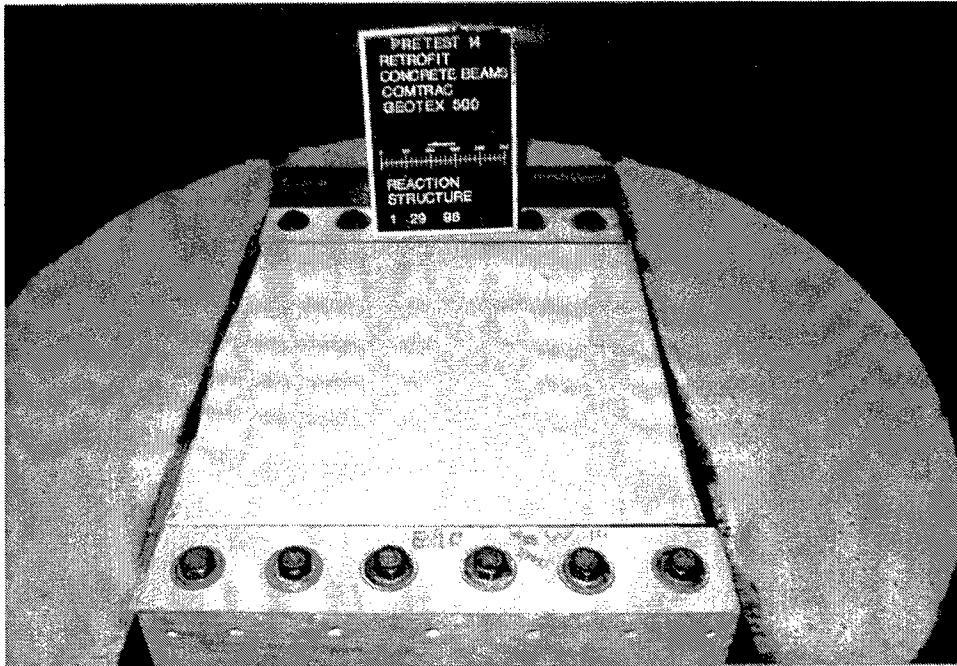

Figure 3.26. Group A test 14 pretest

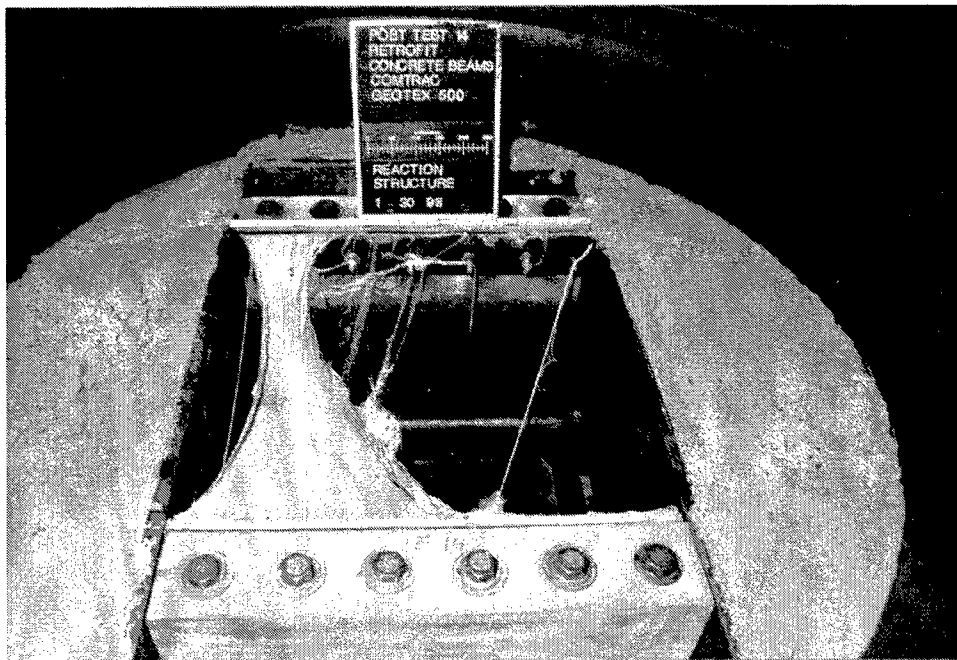

Figure 3.27. Group A test 14 posttest

4 Analyses and Discussion of Experimental Results

Analyses and discussion of the experimental results will be presented in this chapter. This chapter will consider the failure modes described in the previous chapter and compare the results of the ASTM tests with the experimental results.

Failure Modes

The failure modes were presented in Chapter III. Table 3.1 summarizes the test results with the failure mode definitions. Table 4.1 presents the experimental results versus the ASTM 4595 test results and the fabrics' ultimate strengths.

Failure Modes	Material Category	Test No.	Specimen Label	Fabric's Ultimate Strength (lb/in.)	Experimental Strength (lb/in.)		ASTM 4595 Test Results (lb/in.)
					MD	CD	
1	Group A	1	GT 600-A	600	-	345	399
1	Group A	2	GT 800-A	800	-	549	518
1	Group A	3	GT 1715-A	1715	-	348	557
1	Group A	6	GT 600-B	600	598	-	561
1	Group A	9	Com GT 350-B	1995	756	-	1266
1	Group A	13	Com GT 350-C	1995	927	-	1266
1	Group B	4	GG 10	658	854	-	415
1	Group B	10	GG 1500	575	439	-	482
2	Group A	8	Com GT 350-A	1995	942	-	1266
1 & 3	Group A	7	GT 1715-B	1715	1007	-	995
1 & 3	Group A	11	K 1084	1084	1342	-	675
1 & 3	Group A	12	GT 800-B	800	1000	-	760
1 & 3	Group A	14	Com GT 500	2885	1147	-	1467
1 & 3	Group B	5	GG 24	2115	659	-	617

Failure Mode 1, Group A

Tests 1, 2, and 3

The specimens in Tests 1, 2, and 3 were tested in the cross machine direction. The failure mode from Test 1 was a result of the fabric tearing at the supports.

In Chapter III, it was mentioned that the 600 fabric did not reach the prediction; however, the fabric did reach the prediction for the cross machine direction. The failure modes observed in Tests 2 and 3 were also a result of the 800 and 1,715 fabrics tearing at the supports. The predictions for these tests were also reached when the cross machine direction was used.

Tests 6, 9, and 13

The failure mode of the 600 Geotextile from Test 6 was the result of the fabric tearing at the supports. There was no pullout of the anchors or damage to the beams. The prediction of this fabric was reached in the machine direction. The failure mode of the 350 Com GT in Test 9 was a result of the fabric tearing at the supports. The prediction for Test 9 was not reached. The failure mode of the 350 Com GT from Test 13 was the result of the fabric tearing at the supports. The predicted pressure of this fabric was also not reached.

Failure Mode 1, Group B

Tests 4 and 10

The failure mode of the 10XT Grid from Test 4 was a result of the grid tearing at the supports. There was no pullout of the anchors or damage to the beams. This geogrid exceeded the predicted pressure. The failure mode of the 1500 Geogrid in Test 10 was the result of the grid tearing at the supports. This geogrid was close to reaching the predicted pressure.

Failure Mode 2, Group A

Test 8

The failure mode of the 350 Com Geotextile from Test 8 was the result of the geotextile slipping out of the plate. The predicted pressure was not reached for this fabric.

Failure Modes 1 and 3, Group A

Tests 7, 11, 12, and 14

The failure mode of the 1715 Geotextile from Test 7 was the result of the fabric tearing at the supports and some pullout of the anchors. This fabric did not reach the tensile strength in the machine direction. The failure mode of the Kevlar material from Test 11 was a result of tearing at the supports and some pullout of the anchors. The material exceeded the predicted pressure. The failure

mode of the 800 Geotextile in Test 12 was a result of the fabric tearing at the supports and some anchor pullout. The tensile strength of this fabric was reached because it was tested in the machine direction. The failure mode of the 500 Com CT from Test 14 was a result of tearing at the supports and some anchor pullout. The prediction for this test was not reached.

Failure Modes 1 and 3, Group B

Test 5

This geogrid exceeded the predicted pressure. The failure mode of the 24XT Grid from Test 5 was the result of tearing at the supports and some pullout of the anchors. The prediction in this test was not reached.

ASTM Tests Versus Experimental Results

This section will compare the ASTM 4595 material properties test results with the static test results. Some discussion of the vendor tensile strength of the materials will be included. Table 4.1 presented the different strengths of the fabrics.

Group A

600 GT

The ASTM test result of the 600 GT was close to the static test tensile strength, with a tensile strength of approximately 561 lb/inch. The fabric was tested in the machine direction. The ASTM test of the 600 GT in the cross machine had a tensile strength, approximately 399 lb/in., higher than the static test.

800 GT

The ASTM test result of the 800 GT in the machine direction was close to the static test results, with a tensile strength of approximately 760 lb/in. The ASTM test result of this fabric in the cross machine direction was close to the strength of the static test with a tensile strength of approximately 518 lb/in.

1715 GT

The ASTM test result of the 1715 GT in the machine direction was close to the static test results, with a tensile strength of approximately 995 lb/in. The

ASTM test result of this fabric in the cross machine direction had a higher strength approximately 557 lb/in., than the static test result.

350 Com GT

The ASTM test result of the 350 Com GT in the machine direction had a tensile strength, approximately 1,266 lb/in., higher than the tensile strength force induced during the static test. The results from the ASTM test and the static test were both lower than the vendor-ultimate tensile strength.

500 Com GT

The ASTM test result of the 500 Com GT in the machine direction had a tensile strength, approximately 1,467 lb/in., higher than the tensile strength force induced during the static test. The results from the ASTM test and the static test were both lower than the vendor-ultimate tensile strength.

Kevlar

The ASTM test result of the Kevlar material in the machine direction had a tensile strength, approximately 675 lb/in., lower than the tensile strength force induced during the static test. The result from the static test was higher than the vendor-ultimate tensile strength.

Group B

10 XT GG

The ASTM test result of the 10XT GG in the machine direction had a tensile strength approximately 415 lb/in., lower than the tensile strength force induced during the static test. This result was also lower than the vendor ultimate tensile strength.

24 XT GG

The ASTM test result of the 24XT GG in the machine direction had a tensile strength, approximately 617 lb/in., close to the tensile strength force induced during the static test. The results from the ASTM test and the static test were lower than the vendor-ultimate tensile strength.

1500 GG

The ASTM test result of the 1500 GG material in the cross machine had a tensile strength, approximately 482 lb/in., close to the tensile strength force induced during the static test. The results from the ASTM test and the static test were close to the vendor-ultimate tensile strength.

The ASTM specimen was an 8-in. X 8-in. sample that was tested by pulling the specimen in tension and the experimental results were obtained by testing the fabrics with a slowly increased uniform load (water pressure). The test methods were entirely different. The experiments were an evaluation of the retrofit system and not a direct comparison of the material strength.

5 Summary, Conclusions, and Recommendations

Summary

The objective of the experiments was to evaluate the performance of a retrofit system that consists of geotextile and geogrid materials anchored to reinforced concrete beams. The geotextiles were arranged in Group A, and the geogrids were placed in Group B. The ultimate capacity and large-deflection behavior of these retrofit systems were determined. A critical issue regarding retrofit systems is the development of practical and effective techniques for anchoring the geotextile and geogrid materials to the reinforced concrete beams and slabs of a structure. Thus, the primary purpose of this thesis was to develop a connection design with anchors, geotextile, and geogrid materials to reduce the hazard of wall-debris fragments. Several types of geotextile and geogrid materials were selected, with tensile strength ranging from 600 lb/in. to 3,000 lb/in.

Conclusions

The conclusions from the experiments conducted on the Group A and Group B materials are dependent on the tensile strength of the materials and the anchor system. The results and the conclusions are valid only for the anchor system used in the experiments. The comparison of the geotextiles with the geogrids is not the primary issue in this test series. The test results indicated that the lower strength geotextiles and geogrids both performed well. A designer should use the lower strength geotextile/geogrid over the higher strength materials because there is a better balance of the tensile strengths in cross machine and machine directions. These results may not be true in soils and pavement designs. Test results from Chapter III showed that the direction in which the fabrics were tested affected the resistance of the system. The test results showed that all of the specimens tested, except the Group A GT-350-A, had a failure mode 1, which corresponds to tearing at the supports. The specific conclusions for the test series are listed below in group order.

- a.* Group A GT 600 reached the maximum tensile strength in both directions.
- b.* Group A GT 800 reached the maximum tensile strength in both directions.
- c.* Group A GT 1715 was tested in the machine direction, and maximum tensile strength was not reached with this fabric.
- d.* Group A Com GT 350 was tested in the machine direction, and the tensile strength was lower than the vendor-ultimate strength.
- e.* Group A Com GT 500 was tested in the machine direction, and the predicted tensile strength was not reached for this fabric.
- f.* Group A K 1084 was tested in the machine direction, and the fabric exceeded the predicted tensile strength.
- g.* Group B GG was tested in the machine direction, and the material exceeded the predicted tensile strength.
- h.* Group B GG 24 was tested in the machine direction, and the material did not reach tensile strength.
- i.* Group B GG 1500 was tested in the cross machine direction, and the material did not reach maximum tensile strength.

The static tests were conducted to investigate the general performance of the retrofit system and to allow a comparison of different geogrid/geotextile fabrics. Dynamic testing must be conducted to fully determine the performance in the field.

Recommendations

General recommendations are given below for the selected geotextile and geogrid materials.

- a.* Recommend using 600 to 800 lb/in. material with 3/8-in. anchors at the lower pressure 20-psi level.
- b.* Recommend using a 10 XT geogrid instead of a 24-XT grid because it is stronger in cross-machine direction.
- c.* Recommend using the Kelvar material at the higher pressure 40-psi level.
- d.* Recommend performing further static tests on the geotextile, with a tensile strength ranging from 1,000 to 1,400 lb/in.

- e.* Before using geotextile with a tensile strength ranging from 1,715 to 3,000 lb/in., recommend making sure it is understood by designers that geotextile probably will not reach the maximum tensile strength.
- f.* Recommend designing the anchor system to match the strength of the fabric.
- g.* Make sure the anchors are embedded at the proper depth to reach the maximum strength of the anchor.
- h.* Recommend that the edges of the anchor plate are well-rounded with a smooth finish to reduce tearing of the fabric.

Bibliography

American Society for Testing and Materials. "Standard Test Method for Tensile Properties of Geotextiles by the Wide-Width Strip Method" ASTM Standard D 4595-86 (Reapproved 1994).

Huff, W. L. (1969). "Test Devices Blast Load Generator Facility," Miscellaneous Paper N-69-1, U.S. Army Engineer Waterways Experiment Station, Vicksburg, Miss.

Appendix A

Pressure and Deflections Plots

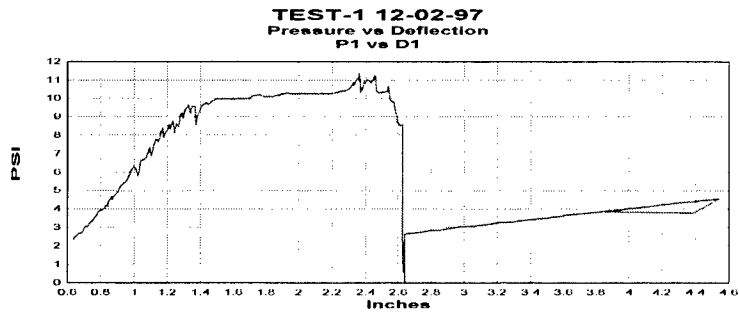

Figure A.1 Group A test 1 P1 pressure versus D1 deflection plot.

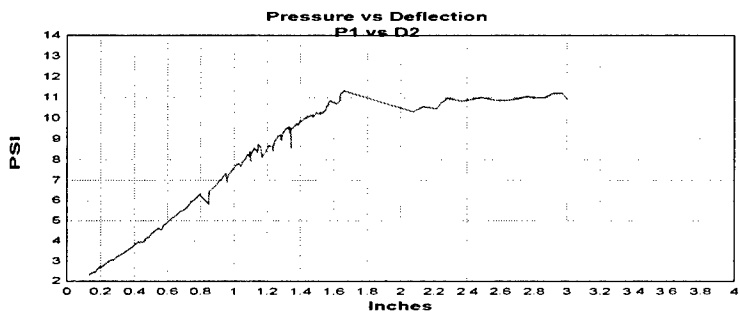

Figure A.2 Group A test 1 P1 pressure versus D2 deflection plot.

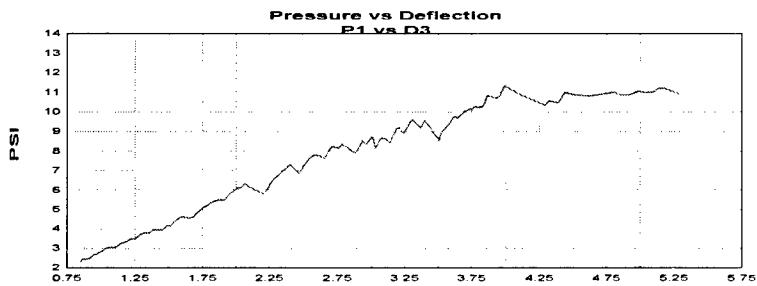

Figure A.3 Group A test 1 P1 pressure versus D3 deflection plot.

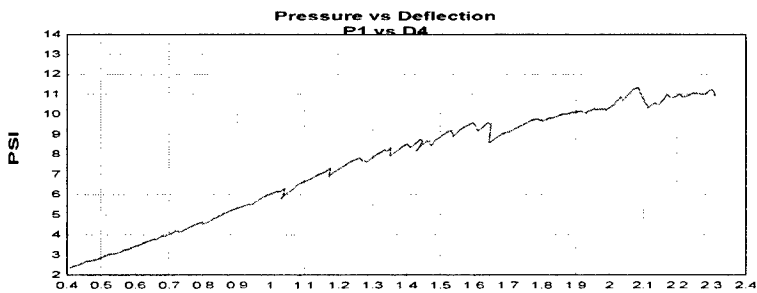

Figure A.4 Group A test 1 P1 pressure versus D4 deflection plot.

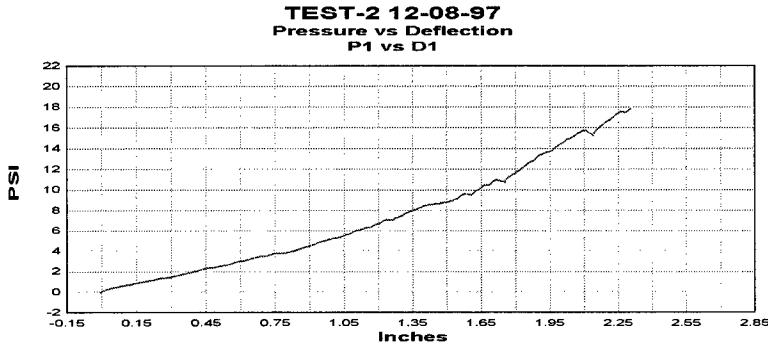

Figure A.5 Group A test 2 P1 pressure versus D1 deflection plot.

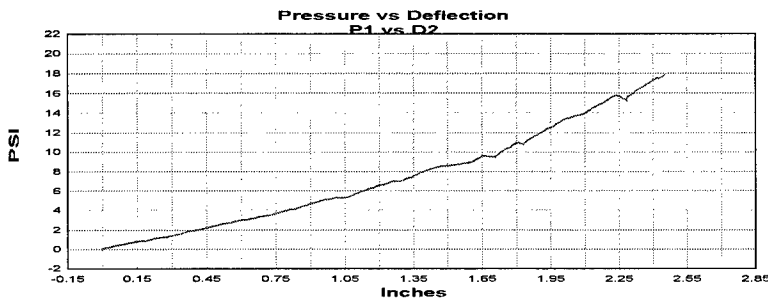

Figure A.6 Group A test 2 P1 pressure versus D2 deflection plot .

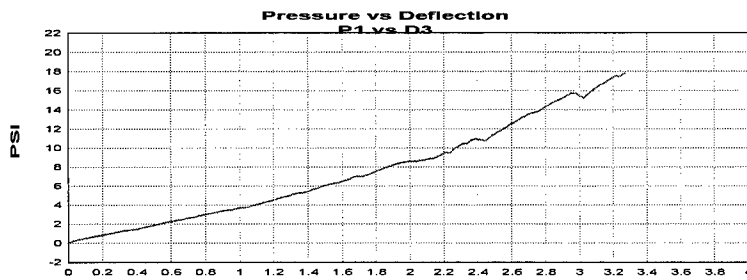

Figure A.7 Group A test 2 P1 pressure versus D3 deflection plot.

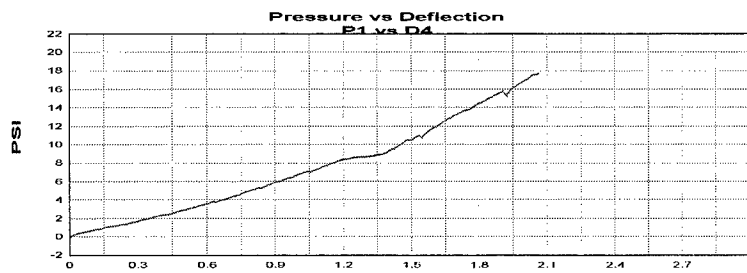

Figure A.8 Group A test 2 P1 pressure versus D4 deflection plot.

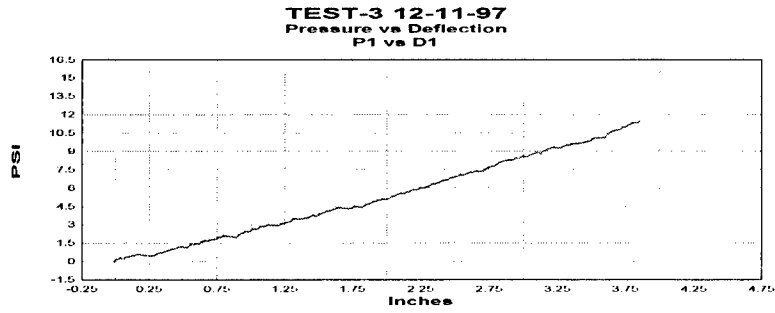

Figure A.9 Group A test 3 P1 pressure versus D1 deflection plot.

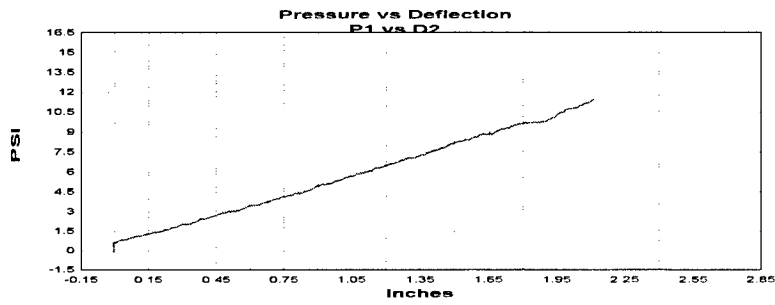

Figure A.10 Group A test 3 P1 pressure versus D2 deflection plot.

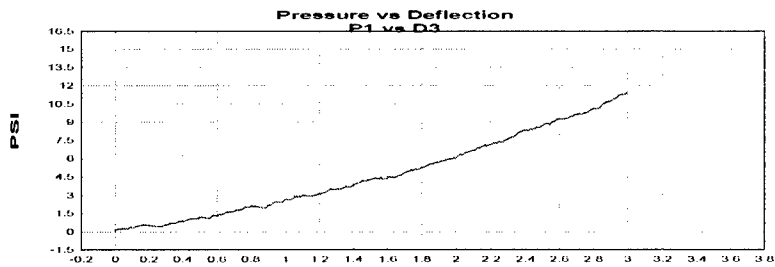

Figure A.11 Group A test 3 P1 pressure versus D3 deflection plot.

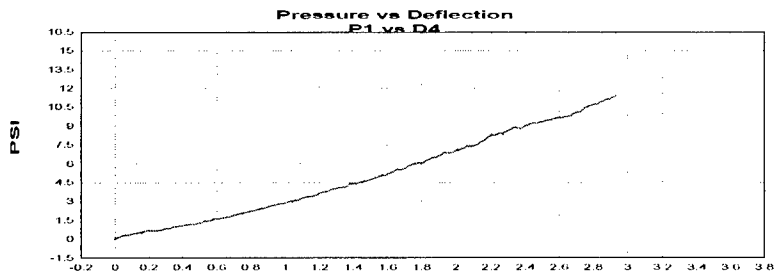

Figure A.12 Group A test 3 P1 pressure versus D4 deflection plot.

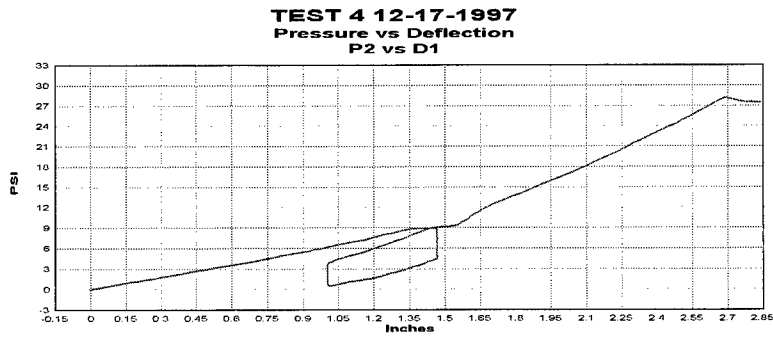

Figure A.13 Group B test 4 P2 pressure versus D1 deflection plot.

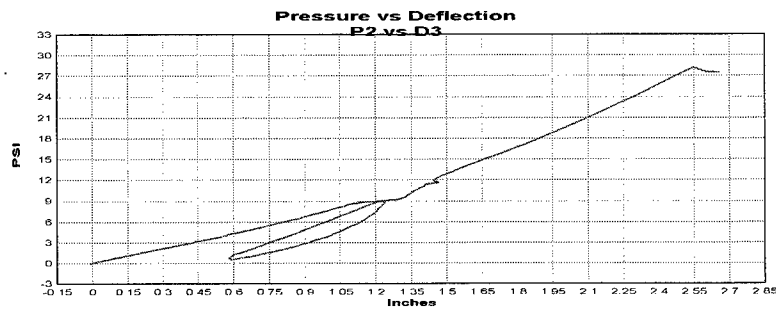

Figure A.14 Group B test 4 P2 pressure versus D3 deflection plot.

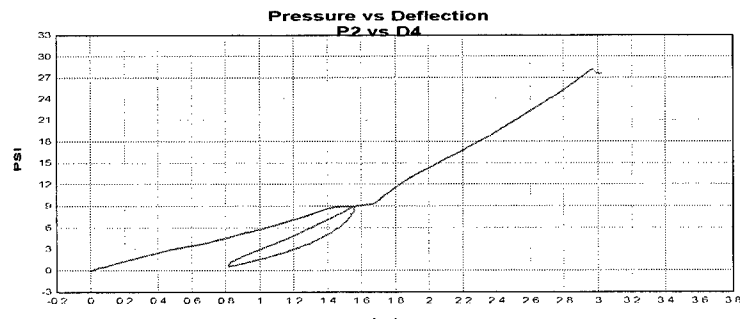

Figure A.15 Group B test 4 P2 pressure versus D4 deflection plot.

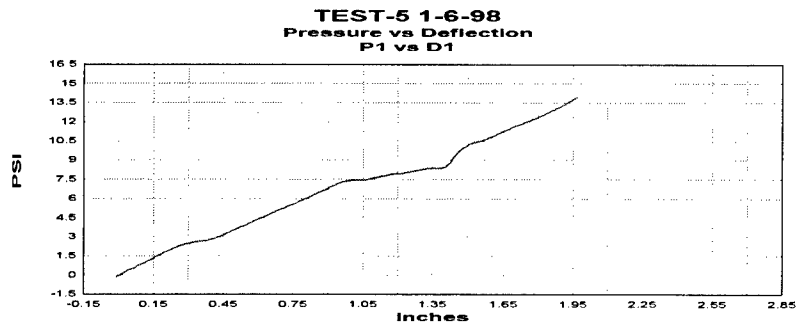

Figure A.16 Group B test 5 P1 pressure versus D1 deflection plot.

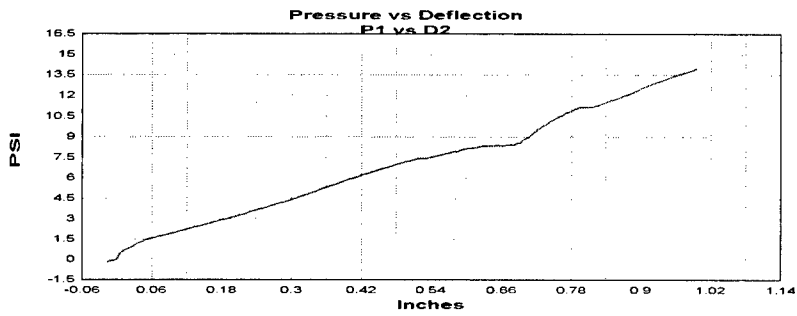

Figure A.17 Group B test 5 P1 pressure versus D2 deflection plot.

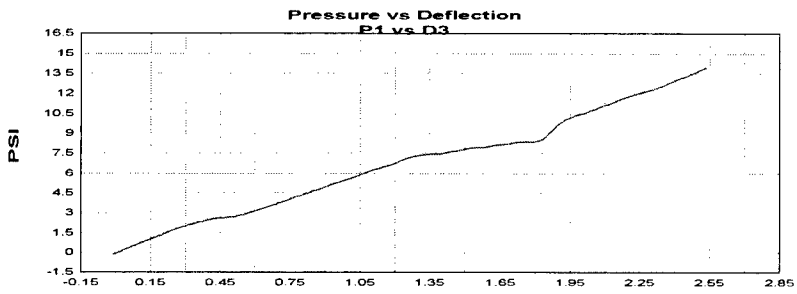

Figure A.18 Group B test 5 P1 pressure versus D3 deflection plot.

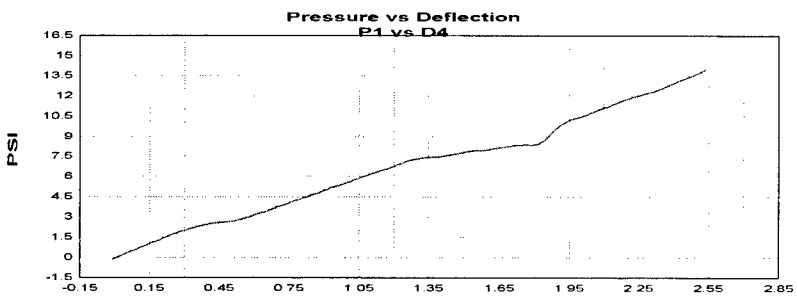

Figure A.19 Group B test 5 P1 pressure versus D4 deflection plot.

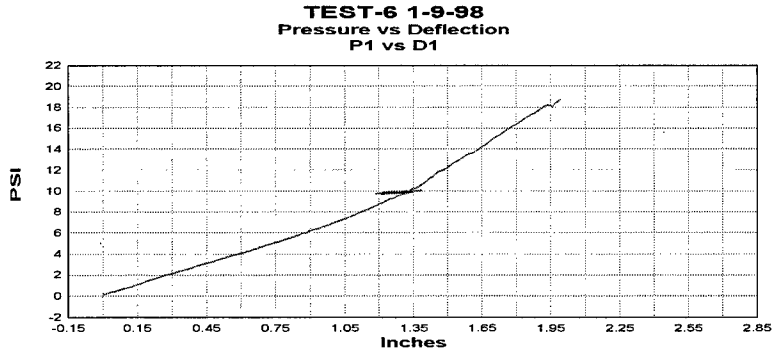

Figure A.20 Group A test 6 P1 pressure versus D1 deflection plot.

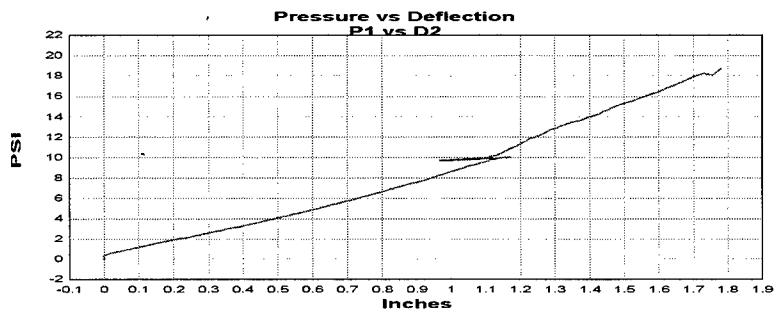

Figure A.21 Group A test 6 P1 pressure versus D2 deflection plot.

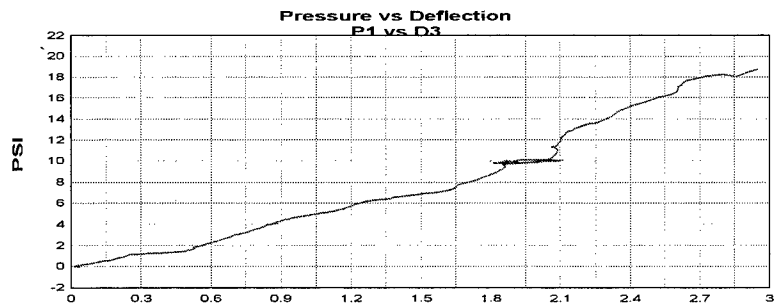

Figure A.22 Group A test 6 P1 pressure versus D3 deflection plot.

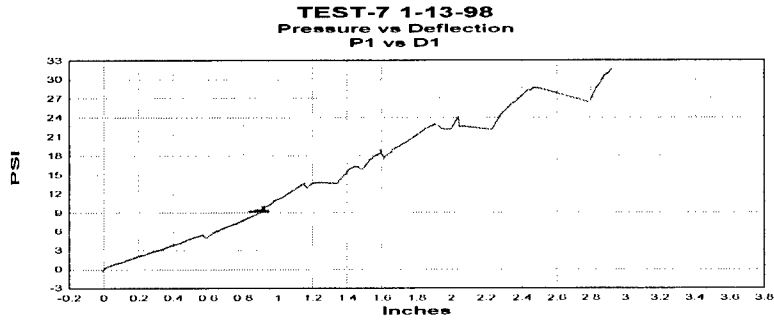

Figure A.23 Group A test 7 P1 pressure versus D1 deflection plot.

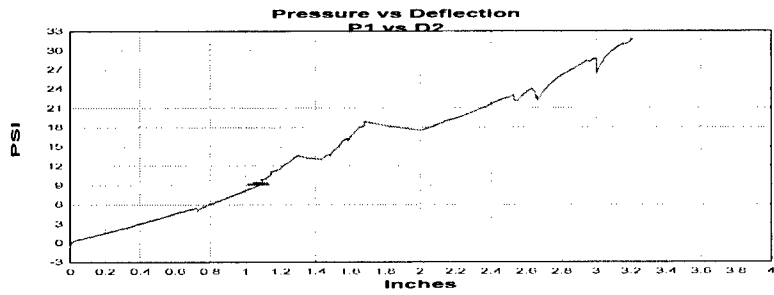

Figure A.24 Group A test 7 P1 pressure versus D2 deflection plot.

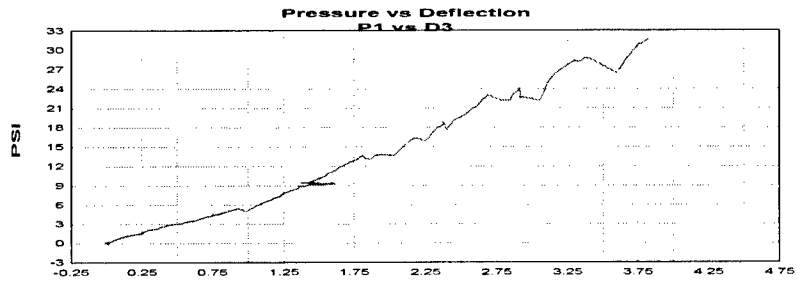

Figure A.25 Group A test 7 P1 pressure versus D3 deflection plot.

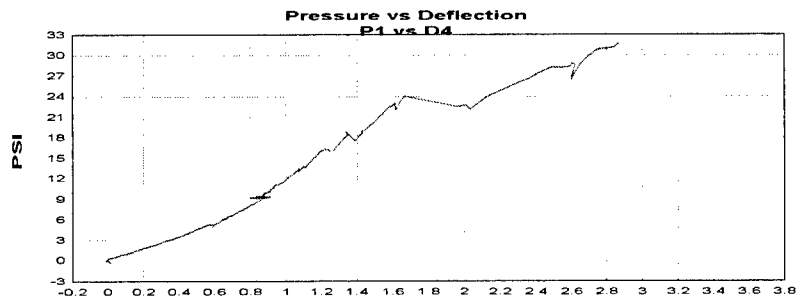

Figure A.26 Group A test 7 P1 pressure versus D4 deflection plot.

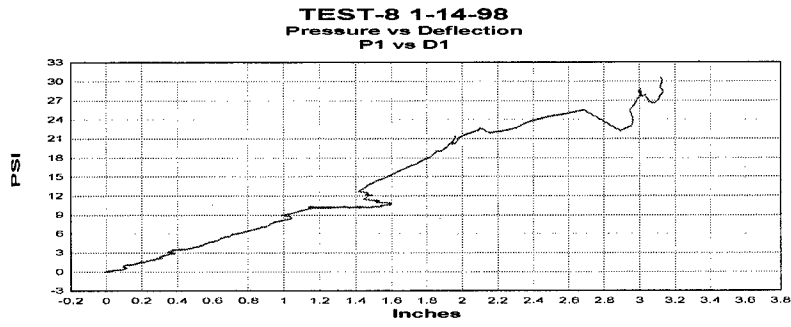

Figure A.27 Group A test 8 P1 pressure versus D1 deflection plot.

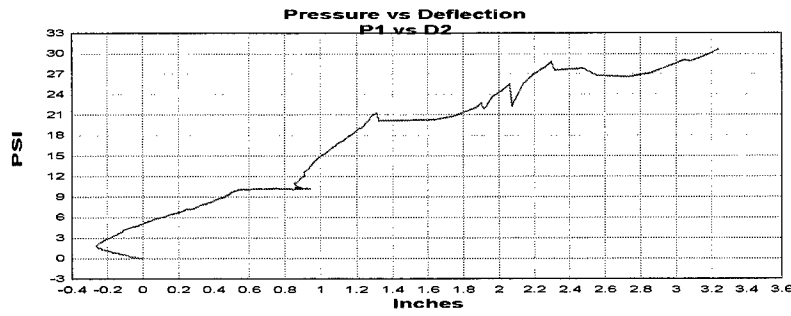

Figure A.28 Group A test 8 P1 pressure versus D2 deflection plot.

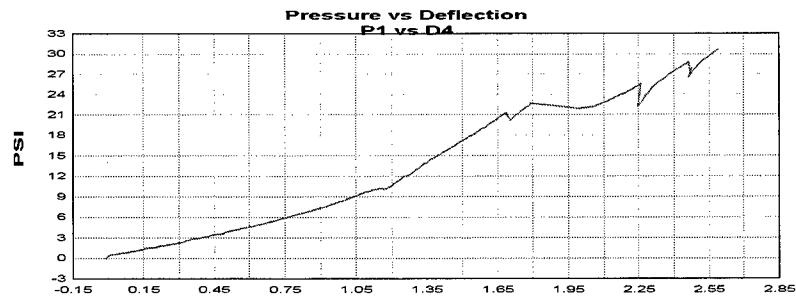

Figure A.29 Group A test 8 P1 pressure versus D4 deflection plot.

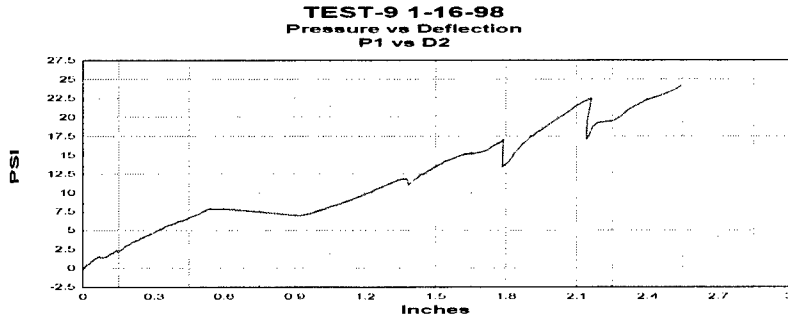

Figure A.30 Group A test 9 P1 pressure versus D2 deflection plot.

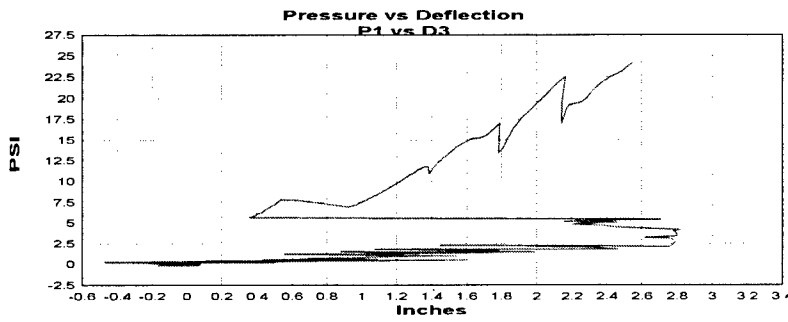

Figure A.31 Group A test 9 P1 pressure versus D3 deflection plot.

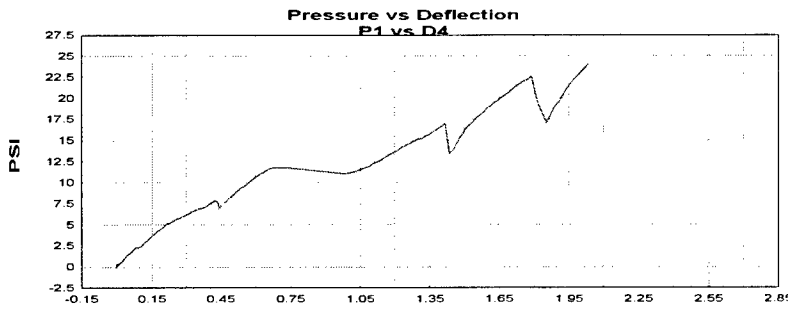

Figure A.32 Group A test 9 P1 pressure versus D4 deflection plot.

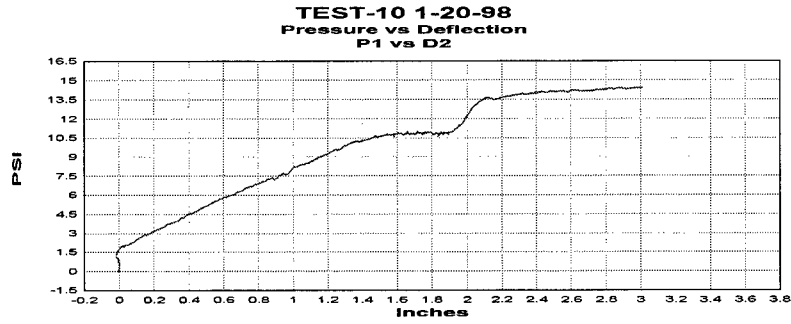

Figure A.33 Group B test 10 P1 pressure versus D2 deflection plot.

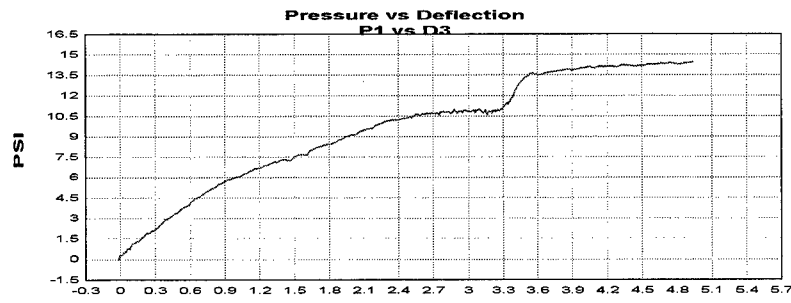

Figure A.34 Group B test 10 P1 pressure versus D3 deflection plot.

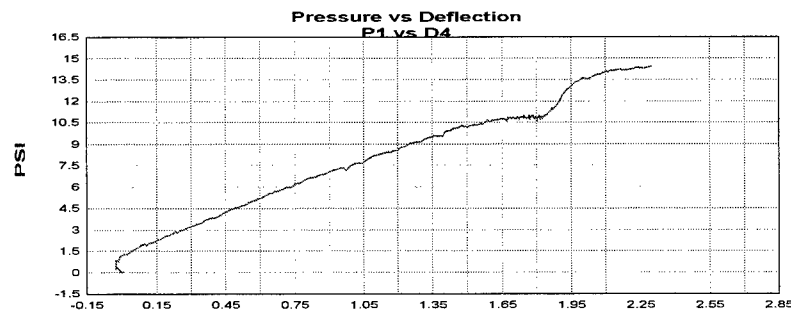

Figure A.35 Group B test 10 P1 pressure versus D4 deflection plot.

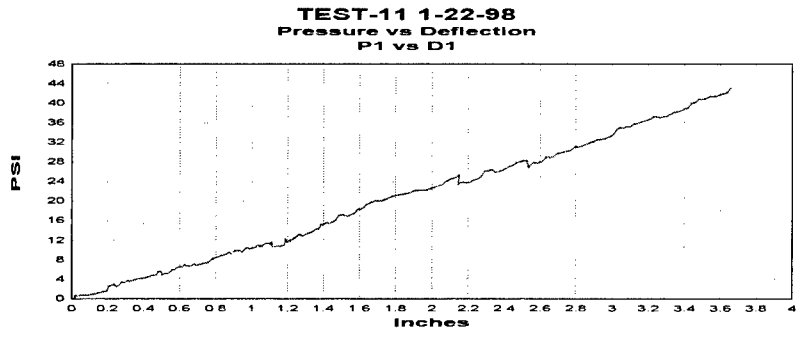

Figure A.36 Group A test 11 P1 pressure versus D1 deflection plot.

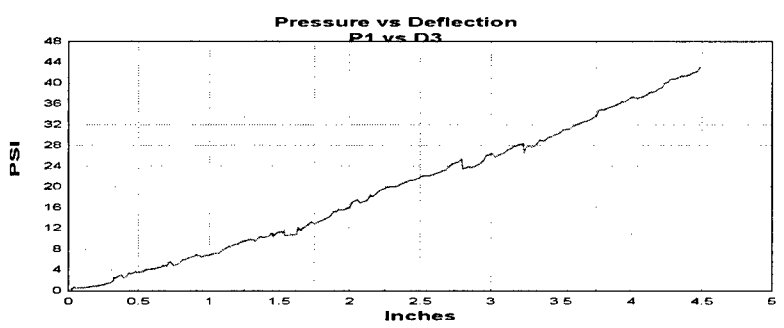

Figure A.37 Group A test 11 P1 pressure versus D3 deflection plot.

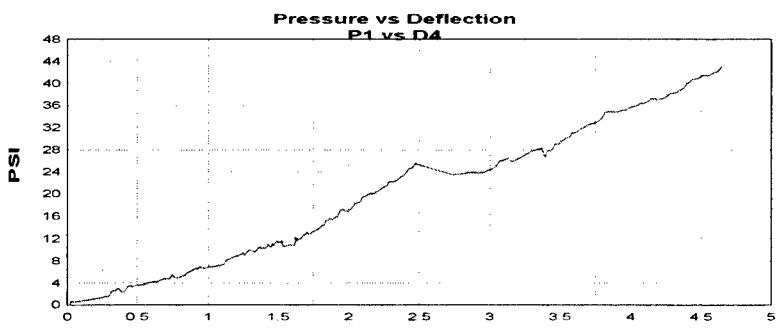

Figure A.38 Group A test 11 P1 pressure versus D4 deflection plot.

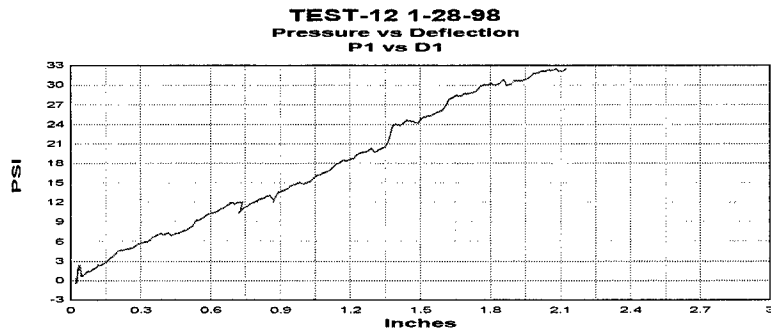

Figure A.39 Group A test 12 P1 pressure versus D1 deflection plot.

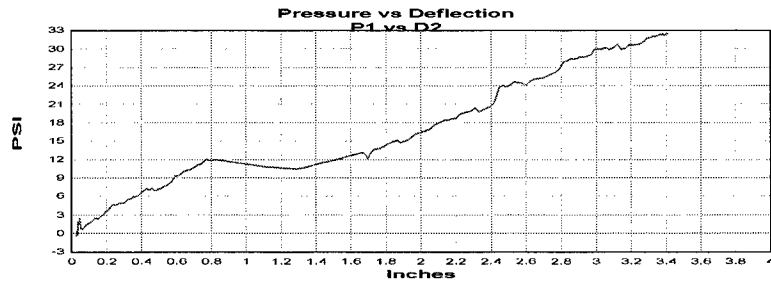

Figure A.40 Group A test 12 P1 pressure versus D2 deflection plot.

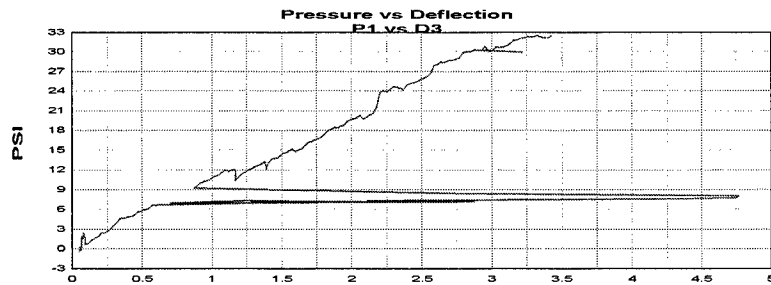

Figure A.41 Group A test 12 P1 pressure versus D3 deflection plot.

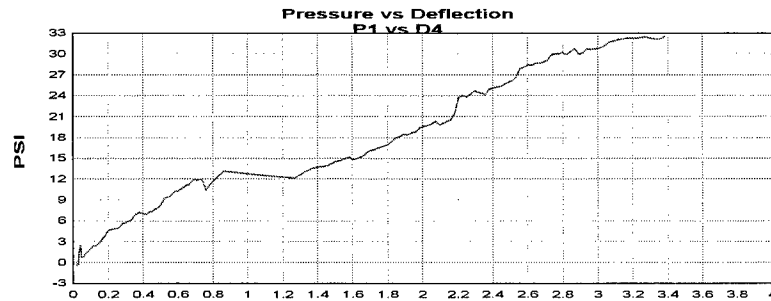

Figure A.42 Group A test 12 P1 pressure versus D4 deflection plot.

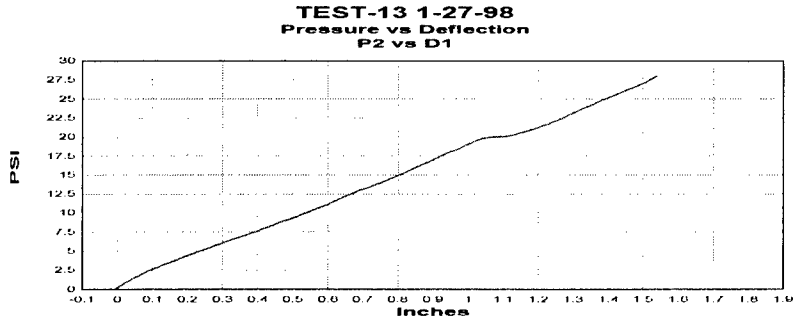

Figure A.43 Group A test 13 P2 pressure versus D1 deflection plot.

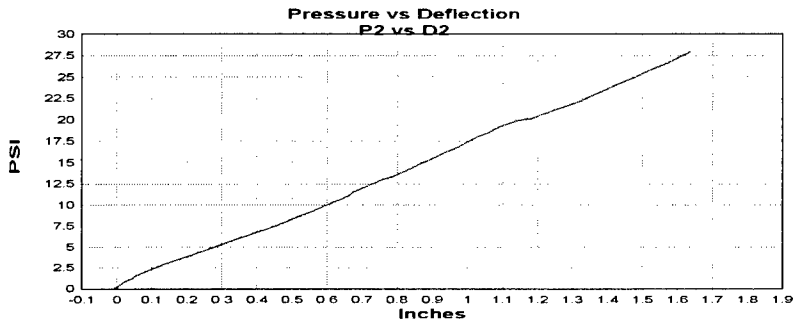

Figure A.44 Group A test 13 P2 pressure versus D2 deflection plot.

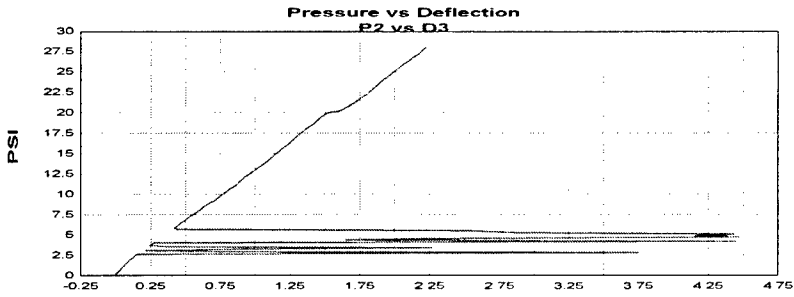

Figure A.45 Group A test 13 P2 pressure versus D3 deflection plot.

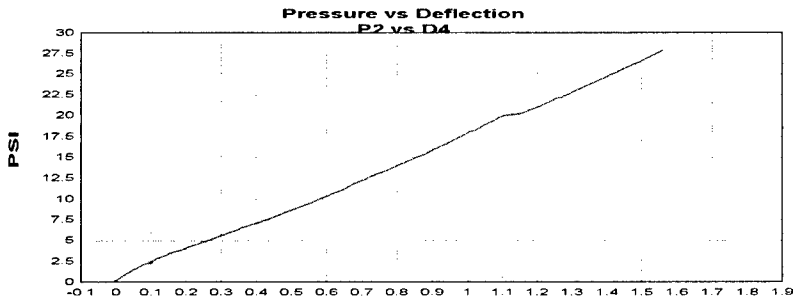

Figure A.46 Group A test 13 P2 pressure versus D4 deflection plot.

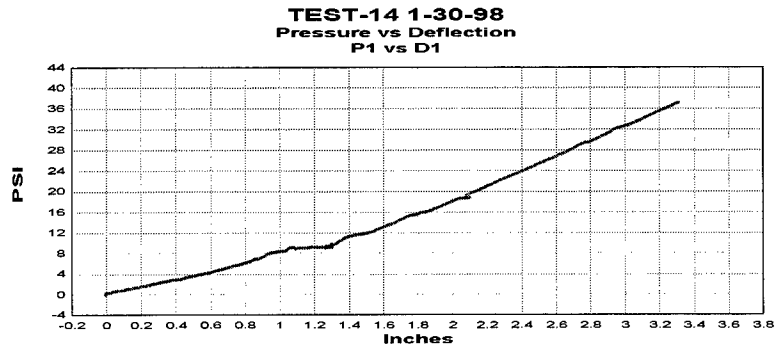

Figure A.47 Group A test 14 P1 pressure versus D1 deflection plot.

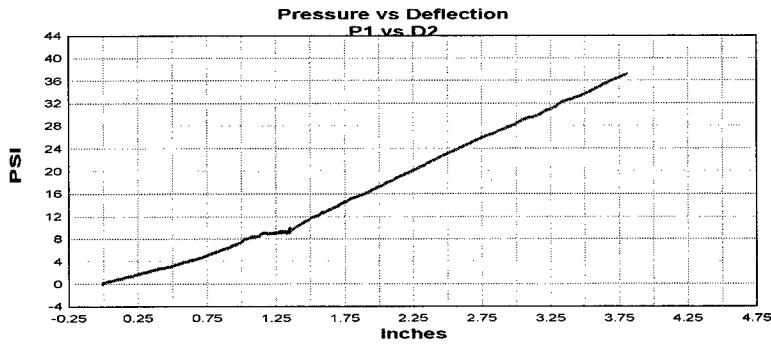

Figure A.48 Group A test 14 P1 pressure versus D2 deflection plot.

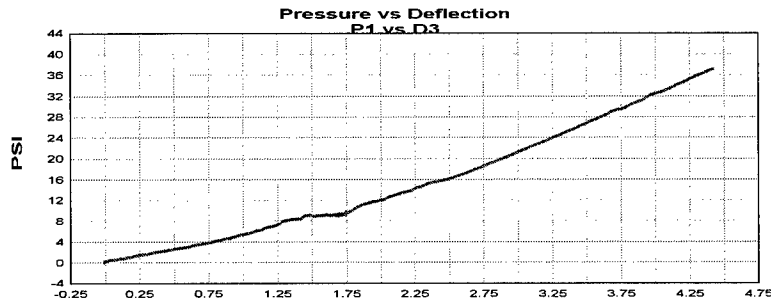

Figure A.49 Group A test 14 P1 pressure versus D3 deflection plot.

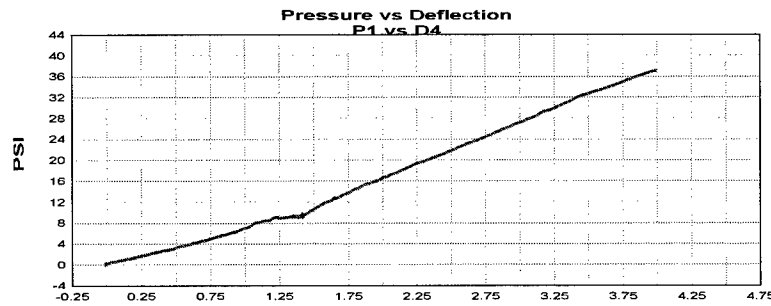

Figure A.50 Group A test 14 P1 pressure versus D4 deflection plot.

Appendix B

ASTM 4595 Manufacturers

Material Properties



TC Mirafi

Mirafi HS600

TECHNICAL DATA SHEET

Mirafi HS600 is composed of high tenacity polyester multifilament yarns which are woven into a stable network such that the yarns retain their relative position. HS600 is inert to biological degradation and resistant to naturally encountered chemicals, alkalis, and acids.

Mechanical Properties	Test Method	Unit	Minimum Average
			Roll Value
Tensile Strength (at ultimate)	ASTM D 4595	kN/m (lbs/ft)	105.1 (7200)
Tensile Strength (at 5% strain)	ASTM D 4595	kN/m (lbs/ft)	29.8 (2040)
Tensile Strength (at 10% strain)	ASTM D 4595	kN/m (lbs/ft)	84.0 (5760)
Creep Reduced Strength	ASTM D 5262	kN/m (lbs/ft)	63.0 (4320)
Long Term Design Strength*	GRI GT-7	kN/m (lbs/ft)	49.8 (3415)
Factory Seam Strength	ASTM D 4884	kN/m (lbs/ft)	35.0 (2400)
Permittivity	ASTM D 4491	sec ⁻¹	0.32
Apparent Opening Size (AOS)	ASTM D 4751	mm (U.S. Sieve)	0.850 (20)
UV Resistance (at 500 hours)	ASTM D 4355	% strength retained	70

* Long Term Allowable Design values are for sand, silt and clay.

NOTE: To obtain Secant Modulus, divide tensile strength by the appropriate strain level
(i.e. Secant Modulus at 5% = 2040/0.05 = 40,800 lb/ft)

Physical Properties	Test Method	Unit	Typical Value
Mass/Unit Area	ASTM D 5261	g/m ² (oz/yd ²)	408 (12.2)
Roll Dimensions (length x width)	--	m (ft)	4.5 (15) x 91.5 (300)
Roll Area	--	m ² (yd ²)	418.0 (500)
Estimated Roll Weight	---	kg (lbs)	180 (400)

DISCLAIMER: TC Mirafi warrants our products to be free from defects in material and workmanship when delivered to TC Mirafi's customers and that our products meets our published specifications. Contact your local TC Mirafi Representative for detailed product specification and warranty information.



TC Mirafi
Mirafi HS800

TECHNICAL DATA SHEET

Mirafi HS800 is composed of high tenacity polyester multifilament yarns which are woven into a stable network such that the yarns retain their relative position. HS800 is inert to biological degradation and resistant to naturally encountered chemicals, alkalis, and acids.

Mechanical Properties	Test Method	Unit	Minimum Average
			Roll Value Machine Direction
Tensile Strength (at ultimate)	ASTM D 4595	kN/m (lbs/ft)	140.1 (9600)
Tensile Strength (at 5% strain)	ASTM D 4595	kN/m (lbs/ft)	52.5 (3600)
Tensile Strength (at 10% strain)	ASTM D 4595	kN/m (lbs/ft)	140.1 (9600)
Creep Reduced Strength	ASTM D 5262	kN/m (lbs/ft)	84.0 (5760)
Long Term Design Strength*	GRI GT-7	kN/m (lbs/ft)	66.4 (4553)
Factory Seam Strength	ASTM D 4884	kN/m (lbs/ft)	35.0 (2400)
Permittivity	ASTM D 4491	sec ⁻¹	0.200
Apparent Opening Size (AOS)	ASTM D 4751	mm (U.S. Sieve)	0.850 (20)
UV Resistance (at 500 hours)	ASTM D 4355	% strength retained	70

* Long Term Allowable Design values are for sand, silt and clay.

NOTE: To obtain Secant Modulus, divide tensile strength by the appropriate strain level
(i.e. Secant Modulus at 5% = 3600/0.05 = 72,000 lb/ft)

Physical Properties	Test Method	Unit	Typical Value
Mass/Unit Area	ASTM D 5261	g/m ² (oz/yd ²)	504 (15.1)
Roll Dimensions (width x length)	--	m (ft)	4.5 (15) x 91.5 (300)
Roll Area	--	m ² (yd ²)	418.0 (500)
Estimated Roll Weight	---	kg (lbs)	221 (490)

DISCLAIMER: TC Mirafi warrants our products to be free from defects in material and workmanship when delivered to TC Mirafi's customers and that our products meets our published specifications. Contact your local TC Mirafi Representative for detailed product specification and warranty information.



TC Mirafi
Mirafi HS1715

TECHNICAL DATA SHEET

Mirafi HS1715 is composed of high tenacity polyester multifilament yarns which are woven into a stable network such that the yarns retain their relative position. HS1715 is inert to biological degradation and resistant to naturally encountered chemicals, alkalis, and acids.

Mechanical Properties	Test Method	Unit	Minimum Average
			Roll Value
Tensile Strength (at ultimate)	ASTM D 4595	kN/m (lbs/ft)	300.4 (20580)
Tensile Strength (at 5% strain)	ASTM D 4595	kN/m (lbs/ft)	122.6 (8400)
Tensile Strength (at 10% strain)	ASTM D 4595	kN/m (lbs/ft)	236.5 (16200)
Creep Reduced Strength	ASTM D 5262	kN/m (lbs/ft)	180.2 (12348)
Long Term Design Strength*	GRI GT-7	kN/m (lbs/ft)	148.9 (10205)
Factory Seam Strength	ASTM D 4884	kN/m (lbs/ft)	35.0 (2400)
Permittivity	ASTM D 4491	sec ⁻¹	0.32
Apparent Opening Size (AOS)	ASTM D 4751	mm (U.S. Sieve)	0.850 (20)
UV Resistance (at 500 hours)	ASTM D 4355	% strength retained	70

* Long Term Allowable Design values are for sand, silt and clay.

NOTE: To obtain Secant Modulus, divide tensile strength by the appropriate strain level
(i.e. Secant Modulus at 5% = 8400/0.05 = 168,000 lb/ft)

Physical Properties	Test Method	Unit	Typical Value
Mass/Unit Area	ASTM D 5261	g/m ² (oz/yd ²)	925 (27.7)
Roll Dimensions (width x length)	--	m (ft)	4.5 (15) x 91.5 (300)
Roll Area	--	m ² (yd ²)	418.0 (500)
Estimated Roll Weight	---	kg (lbs)	400 (890)

DISCLAIMER: TC Mirafi warrants our products to be free from defects in material and workmanship when delivered to TC Mirafi's customers and that our products meets our published specifications. Contact your local TC Mirafi Representative for detailed product specification and warranty information.



TECHNICAL DATA SHEET

Mirafi Miragrid® 10XT

Mirafi Miragrid® 10XT is composed of high molecular weight, high tenacity polyester multifilament yarns which are woven in tension and finished with a pvc coating. Miragrid® 10XT is inert to biological degradation and resistant to naturally encountered chemicals, alkalis, and acids.

Mechanical Properties	Test Method	Unit	Minimum Average
			Roll Value
Tensile Strength (at ultimate)	ASTM D 4595	kN/m (lbs/ft)	121.1 (8300)
Tensile Strength (at 5% strain)	ASTM D 4595	kN/m (lbs/ft)	45.5 (3120)
Creep Reduced Strength	ASTM D 5262	kN/m (lbs/ft)	72.7 (4980)
Long Term Allowable Design Load*	GRI GG-4	kN/m (lbs/ft)	60.1 (4116)

* NOTE: Long Term Allowable Design values are for sand, silt and clay.

Physical Properties	Test Method	Unit	Typical Value
Grid Aperture Size (machine direction)	--	mm (in)	27 (1.1)
Grid Aperture Size (cross machine direction)	--	mm (in)	15 (0.625)
Mass/Unit Area	ASTM D 5261	g/m ² (oz/yd ²)	424 (12.5)
Roll Dimensions (length x width)	--	m (ft)	3.3 (10.83) x 61 (200)
Roll Area	--	m ² (yd ²)	201.2 (240.7)
Estimated Roll Weight	---	kg (lbs)	82.6 (182)

DISCLAIMER: TC Mirafi warrants our products to be free from defects in material and workmanship when delivered to TC Mirafi's customers and that our products meet our published specifications. Contact your local TC Mirafi Representative for detailed product specification and warranty information.



TECHNICAL DATA SHEET

Mirafi Miragrid® 24XT

Mirafi Miragrid® 24XT is composed of high molecular weight, high tenacity polyester multifilament yarns which are woven in tension and finished with a pvc coating. Miragrid® 24XT is inert to biological degradation and resistant to naturally encountered chemicals, alkalis, and acids.

Mechanical Properties	Test Method	Unit	Minimum Average Roll Value
			Machine Direction
Tensile Strength (at ultimate)	ASTM D 4595	kN/m (lbs/ft)	370.3 (25380)
Tensile Strength (at 5% strain)	ASTM D 4595	kN/m (lbs/ft)	146.2 (10020)
Creep Reduced Strength	ASTM D 5262	kN/m (lbs/ft)	215.3 (14756)
Long Term Allowable Design Load*	GRI GG-4	kN/m (lbs/ft)	177.9 (12195)

* NOTE: Long Term Allowable Design values are for sand, silt and clay.

Physical Properties	Test Method	Unit	Typical Value
Grid Aperture Size (machine direction)	--	mm (in)	81 (3.2)
Grid Aperture Size (cross machine direction)	--	mm (in)	5.1 (0.2)
Mass/Unit Area	ASTM D 5261	g/m ² (oz/yd ²)	1492 (44)
Roll Dimensions (length x width)	--	m (ft)	1.9 (6.4) x 45.7 (150)
Roll Area	--	m ² (yd ²)	89.1 (106.7)
Estimated Roll Weight	---	kg (lbs)	114.8 (253)

DISCLAIMER: TC Mirafi warrants our products to be free from defects in material and workmanship when delivered to TC Mirafi's customers and that our products meet our published specifications. Contact your local TC Mirafi Representative for detailed product specification and warranty information.



COMTRAC 500.70 HIGH STRENGTH GEOTEXTILE

PRODUCT DESCRIPTION

Comtrac 500.70 is a woven fabric manufactured by Huesker and comprised of polyester yarns which are woven into a stable network such that the yarns retain their relative positions. The fabric is inert to biological degradation and naturally encountered chemicals, alkalis, and acids. Comtrac 500.70 conforms to the minimum average roll values listed in the following table.

<u>FABRIC PROPERTY</u>	<u>UNIT</u>	<u>TEST METHOD</u>	<u>MINIMUM AVERAGE ROLL VALUES¹</u>
Fabric Width	ft	-	16.5
Weight	oz/yd ²	Measured	30
Wide Width Tensile Strength	lb/in	ASTM D-4595	
• Warp Direction			
@5%			1050
@Ultimate			2800
• Fill Direction			
@Ultimate ^c			400
Wide Width Tensile Elongation	%	ASTM D-4595	12 X 12
Puncture Strength	lb	ASTM D-4833	400
Burst Strength	psi	ASTM D-3786	1350
A.O.S.	U.S. Std. Sieve	ASTM D-4751	40-70
U.V. Resistance (150 Hrs.)	%	ASTM D-4355	70%

¹Minimum average roll values are based on a 95% confidence level.



COMTRAC 350.125 HIGH STRENGTH GEOTEXTILE

PRODUCT DESCRIPTION

Comtrac 350.125 is a woven fabric manufactured by Huesker and comprised of polyester yarns which are woven into a stable network such that the yarns retain their relative positions. The fabric is inert to biological degradation and naturally encountered chemicals, alkalies, and acids. Comtrac 350.125 conforms to the minimum average roll values listed in the following table.

<u>FABRIC PROPERTY</u>	<u>UNIT</u>	<u>TEST METHOD</u>	<u>MINIMUM AVERAGE ROLL VALUES¹</u>
Fabric Width	ft	-	16.5
Weight	oz/yd ²	Measured	25
Wide Width Tensile Strength	lb/in	ASTM D-4595	
• Warp Direction			
@5%			750
@Ultimate			2000
• Fill Direction			
@Ultimate			715
Wide Width Tensile Elongation	%	ASTM D-4595	12 X 12
Puncture Strength	lb	ASTM D-4833	300
Burst Strength	psi	ASTM D-3786	1250
A.O.S.	U.S. Std. Sieve	ASTM D-4751	40-70
U.V. Resistance (150 Hrs.)	%	ASTM D-4355	70%

¹Minimum average roll values are based on a 95% confidence level.

Long Term Design Strength Determination of Tensar Structural Geogrids
Using the GRI:GR4 Method

	BX1200	UX1100SB	UX1100HS	UX1400SB	UX1400HS	UX1500SB	UX1500HS	UX1600SD	UX1600HS	UX1700HS
Ultimate Strength lbs/ft GRI-GGI ¹	2100	2650	2700	3700	4400	6300	3900	7540	9000	10800
Creep Limited Strength ² (lb/ft)	555	900	935	1400	1850	2300	2800	3000	2700	4650
F. S. Construction Damage										
Sand, Silt, & Clay	1.10	1.05	1.05	1.05	1.05	1.05	1.05	1.05	1.05	1.05
¾" Minus Angular Aggr.	1.10	1.06	1.12	1.05	1.12	1.08	1.15	1.05	1.19	1.08
1½" Minus Angular Aggr.	1.17	1.20	1.18	1.18	1.32	1.16	1.20	1.17	1.23	1.22
P.S. Junction Strength	1.00	1.00	1.00	1.00	1.00	1.00	1.00	1.00	1.00	1.00

Long-Term Allowable Design Strengths of Tensar Geogrids³ – Private Market

	BX1200	UX1100SB	UX1100HS	UX1400SB	UX1400HS	UX1500SB	UX1500HS	UX1600SD	UX1600HS	UX1700HS
F. S. Durability = 1.0 (Private Mkt)										
Sand, Silt, & Clay	505	857	890	1333	1762	2190	2667	2857	3524	4429
¾" Minus Angular Aggr.	505	849	835	1333	1652	2130	2435	2857	3109	4306
1½" Minus Angular Aggr.	474	750	792	1186	1402	1983	2333	2564	3008	3811

Long-Term Allowable Design Strengths for Tensar Geogrids³ – Public Market

	BX1200	UX1100SB	UX1100HS	UX1400SB	UX1400HS	UX1500SB	UX1500HS	UX1600SD	UX1600HS	UX1700HS
F. S. Durability = 1.1 (Public Mkt)										
Sand, Silt, & Clay	459	779	809	1212	1602	1991	2424	2597	3203	4026
¾" Minus Angular Aggr.	459	772	759	1212	1502	1936	2213	2597	2827	3914
1½" Minus Angular Aggr.	431	682	720	1079	1274	1803	2121	2331	2735	3465

¹Tested at 10% per minute on a 2 aperture gage length. ²Based on a strain limit of 10%. ³A factor of safety for uncertainties must be included for some design methodologies.

Appendix C

ASTM 4595 Material Properties



Designation: D 4595 - 86 (Reapproved 1994)

AMERICAN SOCIETY FOR TESTING AND MATERIALS
1816 Race St. Philadelphia, Pa 19103
Reprinted from the Annual Book of ASTM Standards. Copyright ASTM
If not listed in the current combined index, will appear in the next edition

Standard Test Method for Tensile Properties of Geotextiles by the Wide-Width Strip Method¹

This standard is issued under the fixed designation D 4595; the number immediately following the designation indicates the year of original adoption or, in the case of revision, the year of last revision. A number in parentheses indicates the year of last reapproval. A superscript epsilon (ϵ) indicates an editorial change since the last revision or reapproval.

1. Scope

1.1 This test method covers the measurement of tensile properties of geotextiles using a wide-width strip specimen tensile method. This test method is applicable to most geotextiles that include woven fabrics, nonwoven fabrics, layered fabrics, knit fabrics, and felts that are used for geotextile application.

1.2 This test method covers the measurement of tensile strength and elongation of geotextiles and includes directions for the calculation of initial modulus, offset modulus, secant modulus, and breaking toughness.

1.3 Procedures for measuring the tensile properties of both conditioned and wet geotextiles by the wide-width strip method are included.

1.4 The basic distinction between this test method and other methods for measuring strip tensile properties is the width of the specimen. This width, by contrast, is greater than the length of the specimen. Some fabrics used in geotextile applications have a tendency to contract (neck down) under a force in the gage length area. The greater width of the specimen specified in this test method minimizes the contraction effect of those fabrics and provides a closer relationship to expected geotextile behavior in the field and a standard comparison.

1.5 *This standard does not purport to address all of the safety concerns, if any, associated with its use. It is the responsibility of the user of this standard to establish appropriate safety and health practices and determine the applicability of regulatory limitations prior to use.*

2. Referenced Documents

- 2.1 *ASTM Standards:*
- D76 Specification for Tensile Testing Machines for Textiles²
- D123 Definitions of Terms Relating to Textiles²
- D579 Specification for Greige Woven Glass Fabrics²
- D1776 Practice for Conditioning Textiles for Testing²
- D2905 Practice for Statements on Number of Specimens for Textiles²
- D4439 Terminology for Geosynthetics³

3. Terminology

- 3.1 *atmosphere for testing geotextiles, n*—air maintained

¹This test method is under the jurisdiction of ASTM Committee D-35 on Geosynthetics and is the direct responsibility of Subcommittee D35.01 on

at a relative humidity of $65 \pm 5\%$ and a temperature of $21 \pm 2^\circ\text{C}$ ($70 \pm 4^\circ\text{F}$).

3.2 *breaking toughness, T , (FL^{-1}), Jm^{-2} , n* —for geotextiles, the actual work-to-break per unit surface area of material.

3.2.1 *Discussion*—Breaking toughness is proportional to the area under the force – elongation curve from the origin to the breaking point (see also work-to-break). Breaking toughness is calculated from work-to-break, gage length, and width of a specimen.

3.3 *corresponding force, F_c , n* —the force associated with a specific elongation on the force-per-unit-width strain curve. (Syn. load at specified elongation, LASE.)

3.4 *geotechnical engineering, n*—the engineering application of geotechnics.

3.5 *geotechnics, n*—the application of scientific methods and engineering principles to the acquisition, interpretation, and use of knowledge of materials of the earth's crust to the solution of engineering problems.

3.5.1 *Discussion*—Geotechnics embraces the fields of soil mechanics, rock mechanics, and many of the engineering aspects of geology, geophysics, hydrology, and related sciences.

3.6 *geotextile, n*—any permeable textile material used with foundation, soil, rock, earth, or any other geotechnical engineering related material, as an integral part of a man-made project, structure, or system.

3.7 *initial tensile modulus, J_0 , (FL^{-1}), Nm^{-1} , n* —for geotextiles, the ratio of the change in tensile force per unit width to a change in strain (slope) of the initial portion of a force per unit width strain curve.

3.8 *offset tensile modulus, J_o , (FL^{-1}), Nm^{-1} , n* —for geotextiles, the ratio of the change in force per unit width to a change in strain (slope) below the proportional limit point and above the tangent point on the force – elongation curve.

3.9 *proportional limit, n*—the greatest stress which a material is capable of sustaining without any deviation from proportionality of stress to strain (Hooke's law).

3.10 *secant tensile modulus, J_{sec} , (FL^{-1}), Nm^{-1} , n* —for geotextiles, the ratio of change in force per unit width to a change in strain (slope) between two points on a force per unit width strain curve.

3.11 *tangent point, n*—for geotextiles, the first point of the force – elongation curve at which a major decrease in slope occurs.

3.11.1 *Discussion*—The tangent point is determined by drawing a tangent line passing through the zero axis and the

3.12 *tensile modulus*, J , (FL^{-1}), Nm^{-1} , n .—for geotextiles, the ratio of the change in tensile force per unit width to a corresponding change in strain (slope).

3.13 *tensile strength*, n .—for geotextiles, the maximum resistance to deformation developed for a specific material when subjected to tension by an external force.

3.13.1 *Discussion*—Tensile strength of geotextiles is the characteristic of a sample as distinct from a specimen and is expressed in force per unit width.

3.14 *tensile test*, n .—in textiles, a test in which a textile material is stretched in one direction to determine the force — elongation characteristics, the breaking force, or the breaking elongation.

3.15 *wide-width strip tensile test*, n .—for geotextiles, a uniaxial tensile test in which the entire width of a 200-mm (8.0-in.) wide specimen is gripped in the clamps and the gage length is 100 mm (4.0 in.).

3.16 *work-to-break*, W , (LF), n .—in tensile testing, the total energy required to rupture a specimen.

3.16.1 *Discussion*—For geotextiles, work-to-break is proportional to the area under the force — elongation curve from the origin to the breaking point, and is commonly expressed in joules (inch-pound-force).

3.17 *yield point*, n .—the first point of the force — elongation curve above the proportional (linear) section at which an increase in elongation occurs without a corresponding increase in force.

3.18 For terminology of other terms used in this test method, refer to Terminology D 123 and Terminology D 4439.

4. Summary of Method

4.1 A relatively wide specimen is gripped across its entire width in the clamps of a constant rate of extension (CRE) type tensile testing machine operated at a prescribed rate of extension, applying a longitudinal force to the specimen until the specimen ruptures. Tensile strength, elongation, initial and secant modulus, and breaking toughness of the test specimen can be calculated from machine scales, dials, recording charts, or an interfaced computer.

5. Significance and Use

5.1 The determination of the wide-width strip force — elongation properties of geotextiles provides design parameters for reinforcement type applications, for example design of reinforced embankments over soft subgrades, reinforced soil retaining walls, and reinforcement of slopes. When strength is not necessarily a design consideration, an alternative test method may be used for acceptance testing. Test Method D 4595 for the determination of the wide-width strip tensile properties of geotextiles may be used for the acceptance testing of commercial shipments of geotextiles but caution is advised since information about between-laboratory precision is incomplete (Note 6). Comparative tests as directed in 5.1.1 may be advisable.

5.1.1 In cases of a dispute arising from differences in reported test results when using Test Method D 4595 for acceptance testing of commercial shipments, the purchaser and the supplier should conduct comparative tests to determine if there is a statistical bias between their laboratories. Competent statistical assistance is recommended for the

investigation of bias. As a minimum, the two parties should take a group of test specimens which are as homogeneous as possible and which are from a lot of material of the type in question. The test specimens should then be randomly assigned in equal numbers to each laboratory for testing. The average results from the two laboratories should be compared using Student's t -test for unpaired data and an acceptable probability level chosen by the two parties before the testing began. If a bias is found, either its cause must be found and corrected or the purchaser and the supplier must agree to interpret future test results in the light of the known bias.

5.2 Most geotextiles can be tested by this test method. Some modification of clamping techniques may be necessary for a given geotextile depending upon its structure. Special clamping adaptations may be necessary with strong geotextiles or geotextiles made from glass fibers to prevent them from slipping in the clamps or being damaged as a result of being gripped in the clamps. Specimen clamping may be modified as required at the discretion of the individual laboratory providing a representative tensile strength is obtained. In any event, the procedure described in Section 10 of this test method for obtaining wide-width strip tensile strength must be maintained.

5.3 This test method is applicable for testing geotextiles either dry or wet. It is used with a constant rate of extension type tension apparatus.

5.4 The use of tensile strength test methods that restrict the *clamped* width dimension to 50 mm (2 in.) or less, such as the ravel, cut strip, and grab test procedures, have been found less suitable than this test method for determining design strength parameters for some geotextiles. This is particularly the case for nonwoven geotextiles. The wide-width strip technique has been explored by the industry and is recommended in these cases for geotextile applications.

5.4.1 This test method may not be suited for some woven fabrics used in geotextile applications that exhibit strengths approximately 100 kN/m or 600 lbf/in. due to clamping and equipment limitations. In those cases, 100-mm (4-in.) width specimens may be substituted for 200-mm (8-in.) width specimens. On those fabrics, the contraction effect cited in 1.4 is minimal and, consequently, the standard comparison can continue to be made.

6. Apparatus and Reagents

6.1 *Tensile Testing Machine*—A constant rate of extension (CRE) type of testing machine described in Specification D 76 shall be used. When using the CRE type tensile tester, the recorder must have adequate pen response to properly record the force—elongation curve as specified in Specification D 76.

6.2 *Clamps*—The clamps shall be sufficiently wide to grip the entire width of the sample and with appropriate clamping power to prevent slipping or crushing (damage).

6.2.1 Two basic clamp designs are shown in Figs. 1, 2, 3, and 4. These designs have been used in the laboratory and have provided reproducible tensile strengths. These clamps may be modified to provide greater ease and speed of clamping. In any event, caution must be taken to ensure the type material and dimensions of the clamp are adequate for the user's expected fabric strength.

D 4595

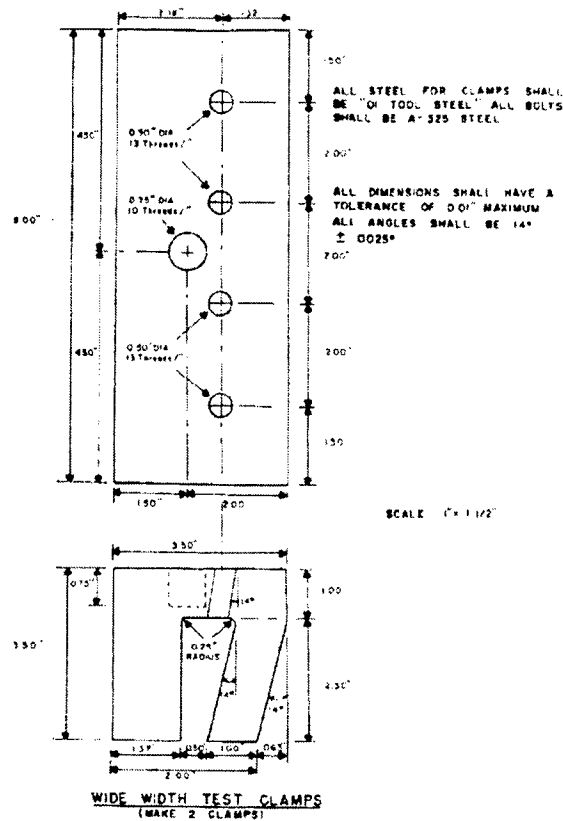

FIG. 1 Wide Width Test Clamps

6.2.2 *Size of Jaw Faces*—Each clamp shall have jaw faces measuring wider than the width of the specimen, 200 mm (8 in.), and a minimum of 50-mm (2-in.) length in the direction of the applied force.

6.3 *Area-Measuring Device*—Use an integrating accessory to the tensile testing machine or a planimeter.

6.4 *Distilled Water and Nonionic Wetting Agent*, for wet specimens only.

7. Sampling

7.1 *Lot Sample*—For the lot sample, take rolls of geotextiles as directed in an applicable material specification, or as agreed upon between the purchaser and the supplier.

NOTE 1—The extent of the sampling for wide-width strip tensile properties is generally defined in an applicable order or contract. Among the options available to the purchaser and the supplier is for the purchaser to accept certification by the manufacturer that the material in question meets the requirements agreed upon by the two parties, and what the basis for the certification is, such as, historical data generated from material manufactured under the same conditions.

7.2 *Laboratory Sample*—For the laboratory sample, take a full-width swatch approximately 1 m (40 in.) long in the machine direction from each roll in the lot sample. The

sample may be taken from the end portion of a roll provided there is no evidence it is distorted or different from other portions of the roll. In cases of dispute, take a sample that will exclude fabric from the outer wrap of the roll or the inner wrap around the core.

7.3 *Test Specimens*—For tests in the machine direction and the cross-machine direction, respectively, take from each swatch in the laboratory sample the number of specimens directed in Section 8. Take specimens at random from the laboratory sample, with those for the measurement of the machine direction tensile properties from different positions across the geotextile width, and the specimens for the measurement of the cross-machine direction tensile properties from different positions along the length of the geotextile. Take no specimens nearer the selvage or edge of the geotextile than 1/10 the width of the geotextile (see 8.2).

8. Test Specimen Preparation

8.1 *Number of Specimens*

8.1.1 Unless otherwise agreed upon, as when specified in an applicable material specification, take a number of specimens per fabric swatch such that the user may expect at

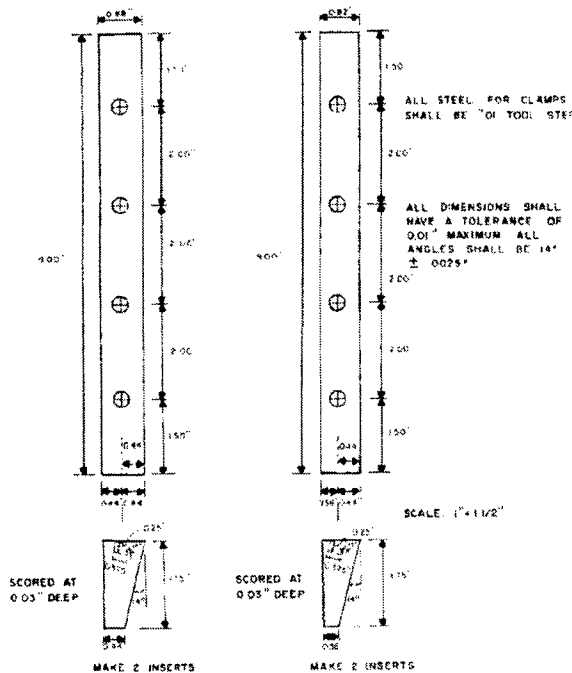

FIG. 2 Inserts for Wide Width Clamps

the 95 % probability level that the test result is not more than 5.0 % of the average above or below the true average of the swatch for each, the machine and cross-machine direction, respectively. Determine the number of specimens as follows:

8.1.1.1 *Reliable Estimate of v* —When there is a reliable estimate of v based upon extensive past records for similar materials tested in the user's laboratory as directed in the method, calculate the required number of specimens using Eq 1, as follows:

$$n = (tv/A)^2 \quad (1)$$

where:

n = number of specimens (rounded upward to a whole number).

v = reliable estimate of the coefficient of variation of individual observations on similar materials in the user's laboratory under conditions of single-operator precision, %.

t = the value of Student's t for one-sided limits (see Table 1), a 95 % probability level, and the degrees of freedom associated with the estimate of v , and

A = 5.0 % of the average, the value of the allowable variation.

8.1.1.2 *No Reliable Estimate of v* —When there is no reliable estimate of v for the user's laboratory, Eq 1 should

not be used directly. Instead, specify the fixed number of six specimens for each the machine direction and the cross-machine direction tests. The number of specimens is calculated using $v = 7.4$ % of the average. This value for v is somewhat larger than usually found in practice. When a reliable estimate of v for the user's laboratory becomes available, Eq 1 will usually require fewer than the fixed number of specimens.

8.2 *Test Specimen Size:*

8.2.1 Prepare each finished specimen 200-mm (8.0-in.) wide (excluding fringe when applicable, see 8.2.2) by at least 200-mm (8.0-in.) long (see 8.2.2) with the length dimension being designated and accurately parallel to the direction for which the tensile strength is being measured. Centrally, draw two lines running the full width of the specimen, accurately perpendicular to the length dimension and separated by 100 mm (4 in.) to designate the gage area (See Note 6).

8.2.2 For some woven geotextiles, it may be necessary to cut each specimen 210-mm (8.5-in.) wide and then remove an equal number of yarns from each side to obtain the 200 mm (8.0 in.) finished dimension. This helps maintain specimen integrity during the test.

8.2.3 The length of the specimen depends upon the type of clamps being used. It must be long enough to extend through the full length of both clamps, as determined for the direction of test.

D 4595

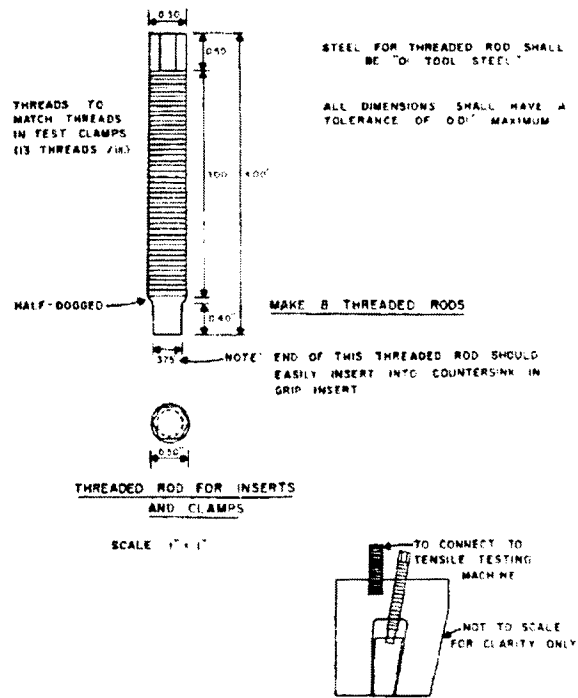

FIG. 3 End View of Composite of Clamp, Insert, and Threaded Rod

8.2.4 When specimen integrity is not affected, the specimens may be initially cut to the finished width.

8.2.5 When the wet tensile strength of the fabric is required in addition to the dry tensile strength, cut each test specimen at least twice as long as is required for a standard test (see Note 1). Number each specimen and then cut it crosswise into two parts, one for determining the conditioned tensile strength and the other for determining the wet tensile strength; each portion shall bear the specimen number. In this manner, each paired break is performed on test specimens containing the same yarns.

NOTE 2—For geotextiles which shrink excessively when wet, cut the test specimens for obtaining wet tensile strength longer in dimension than that for dry tensile strength

9. Conditioning

9.1 Bring the specimens to moisture equilibrium in the atmosphere for testing geotextiles. Equilibrium is considered to have been reached when the increase in mass of the specimen in successive weighings made at intervals of not less than 2 h does not exceed 0.1% of the mass of the specimen. In general practice, the industry approaches equilibrium from the "as received" side.

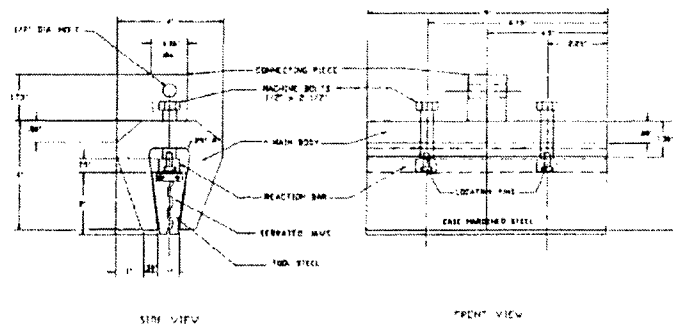

FIG. 4 Sanders Clamp

TABLE 1 Values of Student's *t* for One-Sided Limits and the 95 % Probability^A

df	One-Sided	df	One-Sided	df	One-Sided
1	6.314	11	1.796	22	1.717
2	2.920	12	1.782	24	1.711
3	2.353	13	1.771	26	1.706
4	2.132	14	1.761	28	1.701
5	2.015	15	1.753	30	1.697
6	1.943	16	1.746	40	1.684
7	1.895	17	1.740	50	1.676
8	1.860	18	1.734	60	1.671
9	1.833	19	1.729	120	1.658
10	1.812	20	1.725	∞	1.645

^A Values in this table were calculated using Hewlett Packard HP 67/97 Users' Library Programs 03848D, "One-Sided and Two-Sided Critical Values of Student's *t*" and 00350D, "Improved Normal and Inverse Distribution." For values at other than the 95 % probability level, see published tables of critical values of Student's *t* in any standard statistical text. Further use of this table is defined in Practice D 2905.

NOTE 3—It is recognized that in practice, geotextile materials are frequently not weighed to determine when moisture equilibrium has been reached. While such a procedure cannot be accepted in cases of dispute, it may be sufficient in routine testing to expose the material to the standard atmosphere for testing for a reasonable period of time before the specimens are tested. A time of at least 24 h has been found acceptable in most cases. However, certain fibers may exhibit slow moisture equalization rates from the "as received" wet side. When this is known, a preconditioning cycle, as described in Practice D 1776, may be agreed upon between contractual parties.

9.2 Specimens to be tested in the wet condition shall be immersed in water, maintained at a temperature of $21 \pm 2^\circ\text{C}$ ($70 \pm 4^\circ\text{F}$). The time of immersion must be sufficient to wet-out the specimens thoroughly, as indicated by no significant change in strength or elongation following a longer period of immersion, and at least 2 min. To obtain thorough wetting, it may be necessary or advisable to add not more than 0.05 % of a nonionic neutral wetting agent to the water.

10. Procedure

10.1 *Conditioned Specimens*—Test adequately conditioned specimens in the atmosphere for testing geotextiles.

10.2 *Wet Specimens*—Test thoroughly wet specimens in the normal machine set-up within 20 min after removal from the water.

10.3 *Machine Set-Up Conditions*—Adjust the distance between the clamps at the start of the test at 100 ± 3 mm (4 ± 0.1 in.). At least one clamp should be supported by a free swivel or universal joint which will allow the clamp to rotate in the plane of the fabric. Select the force range of the testing machine so the break occurs between 10 and 90 % of full-scale force. Set the machine to a strain rate of 10 ± 3 %/min.

NOTE 4—It is recognized that some tensile tests on geotextiles are conducted using a manually applied strain rate. In that case, approximately a 2 %/min strain rate should be used. In any event, the strain rate described in 10.3 is preferred.

10.4 *Insertion of Specimen in Clamps*—Mount the specimen centrally in the clamps. Do this by having the two lines, which were previously drawn 100 ± 3 mm (4.0 ± 0.1 in.) apart across the width of the specimen positioned adjacent to the inside edges of the upper and lower jaw. The specimen length in the machine direction and cross-machine direction tests, respectively, must be parallel to the direction of application of force.

10.5 *Measurement of Tensile Strength*—Start the tensile testing machine and the area measuring device, if used, and continue running the test to rupture. Stop the machine and reset to the initial gage position. Record and report the test results to three significant figures for each direction separately (See Note 6).

10.5.1 If a specimen slips in the jaws, breaks at the edge of or in the jaws, or if for any reason attributed to faulty operation the result falls markedly below the average for the set of specimens, discard the result and test another specimen. Continue until the required number of acceptable breaks have been obtained.

10.5.2 The decision to discard the results of a break shall be based on observation of the specimen during the test and upon the inherent variability of the fabric. In the absence of other criteria for rejecting a so-called jaw break, any break occurring within 5 mm ($1/4$ in.) of the jaws which results in a value below 20 % of the average of all the other breaks shall be discarded. No other break shall be discarded unless the test is known to be faulty.

10.5.3 It is difficult to determine the precise reason why certain specimens break near the edge of the jaws. If a jaw break is caused by damage to the specimen by the jaws, then the results should be discarded. If, however, it is merely due to randomly distributed weak places, it is a perfectly legitimate result. In some cases, it may also be caused by a concentration of stress in the area adjacent to the jaws because they prevent the specimen from contracting in width as the force is applied. In these cases, a break near the edge of the jaws is inevitable and shall be accepted as a characteristic of the particular method of test.

10.5.4 For instructions regarding the preparation of specimens made from glass fiber to minimize damage in the jaws, see Specification D 579.

10.5.5 If a geotextile manifests any slippage in the jaws or if more than 24 % of the specimens break at a point within 5 mm (0.25 in.) of the edge of the jaw, then (1) the jaws may be padded, (2) the geotextile may be coated under the jaw face area, or (3) the surface of the jaw face may be modified. If any of the modifications listed above are used, state the method of modification in the report.

10.6 *Measurement of Elongation*—Measure the elongation of the geotextile at any stated force by means of a suitable recording device at the same time as the tensile strength is determined, unless otherwise agreed upon, as provided for in an applicable material specification. Measure the elongation to three significant figures as shown in Fig. X1.1.

10.6.1 A measured strain within the specimen can be obtained from jaw to jaw measurements by gaging along the center axis between the jaws across the center 3 in. of the specimen. These measurements can be made using a sealed rule taped on a line on the upper end of the specimen, in the gage area, and recording the change in length as measured from a line spaced 3 in. below the upper line. In addition, the center portion of the specimen can be gaged using LVDTs or mechanical gages. By comparing, it can be determined if slippage is occurring in the clamps.

11. Calculations

11.1 *Tensile Strength*—Calculate the tensile strength of

individual specimens; that is, the maximum force per unit width to cause a specimen to rupture as read directly from the testing instrument expressed in N/m (lbf/in.) of width, using Eq 2 (See Fig. X1.1), as follows:

$$\sigma_f = F_f/W_s \quad (2)$$

where:

- σ_f = tensile strength, N/m (lbf/in.) of width,
- F_f = observed breaking force, N (lbf), and
- W_s = specified specimen width, m (in.).

11.2 *Elongation*—Calculate the elongation of individual specimens, expressed as the percentage increase in length, based upon the initial nominal gage length of the specimen using Eq 3 for XY type recorders, or Eq 4 for manual readings (ruler), as follows:

$$\epsilon_p = (E \times R \times 100)/(C \times L_g) \quad (3)$$

$$\epsilon_p = (\Delta L \times 100)/L_p \quad (4)$$

where:

- ϵ_p = elongation, %,
- E = distance along the zero force axis from the point the curve leaves the zero force axis to a point of corresponding force, mm (in.),
- R = testing speed rate, m/min (in./min),
- C = recording chart speed, m/min (in./min),
- L_g = initial nominal gage length, mm (in.), and
- ΔL = the unit change in length from a zero force to the corresponding measured force, mm (in.).

NOTE 5—Some clamping arrangements may lead to slack in the specimen within the gage area. When this occurs, that increase of the specimen length must be added and included as part of L_p nominal gage length.

11.3 *Tensile Modulus*:

11.3.1 *Initial Tensile Modulus*—Determine the location and draw a line tangent to the first straight portion of the force – elongation curve. At any point on this tangent line, measure the force and the corresponding elongation with respect to the zero force axis. Calculate initial tensile modulus in N/m (lbf/in.) of width using Eq 5. (See Fig. X1.1), as follows:

$$J_i = (F \times 100)/(\epsilon_p \times W_s) \quad (5)$$

where:

- J_i = initial tensile modulus, N/m (lbf/in.) of width,
- F = determined force on the drawn tangent line, N (lbf),
- ϵ_p = corresponding elongation with respect to the drawn tangent line and determined force, %, and
- W_s = specimen width, m (in.).

11.3.2 *Offset Tensile Modulus*—Determine the location and draw a line tangent to the force—elongation curve between the tangent point and the proportional limit and through the zero force axis. Measure the force and the corresponding elongation with respect to the force axis. Calculate offset tensile modulus using Eq 6 (See Figs. X1.1 and X2.1), as follows:

$$J_o = (F \times 100)/(\epsilon_p \times W_s) \quad (6)$$

where:

- J_o = offset tensile modulus, N/m (lbf/in.) of width,
- F = determined force on the drawn tangent line, N (lbf),
- ϵ_p = corresponding elongation with respect to the drawn tangent line and determined force, %, and

W_s = specimen width, m (in.).

11.3.3 *Secant Tensile Modulus*—Determine the force for a specified elongation, ϵ_2 , usually 10 %, and label that point on the force – elongation curve as P_2 . Likewise, label a second point, P_1 at a specified elongation, ϵ_1 , usually 0 % elongation. Draw a straight line (secant) through both points P_1 and P_2 intersecting the zero force axis. The preferred values are 0 and 10 % elongation, respectively, although other values may be used, for example, when provided for in an applicable material specification. Calculate secant tensile modulus using Eq 7 (See Fig. X3.1), as follows:

$$J_s = (F \times 100)/(\epsilon_p \times W_s) \quad (7)$$

where:

- J_s = secant tensile modulus, N (lbf) between specified elongations per m (in.) of width,
- F = determined force on the constructed line, N (lbf),
- ϵ_p = corresponding elongation with respect to the constructed line and determined force, %, and
- W_s = specimen width, m (in.).

11.4 *Breaking Toughness*:

11.4.1 When using the force – elongation curves, draw a line from the point of maximum force of each specimen perpendicular to the elongation axis. Measure the area bounded by the curve, the perpendicular and the elongation axis by means of an integrator or a planimeter, or cut out the area of the chart under the force – elongation curve, weigh it, and calculate the area under the curve using the weight of the unit area.

11.4.2 When determining breaking toughness of geotextiles using a manual gage (steel rule or dial) to measure the amount of strain at a given force, record the change in specimen length for at least ten corresponding force intervals. Approximately equal force increments should be used throughout the application of force having the final measurement taken at specimen rupture.

11.4.3 When determining the breaking toughness of geotextiles that exhibit take up of slack caused by fabric weave, crimp, or design, the area under the force – elongation curve which precedes the initial modulus line represents the work to remove this slack. Automatic-area-measuring equipment may or may not include this area in measuring breaking toughness, and therefore, such information should be reported along with the value observed for the breaking toughness.

11.4.4 Calculate the breaking toughness or work-to-break per unit surface area for each specimen when using XY recorders using Eq 8, or when using automatic area measuring equipment using Eq 9, or when using manually obtained strain measurements with a steel rule or dial gage using Eq 10.

$$T_u = (A \times S \times R)/(W_s \times C \times A_s) \quad (8)$$

$$T_u = (I \times S \times R)/(A_s \times A_s) \quad (9)$$

$$T_u = \sum_{i=1}^n p_i \Delta l_i \quad (10)$$

where:

- T_u = breaking toughness, J/m² (in. · lbf/in.²),
- A_s = area under the force – elongation curve, m² (in.²),
- S = full scale force range, N (lbf),
- R = testing speed rate, m/min. (in./min.),

- W_c = recording chart width, m (in.).
- C = recording chart speed, m/min. (in./min.).
- A_s = area of the test specimen within the gage length, m^2 (in.²), usually 0.200 m by 0.100 m (8 in. by 4 in.) (See Note 6).
- V = integrator reading.
- I_c = integrator constant.
- F_j = observed breaking force, N (lbf).
- ΔL = unit change in length from a zero force to the corresponding measured force, mm (in.).
- p = unit stress per area of test specimen within the gage length, N/m^2 (lbf/in.²), and
- 0 = zero force.

11.5 *Average Values*—Calculate the average values for tensile strength, elongation, initial modulus, secant modulus, and breaking toughness of the observations for the individual specimens tested to three significant figures.

12. Report

12.1 Report that the specimens were tested as directed in Test Method D 4595. Describe the material or product sampled and the method of sampling used.

12.2 Report all of the following applicable items for both the machine direction and cross direction of the material tested.

12.2.1 Average breaking force/unit width in N/m (lbf/in.) as tensile strength.

12.2.2 Average elongation at specified force in percent.

12.2.3 If requested, the average initial or secant modulus in N/m (lbf/in.). For secant modulus, state that portion of the force – elongation curve used to determine the modulus, that is, 0 to 10 % elongation, reported as 10 % secant modulus. Other portions of the force – elongation curve can be reported as requested.

12.2.4 If requested, the average breaking toughness (work-to-break per unit surface area) in J/m^2 (in·lbf/in.²). Report the method of calculation.

12.2.5 If requested, the standard deviation, coefficient of variation, or both, of any of the properties.

12.2.6 If requested, include a force – elongation curve as part of the report.

12.2.7 Condition of specimen (dry or wet).

12.2.8 Number of specimens tested in each direction.

12.2.9 Make and model of testing machine.

12.2.10 Size of jaw faces used.

12.2.11 Type of padding used in jaws, modification of specimens gripped in the jaws, or modification of jaw faces, if used.

12.2.12 Full scale force range used for testing.

12.2.13 Any modification of procedure (see 5.2).

13. Precision and Bias (Note 6)⁴

13.1 *Precision*—The precision of this test method of testing wide width strip tensile properties is being established.

13.2 *Bias*—The true value of wide width strip tensile properties of geotextiles can only be defined in terms of a specific test method. Within this limitation, the procedures in Test Method D 4595 has no known bias.

NOTE 6—The wide width tensile task group of subcommittee D 35.01 conducted a pilot interlaboratory test in 1985. This test indicated that additional clarification to illustrate implied procedures within the test procedure should be provided. The major problem encountered was definition of the origin (zero position) point on the force – elongation curve. The following procedural interpretations with respect to this method are suggested: (1) No bonding of the specimen should be provided within the clamp face area for materials showing a breaking force of 17500 N/m (100 lbf/in.) and under, unless shown to be necessary as agreed upon between the purchaser and supplier. (2) Protection within the clamp faces should be provided, such as resin bonded tabs, for materials having a breaking force in excess of 17500 N/m (100 lbf/in.). (3) A pretension force should be provided having a minimum total applied force to the specimen of 44.5 N (10 lbf) for materials exhibiting an ultimate breaking force of 17500 N/m (100 lbf/in.) and under. For materials exhibiting a breaking force in excess of 17500 N/m (100 lbf/in.), a pretension force equal to 1.25 % of the expected breaking force should be applied, however in no case should the total pretension force exceed 222 N (50 lbf). A low force range may be used to establish the point of the applied pretension force on the force – elongation curve and then increased to the working force range selected for the material under test. (4) The gage length should be determined relative to the zero base line on the extension axis and the applied pretension force (zero position point). (5) The zero position point should be used to determine the elongation, initial modulus, and secant modulus when applicable. (6) Roller clamps and other mechanical clamping mechanisms have been successfully used in conjunction with external extensometers, however strain rates may be different compared to flat-faced clamps. (7) Extreme care should be used when loading specimens in the clamps to insure vertical alignment of the specimen in the direction of test. The task group is continuing further interlaboratory testing. It is the intent of the task group to include the above mentioned clarifications and subsequent changes as a result of improved technology in future issues of this test method.

⁴ Supporting data are available from ASTM Headquarters. Request RR: D-35-1002.

APPENDIX

(Nonmandatory Information)

X1. INITIAL GEOTEXTILE TENSILE MODULUS

X1.1 In a typical force – elongation curve (Fig. X1.1), there is usually a toe region *AC* that represents take up of slack, alignment, or seating of the specimen; it can also represent a significant part of the elongation characteristic of the specimen. This region is considered when determining

the initial geotextile modulus.

X1.1.1 The initial geotextile tensile modulus can be determined by dividing the force at any point along the line *AG* (or its extension) by the elongation at the same point (measured from point *A*, defined as zero strain).

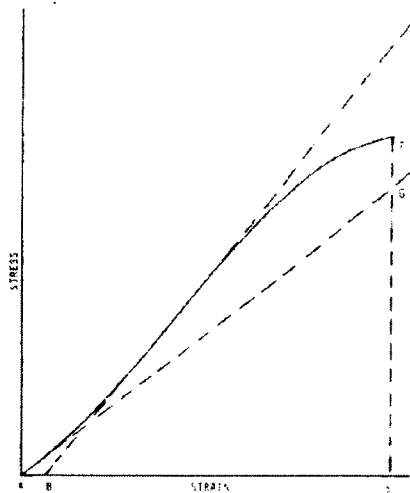

FIG. X1.1 Material with Hookean Region

X2. OFFSET GEOTEXTILE TENSILE MODULUS

X2.1 In the case of a geotextile exhibiting a region of Hookean (linear) behavior (Fig. X1.1), a continuation of the linear region of the curve is constructed through the zero-force axis. This intersection, point *B*, is the zero elongation point from which elongation is measured.

X2.1.1 The offset geotextile tensile modulus can be determined by dividing the force at any point along the line *CD* (or its extension) by the elongation at the same point (measured from point *B*, defined as zero strain). The point where line *CD* first touches the force – elongation curve is the tangent point.

X2.2 In the case of a geotextile that does not exhibit any linear region (Fig. X2.1), a tangent is constructed to the maximum slope at the tangent point *H'*. This is extended to intersect the zero elongation axis at point *B'*. This intersection point *B'* is the zero elongation point from which elongation is measured.

X2.2.1 The offset geotextile tensile modulus can be determined by dividing the force at any point along line *H'K'* (or its extension) by the elongation at the same point (measured from: point *B'*, defined as zero strain).

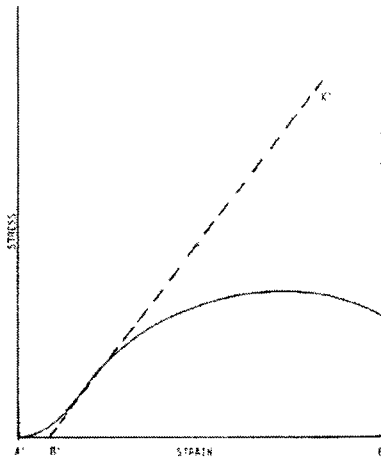

FIG. X2.1 Material with No Hookean Region

X3. SECANT GEOTEXTILE TENSILE MODULUS

X3.1 In a typical force - elongation curve (Fig. X3.1), a straight line is constructed through the zero force axis, usually at zero strain point A'' and a second point usually at 10 % strain, point M'' . The intersection point A' is the zero elongation point from which elongation is measured.

X3.1.1 The secant geotextile modulus can be determined by dividing the force at any point along line $A''M''$ (or its extension) by the elongation at the same point (measured from point A' , defined as zero strain).

X3.1.2 Figure X3.1 also represents a straight line constructed through any two specified points, point G'' and point R'' , other than zero and 10 % strain. In this case, the line extends through the zero force axis at point B'' . This intersection is the zero elongation point from which elongation is measured. The secant geotextile tensile modulus can be determined by dividing the force at any point along line $Q''R''$ (or its extension) by the elongation at the same point (measured from point B'' , defined as zero strain).

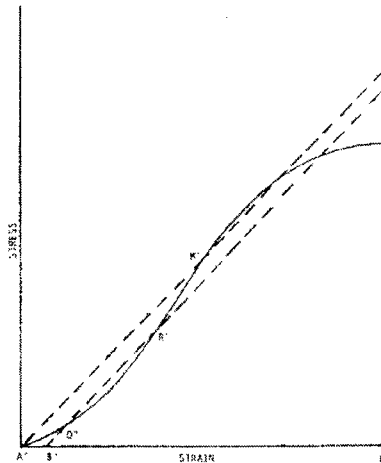

FIG. X3.1 Construction Line for Secant Modulus

 D 4595

The American Society for Testing and Materials takes no position respecting the validity of any patent rights asserted in connection with any item mentioned in this standard. Users of this standard are expressly advised that determination of the validity of any such patent rights, and the risk of infringement of such rights, are entirely their own responsibility.

This standard is subject to revision at any time by the responsible technical committee and must be reviewed every five years and if not revised, either reapproved or withdrawn. Your comments are invited either for revision of this standard or for additional standards and should be addressed to ASTM Headquarters. Your comments will receive careful consideration at a meeting of the responsible technical committee, which you may attend. If you feel that your comments have not received a fair hearing you should make your views known to the ASTM Committee on Standards, 1916 Race St., Philadelphia, PA 19103.

US Army Engineer Waterways Exp. Station
 Geotechnical Laboratory
 Airfields and Pavements Division

Geotextile Tensile Test - ASTM D 4595
 Secant Modulus at 5% and 10% Elongation
 T.C. - 12/97

Test type: Tensile
 Operator name: T. Carr
 Sample Identification: HS600M
 Interface Type: 4200 Series
 Machine Parameters of test:
 Sample Rate (pts/sec): 2.000
 Crosshead Speed (in/min): .4000

Instron Corporation
 Series IX Automated Materials Testing System 6.02
 Test Date: 14 Jan 1998
 Sample Type: FAB.
 Humidity (%): 50
 Temperature (deg. F): 73

Dimensions:

	Spec. 1	Spec. 2	Spec. 3	Spec. 4	Spec. 5	Spec. 6
Width (in)	8.0000	8.0000	8.0000	8.0000	8.0000	8.0000
Thickness (in)	.10000	.10000	.10000	.10000	.10000	.10000
Spec gauge len (in)	4.0000	4.0000	4.0000	4.0000	4.0000	4.0000
Grip distance (in)	4.0000	4.0000	4.0000	4.0000	4.0000	4.0000

Out of 6 specimens, 0 excluded.

Sample comments:

Specimen Number	Specimen #	Load at Max.Load (lbs)	Tensile Strength at Max.Load (lbs/in)	Displcment at Max.Load (in)	Elongation at Max.Load (%)	Tensile Str. @ 5% Elongation (lbs/in)	Tensile Str. @ 10% Elongation (lbs/in)	Secant Mod @ 5% Elongation (lbs/in)	Secant Mod @ 10% Elongation (lbs/in)
1	2M	4595.	574.4	.8208	20.520	155.3	283.1	3107.	2831.
2	3M	4223.	527.9	.4828	12.070	229.6	447.8	4591.	4478.
3	11M	4518.	564.7	.6513	16.280	117.3	309.1	2347.	3091.
4	12M	2289.	286.1	.3381	8.454	179.7	233.8	3594.	2338.
5	28M	4784.	598.0	.5927	14.820	135.9	364.4	2717.	3644.
6	31M	4301.	537.6	.5016	12.540	234.5	448.0	4689.	4480.
Mean:		4118.	514.8	.5646	14.110	175.4	347.7	3508.	3477.
Standard Deviation:		919.	114.9	.1648	4.121	48.5	88.3	971.	883.
CofGVar:		22.31	22.31	29.20	29.20	27.67	25.39	27.67	25.39

Table C.1 ASTM 4595 Group A GT 600 Machine Direction.

US Army Engineer Waterways Exp. Station
 Geotechnical Laboratory
 Airfields and Pavements Division

Geotextile Tensile Test - ASTM D 4595
 Secant Modulus at 5% and 10% Elongation
 T.C. - 12/97

Test type: Tensile
 Operator name: T. Carr
 Sample Identification: HS600xm
 Interface Type: 4200 Series
 Machine Parameters of test:
 Sample Rate (pts/sec): 2.000
 Crosshead Speed (in/min): .4000

Instron Corporation
 Series IX Automated Materials Testing System 6.02
 Test Date: 13 Jan 1998
 Sample Type: FAB.
 Humidity (%): 50
 Temperature (deg. F): 73

Dimensions:

	Spec. 1	Spec. 2	Spec. 3	Spec. 4	Spec. 5	Spec. 6
Width (in)	8.0000	8.0000	8.0000	8.0000	8.0000	8.0000
Thickness (in)	.10000	.10000	.10000	.10000	.10000	.10000
Spec gauge len (in)	4.0000	4.0000	4.0000	4.0000	4.0000	4.0000
Grip distance: (in)	4.0000	4.0000	4.0000	4.0000	4.0000	4.0000

Out of 6 specimens, 0 excluded.

Sample comments:

Specimen Number	Specimen #	Load at Max. Load (lbs)	Tensile Strength ● Max. Load (lbs/in)	Displcmnt at Max. Load (in)	Elongation at Max. Load (%)	Tensile Str. ● 5% Elongation (lbs/in)	Tensile Str. ● 10% Elongation (lbs/in)	Secant Mod ● 5% Elongation (lbs/in)	Secant Mod ● 10% Elongation (lbs/in)
1	9XM	3360.	420.0	.4281	10.700	211.1	412.9	4222.	4129.
2	15XM	2411.	301.4	.4952	12.380	119.8	263.2	2395.	2632.
3	24XM	2878.	359.7	.4370	10.930	177.9	332.7	3557.	3327.
4	27XM	2967.	370.9	.3484	8.710	216.8	347.6	4336.	3476.
5	26XM	3716.	464.5	.4655	11.640	209.6	409.3	4193.	4093.
6	34XM	3819.	477.4	.5427	13.570	154.3	349.7	3085.	3497.
Mean:		3192.	399.0	.4528	11.320	181.6	352.6	3631.	3526.
Standard Deviation:		540.	67.4	.0660	1.651	38.7	55.3	774.	553.
CoFoFVar:		16.90	16.90	14.58	14.58	21.30	15.68	21.30	15.68

Table C.2 ASTM 4595 Group A GT 600 Cross Direction.

US Army Engineer Waterways Exp. Station
Geotechnical Laboratory
Airfields and Pavements Division

Geotextile Tensile Test - ASTM D 4595
Secant Modulus at 5% and 10% Elongation
T.C. - 12/97

Test type:	Tensile	Instron Corporation
Operator name:	GOODIN	Series IX Automated Materials Testing System 6.02
		Test Date: 15 Jan 1998
Sample Identification:	HS800M	Sample Type: FAB.
Interface Type:	4200 Series	
Machine Parameters of test:		
Sample Rate (pts/sec):	2.000	Humidity (%): 50
Crosshead Speed (in/min):	.4000	Temperature (deg. F): 73

Dimensions:

	Spec. 1	Spec. 2	Spec. 3	Spec. 4	Spec. 5	Spec. 6
Width (in)	8.0000	8.0000	8.0000	8.0000	8.0000	8.0000
Thickness (in)	.10000	.10000	.10000	.10000	.10000	.10000
Spec gauge len (in)	4.0000	4.0000	4.0000	4.0000	4.0000	4.0000
Grip distance (in)	4.0000	4.0000	4.0000	4.0000	4.0000	4.0000

Out of 6 specimens, 0 excluded.

Sample comments:

Specimen Number	Specimen #	Load at Max.Load (lbs)	Tensile Strength @ Max.Load (lbs/in)	Displcment at Max.Load (in)	Elongation at Max.Load (%)	Tensile Str. @ 5% Elongation (lbs/in)	Tensile Str. @ 10% Elongation (lbs/in)	Secant Mod @ 5% Elongation (lbs/in)	Secant Mod @ 10% Elongation (lbs/in)
1	3M	4088.	511.0	.8503	21.26	256.5	444.2	5130.	4442.
2	3M	6211.	776.4	.7144	17.86	254.3	493.3	5086.	4933.
3	17M	7129.	891.1	.7186	17.97	295.8	559.3	5915.	5593.
4	19M	5354.	669.2	.5287	13.22	289.4	540.4	5788.	5404.
5	24M	7235.	904.4	.7415	18.54	285.3	528.8	5705.	5288.
6	34M	6475.	809.4	.6971	17.43	286.6	539.4	5732.	5394.
Mean:		6082.	760.2	.7084	17.71	278.0	517.6	5559.	5176.
Standard Deviation:		1192.	149.0	.1037	2.59	17.9	42.0	357.	420.
CoefVar:		19.60	19.60	14.64	14.64	6.43	8.12	6.43	8.12

Table C.3 ASTM 4595 Group A GT 800 Machine Direction.

US Army Engineer Waterways Exp. Station
Geotechnical Laboratory
Airfields and Pavements Division

Geotextile Tensile Test - ASTM D 4595
Secant Modulus at 5% and 10% Elongation
T.C. - 12/97

Test type:	Tensile	Instron Corporation
Operator name:	GOODIN	Series IX Automated Materials Testing System 6.02
		Test Date: 14 Jan 1998
Sample Identification:	HSS00XM	Sample Type: FAB.
Interface Type:	4200 Series	
Machine Parameters of test:		
Sample Rate (pts/sec):	2.000	Humidity (%): 50
Crosshead Speed (in/min):	.4000	Temperature (deg. F): 73

Dimensions:

	Spec. 1	Spec. 2	Spec. 3	Spec. 4	Spec. 5	Spec. 6
Width (in)	8.0000	8.0000	8.0000	8.0000	8.0000	8.0000
Thickness (in)	.10000	.10000	.10000	.10000	.10000	.10000
Spec gauge len (in)	4.0000	4.0000	4.0000	4.0000	4.0000	4.0000
Grip distance: (in)	4.0000	4.0000	4.0000	4.0000	4.0000	4.0000

Out of 6 specimens, 0 excluded.

Sample comments:

Specimen Number	Specimen #	Load at Max. Load (lbs)	Tensile Strength ● (lbs/in)	Displcmnt at Max. Load (in)	Elongation at Max. Load (%)	Tensile Str. ● 5% (lbs/in)	Tensile Str. ● 10% (lbs/in)	Secant Mod ● 5% (lbs/in)	Secant Mod ● 10% (lbs/in)
1	2XM	4371.	546.4	.5734	14.330	178.3	380.8	3565.	3808.
2	5XM	3656.	457.0	.4300	10.750	227.8	431.7	4556.	4317.
3	9XM	4473.	559.1	.5355	13.390	223.1	433.8	4461.	4338.
4	22XM	4834.	604.2	.6290	15.720	173.2	383.4	3463.	3834.
5	14XM	3347.	418.4	.3985	9.962	223.2	400.4	4465.	4004.
6	26XM	4202.	525.2	.4784	11.960	232.4	450.0	4647.	4500.
Mean:		4147.	518.4	.5075	12.690	209.6	413.3	4193.	4133.
Standard Deviation:		550.	68.8	.0879	2.197	26.5	29.1	531.	291.
CofOfVar:		13.26	13.26	17.32	17.32	12.67	7.03	12.67	7.03

Table C.4 ASTM 4595 Group A GT 800 Cross Direction.

US Army Engineer Waterways Exp. Station
Geotechnical Laboratory
Airfields and Pavements Division

Geotextile Tensile Test - ASTM D 4595
Secant Modulus at 5% and 10% Elongation
T.C. - 12/97

Test type:	Tensile	Instron Corporation
Operator name:	GOODIN	Series IX Automated Materials Testing System 6.02
		Test Date: 16 Jan 1998
Sample Identification:	HS1715M	Sample Type: FAB.
Interface Type:	4200 Series	
Machine Parameters of test:		
Sample Rate (pts/sec):	2.000	Humidity (%): 50
Crosshead Speed (in/min):	.4000	Temperature (deg. F): 73

Dimensions:	Spec. 1	Spec. 2	Spec. 3	Spec. 4	Spec. 5	Spec. 6
Width (in)	8.0000	8.0000	8.0000	8.0000	8.0000	8.0000
Thickness (in)	.10000	.10000	.10000	.10000	.10000	.10000
Spec gauge len (in)	4.0000	4.0000	4.0000	4.0000	4.0000	4.0000
Grip distance (in)	4.0000	4.0000	4.0000	4.0000	4.0000	4.0000

Out of 6 specimens, 0 excluded.

Sample comments:

Specimen Number	Specimen #	Load at Max. Load (lbs)	Tensile Strength @ Max. Load (lbs/in)	Displcment at Max. Load (in)	Elongation at Max. Load (%)	Tensile Str. @ 5% Elongation (lbs/in)	Tensile Str. @ 10% Elongation (lbs/in)	Secant Mod @ 5% Elongation (lbs/in)	Secant Mod @ 10% Elongation (lbs/in)
1	8M	8659.	1082.0	.7492	18.73	418.4	678.5	8368.	6785.
2	14M	8298.	1037.0	.5523	13.81	500.5	832.8	10010.	8328.
3	21M	6916.	864.5	.4896	12.24	449.4	746.8	8989.	7468.
4	22M	9429.	1179.0	.7168	17.92	414.6	741.7	8292.	7417.
5	23M	7019.	877.4	.5279	13.20	365.2	689.6	7303.	6896.
6	30M	7445.	930.6	.5766	14.42	412.8	715.5	8256.	7155.
Mean:		7961.	995.1	.6021	15.05	426.8	734.1	8536.	7341.
Standard Deviation:		1000.	125.0	.1059	2.65	45.1	55.5	902.	555.
CofofVar:		12.56	12.56	17.59	17.59	10.56	7.56	10.56	7.56

Table C.5 ASTM 4595 Group A GT 1715 Machine Direction.

US Army Engineer Waterways Exp. Station
 Geotechnical Laboratory
 Airfields and Pavements Division

Geotextile Tensile Test - ASTM D 4595
 Secant Modulus at 5% and 10% Elongation
 T.C. - 12/97

Test type: Tensile
 Operator name: GOODIN
 Sample Identification: HSI715XM
 Interface Type: 4200 Series
 Machine Parameters of test:
 Sample Rate (pts/sec): 2.000
 Crosshead Speed (in/min): .4000

Instron Corporation
 Series IX Automated Materials Testing System 6.02
 Test Date: 15 Jan 1998
 Sample Type: FAB.
 Humidity (%): 50
 Temperature (deg. F): 73

Dimensions:

	Spec. 1	Spec. 2	Spec. 3	Spec. 4	Spec. 5	Spec. 6
Width (in)	8.0000	8.0000	8.0000	8.0000	8.0000	8.0000
Thickness (in)	.10000	.10000	.10000	.10000	.10000	.10000
Spec gauge len (in)	4.0000	4.0000	4.0000	4.0000	4.0000	4.0000
Grip distance: (in)	4.0000	4.0000	4.0000	4.0000	4.0000	4.0000

Out of 6 specimens, 0 excluded.

Sample comments:

Specimen Number	Specimen #	Load at Max. Load (lbs)	Tensile Strength (lbs/in)	Displment at Max. Load (in)	Elongation at Max. Load (%)	Tensile Str. @ 5% Elongation (lbs/in)	Tensile Str. @ 10% Elongation (lbs/in)	Secant Mod @ 5% Elongation (lbs/in)	Secant Mod @ 10% Elongation (lbs/in)
1	2XM	3618.	452.2	.4324	10.81	222.8	425.7	4457.	4257.
2	4XM	4689.	586.1	.5370	13.43	234.3	462.2	4685.	4622.
3	5XM	3924.	490.5	.4448	11.12	225.2	445.3	4504.	4453.
4	7XM	5064.	633.0	.6346	15.87	244.4	417.8	4289.	4178.
5	17XM	4661.	582.6	.4901	12.25	248.6	488.5	4971.	4885.
6	27XM	4769.	596.1	.5025	12.56	247.0	484.9	4940.	4849.
Mean:		4454.	556.8	.5069	12.67	232.1	454.1	4641.	4541.
Standard Deviation:		557.	69.6	.0734	1.84	13.7	29.7	275.	297.
CofOfVar:		12.50	12.50	14.48	14.48	5.92	6.54	5.92	6.54

Table C.6 ASTM 4595 Group A GT 1715 Cross Direction.

US Army Engineer Waterways Exp. Station
Geotechnical Laboratory
Airfields and Pavements Division

Geotextile Tensile Test - ASTM D 4595
Secant Modulus at 5% and 10% Elongation
T.C. - 12/97

Test type:	Tensile	Instron Corporation
Operator name:	GOODIN	Series IX Automated Materials Testing System 6.02
		Test Date: 22 Jan 1998
Sample Identification:	MGD10M	Sample Type: FAB.
Interface Type:	4200 Series	
Machine Parameters of test:		
Sample Rate (pts/sec):	2.000	Humidity (%): 50
Crosshead Speed (in/min):	.4000	Temperature (deg. F): 73

Dimensions:

	Spec. 1	Spec. 2	Spec. 3	Spec. 4	Spec. 5	Spec. 6
Width (in)	8.0000	8.0000	8.0000	8.0000	8.0000	8.0000
Thickness (in)	.10000	.10000	.10000	.10000	.10000	.10000
Spec gauge len (in)	4.0000	4.0000	4.0000	4.0000	4.0000	4.0000
Grip distance: (in)	4.0000	4.0000	4.0000	4.0000	4.0000	4.0000

Out of 6 specimens, 0 excluded.

Sample comments:

Specimen Number	Specimen #	Load at Max.Load (lbs)	Tensile Strength * (lbs/in)	Displcment at Max.Load (in)	Elongation at Max.Load (%)	Tensile Str. * 5% Elongation (lbs/in)	Tensile Str. * 10% Elongation (lbs/in)	Secant Mod * 5% Elongation (lbs/in)	Secant Mod * 10% Elongation (lbs/in)
1	8M	2981.	372.6	.4571	11.43	198.7	351.2	3974.	3512.
2	11M	3326.	415.7	.5192	12.98	200.4	346.2	4008.	3482.
3	12M	3093.	386.6	.4425	11.06	223.9	369.4	4479.	3694.
4	21M	3384.	423.0	.4610	11.52	212.6	380.9	4251.	3809.
5	31M	3788.	473.5	.5406	13.52	219.0	374.4	4380.	3744.
6	34M	3341.	417.6	.5069	12.67	217.5	359.3	4351.	3593.
Mean:		3319.	414.9	.4879	12.20	212.0	363.9	4241.	3639.
Standard Deviation:		279.	34.9	.0396	.99	10.3	13.1	207.	131.
CofOfVar:		8.42	8.42	8.12	8.12	4.87	3.60	4.87	3.60

Table C.7 ASTM 4595 Group B GG 10 Machine Direction.

US Army Engineer Waterways Exp. Station
 Geotechnical Laboratory
 Airfields and Pavements Division

Geotextile Tensile Test - ASTM D 4595
 Secant Modulus at 5% and 10% Elongation
 T.C. - 12/97

Test type: Tensile Instron Corporation
 Operator name: GOODIN Series IX Automated Materials Testing System 6.02
 Test Date: 22 Jan 1998
 Sample Identification: MGD10XM Sample Type: FAB.
 Interface Type: 4200 Series
 Machine Parameters of test:
 Sample Rate (pts/sec): 2.000 Humidity (%): 50
 Crosshead Speed (in/min): .4000 Temperature (deg. F): 73

Dimensions:

	Spec. 1	Spec. 2	Spec. 3	Spec. 4	Spec. 5	Spec. 6
Width (in)	8.0000	8.0000	8.0000	8.0000	8.0000	8.0000
Thickness (in)	.10000	.10000	.10000	.10000	.10000	.10000
Spec gauge len (in)	4.0000	4.0000	4.0000	4.0000	4.0000	4.0000
Grip distance (in)	4.0000	4.0000	4.0000	4.0000	4.0000	4.0000

Out of 6 specimens, 0 excluded.

Sample comments:

Specimen Number	Specimen #	Load at Max.Load (lbs)	Tensile Strength ● (lbs/in)	Displcmnt at Max.Load (in)	Elongation at Max.Load (%)	Tensile Str. ● 5% (lbs/in)	Tensile Str. ● 10% (lbs/in)	Secant Mod ● 5% (lbs/in)	Secant Mod ● 10% (lbs/in)
1	4XM	931.0	116.40	.3808	9.519	68.16	83.04	1363.0	830.4
2	5XM	289.9	36.24	.4174	10.440	24.87	34.65	497.4	346.5
3	9XM	768.3	96.04	.5409	13.520	39.89	67.90	797.8	679.0
4	23XM	890.7	111.30	.4115	10.290	62.37	108.50	1247.0	1085.0
5	25XM	856.9	107.10	.4269	10.670	58.37	101.10	1167.0	1011.0
6	27XM	963.2	120.40	.4566	11.420	62.47	105.90	1249.0	1059.0
Mean:		783.3	97.92	.4390	10.980	52.69	83.50	1054.0	835.0
Standard Deviation:		250.9	31.36	.0556	1.390	16.73	28.51	334.5	285.1
CofofVar:		32.03	32.03	12.66	12.66	31.74	34.14	31.74	34.14

Table C.8 ASTM 4595 Group B GG 10 Cross Direction.

US Army Engineer Waterways Exp. Station
Geotechnical Laboratory
Airfields and Pavements Division

Geotextile Tensile Test - ASTM D 4595
Secant Modulus at 5% and 10% Elongation
T.C. - 12/97

Test type:	Tensile	Instron Corporation
Operator name:	GOODIN	Series IX Automated Materials Testing System 6.04
		Test Date: 26 Jan 1998
Sample Identification:	mgd24m	Sample Type: FAB.
Interface Type:	42/43/4400 Series	
Machine Parameters of test:		
Sample Rate (pts/sec):	2.000	Humidity (%): 50
Crosshead Speed (in/min):	.4000	Temperature (deg. F): 73

Dimensions:

	Spec. 1	Spec. 2	Spec. 3	Spec. 4	Spec. 5	Spec. 6
Width (in)	8.0000	8.0000	8.0000	8.0000	8.0000	8.0000
Thickness (in)	1.0000	1.0000	1.0000	1.0000	1.0000	1.0000
Spec gauge len (in)	4.0000	4.0000	4.0000	4.0000	4.0000	4.0000
Grip distance (in)	4.0000	4.0000	4.0000	4.0000	4.0000	4.0000

Out of 6 specimens, 0 excluded.

Sample comments:

Specimen Number	Specimen #	Load at Max. Load (lbs)	Tensile Strength @ Max. Load (lbs/in)	Displcment at Max. Load (in)	Elongation at Max. Load (%)	Tensile Str. @ 5% Elongation (lbs/in)	Tensile Str. @ 10% Elongation (lbs/in)	Secant Mod @ 5% Elongation (lbs/in)	Secant Mod @ 10% Elongation (lbs/in)
1	1M	5654.	706.7	.6376	15.94	426.4	611.6	8529.	6116.
2	4M	5579.	697.4	.6537	16.39	421.4	613.6	8428.	6136.
3	9M	5339.	667.4	.5395	13.49	444.6	612.1	8892.	6121.
4	17M	4943.	617.9	.6341	15.85	403.2	553.7	8064.	5537.
5	26M	4420.	552.5	.4587	11.47	424.4	543.1	8489.	5431.
6	28M	3701.	462.6	.4081	10.20	383.6	462.0	7672.	4620.
Mean:		4939.	617.4	.5556	13.89	417.3	566.0	8346.	5660.
Standard Deviation:		759.	94.9	.1042	2.61	21.1	59.9	423.	599.
CoFoFVar:		15.37	15.37	18.76	18.76	5.06	10.59	5.06	10.59

Table C.9 ASTM 4595 Group B GG 24 Machine Direction.

US Army Engineer Waterways Exp. Station
 Geotechnical Laboratory
 Airfields and Pavements Division

Geotextile Tensile Test - ASTM D 4595
 Secant Modulus at 5% and 10% Elongation
 T.C. - 12/97

Test type: Tensile
 Operator name: GOODIN
 Sample Identification: MGD24XM
 Interface Type: 4200 Series
 Machine Parameters of test:
 Sample Rate (pts/sec): 2.000
 Crosshead Speed (in/min): .4000
 Instron Corporation
 Series IX Automated Materials Testing System 6.02
 Test Date: 23 Jan 1998
 Sample Type: FAB.
 Humidity (%): 50
 Temperature (deg. F): 73

Dimensions:
 Spec. 1 Spec. 2 Spec. 3 Spec. 4 Spec. 5 Spec. 6
 Width (in) 8.0000 8.0000 8.0000 8.0000 8.0000 8.0000
 Thickness (in) .10000 .10000 .10000 .10000 .10000 .10000
 Spec gauge len (in) 4.0000 4.0000 4.0000 4.0000 4.0000 4.0000
 Grip distance: (in) 4.0000 4.0000 4.0000 4.0000 4.0000 4.0000

Out of 6 specimens, 0 excluded.

Sample comments:

Specimen Number	Specimen #	Load at Max.Load (lbs)	Tensile Strength ● Max.Load (lbs/in)	Displcmnt at Max.Load (in)	Elongation at Max.Load (%)	Tensile Str. ● 5% Elongation (lbs/in)	Tensile Str. ● 10% Elongation (lbs/in)	Secant Mod ● 5% Elongation (lbs/in)	Secant Mod ● 10% Elongation (lbs/in)
1	2XM	1777.	222.1	1.609	40.22	34.61	71.44	692.2	714.4
2	7XM	1482.	185.2	1.354	33.85	50.16	78.94	1003.0	789.4
3	10XM	1770.	221.2	1.544	38.60	29.58	71.24	591.5	712.4
4	12XM	1769.	221.1	1.461	36.52	42.96	78.49	859.3	784.9
5	16XM	1770.	221.2	1.493	37.33	38.84	76.64	776.7	766.4
6	27XM	1835.	229.4	1.470	36.75	52.25	82.39	1045.0	823.9
Mean:		1734.	216.7	1.488	37.21	41.40	76.52	828.0	765.2
Standard Deviation:		126.	15.8	.086	2.14	8.83	4.43	176.5	44.3
CofOfVar:		7.27	7.27	5.76	5.76	21.32	5.78	21.32	5.78

Table C.10 ASTM 4595 Group B GG 24 Cross Direction.

US Army Engineer Waterways Exp. Station
 Geotechnical Laboratory
 Airfields and Pavements Division

Geotextile Tensile Test - ASTM D 4595
 Secant Modulus at 5% and 10% Elongation
 T.C. - 12/97

Test type: Tensile Instron Corporation
 Operator name: GOODIN Series IX Automated Materials Testing System 6.04
 Sample Identification: COM350M Test Date: 28 Jan 1998
 Interface Type: 42/43/4400 Series Sample Type: FAB.
 Machine Parameters of test:
 Sample Rate (pts/sec): 2.000 Humidity (%): 50
 Crosshead Speed (in/min): .4000 Temperature (deg. F): 73

Dimensions:

	Spec. 1	Spec. 2	Spec. 3	Spec. 4	Spec. 5	Spec. 6
Width (in)	8.0000	8.0000	8.0000	8.0000	8.0000	8.0000
Thickness (in)	.10000	.10000	.10000	.10000	.10000	.10000
Spec gauge len (in)	4.0000	4.0000	4.0000	4.0000	4.0000	4.0000
Grip distance: (in)	4.0000	4.0000	4.0000	4.0000	4.0000	4.0000

Out of 6 specimens, 0 excluded.

Sample comments:

Specimen Number	Specimen #	Load	Tensile	Displcment	Elongation	Tensile	Tensile	Secant Mod	Secant Mod
		at Max.Load (lbs)	Strength * Max.Load (lbs/in)	at Max.Load (in)	at Max.Load (%)	Str. * 5% (lbs/in)	Str. * 10% (lbs/in)	Elongation * 5% (lbs/in)	Elongation * 10% (lbs/in)
1	3M	9941.	1243.0	.7677	19.19	359.3	652.8	7186.	6528.
2	5M	8811.	1101.0	.7315	18.29	372.1	628.9	7442.	6289.
3	7M	9835.	1229.0	.7131	17.83	410.4	777.8	8207.	7778.
4	13M	11270.	1409.0	.7228	18.07	426.3	790.3	8527.	7903.
5	22M	10780.	1348.0	.8667	21.67	369.0	676.4	7379.	6764.
6	26M	4032.	504.0	.5032	12.58	220.0	426.0	4401.	4260.
Mean:		9112.	1139.0	.7175	17.94	359.5	658.7	7190.	6587.
Standard Deviation:		2629.	328.6	.1191	2.98	73.2	131.8	1463.	1318.
CofOfVar:		28.85	28.85	16.60	16.60	20.35	20.01	20.35	20.01

Table C.11 ASTM 4595 Group A COM GT 350 Machine Direction.

US Army Engineer Waterways Exp. Station
Geotechnical Laboratory
Airfields and Pavements Division

Geotextile Tensile Test - ASTM D 4595
Secant Modulus at 5% and 10% Elongation
T.C. - 12/97

Test type: Tensile

Instron Corporation
Series IX Automated Materials Testing System 6.04
Test Date: 29 Jan 1998

Operator name: GOODIN

Sample Identification: COM350XM
Interface Type: 42/43/4400 Series

Sample Type: FAB.

Machine Parameters of test:

Sample Rate (pts/sec): 2.000
Crosshead Speed (in/min): .4000

Humidity (%): 50
Temperature (deg. F): 73

Dimensions:

	Spec. 1	Spec. 2	Spec. 3	Spec. 4	Spec. 5	Spec. 6
Width (in)	8.0000	8.0000	8.0000	8.0000	8.0000	8.0000
Thickness (in)	.10000	.10000	.10000	.10000	.10000	.10000
Spec gauge len (in)	4.0000	4.0000	4.0000	4.0000	4.0000	4.0000
Grip distance (in)	4.0000	4.0000	4.0000	4.0000	4.0000	4.0000

Out of 6 specimens, 0 excluded.

Sample comments:

Specimen Number	Specimen #	Load at Max. Load (lbs)	Tensile Strength • Max. Load (lbs/in)	Displment at Max. Load (in)	Elongation at Max. Load (%)	Tensile Str. • 5% Elongation (lbs/in)	Tensile Str. • 10% Elongation (lbs/in)	Secant Mod • 5% Elongation (lbs/in)	Secant Mod • 10% Elongation (lbs/in)
1	2XM	4557.	569.6	.6141	15.35	228.4	402.7	4568.	4027.
2	4XM	5475.	684.4	.6210	15.52	242.0	454.5	4839.	4545.
3	25XM	4726.	590.7	.5723	14.31	226.7	433.0	4534.	4330.
4	27XM	5219.	652.4	.5894	14.73	237.1	456.6	4742.	4566.
5	31XM	4988.	623.5	.6391	15.98	210.3	402.5	4206.	4025.
6	34XM	4549.	568.6	.5001	12.50	242.1	483.0	4842.	4830.
Mean:		4919.	614.9	.5893	14.73	231.1	438.7	4622.	4387.
Standard Deviation:		377.	47.1	.0497	1.24	12.1	32.2	242.	322.
CofoIVar:		7.66	7.66	8.43	8.43	5.24	7.33	5.24	7.33

Table C.12 ASTM 4595 Group A COM GT 350 Cross Direction.

US Army Engineer Waterways Exp. Station
 Geotechnical Laboratory
 Airfields and Pavements Division

Geotextile Tensile Test - ASTM D 4595
 Secant Modulus at 5% and 10% Elongation
 T.C. - 12/97

Test type: Tensile
 Operator name: GOODIN
 Sample Identification: COM500M
 Interface Type: 4200 Series
 Machine Parameters of test:
 Sample Rate (pts/sec): 2.000
 Crosshead Speed (in/min): .4000

Instron Corporation
 Series IX Automated Materials Testing System 6.02
 Test Date: 21 Jan 1998
 Sample Type: FAB.
 Humidity (%): 50
 Temperature (deg. F): 73

Dimensions:

	Spec. 1	Spec. 2	Spec. 3	Spec. 4	Spec. 5	Spec. 6
Width (in)	8.0000	8.0000	8.0000	8.0000	8.0000	8.0000
Thickness (in)	.10000	.10000	.10000	.10000	.10000	.10000
Spec gauge len (in)	4.0000	4.0000	4.0000	4.0000	4.0000	4.0000
Grip distance: (in)	4.0000	4.0000	4.0000	4.0000	4.0000	4.0000

Out of 6 specimens, 0 excluded.

Sample comments:

Specimen Number	Specimen #	Load at Max. Load (lbs)	Tensile Strength * (lbs/in)	Displcmnt at Max. Load (in)	Elongation at Max. Load (%)	Tensile Str. @ 5% Elongation (lbs/in)	Tensile Str. @ 10% Elongation (lbs/in)	Secant Mod @ 5% Elongation (lbs/in)	Secant Mod @ 10% Elongation (lbs/in)
1	1M	12080.	1510.0	.6559	16.40	554.7	1011.0	11090.	10110.
2	4M	10990.	1374.0	.6350	15.88	484.3	903.3	9687.	9033.
3	6M	13480.	1685.0	.7551	18.88	499.8	920.7	9977.	9207.
4	14M	12190.	1524.0	.7437	18.59	488.9	834.1	9779.	8341.
5	27M	7193.	899.1	.4971	12.43	496.3	812.4	9926.	8124.
6	31M	14500.	1813.0	.8024	20.06	478.3	923.4	9566.	9234.
Mean:		11740.	1467.0	.6815	17.04	500.4	900.8	10010.	9008.
Standard Deviation:		2538.	317.2	.1102	2.76	27.7	71.1	555.	711.
CoofVar:		21.62	21.62	16.17	16.17	5.54	7.89	5.54	7.89

Table C.13 ASTM 4595 Group A COM GT 500 Machine Direction.

US Army Engineer Waterways Exp. Station
Geotechnical Laboratory
Airfields and Pavements Division

Geotextile Tensile Test - ASTM D 4595
Secant Modulus at 5% and 10% Elongation
T.C. - 12/97

Test type: Tensile	Instron Corporation
Operator name: GOODIN	Series IX Automated Materials Testing System 6.02
	Test Date: 21 Jan 1998
Sample Identification: COM500XM	Sample Type: FAB.
Interface Type: 4200 Series	
Machine Parameters of test:	
Sample Rate (pts/sec): 2.000	Humidity (%): 50
Crosshead Speed (in/min): .4000	Temperature (deg. F): 73

Dimensions:

	Spec. 1	Spec. 2	Spec. 3	Spec. 4	Spec. 5	Spec. 6
Width (in)	8.0000	8.0000	8.0000	8.0000	8.0000	8.0000
Thickness (in)	.10000	.10000	.10000	.10000	.10000	.10000
Spec gauge len (in)	4.0000	4.0000	4.0000	4.0000	4.0000	4.0000
Grip distance (in)	4.0000	4.0000	4.0000	4.0000	4.0000	4.0000

Out of 6 specimens, 0 excluded.

Sample comments:

Specimen Number	Specimen #	Load at Max.Load (lbs)	Tensile Strength at Max.Load (lbs/in)	Displment at Max.Load (in)	Elongation at Max.Load (%)	Tensile Str. at 5% Elongation (lbs/in)	Tensile Str. at 10% Elongation (lbs/in)	Secant Mod at 5% Elongation (lbs/in)	Secant Mod at 10% Elongation (lbs/in)
1	5XM	3234.	404.3	.5562	13.910	97.39	265.4	1948.	2654.
2	8XM	3518.	439.7	.4995	12.490	186.20	364.3	3724.	3643.
3	9XM	3523.	440.4	.4887	12.220	194.50	383.5	3889.	3835.
4	16XM	2746.	343.2	.3474	8.686	216.60	-----	4331.	-----
5	28XM	3279.	409.9	.4449	11.120	196.90	378.7	3939.	3787.
6	33XM	3136.	392.0	.4094	10.230	200.50	384.7	4011.	3847.
Mean:		3239.	404.9	.4577	11.440	182.00	-----	3640.	-----
Standard Deviation:		288.	36.0	.0736	1.840	42.64	-----	853.	-----
CoFoFVar:		8.88	8.88	16.08	16.08	23.43	-----	23.43	-----

Table C.14 ASTM 4595 Group A COM GT 500 Cross Direction.

US Army Engineer Waterways Exp. Station
 Geotechnical Laboratory
 Airfields and Pavements Division

Geotextile Tensile Test - ASTM D 4595
 Secant Modulus at 5% and 10% Elongation
 T.C. - 12/97

Test type: Tensile
 Operator name: GOODIN
 Sample Identification: KBV PARA
 Interface Type: 42/43/4400 Series
 Machine Parameters of test:
 Sample Rate (pts/sec): 2.000
 Crosshead Speed (in/min): .4000
 Instron Corporation
 Series IX Automated Materials Testing System 6.04
 Test Date: 29 Jan 1998
 Sample Type: FAB.
 Humidity (%): 50
 Temperature (deg. F): 73

Dimensions:
 Spec. 1 Spec. 2 Spec. 3 Spec. 4 Spec. 5 Spec. 6
 Width (in) 8.0000 8.0000 8.0000 8.0000 8.0000 8.0000
 Thickness (in) .10000 .10000 .10000 .10000 .10000 .10000
 Spec gauge len (in) 4.0000 4.0000 4.0000 4.0000 4.0000 4.0000
 Grip distance: (in) 4.0000 4.0000 4.0000 4.0000 4.0000 4.0000

Out of 6 specimens, 0 excluded.

Sample comments:

Specimen Number	Specimen #	Load at Max.Load (lbs)	Tensile Strength * (lbs/in)	Displcmnt at Max.Load (in)	Elongation at Max.Load (%)	Tensile Str. * 5% Elongation (lbs/in)	Tensile Str. * 10% Elongation (lbs/in)	Secant Mod * 5% Elongation (lbs/in)	Secant Mod * 10% Elongation (lbs/in)
1	1PA	5451.	681.4	.2803	7.008	549.1	-----	10980.	-----
2	12PA	5626.	728.5	.3137	7.841	541.7	-----	10830.	-----
3	13PA	5425.	678.1	.2907	7.268	519.3	-----	10390.	-----
4	11PA	5212.	651.5	.2787	6.968	560.3	-----	11210.	-----
5	6PA	5344.	668.0	.2876	7.189	547.8	-----	10960.	-----
6	15PA	5133.	641.6	.3193	7.984	506.1	-----	10120.	-----
Mean:		5399.	674.9	.2951	7.376	537.4	-----	10750.	-----
Standard Deviation:		243.	30.4	.0173	.432	20.5	-----	410.	-----
CofofVar:		4.51	4.51	5.86	5.86	3.81	-----	3.81	-----

Table C.15 ASTM 4595 Group A COM K 1084 Machine Direction.

US Army Engineer Waterways Exp. Station
 Geotechnical Laboratory
 Airfields and Pavements Division

Geotextile Tensile Test - ASTM D 4595
 Secant Modulus at 5% and 10% Elongation
 T.C. - 12/97

Test type: Tensile
 Operator name: goodin
 Sample Identification: KEVPERP
 Interface Type: 42/43/4400 Series
 Machine Parameters of test:
 Sample Rate (pts/sec): 2.000
 Crosshead Speed (in/min): .4000
 Instron Corporation
 Series IX Automated Materials Testing System 6.04
 Test Date: 28 Jan 1998
 Sample Type: FAB.
 Humidity (%): 50
 Temperature (deg. F): 73

Dimensions:
 Spec. 1 Spec. 2 Spec. 3 Spec. 4 Spec. 5 Spec. 6
 Width (in) 8.0000 8.0000 8.0000 8.0000 8.0000 8.0000
 Thickness (in) .10000 .10000 .10000 .10000 .10000 .10000
 Spec gauge len (in) 4.0000 4.0000 4.0000 4.0000 4.0000 4.0000
 Grip distance (in) 4.0000 4.0000 4.0000 4.0000 4.0000 4.0000

Out of 6 specimens, 0 excluded.

Sample comments:

Specimen Number	Specimen #	Load at Max. Load (lbs)	Tensile Strength at Max. Load (lbs/in)	Displcment at Max. Load (in)	Elongation at Max. Load (%)	Tensile Str. at 5% Elongation (lbs/in)	Tensile Str. at 10% Elongation (lbs/in)	Secant Mod at 5% Elongation (lbs/in)	Secant Mod at 10% Elongation (lbs/in)
1	10PE	4446.	555.7	.3039	7.598	418.7	-----	8374.	-----
2	4PE	4753.	594.1	.2595	6.488	511.3	-----	10230.	-----
3	14PE	4977.	622.1	.2697	6.743	515.0	-----	10300.	-----
4	7PE	4855.	606.9	.2967	7.418	454.6	-----	9091.	-----
5	5PE	4984.	623.0	.2868	7.171	480.8	-----	9616.	-----
6	5PE	4879.	609.9	.2942	7.355	496.7	-----	9935.	-----
Mean:		4816.	602.0	.2851	7.129	479.5	-----	9590.	-----
Standard Deviation:		200.	25.0	.0171	.428	37.1	-----	742.	-----
CoFoFVar:		4.16	4.16	6.00	6.00	7.74	-----	7.74	-----

Table C.16 ASTM 4595 Group A K 1084 Cross Direction.

US Army Engineer Waterways Exp. Station
Geotechnical Laboratory
Airfields and Pavements Division

Geogrid Tensile Test

Test type: Tensile
Operator name: GOODIN
Sample Identification: UXM
Interface Type: 42/43/4400 Series
Machine Parameters of test:
Sample Rate (pts/sec): 2.000
Crosshead Speed (in/min): .4000

Instron Corporation
Series IX Automated Materials Testing System 6.04
Test Date: 30 Jan 1998
Sample Type: GRID
Humidity (%): 50
Temperature (deg. F): 73

Dimensions:
Width (in) .22000
Thickness (in) .06900
Spec gauge len (in) 4.0000
Grip distance: (in) 4.0000

Out of 6 specimens, 0 excluded.

Sample comments:

Specimen Number	Specimen #	Load at Max.Load (lbs)	Tensile Strength at Max.Load (lbs/in)	Displcmnt at Max.Load (in)	Elongation at Max.Load (%)	Tensile Str. @ 5% Elongation (lbs/in)	Tensile Str. @ 10% Elongation (lbs/in)	Secant Mod @ 5% Elongation (lbs/in)	Secant Mod @ 10% Elongation (lbs/in)
1	1M	240.1	1091.	.3546	8.866	840.4	814.3	16810.	8143.
2	2M	302.1	1373.	.4455	11.140	878.5	1319.0	17570.	13190.
3	3M	360.9	1640.	.5956	14.890	899.0	1366.0	17980.	13660.
4	4M	329.0	1495.	.5151	12.880	894.1	1351.0	17880.	13510.
5	5M	316.9	1440.	.5027	12.570	882.0	1329.0	17640.	13290.
6	6M	349.4	1588.	.5536	13.840	878.8	1377.0	17580.	13770.
Mean:		316.4	1438.	.4945	12.360	878.8	1259.0	17580.	12590.
Standard Deviation:		43.0	196.	.0851	2.126	20.6	219.1	413.	2191.
CofofVar:		13.60	13.60	17.20	17.20	2.35	17.40	2.35	17.40

Table C.17 ASTM 4595 Group B GG 1500 Machine Direction.

Mirafli HS 600 Machine Direction

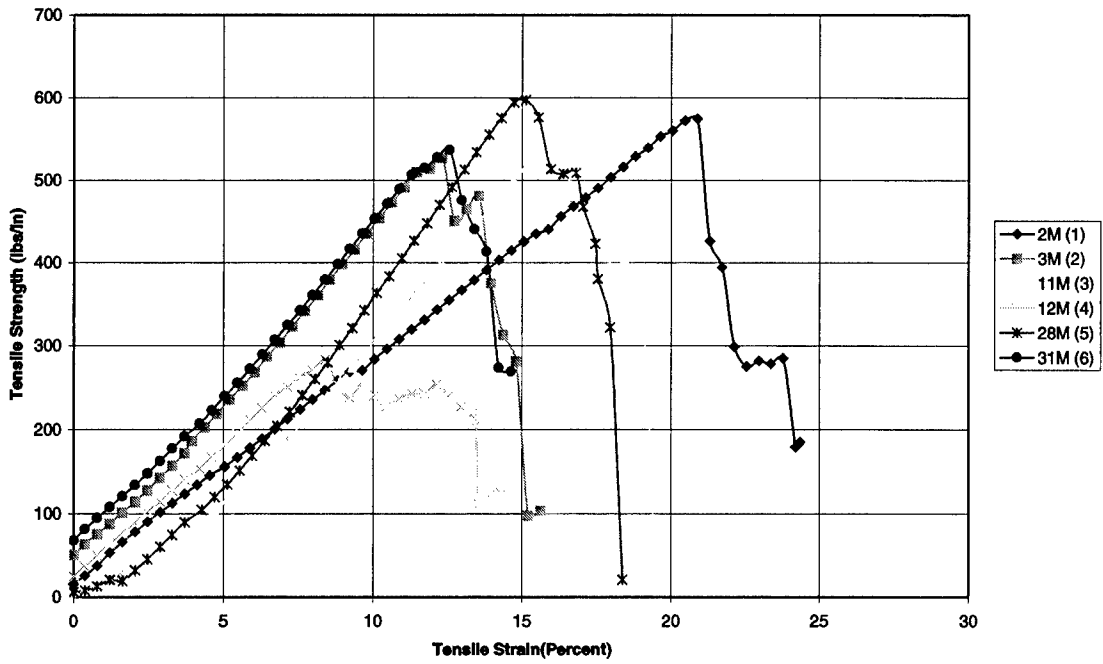

Figure C.1 ASTM 4595 Group A GT 600 Machine Direction.

Mirafli HS 600 Cross-Machine Direction

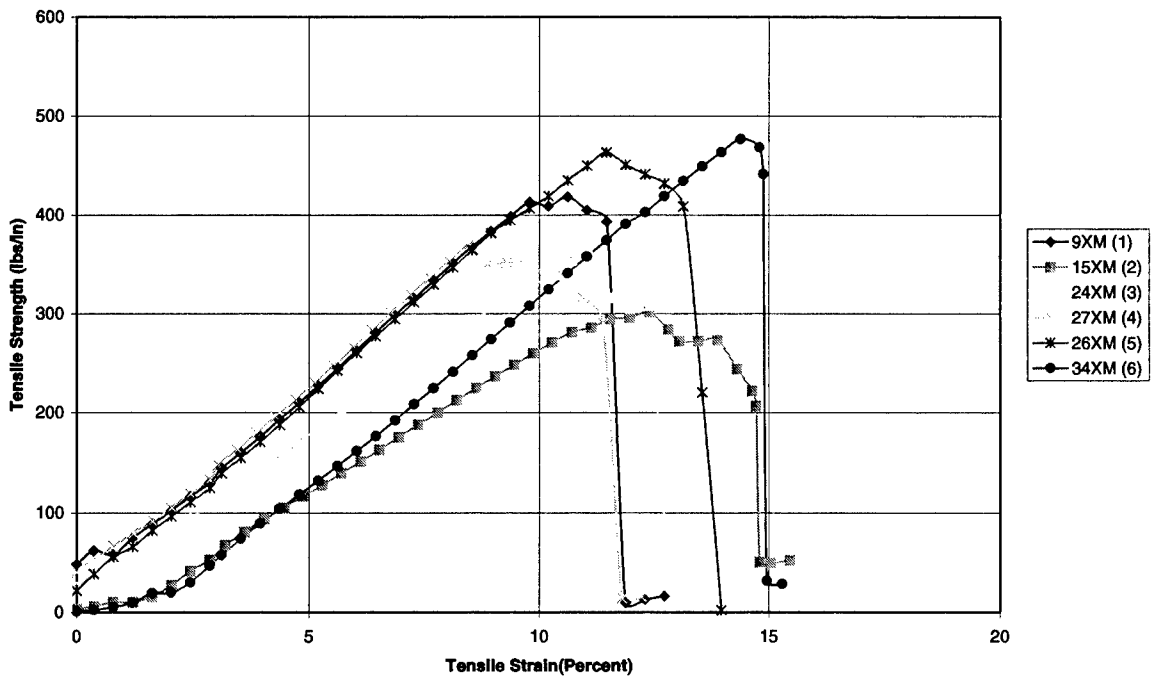

Figure C.2 ASTM 4595 Group A GT 600 Cross Direction.

Mirafi HS 800 Machine Direction

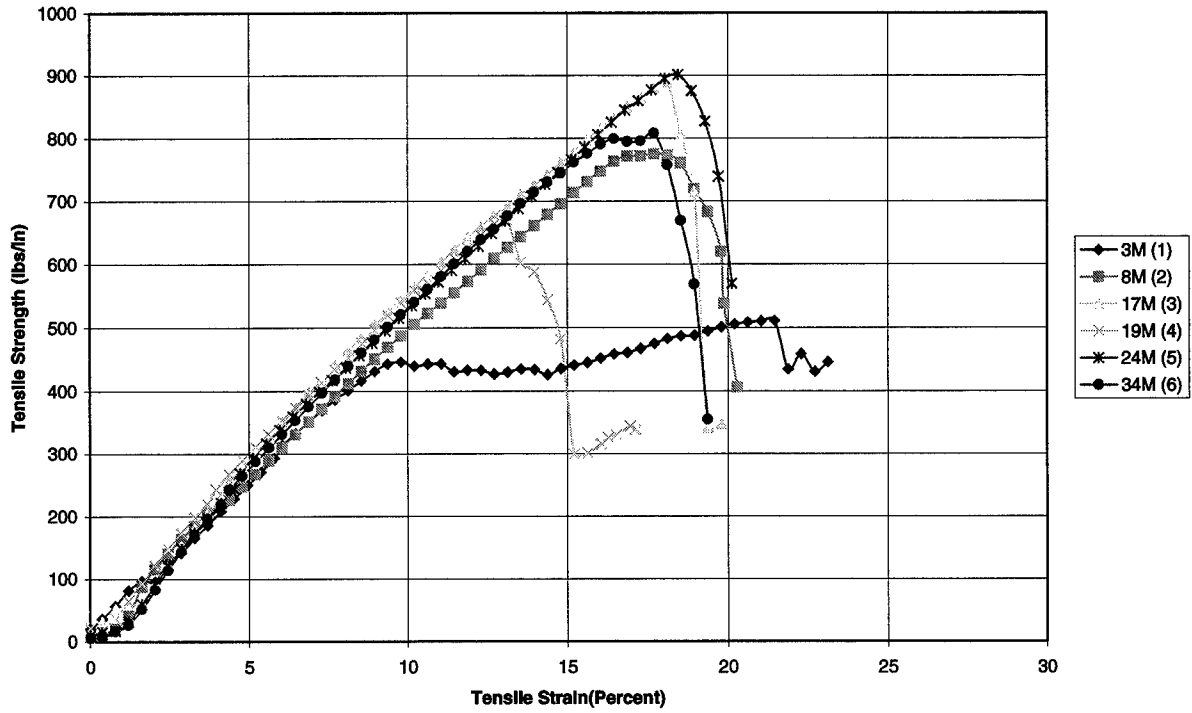

Figure C.3 ASTM 4595 Group A GT 800 Machine Direction.

Mirafi HS 800 Cross-Machine Direction

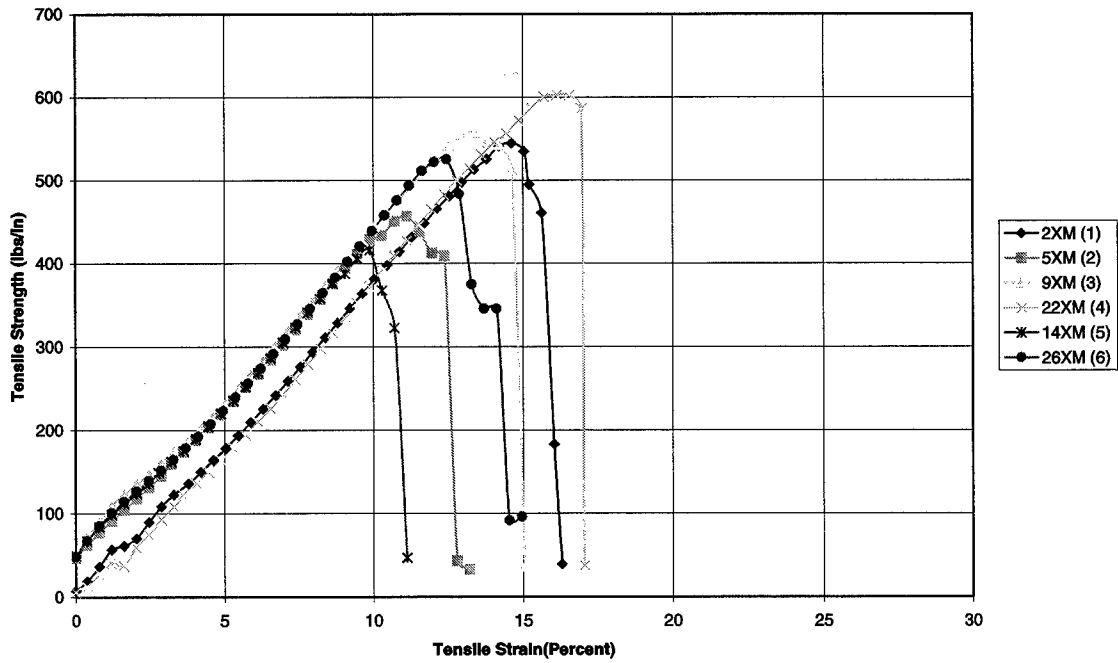

Figure C.4 ASTM 4595 Group A GT 800 Cross Direction.

Mirafi HS 1715 Machine Direction

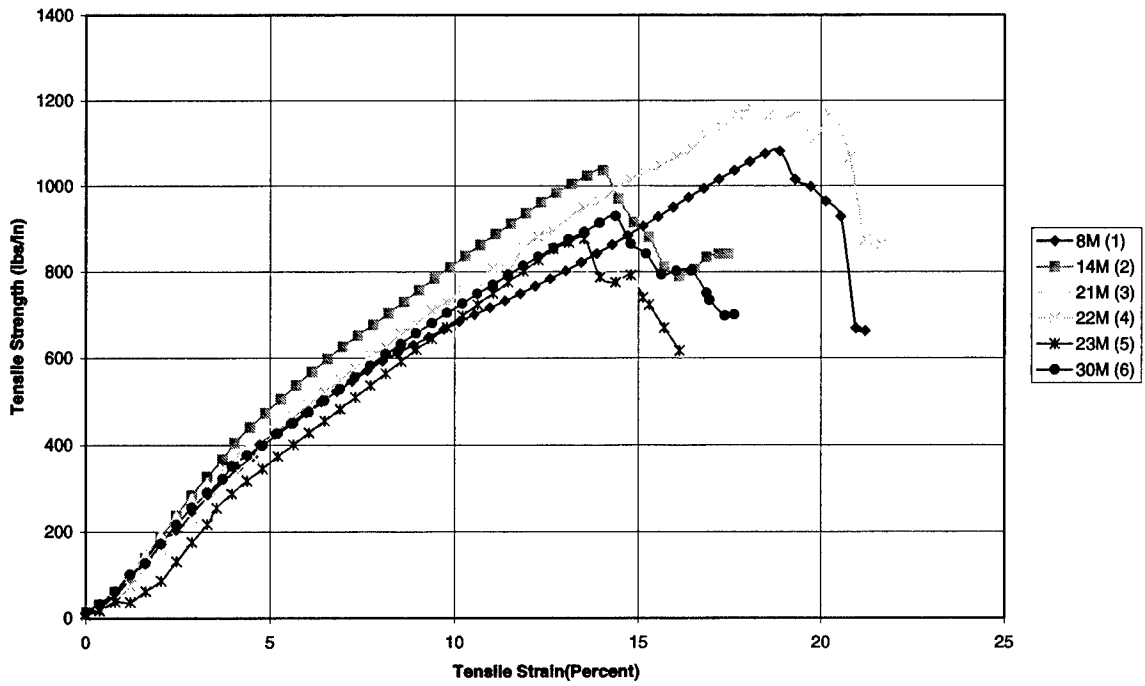

Figure C.5 ASTM 4595 Group A GT 1715 Machine Direction.

Mirafi HS 1715 Cross-Machine Direction

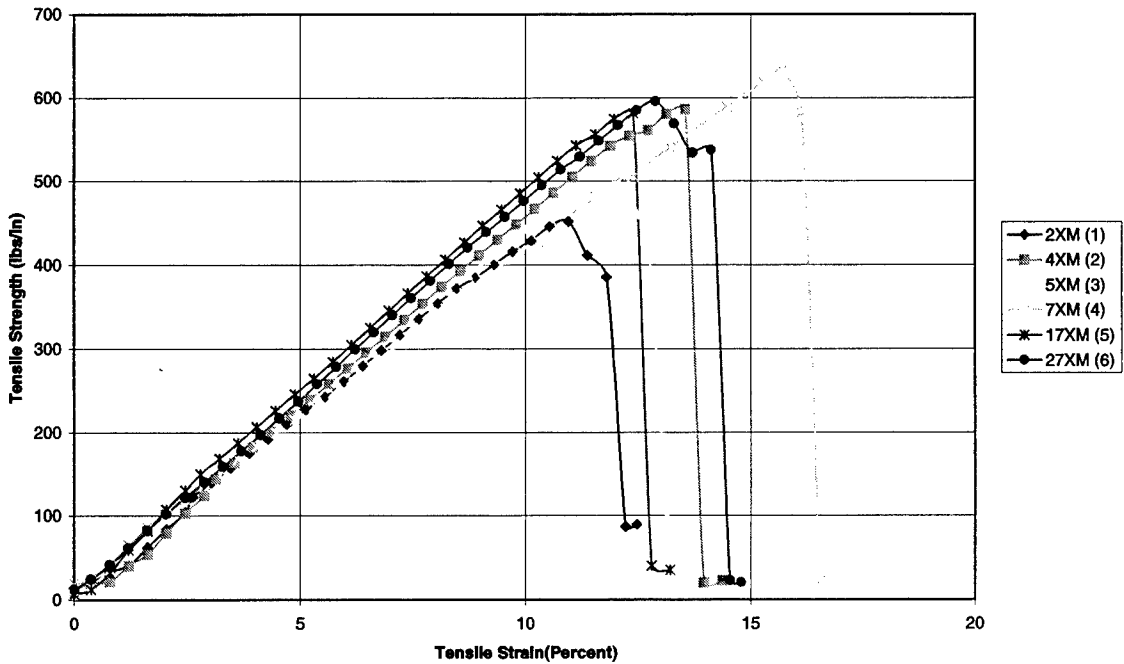

Figure C.6 ASTM 4595 Group A GT 1715 Cross Direction.

Miragrid 10XT Machine Direction

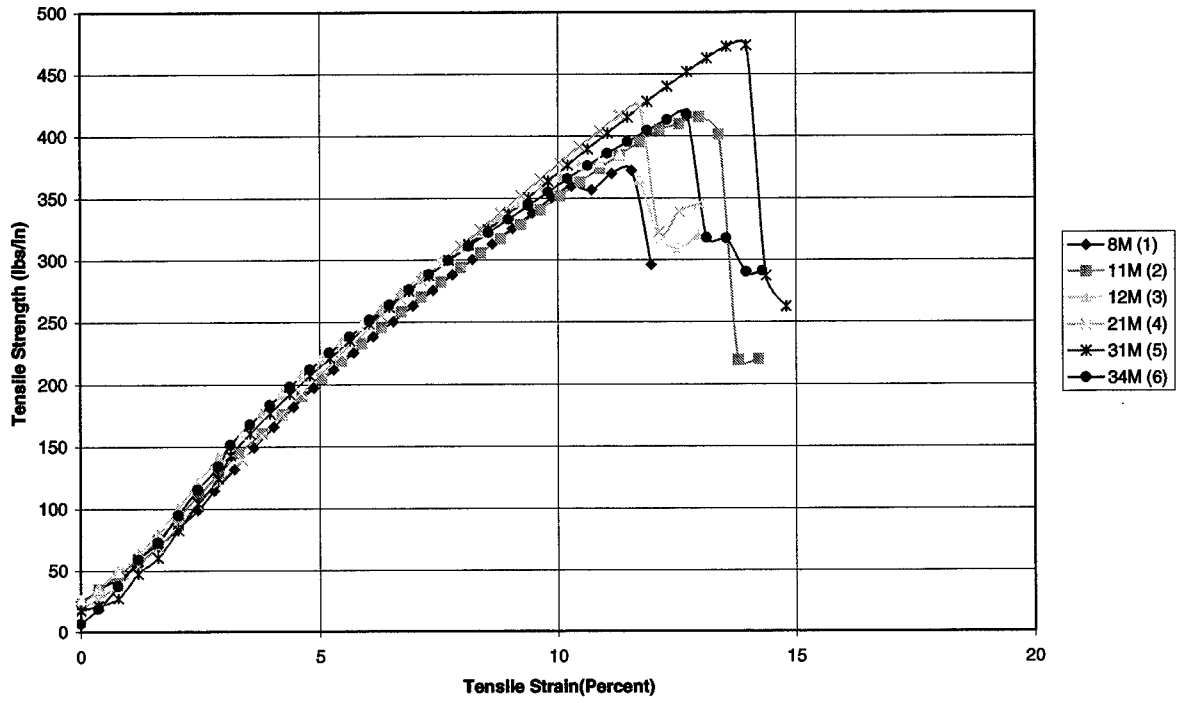

Figure C.7 ASTM 4595 Group B GG 10 Machine Direction.

Miragrid 10XT Cross- Machine Direction

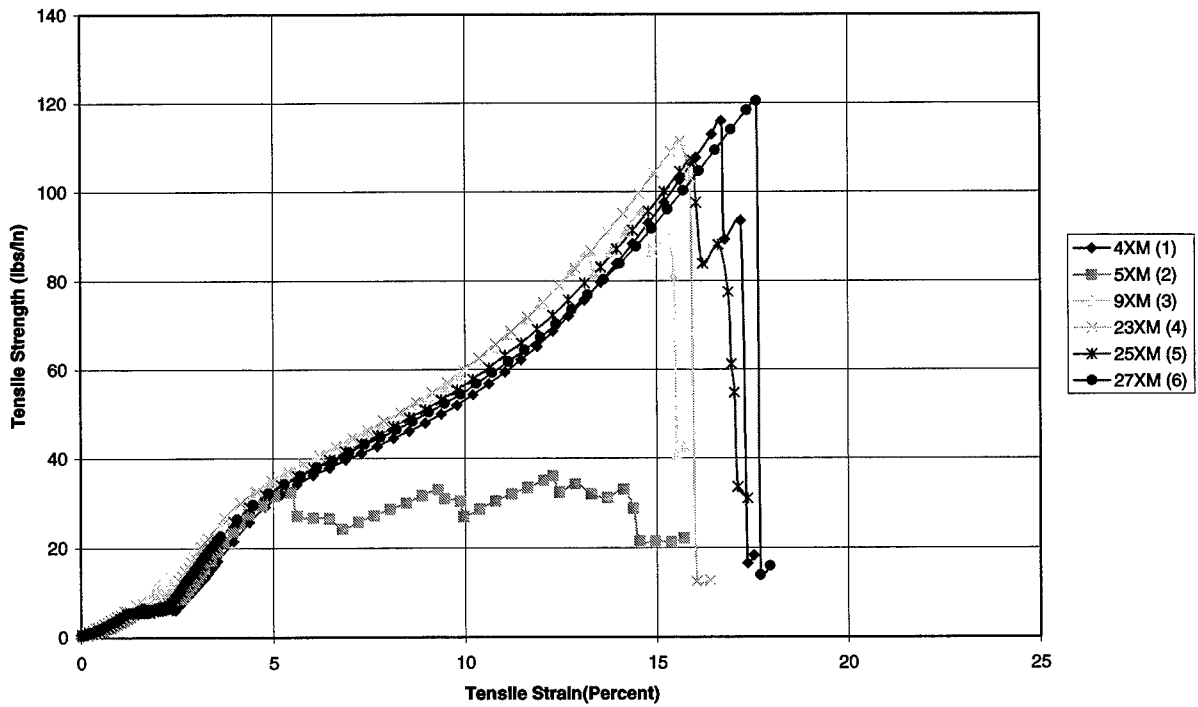

Figure C.8 ASTM 4595 Group B GG 10 Cross Direction.

Miragrid 24XT Machine Direction

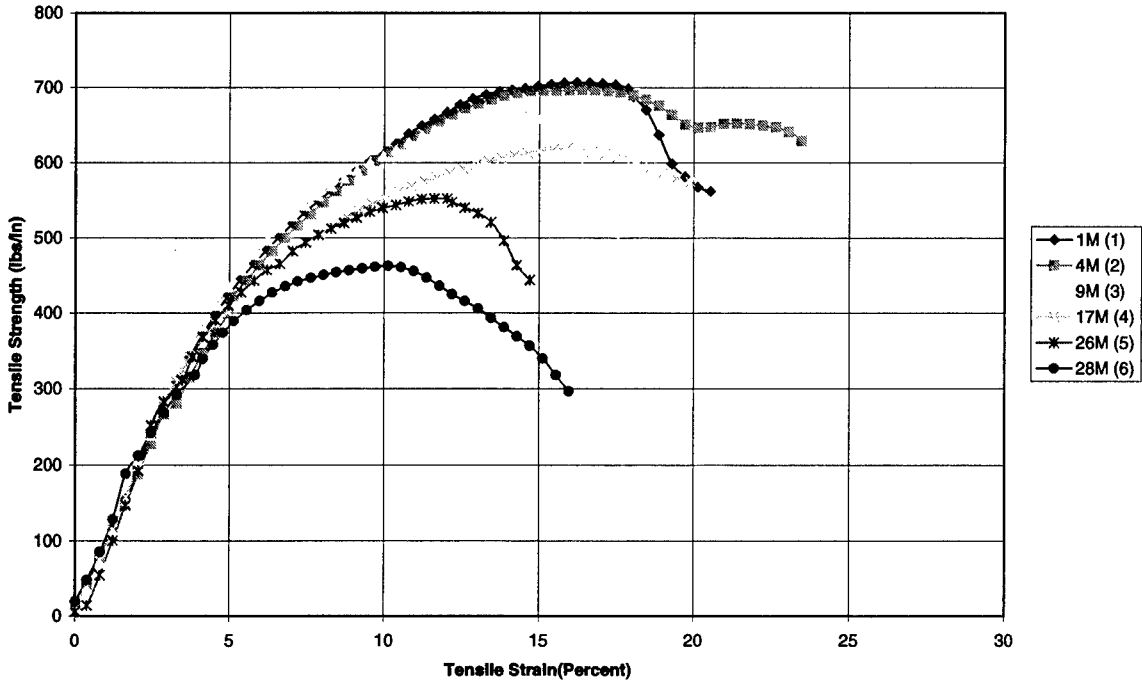

Figure C.9 ASTM 4595 Group B GG 24 Machine Direction.

Miragrid 24XT Cross- Machine Direction

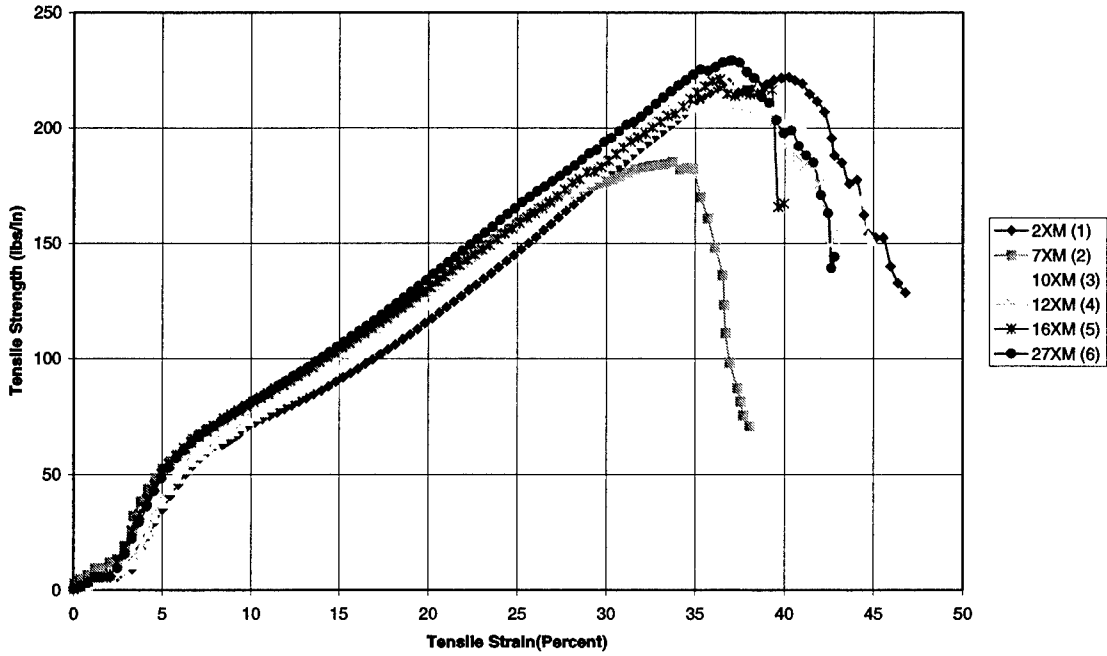

Figure C.10 ASTM 4595 Group B GG 24 Cross Direction.

Comtrac 350 Machine Direction

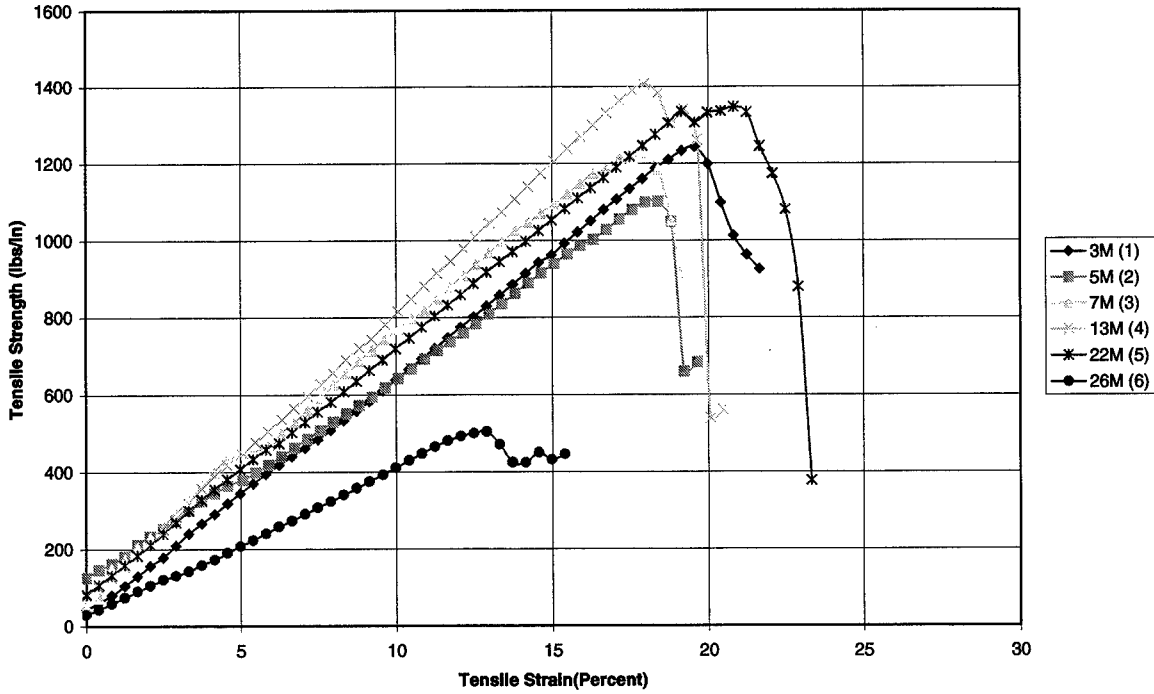

Figure C.11 ASTM 4595 Group A COM 350 Machine Direction.

Comtrac 350 Cross-Machine Direction

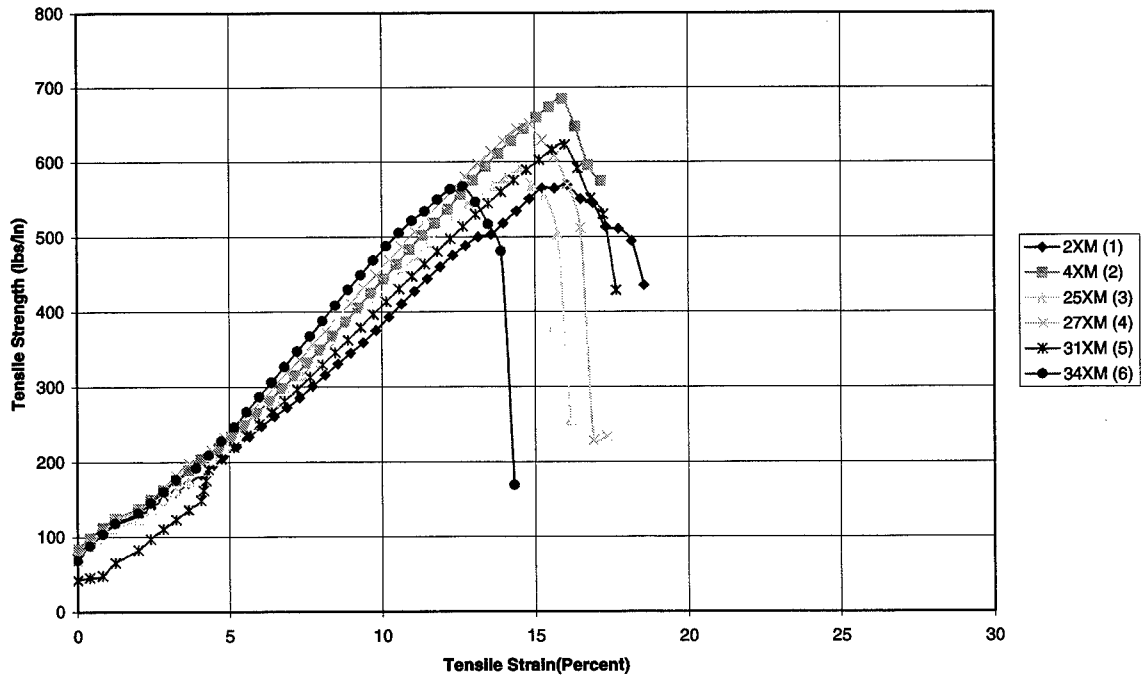

Figure C.12 ASTM 4595 Group A COM 350 Cross Direction.

Comtrac 500 Machine Direction

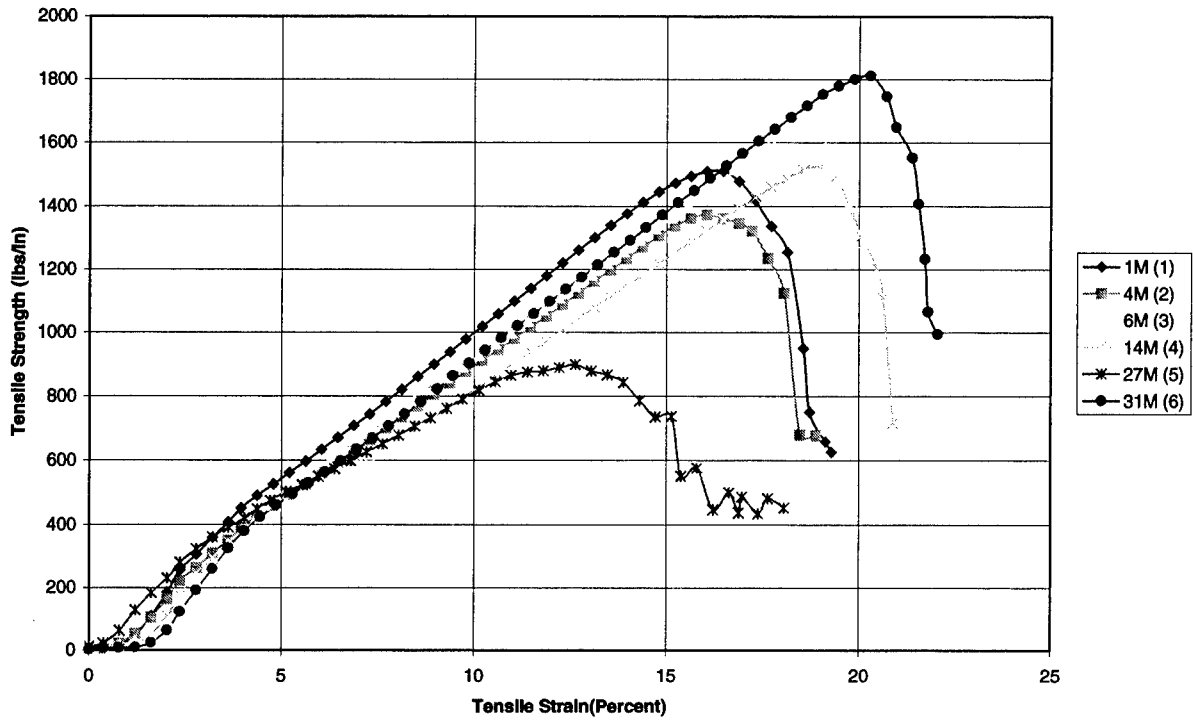

Figure C.13 ASTM 4595 Group A COM GT 500 Machine Direction.

Comtrac 500 Cross-Machine Direction

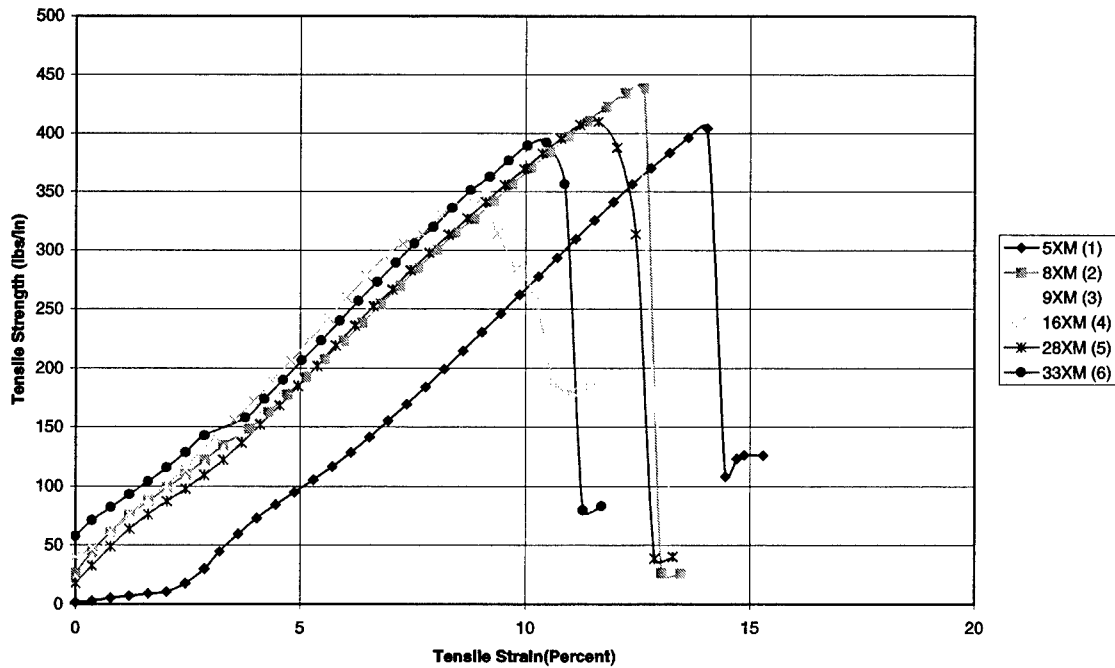

Figure C.14 ASTM 4595 Group A COM GT 500 Cross Direction.

Kevlar(Parallel) Machine Direction

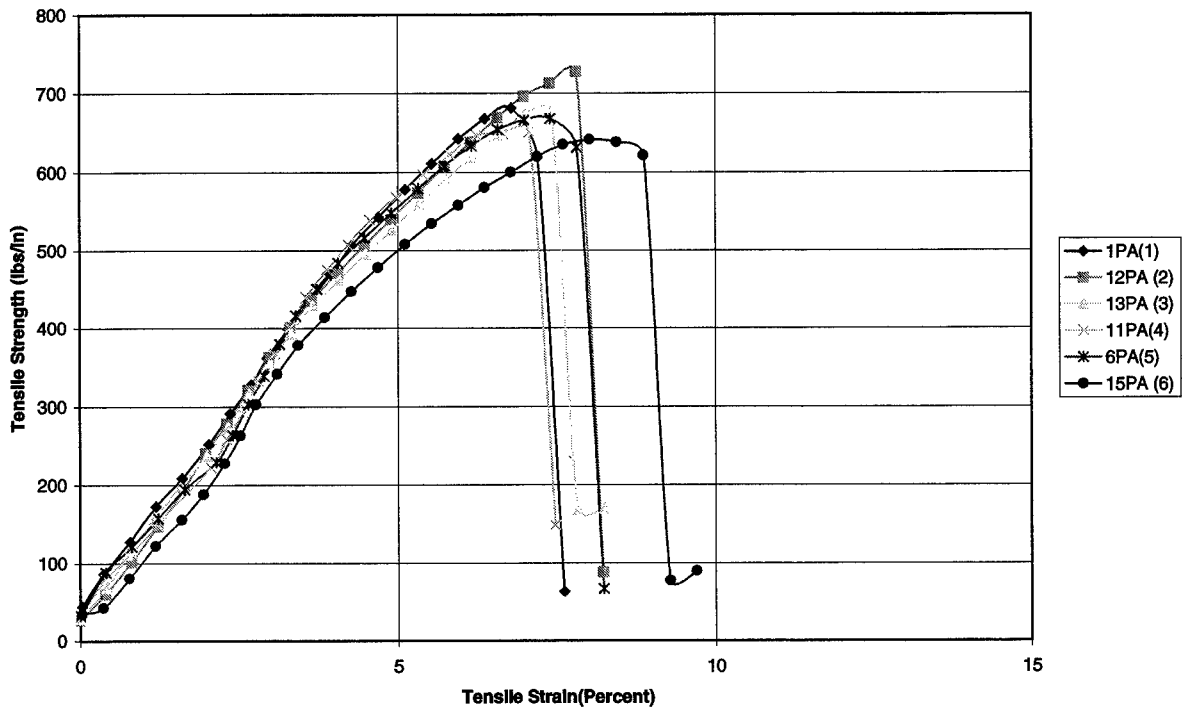
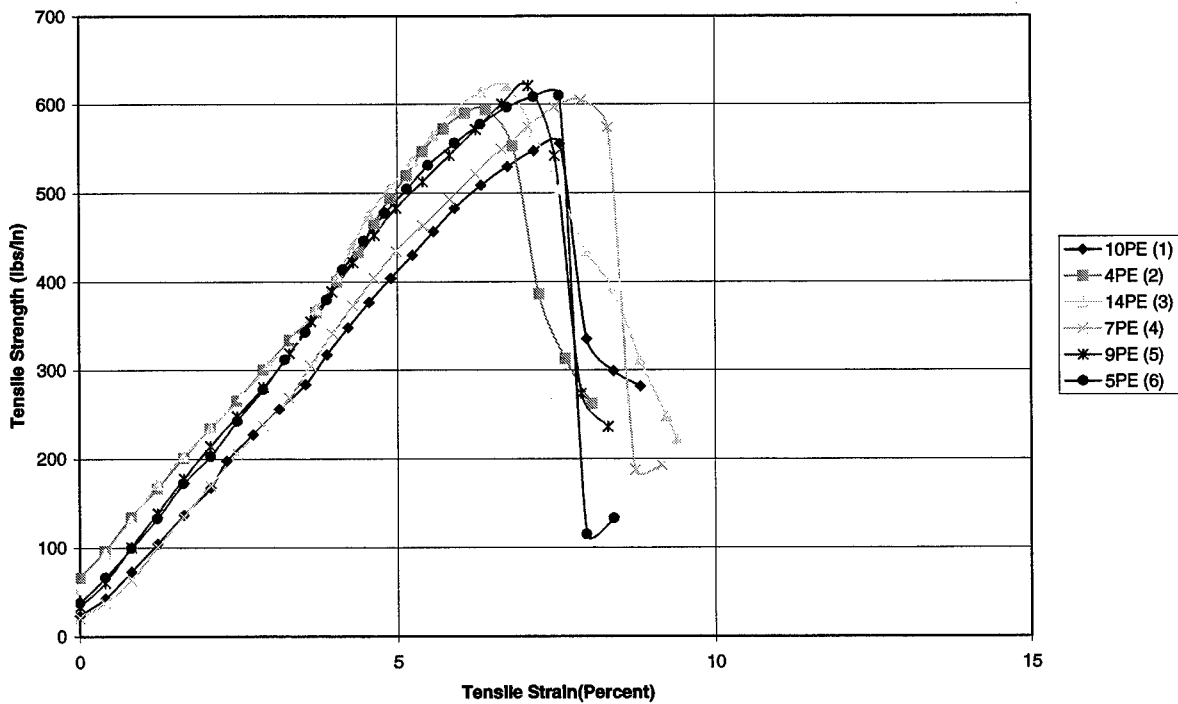

Figure C.15 ASTM 4595 Group A K 1084 Machine Direction.
Figure C.16 ASTM 4595 Group A K 1084 Cross Direction.

Kevlar (Perpendicular) Cross-Machine Direction



UX 1500 HS Machine Direction

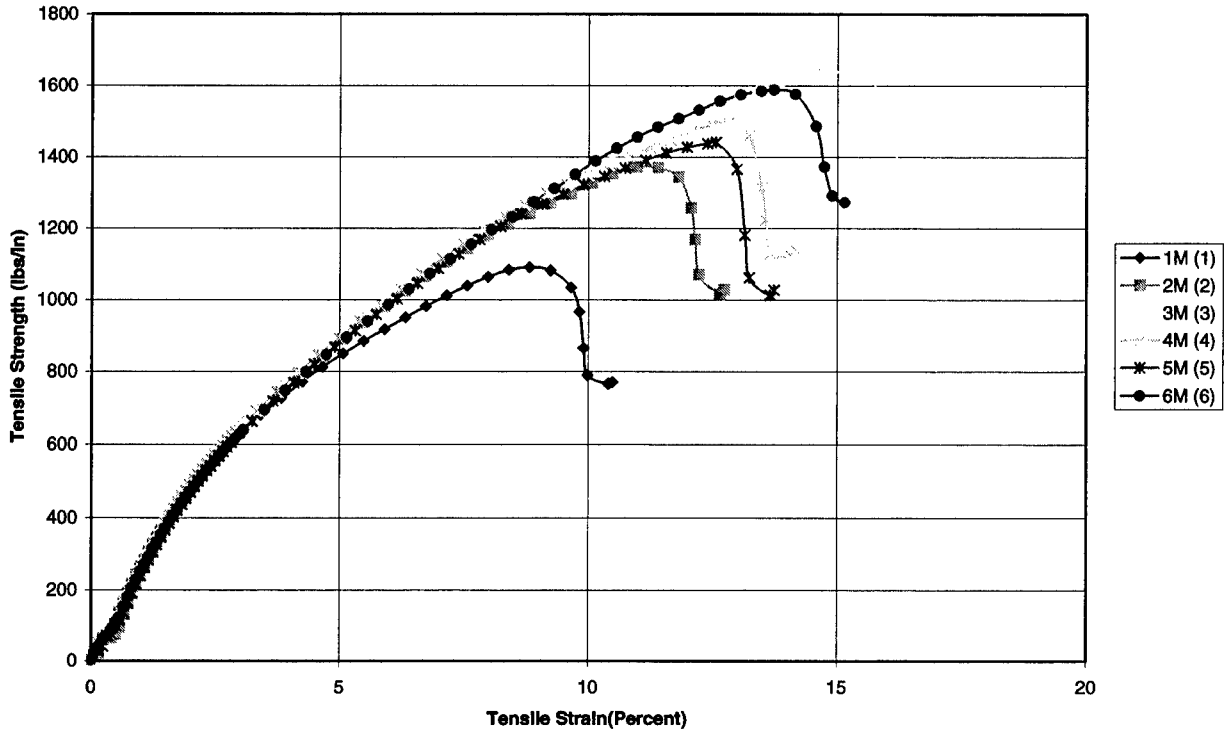

Figure C.17 ASTM 4595 Group B GG 1500 Machine Direction.

UX 1500 HS Cross-Machine Direction

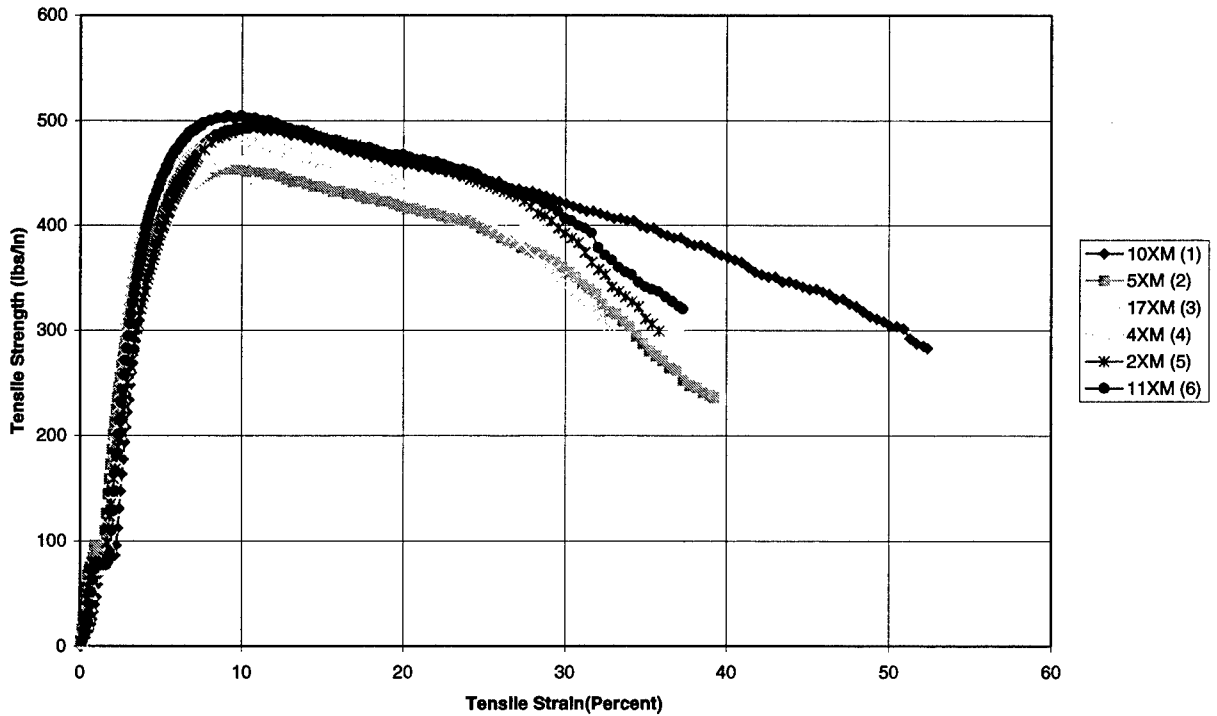

Figure C.18 ASTM 4595 Group B GG 1500 Cross Direction.

REPORT DOCUMENTATION PAGE

Form Approved
OMB No. 0704-0188

Public reporting burden for this collection of information is estimated to average 1 hour per response, including the time for reviewing instructions, searching existing data sources, gathering and maintaining the data needed, and completing and reviewing this collection of information. Send comments regarding this burden estimate or any other aspect of this collection of information, including suggestions for reducing this burden to Department of Defense, Washington Headquarters Services, Directorate for Information Operations and Reports (0704-0188), 1215 Jefferson Davis Highway, Suite 1204, Arlington, VA 22202-4302. Respondents should be aware that notwithstanding any other provision of law, no person shall be subject to any penalty for failing to comply with a collection of information if it does not display a currently valid OMB control number. **PLEASE DO NOT RETURN YOUR FORM TO THE ABOVE ADDRESS.**

1. REPORT DATE (DD-MM-YYYY) August 2000		2. REPORT TYPE Final Report		3. DATES COVERED (From - To)	
4. TITLE AND SUBTITLE Effects of an Anchoring Configuration on the Static Response of Geotextile and Geogrid Fabrics				5a. CONTRACT NUMBER	
				5b. GRANT NUMBER	
				5c. PROGRAM ELEMENT NUMBER	
6. AUTHOR(S) Lebron Simmons				5d. PROJECT NUMBER	
				5e. TASK NUMBER	
				5f. WORK UNIT NUMBER	
7. PERFORMING ORGANIZATION NAME(S) AND ADDRESS(ES) U.S. Army Engineer Research and Development Center Waterways Experiment Station 3909 Halls Ferry Road Vicksburg, MS 39180-6199				8. PERFORMING ORGANIZATION REPORT NUMBER ERDC/SL TR-00-5	
9. SPONSORING / MONITORING AGENCY NAME(S) AND ADDRESS(ES)				10. SPONSOR/MONITOR'S ACRONYM(S)	
				11. SPONSOR/MONITOR'S REPORT NUMBER(S)	
12. DISTRIBUTION / AVAILABILITY STATEMENT Approved for public release; distribution is unlimited.					
13. SUPPLEMENTARY NOTES					
14. ABSTRACT An investigation is made of a potential retrofit system for in-fill masonry walls subjected to blast effects that consist of geotextile or geogrid materials anchored to the roof, floor slabs and beams of conventional structures. Fourteen static tests on geotextile and geogrid materials were conducted to provide an initial evaluation of the performance of the retrofit systems. The ultimate capacity and load-deflection behavior of these retrofit systems, including connections, were determined. The static tests were conducted by slowly increasing the uniform load (water pressure) in a 6-ft-diam static chamber. The tensile strength of the materials used in the experiments varied from 575 lb/in. to 2,900 lb/in. Test loading pressures and structural response deflections were recorded. Resistance functions were developed from the experimental data for use in making dynamic response calculations. It was concluded from the experiments that the primary parameters affecting the capacity of the retrofit system were the material tensile strength, machine/cross-machine direction, and the anchoring system (bolt size and spacing).					
15. SUBJECT TERMS Geotextile Resistance function Uniform load Geogrid fabrics Ultimate capacity					
16. SECURITY CLASSIFICATION OF:			17. LIMITATION OF ABSTRACT	18. NUMBER OF PAGES	19a. NAME OF RESPONSIBLE PERSON
a. REPORT UNCLASSIFIED	b. ABSTRACT	c. THIS PAGE UNCLASSIFIED			19b. TELEPHONE NUMBER (include area code)