

Silent Inspector for Hydraulic Pipeline Dredges

PURPOSE: This technical note (TN) describes the Silent Inspector (SI) for Hydraulic Pipeline Dredges (HPD) and documents field experiences of the work unit. The SI work unit of the Dredging Operations and Environmental Research (DOER) Program was established to develop standards, specifications, and software for a standardized, automated dredging contract monitoring system. The purpose of this TN is to document the ongoing development of the HPDSI (Hydraulic Pipeline Dredge Silent Inspector).

BACKGROUND: The U.S. Army Corps of Engineers DOER Program is developing the standards and specifications of the HPDSI. The impetus for system development comes from a) the Corps' changing emphasis from that of a dredge owner to contract administrator, b) the need to document and ensure contractor compliance with the increasing number of State and Federal environmental regulations and permitting criteria, c) inspector manpower restrictions, and d) the availability of electronic sensors and low-cost computing and data storage capabilities that permit the development of such a system.

A previous TN (TN DOER-I1, July 1999) described how several Corps Districts are monitoring contractor pipeline dredges. Each District specifies how HPD operating parameters are to be documented. However, differences exist between their data collection efforts that do not allow the Corps, as a whole, to realize the maximum benefits it could otherwise. For instance, for the larger contractors that dredge for several different Districts, any monitoring disparity means increased costs to meet or change the monitoring requirements, which in turn translates into higher costs per cubic yard of material dredged.

The SI work unit of the DOER Program was established to develop standardized, automated monitoring systems for dredging activities Corps-wide. A previous work unit developed specifications and analysis software for a standard monitoring system for hopper dredges. The system provides information that assists Corps personnel in planning, estimating, contract quality assurance and contract dispute settlement. The system also makes dredge operation records more accessible, understandable, and usable Corps-wide for planning, estimating, and managing. This TN summarizes progress on the HPDSI system and documents some Corps experience during the first implementation.

FUNCTIONS OF THE CORPS INSPECTOR ON HYDRAULIC PIPELINE DREDGES:

The Corps inspector is the onsite agent responsible for ensuring the contractor's compliance with engineering plans and specifications for construction and maintenance dredging. Depending on grade level, the inspector has varying degrees of limited authority. This authority includes stopping the work for situations posing a direct threat of injury to life or property and making necessary interpretations of plans, specifications, change orders, and other contract modifications.

DISTRIBUTION STATEMENT A

Approved for Public Release
Distribution Unlimited

20001030 149

The inspectors ensure that the contractor's operating procedures and dredging equipment adhere to safety requirements and United States Coast Guard regulations. They must also maintain records and submit progress reports and daily logs for the dredging project. These reports document various parameters for payment purposes and aid in contract quality assurance. The dredge's time is distributed into various categories, such as time spent actually dredging, moving, breakdowns, and various types of delays. The inspector periodically checks the position of the dredge to assure that the dredge is operating within the designated site. Inspectors investigate controversial issues created by the progress of work and submit a written report of the findings. As the situation requires, they supplement the regular reports with various types of narrative information. This information can include field conditions, recommendations to facilitate dredging progress, matters pertaining to safety, or general material concerning the dredging project.

Within these broad requirements, Corps dredging personnel identified the following specific inspection objectives that might be better met with the assistance of a SI system

- Monitor dredging position (xyz coordinates).
- Monitor dredge production status.
- Provide trustworthy "facts" for dispute resolution.

Monitor Dredge Position. This objective is intended to satisfy several user needs. One need is to ensure that dredging operations do not stray into environmentally restricted areas. Another need is to assure dredging managers that the contractor is maximizing his effective dredging time by operating only within the designated prism and cut. A time-history of cutterhead or dustpan position in three dimensions is invaluable to the inspector in meeting these needs. The inspector needs to be able to review these data on the dredge, but back in the office as well (Figure 1).

Monitor Dredge Performance (Production Status). On-dredge performance monitoring is important in Corps contract management because it assists in:

- Verifying contractor claims of changed conditions affecting production.
- Knowing when the dredge was actually dredging.
- Having an alternative to surveys for dredge production estimation.
- Improving estimates by providing detailed parameters to dredge performance models.
- Providing timely feedback to the Corps and contractors on production efficiency.

Two main operational parameters can be practically monitored to describe the dredge's activities in time and space. The two parameters are the cutterhead's (dustpan) 3-dimensional position and a production indicator. Monitoring results can feed directly into automated reporting of dredge position and dredge production.

Production is typically monitored onboard the dredge by measuring the flow velocity and density in the pipeline. These two measurements are usually combined into another instrument called a production meter. If installed correctly and calibrated (Pankow 1990), these meters can give

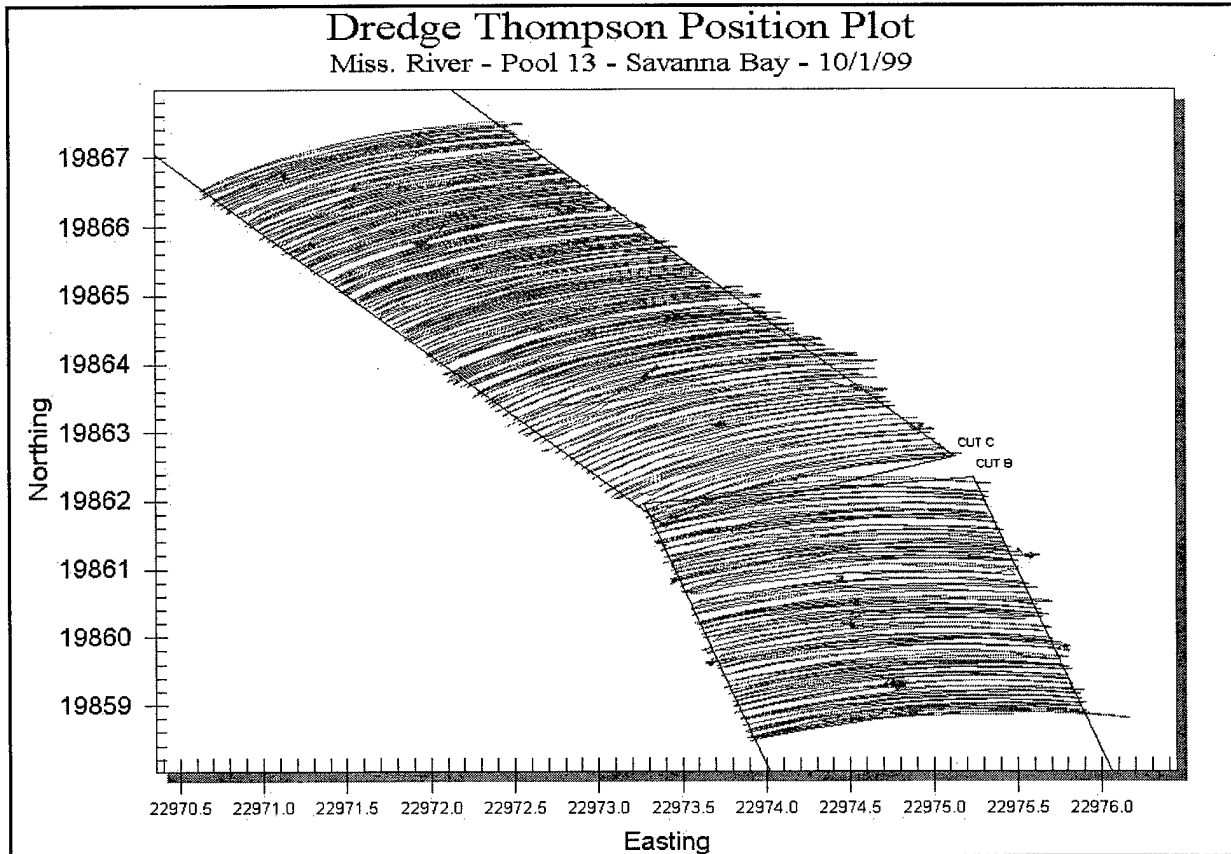

Figure 1. Time-history of cutterhead position

accurate results. Magnetic flowmeters are superior to Doppler-based flowmeters but cost considerably more. Density meters typically use a nuclear source and measure the attenuation of the nuclear particle flux through the pipe. They require a licensed technician to handle the source and documentation. Despite these drawbacks, most larger pipeline dredges have them.

Production meters can only measure production through the pipeline. Some production may occur from the transport of sediment dislodged during the dredging process, especially in fine sediments. When comparing production meter output to survey volumes, the best results are usually obtained in sands where the in situ density is well known.

Additional parameters can be measured to fully characterize the limiting factors affecting dredge performance. The most important of these are pump-related parameters, such as revolutions per minute, suction vacuum, and discharge pressures. Important for some projects are dislodgment-related parameters, such as cutter motor and swing winch loads. Furthermore, projects that require extensive use of booster pumps may need to monitor them as well.

Provide Trustworthy Facts. The increase in construction claims and litigation during the past decade emphasizes the need to document the facts that may be used as evidence in negotiation and litigation. Sanderson succinctly related this need in his presentation at the Texas A&M 1992 Dredging Engineering Short Course:

“The most important single lesson to be learned by both the Contractor’s project personnel and the Government inspector is the value of good documentation of the facts. Facts are evidence. Evidence is the essence of the negotiation and litigation process.

The job record must be accurate, complete and made clear to those who must rely upon it during attempts to settle disagreements at the job level and later in the courts. Good documentation is direct and does not contain emotional statements, and if opinions are stated they must be justified. Attempts to mislead or to falsify the record usually fails to achieve the purpose intended and is a very poor practice on either side. Good documentation is made as the events occur. Recollection of facts after the events is never as good as a contemporaneous record. A lawyer cannot be expected to get a good decision at the bargaining table or before the judge if the facts were not properly documented.

When the claim becomes an appeal of the CO (Contracting Officer) decision, the process of discovery begins in earnest and efforts to generate new evidence becomes a necessity for both sides. The documentation of the facts is then questioned by attorneys on both sides. The accuracy, truthfulness, and the appropriateness of the documentation becomes an issue. It is at this time that the adequacy and quality of the documentation becomes apparent. To find that the documentation which the CO relied upon in his decision is, in fact, faulty is the surest way to receive an adverse decision from the Board. Attorneys are trained to find flaws in the data and they capitalize on faulty information and missing facts that are pertinent to the dispute. The discovery process gives them ample opportunity to question all the documentation and to gather new data that may cast doubt on the official record. Documentation is easy to do at the time events are transpiring but faulty documentation is very difficult to correct or change after the facts are obscured...The record should be thoroughly, accurately and faithfully documented, and those at the upper levels of authority must constantly review and understand the significance of the daily documentation." (Sanderson 1992).

In summary, those contemporaneously-collected data which may be used in contract litigation must be scientifically sound, unbiased, and generally accepted as accurate.

Because the Corps’ dredging requires frequent interactions with other Federal and State agencies, the “facts” the Corps collects about dredging activities must be acceptable to those agencies. The necessity for these interactions also constrains the types of data to be collected, the methods of data collection, and analysis/reporting methods.

SI ASSISTANCE TO THE HUMAN INSPECTOR: Hopman (1986) suggested the SI concept as a way to eliminate the need to have Corps inspectors onboard dredges 24 hours a day. Clearly an automated monitoring system could not possibly collect all the different types of data (visual, verbal, etc.) needed to fulfill all of the inspection responsibilities. Therefore, the SI is not intended to totally replace Corps dredging inspectors. However, it will collect, analyze, and report the parameters that help Corps inspectors accomplish their mission more efficiently.

A major accomplishment of the HDPSI work unit was polling the Corps’ dredging community to identify the SI system functions that would best meet their needs. The personnel interviewed

included project managers, contract administrators, planners, estimators, dredging inspectors, and engineers. These interviews provided a wide range of perspectives concerning the applicability of the HPD Silent Inspector concept, and specific data needs for the interviewee's respective job responsibilities. Their replies reflected the differences between Districts in regard to: the types of dredges and dredging contracts they use, total volumes dredged, environmental considerations, history of contract claims, and inspector personnel levels. The Corps personnel who expressed a need for an HPD automated monitoring system identified the three specific objectives discussed earlier.

The dredge's performance relative to historical and theoretical limits is an important aspect of contract management, especially for contracts that reward increased performance. Data acquired by the SI system will be used to improve both the historical database of dredge performance and the tools for predicting dredge performance. Reports produced by the system will allow Corps dredging managers to compare current dredge performance to predicted and historical values. Because the SI will facilitate automatic incorporation of data and data products, records and progress reports will become more comprehensive and will be better tools for planners and contract administrators to use in planning and allocating resources for future work.

SYSTEM CHARACTERISTICS: The following section lists and discusses the specific attributes and capabilities that are desirable in the HPDSI. They are similar to those developed for the Silent Inspector hopper dredge system (Beeman 1990), but include modifications to account for a) the differing needs expressed by various Districts for HPD inspection, and b) the dredge's mechanical and operational differences.

Provide Standardized Information. Standardized data requirements along with standardized reporting formats are needed to maximize the usefulness of the HPDSI. For example, such standardization will:

- Make it easier for one District to use dredging histories from projects outside the District when estimating their own costs for new work.
- Allow contractors to move between Districts with the knowledge that they are properly equipped.
- Allow Districts to use standard or "guide" specifications when specifying information requirements in contract documents with the knowledge that the contractor dredge has the means to conform to the Corps' requirements.

An example of successful District cooperation to standardize inspection requirements is the safety regulations contained in Engineer Manual 385-1-1 (Headquarters, U.S. Army Corps of Engineers 1996).

Each District may have somewhat different information requirements, depending on such things as a) that District's specific business practices, b) the type of dredging to be conducted (confined disposal area, contaminated, etc.), and/or c) the type of dredging contract. Although the same requirements could be established across-the-board for all HPD's, the cost of the monitoring system "could quickly exceed the value of the dredge(s) which would not be a cost-effective solution"

(Beeman 1990). Another issue that must be evaluated is the impact of system cost on the issue of fair competition (unrestricted large business versus small business).

This work unit will facilitate the desired standardization by weighing the previously mentioned factors and suggesting a) the suite of data that meets most needs for contract administration, project budgeting, and cost estimating of future work, and b) the accuracy and precision required of the HPDSI.

Electronically Record Dredge Activities. Pertinent data should be automatically recorded by the HPDSI. Data to be recorded should be outputs from the sensors and should provide the system the ability to calculate and record dredging activities versus time and space.

Graphically Record Activities with Respect to Time and Space. The system should create graphic displays of both sensor outputs and dredge activities as functions of time and location. Some of these graphic plots should be predefined, and some should be user adaptable. All information should be available to export to other data presentation programs, such as Geographic Information Systems.

Automatically Create Dredging Reports. The system should automatically calculate and display daily, monthly, and job dredging activities in a manner acceptable for long-term archiving of the information. To take full advantage of the system, a complete plan for data retention and archiving will have to be implemented at a consistent nationwide level. This plan must differentiate between records kept for contract purposes, and records kept for project planning, budgeting, and cost estimating.

Allow System Flexibility and Expandability. The system adapted must be both flexible and expandable. It should be able to avoid technological obsolescence by incorporating new and improved technology as it is developed. The adopted system should be able to respond to each District's unique requirements without changing or increasing all systems to respond to the needs of one District. Therefore, the system must be designed so individual users can add on individual features without destroying the integrity or operation of the basic system. The requirements for the "minimum" standards for reporting will also be changed from time to time as conditions change in the industry and in the Corps of Engineers. The system should be able to accommodate those changes.

Provide for Data Neutrality. The information developed should be neutral. It represents neither "contractor" data nor "Corps" data, but rather will represent the facts of what happened aboard the dredge during the dredging cycle. Information manually entered into the system will be differentiated from that generated electronically. Likewise, data generated in the field or added in the office should be separated from the results of data analysis.

Provide for Personnel Neutrality. The goal of the system is to operate without increasing the number of people being used in dredge inspection and information archiving. Individual Districts should be free to choose whatever inspection system suits them best, based on local conditions and their responsibility for contract administration. Manning levels should not be dictated or imposed

by the system. The system should also not require extensive training that will fundamentally change the job description of the personnel presently performing inspector duties.

Provide for Equipment Neutrality. Because purchasing and managing property is a significant problem for Corps dredging managers, dredge contractors should provide the system hardware. The Specifications section below addresses how the contracting process can be used to ensure that the contractor-provided system hardware meets Corps' needs. The Corps' HPDSI software would then operate on the standard (neutral) hardware platform provided by the contractor.

Allow for Operational Checks. The system should provide a means of confirming accurate data inputs.

Permit Efficient Error Handling. When the system receives erroneous data, the system should not cease operation. If a system reset occurs, watch standers should receive an alert signal if at all possible.

Allow for Unattended Operation. After initial setup by an inspector, the system should operate unattended for up to 30 days. When the system goes offline (on purpose or from power loss), it should be able to save the setup values/commands and reboot itself automatically when re-energized.

Provide Adequate Data Security. Data recorded by the system should be tamper-proof. The system should allow only authorized personnel to enter setup data and should provide an audit trail for any later changes to recorded data.

SI COMPONENTS: The probable components of the HDPSI system are the Dredge Specific System, the Ship Server, and the Shore System. Their functions and interrelationships are discussed in the following section.

Dredge Specific System. Many pipeline dredges already have computer based data-acquisition and display systems, especially for positioning. These systems are called Dredge Specific Systems (DSS). A DSS is the contractor's system for quality control of the dredging project. The DSS collects data from various sensors, and then formats and displays these data to the dredge crew. DSS systems can be developed in-house by dredging contractors, or they can be purchased on a turnkey basis from instrumentation subcontractors.

Ship Server. As part of the SI design, the DSS sends out data to another computer, the Ship Server, that performs tasks for the Corps. These tasks include data archiving, report generation, and automated data quality assurance. Corps inspectors also use the Ship Server for their daily reporting and other project documentation needs.

Shore System. A shore-based system is also part of the SI design. It provides the same functionality as the Ship Server, but has greater data storage and data reporting capabilities. Data (including daily reports) are taken from dredges either by data link or magnetic media and are archived on the Shore System.

SPECIFICATIONS: Contract specifications have been developed to describe a process by which the Corps and contractors can cooperate to implement the SI and perform their quality assurance and quality control duties. The specifications: a) implement the SI design, b) meet the requirements previously defined, and c) work within existing Corps contracting mechanisms. A Process Action Team consisting of Corps and Dredging Industry members is reviewing these specifications. Instrumentation vendors are providing input as well. Whenever appropriate, the specifications will be revised to assure Corps SI users that everyone's concerns have been addressed. Pertinent highlights of these specifications are summarized in the following sections.

Data Transfer. The National Marine Electronics Association 0183 data format will define how the DSS and Ship Server should talk to each other. This standard's proprietary data sentence structure is used to define custom dredging data strings for related data and for each dredge type. This standardization can accommodate all of the previously mentioned requirements and can easily be extended to handle unforeseen data-reporting requirements.

Data-reporting Performance. For each dredge type in the specifications, an overall performance clause tries to insure that the contractor's DSS not only meets the letter of the specifications but also works as intended.

Dredge Plant Instrumentation Plan (DPIP). The contract specifications require the contractor to submit a DPIP, which contains the extensive information about the dredge that the Corps needs to perform its quality assurance role. Typical information in the DPIP includes the dredge dimensions, sensor descriptions, sensor calibrations, and quality control procedures.

Inspector Tests. The specifications also detail some of the quality assurance tests that the inspectors may conduct as part of their duties. This information informs the contractor of possible occurrences that may detract from his productive working time. For example, to check the dredge's production meter, the inspector may request the dredge to pump water for a time.

SI IMPLEMENTATION: With the cooperation of the St. Paul District, the dredge *William A. Thompson* was used for an example implementation of the Silent Inspector. The *Thompson* is a 6.70-m (22-in.) Corps pipeline dredge operated by the St. Paul District (Figure 2). It works for the Districts on the Upper Mississippi River. Because the *Thompson* is Corps-owned, contractual problems could be avoided while any potential problems with the system were worked out. The following section discusses how the SI system was implemented on the *Thompson* and presents some early results.

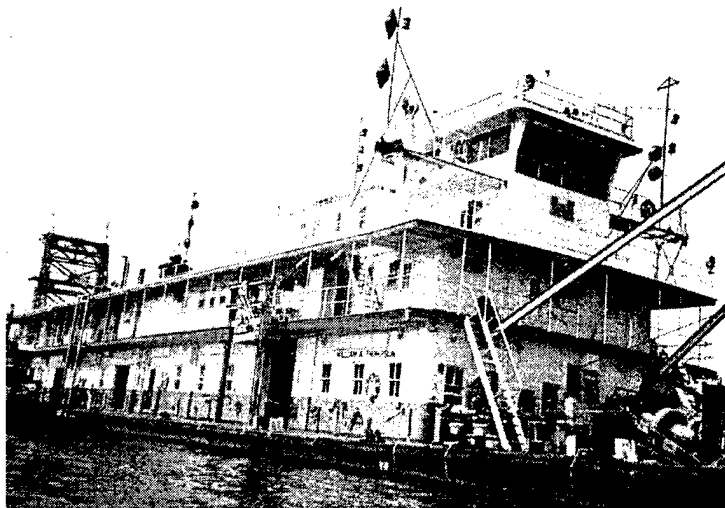

Figure 2. The dredge *William A. Thompson*

The Thompson SI System. The *Thompson* uses the DREDGEPAK software made by Coastal Oceanographics. This software was modified by Coastal Oceanographics starting in August 1998 to serve as a SI DSS. Additional data were collected during the 1999 dredging season and more will be collected for the 2000 dredging season. Most of the needed hardware was already available and installed on the dredge. The Ship Server (a 100 MHz Pentium laptop computer) was provided by the SI work unit.

Thompson Data Acquisition. As stated earlier, primary data requirements are the corrected three-dimensional position of the dredge cutterhead, and an indicator of production. As shown in Figure 3, the *Thompson* measures horizontal position with a differential Global Positioning System (GPS). The GPS antenna is located on the pilohouse, so the heading angle from the gyro is used to translate the antenna position to the horizontal cutterhead position. The vertical cutterhead position is measured with an angle sensor located on the dredge ladder. This position is corrected using the river-stage. Although the SI specifications state that these positions should be reported to the Class 1 survey accuracy standard of one-half foot, this has not yet been verified on the *Thompson*.

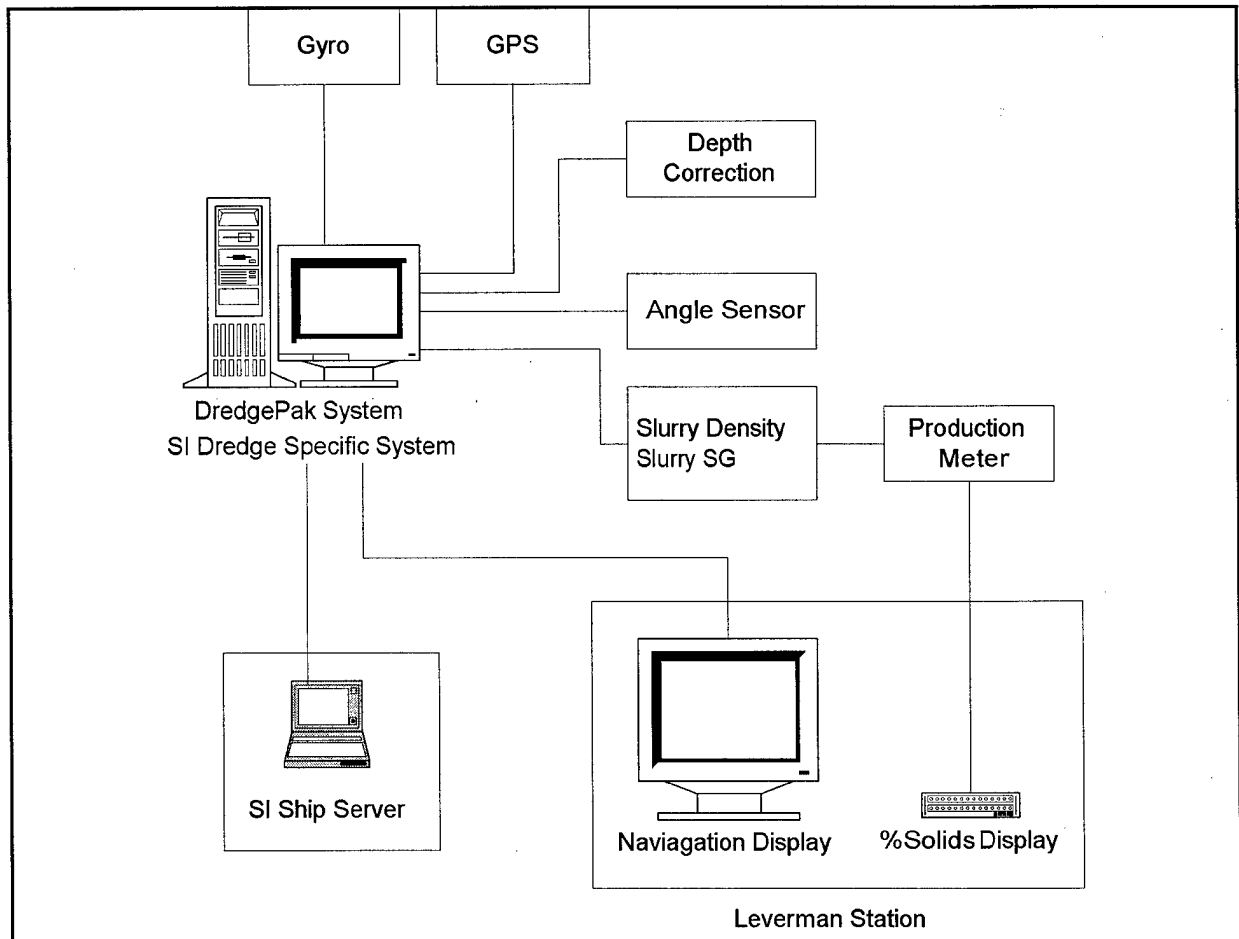

Figure 3. Instrumentation layout on dredge *Thompson*

The production meter on the *Thompson* consists of a Texas nuclear densimeter and Doppler flowmeter. Outputs from these instruments are connected to a display on the bridge and to the DSS. The SI work unit provided a serial interface module for the production meter to allow it to send digital density and flow data to the DSS. The DSS computer sends out data to the Ship Server over another serial port, but it also stores the data within the DSS.

Data Analysis and Reporting. The raw data are available for visual inspection (Figure 4) and quality assurance purposes. Manually reviewing the raw data is too time-consuming for inspectors to perform on a regular basis, however.

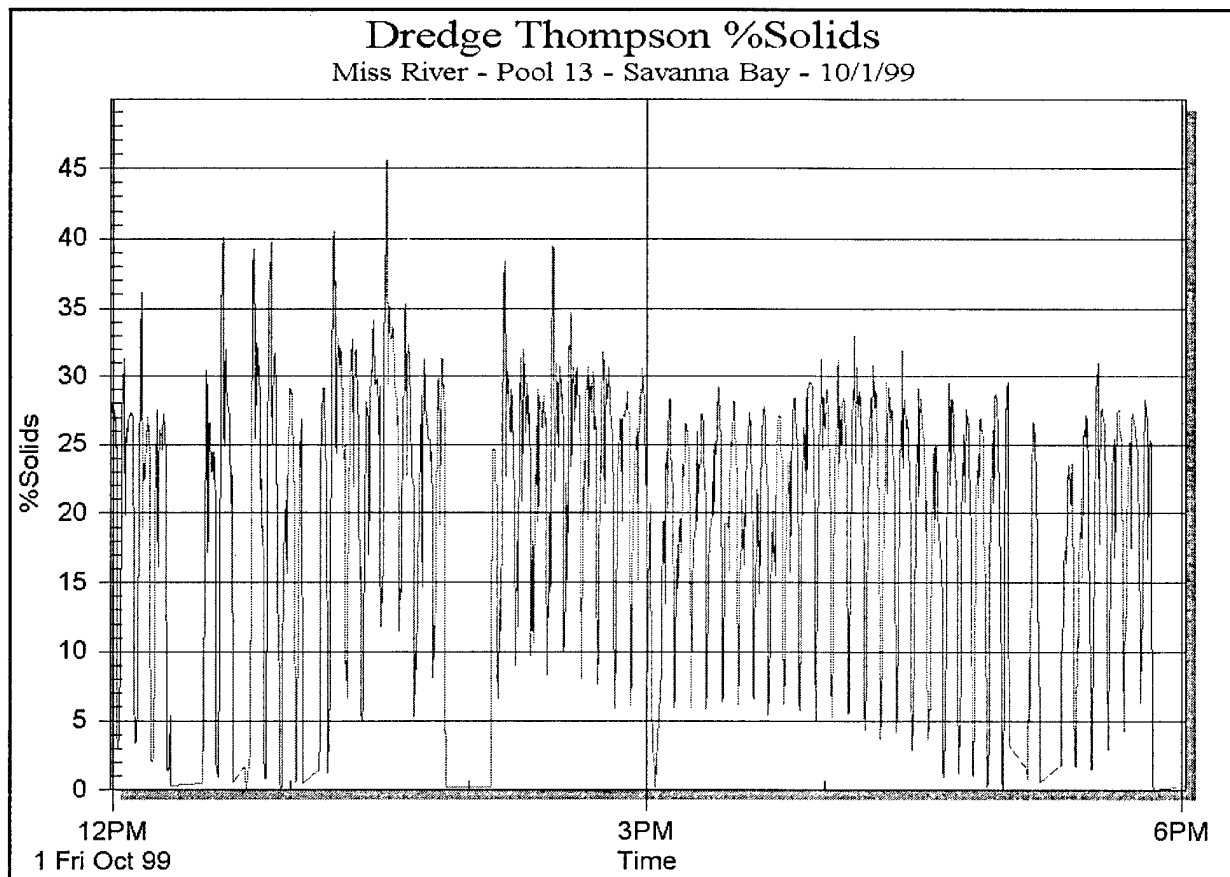

Figure 4. Percent solids by weight versus time

The SI can produce some of the summary data that are now reported by manual methods. Table 1 shows a comparison between some manual daily report data from the dredge *Thompson* and the SI computed ones. These data were taken between September 29, 1999 and October 4, 1999 at Savanna Bay (River mile 538.5, Rock Island District) on the Mississippi River. The *Thompson's* cubic yards per hour are derived from survey data, the effective time from the daily logs and the distance advanced from the DSS. The SI uses the observed pumping time to compute the effective time, the cubic yards per hour are computed from the production meter, and the distance advanced is computed from the DSS-provided horizontal position data.

Table 1 need title			
Description	SI Measured	Thompson Daily Report	Percent Difference
Effective Time ¹	81.0 hours	81.35 hours	0.43
Distance advance on 10/1/1999	285.59 m (937 ft)	286.51 m (940 ft)	0.32
Cu m (cu yd)/hr	831.83 cu m (1008 cu yd) ²	831.82 cu m (1088 cu yd)	7.3
¹ Over entire reporting interval. ² Using an in situ density of 1.9 cu cm over entire reporting interval.			

SUMMARY AND DISCUSSION: Good daily documentation of a dredging project is essential. The SI can help document the position and production state of the dredge. However, some aspects of the project, such as pipeline length and terminal elevation are best entered manually. The SI facilitates daily reporting by producing daily reports based on recorded data and allowing the electronic filing of existing standard dredging forms (such as Engineering Form 4267). Each Ship Server serves as an Internet gateway, which allows the transfer of these reports to the shore-based SI via standard internet protocols.

Using the actual performance data provided by the Thompson's DSS, the SI can produce some of the numbers as shown in Table 1, commonly used by dredging inspectors and managers. Although dredge surveys provide the final evaluation of dredge production, the SI can provide production estimates between surveys to help identify potential problems earlier. Also, the detailed production data from the HPDSI can help to assure that the contractor is operating the dredge in the manner consistent with District wishes. For example, it may be desirable to maximize the solids concentration of the dredge discharge to reduce the amount of effluent from a confined disposal facility.

The positioning data provide insight to dredging contract administrators and estimators. These data help confirm estimates of dredge swing rate and width. Although it is usually not in the interest of the contractor to perform any dredging work outside of the dredge prism, and contractors now have the tools to accurately position themselves, it is still necessary to assure that the contractor is working only in designated areas. Overdredging is undesirable especially for jobs where the cost to dispose of the material is high. The HPDSI provides tools to allow inspectors to review the dredge data back in the office or on the dredge independent of the DSS software (if the DSS software supports this playback capability if it can be used as well). Additionally, the detailed SI data can be used to directly compute the swing and cycle efficiency, which are useful to dredge estimators to compute the theoretical production capability of the dredge.

The SI provides a means to manage historical data as well. The SI database can contain the daily reports, raw and computed data, and project and contract tracking information. The SI database forms the backbone of the Ship Server and shore-based systems. Future technical notes will cover these capabilities and more advanced and in-depth dredge data analysis, including additional examples from the HPDSI on the *Thompson*.

POINTS OF CONTACT: For additional information on the Silent Inspector System, contact the author, Mr. James Rosati (601-624-2022, rosatij@wes.army.mil) or the Program Manager of the Dredging Operations and Environmental Research Program, Dr. Robert M. Engler (601-634-3624, englerr@wes.army.mil). This technical note should be cited as follows:

Rosati, J. (2000). "Silent inspector for hydraulic pipeline dredges," *DOER Technical Notes Collection* (ERDC TN-DOER-I4), U.S. Army Engineer Research and Development Center, Vicksburg, MS. www.wes.army.mil/el/dots/doer

REFERENCES

- Headquarters, U.S. Army Corps of Engineers. (1996). "Safety and health requirements manual," Engineer Manual 385-1-1, Washington, DC.
- Hopman, R. J., (1986). "The Silent Inspector," *XIth World Dredging Congress 1986, Brighton, CEDA, Delft, The Netherlands*, 4-7 March, 1986.
- Pankow, V. R. (1990). "Dredge production meter survey," Dredging Research Technical Notes DRP-4-05, U.S. Army Engineer Waterways Experiment Station, Vicksburg, MS.
- Ogden Beeman & Associates, Inc. (1990). "Needs assessment for a dredge automated inspection system," Contract Report for Department of the Army, Dredging Research Program, Waterways Experiment Laboratory, Vicksburg, MS.
- Rosati, J., and Welp, T. (1999). "Case studies: Monitoring pipeline dredges," *DOER Technical Notes Collection* (TN DOER-I1), U.S. Army Research and Development Center, Vicksburg, MS. www.wes.army.mil/el/dots/doer
- Sanderson, W. H. (1992). "Government contract disputes," 1992 Dredging Engineering Short Course, Texas A&M University, Volume II.

NOTE: *The contents of this technical note are not to be used for advertising, publication, or promotional purposes. Citation of trade names does not constitute an official endorsement or approval of the use of such products.*