



Fabrication of Novel Bumper and Skirt Components for a Ground Vehicle

by William A. Spurgeon
and David J. Thomas

ARL-TR-2327

September 2000

Approved for public release; distribution is unlimited.

20001115 136

The findings in this report are not to be construed as an official Department of the Army position unless so designated by other authorized documents.

Citation of manufacturer's or trade names does not constitute an official endorsement or approval of the use thereof.

Destroy this report when it is no longer needed. Do not return it to the originator.

Army Research Laboratory

Aberdeen Proving Ground, MD 21005-5069

ARL-TR-2327

September 2000

Fabrication of Novel Bumper and Skirt Components for a Ground Vehicle

William A. Spurgeon

Weapons and Materials Research Directorate, ARL

David J. Thomas

U.S. Army Tank-Automotive Research, Development,
and Engineering Center, Warren, MI

Approved for public release; distribution is unlimited.

Abstract

This report discusses the materials selection for and fabrication of novel “bumper” and skirt panels for an experimental ground vehicle improvement project. These components were fabricated from E-glass reinforced polyurethane resin so that they would have a unique combination of rigidity and flexibility required for successful field use. Alternative components for future consideration are discussed, and some initial work on adhesive bonding of polyurethane matrix composites is presented.

Acknowledgments

The author would like to thank David Hansen of the U.S. Army Tank-Automotive Research, Development, and Engineering Center (TARDEC) for suggesting and financially supporting this effort. Craig Hughes of the Keewenaw Research Center, Houghton, MI, provided the drawings in Figures 1 and 2. Michael Leadore of the U.S. Army Research Laboratory (ARL) provided Figure 10. Eric Fine, Michael Poot, and Scott Vandry of the University of Delaware, and Christopher Klug of the University of Maryland each helped with the parts fabrication, as did Melissa Klusewicz and, especially, John Brown of ARL. Alan Teets of ARL assisted with the mechanical testing. Critical readings by Peter G. Dehmer, Dana M. Granville, and Robert Lieb significantly improved this report. Everyone's help was critical in successfully completing this project and is gratefully acknowledged.

INTENTIONALLY LEFT BLANK.

Table of Contents

	<u>Page</u>
Acknowledgments	iii
List of Figures	vii
List of Tables	ix
1. Introduction	1
2. Materials Selection	1
2.1 Matrix Polymer	1
2.2 Glass Reinforcement	4
3. Composite Material Mechanical Properties	7
4. Composite Fabrication	7
4.1 General Considerations	7
4.2 Flat Panel Fabrication.....	8
4.3 Skirt Panel Fabrication	10
4.4 Bumper Panel Fabrication	15
5. Possible Design Alternatives	21
5.1 Skirt Panels	21
5.2 Bumper Panels	21
6. Conclusions	25
7. References	27
Appendix: Adhesive Bonding Adiprene Matrix Composites: Preliminary Results	29
Distribution List	35
Report Documentation Page	41

INTENTIONALLY LEFT BLANK.

List of Figures

<u>Figure</u>		<u>Page</u>
1.	A Drawing of the Proposed Skirt Panel Required for the Project	2
2.	A Drawing of the Proposed Bumper Panels Required for the Project	3
3.	The 24-oz, 5 × 4 Woven Roving Fabric and the 15-oz, 2 × 2 Twill Weave Fabric	6
4.	A Typical Flexure Displacement vs. Applied Load Curve for an Adiprene Composite Sample.....	9
5.	The “V” Mold Used to Fabricate the Skirt Panels	11
6.	A Skirt Panel Prior to Final Trimming.....	13
7.	A Skirt Panel After Trimming to Size	14
8.	The Left-Handed Box Mold Used to Fabricate Bumper Panel Components in the Attempt at a Full-Up Bumper Panel.....	16
9.	The Cross and Crown Cutting Patterns.....	17
10.	The 10-Ply Part Fabricated on the Male Mold.....	19
11.	Two Initial Subassemblies for a Bumper	20
12.	The Open Box Subassembly, Oversized Top, and Four Special L Brackets Ready for Final Assembly	22
13.	Bonding the Top to the Rest of the Bumper.....	23
14.	Completed Left and Right Bumpers.....	24

INTENTIONALLY LEFT BLANK.

List of Tables

<u>Table</u>	<u>Page</u>
1. Solvent and Water Stability Data for Adiprene L-100 With Catur 21	5
2. Tensile Strengths (ksi) for E-Glass-Adiprene Composites	7
3. Flexure Strength and Modulus Data for E-Glass-Adiprene Composites	8
4. The Sequence of Release and Bleeder/Breather Fabrics Used in the Composite Fabrication Process	10
A-1. Adhesive Bond Strengths for Glass-Reinforced Adiprene Matrix Composite to Itself	31
A-2. Adhesive Bond Strengths for Glass-Reinforced Adiprene Matrix Composite to Other Materials	33

INTENTIONALLY LEFT BLANK.

1. Introduction

In support of an experimental Army ground vehicle improvement program, the U.S. Army Research Laboratory (ARL) composite development team was asked to fabricate four new composite vehicle components (shown as conceptual drawings in Figures 1 and 2). The two "bumper" panels were selected to fill out the front corners of the vehicle. The other two components are L-shaped skirt panels that get bolted to the bumper panels. These components were fabricated from glass-reinforced polyurethane resin. Skirt panels made from this composite material are stiff enough not to wobble or sway while the vehicle is being driven, but retain the ability to flex when necessary. The composite is also appropriate for the bumper panels, which need to be able to compress or flex on impact and return to their original shape without breaking. The mounting arrangements for the bumpers to the vehicle and the skirt panels to the bumpers must also be able to sustain the impact. The designs considered in this report are a first attempt at the necessary components.

This report discusses the materials selection for the project, mechanical properties of the composite materials, and component fabrication. The results of the field evaluation of the components were satisfactory and will be reported separately. Section 5 discusses alternative components for future consideration that could work as well or better and would be easier to fabricate. Some work on the adhesive bonding of the polyurethane matrix composites was also needed to complete the project and is discussed in the appendix.

2. Materials Selection

2.1 Matrix Polymer. The matrix polymer resin selected for this project was Adiprene L-100 cured with Catur 21. Both the resin and curing agent were obtained from the Uniroyal Chemical Company.* Dr. Roger Crane of the Naval Surface Warfare Center (NSWC),

* Uniroyal Chemical Company, Inc., World Headquarters, Middlebury, CT 06749.

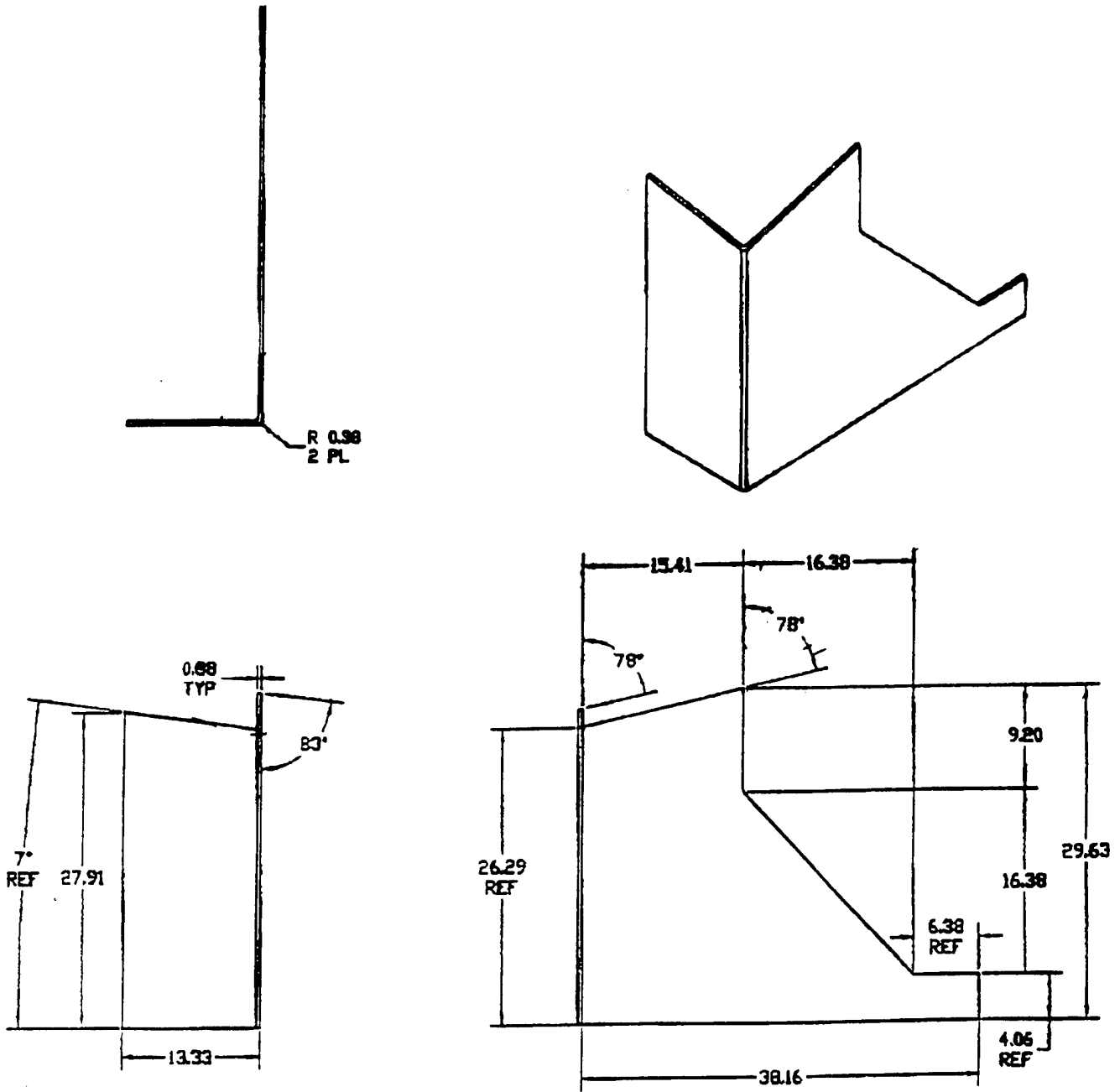

Figure 1. A Drawing of the Proposed Skirt Panel Required for the Project.

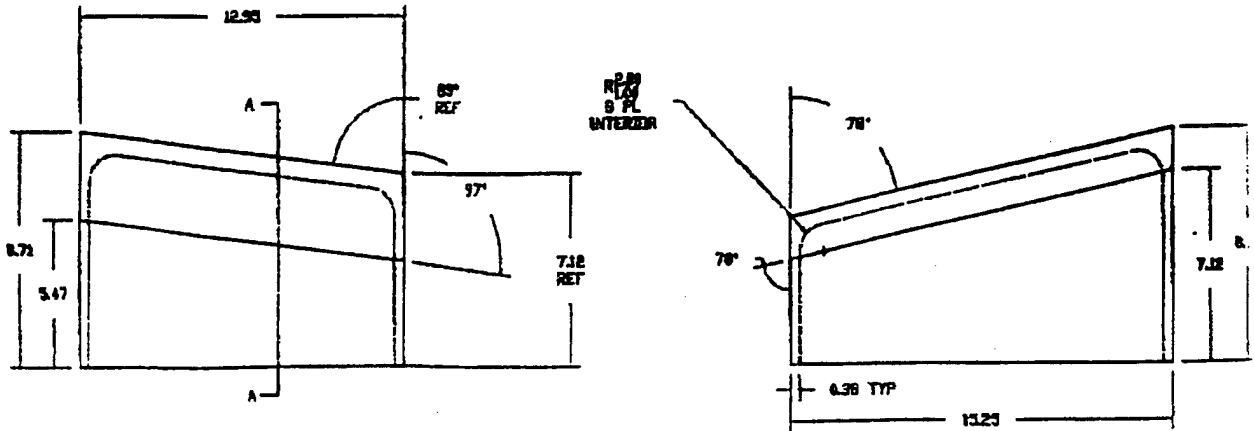
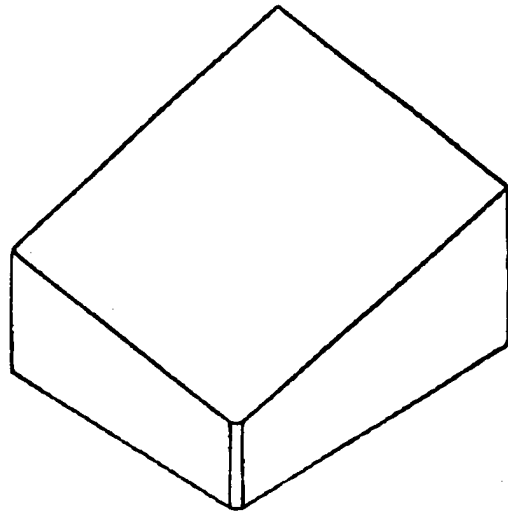
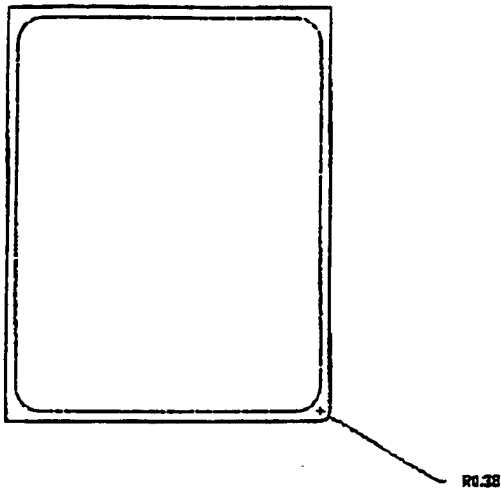

Figure 2. A Drawing of the Proposed Bumper Panels Required for the Project (Mirror Image Versions of Both the Skirt and Bumper Panels Were Also Needed).

Carderock Division, Bethesda, MD, provided the original recommendation to use this resin based on his extensive experience with such resins.

In previous ARL work [1], this polyether-based polyurethane resin exhibited a hardness of Shore-A 85, which is somewhat harder than an automobile tire (Shore-A 75) and softer than a typewriter roller (Shore-A 90). Nearly all of the toluene-diisocyanate it contains is chemically bound (as opposed to free), which makes it relatively safe to handle. Its most desirable feature is that it has a long working life at temperatures below 150 °F, and it cures quickly at temperatures above 212 °F. Its glass transition temperature is below the -60 °F limit of the differential scanning calorimeter used for this test. The resin had been used in other ARL projects that required a semi-flexible composite. Its selection followed an extensive search for appropriate thermoset polyurethane resins through vendor contacts and in-house tests. Its cost depends on the quantity purchased, but it is under \$5/lb when purchased in 5-gal containers (convenient for laboratory work) that weigh approximately 45 lb.

Solvent and water stability tests were run as part of a previous project; the results are summarized in Table 1. The hydrolytic stability of the resin was not as good as might be desired, but was deemed suitable to use for this project. A strong point in its favor is that the Navy uses the resin on underwater control surfaces [2]. In Navy tests, it exhibited no degradation in strength after a 2-year soak in 75 °F water, although it does degrade at higher temperatures as indicated in Table 1.

2.2. Glass Reinforcement. Standard E-glass was selected for a reinforcement fiber since the application did not require the higher-strength, more expensive S-2 glass. The tensile strength of the E-glass is not dramatically lower than that of S-2 glass (500–550 vs. 665–700 ksi). It is much less expensive than S-2 glass (\$1.29 vs. ~ \$7/lb).^{*} Another advantage is that its composites can generally be machined with standard metal cutting tools, whereas S-2 glass composites usually require diamond-tipped tools.

^{*} Owens-Corning Brochure. "Advanced Materials." Pub. No. 1-PL-16052-D, Owens-Corning World Headquarters, One Owens-Corning Parkway, Toledo, OH 43659, September 1996.

Table 1. Solvent and Water Stability Data for Adiprene L-100 With Catur 21

Test Performed	Material	Volume Swell (%)	Tensile Retained (%)	Strength for 200% Elongation Retained (%)	Elongations Retained (%)
Immersion in Fuel-B 70/30 150-Octane/Toluene for 7 Days at RT ^a	Adiprene L-100 With Catur 21	18.12	51.77	78.43	76.68
Immersion in JP-8 ST Reference Fuel for 7 Days at RT	Adiprene L-100 With Catur 21	13.19	55.49	79.99	76.68
Immersion in Hydraulic Fluid for 7 Days at RT	Adiprene L-100 With Catur 21	3.11	75.72	93.66	87.33
Immersion in Water for 14 Days at 160 °F	Adiprene L-100 With Catur 21	27.52	33.26	39.87	105.43

^a Room temperature

Two glass fabric styles were used which are shown in Figure 3. The first was a relatively stiff 5 × 4, 24-oz woven roving that contributed about 30 mil per ply to the composites made in this project. This fabric was made from Owens-Corning's E-glass roving and was woven by Owens-Corning Fabrics.* It had an Owens-Corning Type 111 epoxy-polyester-vinylester compatible sizing. The other fabric was a very flexible 15-oz, 2 × 2 twill weave that contributed about 15 mil per ply to composites. It was obtained from Fabric Development, Inc.,[†] and is made from PPG E-glass.[‡] This fabric has PPG-type 2002 sizing that is epoxy, polyester, and cyanate-ester compatible.

* Owens-Corning Fabrics, 1851 Seguin Road, New Braunfels, TX 78130.

[†] Fabric Development Inc., 1217 Mill Street, Quakertown, PA 18951.

[‡] Pittsburgh Paint and Glass, 1 PPG Place, Pittsburgh, PA 15272.

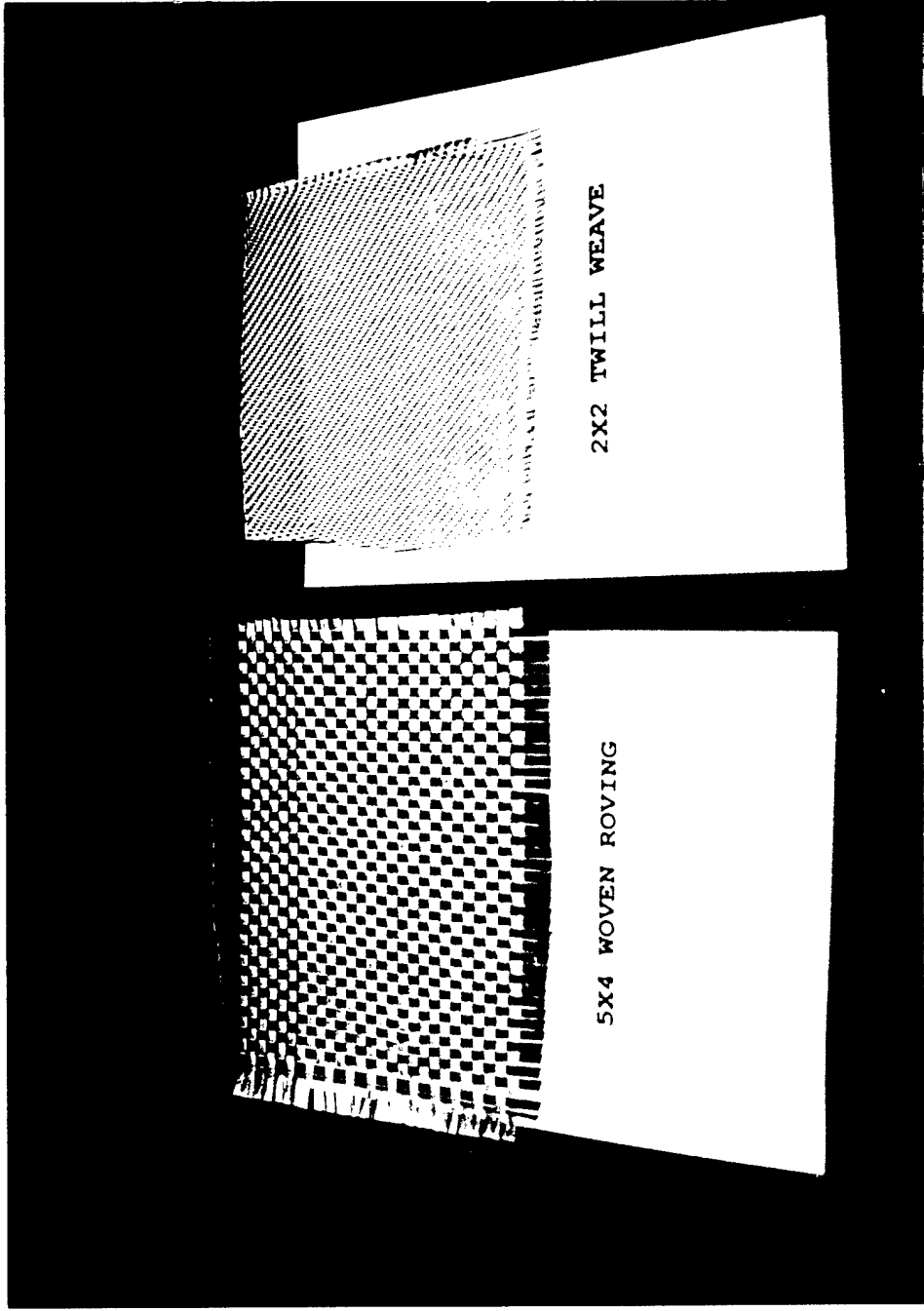

Figure 3. The 24-oz, 5 x 4 Woven Roving Fabric (Left) and the 15-oz, 2 x 2 Twill Weave Fabric (Right).

3. Composite Material Mechanical Properties

The mechanical properties of the E-glass-Adiprene composites have not been previously measured. The tensile strengths were measured per the American Society for Testing and Materials (ASTM) standard-D638 [3] for both types of fabric. Dumbbell-shaped samples were stamped out using a rubber cutting die. Two sets of samples were prepared: one with the sample axis along both the warp direction (the long direction of the roll), and the other with the sample axis in the orthogonal fill direction. The test results are presented in Table 2. It was expected that the test results for the two fabric styles would be quite different.

Table 2. Tensile Strengths (ksi) for E-Glass-Adiprene Composites

Tensile Strength		
Style	5 × 4 Woven Roving	2 × 2 Twill Weave
Warp	30.2 ± 1.3	18.6 ± 0.9
Fill	28.7 ± 1.1	16.3 ± 1.3

The apparent flexure strength and modulus of the composites were also measured per ASTM D790-96A [4]. These results are presented in Table 3. The samples for this test were stamped out of a flat sheet of material using a die 1 in wide × 6 in long. The apparent flexure strength was considered the maximum load the samples will support in the flexure test. The samples do not actually break; rather, they continue to bend as the test instrument tries to increase the load. A typical flexure displacement vs. applied load curve is shown in Figure 4. The samples return to their original shape when the load is removed.

4. Composite Fabrication

4.1. General Considerations. All Adiprene composite fabrication was done by hand using wet layup techniques. This was done to make a composite that was somewhat resin rich for flexibility and, also, for convenience because of the small number of parts needed. A new

Table 3. Flexure Strength and Modulus Data for E-Glass-Adiprene Composites

Fabric Style	Flexure Strength (ksi)	Flexure Modulus (msi)
Twill Warp	5.82 ± 0.65	1.07 ± 0.18
Twill Fill	5.89 ± 0.33	1.01 ± 0.13
Roving Warp	7.05 ± 0.28	1.48 ± 0.07
Roving Fill	7.23 ± 0.63	1.29 ± 0.09

vacuum-assisted resin transfer molding (VARTM) technique known as “Vmin” has been developed at ARL for fabricating composites with low-fiber volume percentages [5]. If more parts were needed, this would have been the fabrication method of choice. For large volume production, a regular resin transfer molding process might be the preferred fabrication method. In processing the composite parts, it was necessary to draw excess resin through the top and bottom surfaces of the part rather than just from the sides. To effect this, the stack of release films and breather fabrics shown in Table 4 was employed. It was absolutely necessary to use this arrangement to obtain a part free of objectionably large voids.

The Adiprene resin was preheated to 150 °F prior to being weighed out. One hundred and five percent by weight of the stoichiometric quantity of room temperature Catur 21 was then weighed out and thoroughly mixed with the Adiprene. One percent (by weight) of graphite powder (Fischer Grade 38*) was added to improve the ultraviolet (UV) stability of the polymer by making it black. In actual use, the parts would be painted or otherwise covered and thus protected from UV radiation.

4.2 Flat Panel Fabrication. Flat panel layups using the woven roving fabric were done on a heat table warmed to 140 °F, to ensure that the viscosity of the mixed resin would remain low. The resin will not cure below 212 °F, although it will hydrolyze and harden slowly in moist air. After vacuum bagging, the parts were heated to 165 °F and held for 1 hr, heated quickly to

* Fischer Scientific, 711 Forbes Avenue, Pittsburgh, PA 15219-4785.

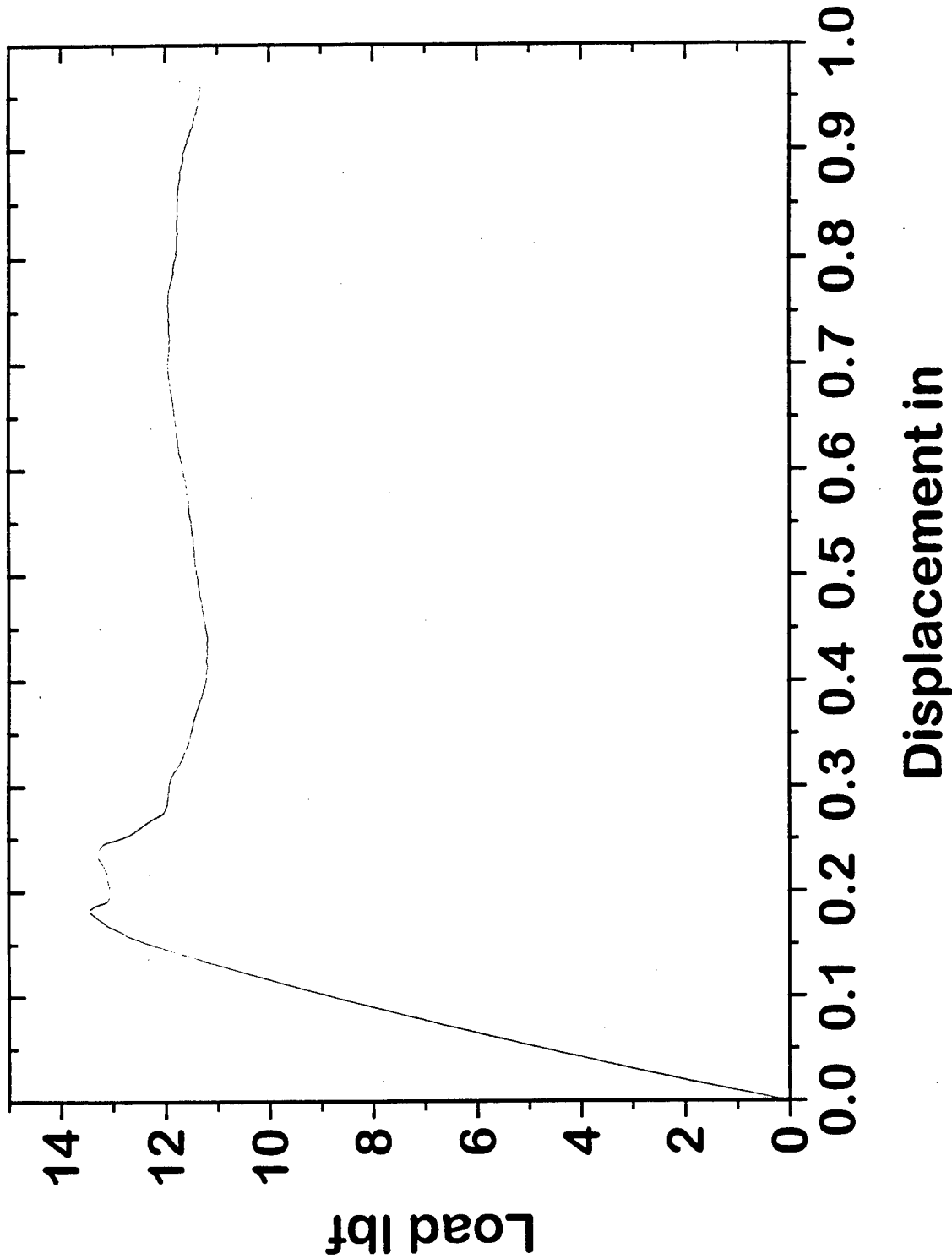

Figure 4. A Typical Flexure Displacement vs. Applied Load Curve for an Adiprene Composite Sample.

Table 4. The Sequence of Release and Bleeder/Breather Fabrics Used in the Composite Fabrication Process

Capran Vacuum Bag ^a
10-oz Spun Polyester Breather Fabric ^b
1/4-in Aluminum Caul Plate or Capran Sheet ^a
Nonporous Teflon-Coated Glass Release Film ^c
A8888 Green Porous Release Fabric ^d
4-oz Spun Polyester Breather Fabric ^c
A8888 Green Porous Release Fabric ^d (2 Plies)
Porous Teflon-Coated Glass Release Film ^c
Fabric Stack
Porous Teflon-Coated Glass Release Film ^f
4-oz Spun Polyester Breather Fabric ^c
Porous Teflon-Coated Glass Release Film ^c
Mold Release Caul Plate or Hot Table

Note: All materials were obtained from Northern Fiberglass Sales, Inc., P.O. Box 2010, Hampton, NH 03843-5098.

^a Capran 512, 0.002 in thick.

^b Part No. RC-A3000-10, 10-oz nonwoven polyester bleeder/breather.

^c Richmond 200TFNP release fabric.

^d Richmond A8888 open-weave polyamide release fabric.

^e Part No. RC-A3000-4, 4-oz nonwoven polyester bleeder/breather.

^f Richmond 200 TFP release fabric.

185 °F for 30 min, then heated rapidly to 250 °F and held for 90 min. This curing cycle was also used for the molded parts. The cure cycle allowed time for the viscous resin to flow and better wet-out the part, and for volatile materials to be removed from the part. Two 34-in × 50-in panels of flat stock and several smaller panels were made without incident in this manner.

4.3 Skirt Panel Fabrication. A V-shaped 0.5-in thick aluminum mold, 48 in on each side and 48 in wide, was used to fabricate the L-shaped skirt panels. The prepared mold, with the bottom three layers of the stack of release and breather fabrics in place, is shown in Figure 5. A 0.38-in radius was built into the mold at the joint. The side brackets hold the large sides of the mold at a 90° angle. They were generally removed during the layup process, then replaced after

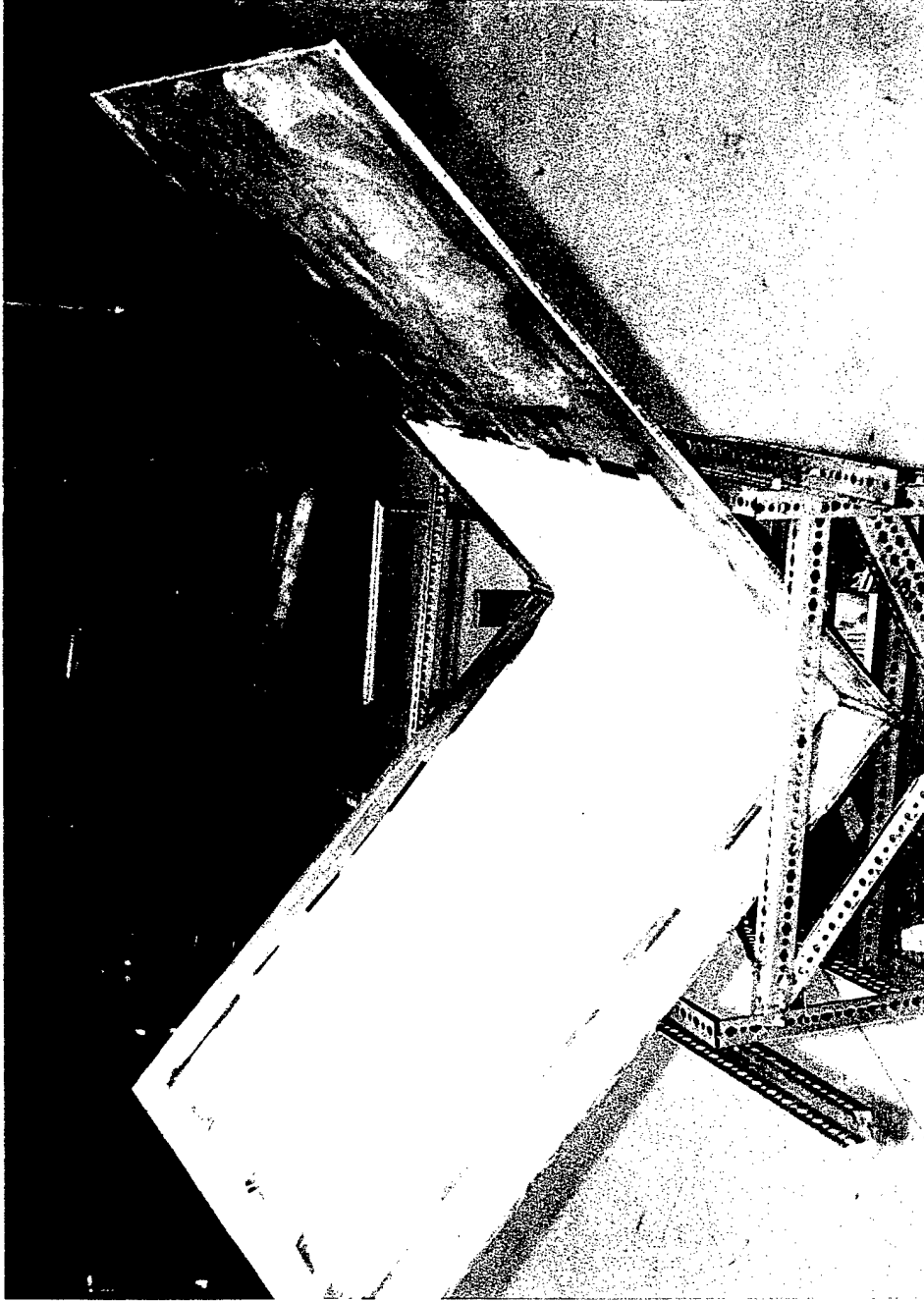

Figure 5. The "V" Mold Used to Fabricate the Skirt Panels.

bagging. The mold was preheated to 150 °F in a large oven prior to the layup process. Most of the skirt was fabricated using only eight plies of the woven roving fabric, which resulted in a thickness of about 0.23 in. Four additional plies of the woven roving were added to the portion of the skirt that would be attached to the bumper, resulting in a total thickness in this area of about 0.35 in, which was required to stiffen and strengthen this part of the skirt.

The woven roving fabric did not conform well to the 0.38-in radius of the mold. As a consequence, the radius on the outside of the skirt panel was closer to 0.75 in. This would not present a problem in using the skirt; however, the inside of the skirt panel had a much smaller radius. This, too, would not present a problem as long as the bumper panel was made to fit to the smaller radius. The main problem was that excess resin from the layup process tended to sink to the bottom of the mold where it partially filled the inner radius of the part. An extra 6-in-wide strip of 4-oz breather fabric placed in this area did not soak up all of the excess. The excess resin that remained after curing was either cut away with sharp knives or sanded away with a disk sander. The excess could have been left in place, except for the portion that joins the bumper.

Three parts were made using this mold. In the first, the mold was set with one edge flat against the worktable. This arrangement allowed several plies to slip down during the vacuum bagging operation. These slipped plies caused a wrinkle in the fabrics in the joint, and consequently, a rejected part. For subsequent parts, the mold was placed in a cradle, with the radiused joint at the bottom and both sides sloping upward. A second part came out very well. On the third attempt, one of the side braces was left off and the mold slipped away from a 90° angle by about 7°. This part was still acceptable since it could be pushed into shape very easily. All three parts were made with the fill direction of the fabric vertical in the finished part. The fabric was only 50 in wide, and fabricating the part in this manner allowed the most economical use of the fabric.

The molded skirt panel was trimmed to the desired size and shape using an ordinary saber saw with a steel blade. A skirt panel prior to trimming is shown in Figure 6, and a finished panel is shown in Figure 7. Each finished panel weighed 14.8 lb.

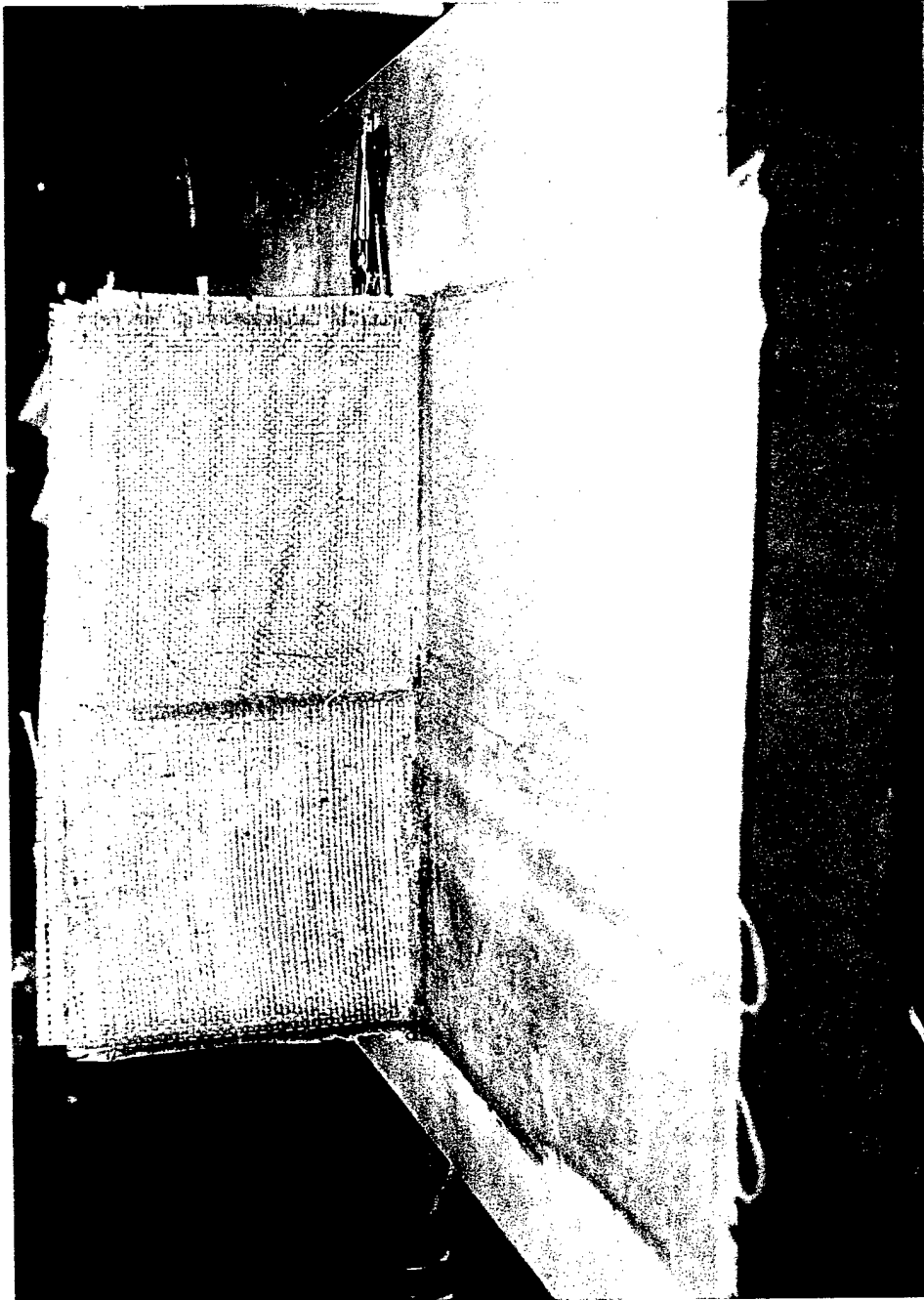

Figure 6. A Skirt Panel Prior to Final Trimming.

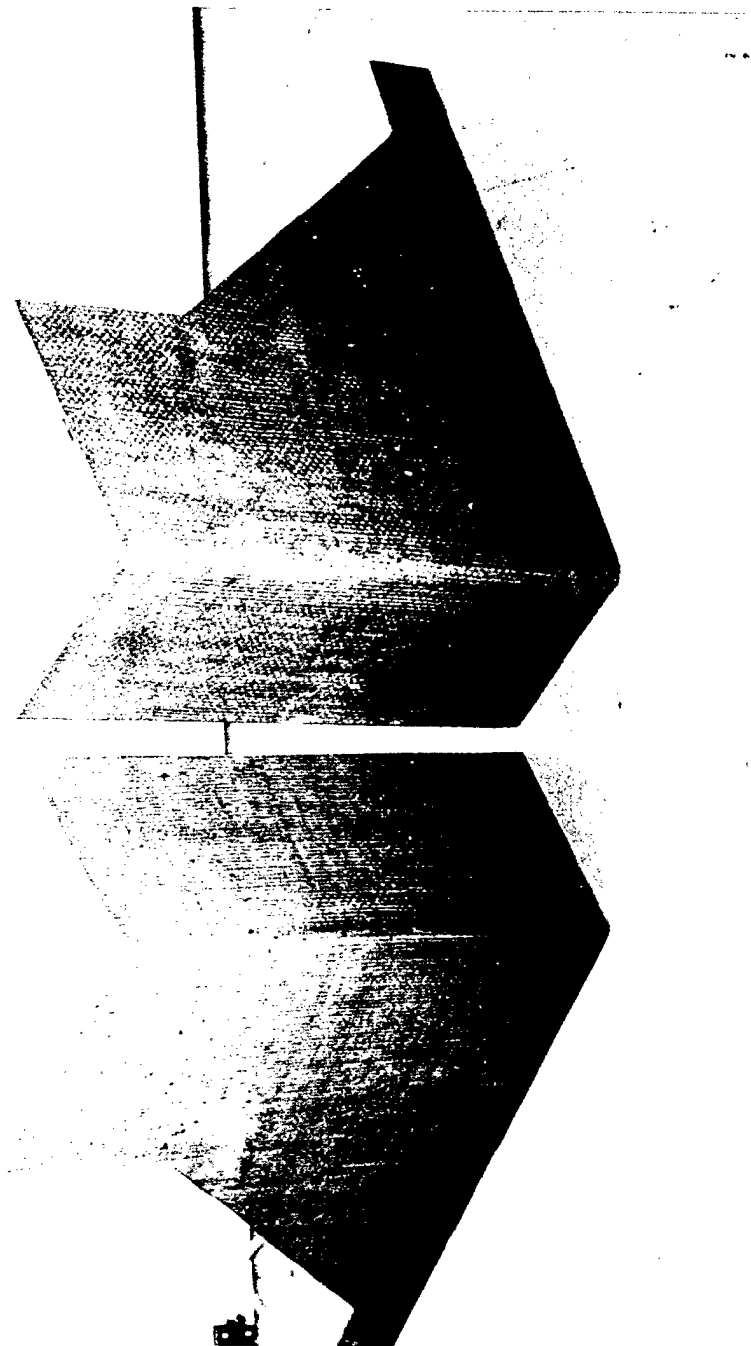

Figure 7. A Skirt Panel After Trimming to Size.

4.4. Bumper Panel Fabrication. The bumper panels in Figure 1 were surprisingly hard to fabricate as drawn, and only one serious attempt was made to do so. It was necessary to make the part on a male mold—the 90° angles made using a female mold too difficult for a wet layup or a VARTM process. Laying of the dry fabrics for the VARTM process would require bonding the individual fabric plies to each other with an adhesive that is soluble in the resin. It was expected that extensive experimentation would be required to identify an appropriate adhesive; this could take longer than the time available for the project. An alternative to this approach would be a stitched preform, but this would require extensive lead time.

Left- and right-handed male molds, 0.38 in smaller on all sides than the desired part size, were fabricated from 1-in Grade-A plywood. The molds were first dried in an oven at 250 °F for 4 hr. They were then coated with multiple coats of Shell Epon-826 epoxy resin,* and cured with Shell Epicure 3140 (formerly V40)† at 160 °F. The epoxy resin was sanded smooth between coats and given a final cure at 250 °F for 2 hr. A trial vacuum bag was built over each mold to ensure that it was leak tight prior to further preparation.

Once the molds were vacuum tight, five coats of Frekote-700-NC mold release‡ were applied. One ply of 5-mil nonporous Teflon-coated glass release fabric was then placed over the mold and secured in place with high-temperature tape. The bottom three layers of release/breather fabrics listed in Table 4 were then attached to the mold, which was then ready for use. A mold prepared to this stage is shown in Figure 8.

The 15-oz, 2 × 2 twill weave fabric was selected for fabrication of the part. This fabric is very flexible and can drape over the sides of the mold with ease. The fabric plies were cut in “cross” and “crown” patterns, shown in Figure 9. These were alternately applied to the mold.

* Inland Leidy, 2225 Evergreen Street, Baltimore, MD 21216.

† Miller-Stephenson Chemical Company, Inc., George Washington Highway, Danbury, CT 06810.

‡ The Dexter Corporation, Frekote Products, 1 Seabrook Drive, Seabrook, NH 03874.

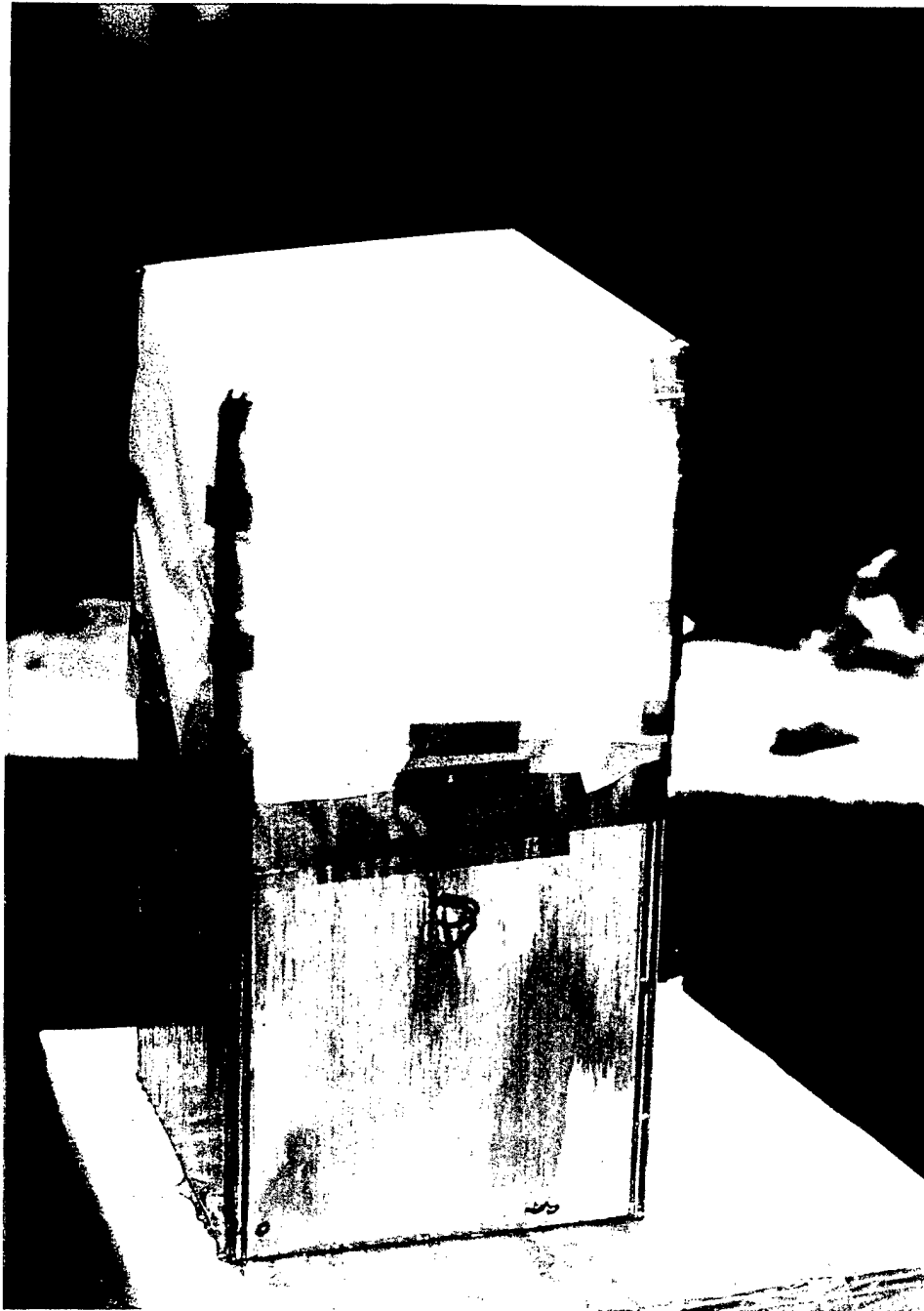

Figure 8. The Left-Handed Box Mold Used to Fabricate Bumper Panel Components in the Attempt at a Full-Up Bumper Panel.

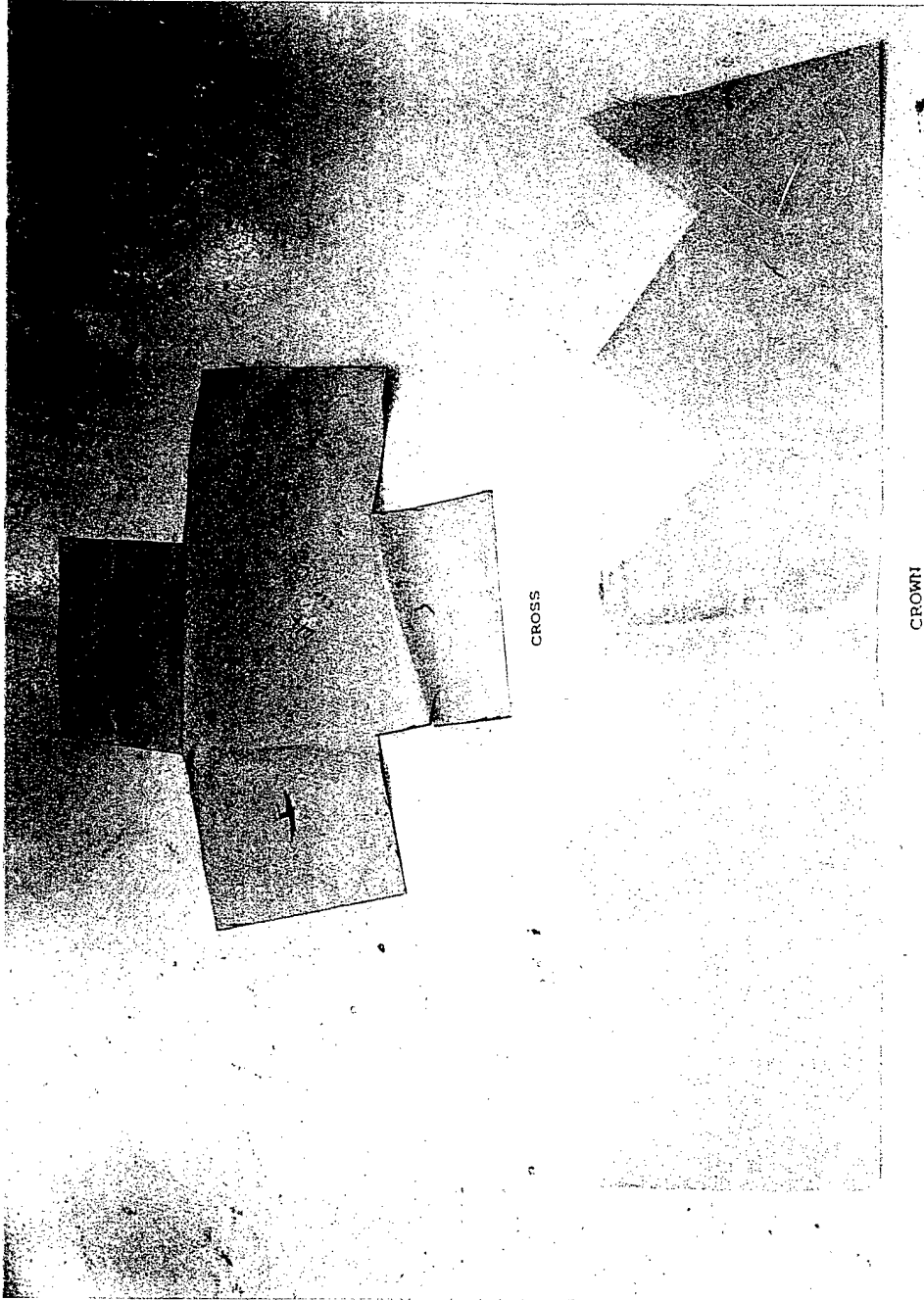

Figure 9. The Cross and Crown Cutting Patterns.

The crown pattern was selected with the expectation that it would not need to be stitched together in a wet layup process. If stitching had been needed (none was), it was also expected that the stitching could be done most easily in this configuration. The side cut in the crown plies was rotated to different sides on successive crown plies.

A 10-ply part (0.150 in thick) fabricated in this manner is shown in Figure 10. The biggest problem with the part was that none of the edges turned out even minimally well. A cross-shaped piece of 0.25-in silicone rubber was placed between the release/breather fabrics and the vacuum bag to help form the edges of the part; however, this did not help sufficiently. The edges would not have been a problem with a female mold. A female mold, through, presented other difficulties, as previously described.

The other problem encountered was that the part had to be cut to remove it from the mold, despite all precautions taken to apply sufficient release materials. The part quality would have undoubtedly improved on subsequent fabrication attempts. However, there was no expectation that a satisfactory part could have been made on a male mold. Since this was the case, another approach to making a bumper panel was adopted.

In the new approach, two flat 8-ply panels of the 24-oz woven roving, each 34 in \times 50 in, were first fabricated. For each bumper, five pieces of material corresponding to the four sides and an oversized top were cut from the flat stock. Two aluminum 90° V molds were used to fabricate eight L brackets approximately 10 in per side. The two wooden molds were used to fabricate special L brackets with the proper acute and obtuse angles, four for each bumper. Each of the 16 brackets was made with 10 plies of the 15-oz twill weave fabric.

The 90° L brackets and the flat stock for the two longer sides of the bumper were then bonded together in a simple fixture with Adiprene L-100 resin. Adhesive bond strength data for this resin is presented in the appendix. After trimming, these subassemblies were similar to those shown in Figure 11. The other two pieces of side flat stock were then bonded on, resulting in a 4-sided open box subassembly. This subassembly, four special L brackets, and the top are

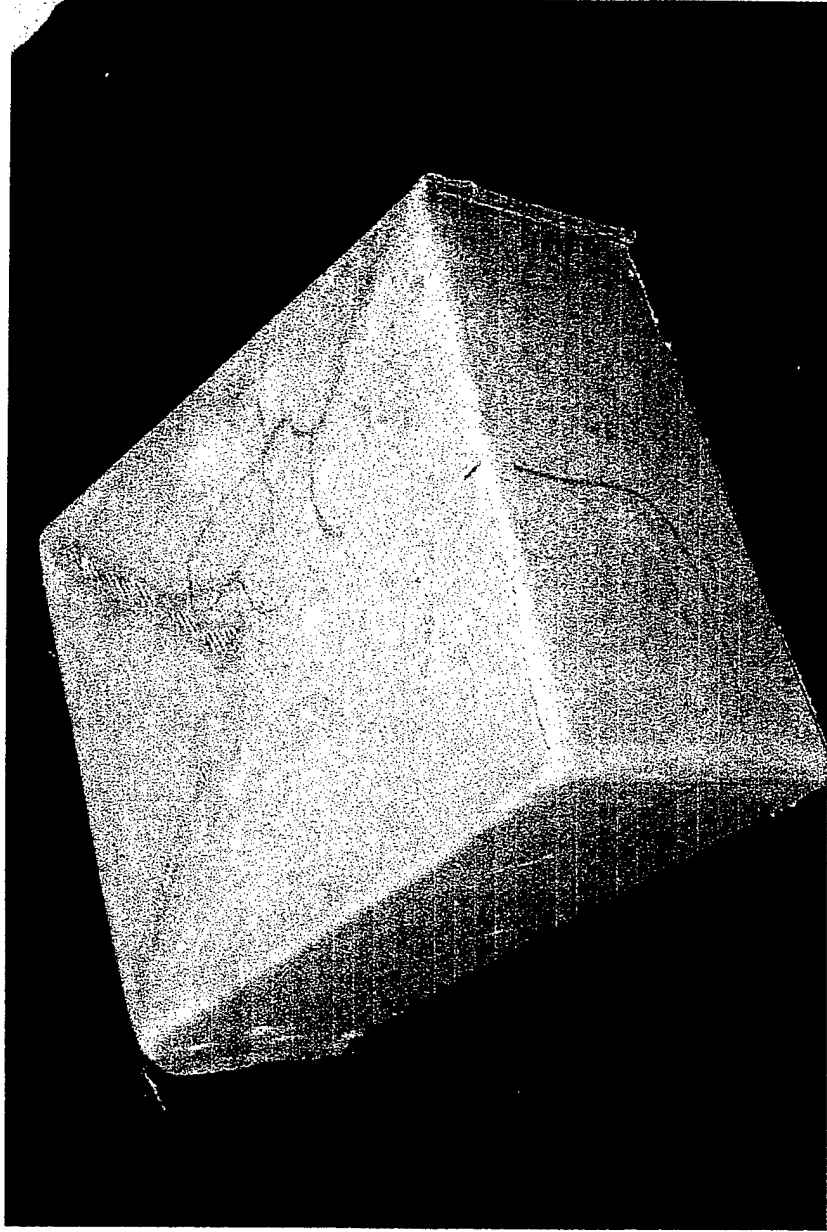

Figure 10. The 10-ply Part Fabricated on the Male Mold.



Figure 11. Two Initial Subassemblies for a Bumper.

shown ready for final assembly in Figure 12. Figure 13 shows the top being bonded to the open box. The edges of the top were then trimmed to size. Finally, about 1 in of unreinforced Adiprene resin was poured inside the bumper and cured. This was added to strengthen the bumper to what was thought to be an acceptable level. The finished bumpers are shown in Figure 14. Each weighed about 18.7 lb.

5. Possible Design Alternatives

5.1. Skirt Panels. The L-shaped skirt panels in this project require a mold for fabrication. Although the mold can be a relatively simple one-sided affair (such as the mold used in this project) for wet layup or VARTM, it complicates the fabrication of the panels. Aligning the panels for trimming to size is also somewhat complicated. Using two flat panels instead of the one L-shaped panel is a much simpler possibility to be considered for future efforts. The two panels would be able to move independently and could be made stiffer at the top if necessary. The two flat panels could also be joined using a molded rubber part which would allow them to move with a modest degree of independence. This would not be a difficult modification to implement.

5.2. Bumper Panels. The bumper panels fabricated for this project are complicated parts. Several simpler alternatives are possible and should be explored. The first of these is a thick (1.5 to 2 in), 5-sided box, similar to that shown in Figure 1, molded from hard polyurethane resin. The Adiprene L-100 is probably stiff and hard enough for this. If not, it can be stiffened by adding short (0.25 in) milled glass fibers to the resin. To attach the skirts, prefabricated glass-reinforced polyurethane matrix composite panels would be bonded to the hard rubber bumper on the four sides that are attached to the skirt panels or to the vehicle. These four panels would be molded in (if possible) and would not overlap. Holes for passing bolts or nuts and washers would also be molded into the polyurethane resin. This appears to be the simplest, least expensive option for the bumper.

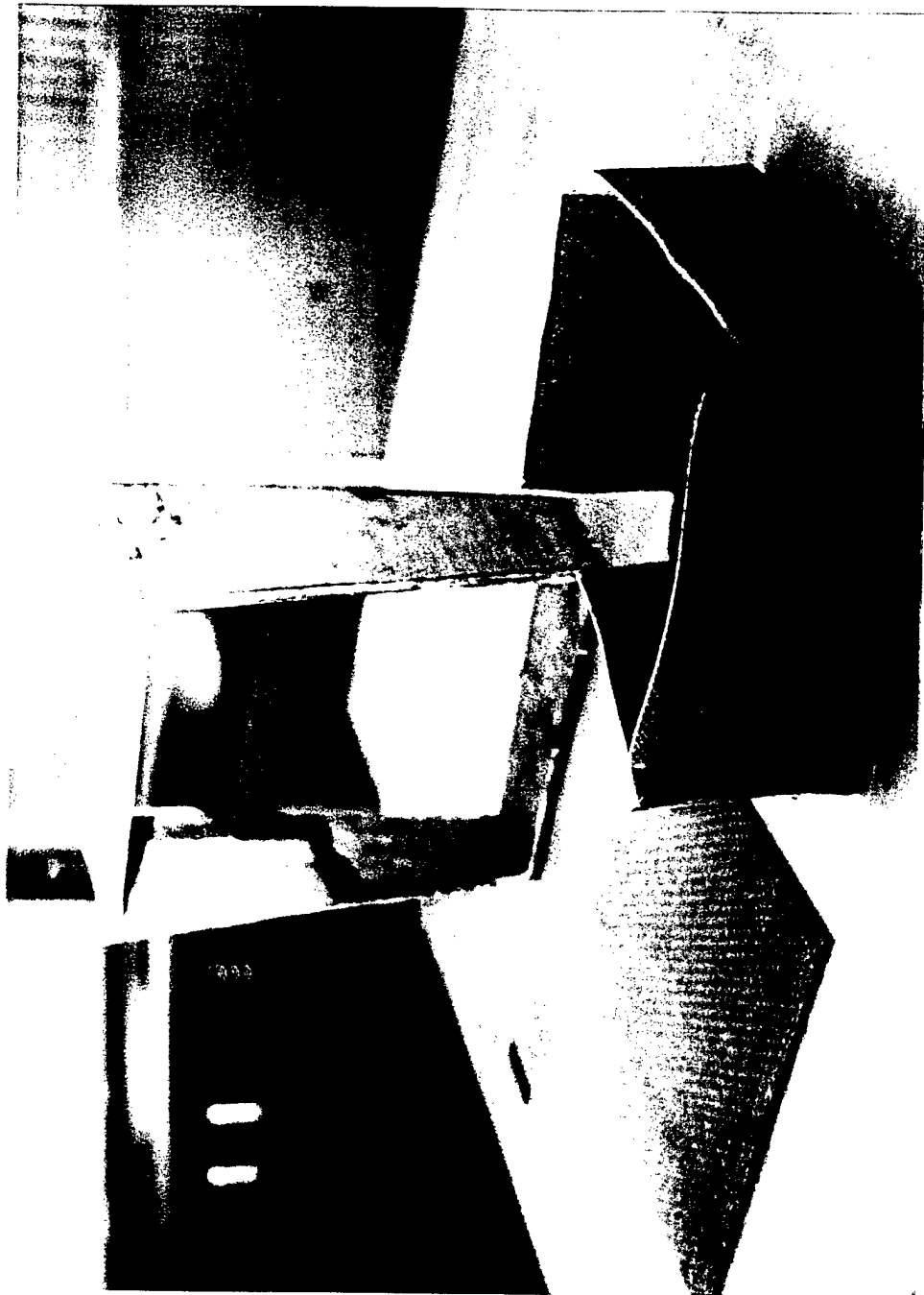

Figure 12. The Open Box Subassembly, Oversized Top, and Four Special L Brackets Ready for Final Assembly.

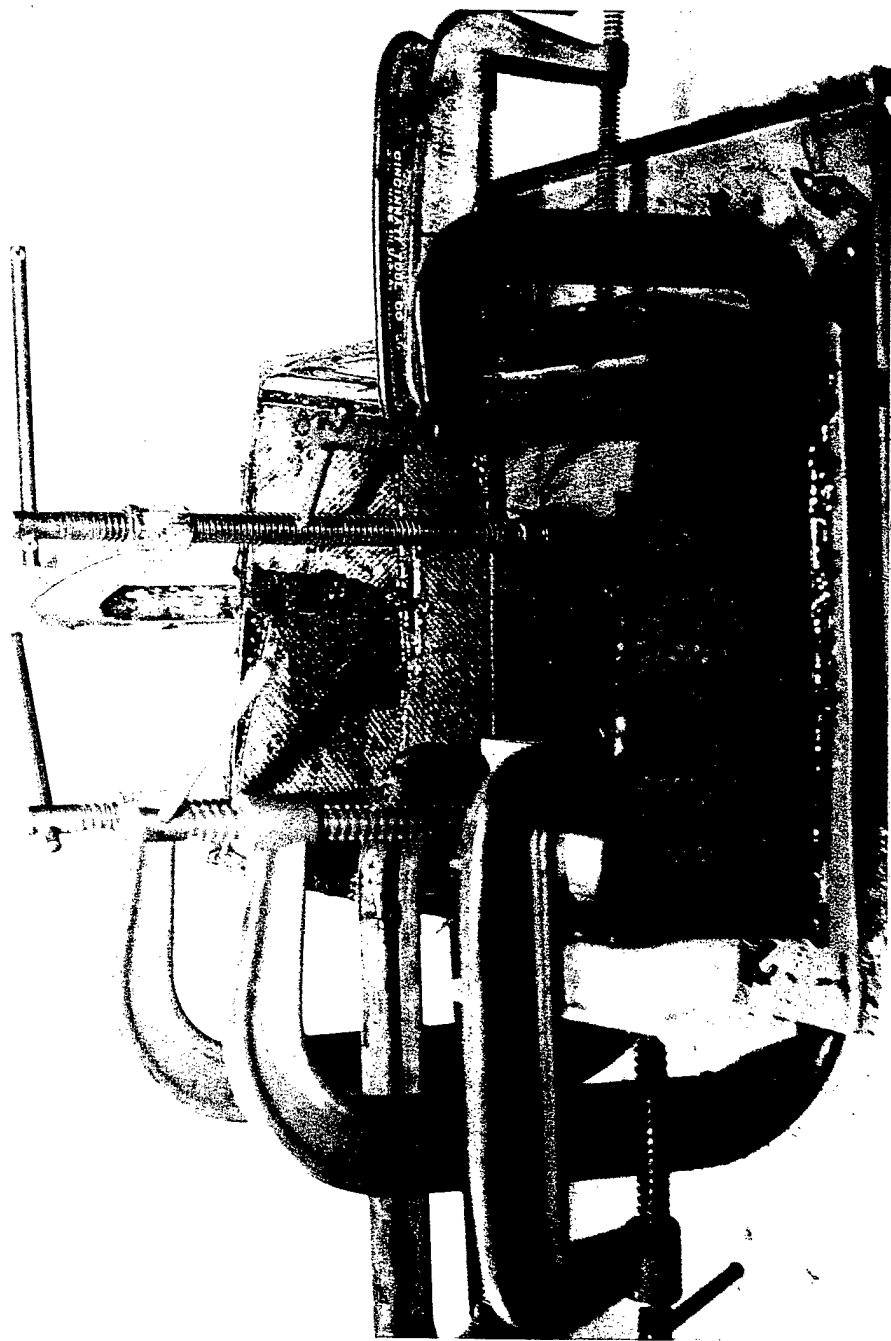

Figure 13. Bonding the Top to the Rest of the Bumper.



Figure 14. Completed Left and Right Bumpers.

A variation on this theme would shape the composite panels so that they also bond to the top. This would increase the bond area between the panels and the molded resin, thereby strengthening the part.

A third option would be to fabricate a composite part using only the cross pattern in Figure 10. This would then be placed in a female mold, and the thick polyurethane resin box would be poured in to finish the part. This seems more complex than necessary, however.

6. Conclusions

The materials selection for and fabrication of successful bumper and skirt panels for a niche application on an experimental ground vehicle have been described in detail. Possibilities for other uses of the bumper panels on Army ground vehicles should be explored.

INTENTIONALLY LEFT BLANK.

7. References

1. Spurgeon, W. A., R. B. Dooley, E. Rigas, D. Spagnuolo, A. Teets, and J. Bennett. "Development of a New Low Signature Track Skirt." ARL-TR-2141, U.S. Army Research Laboratory, Aberdeen Proving Ground, MD, 1999.
2. Crane, Roger. Personal communication with William Spurgeon. Naval Surface Warfare Center, Bethesda, MD, 1997.
3. American Society for Testing and Materials. *Standard Test Method for Tensile Properties of Plastics*. ASTM D638-97, West Conshohocken, PA, 1997.
4. American Society for Testing and Materials. *Standard Test Methods for Flexural Properties of Unreinforced and Reinforced Plastics and Insulating Materials*. ASTM D790-96A, West Conshohocken, PA, 1996.
5. Spurgeon, W. A. "Method of Fabricating Polymer Matrix Composites With a Low Volume Fraction of Fiber Reinforcement." ARL Invention Disclosure, March 1999.

INTENTIONALLY LEFT BLANK.

Appendix:

**Adhesive Bonding Adiprene Matrix
Composites – Preliminary Results**

INTENTIONALLY LEFT BLANK.

The ability to adhesive-bond the Adiprene L-100 matrix composite to itself was clearly needed for this project. A number of commercially available adhesives were tested, as was the Adiprene resin itself. The flexible adhesives included: Scotch-Grip 1300 Rubber & Gasket Adhesive,* Scotch-Grip 1357 High Performance Contact Adhesive,* and PR 1440-2-B polysulfide adhesive†. Chemlock 220‡ and Chemlock 233‡ adhesives, as well as Shell Epon-828 epoxy§ were tried as nonflexible adhesives. Shell Epon-828 epoxy was cured with 40 weight-percent Shell Epicure 3140 (formerly V40),** and was thickened with 25 weight-percent of milled E-glass fibers. Coupons of the Adiprene matrix composite 3 in long × 1 in wide were bonded together over a 1-in-long strip, and pulled apart, per American Society for Testing and Materials (ASTM) standard D3164-92A.¹ The test results are shown in Table A-1.

Table A-1. Adhesive Bond Strengths for Glass-Reinforced Adiprene Matrix Composite to Itself

Adhesive	Strength (lb)
Chemlock 233	No Bond
Chemlock 220	257 ± 90
Scotch-Grip 1300	125 ± 15
Scotch-Grip 1357	73 ± 10
Adiprene L-100	701 ± 14
PR 1440 polysulfide	205 ± 14
Epon 828-epoxy	428 ± 44

The Adiprene composites had been fabricated using a 3-mil porous Teflon-coated glass release fabric on either side. The release fabric left a surface rough enough for good adhesive bonding without further preparation. The samples were stamped out using a rubber cutting die.

* 3-M Industrial Tape and Specialties Division, St. Paul, MN 55144-1000.

† PRC-DeSoto International, 14126 NE 190th Street, Woodinville, WA 98072.

‡ Lord Corporation, Chemical Products Division, Erie, PA 16514-0038.

§ Inland Leidy, 2225 Evergreen Street, Baltimore, MD 21216.

** Miller-Stephenson Chemical Company, Inc., George Washington Highway, Danbury, CT 06810.

¹ American Society for Testing and Materials. *Standard Test Method for Strength Properties of Adhesively Bonded Plastic Lap-Shear Sandwich Joints in Shear by Tension Loading*. ASTM-D3164-92, West Conshohocken, PA, 1992.

All samples except the polysulfide and epoxy were cured by applying heat—1 hr at 250 °F for the samples bonded with Adiprene, and 4 hr at 160 °F for the others. The Chemlock adhesives normally do not require heat to cure; however unacceptably poor bond strengths were obtained if the coupons were not cured with heat. The polysulfide was cured at room temperature for 120 hr (48 hr should be sufficient). The epoxy was allowed to cure for seven days, at room temperature.

Every sample bonded with the Adiprene failed at the glass-resin matrix interface (the maximum bond strength that can be expected for this composite). In contrast, the Chemlock 220 and polysulfide adhesives pulled away from the Adiprene resin in the composite. All of the epoxy-bonded samples—except one—also failed in this manner.

The exception (not included in the data in Table A-1) pulled the Adiprene off the glass in the composite at about 630 lb of force. This indicated that the bonding with the epoxy could be improved, probably with better surface preparation. The Scotch-Grip adhesives both failed internally.

The ability to bond the Adiprene-based composite to steel and aluminum, to other composites such as glass-reinforced polyester, and to cured Adiprene resin was also desired for anticipated future applications. Only the polysulfide and epoxy adhesives were tried since room temperature bonding was desired. As before, the Adiprene composites were given no special preparation. The aluminum and steel samples were cleaned in acetone and alcohol, roughened extensively with 80-grit sandpaper, and re-cleaned. The cured polyurethane resin was roughened with a disc sander prior to use. The bond strength results are shown in Table A-2.

The steel, aluminum, and cured resin samples bonded to the composite with the polysulfide failed within the adhesive. The polyester-matrix composite bonded to the Adiprene-matrix composite failed at the polyester surface for both adhesives. The aluminum samples bonded to the Adiprene-matrix composite with the epoxy failed at the epoxy-aluminum interface. The epoxy bonded very well to the stainless steel—the best samples slipped in their grips at about

Table A-2. Adhesive Bond Strengths for Glass-Reinforced Adiprene Matrix Composite to Other Materials

Strength (lb)		
Material	Polysulfide	Epoxy
Steel	308 ± 22	> 630
2024 Aluminum	208 ± 36	143 ± 11
Cured Adiprene Resin	128 ± 21	> 180
Polyester-Glass Composite	178 ± 17	207 ± 41

630 lb of force. However, epoxy also bonded surprisingly well to the cured Adiprene—the Adiprene portion of the sample broke away from the rest of the sample at the edge of the bond to the epoxy at about 180 lb of force.

Finally, bonding the cured Adiprene resin to the polyester-glass composite was examined. A bond strength of 89 ± 5 lb was found for the polysulfide adhesive. As expected, every polysulfide-bonded sample failed at the adhesive-polyester interface. The cured Adiprene resin bonded to the polyester matrix with the epoxy also broke away from the rest of the sample at about 180 lb of force.

These results are intended only as an initial survey of adhesives for bonding the Adiprene resin and its composites to various materials. They indicate that good adhesive bonding to the polyurethane resin is possible and not difficult to obtain. Additional work, however, is needed in this area.

INTENTIONALLY LEFT BLANK

<u>NO. OF COPIES</u>	<u>ORGANIZATION</u>	<u>NO. OF COPIES</u>	<u>ORGANIZATION</u>
2	DEFENSE TECHNICAL INFORMATION CENTER DTIC DDA 8725 JOHN J KINGMAN RD STE 0944 FT BELVOIR VA 22060-6218	1	DIRECTOR US ARMY RESEARCH LAB AMSRL D D R SMITH 2800 POWDER MILL RD ADELPHI MD 20783-1197
1	HQDA DAMO FDT 400 ARMY PENTAGON WASHINGTON DC 20310-0460	1	DIRECTOR US ARMY RESEARCH LAB AMSRL DD 2800 POWDER MILL RD ADELPHI MD 20783-1197
1	OSD OUSD(A&T)/ODDDR&E(R) R J TREW THE PENTAGON WASHINGTON DC 20301-7100	1	DIRECTOR US ARMY RESEARCH LAB AMSRL CI AI R (RECORDS MGMT) 2800 POWDER MILL RD ADELPHI MD 20783-1145
1	DPTY CG FOR RDA US ARMY MATERIEL CMD AMCRDA 5001 EISENHOWER AVE ALEXANDRIA VA 22333-0001	3	DIRECTOR US ARMY RESEARCH LAB AMSRL CI LL 2800 POWDER MILL RD ADELPHI MD 20783-1145
1	INST FOR ADVNCD TCHNLGY THE UNIV OF TEXAS AT AUSTIN PO BOX 202797 AUSTIN TX 78720-2797	1	DIRECTOR US ARMY RESEARCH LAB AMSRL CI AP 2800 POWDER MILL RD ADELPHI MD 20783-1197
1	DARPA B KASPAR 3701 N FAIRFAX DR ARLINGTON VA 22203-1714		<u>ABERDEEN PROVING GROUND</u>
1	NAVAL SURFACE WARFARE CTR CODE B07 J PENNELLA 17320 DAHLGREN RD BLDG 1470 RM 1101 DAHLGREN VA 22448-5100	4	DIR USARL AMSRL CI LP (BLDG 305)
1	US MILITARY ACADEMY MATH SCI CTR OF EXCELLENCE MADN MATH MAJ HUBER THAYER HALL WEST POINT NY 10996-1786		

NO. OF
COPIES ORGANIZATION

1 COMMANDER
US ARMY ARMOR CENTER
ATZK MW
S BLASKE
FT KNOX KY 40121

1 COMMANDER
US ARMY ARDEC
AMSTA AR CCH C
BUILDING 65
S CHICO
PICATINNY ARSENAL NJ
07806-5000

1 PM SADARM
SFAE GCSS SD PM
PICATINNY ARSENAL NJ
07806-5000

2 PM TMAS
SFAE GSSC TMA
COL PAWLICKI
K KIMKER
PICATINNY ARSENAL NJ
07806-5000

3 PM CRUSADER
SFAE GCSS C PM
G DELCOCO
J SHIELDS
PICATINNY ARSENAL NJ
07806-5000

3 COMMANDER
US ARMY ARDEC
AMSTA AR TECH DIRECTOR
AMSTA AR M D DEMELLA
AMSTA AR FSA C CHIEFA
PICATINNY ARSENAL NJ
07806-5000

3 COMMANDER
US ARMY AVCMCOM
AMSMI RD W MCCORKLE
AMSMI RD ST CN T VANDIVER
AMSMI RD ST W PITTMAN
REDSTONE ARSENAL AL
35898-5247

NO. OF
COPIES ORGANIZATION

1 COMMANDER
US ARMY AVCMCOM
AMC SMART WEAPONS MGMT OFFICE
AMSMI SW D SAINSBURY
REDSTONE ARSENAL AL
35898-5000

1 US ARMY RESEARCH OFFICE
J PRATER
PO BOX 12211
RESEARCH TRIANGLE PARK NC
27709-2211

1 COMMANDANT
US ARMY FIELD ARTILLERY CTR
AT FT SILL
ATFS CD LTC BUMGARNER
FT SILL OK 73503-5600

1 DIRECTOR
US ARMY AVCMCOM
COMANCHE PRGRM MGR'S OFFICE
SFAE AV RAM TV D CALDWELL
BUILDING 5300
REDSTONE ARSENAL AL 35898

3 COMMANDER
US ARMY TACOM
PM TACTICAL VEHICLES
SFAE TVL
SFAE TVM
SFAE TVH
WARREN MI 48397-5000

1 COMMANDER
US ARMY TACOM
PM ABRAMS
SFAE ASM AB
WARREN MI 48397-5000

1 COMMANDER
US ARMY TACOM
PM BFVS
SFAE ASM BV
WARREN MI 48397-5000

1 COMMANDER
US ARMY TACOM
PM SURV SYS
SFAE ASM SS T DEAN
WARREN MI 48397-5000

<u>NO. OF COPIES</u>	<u>ORGANIZATION</u>
3	COMMANDER US ARMY SOLDIER SYS CMND NATICK RD&E CENTER SSCNC WST W NYKVIST T MERRILL S BEAUDOIN NATICK MA 01760-5018
1	GEORGIA INST OF TCHNLGY GEORGIA TECH RSRCH CORP RSRCH SECURITY DEPT SECURITY OFFICER P FRIEDERICH ATLANTA GA 30332
1	LOCKHEED MARTIN SKUNK WORKS D FORTNEY 1011 LOCKHEED WAY PALMDALE CA 93599-2174
1	COMMANDER NAVAL SURFACE WARFARE CTR CARDEROCK DIVISION R PETERSON CODE 2020 BETHESDA MD 20084
2	UNITED DEFENSE LP PO BOX 359 R BRYNSVOLD D MARTIN SANTA CLARA CA 95052-0359
1	OFFICE OF THE SCRTRY OF DEFNS JOINT CCD TEST FORCE OSD JCCD R WILLIAMS 3909 HALLS FERRY ROAD VICKSBURG MS 29180-6199
2	GDLS D REES M PASIK PO BOX 1800 WARREN MI 48090
1	PACIFIC NORTHWEST LAB CMCC P8 60 T HALL PO BOX 999 RICHLAND WA 99352

<u>NO. OF COPIES</u>	<u>ORGANIZATION</u>
2	THE BOEING COMPANY W HAMMOND J RUSSELL MS 4X55 PO BOX 3707 SEATTLE WA 98124-2207
1	GDLS MUSKEGON OPERATIONS W SOMMERS JR 76 GETTY STREET MUSKEGON MI 49442
2	DEFENSE TECHNICAL INFO CTR DTIC DDA 8725 JOHN J KINGMAN ROAD STE 0944 FT BELVOIR VA 22060-6218
1	DIRECTOR US ARMY RESEARCH LAB AMSRL VS W ELBER NASA LANGLEY RESEARCH CTR HAMPTON VA 23681-0001
1	COMMANDER US ARMY ARDEC AMSTA AR FSP A P KISATSKY PICATINNY ARSENAL NJ 07806-5000
1	DEPARTMENT OF THE ARMY OASARDA SARD SO DIRECTOR 103 ARMY PENTAGON WASHINGTON DC 20310-0103
4	DIRECTOR US ARMY NGIC D LEITER S EITELMAN M HOLTUS M WOLFE 220 SEVENTH STREET NE CHARLOTTESVILLE VA 22091

NO. OF
COPIES ORGANIZATION

6 COMMANDER
US ARMY TACOM
AMSTA TR
R D THOMAS
J BENNETT
D HANSEN
AMSTA JSK S GOODMAN
AMSTA TR D
D OSTBERG
L HINOJOSA
WARREN MI 48397-5000

3 DIRECTOR
US ARMY CECOM
NIGHT VISION AND ELCTRNC
SNSRS DIRCTRTE
AMSEL RD NV CM CCD
R ADAMS
A YINGST
AMSEL RD NV VISP
E JACOBS
10221 BURBECK ROAD
FT BELVOIR VA 22060-5806

1 DPTY ASSIST SCY FOR R&T
SARD TT DIRECTOR
RM3EA79 THE PENTAGON
WASHINGTON DC 20301-7100

1 NORTHRUP GRUMMAN CORP
ELCTRNC SNSRS AND SYS DIV
K RADFORD
PO BOX 17191
PITTSBURGH PA 15235-0191

1 NORTHRUP GRUMMAN CORP
K F SCHOCH
PO BOX 1693
LINTHICUM MD 21203-1693

3 DIRECTOR
US ARMY RESEARCH LAB
AMSRL SE L
R WEINRAUB
J DESMOND
D WOODBURY
2800 POWDER MILL RD
ADELPHI MD 20783-1197

NO. OF
COPIES ORGANIZATION

4 DIRECTOR
US ARMY RESEARCH LAB
AMSRL SE R
H B WALLACE
AMSRL SE RE
R CHASE
AMSRL SE DS
R REYZER
R ATKINSON
2800 POWDER MILL RD
ADELPHI MD 20783-1197

1 DIRECTOR
US ARMY RESEARCH LAB
AMSRL CS AS RECORDS MGMT
2800 POWDER MILL RD
ADELPHI MD 20783-1145

3 DIRECTOR
US ARMY RESEARCH LAB
AMSRL CI LL
2800 POWDER MILL RD
ADELPHI MD 20783-1145

1 GENERAL DYNAMICS
AMPHIBIOUS SYS
G WALKER
SURVIVABILITY LEAD
PO BOX 4670
WOODBIDGE VA 22194-4670

ABERDEEN PROVING GROUND

4 DIR USARL
AMSRL CI LP 305

36 DIR USARL
AMSRL WM M
D VIECHNICKI
LTC TANNER
AMSRL WM MA
R SHUFORD
J ESCARSEGA
C PERGANTIS
K CHESONIS
J DUNCAN
G RODRIGUEZ
A TEETS

NO. OF
COPIES ORGANIZATION

AMSRL WM MB
J BENDER
R BOSSOLI
L BURTON
S CORNELISON
P DEHMER
R DOOLEY
W DRYSDALE
B FINK
D GRANVILLE
R LIEB
E RIGAS
D SPAGNUOLO
W SPURGEON
AMSRL WM MC
J BEATTY
AMSRL WM MD
W ROY
S WALSH
AMSRL WM T
B BURNS
AMSRL WM TA
W GILlich
W BRUCHEY
T HAVEL
W GOOCH
J RUNYEON
AMSRL WM TD
T HADUCH
AMSRL WM B
A HORST
AMSRL WM BA
W DAMICO
AMSRL WM BF
J LACETERA
AMSRL SL BL
R HENRY

INTENTIONALLY LEFT BLANK.

REPORT DOCUMENTATION PAGE

Form Approved
OMB No. 0704-0188

Public reporting burden for this collection of information is estimated to average 1 hour per response, including the time for reviewing instructions, searching existing data sources, gathering and maintaining the data needed, and completing and reviewing the collection of information. Send comments regarding this burden estimate or any other aspect of this collection of information, including suggestions for reducing this burden, to Washington Headquarters Services, Directorate for Information Operations and Reports, 1215 Jefferson Davis Highway, Suite 1204, Arlington, VA 22202-4302, and to the Office of Management and Budget, Paperwork Reduction Project(0704-0188), Washington, DC 20503.

1. AGENCY USE ONLY (Leave blank)	2. REPORT DATE September 2000	3. REPORT TYPE AND DATES COVERED Final, Apr 99-Sep 99	
4. TITLE AND SUBTITLE Fabrication of Novel Bumper and Skirt Components for a Ground Vehicle		5. FUNDING NUMBERS 622618AH80	
6. AUTHOR(S) William A. Spurgeon and David J. Thomas*			
7. PERFORMING ORGANIZATION NAME(S) AND ADDRESS(ES) U.S. Army Research Laboratory ATTN: AMSRL-WM-MB Aberdeen Proving Ground, MD 21005-5069		8. PERFORMING ORGANIZATION REPORT NUMBER ARL-TR-2327	
9. SPONSORING/MONITORING AGENCY NAMES(S) AND ADDRESS(ES)		10. SPONSORING/MONITORING AGENCY REPORT NUMBER	
11. SUPPLEMENTARY NOTES * U.S. Army Tank-Automotive Research, Development, and Engineering Center, Warren, MI 48397-5000			
12a. DISTRIBUTION/AVAILABILITY STATEMENT Approved for public release; distribution is unlimited.		12b. DISTRIBUTION CODE	
13. ABSTRACT (Maximum 200 words) This report discusses the materials selection for and fabrication of novel "bumper" and skirt panels for an experimental ground vehicle improvement project. These components were fabricated from E-glass reinforced polyurethane resin so that they would have a unique combination of rigidity and flexibility required for successful field use. Alternative components for future consideration are discussed, and some initial work on adhesive bonding of polyurethane matrix composites is presented.			
14. SUBJECT TERMS track skirt, bumpers, polyurethane resin composites		15. NUMBER OF PAGES 42	
		16. PRICE CODE	
17. SECURITY CLASSIFICATION OF REPORT UNCLASSIFIED	18. SECURITY CLASSIFICATION OF THIS PAGE UNCLASSIFIED	19. SECURITY CLASSIFICATION OF ABSTRACT UNCLASSIFIED	20. LIMITATION OF ABSTRACT UL

INTENTIONALLY LEFT BLANK.