

Award Number: DAMD17-98-1-8265

TITLE: Recombinant Breast Cancer Vaccines

PRINCIPAL INVESTIGATOR: Shari Pilon  
Wei-Zen Wei, Ph.D.

CONTRACTING ORGANIZATION: Wayne State University  
Detroit, Michigan 48202

REPORT DATE: September 1999

TYPE OF REPORT: Annual Summary

PREPARED FOR: U.S. Army Medical Research and Materiel Command  
Fort Detrick, Maryland 21702-5012

DISTRIBUTION STATEMENT: Approved for public release  
distribution unlimited

The views, opinions and/or findings contained in this report are those of the author(s) and should not be construed as an official Department of the Army position, policy or decision unless so designated by other documentation.

**DTIC QUALITY INSPECTED 4**

**20001124 062**

# REPORT DOCUMENTATION PAGE

*Form Approved*  
**OMB No. 074-0188**

Public reporting burden for this collection of information is estimated to average 1 hour per response, including the time for reviewing instructions, searching existing data sources, gathering and maintaining the data needed, and completing and reviewing this collection of information. Send comments regarding this burden estimate or any other aspect of this collection of information, including suggestions for reducing this burden to Washington Headquarters Services, Directorate for Information Operations and Reports, 1215 Jefferson Davis Highway, Suite 1204, Arlington, VA 22202-4302, and to the Office of Management and Budget, Paperwork Reduction Project (0704-0188), Washington, DC 20503

<b>1. AGENCY USE ONLY (Leave blank)</b>		<b>2. REPORT DATE</b> September 1999	<b>3. REPORT TYPE AND DATES COVERED</b> Annual Summary (1 Sep 98 – 31 Aug 99)	
<b>4. TITLE AND SUBTITLE</b> Recombinant Breast Cancer Vaccines			<b>5. FUNDING NUMBERS</b> DAMD17-98-1-8265	
<b>6. AUTHOR(S)</b>  Shari Pilon Wei-Zen Wei, Ph.D.				
<b>7. PERFORMING ORGANIZATION NAME(S) AND ADDRESS(ES)</b> Wayne State University Detroit, Michigan 48202  e-mail: <a href="mailto:weiw@karmanos.org">weiw@karmanos.org</a> / <a href="mailto:spilon@med.wayne.edu">spilon@med.wayne.edu</a>			<b>8. PERFORMING ORGANIZATION REPORT NUMBER</b>	
<b>9. SPONSORING / MONITORING AGENCY NAME(S) AND ADDRESS(ES)</b> U.S. Army Medical Research and Materiel Command Fort Detrick, Maryland 21702-5012			<b>10. SPONSORING / MONITORING AGENCY REPORT NUMBER</b>	
<b>11. SUPPLEMENTARY NOTES</b>				
<b>12a. DISTRIBUTION / AVAILABILITY STATEMENT</b> Approved for public release distribution unlimited				<b>12b. DISTRIBUTION CODE</b>
<b>13. ABSTRACT (Maximum 200 Words)</b> Recombinant DNA vaccines encoding mutant ErbB-2, a transmembrane tyrosine kinase mediating oncogenic activity, have been constructed. In ERBB-2A (E2A), tyrosine kinase activity was eliminated by replacing the ATP binding residue 753 lysine with alanine. To generate cytosolic proteins, (cytE2, cytE2A), the ER signal sequence was deleted. Vaccination of BALB/c mice with DNA encoding transmembrane E2 or E2A induced anti-ErbB-2 antibodies and anti-tumor immunity, with E2 being more potent than E2A. Elimination of CD4 T cells prevented the induction of anti-ErbB-2 antibody which, therefore, serves as an indicator of CD4 help. Vaccination with cytE2A induced little protection against tumor growth and no antibody production. Co-vaccination with cytE2A and plasmid encoding IL-2 or GM-CSF protected 80% of mice against tumor challenge although no antibody was induced. These results indicated that CD4 T cell activation by transmembrane ERBB-2 but not cytoplasmic ERBB-2 was critical to anti-tumor immunity and can be replaced, in part, by cytokine co-vaccination and that signal transduction by ErbB-2 may contribute to ErbB-2 immunogenicity.				
<b>14. SUBJECT TERMS</b> Breast Cancer				<b>15. NUMBER OF PAGES</b> 24
				<b>16. PRICE CODE</b>
<b>17. SECURITY CLASSIFICATION OF REPORT</b> Unclassified	<b>18. SECURITY CLASSIFICATION OF THIS PAGE</b> Unclassified	<b>19. SECURITY CLASSIFICATION OF ABSTRACT</b> Unclassified	<b>20. LIMITATION OF ABSTRACT</b> Unlimited	

FOREWORD

Opinions, interpretations, conclusions and recommendations are those of the author and are not necessarily endorsed by the U.S. Army.

\_\_\_ Where copyrighted material is quoted, permission has been obtained to use such material.

\_\_\_ Where material from documents designated for limited distribution is quoted, permission has been obtained to use the material.

\_\_\_ Citations of commercial organizations and trade names in this report do not constitute an official Department of Army endorsement or approval of the products or services of these organizations.

In conducting research using animals, the investigator(s) adhered to the "Guide for the Care and Use of Laboratory Animals," prepared by the Committee on Care and use of Laboratory Animals of the Institute of Laboratory Resources, national Research Council (NIH Publication No. 86-23, Revised 1985).

\_\_\_ For the protection of human subjects, the investigator(s) adhered to policies of applicable Federal Law 45 CFR 46.

\_\_\_ In conducting research utilizing recombinant DNA technology, the investigator(s) adhered to current guidelines promulgated by the National Institutes of Health.

\_\_\_ In the conduct of research utilizing recombinant DNA, the investigator(s) adhered to the NIH Guidelines for Research Involving Recombinant DNA Molecules.

\_\_\_ In the conduct of research involving hazardous organisms, the investigator(s) adhered to the CDC-NIH Guide for Biosafety in Microbiological and Biomedical Laboratories.

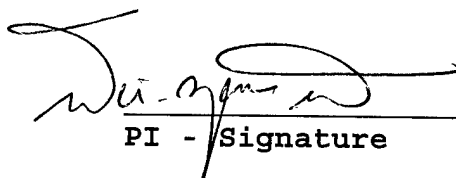
  
PI - Signature

9/27/99  
Date

## Table of Contents

Front Cover -----	1
Report Documentation Page -----	2
Foreword -----	3
Table of Contents -----	4
Introduction -----	5
Body of Proposal -----	5
Key Research Accomplishments -----	8
Reportable Outcomes -----	8
Conclusions -----	9
Acronym and Symbol Definition -----	10
Figures -----	11
References -----	16
Appendix A-----	17

## **INTRODUCTION**

The goal of this study is to prevent the growth or recurrence of breast cancer by active vaccination with a tumor antigen, ErbB-2. The specific objectives are to generate and test recombinant vaccines which can induce a strong anti-tumor immune response. Human tumor associated antigens, such as ErbB-2, are generally self antigens and may be associated with transforming activities. In our recombinant vaccines, the transforming activity of ERBB-2 is eliminated by point mutation. Recombinant ErbB-2 molecules are directed to the subcellular compartments of antigen processing and presentation and the generation of an anti-tumor immune response is characterized. Co-vaccination with cytokines such as IL-2 or in adenoviral vectors is also tested. The reagents developed in this study will be candidate breast cancer vaccines. The principles established by this study will be applicable to new tumor antigens.

## **SPECIFIC TASKS**

- 1 Continue to modify and test recombinant cytoplasmic erbB-2 which is free of tyrosine kinase activity
- 2 Construct and test recombinant ERBB-2 which is targeted to MHC II antigen processing pathway
- 3 Enhance vaccine efficacy by local IL-2 secretion and by expression with adenoviral vectors

## **STUDIES AND RESULTS**

**Task 1 Continue to modify and test recombinant cytoplasmic ErbB-2 which is free of tyrosine kinase activity.**

### **1.1 Elimination of tyrosine kinase activity in wild-type and cytoplasmic ERBB-2 gene products**

Results from this study has been reported in Appendix A. To eliminate tyrosine kinase activity, the ATP binding lysine residue 753 was substituted with alanine by replacing codon AAA with GCA in mutant ERBB-2 (E2A). To direct recombinant ErbB-2 to the cytoplasm where MHC I peptide processing takes place, the ER signal sequence was deleted to generate cytoplasmic ERBB-2 (cytE2). CytE2A contains the cytoplasmic ERBB-2 with the K to A mutation. Mouse mammary tumor cell line D2F2 was transfected with the mutant constructs and stable transfectants were selected. Expression of recombinant proteins was measured by flow cytometry. Transmembrane ErbB-2 and ErbB-2A were readily detected. Cytoplasmic ErbB-2 and cytErbB-2A were detected only after the transfected cells were incubated overnight with a proteasome inhibitor, indicating degradation shortly after synthesis.

To determine if the recombinant ErbB-2 exhibits tyrosine kinase activity, Western Blot analysis was performed to detect phosphorylated tyrosine on the recombinant proteins. Recombinant ErbB-2 and cytErbB-2, but not their mutant counterparts, demonstrated phosphorylated tyrosine. Therefore, substitution of tyrosine with alanine eliminated tyrosine kinase activity and thus oncogenic activity.

## 1.2 Attempt to test the immunogenicity of wt ERBB-2 and cyt ERBB-2 with peptide specific CTL lysis.

To test the processing and presentation of ERBB-2 associated antigenic peptides, we attempted to generate ErbB-2 specific CTL. The ErbB-2 peptide HE63 (TYLPTNASL) was previously shown to contain a K<sup>d</sup> anchor motif with Y at P2 and L/V at P9 and bind K<sup>d</sup> with a high affinity (1 and our unpublished results). BALB/C mice were immunized by s.c. injection with 100 µg of HE63 emulsified in Complete Freund's Adjuvant (CFA) and boosted two times with HE63 in IFA. Immune lymphocytes were collected and stimulated *in vitro* with HE63 coated bone marrow derived dendritic cells (DC). DC were generated as described by Inaba et al. (7), with some modifications. Briefly, bone marrow cells were flushed from the femurs of BALB/C mice and cultured in RPMI 1640 media supplemented with 10% heat inactivated fetal calf serum, 10ng/ml recombinant murine IL-4, and 10 ng/ml recombinant murine GM-CSF. Non-adherent cells were discarded after 24 hours. After the adherent cells were cultured for an average of seven days, the floating and loosely adherent cells were collected and analyzed by flow cytometry for their expression of MHC class I and II and B7.1. These cells were used as stimulators in CTL cultures. Lysis of ERBB-2 transfected D2F2 (D2F2/E2) cells by anti-HE63 CTL were measured in a standard chromium release assay. Non-transfected and HE63 coated cells were used as controls. Very low level killing of HE63 coated D2F2 cells was seen while D2F2/E2 cells were not killed (Figure 1). Therefore, our results do not indicate HE63 as a strong ErbB-2 epitope.

It was reported that membrane-bound proteins are targeted to the ER and undergo N-glycosylation on asparagine (N) at an N-X-S/T motif by the enzyme Oligosaccharyl transferase. When such glycosylated proteins enter the cytosol, the carbohydrate moiety is removed by Peptide N glycanase and the asparagine residue is converted to an aspartic acid (D) residue (2). An example was found in the HLA-A2 restricted peptide YMDGTMSQV on melanoma cells which was converted from the native YMNGTMSQV. Although both peptides bind HLA-A2 equally, the peptide containing the D residue was recognized by CTL with 100 times greater efficiency than the N containing peptide (3). The HE63 peptide for ErbB-2 also contains the N-X-S/T motif and should be glycosylated on the asparagine residue in the ER. This residue may be converted to an aspartic acid residue in the cytosol prior to its presentation by MHC I molecules. Therefore, the peptide HE63D (TYLPTDASL) was examined as a possible epitope for CTL induction. Mice were immunized and immune lymphocytes were tested as described above. HE63D induced CTL and lysed HE63D coated D2F2 cells at high frequencies. There was, however, no lysis of D2F2/E2 cells. (Figure 2). Therefore, peptide HE63D is more immunogenic than HE63 but neither peptide appears to be an immunodominant peptide from ErbB-2. An alternative strategy to measure T cell response was tested and the results are described in section 3.2.2.

### Task 2 Construct and test recombinant ERBB-2 which is targeted to MHC II antigen processing pathway

Construction and characterization of a recombinant ErbB-2 targeted to the MHC II antigen processing pathway is scheduled to begin in month 18.

### **Task 3 Enhance vaccine efficacy by local IL-2 secretion and by expression with adenoviral vectors**

#### **3.1 Tumor rejection after co-immunization with pCMV/cytE2A and cytokine genes**

To test if the efficacy of vaccination with cytE2A can be enhanced, we measured the effect of co-vaccination with IL-2 or GM-CSF cytokine genes. IL-2 is required for the proliferation of cytotoxic T cells, helper T cells and natural killer cells, all of which can participate in an anti-tumor response (4). GM-CSF facilitates the induction of primary immune responses by activating and recruiting professional antigen presenting cells (APC's) (5). BALB/C mice were immunized 3 times at 2 week intervals by i.m. injection in the thigh with 100 µg of pCMV/cytE2A, pEFBos/IL-2, pEFBos/GM-CSF, pCMV/cytE2A + pEFBos/IL-2, or pCMV/cytE2A + pEFBos/GM-CSF. The control group received pCMV vector. Immunized mice were challenged s.c. with  $2 \times 10^5$  D2F2/E2 cells two weeks after the last vaccination. Vaccination with pCMV/cytE2A had little protective effect and 9 of 10 mice developed tumors. Vaccination with cytokine genes alone had little protective effect. Mice injected with pCMV/E2A and plasmid encoding IL-2 or GM-CSF were resistant to tumor challenge and only 2 of 10 mice developed tumors (Figure 3). These results are consistent with the notion that anti-tumor immunity is induced by pCMV/cytE2A when co-stimulation is provided by genes encoding cytokines.

#### **3.2 Defining the anti-tumor immunity induced by cytE2A**

The nature of the immune response induced by co-vaccination with pCMV/cytE2A and pEFBos/IL-2 or GM-CSF was explored by determining the humoral and cellular immune responses induced by vaccination with recombinant ERBB-2.

##### **3.2.1 Induction of humoral and CD4 T cell responses**

Previous studies have shown that vaccination with three i.m. injections with 100 µg each of pCMV/E2, E2A, cytE2, or cytE2A protected 100, 60, 12 and 0% of BALB/C mice, respectively, against D2F2/E2 (6). Vaccination with pCMV/E2 or pCMV/E2A induced anti-ErbB-2 antibody as measured by binding to ErbB-2 on SKBR3 cells using flow cytometry. Vaccination with pCMV/cytE2 or pCMV/cytE2A did not induce an antibody response (Figure 4A). Similarly, growth of D2F2 tumors expressing membrane E2 and E2A also resulted in anti-ErbB-2 antibodies. No antibody was induced after injection of D2F2 tumors expressing cytE2 or cytE2A (Figure 4B). This is consistent with the finding that the cytoplasmic ErbB-2 proteins are rapidly degraded and not presented on the surface of the cell. Antibody production is indicative of a CD4 T helper cell response. Depletion of CD4 T cells with monoclonal antibody GK1.5 before tumor injection abolished antibody production (Figure 5). Ineffective anti-tumor immunity may be the result of an inadequate CD4 T cell response induced by vaccination with pCMV/cytE2 and cytE2A. While co-vaccination of cytE2A and GM-CSF genes does not result in anti-ErbB-2 antibody production (Figure 4A), cytokine expression may replace the need for CD4 T cell help

##### **3.2.2 Induction of CTL response**

In the absence of an adequate antigenic ErbB-2 peptide, I tested if bone-marrow derived DC pulsed with whole tumor lysate function as effective antigen presenting cells. The use of DC pulsed with whole tumor lysates has been shown to generate antitumor

and CTL responses (8-10). In a preliminary study, lymphocytes were collected from mice vaccinated with pCMV/cytE2A and GM-CSF and challenged with D2F2/E2 tumor cells. DCs were generated from mouse bone marrow cells and pulsed with whole D2F2/E2 cell lysates as described (11). One irradiated pulsed DC per 20 lymphocytes were cultured for 7 days in RPMI supplemented with 10% heat inactivated fetal calf serum. DC pulsed with lysate of native D2F2 cells was used as a negative control. A standard chromium release assay was performed using D2F2/E2 as target cells. Specific lysis of D2F2/E2 cells was induced from an animal which rejected tumor by CTL after stimulation *in vitro* with DC + D2F2/E2 lysate. Less killing was seen in CTL stimulated with DC + D2F2 lysate (Figure 6A). Cells from a tumor-bearing animal did not lyse D2F2/E2 cells (Figure 6B). These results indicated the feasibility of amplifying CTL *in vitro* by stimulating with tumor loaded DC.

### 3.3 Modification of pCMV/cytE2A to contain IL-2

The positive results obtained from co-vaccination with IL-2 plasmid indicated that co-vaccination is an efficacious strategy. A plasmid containing both cytE2A and IL-2 genes will be constructed only if contradictory results are observed.

### 3.4 Generation of adenoviral vector with cytE2A and verification of protein expression.

A recombinant adenovirus containing wild-type ERBB-2 has been constructed by the Adenovirus Core Facility, Wayne State University. Initial attempts to infect 3T3 or D2F2 cells by flow cytometry have not resulted in ErbB-2 expression. Further attempts will be made to infect cells and detect surface ErbB-2 expression.

## KEY RESEARCH ACCOMPLISHMENTS

- DNA vaccines encoding recombinant ERBB-2 and cytoplasmic ERBB-2 lacking tyrosine kinase activity were generated
- Anti-ErbB-2 antibody was induced by vaccination with transmembrane but not cytoplasmic ERBB-2
- Anti-tumor immunity was induced by vaccination with DNA encoding transmembrane but not cytoplasmic ERBB-2
- Anti-tumor immunity was induced when mice were vaccinated with both cytE2A and IL-2 or GM-CSF genes although an antibody response was not induced

## REPORTABLE OUTCOMES

Wei, W. Z., Shi, W. P., Galy, A., Lichlyter, D., Hernandez, S., Groner, B., Heilbrun, L., and Jones, R. F.; (1999): Protection against mammary tumor growth by vaccination with full-length, modified human ErbB-2 DNA. *Int.J.Cancer* 81, 1-7.

Pilon, S., Kelly, C., Marriott, E., and Wei, W.Z.; (1999): Protection against mammary tumor growth by vaccination with recombinant ERBB-2 DNA encoding transmembrane or cytoplasmic protein. *The Faseb Journal* 13, A645.

## CONCLUSIONS

Native ErbB-2 is a transmembrane protein with tyrosine kinase activity. To induce ErbB-2 specific CTL, a recombinant cytoplasmic ErbB-2 which lacks kinase activity was constructed. This recombinant protein localizes in the cytoplasm and is rapidly degraded by the proteasome. Vaccination with vector encoding cytE2A does not protect against challenge with an ErbB-2 expressing tumor which may be due to a lack of CD4 T cell induction. To activate or replace the need for ErbB-2 specific CD4 T cells, co-vaccination of cytE2A with cytokine genes was examined. Co-vaccination of cytE2A with either IL-2 or GM-CSF genes induced an effective anti-tumor immune response. These results indicate the processing and presentation of ErbB-2 antigenic epitopes from cytoplasmic ErbB-2 and that IL-2 or GM-CSF can substitute CD4 co-stimulation generated from transmembrane ErbB-2.

## Acronym and Symbol Definition

APC	Antigen presenting cell
CFA	Complete Freund's Adjuvant
CTL	Cytotoxic T cell
cytE2A	ERBB-2 lacking ER signal sequence and lacking tyrosine kinase activity
DC	Dendritic cell
E2A	ERBB-2 lacking tyrosine kinase activity
ER	Endoplasmic reticulum
ErbB-2	Transmembrane protein
ERBB-2	Gene encoding transmembrane protein ERBB-2
GM-CSF	Granulocyte-macrophage colony stimulating factor
i.m.	intramuscular
i.p.	intraperitoneal
IFA	Incomplete Freund's Adjuvant
IL-2	Interleukin 2
MHC	Major histocompatibility complex
MFI	Mean Fluorescence Intensity
s.c.	subcutaneous

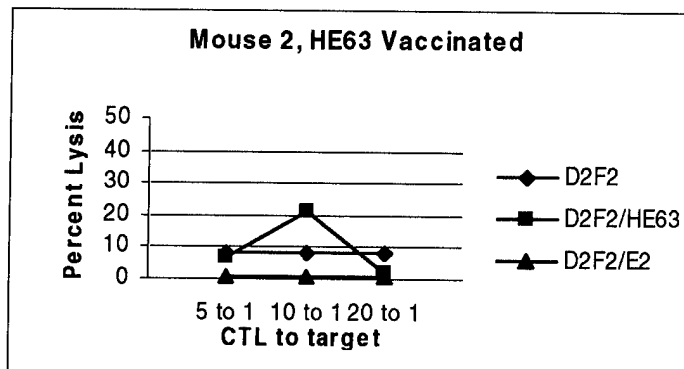
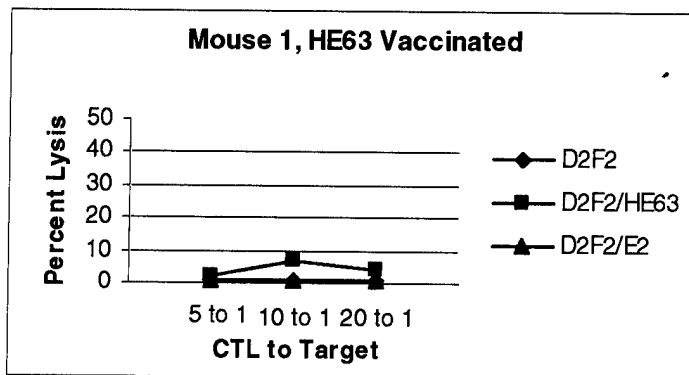

**Figure 1 CTL induction by HE63 peptide.** Mice were vaccinated three times at two week intervals s.c. with 100 ug/ml HE63 peptide in CFA in the first injection followed by the same peptide in IFA in the next two injections. Lymphocytes were removed one week after final injection and stimulated two times *in vitro* with peptide coated DC. CTL activity was measured in a standard chromium release assay. D2F2, D2F2 pulsed with 125ug/ml of HE63 peptide, and D2F2/E2 cells were the targets.

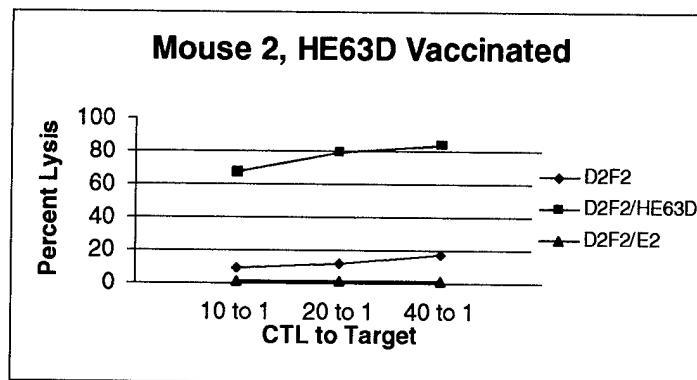
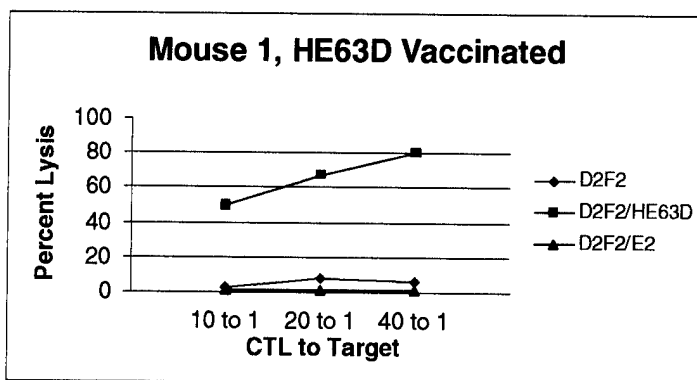

**Figure 2 CTL induction by HE63D peptide.** Mice were vaccinated three times at two week intervals s.c. with 100 ug/ml HE63D peptide as described above. Immune lymphocytes were tested against D2F2, D2F2 pulsed with 125ug/ml of HE63D peptide, and D2F2/E2 cells.

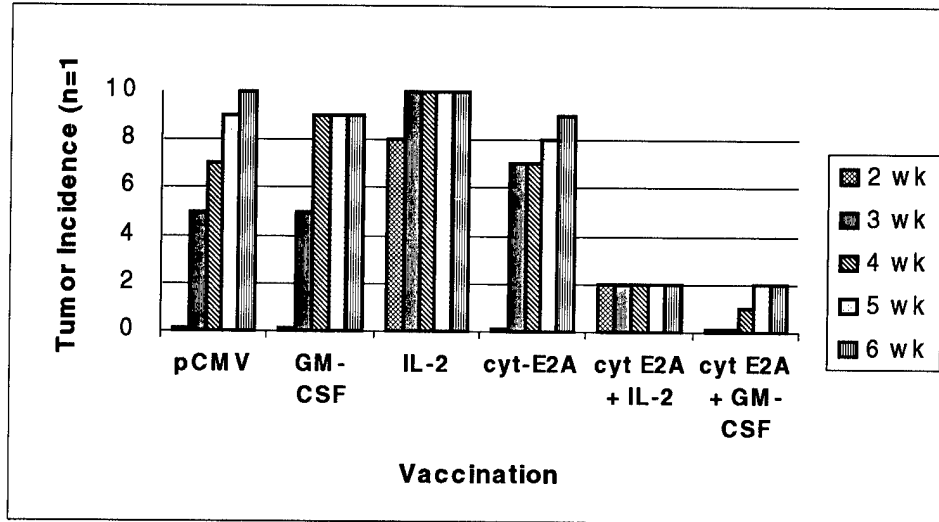

**Figure 3. Tumor rejection induced by vaccination with pCMV/cytE2A.** Mice were vaccinated 3 times at two week intervals with 100  $\mu$ g of DNA constructs. Two weeks after vaccination, mice were challenged with  $2 \times 10^5$  D2F2/E2. Tumor incidence was measured weekly by palpation.

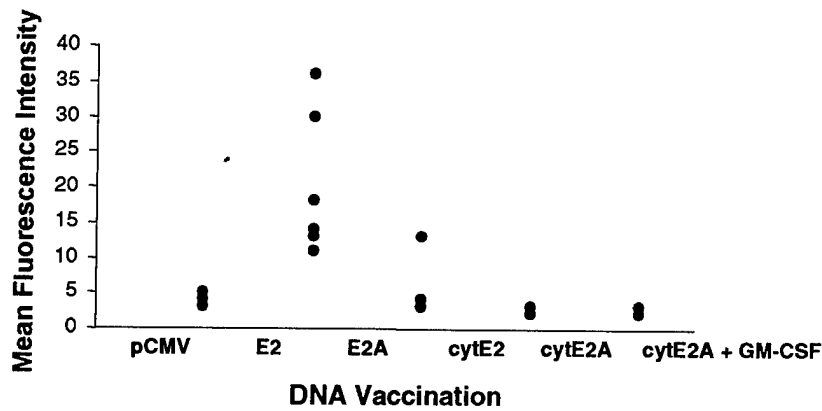

**Figure 4A. Anti-ErbB-2 antibodies induced by DNA Vaccination.** BALB/C mice (n=8) were immunized 3 times at two week intervals with 100 $\mu$ g of the following ERBB-2 DNA: E2, E2A, cytE2, cytE2A or cytE2A + GM-CSF. Sera was collected after the third vaccination. Anti-ErbB-2 IgG antibody was measured by binding to SKBR3 cells using flow cytometry. The results are expressed as mean fluorescence intensity.

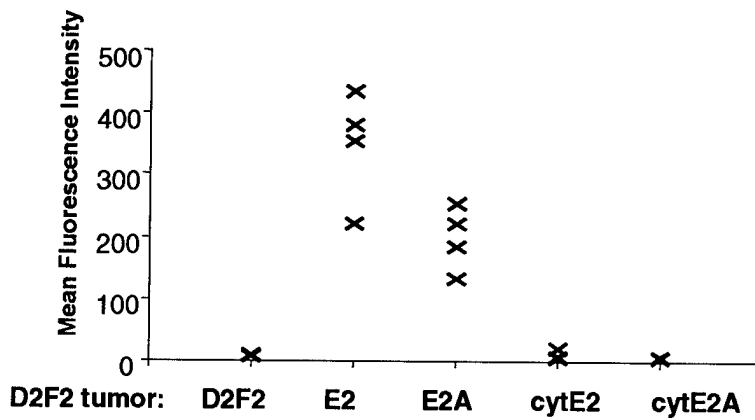

**Figure 4B. Antibody production induced by D2F2 tumor growth.** BALB/C mice (n=4) were injected with  $2 \times 10^5$  D2F2 tumor cells expressing one of the mutant ErbB-2. Sera was collected four weeks after tumor injection and IgG antibody was measured as described above.

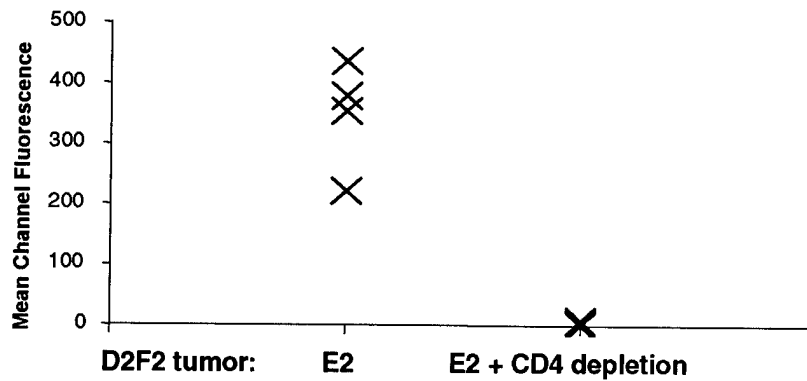

**Figure 5.** Mice were injected i.p. with anti-CD4 monoclonal antibody, GK1.5, six days prior to injection with  $2 \times 10^5$  D2F2/E2 cells. CD4 depletion was verified by flow cytometry. The CD4 depleted state was verified using lymph node cells from treated mice and was maintained by i.p. injections of GK1.5 every 3 days. Sera was collected four weeks after tumor challenge and anti-ErbB-2 antibodies were measured. Control mice received no antibody.

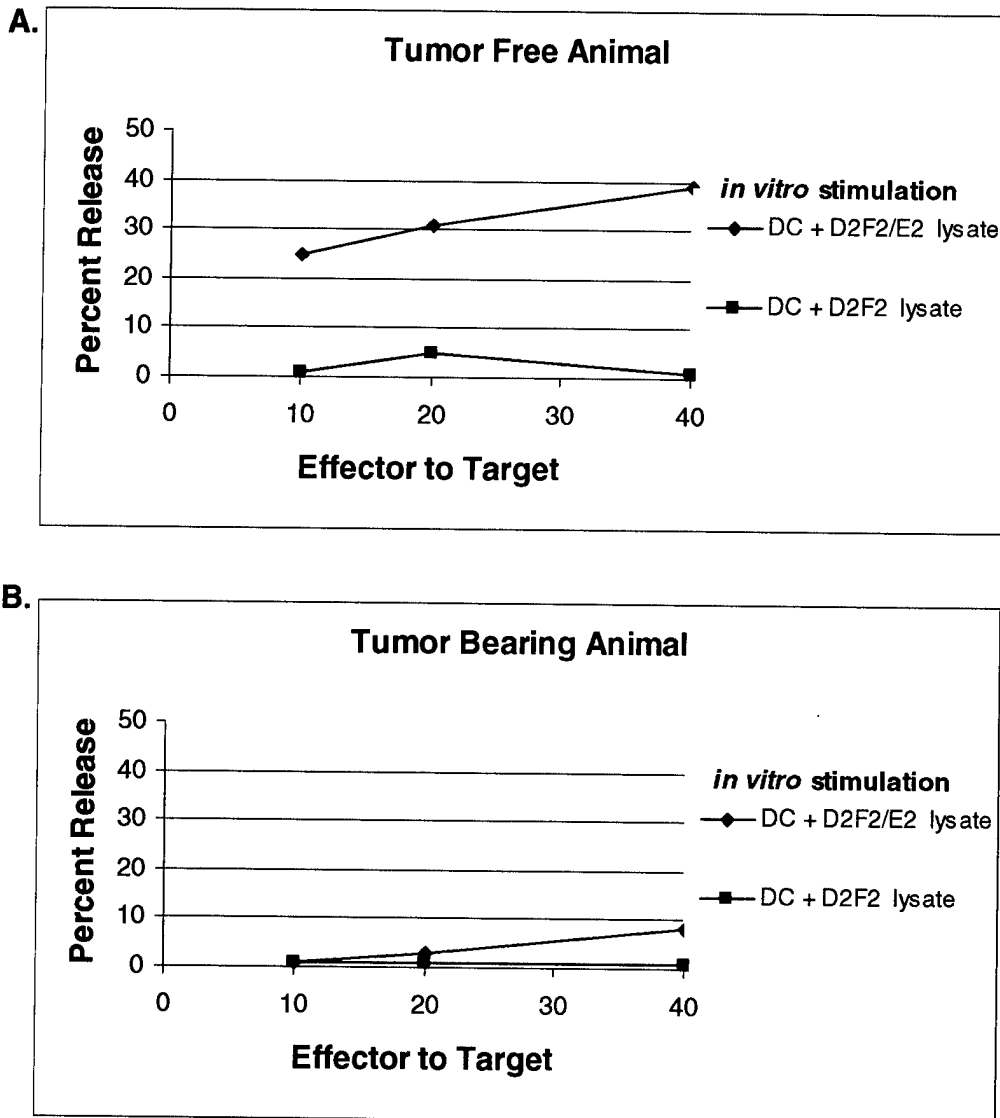

**Figure 6.** Mice received three i.m. DNA vaccinations with 100  $\mu$ g pCMV/cytE2A + 100  $\mu$ g pEFBos/GM-CSF at two week intervals. Mice were challenged with  $2 \times 10^5$  D2F2/E2 cells. Lymph nodes and spleens were collected 6 weeks after tumor challenge from one tumor-free and one tumor bearing mouse. DC were pulsed with whole cell lysates of D2F2 or D2F2/E2 and used as stimulators. Lymphocytes were cultured in RPMI supplemented with 10% fetal calf serum. CTL activity was measured at day 7. D2F2/E2 tumors were used as target cells.

## Reference List

1. Nagata, Y, Furugen, R, Hiasa, A, Ikeda, H., Ohta, N., Furukawa, K., Nakamura, H., Furukawa, K., Kanematsu, T., and Shiku, H.; (1997): Peptides derived from a wild-type murine proto-oncogene c-erbB-2/HER2/neu can induce CTL and tumor suppression in syngeneic hosts. *Journal of Immunology* 159, 1336-1343.
2. Bacik, I., Snyder, H. L., Anton, L. C., Russ, G., Chen, W, Bennink, J. R., Urge, L., Otvos, L., Dudkowska, B., Eisenlohr, L., and Yewdell, J. W.; (1997): Introduction of a glycosylation site into a secreted protein provides evidence for an alternative antigen processing pathway: Transport of precursors of major histocompatibility complex class I-restricted peptides from the endoplasmic reticulum to the cytosol. *J.Exp.Med.* 186, 479-487.
3. Okada, E., Sasaki, S., Ishii, N., Aoki, I., Yasudu, T., Nishioka, K., Fukushima, J., Miyazaka, J., Wahren, B., and Okuda, K.; (1997): Intranasal immunization of a DNA vaccine with IL-12- and Granulocyte-Macrophage Colony-Stimulating Factor (GM-CSF)-expressing plasmids in liposomes induces strong mucosal and cell-mediated immune responses against HIV-1 antigens. *Journal of Immunology* 159, 3638-3647.
4. Rosenberg, SA; (1991): Immunotherapy and Gene Therapy of Cancer. *Cancer Research* 51, 5074s-5079s.
5. Huefler, C, Koch, F, and Schuler, G; (1987): GM-CSF and IL-1 mediate the maturation of murine epidermal Langerhans cells into potent immunostimulatory dendritic cells. *J.Exp.Med.* 167, 700-705.
6. Wei, W. Z., Shi, W. P., Galy, A., Lichlyter, D., Hernandez, S., Groner, B., Heilbrun, L., and Jones, R. F.; (1999): Protection against mammary tumor growth by vaccination with full-length, modified human ErbB-2 DNA. *Int.J.Cancer* 81, 1-7.
7. Inaba, K, Inaba, M., Romani, N., Aya, H., Deguchi, M., Ikehara, S., Muramatsu, S., and Steinman, R.; (1992): Generation of large numbers of dendritic cells from mouse bone marrow cultures supplemented with granulocyte/macrophage colony-stimulating factor. *J.Exp.Med.* 176, 1693-1702.
8. Fields, R. C., Shimizu, K., and Mule, J. J.; (1998): Murine dendritic cells pulsed with whole tumor lysates mediate potent anti-tumor immune responses *in vitro* and *in vivo*. *Proc.Natl.Acad.Sci.USA* 95, 9482-9487.
9. Nair, S. K., Snyder, D, Rouse, B. T., and Gilboa, E; (1997): Regression of tumors in mice vaccinated with professional antigen-presenting cells pulsed with tumor extracts. *Int.J.Cancer* 70, 706-715.
10. Yang, S., Darrow, T. L., Vervaert, C. E., and Seigler, H. F.; (1997): Immunotherapeutic Potential of Tumor antigen-pulsed and unpulsed dendritic cells generated from murine bone marrow. *Cellular Immunology* 179, 84-95.
11. Cohen, P. A., Cohen, P. J., Rosenberg, SA, and Mule, J. J.; (1994): CD4+ T-cells from mice immunized to syngeneic sarcoma recognize distinct non-shared tumor antigens. *Cancer Research* 54, 1055-1058.

APPENDIX A

## PROTECTION AGAINST MAMMARY TUMOR GROWTH BY VACCINATION WITH FULL-LENGTH, MODIFIED HUMAN *ErbB-2* DNA

Wei-Zen WEI<sup>1\*</sup>, Wei-Ping SHI<sup>1</sup>, Anne GALY<sup>1</sup>, Darcy LICHLYTER<sup>1</sup>, Sonia HERNANDEZ<sup>1</sup>, Bernd GRONER<sup>2</sup>, Lance HEILBRUN<sup>1</sup> and Richard F. JONES<sup>1</sup>

<sup>1</sup>Breast Cancer Program, Karmanos Cancer Institute, Wayne State University, Detroit, MI, USA

<sup>2</sup>Georg-Speyer-Haus, Institute for Biomedical Research, Frankfurt, Germany

***ErbB-2* is overexpressed in several human cancers and conveys a transforming activity that is dependent on tyrosine kinase activity. Antibodies and T cells to *ErbB-2* have been isolated from cancer patients, indicating *ErbB-2* as a potential target of active vaccination. In this study, 3 mutant *ErbB-2* DNA constructs encoding full-length, *ErbB-2* proteins were tested as tumor vaccines. To eliminate tyrosine kinase activity, the ATP binding lysine residue 753 was substituted with alanine by replacing codon AAA with GCA in mutant *ErbB-2A*. To direct recombinant *ErbB-2* to the cytoplasm where major histocompatibility complex (MHC) I peptide processing takes place, the endoplasmic reticulum (ER) signal sequence was deleted in *cyt ErbB-2*. The third construct *cyt ErbB-2A* contained cytoplasmic *ErbB-2* with the K to A mutation. Expression of recombinant proteins was measured by flow cytometry in transfected murine mammary tumor cell line D2F2. Transmembrane *ErbB-2* and *ErbB-2A* were readily detected. Cytoplasmic *ErbB-2* and *ErbB-2A* were detected only after the transfected cells were incubated overnight with a proteasome inhibitor, indicating prompt degradation upon synthesis. *ErbB-2* autophosphorylation was eliminated by the K to A mutation as demonstrated by Western blot analysis. Growth of *ErbB-2*-positive tumor in BALB/c mice was inhibited after vaccination with *ErbB-2* or *ErbB-2A*, but not with *cyt ErbB-2* or *cyt ErbB-2A*. *ErbB-2A* that is free of tyrosine kinase activity is a potential candidate for anticancer vaccination. The 3 mutant constructs should be useful tools to delineate the role of individual immune effector cell in *ErbB-2*-specific antitumor immunity and to develop strategies for enhancing such immunity. Int. J. Cancer 81:748–754, 1999.**

© 1999 Wiley-Liss, Inc.

*ErbB-2* is a receptor tyrosine kinase of the *ErbB* growth factor receptor family and is overexpressed in several human cancers including breast, ovarian and lung cancer (reviewed by Tzahar and Yarden, 1998). *ErbB-2* forms heterodimer with *ErbB-1* to interact with epidermal growth factor (EGF) (Wada *et al.*, 1990) or *ErbB-3/ErbB-4* to interact with Neu differentiation factor (NDF; heregulin) (Pinkas-Kramarski *et al.*, 1996) and is indicated as the preferred subunit of the high-affinity heterodimeric receptors for both EGF and NDF. After *ErbB* receptor dimerization and tyrosine autophosphorylation, docking sites for cytoplasmic signaling molecules are generated and recruitment of second signaling molecules is initiated. Amplification or overexpression of *ErbB-2* leads to enhanced MAP kinase activity and cell proliferation, and contributes to the aggressive behavior of the tumor cells (Ben-Levy *et al.*, 1994).

*ErbB-2* is a potential target of cancer immunotherapy. Anti-*ErbB-2* antibodies have been detected in breast cancer patients (Disis *et al.*, 1994). Anti-*ErbB-2* cytotoxic T lymphocytes (CTL) have been isolated from breast and ovarian cancer patients (Ioannides *et al.*, 1993; Peoples *et al.*, 1995). Several HLA-A2.1-associated *ErbB-2* peptides have been defined and peptide-specific T cells can be generated *in vitro* (Fisk *et al.*, 1997; Yoshino *et al.*, 1994; Lustgarten *et al.*, 1997). These findings indicate the activation of anti-*ErbB-2* immune effector mechanism in cancer patients and the potential benefit of enhancing such immune reactivity.

In a phase II trial, tumor regression was demonstrated in approximately 10% of patients with metastatic breast cancer and treated with a humanized anti-*ErbB-2* monoclonal antibody (MAB) 4D5 (Baselga *et al.*, 1996). Although *ErbB-2* is expressed on

normal and tumor cells, MAB 4D5 appears to exert a selective inhibitory effect on tumor cells, supporting the antitumor activity of antibodies directed to certain *ErbB-2* epitopes. Vaccination of rhesus monkeys with the extracellular domain of *ErbB-2* protein induced antitumor antibodies and T-cell proliferation (Fendly *et al.*, 1993). In rat neu transgenic mice, vaccination with plasmid DNA encoding the extracellular and transmembrane domains of the rat *neu* DNA induced protective immunity against rat neu-positive tumor (Chen *et al.*, 1998). This protective effect was enhanced by the coinjection of interleukin 2 (IL-2) DNA. This finding supports the feasibility of activating anti-*ErbB-2* immunity by DNA vaccination in hosts expressing endogenous *ErbB-2*.

Plasmid DNA is chemically defined, can be produced in large quantity and purified to homogeneity, and is relatively stable. These are important advantages when the vaccines are intended for clinical application. Immunization of animals with plasmid DNA induced both humoral and cellular immunity to viral and tumor antigens (Pardoll and Beckerieg, 1995; Ciernik *et al.*, 1996; Chen *et al.*, 1998). Plasmid DNA injected into the muscle may be transferred to hematopoietic antigen presenting cells (APC) (Corr *et al.*, 1996; Iwasaki *et al.*, 1997), which are able to provide costimulation to antigen-specific T cells.

T cells recognize peptides that are packed into a groove molded from the extracellular domain of the major histocompatibility complex (MHC) heterodimers (Davis and Bjorkman, 1988). Peptides associated with class I (Monaco, 1992) and class II MHC (Neeftjes and Ploegh, 1992) interact with T-cell receptors (TCR) on CD8 and CD4 T cells, respectively. Peptides presented by MHC II are generated from exogenous proteins or self-proteins directed to the endosomes and lysosomes. CD4 T cells contribute significantly to antitumor immunity although the mechanism is not fully defined (Armstrong *et al.*, 1997). Direct tumor killing activity is mediated by CD8 T cells that recognize MHC I-associated peptides derived from endogenous proteins after proteasomal degradation in the cytoplasm. The degraded peptides are chaperoned to the endoplasmic reticulum (ER) and translocated into the lumen where they bind to class I MHC and  $\beta 2$  microglobulin ( $\beta 2m$ ) and are transported to the cell surface. Although class I MHC-associated *ErbB-2* peptides can be detected by peptide-specific CTL on cells overexpressing *ErbB-2*, it is not clear how native *ErbB-2* enters the cytoplasm and the antigen processing pathway. Native *ErbB-2* is a transmembrane protein and is translocated into the ER during synthesis as dictated by a stretch of 21 hydrophobic amino acids or the ER signal sequence immediately following the initiation codon. If the ER signal sequence is deleted, the protein product would be released into the cytoplasm and subjected to antigen processing directly. A model antigen beta-galactosidase (beta-gal) expressed as an intracellular or membrane-bound protein generated the same immunogenic peptide that was recognized by a CTL line (Rammensee *et*

Grant sponsor: NIH; Grant numbers: R01 CA57831 and CA76340.

\*Correspondence to: Breast Cancer Program, Karmanos Cancer Institute, 110 E. Warren Avenue, Detroit, MI 48201, USA. Fax: (313) 831-7518. E-mail: weiw@karmanos.org

Received 23 July 1998; Revised 11 November 1998

*al.*, 1989). Covalent conjugation of beta-gal with ubiquitin resulted in accelerated proteasome degradation of this protein and enhanced presentation of antigenic peptides (Grant *et al.*, 1995). These results have suggested potential advantages of directing antigenic proteins to the cytoplasm. In this study, the vaccination efficacy of the transmembrane and cytoplasmic *ErbB-2* was compared.

The tyrosine kinase activity of *ErbB-2* can be eliminated when the ATP binding lysine (K) residue 753 is replaced with a non-binding alanine (A) (Ben-Levy *et al.*, 1994; Messerle *et al.*, 1994). This K to A substitution eliminated the downstream signaling events and the oncogenic activity of *ErbB-2* of either human (Messerle *et al.*, 1994) or rat (Ben-Levy *et al.*, 1994) origin. Furthermore, kinase-deficient *ErbB-2* (K>A) when coexpressed with oncogenic *ErbB-2* can inactivate the signaling activity of the oncogenic *ErbB-2*. The K>A mutant *ErbB-2* thus functions as an anti-*ErbB-2* or anti-oncogene. In this study, the vaccination efficacy of native *ErbB-2* and mutant *ErbB-2* (K>A) was tested.

#### MATERIAL AND METHODS

##### Construction of mutant *ErbB-2* expression vectors

The construction strategy and the expected protein products are illustrated in Figure 1.

##### *pCMV/ErbB-2* (*pCMV/E2*)

A 4.4 kb *Hind*III fragment was excised from *pSV2/ErbB-2* (provided by Dr. M.C. Hung, M.D. Anderson Cancer Institute, Houston, TX) and inserted into the expression vector *pCMV5* (provided by Dr. D.W. Russell, University of Texas, Southwestern Medical Center, Dallas) to generate *pCMV/ErbB-2* (*pCMV/E2*). Transcription of *ErbB-2* is under the control of a CMV promoter/enhancer.

##### *pCMV/cyt ErbB-2* (*pCMV/cyt E2*)

To delete the ER signal sequence from *pCMV/E2*, a polymerase chain reaction (PCR) strategy was used and a recombinant cytoplasmic *ErbB-2* was generated (Fig. 1*b*). The first 397 bp of the protein coding region excluding the ER signal sequence was

amplified using the high-fidelity DNA polymerase Pfu (Stratagene, La Jolla, CA). The upper primer  $\alpha$ , 5'-GAGCACCATGAGCAC-CCAAGTGTGC-3', is homologous to the Kozak consensus ribosome binding site (Kozak, 1986), the initiation codon ATG and 15 bp immediately downstream from the ER signal sequence, but excludes the 63 bp signal sequence itself. The lower primer  $\beta$ , 3'-CAAGATCTCTGTGAGGCT TCGAA-5', is homologous to bp 441-459, which contains a naturally occurring *Bst*BI site. This PCR product was digested with *Bst*BI and used to replace the corresponding region in *pCMV/E2* to generate the plasmid *pCMV/cyt ErbB-2* (*pCMV/cyt E2*). The recombinant *cyt ErbB-2* is expected to direct the synthesis of a cytoplasmic protein. The correct sequence of *cyt ErbB-2* insert was verified by 2 independent sequencing analyses using automatic DNA sequencers at the Macromolecular Core Facility of Karmanos Cancer Institute and at the DNA sequencing facility of the Center for Molecular Medicine and Genetics, Wayne State University.

##### *pCMV/ErbB-2* (*pCMV/E2A*) or *pCMV/cyt ErbB-2A* (*pCMV/cyt E2A*)

A recombinant vector *pL-HER2VEK753A* was previously reported and contains nucleotide substitution at position 2257-2258 to convert a lysine (AAA) to an alanine (GCA) residue (Messerle *et al.*, 1994). A 398 bp fragment containing the mutated codon 753 was excised from *pL-HER2VEK753A* by restriction digestion with *AC*CIII and *Sac*II and used to replace the corresponding fragment in *pCMV/E2* and *pCMV/cyt E2*. The correct sequence of *pCMV/E2A* and *pCMV/cyt E2A* was verified by automatic DNA sequencing using both 5' and 3' primers.

##### Cell lines

Mouse mammary tumor (MMT) line D2F2 was cloned from a spontaneous mammary tumor that arose in a BALB/c hyperplastic alveolar nodule (HAN) line D2 (Mahoney *et al.*, 1985). Human breast cancer cell line SKBR-3 was purchased from the ATCC (Rockville, MD). The cell line was maintained *in vivo* in Dulbecco's modified Eagle's medium (MEM) supplemented with 5% heat-inactivated fetal bovine serum (Hyclone, Logan, UT), 10%

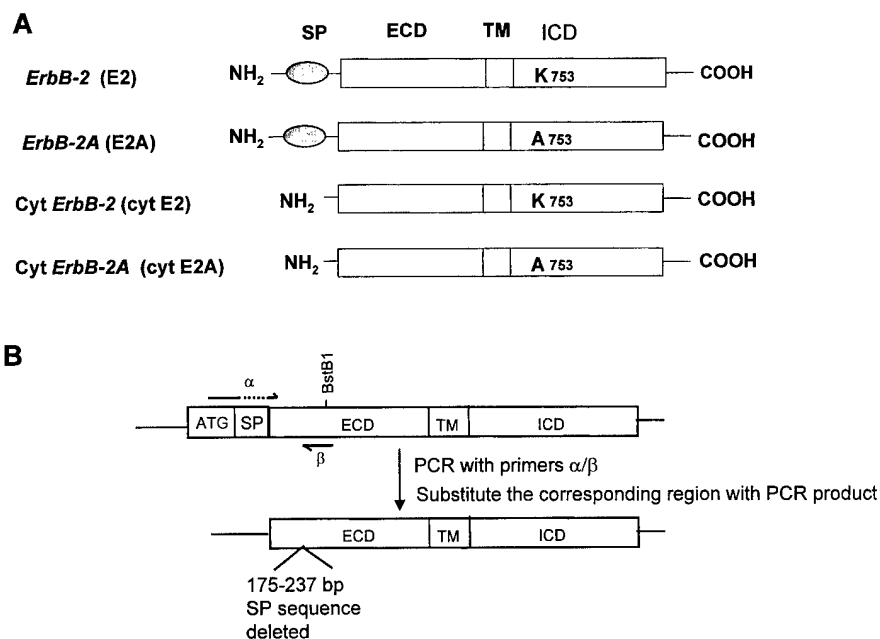

**FIGURE 1**—(a) Schematic representation of recombinant human *ErbB-2* constructs. SP, ER signal peptide; ECD, extracellular domain; TM, transmembrane domain; ICD, intracellular domain. *ErbB-2* (E2) is the wild-type human *ErbB-2*; *ErbB-2A* (E2A) has a mutation in the tyrosine kinase domain substituting alanine for lysine at codon 753; *Cyt ErbB-2* (cyt E2) has truncated ER signal peptide sequence. *Cyt ErbB-2A* (cyt E2A) has ER signal peptide deletion and the lysine to alanine substitution. (b) Deletion of ER signal peptide sequence by a PCR-based strategy.

NCTC 109 medium (Sigma, St. Louis, MO), 8 µg/ml bovine crystalline insulin (Sigma), 1 mM oxalacetic acid, 0.5 mM sodium pyruvate, 2 mM L-glutamate, 0.1 mM MEM non-essential amino acids, 100 units/ml penicillin and 100 µg/ml streptomycin.

#### Establishment of D2F2 cells expressing ErbB-2 proteins

D2F2 cells were grown in 48-well plates until they reached approximately 70% confluence and were transfected using the calcium phosphate transfection system or LipofectAMINE from GIBCO BRL (Gaithersburg, MD). The cells were cotransfected with pRSV/neo and one of the following vectors: pCMV/E2, pCMV/E2A, pCMV/cyt E2 or pCMV/cyt E2A. Transfected cells were selected in medium containing 600–1,000 µg/ml of G418 (Geneticin; Sigma) starting 48 hr after transfection. Expression of the recombinant proteins by the transfected cells from individual wells was tested by flow cytometry and cells from positive wells were subjected to 2 rounds of cloning by limiting dilution.

#### Treatment with proteasome inhibitors

Proteasome inhibitor N-acetyl-leu-leu-norleucinal (LLnL) and the very weak inhibitor N-acetyl-L-leuciny-L-leuciny-L-methional (LLM) were purchased from Sigma. To block proteasome activity, the cells were incubated with the inhibitors at the indicated concentrations at 37°C for 16–18 hr before analysis.

#### Flow cytometric analysis

The MAbs TA-1 and 3B5, which recognize the extracellular and cytoplasmic domains of ErbB-2, respectively, were purchased from Oncogene Research Products (Cambridge, MA). Fluorescein isothiocyanate (FITC)-conjugated goat anti-mouse IgG was the secondary antibody (Jackson ImmunoResearch, West Grove, PA). To detect the cytoplasmic domain of *ErbB-2*, cells were washed with serum-free medium and fixed with 0.25% paraformaldehyde at 4°C for 1 hr. The cell membrane was permeabilized by incubation in 0.2% Tween 20 at 37°C for 20 min. The fixed and permeabilized cells were stained with MAb 3B5 and FITC-conjugated goat anti-mouse IgG. Normal mouse Ig or isotype matched MAb were used as negative controls. Flow cytometric analysis was performed with a FACscan (Becton Dickinson, Mountain View, CA).

#### Immunoprecipitation and Western blot analysis

Single cell suspensions were prepared from monolayer cultures by trypsin digestion, washed twice with ice-cold PBS and lysed on ice for 60 min with modified RIPA buffer containing protease inhibitors (50 mM Tris-HCl, pH 7.4, 1% NP-40, 0.25% sodium deoxycholate, 150 mM NaCl, 1 mM EGTA, 1 mM PMSF, 1 µg/ml aprotinin, 1 µg/ml leupeptin, 1 µg/ml pepstatin, 1 mM Na<sub>3</sub>VO<sub>4</sub> and 1 mM NaF). After clearing the lysate by centrifugation at 16,000g for 10 min at 4°C, protein concentrations in the supernatant were determined with a modified Lowry assay (Bio-Rad, Hercules, CA). ErbB-2 protein was immunoprecipitated from the cell lysates by incubation with rabbit anti-ErbB-2 antibody C18 (Santa Cruz Biotechnology, Santa Cruz, CA) at 4°C for 16–18 hr, followed by incubation at 4°C for 16–18 hr with goat polyclonal antibodies to rabbit Igs pre-conjugated to protein A/G agarose (Santa Cruz Biotechnology). After extensive washing in RIPA buffer, the proteins were eluted from their immune complexes by heating to 95°C in reducing loading buffer. After fractionation by 7.5% SDS-PAGE, the proteins were electrotransferred to the nitrocellulose membrane. The membranes were blocked with 5% non-fat milk in Tris-HCl buffer. ErbB-2 was detected by immunoblotting with C18. Tyrosine phosphorylated ErbB-2 was detected with RC20 MAb, which recognizes phosphorylated tyrosine (Transduction Lab., Lexington, KY). The primary antibody was used at the concentration of 2.5 µg/ml. Peroxidase-conjugated horse anti-mouse IgG at 2 µg/ml (Vector, Burlingame, CA) was the secondary antibody and bound antibodies were visualized by chemiluminescence using the ECL Western blotting kit (Amersham, Arlington Heights, IL).

#### Tumor growth inhibition by DNA vaccination

Female BALB/c mice at 6 weeks of age were divided into 5 groups. Each group received intramuscular (i.m.) injection in the thigh with the plasmid vaccine of pCMV, pCMV/E2, pCMV/E2A, pCMV/cyt E2 or pCMV/cyt E2A prepared with the Mega kit (Qiagen, Chatsworth, CA). The plasmid DNA was administered 3 times at 2-week intervals, each time with 100 µl of saline containing 100 µg of DNA. At 2 weeks after the last immunization, mice were challenged subcutaneously (s.c.) on the flank with 2 × 10<sup>5</sup> mammary tumor cells D2F2/E2, which were D2F2 cells transfected with pCMV/E2. Tumor growth was monitored by weekly palpation by a trained staff member in the Karmanos Cancer Institute animal care facility who was not informed of the experimental design. Two perpendicular measurements of the tumor diameter were taken on each tumor with a caliper and the average was recorded.

## RESULTS

#### Expression of recombinant ErbB-2 proteins

BALB/c mouse mammary tumor cell line D2F2 was transfected with pCMV/E2, pCMV/E2A, pCMV/cyt E2 or pCMV/cyt E2A and selected in media containing 600–1,000 µg/ml of G418. The production of ErbB-2 or mutant ErbB-2 proteins was measured by flow cytometry and the staining profiles of the transfected cells are shown in Figure 2. MAb TA-1 (Oncogene Research), which recognizes an extracellular epitope of ErbB-2, stained viable D2F2 cells transfected with pCMV/E2 or pCMV/E2A (Fig. 2a). Human breast cancer cell line SKBR-3, which has amplified *ErbB-2* gene, was the positive control. MAb TA-1 did not recognize native D2F2 cells, nor D2F2 cells transfected with pCMV/cyt E2 (D2F2/E2) or pCMV/cyt E2A (D2F2/E2A). Since cytoplasmic *ErbB-2* was designed to localize in the cytoplasm, surface expression was not expected.

To detect recombinant cytoplasmic protein, MAb 3B5, which recognizes a cytoplasmic epitope of ErbB-2, was used to stain the recombinant cytoplasmic proteins in the transfected cells that were fixed and permeabilized. Binding of 3B5 to the cytoplasmic portion of transmembrane ErbB-2 in D2F2/E2, D2F2/E2A and SKBR-3 cells was detected (Fig. 2b). When 20 colonies of D2F2 cells transfected with pCMV/cyt E2 were examined, none had detectable *ErbB-2* expression. A small increase of fluorescence observed after the staining with MAb 3B5 was consistently observed with non-transfected D2F2 cells and may be the result of antibody binding to endogenous mouse ErbB-2. The inability to detect the recombinant cyt ErbB-2 in the transfected cells may indicate failure of *cyt ErbB-2* gene expression or rapid protein degradation by the proteasomes. Since the cytoplasmic ErbB-2 was designed not to enter ER, they would not be glycosylated and would not fold as the native protein. They were likely recognized as defective proteins in the cytoplasm and subjected to proteasome degradation. To determine if cyt ErbB-2 or cyt ErbB-2A was degraded by the proteasome, transfected D2F2/cyt E2 or D2F2/cyt E2A cells were incubated with peptide aldehyde LLnL, which has been shown to block the chymotryptic activity of proteasomes (Rock *et al.*, 1994).

**FIGURE 2**—Expression of *ErbB-2* in BALB/c mouse mammary tumor D2F2 cells. Cells were transfected with pCMV/E2, E2A, cyt E2 or cyt E2A. Viable cells were stained with MAb TA-1, which recognizes an extracellular epitope of ErbB-2 (a,c). Expression of cytoplasmic ErbB-2 was measured with MAb 3B5 specific for a cytoplasmic epitope after the cells had been fixed in paraformaldehyde and permeabilized with Tween 20 before incubation with MAb 3B5 (b,d). To detect proteins degraded by the proteasome, cells were incubated overnight with 80 µM of LLnL before they were subjected to analysis (c,d). Clear area: staining profile with MAb TA-1 (a,c) or MAb 3B5 (b,d); shaded area: staining profile with control normal mouse IgG. The number in each figure depicts the mean channel fluorescence of the test sample stained with either TA-1 or 3B5.

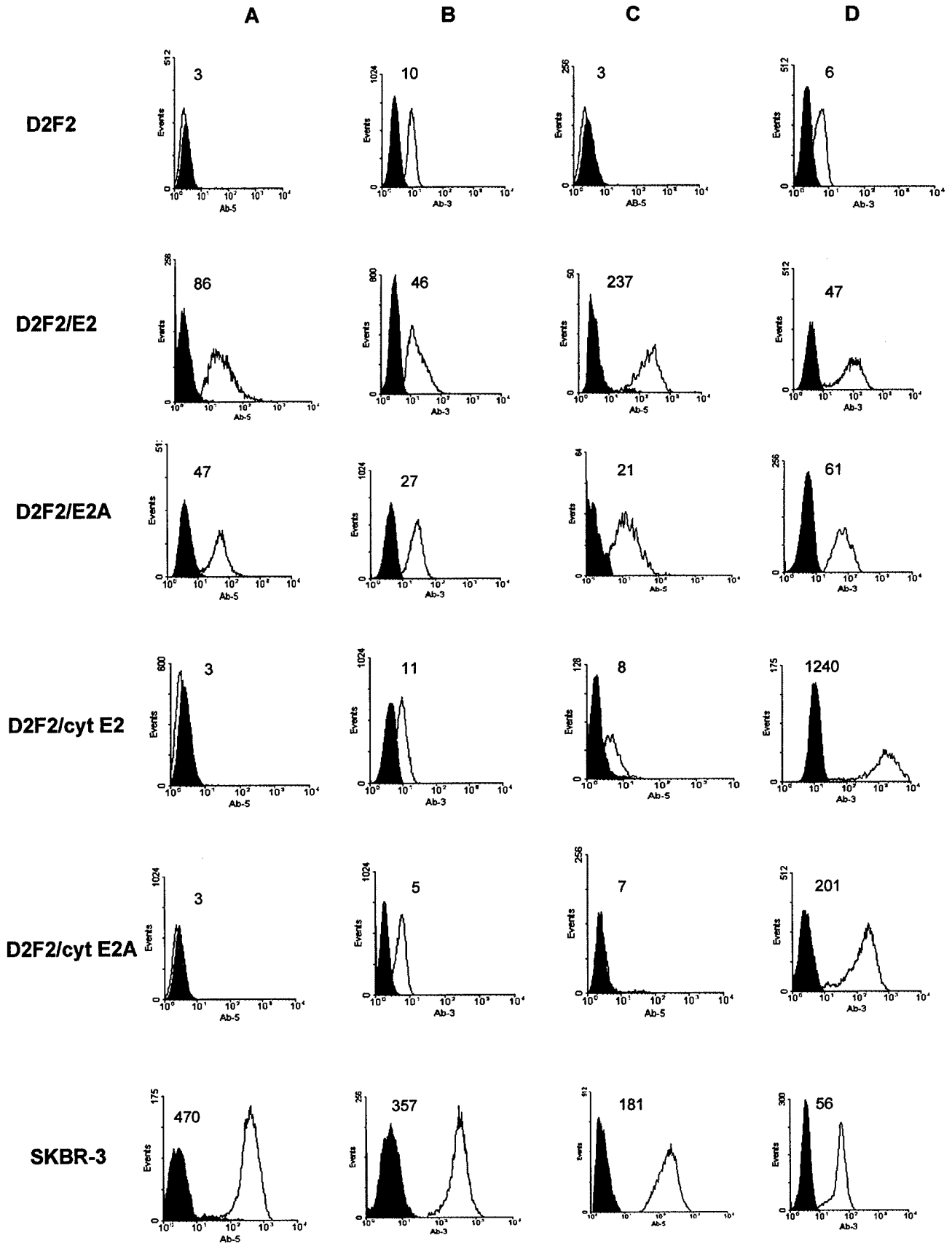

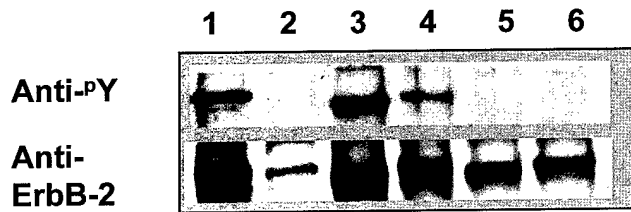

**FIGURE 3** – Tyrosine phosphorylation of mutant ErbB-2. The following cell lines were incubated overnight with 80  $\mu$ M of LLnL before lysis: SKBR-3 (lane 1), D2F2 (lane 2) and D2F2 transfected with pCMV/cyt E2 (lane 3), pCMV/E2 (lane 4), pCMV/cyt E2A (lane 5) or pCMV/E2A (lane 6). Whole cell lysates were prepared and ErbB-2 and mutant proteins were immunoprecipitated with polyclonal antibody C18. Immunoprecipitated proteins were separated by electrophoresis, transferred to nitrocellulose filter and blotted with C18 or RC20, which is directed to phosphorylated tyrosine. Bound antibody was visualized by chemiluminescence.

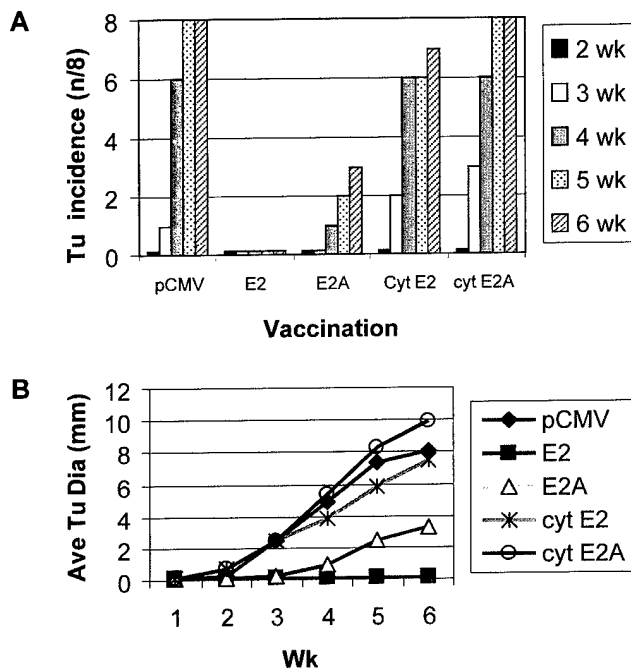

**FIGURE 4** – Induction of antitumor immunity by *ErbB-2* and mutant *ErbB-2* DNA vaccination. BALB/c mice were immunized i.m. at 2 sites in the thigh with a total volume of 100  $\mu$ l of PBS containing 100  $\mu$ g of pCMV, pCMV/E2, pCMV/E2A, pCMV/cyt E2 or pCMV/cyt E2A. The immunization was repeated twice at 2-week intervals. At 2 weeks after the last injection, mice were challenged by s.c. injection with  $1 \times 10^5$  D2F2 cells, which express wild-type human *ErbB-2*. There were 8 mice in each group. Tumor incidence was monitored weekly (a) and tumor size measured with a caliper (b).

After overnight incubation with 80  $\mu$ M of LLnL, 16 of 20 colonies transfected with pCMV/cyt E2 demonstrated significant accumulation of ErbB-2 in the cytoplasm. Figure 2d shows strong staining of D2F2/cyt E2 and D2F2/cyt E2A by MAb 3B-5 after the cells had been incubated overnight with LLnL. MAb TA-1, which binds to the extracellular domain of ErbB-2, did not recognize D2F2/cyt E2 or D2F2/cyt E2A even after the cells had been incubated with LLnL (Fig. 2c). Therefore, transfection with pCMV/cyt E2 or pCMV/cyt E2A resulted in the generation of an unstable cytoplasmic protein that is quickly degraded by the proteasomes. Incubation of D2F2/E2, D2F2/E2A with LLnL did not have significant effect on

the expression of the transmembrane protein. SKBR-3 cells had reduced ErbB-2 expression after LLnL incubation and may be a result of toxicity. Treatment of transfected cells or SKBR-3 cells with the weak proteasome inhibitor LLM had no effect on the level of native or recombinant ErbB-2 protein.

#### Tyrosine phosphorylation of *ErbB-2*

To determine if the recombinant ErbB-2 exhibits tyrosine kinase activity, Western blot analysis was performed to detect phosphorylated tyrosine on the recombinant proteins. Transfected D2F2 cells were incubated overnight in the presence of 80  $\mu$ M of LLnL. Recombinant ErbB-2 proteins were immunoprecipitated from the whole cell lysates with rabbit anti-ErbB-2 antibody C18. The proteins were separated by PAGE, transferred to nitrocellulose filter and blotted with C18 or RC20 which recognized phosphorylated tyrosine. Figure 3 shows a 185 kDa protein detected in the lysates from SKBR-3, D2F2/E2 and D2F2/E2A when the membrane was blotted by anti-ErbB-2 antibody C18. The cytoplasmic ErbB-2 and ErbB-2A proteins migrated slightly faster than the transmembrane proteins, consistent with the notion that cyt ErbB-2 or cyt ErbB-2A did not enter the ER and was not, N-glycosylated. Importantly, the ErbB-2 protein isolated from D2F2 cells transfected with E2 or cyt E2 or from SKBR-3 cells was tyrosine phosphorylated and recognized by MAb RC20. On the contrary, recombinant ErbB-2A and cytoplasmic ErbB-2A were not recognized by MAb RC20, supporting the elimination of tyrosine kinase activity by the K to A substitution at residue 753. The endogenous mouse ErbB-2 in D2F2 cells was detected also by MAb C18, but showed little or no phosphorylation when stained with MAb RC20. The phosphorylation of cyt ErbB-2 indicates active kinase activity of recombinant ErbB-2 even when the protein was produced in the cytoplasm. It was only when the ATP binding lysine residue was replaced by a non-binding alanine as in ErbB-2A and cyt ErbB-2A that tyrosine kinase activity was eliminated.

#### DNA vaccination with wt and cyt ErbB-2

BALB/c mice were immunized 3 times at 2-week intervals by i.m. injection in the thigh with 100  $\mu$ g of pCMV/E2, pCMV/E2A, pCMV/cyt E2 or pCMV/cyt E2A in 0.1 ml saline. The control group received pCMV without insert. Immunized mice were challenged s.c. with  $2 \times 10^5$  D2F2 cells transfected with E2 (D2F2/E2). The results in Figure 4 show complete inhibition of tumor growth in mice vaccinated with the pCMV/E2. Protection was also observed in mice that received pCMV/E2A. The mice immunized with pCMV/cyt E2 or pCMV/cyt E2A all developed tumors except one mouse in the pCMV/cyt E2 group. The tumor size was measured by a caliper and the average diameter was calculated. The mean tumor sizes (in mm) of the 5 treatment groups at 6 weeks after tumor challenge were 8.0, 0.0, 3.3, 7.4 and 9.9 for pCMV/E2, E2A, cyt E2 and cyt E2A groups, respectively. Both the E2 and E2A groups were significantly different from the pCMV control group, both with  $p < 0.05$ , by Dunnett's multiple comparisons procedure. The remaining 3 treatment groups were statistically indistinguishable.

#### DISCUSSION

To develop DNA vaccines directed at human *ErbB-2*, 3 mutant *ErbB-2* constructs were generated and their vaccination efficacy was tested. The principle of construction was to preserve most if not all of the immunogenic epitopes and to eliminate tyrosine kinase or transforming activity of *ErbB-2*. Several immunogenic peptides presented by HLA-A2.1 have been identified, including peptides derived from the extracellular, transmembrane or cytoplasmic domain (Fisk *et al.*, 1997; Yoshino *et al.*, 1994; Lustgarten *et al.*, 1997). Vaccination with the full-length DNA has the advantage of presenting the complete repertoire of ErbB-2 epitopes in patients of any HLA haplotype. Although injected i.m., the recombinant proteins may be presented by the APCs *in vivo* according to each

individual's MHC haplotypes (Iwasaki *et al.*, 1997; Corr *et al.*, 1996). The recombinant *ErbB-2* constructs generated in this study contain the complete sequence of the mature protein with a single amino acid substitution in ErbB-2A and cyt ErbB-2A. Since mature ErbB-2 protein contains over 1,200 amino acids, a single residue substitution at position 753 should have minimal impact on the immunogenicity of this protein.

The expression of the vaccine constructs was tested by stable transfection of murine mammary tumor cell line D2F2. The transmembrane ErbB-2 and ErbB-2A were readily detected by MAb TA-1, which recognized an extracellular epitope of human ErbB-2 (Fig. 2). On the contrary, cyt ErbB-2 and cyt ErbB-2A could not be detected by MAb 3B5 specific for a cytoplasmic epitope, unless the transfected cells were incubated overnight with proteasome inhibitor LLnL, indicating prompt degradation of the recombinant cytoplasmic protein. When analyzed by Western blotting, ErbB-2 and ErbB-2A are of the same size as p185 in SKBR-3 cells. Cyt ErbB-2 and cyt ErbB-2A migrate slightly faster than their transmembrane counterparts, consistent with the lack of N-glycosylation on cytoplasmic proteins. The lack of N-glycosylation may result in unstable folding and enhanced degradation of the folded protein.

Transgenic mice expressing rat neu gave rise to spontaneous mammary tumors (Muller *et al.*, 1988; Chen *et al.*, 1998). The oncogenic activity of ErbB-2 may be a result of heterodimer formation with other members of the ErbB family and an enhanced response to the stroma-derived ligands (Tzahar and Yarden, 1998). If *ErbB-2* DNA is to be administered as a vaccine *in vivo*, it is imperative to remove the signal transducing capacity from the construct. In a previous report, substitution of the ATP binding residue lysine with a non-binding residue alanine removed tyrosine kinase and transforming activity from recombinant human *ErbB-2* (Messerle *et al.*, 1994). These findings indicate that a single autophosphorylation site confers oncogenicity of ErbB-2 receptor and enables coupling to the MAP kinase pathway (Messerle *et al.*, 1994). When examined by an independent group using rat neu, the same K to A single mutation also eliminated the signaling activity of rat neu (Ben-Levy *et al.*, 1994). Overexpression of *ErbB-2* (K>A) in 3T3 cells did not result in anchorage-independent growth (Messerle *et al.*, 1994). In fact, 3T3 cells that were transformed with an activated *ErbB-2* lost anchorage-independent growth when further transfected with *ErbB-2* (K>A), supporting the anti-oncogenic activity of *ErbB-2A*. In the current study, the tyrosine residue on ErbB-2A and cyt ErbB-2A was not phosphorylated (Fig. 3). Therefore, K>A mutation at residue 753 eliminated tyrosine kinase activity as previously described, and *ErbB-2A* and cyt *ErbB-2A* are more appropriate candidates as DNA vaccines. It

was interesting that native ErbB-2 appeared to be more potent than the K>A mutant in the induction of antitumor immunity. Whether this finding indicates an enhanced antigen presenting activity as a result of functional ErbB-2 expression remains to be determined.

When the vaccination efficacy of recombinant *ErbB-2* was tested, the transmembrane *ErbB-2* and *ErbB-2A* were far more effective than their cytoplasmic counterparts in the induction of antitumor immunity (Fig. 4). Vaccination with pcDNA3.1 (+) containing *ErbB-2* or cyt *ErbB-2* showed similar protective effect with the transmembrane but not with cytoplasmic *ErbB-2* (not shown). Since full-length p185 was generated from all recombinant *ErbB-2*, the complete protein sequence was available to the APCs from all 4 vaccines. The rapid degradation of cyt ErbB-2 and cyt ErbB-2A may even enhance the presentation of class I MHC-associated peptide antigens because accelerated degradation of model antigens was shown to enhance the presentation of class I MHC-associated peptides (Grant *et al.*, 1995). Cytoplasmic ErbB-2 may not have access to endosome and lysosome where class II MHC peptides are processed. Priming of CD8 T cells to most antigens requires CD4 T-cell help via CD40-CD40L interactions (Bennett *et al.*, 1998; Schoenberger *et al.*, 1998). Immunization with the cytoplasmic ErbB-2 and presentation of class I MHC-associated peptides without CD4 help may induce inadequate T-cell activation or even T-cell anergy. The cytoplasmic protein may not induce antibody response either. Indeed, vaccination with cyt *ErbB-2* or cyt *ErbB-2A* may be functionally equivalent to vaccination with the complete repertoire of MHC I-associated peptides. These constructs should be useful tools to delineate the immune response to antigens presented by class I MHC alone and to define conditions for modulating such immunity.

Vaccination with native ErbB-2 results in excellent antitumor immunity. The potential adverse effect of administering plasmid DNA encoding a functional oncogene may prohibit the use of this vaccine in patients. ErbB-2A when administered alone induced significant antitumor immunity and is a candidate vaccine. It is noted that this series of *ErbB-2* DNA vaccines encode a human protein and would likely induce stronger responses in mice than in humans. The goal of our study was, however, to compare the different forms of the recombinant vaccines, and the results showed the transmembrane form to be superior than the cytoplasmic form when used alone.

#### ACKNOWLEDGEMENTS

The authors thank Ms. E. Marriott for her excellent technical assistance.

#### REFERENCES

- ARMSTRONG, T.D., CLEMENTS, V.K., MARTIN, B.K., TING, J.P.Y. and OSTRAND-ROSENBERG, S., Major histocompatibility complex class II-transfected tumor cells present endogenous antigen and are potent inducers of tumor-specific immunity. *Proc. nat. Acad. Sci. (Wash.)*, **94**, 6886-6891 (1997).
- BASELGA, J. and 13 OTHERS, Phase II study of weekly intravenous recombinant humanized anti-p185<sup>her2</sup> monoclonal antibody in patients with HER2/neu-overexpressing metastatic breast cancer. *J. clin. Oncol.*, **14**, 737-744 (1996).
- BEN-LEVY, R., PATERSON, H.F., MARSHALL, C.J. and YARDEN, Y., A single autophosphorylation site confers oncogenicity to the Neu/ErbB-2 receptor and enables coupling to the MAP kinase pathway. *EMBO J.*, **13**, 3302-3311 (1994).
- BENNETT, S., CARBONE, F.R., KARAMALIS, F., FLAVELL, R.A., MILLER, J.F.A.P. and HEATH, W.R., Help for cytotoxic-T-cell responses is mediated by CD40 signalling. *Nature (Lond.)*, **393**, 478-480 (1998).
- CHEN, Y., HU, D., ELING, D.J., ROBBINS, J. and KIPPS, T.J., DNA vaccines encoding full-length or truncated Neu induce protective immunity against Neu-expressing mammary tumors. *Cancer Res.*, **58**, 1965-1971 (1998).
- CIERNIK, I.F., BERZOFKY, J.A. and CARBONE, D.P., Induction of cytotoxic T lymphocytes and antitumor immunity with DNA vaccines expressing single T cell epitopes. *J. Immunol.*, **156**, 2369-2375 (1996).
- CORR, M., LEE, D.J., CARSON, D.A. and TIGHE, H., Gene vaccination with naked plasmid DNA: mechanism of CTL priming. *J. exp. Med.*, **184**, 1555-1560 (1996).
- DAVIS, M.M. and BJORKMAN, P.J., T-cell antigen receptor genes and T-cell recognition. *Nature (Lond.)*, **334**, 395-402 (1988).
- DISIS, M., CALENOFF, E., MCLAUGHLIN, G., MURPHY, A.E., CHEN, W., GRONER, B., JESCHKE, M., LYDON, N., MCGLYNN, E., LIVINGSTON, R.B., MOE, R. and CHEEVER, M.A., Existing T cell and antibody immunity to Her-2/neu protein in patients with breast cancer. *Cancer Res.*, **54**, 16-20 (1994).
- FENDLY, B.M., KOTTS, C., WONG, W.L.T., FIGARI, I., HAREL, W., STAIB, L., CARVER, M.E., VETTERLEIN, D., MITCHELL, M.S. and SHEPARD, H.M., Successful immunization of rhesus monkeys with the extracellular domain of p185HER2: a potential approach to human breast cancer. *Vaccine Res.*, **2**, 129-139 (1993).
- FISK, B., ANDERSON, B.W., GRAVITT, K.R., O'BRIAN, C.A., KUDELKA, A.P., MURRAY, J.L., WHARTON, J.T. and IOANNIDES, C.G., Identification of

- naturally processed human ovarian peptides recognized by tumor-associated cytotoxic T lymphocytes. *Cancer Res.*, **57**, 87-95 (1997).
- GRANT, E.P., MICHALEK, M.T., GOLDBERG, A.L. and ROCK, K.L., Rate of antigen degradation by the ubiquitin-proteasome pathway influences MHC class I presentation. *J. Immunol.*, **155**, 3750-3758 (1995).
- IOANNIDES, C.G., FISK, B., FAN, D., BIDDISON, W.E., WHARTON, J.T. and O'BRIAN, C.A., Cytotoxic T cells isolated from ovarian malignant ascites recognize a peptide derived from the Her-2/neu proto-oncogene. *Cell. Immunol.*, **151**, 225-234 (1993).
- IWASAKI, A., AURORA, C., TORRES, T., OHOSHI, P.S., ROBINSON, H.L. and BARBER, B.H., The dominant role of bone marrow-derived cells in CTL induction following plasmid DNA immunization at different sites. *J. Immunol.*, **159**, 11-14 (1997).
- KOZAK, M., Point mutations define a sequence flanking the AUG initiator codon that modulates translation by eukaryotic ribosomes. *Cell*, **44**, 283-292 (1986).
- LUSTGARTEN, J., THEOBALD, M., LABADIE, C., LAFACE, D., PETERSON, P., DISIS, M.L., CHEEVER, M.A. and SHERMAN, L.A., Identification of her-2/Neu CTL epitopes using double transgenic mice expressing HLA-A2.1 and human CD.8. *Hum. Immunol.*, **52**, 109-118 (1997).
- MAHONEY, K.H., MILLER, B.E., and HEPPNER, G.H., FACS quantitation of leucine aminopeptidase and acid phosphatase on tumor associated macrophages from metastatic and nonmetastatic mouse mammary tumors. *J. Leukocyte Biol.*, **38**, 573-585 (1985).
- MESSERLE, K., SCHLEGEL, J., HYNES, N.E. and GRONER, B., NIH/3T3 cells transformed with the activated ErbB-2 oncogene can be phenotypically reverted by a kinase deficient, dominant negative ErbB-2 variant. *Mol. cell. Endocrinol.*, **105**, 1-10 (1994).
- MONACO, J.J., Pathways of antigen processing: a molecular model of MHC class-I-restricted antigen processing. *Immunol. Today*, **13**, 173-176 (1992).
- MULLER, W., SINN, E. and PATTENGAL, P., Single step induction of mammary adenocarcinoma in transgenic mice bearing the activated c-neu oncogene. *Cell*, **54**, 105-115 (1988).
- NEEFJES, J.J. and PLOEGH, H.L., Intracellular transport of MHC class II molecules. *Immunol. Today*, **13**, 179-183 (1992).
- PARDOLL, D.M. and BECKERIEG, A.M., Exposing the immunology of naked DNA vaccines. *Immunity*, **3**, 165-169 (1995).
- PEOPLES, G.E., GOEDGEBUURE, P.S., SMITH, R., LINEHAN, D.C., YOSHINO, I. and EBERLEIN, T.J., Breast and ovarian cancer-specific cytotoxic T lymphocytes recognize the same Her-2/neu-derived peptide. *Proc. nat. Acad. Sci. (Wash.)*, **92**, 432-436 (1995).
- PINKAS-KRAMARSKI, R., SOUSSAN, L., WATERMAN, H., LEVKOWITZ, G., ALROY, I., KLAPPER, L.N., LAVI, S., SEGER, R., RATZKIN, B.J., SELA, M. and YARDEN, Y., Diversification of Neu differentiation factor and epidermal growth factor signaling by combinatorial receptor interactions. *EMBO J.*, **15**, 2452-2467 (1996).
- RAMMENSEE, H.G., SCHILD, H. and THEOPOLD, U., Protein-specific cytotoxic T lymphocytes: recognition of transfectants expressing intracellular, membrane-associated or secreted forms of beta-galactosidase. *Immunogenetics*, **30**, 296-302 (1989).
- ROCK, K.L., GRAMM, C., ROTHSTEIN, L., CLARK, K., STEIN, R., DICK, L., HWANG, D. and GOLDBERG, A.L., Inhibitors of the proteasome block the degradation of most cell proteins and the generation of peptides presented on MHC class I molecules. *Cell*, **78**, 761-771 (1994).
- SCHOENBERGER, S.P., TOES, R., VAN DER VOORT, E.I.H., OFFRINGA, R. and MELIEF, C.J., T-cell help for cytotoxic T lymphocytes is mediated by CD40-CD40L interactions. *Nature (Lond.)*, **393**, 480-483 (1998).
- TZAHAR, E. and YARDEN, Y., The ErbB-2/HER2 oncogenic receptor of adenocarcinomas: from orphanhood to multiple stromal ligands. *Biochem. biophys. Acta*, **1377**, M25-M37 (1998).
- WADA, T., QIAN, X. and GREENE, M.I., Intermolecular association of the p<sup>185neu</sup> protein and EGF receptor modulates EGF receptor function. *Cell*, **61**, 1339-1347 (1990).
- YOSHINO, I., GOEDGEBUURE, P.S., PEOPLES, G.E., PARIKH, A.S., DiMAIO, J.M., LYERLY, H.K., GAZDAR, A.F. and EBERLEIN, T.J., HER-2/neu-derived peptides are shared antigens among human non-small cell lung cancer and ovarian cancer. *Cancer Res.*, **54**, 3387-3390 (1994).