

LOAN DOCUMENT

PHOTOGRAPH THIS SHEET

①

INVENTORY

DTIC ACCESSION NUMBER

LEVEL

Bioventing Pilot Test Work Plan for Spill Site No. 1
DOCUMENT IDENTIFICATION
Feb 96

DISTRIBUTION STATEMENT A
Approved for Public Release
Distribution Unlimited

DISTRIBUTION STATEMENT

ACCESSION FOR	
NTIS	GRAM <input checked="" type="checkbox"/>
DTIC	TRAC <input type="checkbox"/>
UNANNOUNCED JUSTIFICATION <input type="checkbox"/>	
BY	
DISTRIBUTION/	
AVAILABILITY CODES	
DISTRIBUTION	AVAILABILITY AND/OR SPECIAL
A-1	

DISTRIBUTION STAMP

DATE ACCESSIONED

DATE RETURNED

20001121 058

DATE RECEIVED IN DTIC

REGISTERED OR CERTIFIED NUMBER

PHOTOGRAPH THIS SHEET AND RETURN TO DTIC-FDAC

H
A
N
D
L
E

W
I
T
H

C
A
R
E

DRAFT

**Bioventing Pilot Test Work Plan for
Spill Site No. 1, Building 457 Area, and UST 702**



**Eaker Air Force Base
Blytheville, Arkansas**

Prepared For

**Air Force Center for Environmental Excellence
Brooks Air Force Base, Texas**

and

**Air Force Base Conversion Agency/OL-J
Eaker Air Force Base, Arkansas**

February 1996



**PARSONS
ENGINEERING SCIENCE, INC.**

1700 Broadway, Suite 900 • Denver, Colorado 80290

AQ M01-02-0233

DEFENSE TECHNICAL INFORMATION CENTER REQUEST FOR SCIENTIFIC AND TECHNICAL REPORTS

Title AFCEE Collection

1. Report Availability (Please check one box)	2a. Number of Copies Forwarded	2b. Forwarding Date

each July/2000

2c. Distribution Statement (Please check ONE box)

DoD Directive 5230.24, "Distribution Statements on Technical Documents," 18 Mar 87, contains seven distribution statements, as described briefly below. Technical documents MUST be assigned a distribution statement.

DISTRIBUTION STATEMENT A: Approved for public release. Distribution is unlimited.

DISTRIBUTION STATEMENT B: Distribution authorized to U.S. Government Agencies only.

DISTRIBUTION STATEMENT C: Distribution authorized to U.S. Government Agencies and their contractors.

DISTRIBUTION STATEMENT D: Distribution authorized to U.S. Department of Defense (DoD) and U.S DoD contractors only.

DISTRIBUTION STATEMENT E: Distribution authorized to U.S. Department of Defense (DoD) components only.

DISTRIBUTION STATEMENT F: Further dissemination only as directed by the controlling DoD office indicated below or by higher authority.

DISTRIBUTION STATEMENT X: Distribution authorized to U.S. Government agencies and private individuals or enterprises eligible to obtain export-controlled technical data in accordance with DoD Directive 5230.25, Withholding of Unclassified Technical Data from Public Disclosure, 6 Nov 84.

2d. Reason For the Above Distribution Statement (in accordance with DoD Directive 5230.24)

2e. Controlling Office	2f. Date of Distribution Statement Determination
<u>HQ AFCEE</u>	<u>15 Nov 2000</u>

3. This report is NOT forwarded for the following reasons. (Please check appropriate box)

It was previously forwarded to DTIC on (date) and the AD number is

It will be published at a later date. Enter approximate date if known.

In accordance with the provisions of DoD Directive 3200.12, the requested document is not supplied because:

Print or Type Name	Signature
<u>Laura Peña</u>	<u>Laura Peña</u>
Telephone	(For DTIC Use Only) AQ Number
<u>210-536-1431</u>	<u>11-02-0233</u>

DRAFT
BIOVENTING PILOT TEST WORK PLAN FOR
SPILL SITE NO. 1, BUILDING 457 AREA, AND UST 702

EAKER AIR FORCE BASE
BLYTHEVILLE, ARKANSAS

Prepared for:

Air Force Center for Environmental Excellence
Brooks AFB, Texas

and

Air Force Base Conversion Agency/OL-J
Eaker AFB, Arkansas

February 1996

Prepared by:

Parsons Engineering Science, Inc.
1700 Broadway, Suite 900
Denver, Colorado 80290

TABLE OF CONTENTS

	<u>Page</u>
1.0	Introduction 1
2.0	Site Description 2
2.1	Spill Site No. 1 2
2.1.1	Site Location and History 2
2.1.2	Site Geology and Hydrology 2
2.1.3	Site Contaminants 5
2.2	Building 457 Area 5
2.2.1	Site Location and History 5
2.2.2	Site Geology and Hydrology 8
2.2.3	Site Contaminants 8
2.3	UST 702 11
2.3.1	Site Location and History 11
2.3.2	Site Geology and Hydrology 11
2.3.3	Site Contaminants 11
3.0	Pilot Test Activities 11
3.1	Test Design for Spill Site No. 1 13
3.1.1	Vent Well Installation 13
3.1.2	Monitoring Point Installations 15
3.2	Test Design for Building 457 Area 15
3.2.1	Vent Well Installation 19
3.2.2	Monitoring Point Installations 19
3.3	Test Design for UST 702 19
3.3.1	Vent Well Installation 23
3.3.2	Monitoring Point Installations 23
3.4	Soil and Soil Gas Sampling 23
3.4.1	Soil Samples 23
3.4.2	Soil Gas Samples 26
3.5	Blower System 26
3.6	<i>In Situ</i> Respiration Test 28
3.7	Air Permeability Test 28
3.8	Installation of 1-Year Pilot Test Bioventing System 28
4.0	Handling of Investigation-Derived Waste 29
5.0	Exceptions to Protocol Procedures 29
6.0	Base Support Requirements 29
7.0	Project Schedule 30
8.0	Points of Contact 30
9.0	References 31

LIST OF FIGURES

No.	Title	Page
2.1	Site Locations with Respect to Base	3
2.2	Spill Layout, Spill Site No. 1	4
2.3	Site Layout, Building 457 Area	7
2.4	Site Layout, UST 702	10
3.1	Proposed Vent Well, Monitoring Point, and Blower Locations, Spill Site No 1	14
3.2	Proposal Injection Vent Well Construction Detail, Spill Site No 1	16
3.3	Proposed Monitoring Point Construction Detail, Spill Site No. 1	17
3.4	Proposed Vent Well, Monitoring Point, and Blower Locations, Building 457 Area	18
3.5	Proposed Injection Vent Well Construction Detail, Building 457 Area.....	20
3.6	Proposed Monitoring Point Construction Detail, Building 457 Area.....	21
3.7	Proposed Vent Well, Monitoring Point, and Blower Locations, UST 702.....	22
3.8	Proposed Injection Vent Well Construction Detail, UST 702	24
3.9	Proposed Monitoring Point Construction Detail, UST 702	25
3.10	Proposed Blower System Instrumentation Diagram for Air Injection	27

LIST OF TABLES

No.	Title	Page
2.1	Initial Soil Gas Chemistry, Spill Site No. 1	6
2.2	Initial Soil Gas Chemistry, Building 457 Area	9
2.3	Initial Soil Gas Chemistry, UST 702.....	12

DRAFT

BIOVENTING PILOT TEST WORK PLAN FOR SPILL SITE NO. 1, BUILDING 457 AREA, AND UST 702 EAKER AIR FORCE BASE BLYTHEVILLE, ARKANSAS

1.0 INTRODUCTION

This work plan presents the scope of a multiphase bioventing pilot test for *in situ* treatment of fuel-contaminated soils at Spill Site No. 1, Building 457 Area, and underground storage tank (UST) 702, at Eaker Air Force Base (AFB) (the Base), near the city of Blytheville, Arkansas. The pilot test will be performed by Parsons Engineering Science, Inc. (Parsons ES) [formerly Engineering-Science, Inc. (ES)]. The primary objectives of the proposed pilot tests are: 1) to assess the potential for supplying oxygen throughout the contaminated soil interval; 2) to determine the rate at which indigenous microorganisms will degrade fuel when supplied with oxygen-rich soil gas; 3) to evaluate the potential for sustaining these rates of biodegradation until fuel contamination is remediated to concentrations below regulatory standards; and 4) to determine design parameters, such as well spacing and flow rates, for full-scale bioventing system design.

The pilot tests will be conducted in three phases. The initial phase will consist of investigative drilling with a Geoprobe truck-mounted direct-push sampling rig, soil sampling, and vapor monitoring point (MP) installation at each site. Up to five vapor MPs will be installed with the Geoprobe rig at each site. The second phase will consist of construction of up to two air injection vent wells (VWs), and conducting an *in situ* respiration test and an air permeability test at each site. Existing groundwater monitoring wells may be used as VWs or additional vapor MPs if their screens extend above the saturated zone. Proposed VW and MP boring locations will be sampled and field screened for volatile organic compounds (VOCs) (using a photoionization detector [PID] and a total volatile hydrocarbon analyzer [TVHA]), prior to the final installation. This initial testing is expected to take approximately 3 weeks. During the last phase, the bioventing systems will be operated and monitored for a 1-year period. At the end of this period, soil gas sampling and respiration testing will be performed to determine the level of cleanup achieved after 1 year of treatment.

An initial pilot test results report will be prepared following completion of the initial phase of testing. This report will summarize the test results and make specific recommendations for continued system operation and/or expansion at each site. If the initial phase of testing proves bioventing to be an effective means of remediating soil

contamination, pilot test data will be used to prepare a conceptual full-scale system design and cost estimate, and to estimate the time required for site cleanup. At the end of the 1-year testing phase, a letter report will be prepared to summarize long-term testing results. Additional background information on the development and recent success of bioventing technology is presented in the protocol document entitled *Test Plan and Technical Protocol for a Field Treatability Test for Bioventing* (Hinchee *et al.*, 1992). This protocol document will serve as the primary reference for pilot test well designs and the detailed procedures to be used during the tests.

This work plan was developed following discussions among representatives from the Air Force Center for Environmental Excellence (AFCEE), Eaker Air Force Base Conversion Agency (AFBCA), and Parsons ES at a meeting held at the Base on November 16, 1995, the statement of work (SOW) for this project (US Air Force, 1994), and on a review of existing site characterization data. All the field work will follow the health and safety procedures presented in the program Health and Safety Plan for Extended Bioventing (Parsons ES, 1995), and the site-specific addendum to the program Health and Safety Plan. This work plan was prepared for AFCEE and AFBCA.

2.0 SITE DESCRIPTION

2.1 Spill Site No. 1

2.1.1 Site Location and History

Spill Site No. 1 is located near former Pumphouse No. 4 (Building 1020), between Pumphouse No. 2 (Building 1235) and the southeastern terminus of the flight apron. The site location relative to the Base is shown on Figure 2.1. Four 50,000-gallon underground storage tanks (USTs) containing jet propulsion fuel grade 4 (JP-4) were formerly located northeast and northwest of Pumphouse No. 4. The site layout is shown in Figure 2.2. Ten-inch and 6-inch pipelines were used to transfer fuel from the four tanks to the aircraft fueling hydrants on the flight apron. Pressure testing of the fuel hydrant system, performed in 1973, indicated the presence of a leak in the 6-inch fuel line, northwest of Pumphouse No. 4 (HNUS, 1994). During the subsequent pipeline repair, petroleum-contaminated soils were observed in the shallow excavation. The time-frame and amount of fuel released are unknown. The site is currently vacant and inactive.

2.1.2 Site Geology and Hydrology

Because bioventing technology is applied to unsaturated soils, this section will only discuss soils above the shallow aquifer. Subsurface soils at Spill Site No. 1 primarily consist of silty clay materials with interbedded sandy lenses to a depth of approximately 10.5 feet below ground surface (bgs). The proposed bioventing site is covered with grass. Groundwater was encountered at a depth of approximately 10 to 13 feet bgs during September 1995; however, seasonal fluctuations vary (HNUS, 1995a).

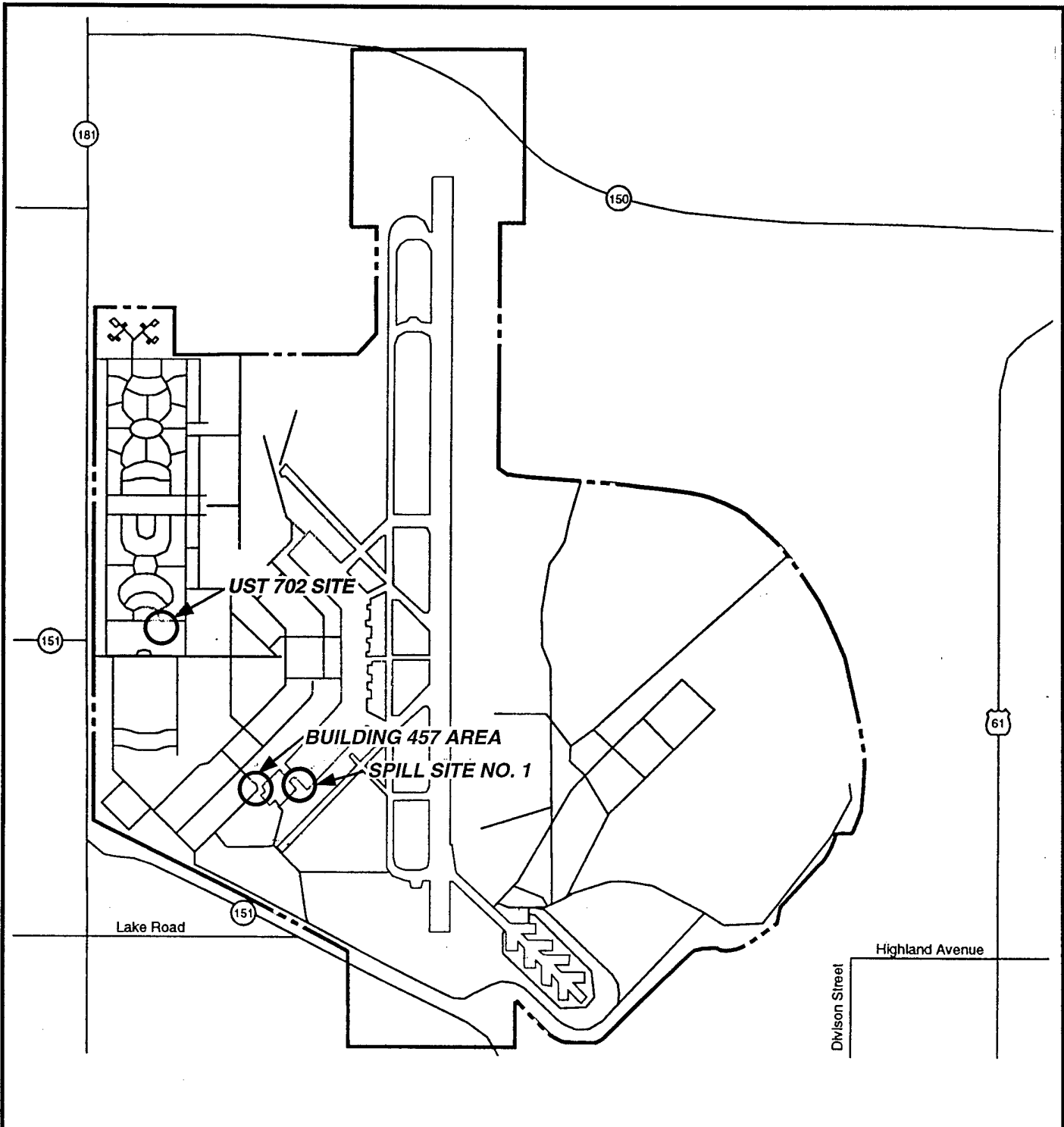

--- Base Boundary

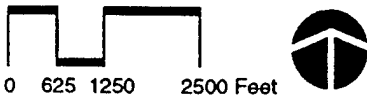

FIGURE 2.1

**SITE LOCATIONS WITH
RESPECT TO BASE**

Eaker AFB, Arkansas

**PARSONS
ENGINEERING SCIENCE, INC.**

Denver, Colorado

Source: US Air Force, 1995.

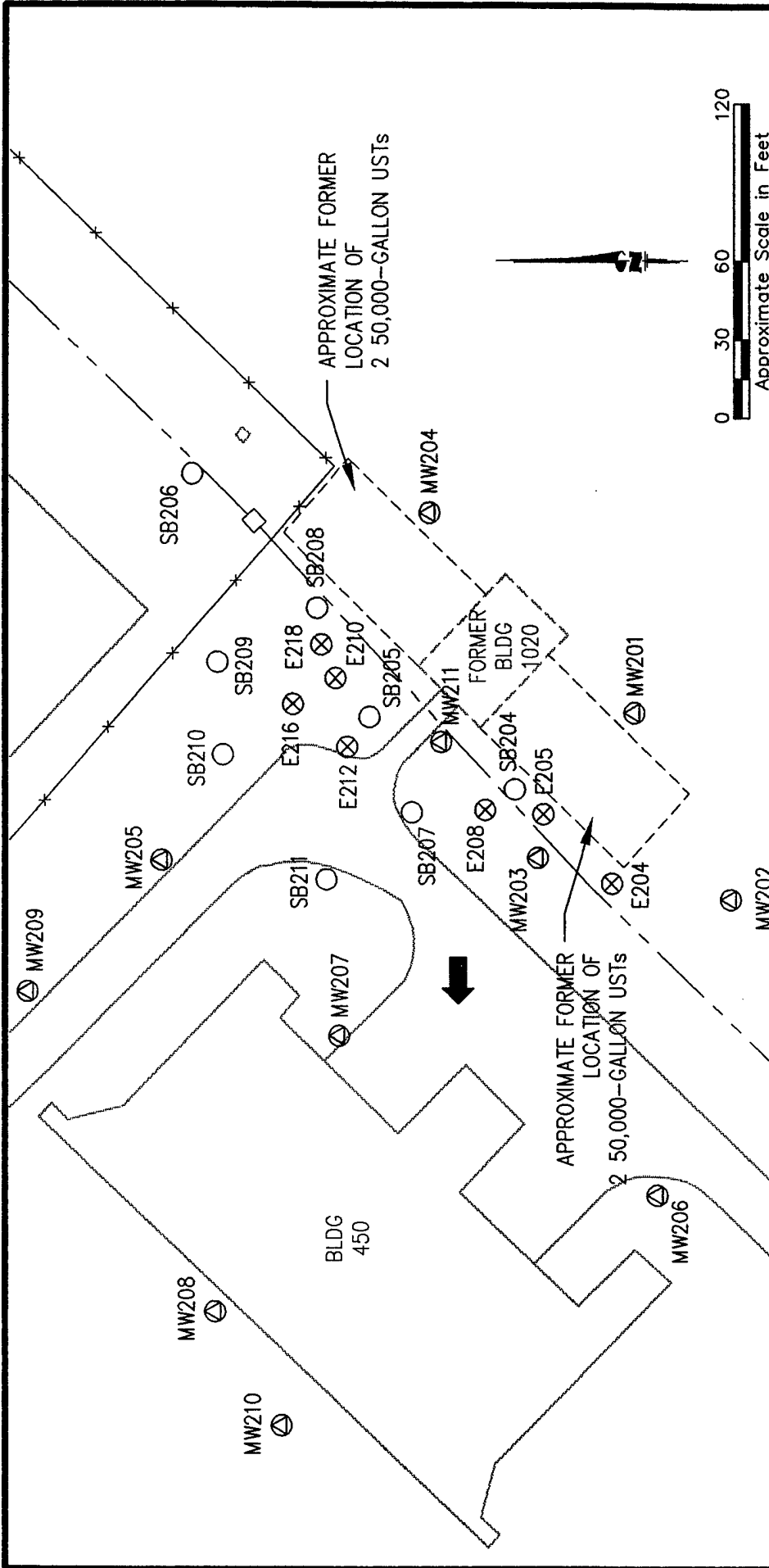

FIGURE 2.2

**SITE LAYOUT
SPILL SITE NO. 1**

Eaker AFB, Arkansas

**PARSONS
ENGINEERING SCIENCE, INC.**

Denver, Colorado

LEGEND

- ⊕ MONITORING WELLS
- PREVIOUS SOIL BORING
- ⊗ SOIL GAS SAMPLE LOCATION
- ➔ GROUNDWATER FLOW DIRECTION
- FUEL LINE

Source: HNUS, 1992.

2.1.3 Site Contaminants

The primary contaminants at this site are JP-4 petroleum hydrocarbons, which have been detected in the soils. The source of the fuel contamination was the leaking transfer pipeline. The highest concentrations of petroleum hydrocarbons in soils are found west, north, and northwest of Pumphouse No. 4 (Building 1020). The highest concentrations of organic compounds were found in "smear zone" soils near the water table in boreholes SB204, SB207, and SB208 (Figure 2.2). Total petroleum hydrocarbons (TPH) were detected at 9,500 milligrams per kilogram (mg/kg), and total benzene, toluene, ethylbenzene, and xylenes (BTEX) were detected at 295.2 mg/kg in soil boring SB208 at a depth of 9 feet bgs (HNUS, 1994). Soil boring SB204 contained 5,200 mg/kg of TPH and no BTEX at a depth of 6 to 7 feet bgs. Vadose zone soil contamination appears to be confined to the area between and adjacent to soil borings SB209 (north), and SB211 (west), monitoring well MW202 (south), and former Pumphouse No. 4 (Building 1020). The extent of contaminant migration in the smear zone along the water table may have been limited by site conditions (i.e., natural attenuation, low permeability aquifer), because TPH and BTEX compounds were not detected in significant concentrations downgradient from the site (wells MW205, MW206, and MW207) (HNUS, 1994).

Parsons ES conducted an initial soil gas survey of existing monitoring wells at Spill Site No. 1 in November 1995. Table 2.1 presents the results of the soil gas survey. Low oxygen concentrations measured at monitoring wells MW203 and MW207 indicate that without the benefit of air injection, natural biodegradation of JP-4 compounds may be limited. Additionally, monitoring well MW211 had a total volatile petroleum hydrocarbon (TVH) concentration of greater than 10,000 parts per million, volume per volume (ppmv). MW211 is screened partially across clean soils so high levels of oxygen in the soil gas is not surprising (Table 2.1). This survey confirmed that aerobic fuel biodegradation is occurring in contaminated soils, and that bioventing may be a feasible remediation technology at this site.

2.2 Building 457 Area

2.2.1 Site Location and History

Building 457 is located west of Spill Site No. 1 (Figure 2.1), and was formerly used as a fuel cell maintenance and repair shop (US Air Force, 1995). A 20,074-gallon steel UST used to store fuel oil, located at the northwest corner Building 457, was removed in August 1994 (US Air Force, 1995). The site layout is shown in Figure 2.3. Analytical results of soil samples taken from the sidewalls of the excavation pit indicated that all contaminated soil had not been removed (US Air Force, 1995). The excavated soil is being landfarmed on base. The excavation was backfilled with treated soil from the landfarm (Looney, 1996).

UST Area 410 is located approximately 200 feet southwest of Building 457, near the above-mentioned tank site. In the 1940s, 12 25,000-gallon USTs were installed and used for aviation fuel storage until the mid-1950s (Figure 2.3). Four of the tanks were removed in 1988, and the other eight were removed in November, 1995 (Looney,

TABLE 2.1
INITIAL SOIL GAS CHEMISTRY
SPILL SITE NO. 1
EAKER AFB, ARKANSAS

Sample Location	Screen Depth (feet bgs) ^{a/}	O ₂ (%)	CO ₂ (%)	Field TVH (ppmv) ^{b/}
MW201	7-22	9.1	8.0	1,000
MW202	6.6-21.6	8.5	4.3	4,800
MW203	6-21	4.2	11.2	>10,000
MW204	NA ^{c/}	19.8	1.6	150
MW207	11.6-21.6	0.0	12.0	6,000
MW211	9-19	18.9	2.3	>10,000

^{a/} bgs = below ground surface.

^{b/} Total volatile hydrocarbon field screening results reported in parts per million, volume per volume.

^{c/} NA= not available.

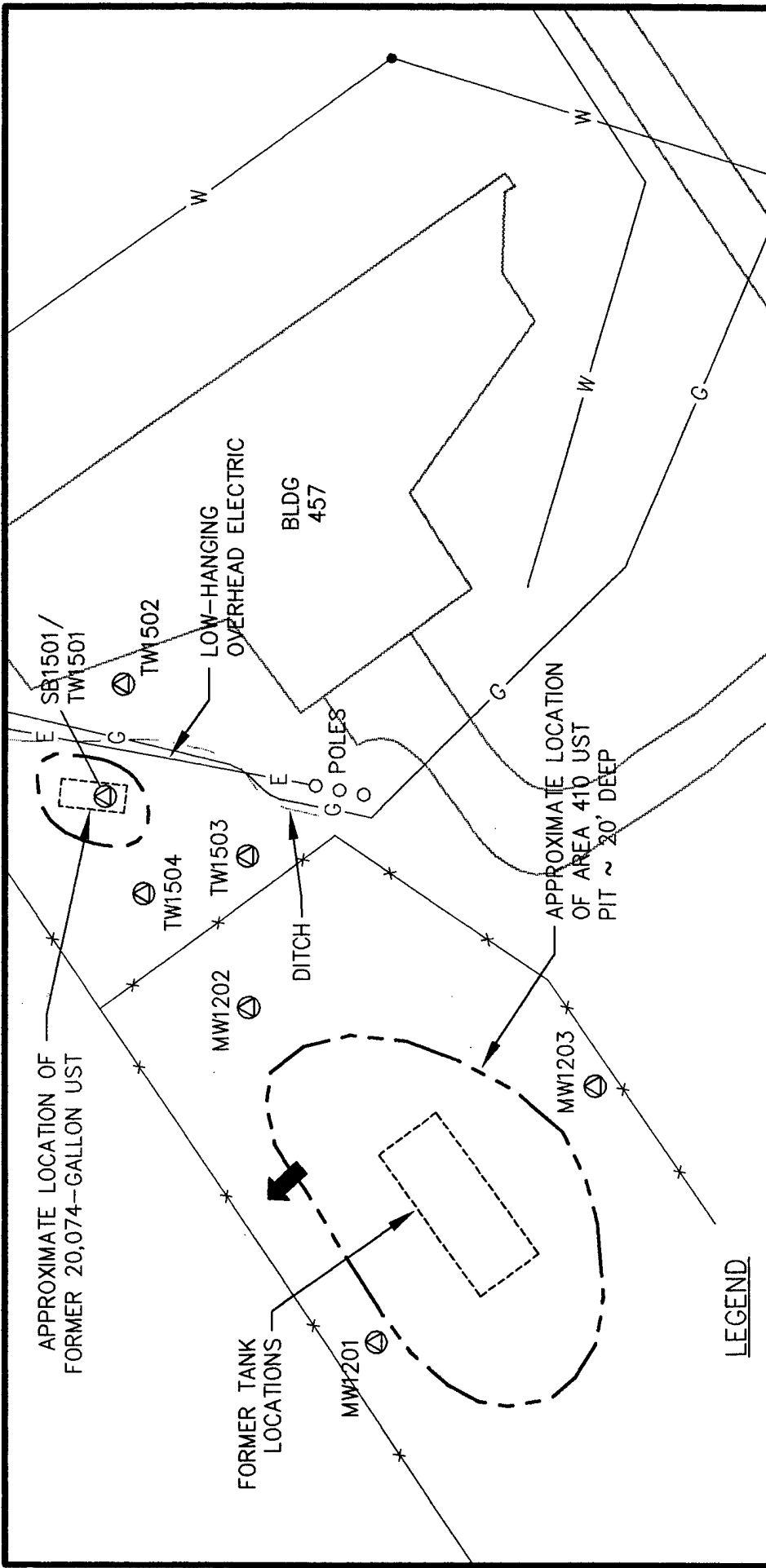

FIGURE 2.3

**SITE LAYOUT
BUILDING 457 AREA**

Eaker AFB, Arkansas

**PARSONS
ENGINEERING SCIENCE, INC.**

Denver, Colorado

LEGEND

- ⊕ EXISTING MONITORING WELL
- *— FENCE
- G— GAS UTILITY
- E— ELECTRIC UTILITY
- W— WATER LINE
- - - LIMITS OF EXCAVATION
- HYDRANT
- ➔ GROUNDWATER FLOW DIRECTION (DURING RI STEP 1 PROJECT)

Source: HNU5, 1995b.

1996). Approximately 4,500 cubic yards of contaminated soil was excavated and is being treated at a Base soil landfarm; however, some smear zone contamination above state soil cleanup levels for TPH is anticipated. The excavation pit was backfilled with treated soil from the landfarm (Looney, 1996).

2.2.2 Site Geology and Hydrology

Subsurface soils at the Building 457 Area are similar to those at Spill Site No. 1; primarily consisting of silty clay materials with interbedded sandy lenses to a depth of 12 feet bgs. Groundwater is encountered at a depth of approximately 3.5 to 9.5 feet bgs, and flows to the northwest or southwest, depending on seasonal variations (HNUS, 1995a).

2.2.3 Site Contaminants

The primary contaminants near Building 457 are petroleum hydrocarbons, which have been detected in the soils and groundwater. The sources of vadose zone contamination near Building 457 and Area 410 were UST leaks at the respective areas. The highest concentrations of organics at the Building 457 UST site were found in samples collected at the south and east excavation walls. TPH were detected at concentrations of 1,400 mg/kg and 4,700 mg/kg at a depth of 12 feet bgs at the east and south locations, respectively. TPH analytical results from samples from the north and west excavation walls were non-detects (US Air Force, 1995). Based on soil headspace readings and analytical results from the monitoring wells, it appears that vadose zone soil contamination is confined to the area immediately adjacent to the tank excavation.

Parsons ES conducted an initial soil gas survey of existing monitoring wells at the Building 457 tank site. Table 2.2 presents the results of the soil gas survey. Low oxygen concentrations measured at monitoring wells TW1501 and TW1503 (Figure 2.3) indicate that without the benefit of air injection, natural biodegradation of fuel compounds may be limited. The majority of petroleum hydrocarbon contamination at the site appears to be in the smear zone.

Most of the contaminated soils at the 410 Area have been excavated. A soil gas survey conducted in 1995 for HNUS indicates that soils upgradient from the excavation are relatively clean; however, because the survey did not encompass the downgradient (northwest) side, site conditions are not fully characterized. During bioventing activities at the Building 457 UST site, a soil gas survey will be conducted at monitoring wells MW1201, MW1202, and MW1203 at the 410 Area (Figure 2.3) to determine if oxygen levels are sufficient to sustain microbial activity. Should 410 Area site conditions require bioventing, the pilot test system at Building 457 UST site may be expanded to include the 410 Area.

TABLE 2.2
INITIAL SOIL GAS CHEMISTRY
BUILDING 457 AREA
EAKER AFB, ARKANSAS

Sample Location	Screen Depth (feet bgs) ^{a/}	O ₂ (%)	CO ₂ (%)	Field TVH (ppmv) ^{b/}
TW1501	6-16	3.0	10.3	70
TW1502	8-18	9.5	7.3	94
TW1503	5.5-15.5	2.0	7.1	960
TW1504	5.5-15.5	7.9	5.9	140

^{a/} bgs = below ground surface.

^{b/} Total volatile hydrocarbon field screening results reported in parts per million, volume per volume.

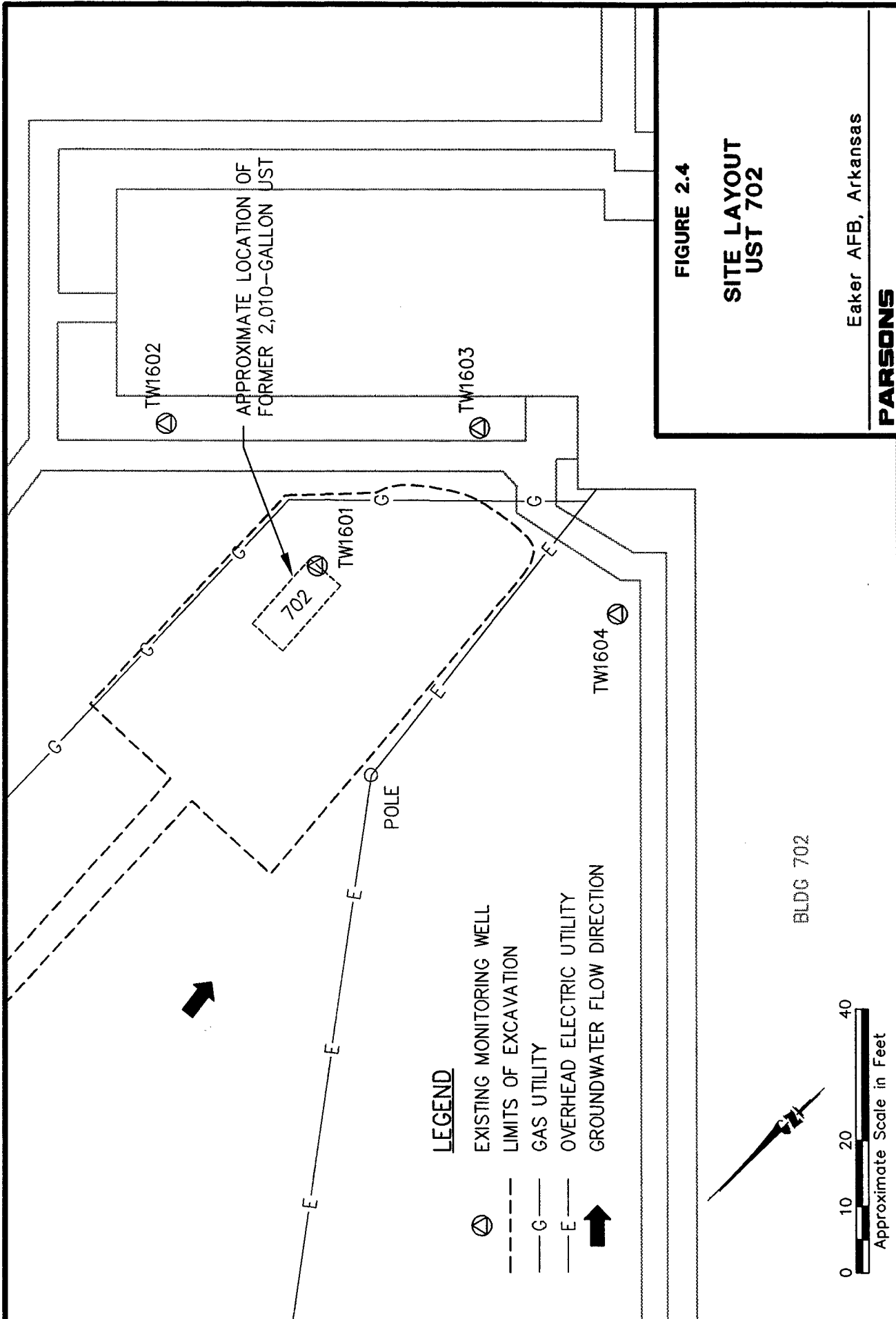

LEGEND

- ⊕ EXISTING MONITORING WELL
- - - - - LIMITS OF EXCAVATION
- G - - - GAS UTILITY
- E - - - OVERHEAD ELECTRIC UTILITY
- ➔ GROUNDWATER FLOW DIRECTION



BLDG 702

FIGURE 2.4
SITE LAYOUT
UST 702

Eaker AFB, Arkansas

PARSONS
ENGINEERING SCIENCE, INC.

Denver, Colorado

Source: Ogden Environmental and Energy Services, 1994.

K:\AFCEE\726876\68760001, 01/31/96 at 11:23

2.3 UST 702

2.3.1 Site Location and History

Former UST 702 was located adjacent to Building 702 in the west central portion of the Base (Figure 2.1). The site layout is shown in Figure 2.4. The former 2,010-gallon tank, used to store fuel oil that was used for heating Building 702, was removed in June 1994. Although the tank was over excavated, tank removal soil sampling results confirmed that not all contaminated soil had been removed from the site (US Air Force, 1995). The excavation has since been backfilled with treated soil from the onsite landfarm (Looney, 1996). The site is currently vacant and inactive.

2.3.2 Site Geology and Hydrology

Subsurface soils near former UST 702 primarily consist of silt and sand from ground surface to 12 feet bgs, and silty clay materials at a depth of 12 to 16 feet bgs. Groundwater was encountered at a depth of approximately 8 to 9 feet bgs during September 1995 (HNUS, 1995b).

2.3.3 Site Contaminants

The primary contaminants at this site are petroleum hydrocarbons, which have been detected in the soils. Soil samples collected during the tank removal activities indicate that the highest concentrations of petroleum hydrocarbons in soils were detected at the southern edge of the tank excavation. TPH were detected at the south wall (12,000 mg/kg), east wall (6,100 mg/kg), and west wall (3,100 mg/kg) at a depth of 17 feet bgs (US Air Force, 1995). The majority of petroleum hydrocarbon contamination at the site appears to be in the smear zone. Soil sample analytical results from samples collected during the monitoring well installation, indicate that the extent of contamination is limited to the area adjacent to the former tank excavation (HNUS, 1995b). No BTEX samples have been collected to date.

Parsons ES conducted an initial soil gas survey of existing monitoring wells at the UST 702 site. Table 2.3 presents the results of the soil gas survey. Low oxygen concentrations measured at monitoring well TW1601 (Figure 2.4) indicate that without the benefit of air injection, natural biodegradation of fuel hydrocarbons may be limited.

3.0 PILOT TEST ACTIVITIES

The purpose of this section is to describe the pilot test activities proposed for Spill Site No. 1, Building 457 Area, and UST 702. The proposed locations and construction details for the VWs and vapor MPs are discussed. Where appropriate, an existing monitoring well may be used as a VW. Existing monitoring wells that are installed in clean soils will be used as background MPs. Soil and soil gas sampling procedures and the blower configuration that will be used to inject air (oxygen) into contaminated soils also are discussed in this section. Finally, a brief description of the pilot test procedures is provided.

TABLE 2.3
INITIAL SOIL GAS CHEMISTRY
UST 702
EAKER AFB, ARKANSAS

Sample Location	Screen Depth (feet bgs) ^{a/}	O ₂ (%)	CO ₂ (%)	Field TVH (ppmv) ^{b/}
TW1601	6-16	1.1	11.0	88
TW1602	6-16	20.7	0.4	40
TW1603	6-16	20.8	0.05	0
TW1604	6-16	20.8	0.05	3

^{a/} bgs = below ground surface.

^{b/} Total volatile hydrocarbon field screening results reported in parts per million, volume per volume.

The bioventing technology is intended to remediate contamination only in the unsaturated zone. Therefore, pilot test activities will be confined mainly to unsaturated soils. Prior to installation of the VWs and vapor MPs at each site, the anticipated VW and MP borehole locations will be presampled with a Geoprobe® truck-mounted hydraulic direct-push rig. The locations will be sampled continuously from approximately 3 feet bgs to 1 foot below the groundwater surface and screened for VOCs with a PID and a THVA. Before abandoning the Geoprobe® boreholes, the site engineer will identify the boreholes to be used as vapor MPs. Typically, multiple-depth vapor MPs are preferred; however, considering the shallow groundwater table at Eaker AFB, only single-depth vapor MPs may be installed in most cases. The MPs will be installed in select Geoprobe® boreholes, within the most contaminated unsaturated interval as indicated by field screening for VOCs. If subsequent soil gas sampling of the newly installed MPs at Building 457 Area and UST 702 reveals sufficient oxygen concentrations (>15%) in native soils adjacent to the excavation, then a VW will be installed in the center of the tank excavation. If significant vadose zone petroleum contamination is encountered in native soils adjacent to the excavation, conceptually, a vent well(s) will be installed approximately 10 to 15 feet from the excavation. Additionally, selected existing monitoring wells that are not used as VWs will be used as vapor MPs. No dewatering will take place during the pilot tests.

3.1 Test Design for Spill Site No. 1

A general description of criteria for siting VWs and vapor MPs is included in the protocol document (Hinchee *et al.*, 1992). Figure 3.1 illustrates the proposed locations of the three VWs (including two existing monitoring wells to be used as VWs) and five MPs at Spill Site No.1. Review of the construction details of the existing groundwater monitoring wells (Appendix A) indicated that monitoring wells MW203 and MW211 are suitable for use as VWs or as vapor MPs. Conceptually, it is anticipated that air will be injected into monitoring wells MW203 and MW211, and the one proposed additional VW. The final location of the additional VW may vary slightly from the proposed location shown on Figure 3.1 if significant fuel contamination is not observed in the Geoprobe® borehole. Soils in this area are TPH-contaminated and oxygen-depleted (< 2 percent), and biological activity should, therefore, be stimulated by oxygen-rich soil gas ventilation during pilot test operations.

Because of the low-permeability soils in fuel-contaminated regions, fine-grained soils near the surface (which reduce airflow to the surface), and Parsons ES's experience with similar soil types, the potential radius of venting influence around the VWs is expected to be 30 feet. Five vapor MPs (MPA, MPB, MPC, MPD, and MPE) will be located within a 30-foot radius of the VWs (Figure 3.1).

3.1.1 Vent Well Installation

The additional VW will be constructed of 4-inch-diameter Schedule 40 polyvinyl chloride (PVC) casing, with an estimated 10-foot interval of 0.04-inch slotted screen set at 5 to 15 feet bgs. Flush-threaded PVC casing and screen with no organic solvents or glues will be used. The filter pack will be clean, well-rounded silica sand with a 6-9 grain size, which will be placed in the annular space to 1 foot above the screened

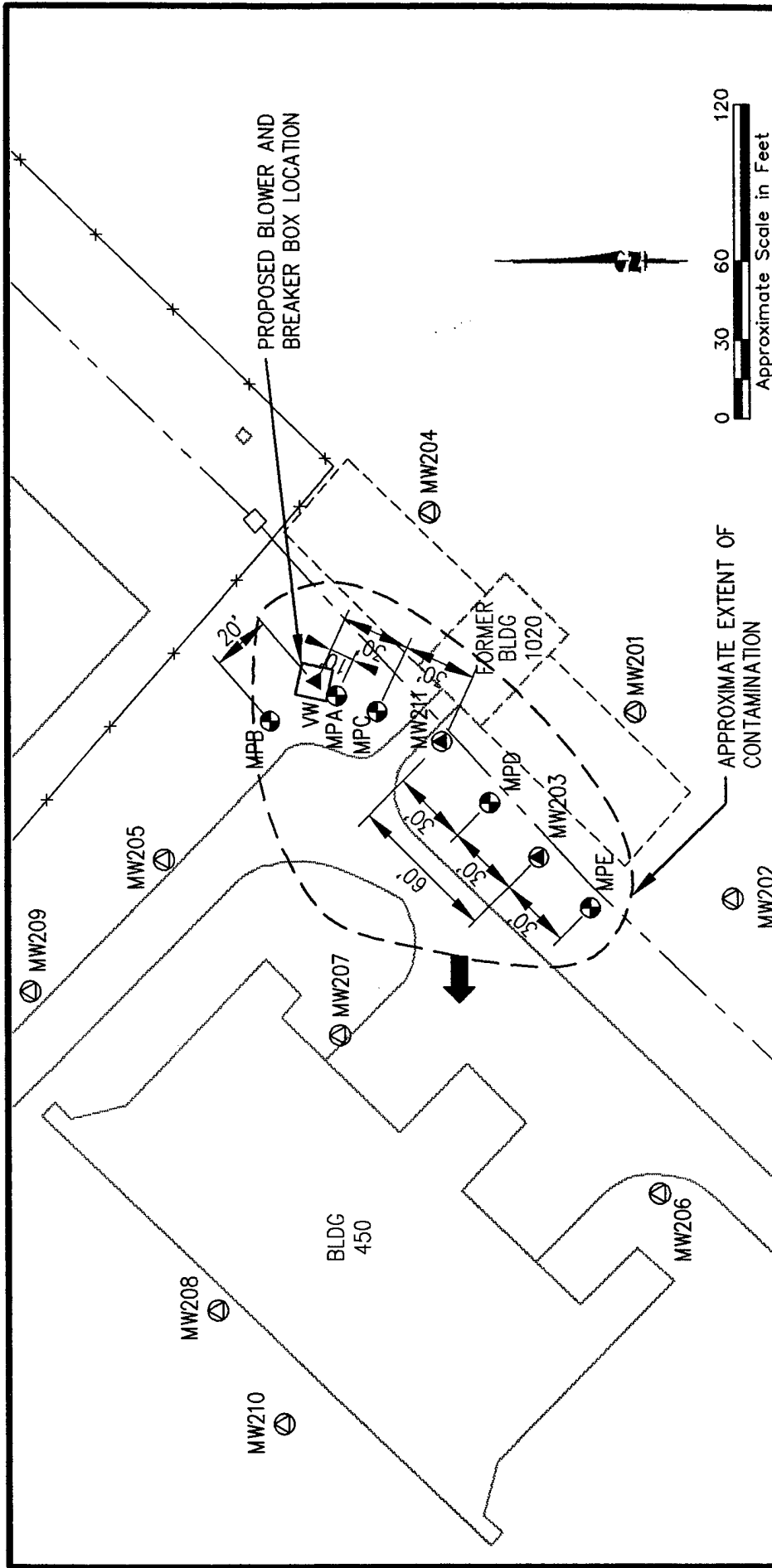

FIGURE 3.1

**PROPOSED VENT WELL,
MONITORING POINT, AND
BLOWER LOCATIONS
SPILL SITE NO. 1**

Eaker AFB, Arkansas

**PARSONS
ENGINEERING SCIENCE, INC.**

Denver, Colorado

LEGEND

- ▲ PROPOSED VENT WELL (VW)
- MONITORING WELL/PROPOSED VW
- ⊙ PROPOSED MONITORING POINT
- ⊙ MONITORING WELLS
- ➔ GROUNDWATER FLOW DIRECTION
- FUEL LINE

Source: HNUS, 1992.

interval. A 2.5-foot-thick bentonite seal will be placed directly over the filter pack to produce an air-tight seal above the screened interval. The bentonite seal, consisting of granular bentonite, will be placed in 6-inch layers, with each layer hydrated in place with potable water prior to the addition of subsequent layers. A complete seal is critical to prevent injected air from short-circuiting to the surface during the bioventing test. The VW annulus will be filled with a cement/bentonite slurry to the ground surface. The blower will be placed directly over the VW, so a protective well box will not be necessary. Figure 3.2 illustrates the proposed additional VW construction detail for this site.

3.1.2 Monitoring Point Installations

A typical multi-depth vapor MP installation for this site is shown in Figure 3.3. Soil gas oxygen, carbon dioxide, and total volatile hydrocarbon (TVH) concentrations will be monitored at depths of approximately 6 feet and/or 9 feet bgs at each location. Soil temperature will be monitored using a thermocouple installed at the deep screened interval of MPA. Multi-depth monitoring will confirm that the entire soil profile is receiving oxygen, and fuel biodegradation rates can be measured at the two depths. If contamination is limited to the smear zone, only one MP interval will be installed at each location in the contaminated interval.

Each MP will be constructed with one or two vapor probes placed within a 6-9 silica sand pack, separated by bentonite seals. Each vapor probe, constructed of 6-inch-long, 0.25-inch, outside-diameter (OD) stainless steel screen implant attached to 0.5-inch-OD, high density polyethylene (HDPE) tubing that extends to the ground surface. The top of each 0.5-inch HDPE riser will be completed with a 3/8-inch needle valve. The screens will be placed within a 1-foot layer of 6-9 silica sand. The annular space between the screened MP intervals and the ground surface will be sealed with bentonite to isolate the monitoring interval. The bentonite seals will consist of granular bentonite hydrated in place. The bentonite will be placed in 6-inch layers and hydrated with potable water prior to placement of subsequent layers to ensure complete saturation of the bentonite. Additional details on VW and MP construction are presented in Section 4 of the protocol document.

3.2 Test Design for Building 457 Area

The former UST area immediately west of Building 457 is the proposed bioventing pilot test area (Figure 2.2); however, if significant vadose zone contamination (to a depth of approximately 9.5 feet bgs) is discovered in 410 Area during Geoprobe[®] investigative drilling and soil gas sampling, an additional VW and MPs may be installed, and the Building 457 Area blower system may be expanded to treat the 410 Area. Figure 3.4 illustrates the proposed VW location to be drilled at Building 457 Area, and proposed Geoprobe[®] locations to be screened for siting prospective locations for MPs or additional VWs. Review of the construction details of the existing groundwater monitoring wells (Appendix A) indicates that monitoring wells MW1201 and MW1202 are suitable for use as VWs, or as additional vapor MPs. The final location of the proposed VW to be installed near Building 457 may vary slightly from

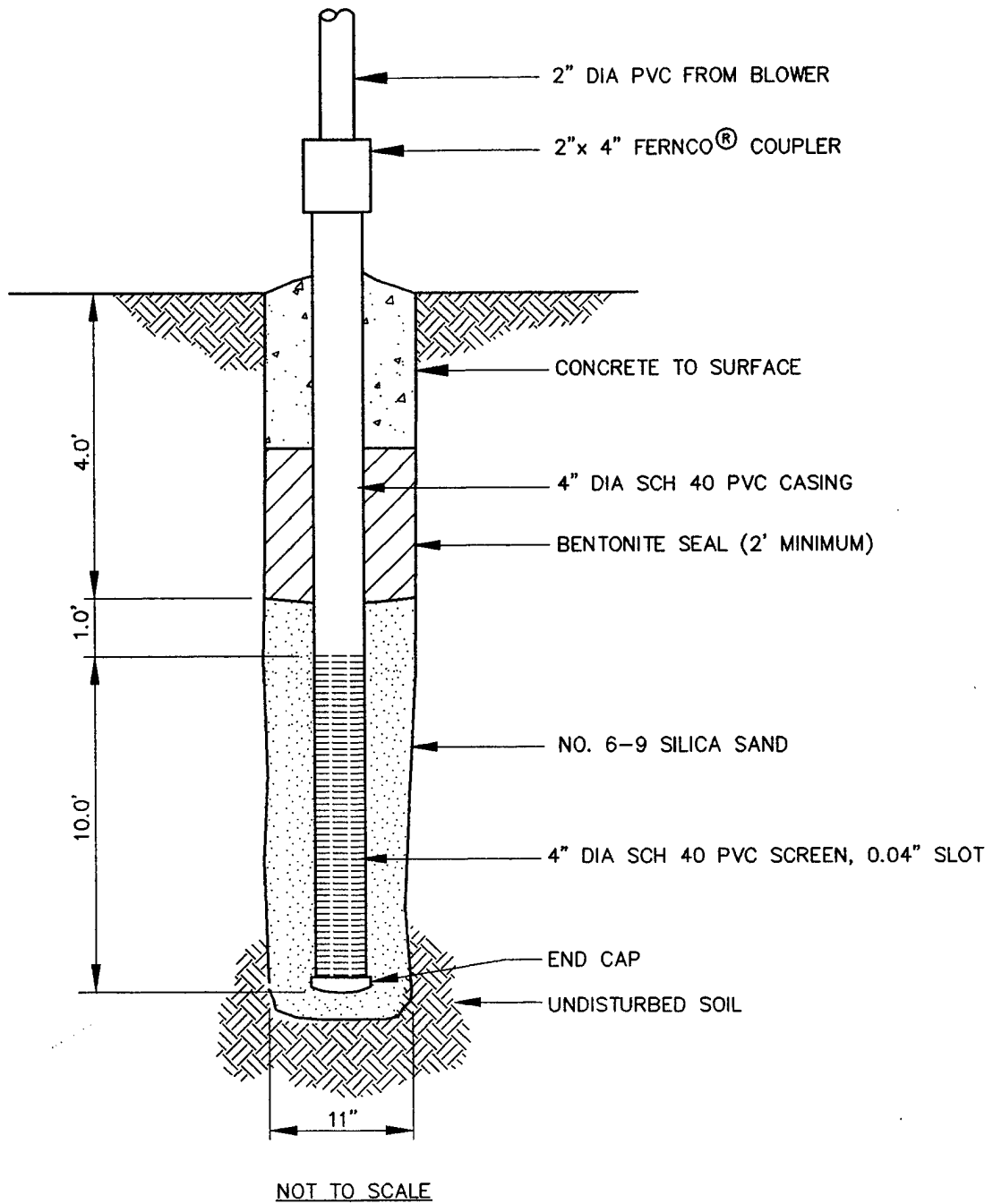

FIGURE 3.2
PROPOSED INJECTION VENT
WELL CONSTRUCTION DETAIL
SPILL SITE NO. 1

Eaker AFB, Arkansas

PARSONS
ENGINEERING SCIENCE, INC.

Denver, Colorado

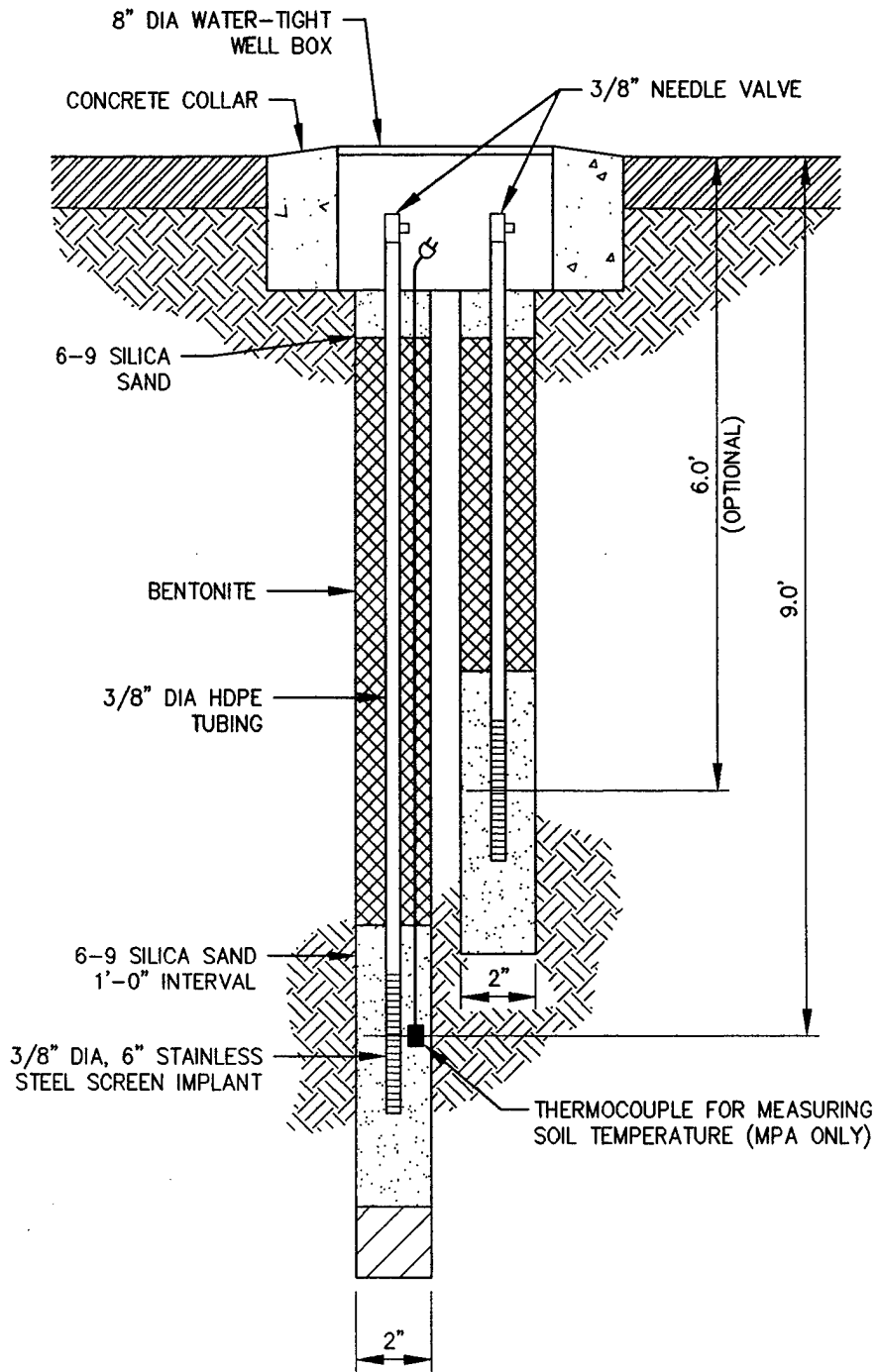

FIGURE 3.3
PROPOSED MONITORING POINT
CONSTRUCTION DETAIL
SPILL SITE NO. 1
(TYPICAL)

Eaker AFB, Arkansas

PARSONS
ENGINEERING SCIENCE, INC.

Denver, Colorado

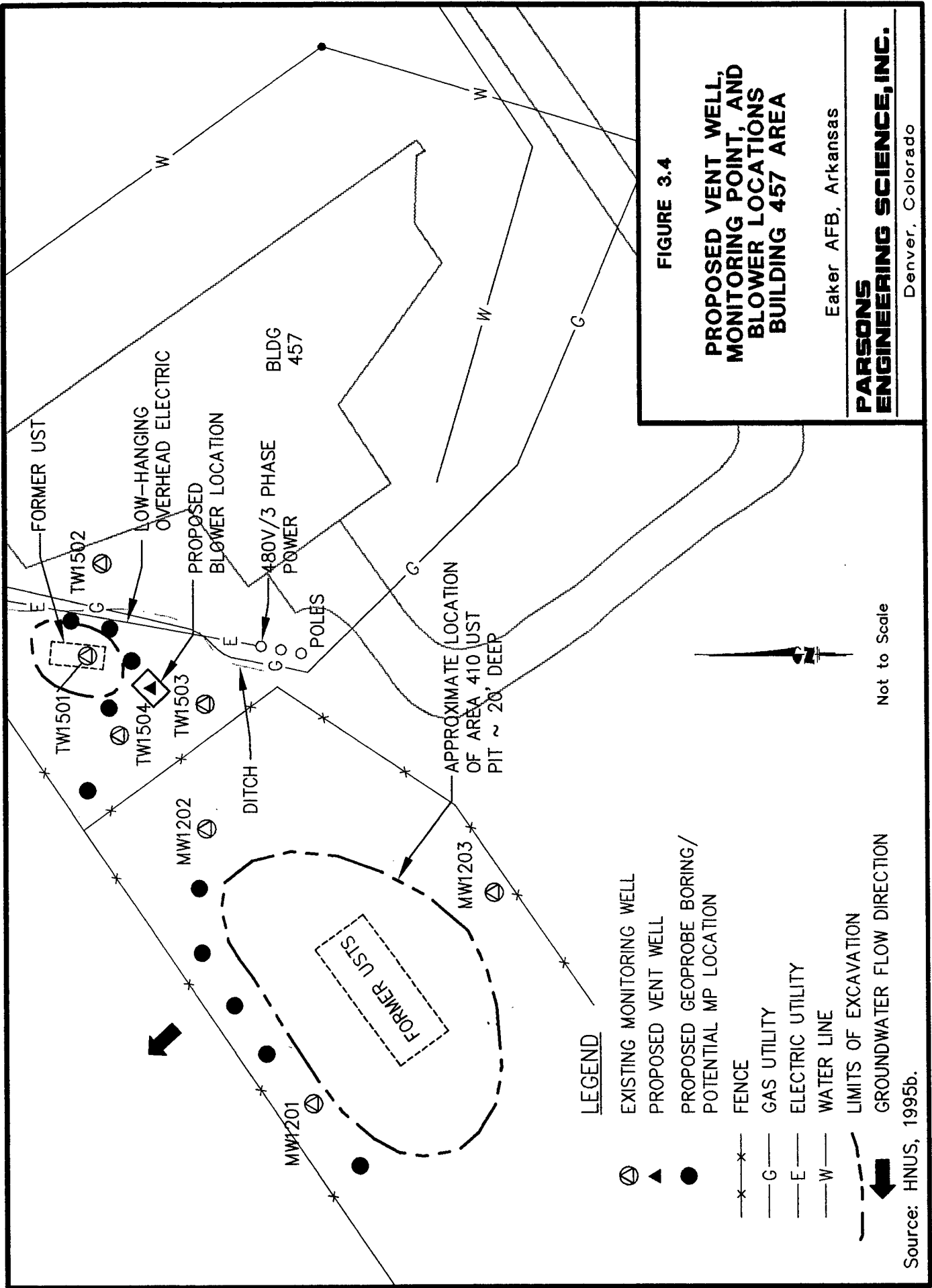

FIGURE 3.4

**PROPOSED VENT WELL,
MONITORING POINT, AND
BLOWER LOCATIONS
BUILDING 457 AREA**

Eaker AFB, Arkansas

**PARSONS
ENGINEERING SCIENCE, INC.**

Denver, Colorado

LEGEND

- ⊕ EXISTING MONITORING WELL
- ▲ PROPOSED VENT WELL
- PROPOSED GEOPROBE BORING/
POTENTIAL MP LOCATION
- *— FENCE
- G— GAS UTILITY
- E— ELECTRIC UTILITY
- W— WATER LINE
- - - LIMITS OF EXCAVATION
- ➔ GROUNDWATER FLOW DIRECTION

Not to Scale

Source: HNUS, 1995b.

the proposed location shown on Figure 3.4 if significant fuel contamination is not observed in the Geoprobe® borehole. If contamination is observed to extend no more than approximately 7 feet outside the former excavation, then the VW will be installed in the center of the excavation.

Because of the low-permeability soils in fuel-contaminated regions, fine-grained soils near the surface (which reduce airflow to the surface), and Parsons ES's experience with similar soil types, the potential radius of venting influence around the VW is expected to be 30 feet. Conceptually, up to two VWs and five MPs may be installed at Building 457 Area; at least two MPs will be located within a 30-foot radius of the proposed VW (Figure 3.4).

3.2.1 Vent Well Installation

The additional VW(s) will be constructed of 4-inch-diameter Schedule 40 PVC with an estimated 10-foot interval of 0.04-inch slotted screen set at 4 to 14 feet bgs. Flush-threaded PVC casing and screen with no organic solvents or glues will be used. The filter pack will be clean, well-rounded silica sand with a 6-9 grain size which will be placed in the annular space to 1 foot above the screened interval. A 3-foot-thick bentonite seal will be placed directly over the filter pack to produce an air-tight seal above the screened interval. The bentonite seal, consisting of granular bentonite, will be placed in 6-inch layers, with each layer hydrated in place with potable water prior to the addition of subsequent layers. A complete seal is critical to prevent injected air from short-circuiting to the surface during the bioventing test. A cement/bentonite slurry will be placed above the seal to the ground surface. The blower shed will be placed over the VW, so a protective well box will not be necessary. Figure 3.5 illustrates the proposed VW construction detail for this site.

3.2.2 Monitoring Point Installations

A typical multi-depth vapor MP installation for this site is shown in Figure 3.6. It is anticipated that soil gas oxygen, carbon dioxide, and TVH concentrations will be monitored only at a single depth interval of approximately 7.5 feet bgs at each location. Soil temperature will be monitored using a thermocouple installed at one of the MPs. Geoprobe® soil samples, collected in clear polybutyrate liners, will be visually inspected and screened for VOCs. A vapor probe will be placed only in those soil intervals with apparent petroleum contamination, where oxygen levels are expected to be depleted. Each MP will be constructed as described in Section 3.1.2.

3.3 Test Design for UST 702

Figure 3.7 illustrates the proposed VWs and MPs to be installed at UST 702. Review of the construction details of the existing groundwater monitoring wells (Appendix A) indicated that monitoring wells TW1601, TW1602, and TW1603 are suitable for use as VWs, or as additional vapor MPs. The final locations of the two additional proposed VWs and MPs may vary slightly from the proposed locations shown on Figure 3.7 if significant fuel contamination is not observed in the predrilled Geoprobe® borings. Soils in this area are TPH-contaminated and expected to be

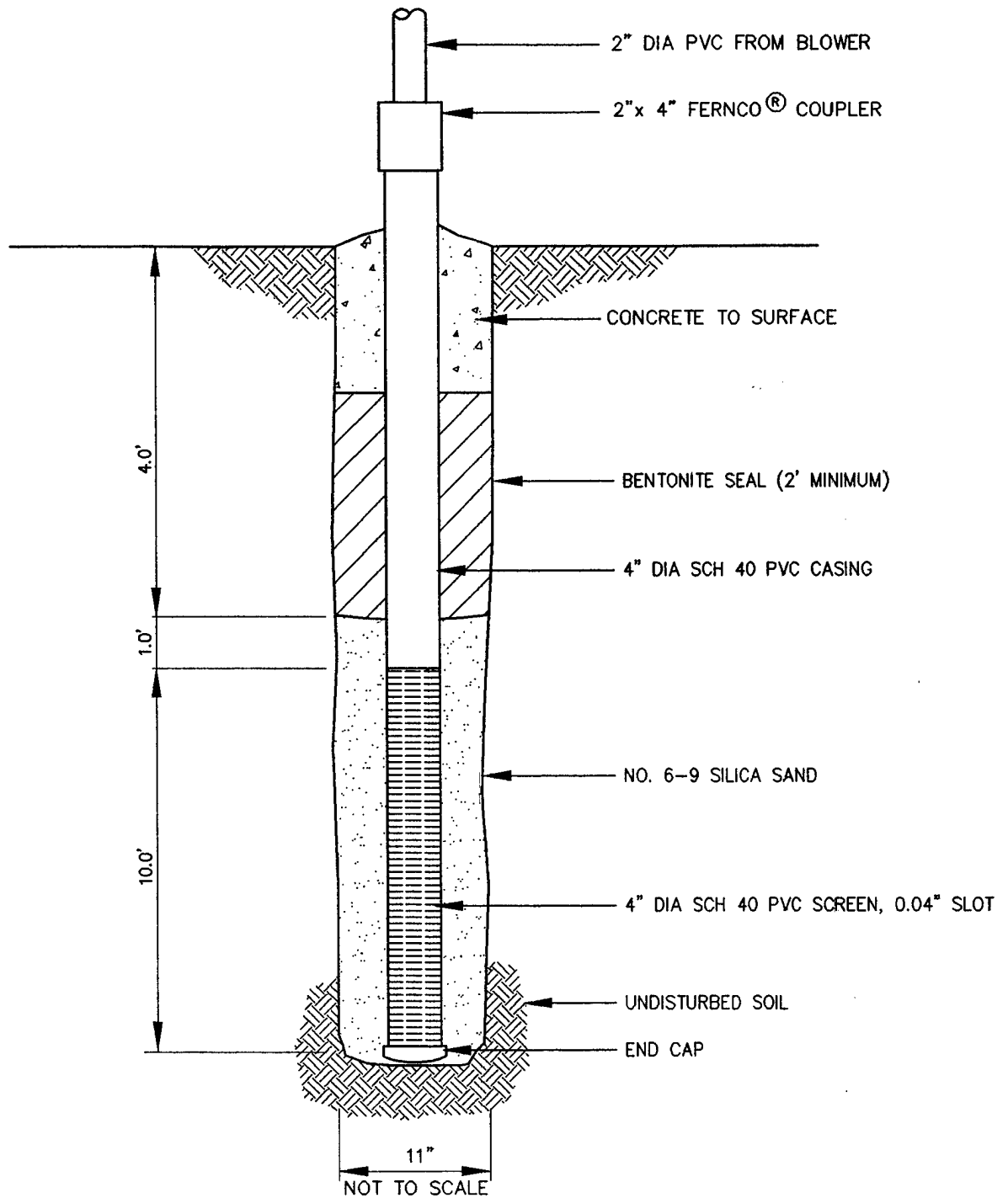

FIGURE 3.5

**PROPOSED INJECTION VENT
WELL CONSTRUCTION DETAIL
BUILDING 457 AREA**

Eaker AFB, Arkansas

**PARSONS
ENGINEERING SCIENCE, INC.**

Denver, Colorado

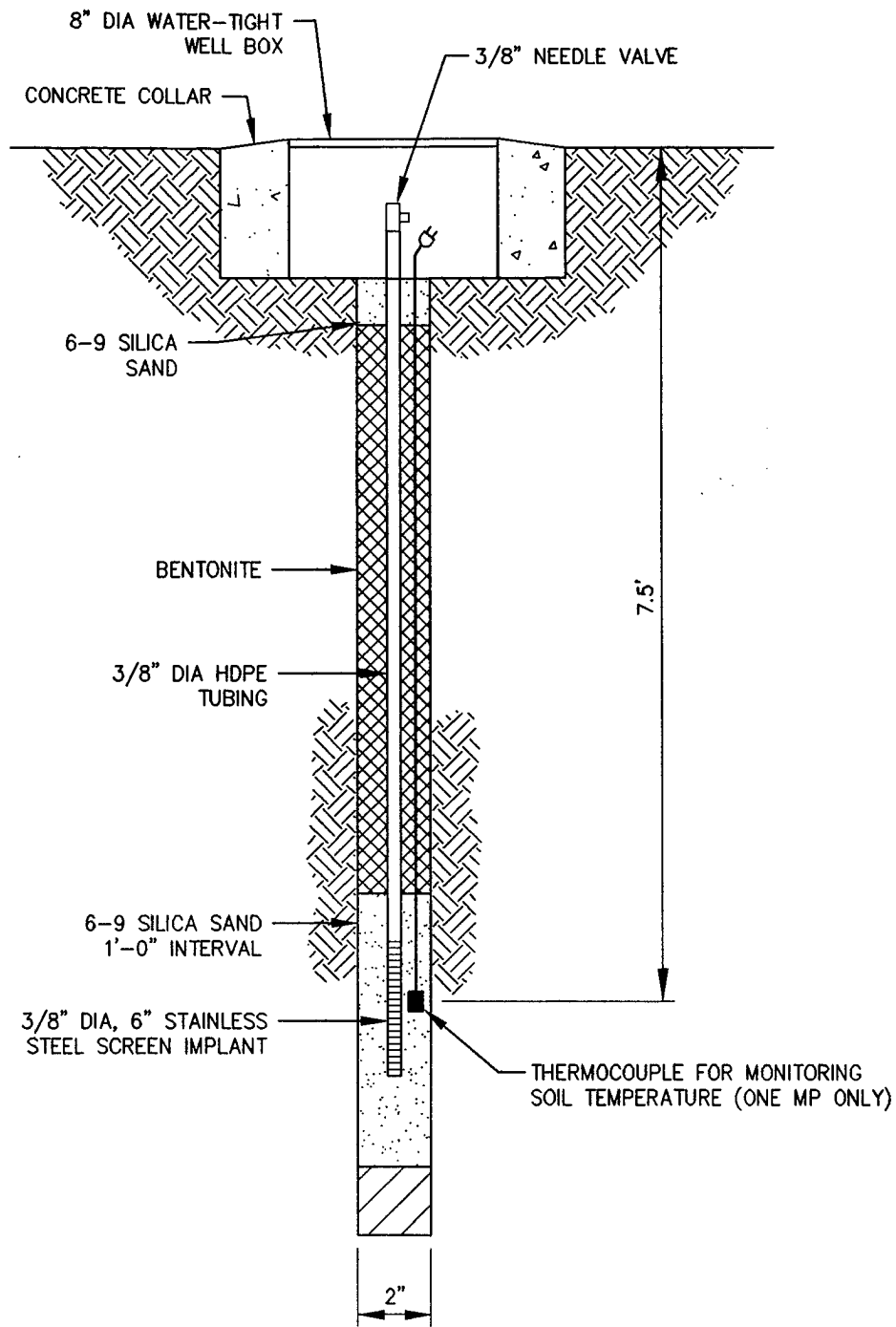

FIGURE 3.6

PROPOSED MONITORING POINT CONSTRUCTION DETAIL BUILDING 457 AREA (TYPICAL)

Eaker AFB, Arkansas

PARSONS ENGINEERING SCIENCE, INC.

Denver, Colorado

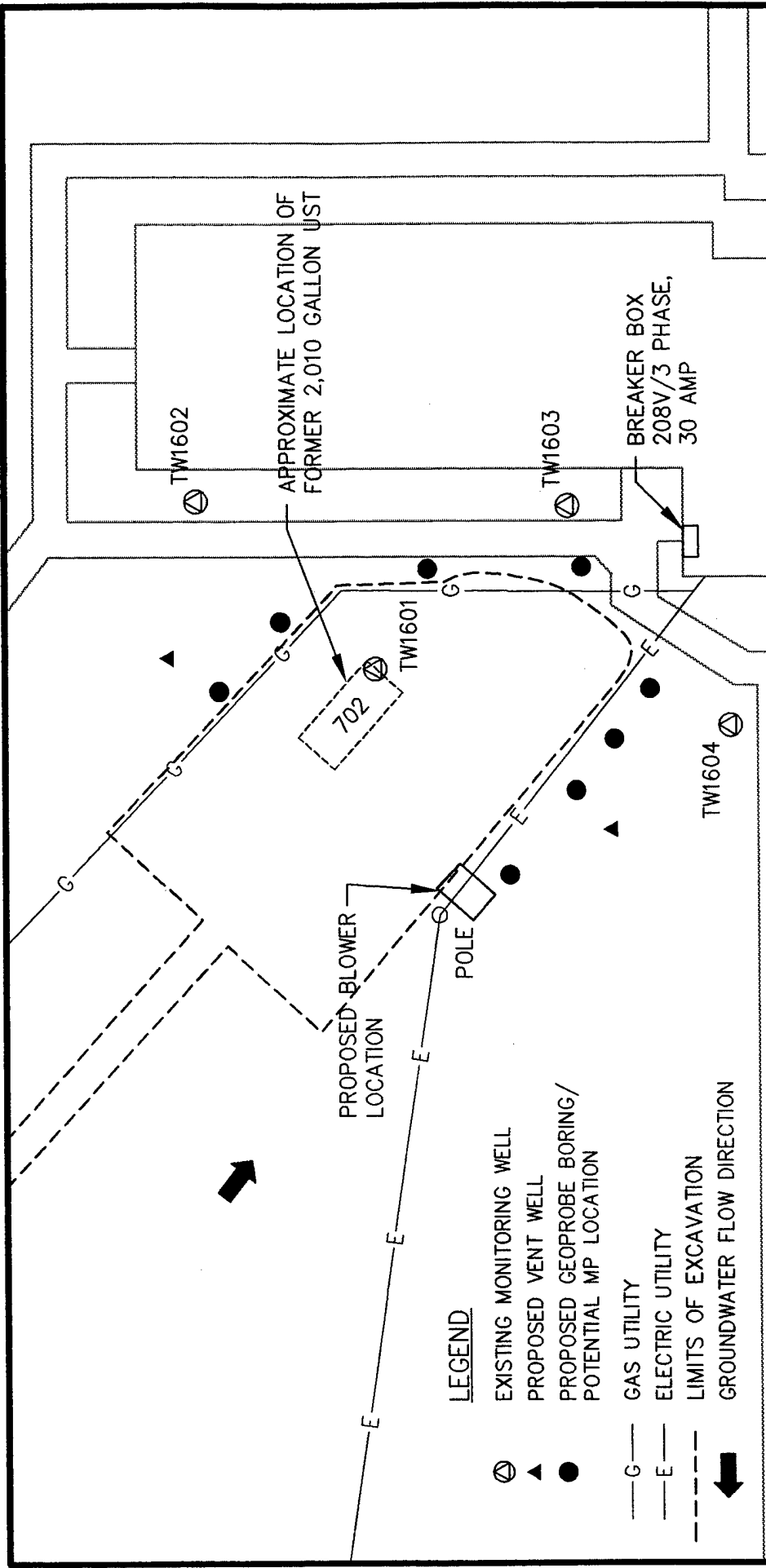

FIGURE 3.7

**PROPOSED VENT WELL,
MONITORING POINT AND
BLOWER LOCATIONS
UST 702**

Eaker AFB, Arkansas

**PARSONS
ENGINEERING SCIENCE, INC.**

Denver, Colorado

Source: Ogden Environmental and Energy Services, 1994.

K:\AFCEE\726876\68760006, 02/08/96 at 15:32

oxygen-depleted (< 2%), and biological activity should therefore be stimulated by oxygen-rich soil gas ventilation during pilot test operations.

Because of the low-permeability soils in fuel-contaminated regions, fine-grained soils near the surface (which reduce airflow to the surface), and Parsons ES's experience with similar soil types, the potential radius of venting influence around the VWs is expected to be 30 feet. Four MPs will be located within a 30-foot radius of the VWs (Figure 3.7).

3.3.1 Vent Well Installation

The additional VW(s) will be constructed of 4-inch-diameter Schedule 40 PVC with an estimated 10-foot interval of 0.04-inch slotted screen set at 5 to 15 feet bgs. Flush-threaded PVC casing and screen with no organic solvents or glues will be used. The filter pack will be clean, well-rounded silica sand with a 6-9 grain size which will be placed in the annular space to 1 foot above the screened interval. A 2.5-foot-thick bentonite seal will be placed directly over the filter pack to produce an air-tight seal above the screened interval. The bentonite seal, consisting of granular bentonite, will be placed in 6-inch layers, with each layer hydrated in place with potable water prior to the addition of subsequent layers. A complete seal is critical to prevent injected air from short-circuiting to the surface during the bioventing test. The VW surface completion will consist of 12-inch diameter, flush-mounted, protective well box emplaced in a concrete pad. Figure 3.8 illustrates the proposed VW construction detail for this site.

3.3.2 Monitoring Point Installations

A typical multi-depth vapor MP installation for this site is shown in Figure 3.9. It is anticipated that soil gas oxygen, carbon dioxide, and TVH concentrations will be monitored only at a single depth interval of approximately 8 feet bgs at each MP location. Soil temperature will be monitored using thermocouples installed at one of the MPs. Geoprobe[®] soil samples, collected in clear polybutyrate liners, will be visually inspected and screened for VOCs. A vapor probe will be placed only in those intervals with apparent petroleum contamination, where oxygen levels are expected to be depleted. Each MP will be constructed as described in Section 3.1.2.

3.4 Soil and Soil Gas Sampling

3.4.1 Soil Samples

Six soil samples will be collected from each pilot test area during installation of VWs and MPs and submitted to an analytical laboratory for analysis. Sampling procedures will follow those outlined in the protocol document. A THVA will be used during drilling to screen split-spoon samples for intervals of significant fuel contamination. Based on field screening results, six samples from the most highly contaminated locations at each site will be analyzed for total extractable petroleum hydrocarbons (TEPH) or total volatile petroleum hydrocarbons (TVPH) by EPA Method 8015 and BTEX by EPA Method 8020. Three of these samples from each site

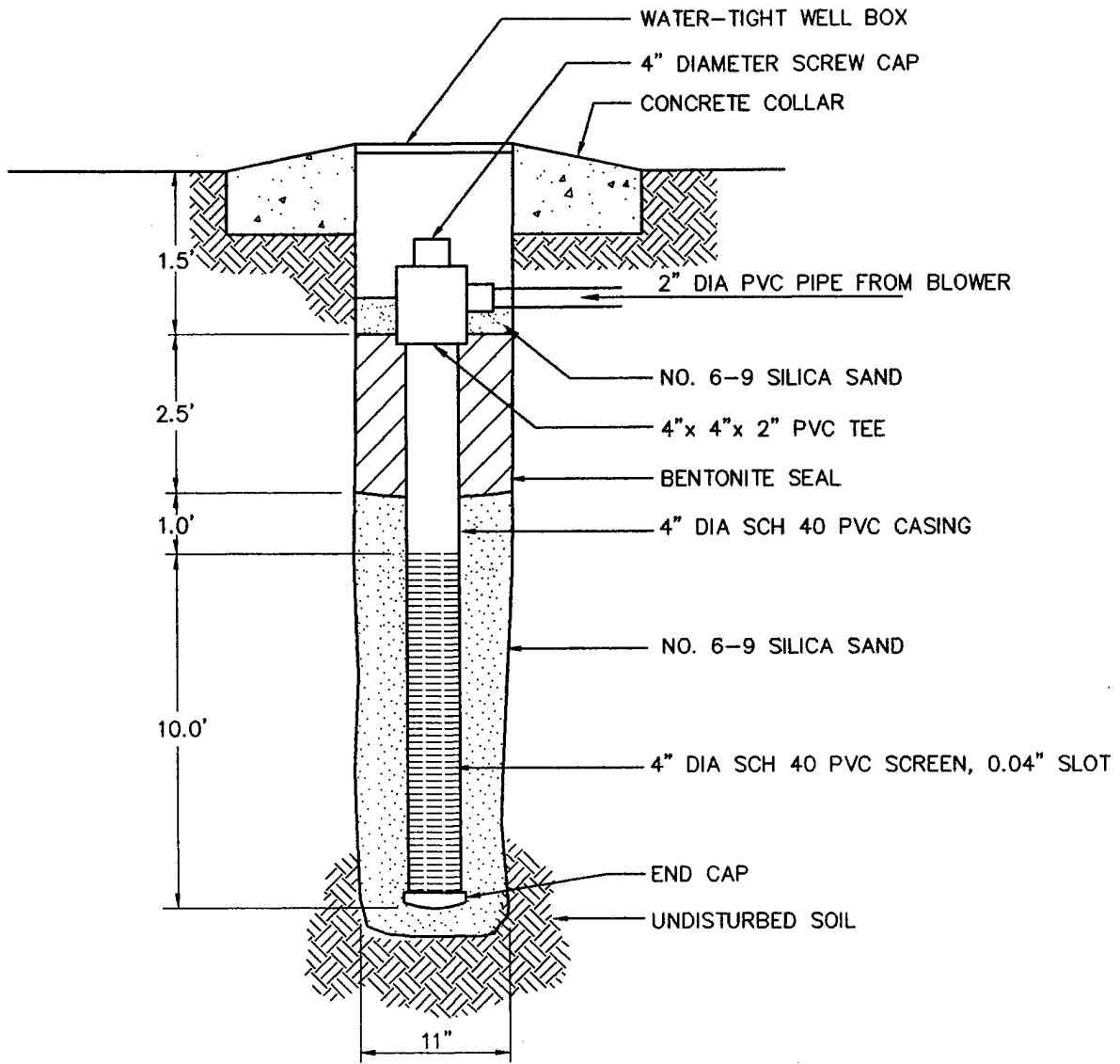

NOT TO SCALE

FIGURE 3.8
PROPOSED INJECTION VENT
WELL CONSTRUCTION DETAIL
UST 702
(TYPICAL)

Eaker AFB, Arkansas

PARSONS
ENGINEERING SCIENCE, INC.

Denver, Colorado

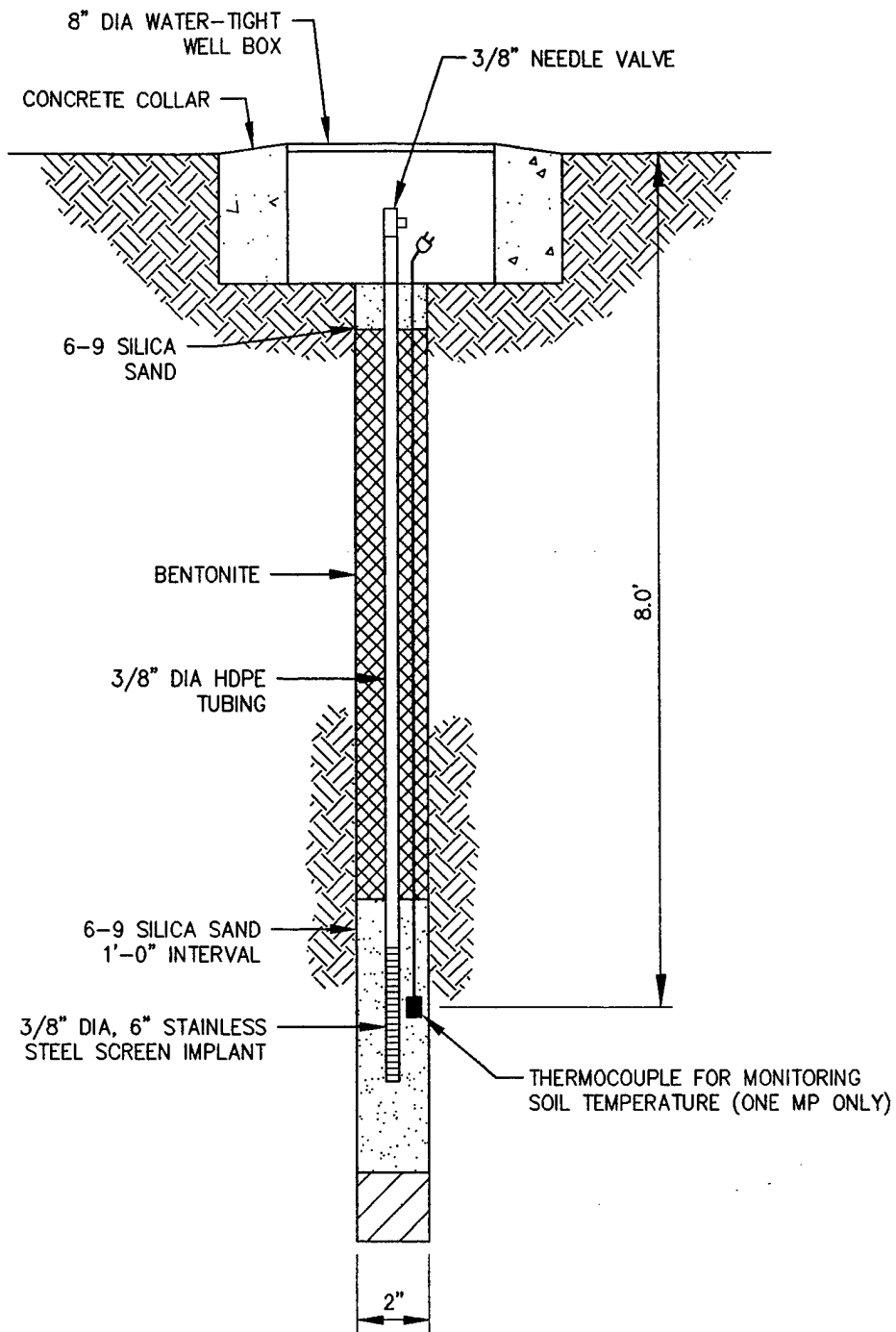

FIGURE 3.9
PROPOSED MONITORING POINT
CONSTRUCTION DETAIL
UST 702
(TYPICAL)

Eaker AFB, Arkansas

PARSONS
ENGINEERING SCIENCE, INC.

Denver, Colorado

also will be analyzed for soil moisture, pH, particle size, alkalinity, total iron, and nutrients. One background sample, collected from a Geoprobe[®] boring drilled adjacent to the selected background monitoring well, will be analyzed for total Kjeldahl nitrogen (TKN).

Samples for TEPH, TVPH, and BTEX analysis will be collected from Geoprobe[®] boreholes. Soil samples collected in the polybutyrate liners for TPH, BTEX, and physical parameter analyses will be immediately trimmed, and the ends will be sealed with aluminum foil or Teflon[®] fabric held in place by plastic caps. Soil samples will be labeled following the nomenclature specified in the protocol document (Section 5), wrapped in plastic, placed in a cooler with ice, and maintained at a temperature of approximately 4 degrees centigrade (°C) for shipment. A chain-of-custody form will be completed, and the cooler will be shipped to an AFCEE-approved laboratory for analysis.

3.4.2 Soil Gas Samples

At each site, soil gas samples will be collected from nearby monitoring wells, VWs, and MPs, and field screened for oxygen, carbon dioxide, and TVH. Soil gas samples from six of the most contaminated locations at each site will be collected in SUMMA[®] canisters in accordance with the Bioventing Field Sampling Plan (ES, 1992) and submitted for laboratory analysis. These soil gas samples will be used to predict potential air emissions, to determine the reduction in BTEX and TVH during the 1-year test, and to detect any migration of these vapors from the source area.

Soil gas sample canisters will be placed in a small cooler and packed with foam pellets to prevent excessive movement during shipment. Samples will be sent at ambient temperature to prevent condensation of hydrocarbons. A chain-of-custody form will be completed, and the cooler will be shipped to the Air Toxics, Inc. laboratory in Folsom, California for analysis.

3.5 Blower System

A 3-horsepower positive displacement blower capable of injecting air over a wide range of flow rates and pressures will be used to conduct the initial air permeability tests at each site. Figure 3.10 presents a schematic of a typical air injection system used for pilot testing. The maximum power requirement anticipated for these pilot tests is 230-volt, three-phase, 30-amp service. Electrical power will be obtained from a nearby power pole located adjacent to each proposed blower location. An electrical distribution panel, shut-off switch, and electrical outlets will be installed on the existing pole or on the blower shed. Installation of electrical equipment and necessary wiring will be provided by an electrical subcontractor hired by Parsons ES.

LEGEND

- ① INLET AIR FILTER
- ② VACUUM GAUGE (IN H₂O)
- ③ BLOWER
- ④ AUTOMATIC PRESSURE RELIEF VALVE
- ⑤ MANUAL PRESSURE RELIEF (BLEED) VALVE
- ⑥ PRESSURE GAUGE - (IN H₂O)
- ⑦ TEMPERATURE GAUGE - (°F)
- ⑧ BREAKER BOX

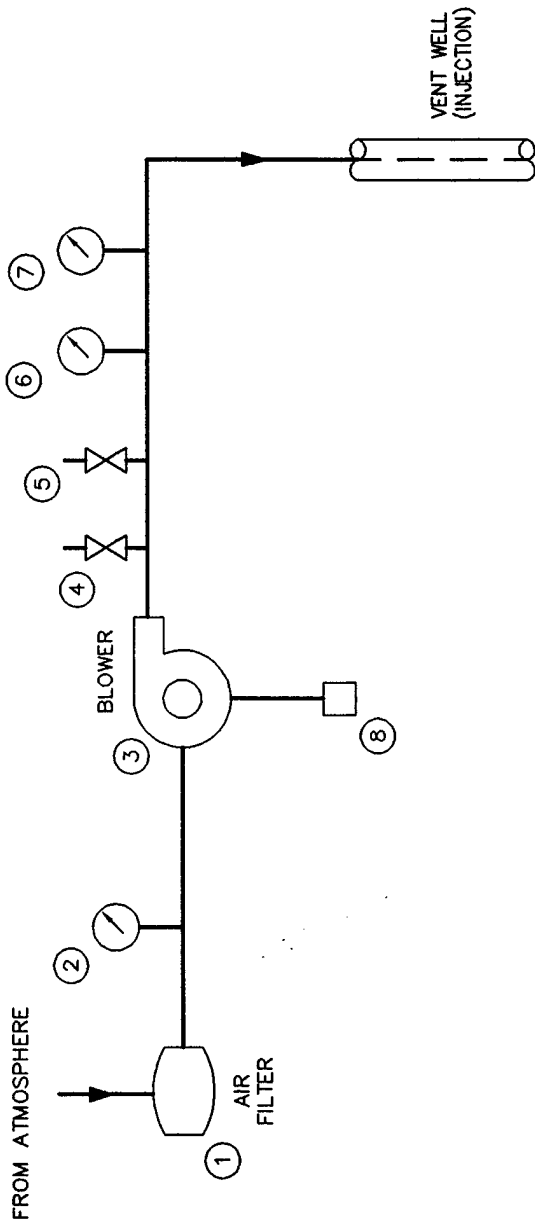

NO SCALE

FIGURE 3.10

**PROPOSED BLOWER SYSTEM
INSTRUMENTATION
DIAGRAM FOR AIR INJECTION
(TYPICAL)**

Eaker AFB, Arkansas

**PARSONS
ENGINEERING SCIENCE, INC.**

Denver, Colorado

3.6 *In Situ* Respiration Test

The objective of the *in situ* respiration test is to determine the rate at which soil bacteria degrade petroleum hydrocarbons. Respiration tests will be performed at selected MPs where bacterial biodegradation of hydrocarbons is indicated by low oxygen levels and elevated carbon dioxide concentrations in the soil gas. Using 1-cubic-foot-per-minute (cfm) pumps, air will be injected into approximately four MP depth intervals containing low levels (< 2 %) of oxygen at each site. Monitoring wells with low oxygen levels may also be tested. A 20-hour air injection period will be used to oxygenate local contaminated soils. At the end of the 20-hour air injection period, the air supply will be cut off, and oxygen, carbon dioxide, and TVH concentrations will be monitored during the following 48 to 72 hours. The decline in oxygen and increase in carbon dioxide concentrations over time will be used to estimate rates of bacterial degradation of fuel residuals. Helium will also be injected into the selected MP screened intervals to determine the effectiveness of the bentonite seals. Additional details on *in situ* respiration testing are found in Section 5.7 of the protocol document (Hinchee *et al.*, 1992).

3.7 Air Permeability Test

The objective of the air permeability testing is to determine the extent of the subsurface that can be oxygenated using one air injection VW. Prior to initiating the test, baseline concentrations of oxygen, carbon dioxide, and TVH will be measured in soil gas from the VW and each MP screened interval.

Air will be injected into one of the newly installed VWs at each site using a positive displacement blower unit, and pressure response will be measured at each existing monitoring well within 50 feet of the injection well and each newly installed MP with differential pressure gauges to determine the region influenced by the unit. Oxygen will also be monitored in the MPs to ascertain whether oxygen levels in the soil increase as the result of air injection. One air permeability test lasting 4 to 24 hours will be performed at each site.

Discrete vapor MPs provide a better indicator as to pressure response in different soil profiles, so testing information gathered from the monitoring wells will be used primarily to determine the radius of oxygen influence. At least two MPs (at varying distances) will be installed prior to permeability testing. Initial soil gas sampling will be performed prior to air injection.

3.8 Installation of 1-Year Pilot Test Bioventing System

Extended, 1-year pilot-scale bioventing systems will also be installed at Spill Site No. 1, Building 457 Area, and UST 702. The systems will be designed based upon the results of the initial respiration and permeability tests. However, it is anticipated that the extended test blowers will have flow rates in the range of 25 to 50 scfm and will not exceed 4 horsepower. The blowers will each be housed in a small, lockable,

prefabricated shed to provide protection from the weather. At each site, a licensed electrical subcontractor to Parsons ES will provide a 208-volt, three-phase, 30-amp service. The blower units will be explosion-proof, and electrical wiring will be installed in accordance with the National Electric Code (NEC) and Base codes for locations with potentially explosive atmospheres.

The systems will be in operation for 1 year. Bimonthly system checks will be performed by Eaker AFB personnel. If required, major maintenance of the blower units will be performed by Parsons ES personnel. Detailed blower system information and a maintenance schedule will be included in the operation and maintenance (O&M) manual that will be provided to the AFBCA. After the systems have operated for 1 year, Parsons ES personnel will return to the sites to conduct *in situ* respiration testing and soil gas sampling to determine the long-term effectiveness of the systems.

4.0 HANDLING OF INVESTIGATION-DERIVED WASTE

All soil cuttings will be hauled to a nearby Base soil landfarm designated by the Base. Few cuttings will be generated from the VW boreholes; only about 4 cubic yards. Drill cuttings will be disposed of in accordance with the current procedures for ongoing remedial investigations at Eaker AFB.

5.0 EXCEPTIONS TO PROTOCOL PROCEDURES

The procedures that will be used to measure the air permeability of the soil and *in situ* respiration rates are described in Sections 4 and 5, respectively, of the protocol document. No exceptions to the protocol are anticipated.

6.0 BASE SUPPORT REQUIREMENTS

The following Base support is needed prior to the arrival of the drilling subcontractor and the Parsons ES pilot test team:

- Assistance in obtaining drilling and digging permits.

During initial testing, the following Base support is needed:

- Twelve square feet of desk space and a telephone in a building located as close to the site as practical.
- The use of a facsimile machine for transmitting 15 to 20 pages of test results.
- A decontamination area where the driller can clean augers between borings.
- A potable water supply for well construction and decontamination activities.

During the 1-year extended pilot test, Base or AFBCA personnel will be required to perform the following activities:

- Check the blower system once per every two weeks to ensure that it is operating, and to record the air injection pressure and other parameters. Parsons ES personnel will provide a brief training session on this procedure.
- If the blower stops working, notify Mr. Dave Teets or Mr. John Ratz of Parsons ES at (303) 831-8100; or Lt Maryann Jenner of AFCEE at (210) 536-5688, or Mr. Jerry Hansen of AFCEE at (210) 536-4353.

7.0 PROJECT SCHEDULE

The following schedule is contingent upon approval of this pilot test work plan and completion of base support requirements.

<u>Event</u>	<u>Date</u>
Draft Test Work Plan to AFCEE/Eaker AFB	9 February 1996
Field Mobilization	16 March 1996
Preconstruction Meeting	18 March 1996 (10AM)
Begin Initial Pilot Tests	18 March 1996
Postconstruction Meeting	4 April 1996 (10AM)
Demobilization	5 April 1996
Letter Results Report	17 May 1996
Final Respiration Test and Soil Gas Sampling	March 1997

8.0 POINTS OF CONTACT

Mr. Thomas Zachary
AFBCA/OL-J
P.O. Box 9400
Gosnell, AR 72319-0400
COM (501) 532-6550
FAX (501) 532-8738

Mr. David Teets and Mr. John Ratz
Parsons Engineering Science, Inc.
1700 Broadway, Suite 900
Denver, CO 80290
(303) 831-8100
Fax (303) 831-8208

Lt Maryann Jenner or Jerry Hansen
AFCEE/ERT
8001 Arnold Drive
Brooks AFB, TX 78235-5000
(210) 536-5688, (210) 536-4353
Fax (210) 536-4330

9.0 REFERENCES

- Engineering-Science, Inc. 1992. *Field Sampling Plan for AFCEE Bioventing*. January.
- Haliburton NUS Environmental Corporation (HNUS), 1992. Technical Memorandum (Step 2) for the Remedial Investigation/Feasibility Study.
- HNUS, 1994. *Description of Current Conditions*. Prepared for Air Force Base Conversion Agency (AFBCA), Eaker AFB, Arkansas. June
- HNUS, 1995a. Unpublished site data, Eaker AFB, Arkansas.
- HNUS, 1995b. Information received via fax on December 8.
- Hinchee, R.E., S.K. Ong, R.N. Miller, D.C. Downey, and R. Frendt. 1992. *Test Plan and Technical Protocol for a Field Treatability Test for Bioventing*. May.
- Looney, Randal J. 1996. Personal communication. Phone conversation between Randal J. Looney (Eaker AFBCA) and David B. Teets (Parsons ES) regarding site history of 410 Area, February 1, 1996.
- Ogden Environmental and Energy Systems, 1994. Tank removal report drawing.
- Parsons Engineering Science, Inc. 1995. *Program Health and Safety Plan for Extended Bioventing*. Prepared for Air Force Center for Environmental Excellence, Environmental Restoration Technology, USAF Contract F41624-92-D-8036, Delivery Order 17. April.
- US Air Force, 1994. Statement of Work, Title 1 A-E Services for Bioventing Monitoring/Full-Scale Design. Contract No. F41624-92-D-8036, Delivery Order 17. May 26
- US Air Force, 1995. Unpublished site history and data, Eaker AFB, Arkansas.

APPENDIX A
MONITORING WELL AS-BUILT
CONSTRUCTION DIAGRAMS

FIELD WELL COMPLETION FORM

JOB NAME: EAKER AFB

JOB NUMBER: 0114 PROJECT MANAGER: A. JENKINS

LOGGED BY: B. McCANLESS EDITED BY:

WELL NAME: TW1601 DATE: 9/12/95

DRILLING COMPANY: TRI-STATE

EQUIPMENT: 7/4 INCH HOLLOW STEM AUGER DRILLER: J. FLEEGER

INCH ROTARY WASH HOURS DRILLED: 0.75

GALLONS OF WATER USED DURING DRILLING: 1013 GALLONS

METHOD OF DECONTAMINATION PRIOR TO DRILLING: STEAM CLEAN

DEVELOPMENT

METHOD OF DEVELOPMENT: SEE DEVELOPMENT FORM

DEVELOPMENT BEGAN DATE: TIME: DATE:

YIELD:	GPM	TIME: FROM	TO	DATE:
YIELD:	GPM	TIME: FROM	TO	DATE:
YIELD:	GPM	TIME: FROM	TO	DATE:
YIELD:	GPM	TIME: FROM	TO	DATE:

TOTAL WATER REMOVED DURING DEVELOPMENT: GALLONS

DESCRIPTION OF TURBIDITY AT END OF DEVELOPMENT: CLEAR SLIGHTLY CLOUDY MOD. TURBID VERY MUDDY

ODOR OF WATER:

WATER DISCHARGED TO: GROUND SURFACE TANK TRUCK STORM SEWERS STORAGE TANK DRUMS OTHER

DEPTH TO WATER AFTER DEVELOPMENT: FEET

MATERIALS USED

4 1/3 SACKS OF MURIECO FILTRATION SAND OWN

SACKS OF CEMENT

GALLONS OF GROUT USED

SACKS OF POWDERED BENTONITE

62.5 POUNDS OF BENTONITE PELLETS 1 1/4 BUCKETS

10 FEET OF 2 INCH PVC BLANK CASING

10 FEET OF 2 INCH PVC SLOTTED SCREEN

YARD³ CEMENT-SAND (REDI-MIX) ORDERED

YARD³ CEMENT-SAND (REDI-MIX) USED

CONCRETE PUMPER USED? NO YES

NAME

WELL COVER USED: LOCKING STEEL COVER

CHRISTY BOX

OTHER TEMP WELL

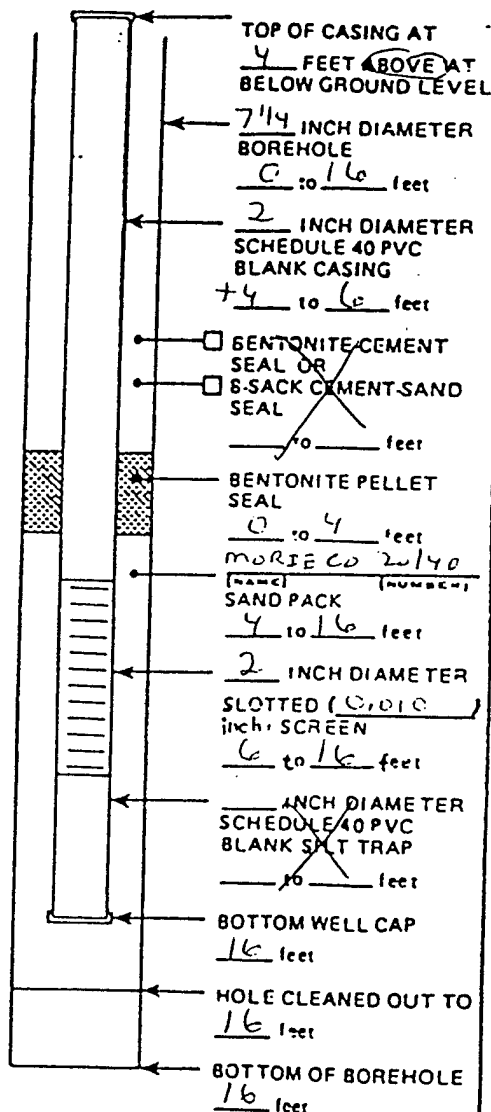
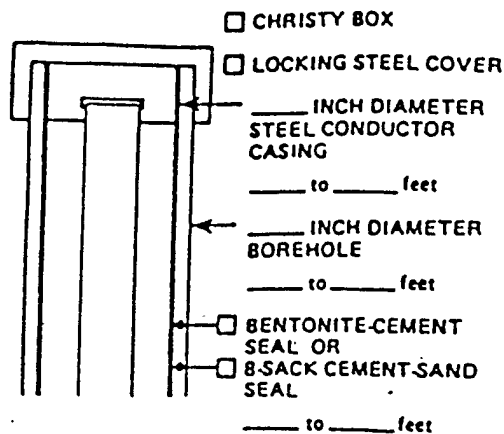

NOT TO SCALE

ADDITIONAL INFORMATION:

SAND CALC: 6 BAGS

FIELD WELL COMPLETION FORM

JOB NAME: EAKER AFB

JOB NUMBER: 0114 PROJECT MANAGER: A. JENKINS

LOGGED BY: B. McLANESS EDITED BY:

WELL NAME: TW1602 DATE: 9/12/95

DRILLING COMPANY: TRI STATE

EQUIPMENT: 7 1/4 INCH HOLLOW STEM AUGER DRILLER: J. FLEGER
 INCH ROTARY WASH HOURS DRILLED: 0.5

GALLONS OF WATER USED DURING DRILLING: _____ GALLONS

METHOD OF DECONTAMINATION PRIOR TO DRILLING: STEAM CLEAN

DEVELOPMENT

METHOD OF DEVELOPMENT: DEVELOPMENT FORM

DEVELOPMENT BEGAN DATE: _____ TIME: _____

YIELD:	GPM	TIME: FROM	TO	DATE:
YIELD:	GPM	TIME: FROM	TO	DATE:
YIELD:	GPM	TIME: FROM	TO	DATE:
YIELD:	GPM	TIME: FROM	TO	DATE:

TOTAL WATER REMOVED DURING DEVELOPMENT: _____ GALLONS

DESCRIPTION OF TURBIDITY AT END OF DEVELOPMENT: CLEAR SLIGHTLY CLOUDY
 MOD. TURBID VERY MUDDY

ODOR OF WATER: _____

WATER DISCHARGED TO: GROUND SURFACE TANK TRUCK
 STORM SEWERS STORAGE TANK
 DRUMS OTHER _____

DEPTH TO WATER AFTER DEVELOPMENT: _____ FEET

MATERIALS USED

3.5 4 SACKS OF MURKIN CO. FILTRATION SAND CON
 _____ SACKS OF _____ CEMENT
 _____ GALLONS OF GROUT USED
 _____ SACKS OF POWDERED BENTONITE
87.5 POUNDS OF BENTONITE PELLETS 1 3/4 BUCKET
10 FEET OF 2 INCH PVC BLANK CASING
10 FEET OF 2 INCH PVC SLOTTED SCREEN

_____ YARD³ CEMENT-SAND (REDI-MIX) ORDERED
 _____ YARD³ CEMENT-SAND (REDI-MIX) USED

CONCRETE PUMPER USED? NO YES

NAME _____

WELL COVER USED: LOCKING STEEL COVER
 CHRISTY BOX
 OTHER TEMP. WELL

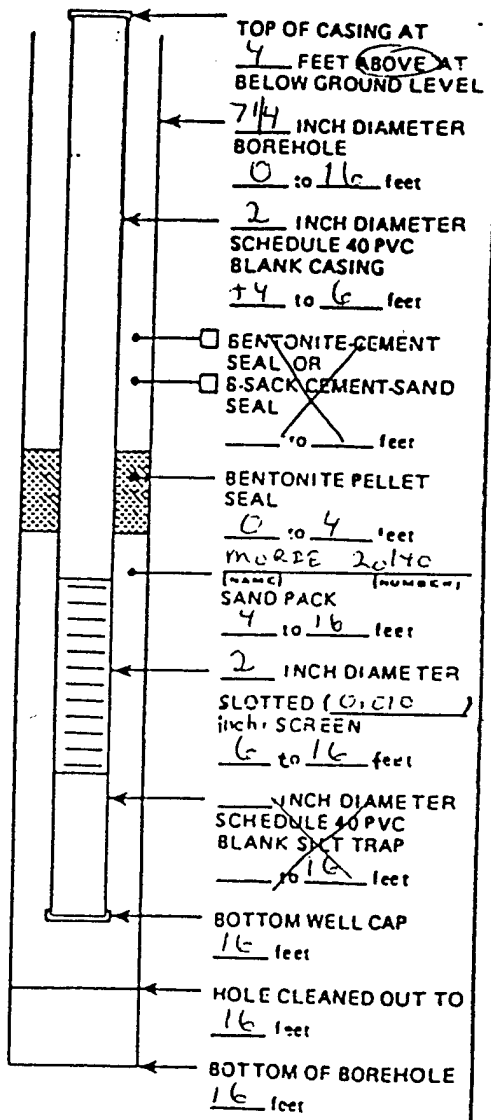
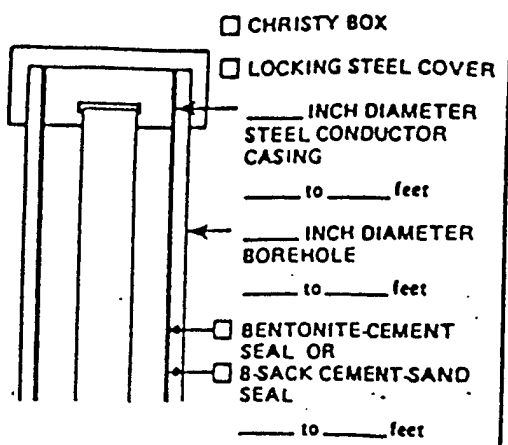

NOT TO SCALE

ADDITIONAL INFORMATION: SAND CALC = 6 BAGS

FIELD WELL COMPLETION FORM

JOB NAME: EAKER AFB

JOB NUMBER: 0114 PROJECT MANAGER: A. JENKINS

LOGGED BY: B. McCANLESS EDITED BY:

WELL NAME: TW1603 DATE: 9/12/95

DRILLING COMPANY: TRI-STATE

EQUIPMENT: 7/4 INCH HOLLOW STEM AUGER DRILLER: J. FLEEGER
 INCH ROTARY WASH HOURS DRILLED: 0.50

GALLONS OF WATER USED DURING DRILLING: 5 GALLONS TD HYDRATE

METHOD OF DECONTAMINATION PRIOR TO DRILLING: STEAM CLEAN PELLETS

DEVELOPMENT

METHOD OF DEVELOPMENT: DEVELOPMENT FORM

DEVELOPMENT BEGAN DATE: _____ TIME: _____ DATE: _____

YIELD:	GPM	TIME: FROM	TO	DATE:

TOTAL WATER REMOVED DURING DEVELOPMENT: _____ GALLONS

DESCRIPTION OF TURBIDITY AT END OF DEVELOPMENT: CLEAR SLIGHTLY CLOUDY
 MOD. TURBID VERY MUDDY

ODOR OF WATER: _____

WATER DISCHARGED TO: GROUND SURFACE TANK TRUCK
 STORM SEWERS STORAGE TANK
 DRUMS OTHER _____

DEPTH TO WATER AFTER DEVELOPMENT: _____ FEET

MATERIALS USED

- 4 SACKS OF MORFEE CO. FILTRATION SAND ^{CON}
- _____ SACKS OF _____ CEMENT
- _____ GALLONS OF GROUT USED
- _____ SACKS OF POWDERED BENTONITE
- 75 POUNDS OF BENTONITE PELLETS 1.5 BUCKETS
- 10 FEET OF 2 INCH PVC BLANK CASING
- 10 FEET OF 2 INCH PVC SLOTTED SCREEN

_____ YARD³ CEMENT-SAND (REDI-MIX) ORDERED
 _____ YARD³ CEMENT-SAND (REDI-MIX) USED

CONCRETE PUMPER USED? NO YES

NAME _____

WELL COVER USED: LOCKING STEEL COVER
 CHRISTY BOX
 OTHER TEMP. WELL

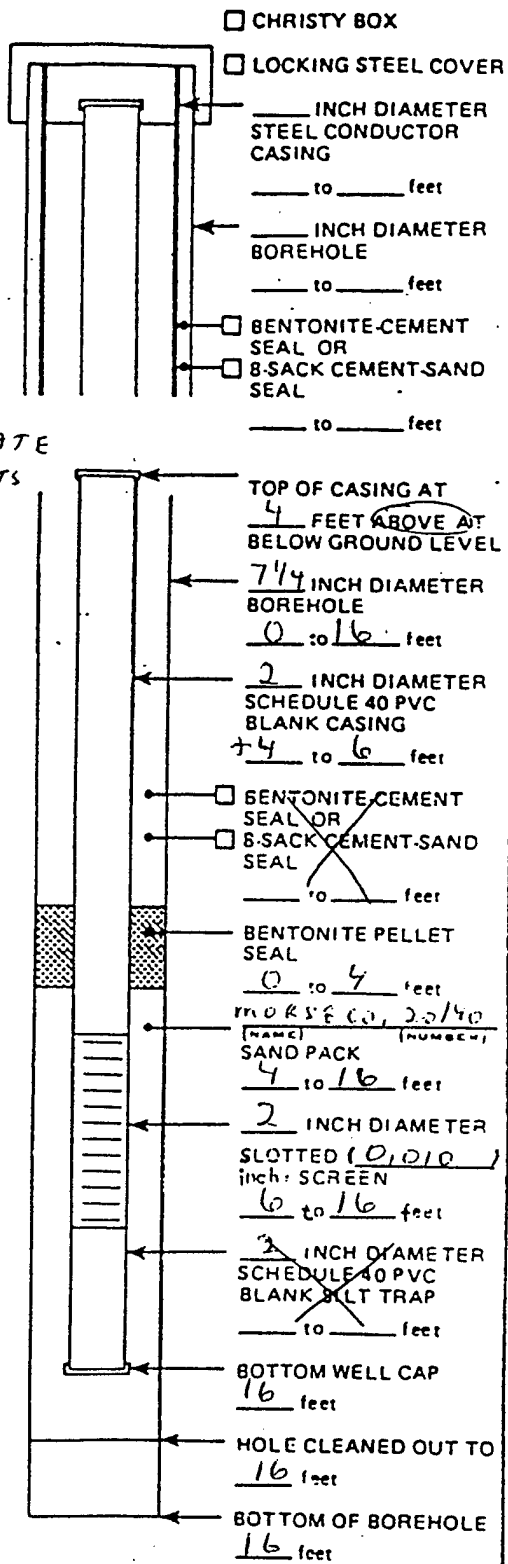

NOT TO SCALE

ADDITIONAL INFORMATION: _____

SAND CALC = 6 BAGS

FIELD WELL COMPLETION FORM

JOB NAME: EAKER AFB A JENKINS
 JOB NUMBER: 0114 PROJECT MANAGER: JOE FLEGER
 LOGGED BY: B. McCANLESS EDITED BY:
 WELL NAME: TW1604 DATE: 9/12/95
 DRILLING COMPANY: TRI-STATE
 EQUIPMENT: 7/4 INCH HOLLOW STEM AUGER DRILLER: J. FLEGER
 INCH ROTARY WASH HOURS DRILLED: 0.5

GALLONS OF WATER USED DURING DRILLING: 20 GALLONS 15 GALS TO SURGE
 METHOD OF DECONTAMINATION PRIOR TO DRILLING: STEAM CLEAN SCALE TO HYDRATE

DEVELOPMENT

METHOD OF DEVELOPMENT: DEVELOPMENT FORM

YIELD:	GPM	TIME: FROM	TO	DATE:
YIELD:	GPM	TIME: FROM	TO	DATE:
YIELD:	GPM	TIME: FROM	TO	DATE:
YIELD:	GPM	TIME: FROM	TO	DATE:

TOTAL WATER REMOVED DURING DEVELOPMENT: _____ GALLONS

DESCRIPTION OF TURBIDITY AT END OF DEVELOPMENT: CLEAR SLIGHTLY CLOUDY
 MOD. TURBID VERY MUDDY

ODOR OF WATER:
 WATER DISCHARGED TO: GROUND SURFACE TANK TRUCK
 STORM SEWERS STORAGE TANK
 DRUMS OTHER

DEPTH TO WATER AFTER DEVELOPMENT: _____ FEET

MATERIALS USED

4.5 SACKS OF MORDECO CON FILTRATION SAND
 _____ SACKS OF _____ CEMENT
 _____ GALLONS OF GROUT USED
 _____ SACKS OF POWDERED BENTONITE
50 POUNDS OF BENTONITE PELLETS 1 BUCKET
10 FEET OF 2 INCH PVC BLANK CASING
10 FEET OF 2 INCH PVC SLOTTED SCREEN

_____ YARD³ CEMENT-SAND (REDI-MIX) ORDERED
 _____ YARD³ CEMENT-SAND (REDI-MIX) USED

CONCRETE PUMPER USED? NO YES

NAME _____

WELL COVER USED: LOCKING STEEL COVER
 CHRISTY BOX
 OTHER TEMP WELL

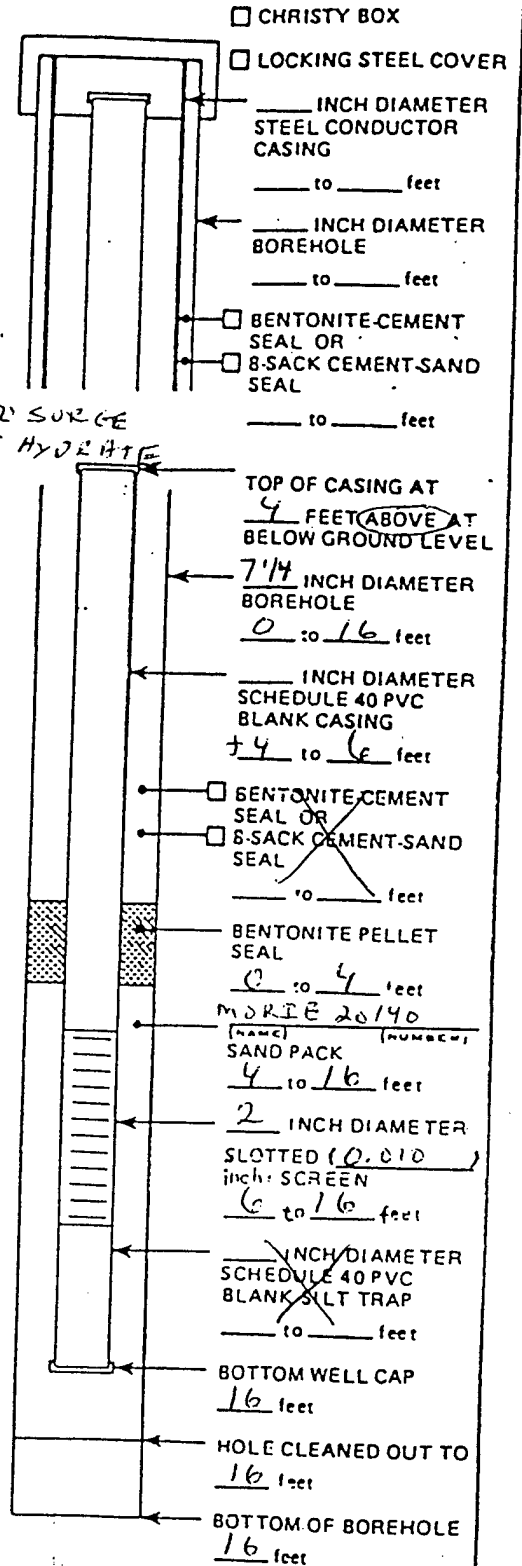

NOT TO SCALE

ADDITIONAL INFORMATION: SAND CALC = 6 BAGS



FIELD WELL COMPLETION FORM

JOB NAME: BAFB JP-1 site

JOB NUMBER: LS99 PROJECT MANAGER: J Nelson

LOGGED BY: R. Jenkins EDITED BY: J. Lewis

WELL NAME: MW-201 DATE: 4/28

DRILLING COMPANY: A.W. Pool

EQUIPMENT: 7/4 INCH HOLLOW STEM AUGER DRILLER: G. Pool
 INCH ROTARY WASH HOURS DRILLED: _____

GALLONS OF WATER USED DURING DRILLING: 0 GALLONS

METHOD OF DECONTAMINATION PRIOR TO DRILLING: pressure steam clean

DEVELOPMENT

METHOD OF DEVELOPMENT: balling

YIELD:	GPM	TIME: FROM	TO	DATE:

TOTAL WATER REMOVED DURING DEVELOPMENT: _____ GALLONS

DESCRIPTION OF TURBIDITY AT END OF DEVELOPMENT: CLEAR SLIGHTLY CLOUDY
 MOD. TURBID VERY MUDDY

ODOR OF WATER: _____

WATER DISCHARGED TO: GROUND SURFACE TANK TRUCK
 STORM SEWERS STORAGE TANK
 DRUMS OTHER _____

DEPTH TO WATER AFTER DEVELOPMENT: _____ FEET

MATERIALS USED

- 3 SACKS OF 12-28 SAND 25.1
- _____ SACKS OF Port. Type II CEMENT - 3.6
- _____ GALLONS OF GROUT USED 22.1
- _____ SACKS OF POWDERED BENTONITE
- 25 POUNDS OF BENTONITE PELLETS
- 10.5 FEET OF 2 INCH PVC BLANK CASING
- 15 FEET OF 2 INCH PVC SLOTTED SCREEN
- 1 - 0.1' screw on bott. cap

_____ YARD³ CEMENT-SAND (REDI-MIX) ORDERED

_____ YARD³ CEMENT-SAND (REDI-MIX) USED

CONCRETE PUMPER USED? NO YES

NAME _____

WELL COVER USED: LOCKING STEEL COVER
 CHRISTY BOX
 OTHER _____

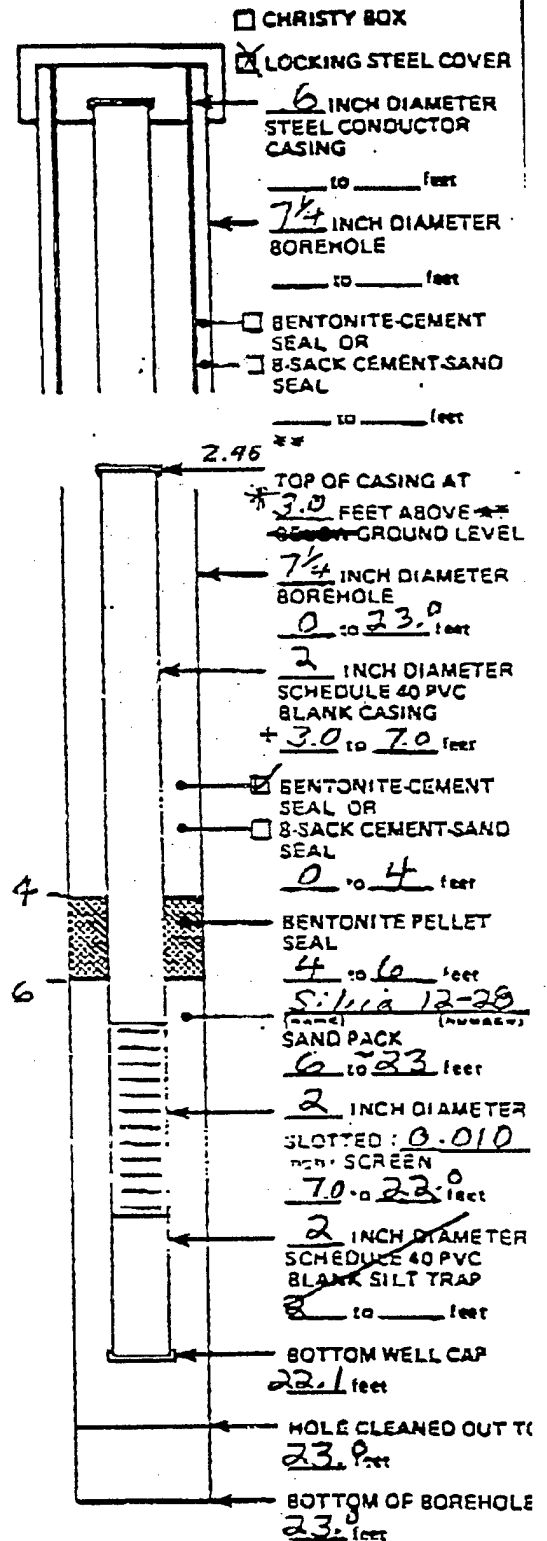

NOT TO SCALE

ADDITIONAL INFORMATION: riser + screen steam cleaned

* prior to cut-off



FIELD WELL COMPLETION FORM

JOB NAME: BAFB JP-1 site

JOB NUMBER: LS99 PROJECT MANAGER: J. Nelson

LOGGED BY: A. Jenkins EDITED BY: J. Lewis

WELL NAME: MW-202 DATE: 4/28

DRILLING COMPANY: A.W. Pool

EQUIPMENT: 7/4 INCH HOLLOW STEM AUGER DRILLER: G. Pool
 INCH ROTARY WASH HOURS DRILLED:

GALLONS OF WATER USED DURING DRILLING: 0 GALLONS

METHOD OF DECONTAMINATION PRIOR TO DRILLING: pressure steam cleaning

DEVELOPMENT METHOD OF DEVELOPMENT: bailing

YIELD:	GPM	TIME:	DATE:
		FROM TO	

TOTAL WATER REMOVED DURING DEVELOPMENT: _____ GALLONS

DESCRIPTION OF TURBIDITY AT END OF DEVELOPMENT: CLEAR SLIGHTLY CLOUDY MOD. TURBID VERY MUDDY

ODOR OF WATER:

WATER DISCHARGED TO: GROUND SURFACE TANK TRUCK STORM SEWERS STORAGE TANK DRUMS OTHER

DEPTH TO WATER AFTER DEVELOPMENT: _____ FEET

MATERIALS USED

3 SACKS OF 12-28 SAND

_____ SACKS OF Port. Type II CEMENT

_____ GALLONS OF GROUT USED

_____ SACKS OF POWDERED BENTONITE

25 POUNDS OF BENTONITE PELLETS

10 FEET OF 2 INCH PVC BLANK CASING

15 FEET OF 2 INCH PVC SLOTTED SCREEN

1-0.1' screw on bott. cap

_____ YARD³ CEMENT-SAND (REDI-MIX) ORDERED

_____ YARD³ CEMENT-SAND (REDI-MIX) USED

CONCRETE PUMPER USED? NO YES

NAME _____

WELL COVER USED: LOCKING STEEL COVER CHRISTY BOX OTHER

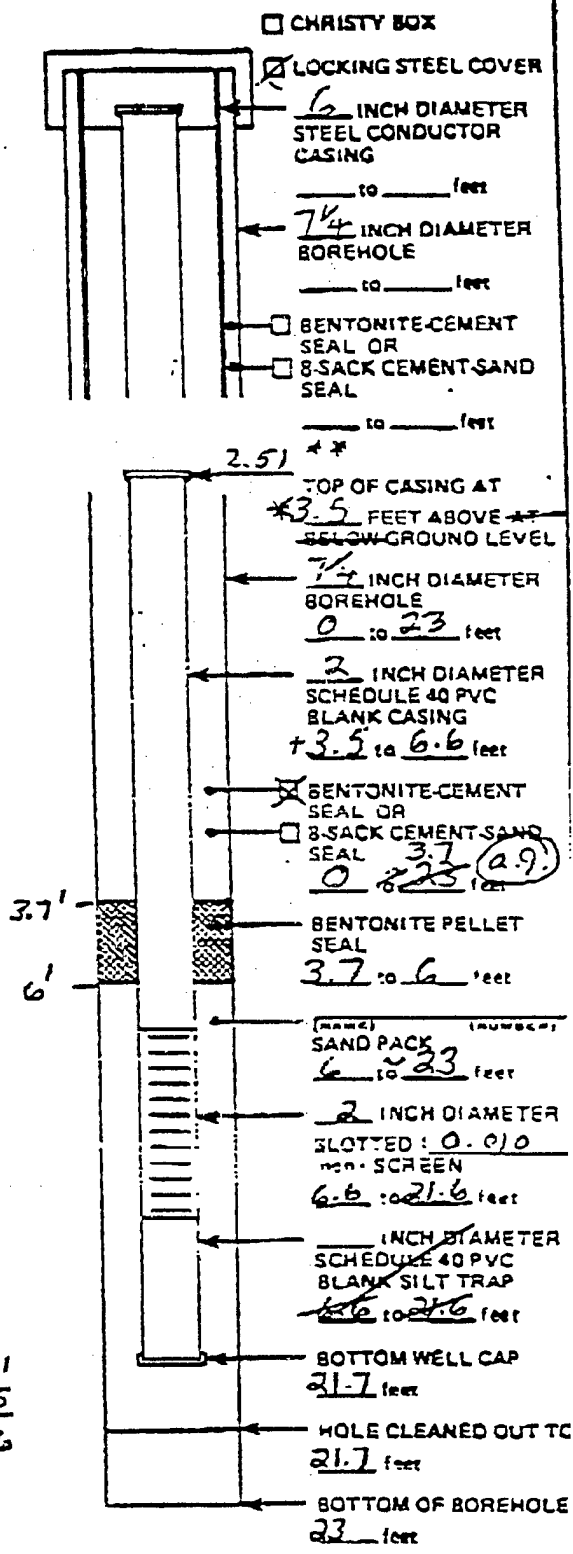

NOT TO SCALE

ADDITIONAL INFORMATION: riser + screen steam cleaned

* prior to cut-off



FIELD WELL COMPLETION FORM

JOB NAME: BAFB Site JP-1

JOB NUMBER: LS99 PROJECT MANAGER: J. Nelson

LOGGED BY: A. Jenkins EDITED BY: J. Lewis

WELL NAME: MW 203 DATE: 4/29/89

DRILLING COMPANY: A.W. Pool

EQUIPMENT: 7/4 INCH HOLLOW STEM AUGER DRILLER: G. Pool
 INCH ROTARY WASH HOURS DRILLED: _____

CALLONS OF WATER USED DURING DRILLING: 0 GALLONS

METHOD OF DECONTAMINATION PRIOR TO DRILLING: pressure steam

DEVELOPMENT

METHOD OF DEVELOPMENT: bailing

YIELD:	TIME:	DATE:
GPM	FROM TO	

TOTAL WATER REMOVED DURING DEVELOPMENT: _____ GALLONS

DESCRIPTION OF TURBIDITY AT END OF DEVELOPMENT: CLEAR SLIGHTLY CLOUDY
 MOD. TURBID VERY MUDDY

ODOR OF WATER: _____

WATER DISCHARGED TO: GROUND SURFACE TANK TRUCK
 STORM SEWERS STORAGE TANK
 DRUMS OTHER _____

DEPTH TO WATER AFTER DEVELOPMENT: _____ FEET

MATERIALS USED

- 5 SACKS OF 12-28 SAND
- _____ SACKS OF Port. Type II CEMENT
- _____ GALLONS OF GROUT USED
- _____ SACKS OF POWDERED BENTONITE
- 25 POUNDS OF BENTONITE PELLETS 25.1
- 10 FEET OF 2 INCH PVC BLANK CASING - 4
- 15 FEET OF 2 INCH PVC SLOTTED SCREEN 21.1
- 1-0.1' spec on bott. cap
- _____ YARD³ CEMENT-SAND (REDI-MIX) ORDERED
- _____ YARD³ CEMENT-SAND (REDI-MIX) USED
- CONCRETE PUMPER USED? NO YES
- NAME _____

WELL COVER USED: LOCKING STEEL COVER
 CHRISTY BOX

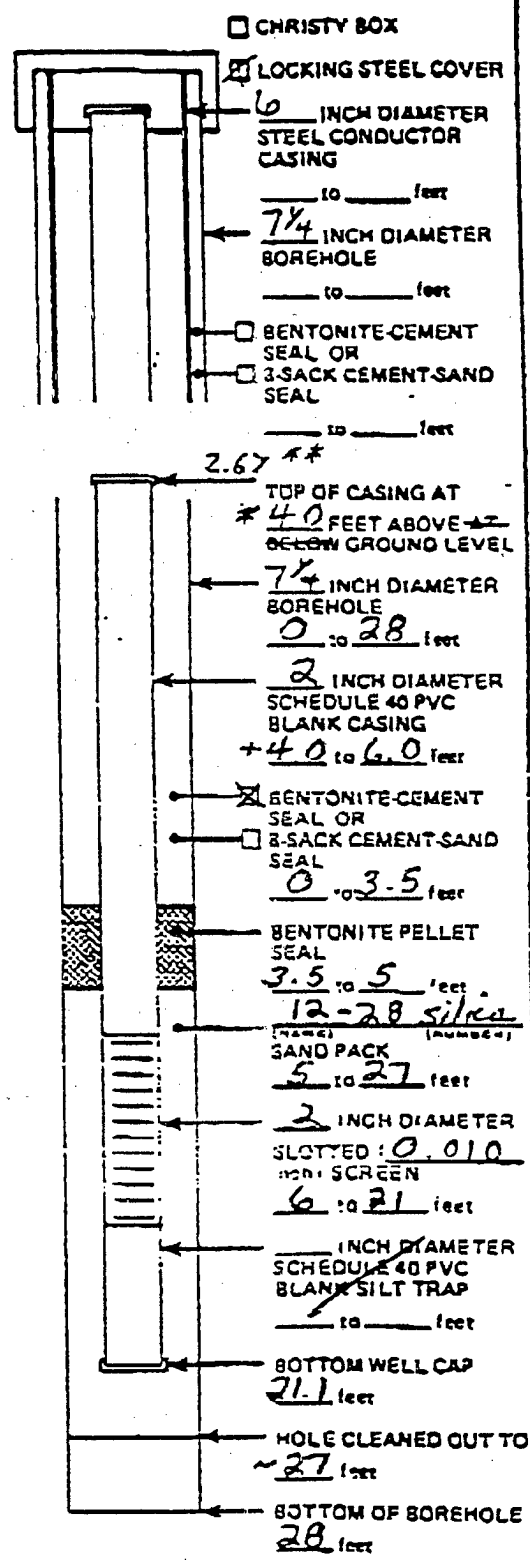

NOT TO SCALE

ADDITIONAL INFORMATION: _____

* prior to cut-off

** After 1.33' cut off and survey completed.

FIELD WELL COMPLETION FORM

JOB NAME: Eaker AFB

JOB NUMBER: 0114 PROJECT MANAGER: AJ

LOGGED BY: BDH EDITED BY:

WELL NAME: MW205 DATE: 4/19/95

DRILLING COMPANY: Tri-state Testing

EQUIPMENT: 7/4 INCH HOLLOW STEM AUGER DRILLER: Joe T. Lopez
 INCH ROTARY WASH HOURS DRILLED:

GALLONS OF WATER USED DURING DRILLING: NA GALLONS

METHOD OF DECONTAMINATION PRIOR TO DRILLING: Steam Clean

DEVELOPMENT

METHOD OF DEVELOPMENT: See Well Development Form

YIELD:	GPM	TIME:	FROM	TO	DATE:
YIELD:	GPM	TIME:	FROM	TO	DATE:
YIELD:	GPM	TIME:	FROM	TO	DATE:
YIELD:	GPM	TIME:	FROM	TO	DATE:

TOTAL WATER REMOVED DURING DEVELOPMENT: _____ GALLONS

DESCRIPTION OF TURBIDITY AT END OF DEVELOPMENT: CLEAR SLIGHTLY CLOUDY
 MOD. TURBID VERY MUDDY

ODOR OF WATER:

WATER DISCHARGED TO: GROUND SURFACE TANK TRUCK
 STORM SEWERS STORAGE TANK
 DRUMS OTHER _____

DEPTH TO WATER AFTER DEVELOPMENT: _____ FEET

MATERIALS USED

10.5 SACKS OF 20/40 2 1/2 bag mine SAND

_____ SACKS OF _____ CEMENT

_____ GALLONS OF GROUT USED

_____ SACKS OF POWDERED BENTONITE

75 POUNDS OF BENTONITE PELLETS

11.7 FEET OF 2 INCH PVC BLANK CASING

10.0 FEET OF 2 INCH PVC SLOTTED SCREEN

2.0 feet of 2 inch 25 sub trap

_____ YARD³ CEMENT-SAND (REDI-MIX) ORDERED

_____ YARD³ CEMENT-SAND (REDI-MIX) USED

CONCRETE PUMPER USED? NO YES

NAME _____

WELL COVER USED: LOCKING STEEL COVER
 CHRISTY BOX
 OTHER _____

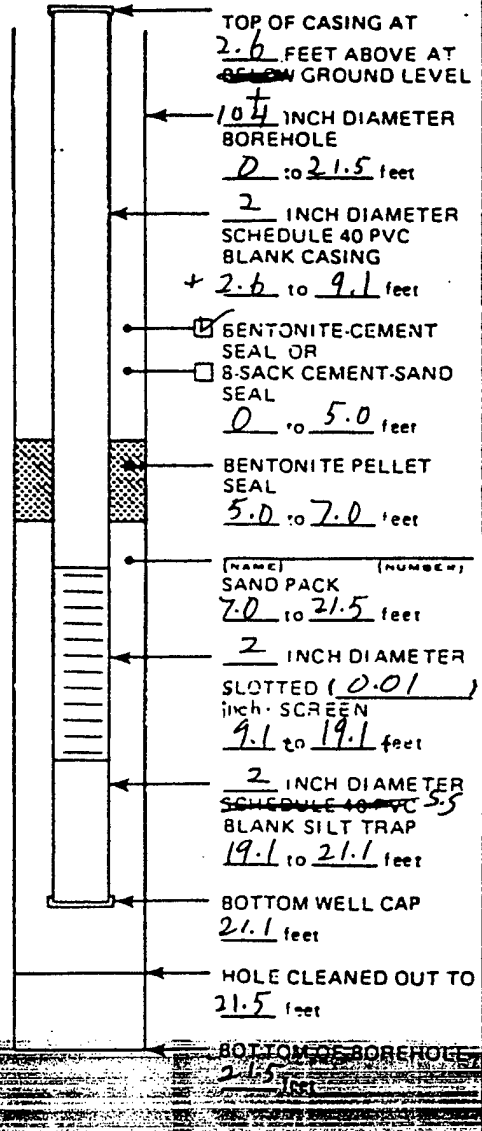
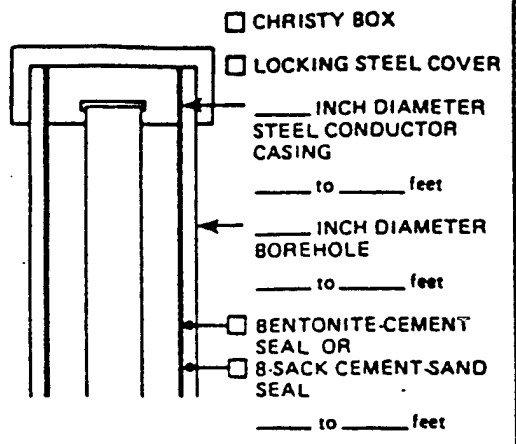

NOT TO SCALE

ADDITIONAL INFORMATION: _____

FIELD WELL COMPLETION FORM

JOB NAME: Leaher AFB

JOB NUMBER: 0114 PROJECT MANAGER: AT

LOGGED BY: BDH EDITED BY:

WELL NAME: MW206 DATE: 4/12/95

DRILLING COMPANY: Tri-State Testing

EQUIPMENT: 1 1/4 ID INCH HOLLOW STEM AUGER DRILLER: Joe T. Egger
 INCH ROTARY WASH HOURS DRILLED:

GALLONS OF WATER USED DURING DRILLING: NA GALLONS NA

METHOD OF DECONTAMINATION PRIOR TO DRILLING: Bean Cleaner

DEVELOPMENT

METHOD OF DEVELOPMENT:

DEVELOPMENT BEGAN DATE: TIME: DATE:

YIELD:	GPM	TIME:	TO	DATE:
		FROM		
YIELD:	GPM	TIME:	TO	DATE:
		FROM		
YIELD:	GPM	TIME:	TO	DATE:
		FROM		
YIELD:	GPM	TIME:	TO	DATE:
		FROM		

TOTAL WATER REMOVED DURING DEVELOPMENT: _____ GALLONS

DESCRIPTION OF TURBIDITY AT END OF DEVELOPMENT: CLEAR SLIGHTLY CLOUDY
 MOD. TURBID VERY MUDDY

ODOR OF WATER:

WATER DISCHARGED TO: GROUND SURFACE TANK TRUCK
 STORM SEWERS STORAGE TANK
 DRUMS OTHER _____

DEPTH TO WATER AFTER DEVELOPMENT: _____ FEET

MATERIALS USED

10 1/2 SACKS OF 50lb 20/40 Marie SAND

_____ SACKS OF _____ CEMENT

_____ GALLONS OF GROUT USED

_____ SACKS OF POWDERED BENTONITE

100 POUNDS OF BENTONITE PELLETS

13.5 FEET OF 2 INCH PVC BLANK CASING

10.0 FEET OF 2 INCH PVC SLOTTED SCREEN 5.5

2.0 feet of 2 inch 5.5 slot screen

_____ YARD³ CEMENT-SAND (REDI-MIX) ORDERED

_____ YARD³ CEMENT-SAND (REDI-MIX) USED

CONCRETE PUMPER USED? NO YES

NAME _____

WELL COVER USED: LOCKING STEEL COVER
 CHRISTY BOX
 OTHER _____

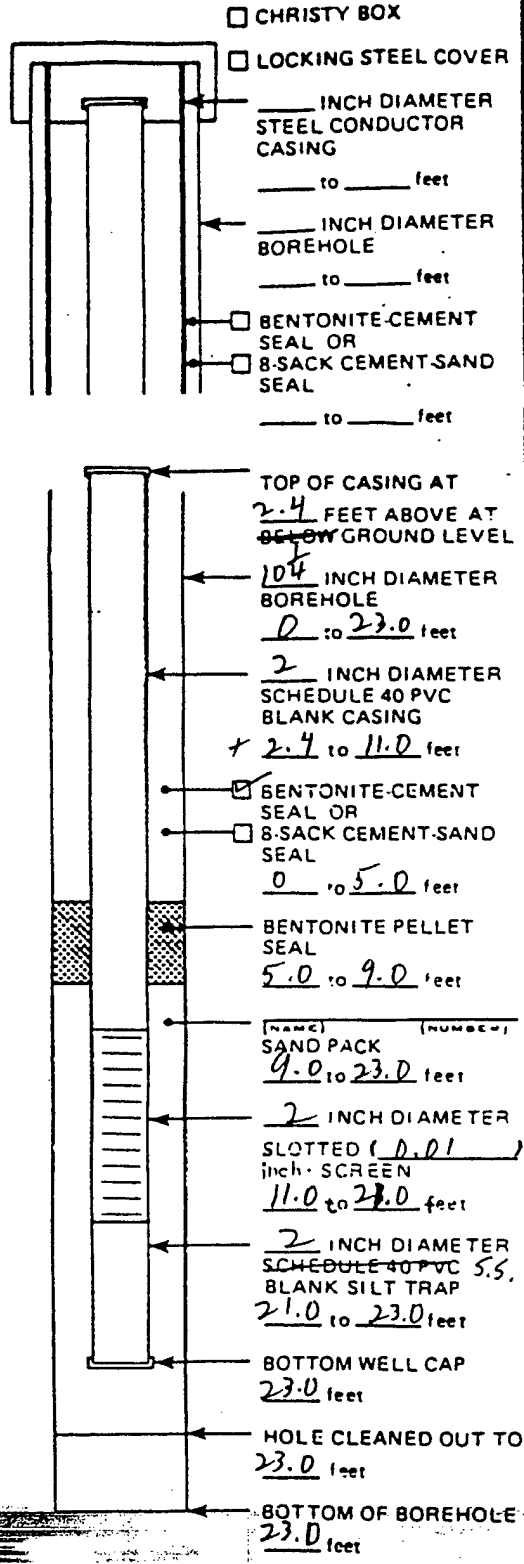

NOT TO SCALE

ADDITIONAL INFORMATION: _____

FIELD WELL COMPLETION FORM

JOB NAME: Edger AFB

JOB NUMBER: 0114 PROJECT MANAGER: AT

LOGGED BY: B0H EDITED BY:

WELL NAME: MW207 DATE: 4/10/95

DRILLING COMPANY: Tri-state Drilling

EQUIPMENT: 7 1/2 INCH HOLLOW STEM AUGER DRILLER: Joe F. Boyer

INCH ROTARY WASH HOURS DRILLED:

GALLONS OF WATER USED DURING DRILLING: NA GALLONS

METHOD OF DECONTAMINATION PRIOR TO DRILLING: Steam Cleaner

DEVELOPMENT

METHOD OF DEVELOPMENT:

YIELD:	GPM	TIME: FROM	TO	DATE:

TOTAL WATER REMOVED DURING DEVELOPMENT: _____ GALLONS

DESCRIPTION OF TURBIDITY AT END OF DEVELOPMENT: CLEAR SLIGHTLY CLOUDY MOD. TURBID VERY MUDDY

ODOR OF WATER:

WATER DISCHARGED TO: GROUND SURFACE TANK TRUCK STORM SEWERS STORAGE TANK DRUMS OTHER _____

DEPTH TO WATER AFTER DEVELOPMENT: _____ FEET

MATERIALS USED

9 1/2 SACKS OF 50 lb 20/40 mesh SAND

_____ SACKS OF _____ CEMENT

_____ GALLONS OF GROUT USED

_____ SACKS OF POWDERED BENTONITE

75 POUNDS OF BENTONITE PELLETS

14.1 FEET OF 2 INCH PVC BLANK CASING

10.0 FEET OF 2 INCH PVC SLOTTED SCREEN ^{S.S.}

2.0 feet of 2 inch SS silt trap

_____ YARD³ CEMENT-SAND (REDI-MIX) ORDERED

_____ YARD³ CEMENT-SAND (REDI-MIX) USED

CONCRETE PUMPER USED? NO YES

NAME _____

WELL COVER USED: LOCKING STEEL COVER CHRISTY BOX OTHER _____

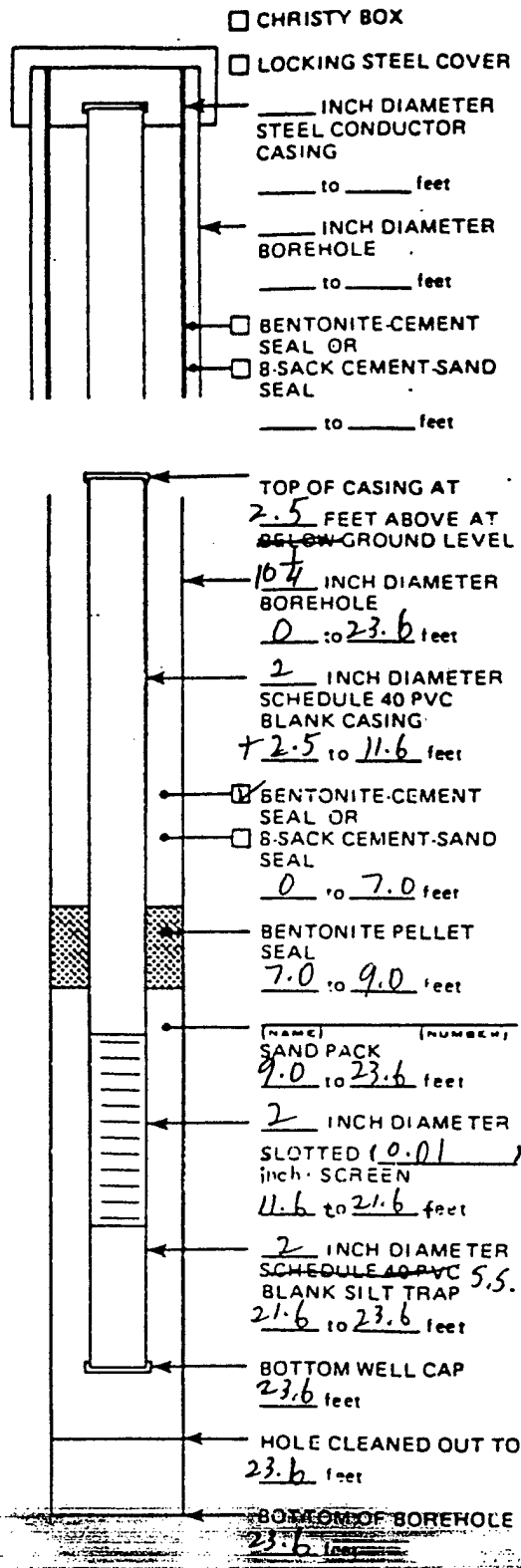

NOT TO SCALE

ADDITIONAL INFORMATION: _____

FIELD WELL COMPLETION FORM

JOB NAME: Eaker AFB
 JOB NUMBER: 0114 PROJECT MANAGER: Allan Jenkins
 LOGGED BY: G. Millar EDITED BY:
 WELL NAME: MW 211 DATE: 8/15/95
 DRILLING COMPANY: Tri State Testing Services
 EQUIPMENT: 10 INCH HOLLOW STEM AUGER DRILLER: J. Crawford
 INCH ROTARY WASH HOURS DRILLED:

GALLONS OF WATER USED DURING DRILLING: _____ GALLONS

METHOD OF DECONTAMINATION PRIOR TO DRILLING: Steam Clearing

DEVELOPMENT Well Development Form

METHOD OF DEVELOPMENT:

YIELD:	GPM	TIME: FROM	TO	DATE:
YIELD:	GPM	TIME: FROM	TO	DATE:
YIELD:	GPM	TIME: FROM	TO	DATE:
YIELD:	GPM	TIME: FROM	TO	DATE:

TOTAL WATER REMOVED DURING DEVELOPMENT: _____ GALLONS

DESCRIPTION OF TURBIDITY AT END OF DEVELOPMENT: CLEAR SLIGHTLY CLOUDY
 MOD. TURBID VERY MUDDY

ODOR OF WATER:

WATER DISCHARGED TO: GROUND SURFACE TANK TRUCK
 STORM SEWERS STORAGE TANK
 DRUMS OTHER

DEPTH TO WATER AFTER DEVELOPMENT: _____ FEET

MATERIALS USED

- 072495 GA DONNELL
- 11 SACKS OF Morie 2040 Filtration Media SAND
- _____ SACKS OF _____ CEMENT
- 20 GALLONS OF GROUT USED
- _____ SACKS OF POWDERED BENTONITE
- 750.50 POUNDS OF BENTONITE PELLETS 1 1/2 buckets
- 15 FEET OF 2 INCH PVC BLANK CASING w/ 2.5 ft. cutoff.
- 10 FEET OF 2 INCH S.S. SLOTTED SCREEN
- 2 FT of 2 inch S.S. silt trap

_____ YARD³ CEMENT-SAND (REDI-MIX) ORDERED
 _____ YARD³ CEMENT-SAND (REDI-MIX) USED

CONCRETE PUMPER USED? NO YES
 NAME mixed in a 55 gal.

WELL COVER USED: LOCKING STEEL COVER
 CHRISTY BOX
 OTHER

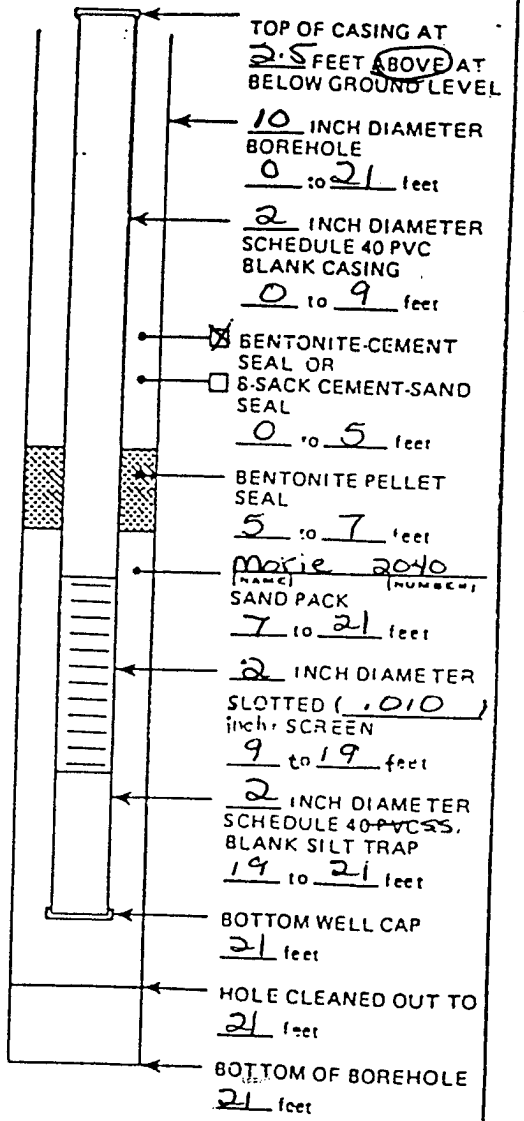
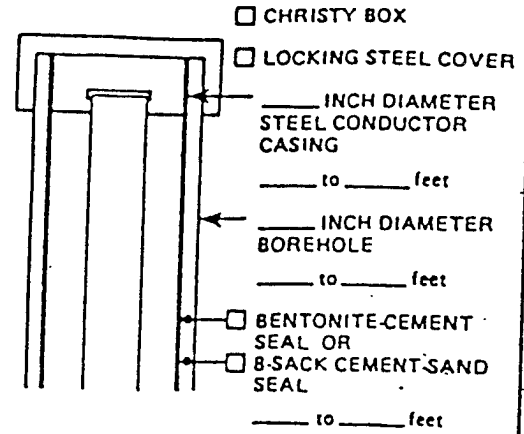

NOT TO SCALE
 ADDITIONAL INFORMATION: _____
Calculated sand = 10.92 sacks
Calculated grout = 19.6 gal

FIELD WELL COMPLETION FORM

JOB NAME: Eaker AFB

JOB NUMBER: 0114 PROJECT MANAGER: Allan Jenkins

LOGGED BY: G. Millar EDITED BY:

WELL NAME: TW1501 DATE: 8/27/95

DRILLING COMPANY: Tri State Testing Services

EQUIPMENT: 5/4 INCH HOLLOW STEM AUGER DRILLER: M. ToHy

INCH ROTARY WASH HOURS DRILLED:

GALLONS OF WATER USED DURING DRILLING: 5 GALLONS

METHOD OF DECONTAMINATION PRIOR TO DRILLING: Steam Cleaning

DEVELOPMENT See Well Development Form

METHOD OF DEVELOPMENT:

DEVELOPMENT BEGAN DATE: TIME: DATE:

YIELD:	GPM	TIME:	DATE:
		FROM TO	
YIELD:	GPM	TIME: FROM TO	DATE:
YIELD:	GPM	TIME: FROM TO	DATE:
YIELD:	GPM	TIME: FROM TO	DATE:

TOTAL WATER REMOVED DURING DEVELOPMENT: _____ GALLONS

DESCRIPTION OF TURBIDITY AT END OF DEVELOPMENT: CLEAR SLIGHTLY CLOUDY MOD. TURBID VERY MUDDY

ODOR OF WATER:

WATER DISCHARGED TO: GROUND SURFACE TANK TRUCK STORM SEWERS STORAGE TANK DRUMS OTHER _____

DEPTH TO WATER AFTER DEVELOPMENT: _____ FEET

- MATERIALS USED**
- 5 3/4 SACKS OF _____ SAND
 - NA SACKS OF _____ CEMENT
 - NA GALLONS OF GROUT USED
 - NA SACKS OF POWDERED BENTONITE
 - 75 POUNDS OF BENTONITE PELLETS 1.5 buckets
 - 10 FEET OF 2 INCH PVC BLANK CASING 1 Ft of cut off
 - 10 FEET OF 2 INCH PVC SLOTTED SCREEN

_____ YARD³ CEMENT-SAND (REDI-MIX) ORDERED

_____ YARD³ CEMENT-SAND (REDI-MIX) USED

CONCRETE PUMPER USED? NO YES

NAME _____

WELL COVER USED: LOCKING STEEL COVER CHRISTY BOX OTHER Temp Well

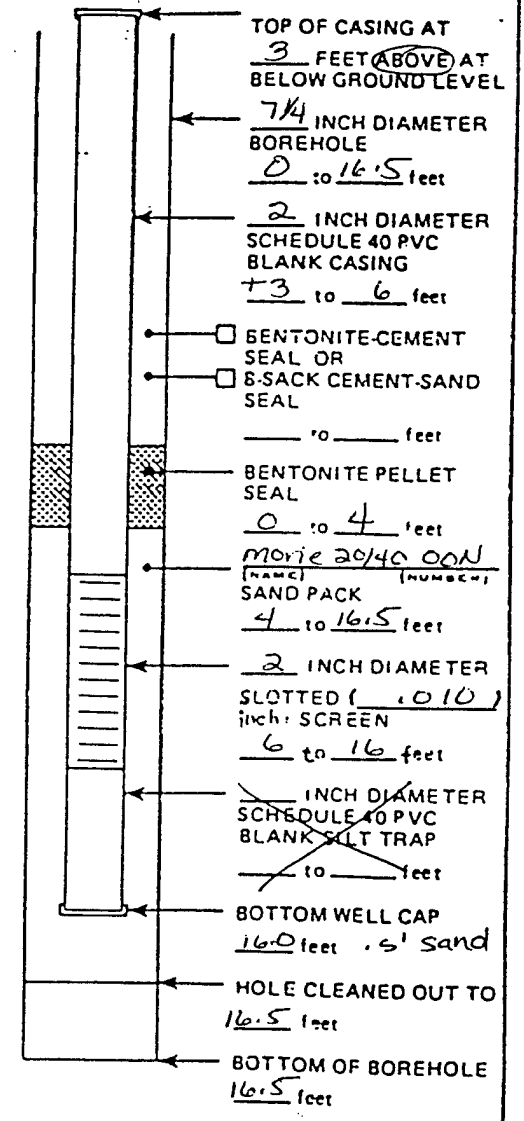
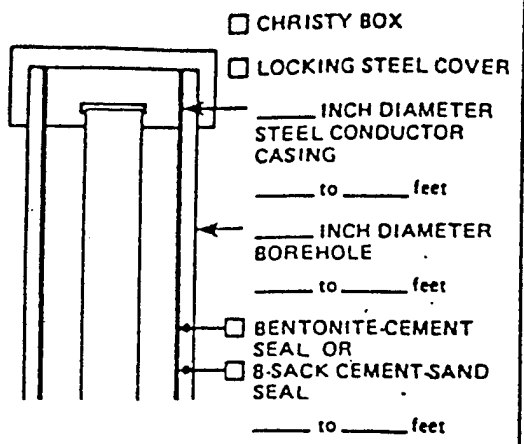

NOT TO SCALE

ADDITIONAL INFORMATION: calculated sand = 6.25 bags

FIELD WELL COMPLETION FORM

JOB NAME: EAKER AFB

JOB NUMBER: 0114 PROJECT MANAGER: ALLAN JENKINS

LOGGED BY: B. McCANLESS EDITED BY:

WELL NAME: TW1502 DATE: 8/28/95

DRILLING COMPANY: TRI STATE TESTING

EQUIPMENT: 7 1/4 INCH HOLLOW STEM AUGER DRILLER: M. DOTTY
 INCH ROTARY WASH HOURS DRILLED: 1

GALLONS OF WATER USED DURING DRILLING: 5 GALLONS

METHOD OF DECONTAMINATION PRIOR TO DRILLING: STEAM CLEAN

DEVELOPMENT

METHOD OF DEVELOPMENT: SEE DEVELOPMENT FORM

DEVELOPMENT BEGAN DATE: _____ TIME: _____

YIELD:	GPM	TIME: FROM	TO	DATE:

TOTAL WATER REMOVED DURING DEVELOPMENT: _____ GALLONS

DESCRIPTION OF TURBIDITY AT END OF DEVELOPMENT: CLEAR SLIGHTLY CLOUDY
 MOD. TURBID VERY MUDDY

ODOR OF WATER: _____

WATER DISCHARGED TO: GROUND SURFACE TANK TRUCK
 STORM SEWERS STORAGE TANK
 DRUMS OTHER _____

DEPTH TO WATER AFTER DEVELOPMENT: _____ FEET

MATERIALS USED

- 5 SACKS OF MORIE CO. FILTRATION SAND ^{MEOIA}
- NA SACKS OF _____ CEMENT
- NA GALLONS OF GROUT USED
- NA SACKS OF POWDERED BENTONITE
- 87 POUNDS OF BENTONITE PELLETS 1.34 BUCKETS
- 10 FEET OF 2 INCH PVC BLANK CASING
- 10 FEET OF 2 INCH PVC SLOTTED SCREEN

_____ YARD³ CEMENT-SAND (REDI-MIX) ORDERED

_____ YARD³ CEMENT-SAND (REDI-MIX) USED

CONCRETE PUMPER USED? NO YES

NAME _____

WELL COVER USED: LOCKING STEEL COVER
 CHRISTY BOX
 OTHER TEMPORARY WELL

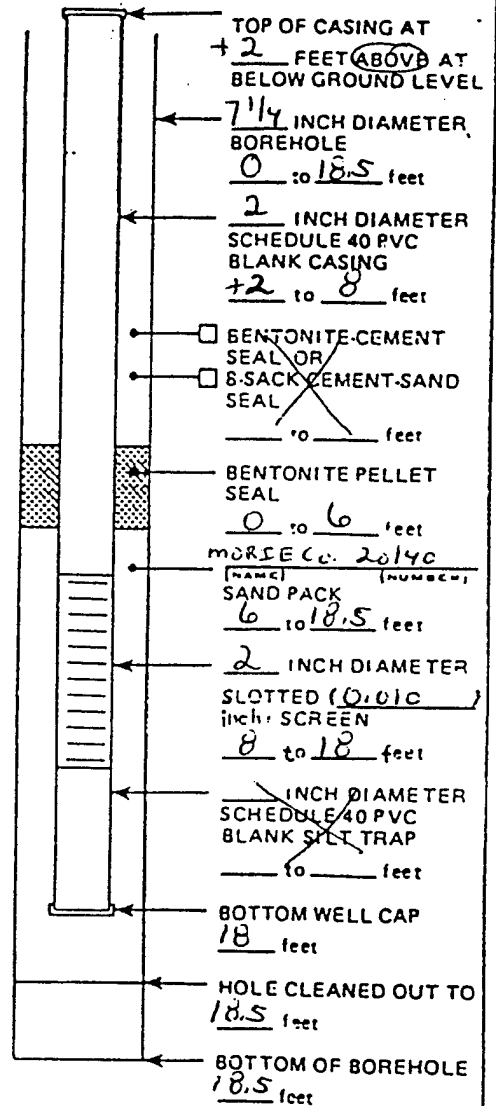
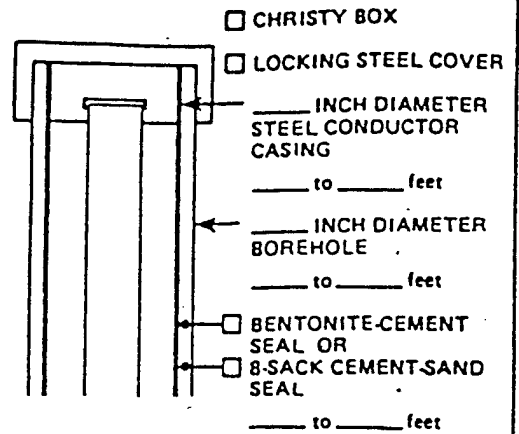

NOT TO SCALE

ADDITIONAL INFORMATION: _____
CALCULATED SAND =
6.25 BAGS

FIELD WELL COMPLETION FORM

JOB NAME: Eaker AFB

JOB NUMBER: 0114 PROJECT MANAGER: Allan Jenkins

LOGGED BY: G. Millar EDITED BY:

WELL NAME: TW1503 DATE: 8/27/95

DRILLING COMPANY: Tri state Testing Services

EQUIPMENT: 7/4 INCH HOLLOW STEM AUGER DRILLER: M. Totty
 INCH ROTARY WASH HOURS DRILLED:

GALLONS OF WATER USED DURING DRILLING: 5 GALLONS to hydrate

METHOD OF DECONTAMINATION PRIOR TO DRILLING: Steam Cleaning

DEVELOPMENT See Well Development Form

METHOD OF DEVELOPMENT:

YIELD:	GPM	TIME: FROM	TO	DATE:

TOTAL WATER REMOVED DURING DEVELOPMENT: _____ GALLONS

DESCRIPTION OF TURBIDITY AT END OF DEVELOPMENT: CLEAR SLIGHTLY CLOUDY
 MOD. TURBID VERY MUDDY

ODOR OF WATER:

WATER DISCHARGED TO: GROUND SURFACE TANK TRUCK
 STORM SEWERS STORAGE TANK
 DRUMS OTHER _____

DEPTH TO WATER AFTER DEVELOPMENT: _____ FEET

- MATERIALS USED**
- 5 1/16 SACKS OF 072495 GACGN WELL More 2040 Filtration media SAND
 - _____ SACKS OF _____ CEMENT
 - _____ GALLONS OF GROUT USED
 - _____ SACKS OF POWDERED BENTONITE
 - 75 POUNDS OF BENTONITE PELLETS 1 1/2 buckets
 - 10 FEET OF 2 INCH PVC BLANK CASING 1.5' cut off
 - 10 FEET OF 2 INCH PVC SLOTTED SCREEN

_____ YARD³ CEMENT-SAND (REDI-MIX) ORDERED
 _____ YARD³ CEMENT-SAND (REDI-MIX) USED
 CONCRETE PUMPER USED? NO YES

NAME _____

WELL COVER USED: LOCKING STEEL COVER
 CHRISTY BOX
 OTHER Temp Well

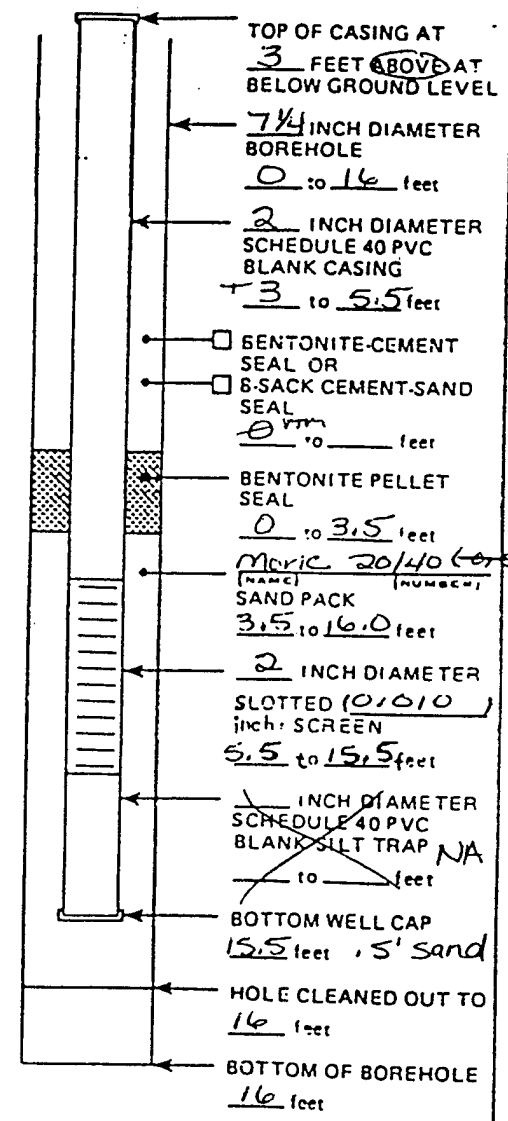
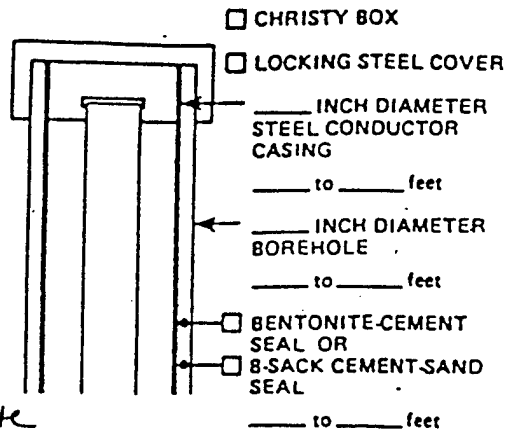

NOT TO SCALE

ADDITIONAL INFORMATION: _____
Calculated Sand = 612 sacks

FIELD WELL COMPLETION FORM

JOB NAME: EAKER AFB
 JOB NUMBER: 0114 PROJECT MANAGER: ALLAN JENKINS
 LOGGED BY: B. MCCANLESS EDITED BY:

WELL NAME: TWIS04 DATE: 8/27/95

DRILLING COMPANY: TRISTATE TESTING

EQUIPMENT: 7/4 INCH HOLLOW STEM AUGER DRILLER: M. DOTY
 INCH ROTARY WASH HOURS DRILLED:

CALLONS OF WATER USED DURING DRILLING: 8 GALLONS

METHOD OF DECONTAMINATION PRIOR TO DRILLING: STEAM CLEAN

DEVELOPMENT

METHOD OF DEVELOPMENT: SEE DEVELOPMENT FORM

DEVELOPMENT BEGAN DATE: TIME:

YIELD:	GPM	TIME: FROM	TO	DATE:

TOTAL WATER REMOVED DURING DEVELOPMENT: GALLONS

DESCRIPTION OF TURBIDITY AT END OF DEVELOPMENT: CLEAR SLIGHTLY CLOUDY
 MOD. TURBID VERY MUDDY

ODOR OF WATER:
 WATER DISCHARGED TO: GROUND SURFACE TANK TRUCK
 STORM SEWERS STORAGE TANK
 DRUMS OTHER

DEPTH TO WATER AFTER DEVELOPMENT: FEET

MATERIALS USED

- 4 SACKS OF MURIECO FILTRATION MEDIA
- NA SACKS OF _____ CEMENT
- NA GALLONS OF GROUT USED
- NA SACKS OF POWDERED BENTONITE
- 75 POUNDS OF BENTONITE PELLETS 1.5 BUCKETS
- 10 FEET OF 2 INCH PVC BLANK CASING 1.5' CUTOFF
- 10 FEET OF 2 INCH PVC SLOTTED SCREEN

_____ YARD³ CEMENT-SAND (REDI-MIX) ORDERED
 _____ YARD³ CEMENT-SAND (REDI-MIX) USED

CONCRETE PUMPER USED? NO YES

NAME _____

WELL COVER USED: LOCKING STEEL COVER
 CHRISTY BOX
 OTHER TEMPORARY WELL

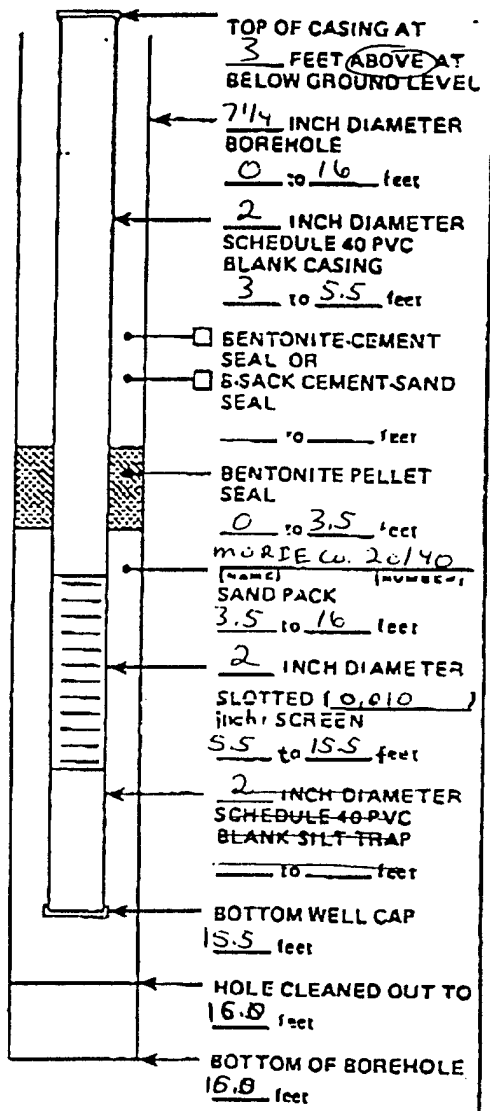
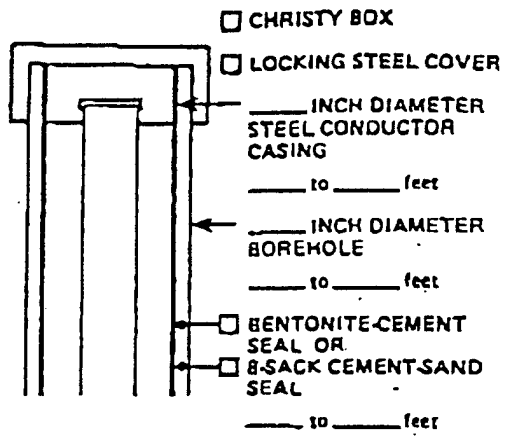

NOT TO SCALE

ADDITIONAL INFORMATION: _____
CALCULATED SAND =
6.25 BAGS



FIELD WELL COMPLETION FORM

JOB NAME: EAKER APB 410 Area

JOB NUMBER: 3K98 **PROPERTY MANAGER:** GNB

ENGINEER: JSB **WRITER:** BFN

WELL NAME: MW1202 **DATE:** 1-7-92

DRILLING COMPANY: AWP OOL

EQUIPMENT: 6 1/4 INCH HOLLOW STEM AUGER **OPERATOR:** V. Sarazza
 INCH ROTARY WASH **REPAIRS (BOULDER):**

GALLONS OF WATER USED DURING DRILLING: NONE **GALLONS**

METHOD OF DEWATERING: Pressure Steam

DEVELOPMENT

METHOD OF DEVELOPMENT:

FIELD	TYPE	FROM	TO	DEVS
	OPEN			
	OPEN			
	OPEN			
	OPEN			

TOTAL WATER REQUIRED DURING DEVELOPMENT: _____ **GALLONS**

CONDITION OF WATER AT END OF DEVELOPMENT:

CLEAR SLIGHTLY CLOUDY

MUD FLUID VERY MUDDY

DEPTH OF WATER:

WATER DISCHARGED TO:

GROUND SURFACE TANK TRUCK

STORM DRENCHERS STORAGE TANK

OTHER OTHER

DEPTH TO WATER AFTER DEVELOPMENT: _____ **FEET**

- MATERIALS USED**
- 2 100# SACKS OF 20/40 COLORADO SILICA SAND
 - _____ SACKS OF _____ CEMENT
 - _____ GALLONS OF GREASE USED
 - 50 SACKS OF FORTIFIED BENTONITE
 - 50 POUNDS OF BENTONITE PELLETS
 - 5 FEET OF 2 INCH PVC BLANK CASING
 - 10 FEET OF 2 INCH PVC SLOTTED SCREEN
 - 2 FEET OF 2 INCH PVC SLOTTED SURFACE
 - _____ YARD³ CEMENT-SAND MEDIUM GRADE
 - _____ YARD³ CEMENT-SAND MEDIUM GRADE

CONCRETE FLESHER USED? YES NO

NAME: _____

WELL COVER USED: LOCKING STEEL COVER CRIBBY BOX OTHER _____

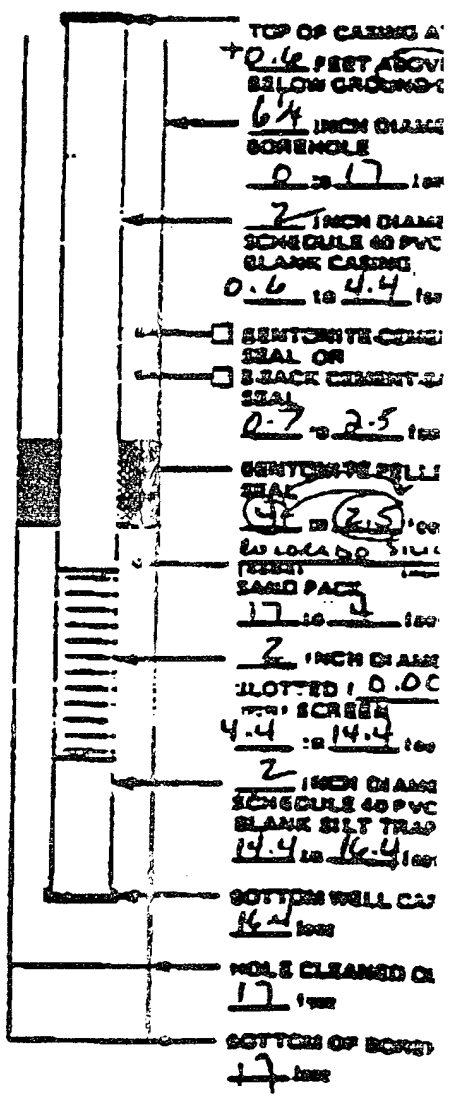
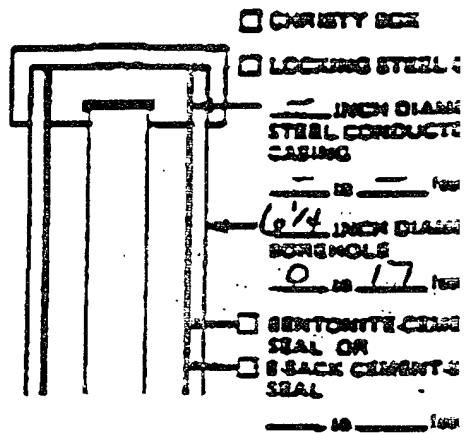

NOT TO SCALE

ADDITIONAL INFORMATION: _____



FIELD WELL COMPLETION FORM

JOB NAME: EAKER AFB

JOB NUMBER: 3K98 **PROJECT MANAGER:** G.V.G.

LOGGED BY: BEN **EDITED BY:**

WELL NAME: MW1203 **DATE:** 1-7-92

DRILLING COMPANY: POOL DRILLING

EQUIPMENT: 6 1/4 INCH HOLLOW STEM AUGER **DRILLER:** V. BARNETT
 INCH ROTARY WASH **WELLS DRILLER:** 043

GALLONS OF WATER USED DURING DRILLING: _____ **GALLONS**

METHOD OF SUBSTANTIATION FOR VS DRILLING: HIGH PRESSURE STEM

DEVELOPMENT

METHOD OF DEVELOPMENT: _____

DEVELOPMENT LOG DATA:

YIELD:	QPM	TIME FROM	TO	DATE:
YIELD:	QPM	TIME FROM	TO	DATE:
YIELD:	QPM	TIME FROM	TO	DATE:
YIELD:	QPM	TIME FROM	TO	DATE:

TOTAL WATER REQUIRED DURING DEVELOPMENT: _____ **GALLONS**

DESCRIPTION OF TURBIDITY AT END OF DEVELOPMENT: CLEAR SLIGHTLY CLOUDY
 MUD TURBID VERY MUDDY

ORDER OF WATER: _____

WATER OBTAINED BY: GROUND SURFACE TANK TRUCK
 STREAM CISTERN STORAGE TANK
 DRUM OTHER

DEPTH TO WATER AFTER DEVELOPMENT: _____ **FEET**

MATERIALS USED

- 2 SACKS OF 20/40 Silica Grade SAND
- _____ SACKS OF _____ CEMENT
- _____ GALLONS OF GROUT USED
- _____ SACKS OF POWDERED BENTONITE
- 50 POUNDS OF BENTONITE PELLETS
- 5 FEET OF 2 INCH PVC BLANK CASING
- 10 FEET OF 2 INCH PVC SLOTTED SCREEN
- 2 " " 2 " " 5/8 " SUMP

_____ YARD³ CEMENT SAND (MICH/MI) ORDERED
 _____ YARD³ CEMENT SAND (MICH/MI) USED

CONCRETE PUMPER USED? NO YES

NAME: _____

WELL COVER USED: LOCKING STEEL COVER
 CHASTY BOX
 OTHER _____

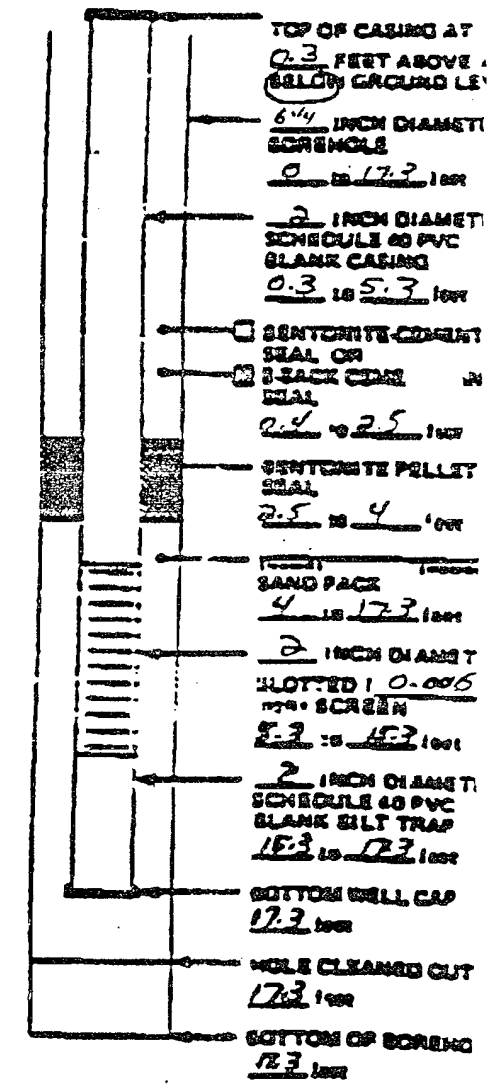
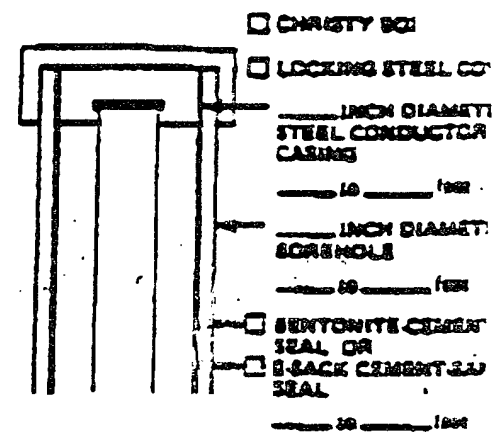

NOT TO SCALE

ADDITIONAL INFORMATION: _____

