

LOAN DOCUMENT

PHOTOGRAPH THIS SHEET

①

DTIC ACCESSION NUMBER

LEVEL

INVENTORY

Site Specific Test Plan for Free

DOCUMENT IDENTIFICATION

14 Oct 90

DISTRIBUTION STATEMENT A
Approved for Public Release
Distribution Unlimited

DISTRIBUTION STATEMENT

ACCESSION FOR	
NTIS	GRAM <input checked="" type="checkbox"/>
DTIC	TRAC <input type="checkbox"/>
UNANNOUNCED	<input type="checkbox"/>
JUSTIFICATION	
BY	
DISTRIBUTION/	
AVAILABILITY CODES	
DISTRIBUTION	AVAILABILITY AND/OR SPECIAL
A-1	

DISTRIBUTION STAMP

DATE ACCESSIONED

DATE RETURNED

REGISTERED OR CERTIFIED NUMBER

20001122 049

DATE RECEIVED IN DTIC

REGISTERED OR CERTIFIED NUMBER

PHOTOGRAPH THIS SHEET AND RETURN TO DTIC-FDAC

H
A
N
D
L
E

W
I
T
H

C
A
R
E

**SITE-SPECIFIC TEST PLAN
FOR FREE-PRODUCT RECOVERY
TESTING AT COLUMBUS
AIR FORCE BASE, MISSISSIPPI**

DRAFT



PREPARED FOR:

**AIR FORCE CENTER FOR ENVIRONMENTAL EXCELLENCE
TECHNOLOGY TRANSFER DIVISION
(AFCEE/ERT)
3207 NORTH ROAD BLDG 532
BROOKS AFB, TEXAS 78235-5357**

AND

COLUMBUS AFB, MISSISSIPPI

OCTOBER 14, 1996

DEFENSE TECHNICAL INFORMATION CENTER REQUEST FOR SCIENTIFIC AND TECHNICAL REPORTS

Title
AFCEE Collection

1. Report Availability (Please check one box)

- This report is available. Complete sections 2a - 2f.
- This report is not available. Complete section 3.

2a. Number of Copies Forwarded

1 each

2b. Forwarding Date

July/2000

2c. Distribution Statement (Please check ONE box)

DoD Directive 5230.24, "Distribution Statements on Technical Documents," 18 Mar 87, contains seven distribution statements, as described briefly below. Technical documents MUST be assigned a distribution statement.

- DISTRIBUTION STATEMENT A: Approved for public release. Distribution is unlimited.
- DISTRIBUTION STATEMENT B: Distribution authorized to U.S. Government Agencies only.
- DISTRIBUTION STATEMENT C: Distribution authorized to U.S. Government Agencies and their contractors.
- DISTRIBUTION STATEMENT D: Distribution authorized to U.S. Department of Defense (DoD) and U.S DoD contractors only.
- DISTRIBUTION STATEMENT E: Distribution authorized to U.S. Department of Defense (DoD) components only.
- DISTRIBUTION STATEMENT F: Further dissemination only as directed by the controlling DoD office indicated below or by higher authority.
- DISTRIBUTION STATEMENT X: Distribution authorized to U.S. Government agencies and private individuals or enterprises eligible to obtain export-controlled technical data in accordance with DoD Directive 5230.25, Withholding of Unclassified Technical Data from Public Disclosure, 6 Nov 84.

2d. Reason For the Above Distribution Statement (in accordance with DoD Directive 5230.24)

2e. Controlling Office

HQ AFCEE

2f. Date of Distribution Statement Determination

15 Nov 2000

3. This report is NOT forwarded for the following reasons. (Please check appropriate box)

- It was previously forwarded to DTIC on (date) and the AD number is
- It will be published at a later date. Enter approximate date if known.
- In accordance with the provisions of DoD Directive 3200.12, the requested document is not supplied because:

Print or Type Name

Laura Peña

Signature

Laura Peña

Telephone

210-536-1431

(For DTIC Use Only)

AQ Number M01-01-0332

**SITE-SPECIFIC TEST PLAN FOR FREE-PRODUCT RECOVERY TESTING
AT COLUMBUS AIR FORCE BASE, MISSISSIPPI
CONTRACT NO. F41624-94-C-8012**

DRAFT

to

**Air Force Center for Environmental Excellence
Technology Transfer Division
(AFCEE/ERT)
3207 North Road
Building 532
Brooks AFB, Texas 78235-5357**

and

Columbus Air Force Base, Mississippi

October 14, 1996

by

**Battelle
505 King Avenue
Columbus, Ohio 43201-2693**

This report is a work prepared for the United States Government by Battelle. In no event shall either the United States Government or Battelle have any responsibility or liability for any consequences of any use, misuse, inability to use, or reliance upon the information contained herein, nor does either warrant or otherwise represent in any way the accuracy, adequacy, efficacy, or applicability of the contents hereof.

TABLE OF CONTENTS

	Page
LIST OF TABLES	iv
LIST OF FIGURES	iv
ACRONYMS AND ABBREVIATIONS	v
1.0 INTRODUCTION	1
2.0 SITE DESCRIPTION	2
3.0 PROJECT ACTIVITIES	6
3.1 Mobilization to the Site	7
3.2 Site Characterization Tests	8
3.2.1 Baildown Tests	8
3.2.2 Monitoring Point Installation	8
3.2.3 Soil Sampling	11
3.3 Free-Product Recovery System Installation and Operation	11
3.3.1 System Setup	11
3.3.2 System Shakedown	14
3.3.3 System Startup and Test Operations	14
3.3.4 Soil-Gas Profile/Oxygen Radius of Influence Test	15
3.3.5 Soil-Gas Permeability Tests	15
3.3.6 LNAPL and Groundwater-Level Monitoring	15
3.3.7 In Situ Respiration Test	15
3.3.8 Extended Testing	16
3.4 Demobilization	16
4.0 BIOSLURPER SYSTEM DISCHARGE	16
4.1 Vapor Discharge Disposition	16
4.2 Aqueous Influent/Effluent Disposition	18
4.3 Free-Product Recovery Disposition	18
5.0 SCHEDULE	18
6.0 PROJECT SUPPORT ROLES	19
6.1 Battelle Activities	19
6.2 Columbus AFB Support Activities	19
6.3 AFCEE Activities	20
7.0 REFERENCE	22
APPENDIX A - FREE-PRODUCT/WATER-LEVEL MEASUREMENTS	
APPENDIX B - WELL DETAILS	
APPENDIX C - GEOLOGICAL CROSS-SECTIONS/SOIL BORING LOGS	

LIST OF TABLES

Table 1. Schedule of Free-Product Recovery Pilot Test Activities	7
Table 2. Benzene and TPH Vapor Discharge Levels at Previous Bioslurper Test Sites	17
Table 3. Air Release Summary Information	17
Table 4. Health and Safety Information Checklist	21

LIST OF FIGURES

Figure 1. Site Location and Vicinity Map	3
Figure 2. Free Product Contour Map	4
Figure 3. Site and Existing Wells	5
Figure 4. General Bioslurper Well and Monitoring Point Arrangement.	9
Figure 5. Schematic Diagram of a Typical Monitoring Point.	10
Figure 6. Free-Product Recovery Process Flow at Columbus AFB, Mississippi.	12
Figure 7. Schematic Diagram of a Typical Free-Product Recovery Well.	13

ACRONYMS AND ABBREVIATIONS

AFB	Air Force Base
AFCEE/ERT	U.S. Air Force Center for Environmental Excellence, Technology Transfer Division
avgas	aviation gasoline
bgs	below ground surface
BTEX	benzene, toluene, ethylbenzene, and xylenes
DRO	diesel-range organics
GRO	gasoline-range organics
JP	jet propulsion (fuel)
LNAPL	light, nonaqueous-phase liquid
POC	Point-of-Contact
SVE	soil vapor extraction
TEPH	total extractable petroleum hydrocarbons
TPH	total petroleum hydrocarbons
TVH	total volatile hydrocarbons
TVPH	total volatile petroleum hydrocarbons
UST	underground storage tank

**SITE-SPECIFIC TEST PLAN FOR FREE-PRODUCT RECOVERY TESTING
AT COLUMBUS AIR FORCE BASE, MISSISSIPPI**

DRAFT

to

**Air Force Center for Environmental Excellence
Technology Transfer Division
(AFCEE/ERT)
Brooks AFB, Texas 78235-5357**

October 14, 1996

1.0 INTRODUCTION

The AFCEE/ERT is conducting a multi-site initiative to develop more effective methods of determining the feasibility of light, nonaqueous-phase liquid (LNAPL) free-product recovery as well as the best method of recovery. The technologies tested in the Bioslurper Initiative are skimming, vacuum-enhanced free-product recovery/bioremediation (bioslurping), and drawdown pumping. The field test and evaluation are intended to demonstrate the initial feasibility of each technology by measuring system performance in the field. System performance parameters, mainly free-product recovery, will be determined at numerous sites. Field testing will be performed at many sites to determine the effects of different organic contaminant types and concentrations and different geological conditions on free-product recovery effectiveness.

Plans for the field test activities are presented in two documents. The first is the overall Test Plan and Technical Protocol for the entire program entitled *Test Plan and Technical Protocol for Bioslurping* (Battelle, 1995). The overall plan is supplemented by plans specific to each test site. The concise site-specific plans effectively communicate planned site activities and operational parameters.

The overall Test Plan and Technical Protocol was developed as a generic plan for the Bioslurper Initiative to improve the accuracy and efficiency of site-specific Test Plan preparation. The field program involves installation and operation of the bioslurping system supported by a wide variety of site characterization, performance monitoring, and chemical analysis activities. The basic methods to be applied from site to site do not change. Preparation and review of the overall Test Plan and Technical Protocol allows efficient documentation and review of the basic approach to the test program. Peer and regulatory review were performed for the overall Test Plan and Technical Protocol to ensure the credibility of the overall program.

This report is the site-specific Test Plan for application of bioslurping at Columbus Air Force Base (AFB), Mississippi. It was prepared based on site-specific information received by Battelle from Columbus AFB and other pertinent information to support the overall Test Plan and Technical Protocol.

Site-specific information for Columbus AFB has identified subsurface hydrocarbon contamination at the aboveground jet fuel tank farm, Spill Site 26 (SS-26). The contamination is generally associated with JP-4 jet fuel. Free-product LNAPL has been measured in thicknesses in excess of 6.5 ft in some areas of the site. Based on free-product thickness measurements taken on April 29, 1996, the most likely well locations for conducting the free-product recovery testing is dual SVE-fuel extraction well R-4 or fuel extraction well F-1. These wells had free-product thicknesses measuring 4.80 ft and 6.58 ft, respectively (CH2M Hill, 1996a). As these are the largest free-product thicknesses recorded at the site, it is likely that these wells will be used for testing. However, if circumstances arise that prevent the use of these wells an alternative well will be selected. A table showing free-product/water-level measurements for all existing wells at SS-26 is shown in Appendix A.

2.0 SITE DESCRIPTION

The following site description of SS-26 is based primarily on two documents prepared by CH2M Hill, Inc, the operator of an existing recovery system presently being used at the site. The first document is the most recent monitoring report for the site, titled *Air Force Installation Restoration Program, 3rd Quarter Monitoring Report, Spill Site 26, Columbus Air Force Base, Mississippi*, dated June 13, 1996; and the second is a technical memorandum titled *SS-26 Revised Operations Approach to Enhance Free Product Recovery, Columbus AFB, Mississippi*, dated July 8, 1996.

Columbus AFB is located in northeastern Mississippi. Spill Site 26 is located on the southern end of the base. A site location and vicinity map is shown in Figure 1.

In July 1995, SS-26 was estimated to have subsurface contamination of approximately 70,000 gallons of free-product (CH2M Hill, 1996b). Figure 2 shows a free product contour map. The plume of contamination is approximately 450 ft (north to south) by 600 ft (east to west).

A remediation system is in place at the site and has been operational since June 1995. The system consists of soil vapor extraction (SVE), air injection, and groundwater and free-phase fuel recovery. Figure 3 shows the site and existing wells. Detail drawings of the various wells used in the

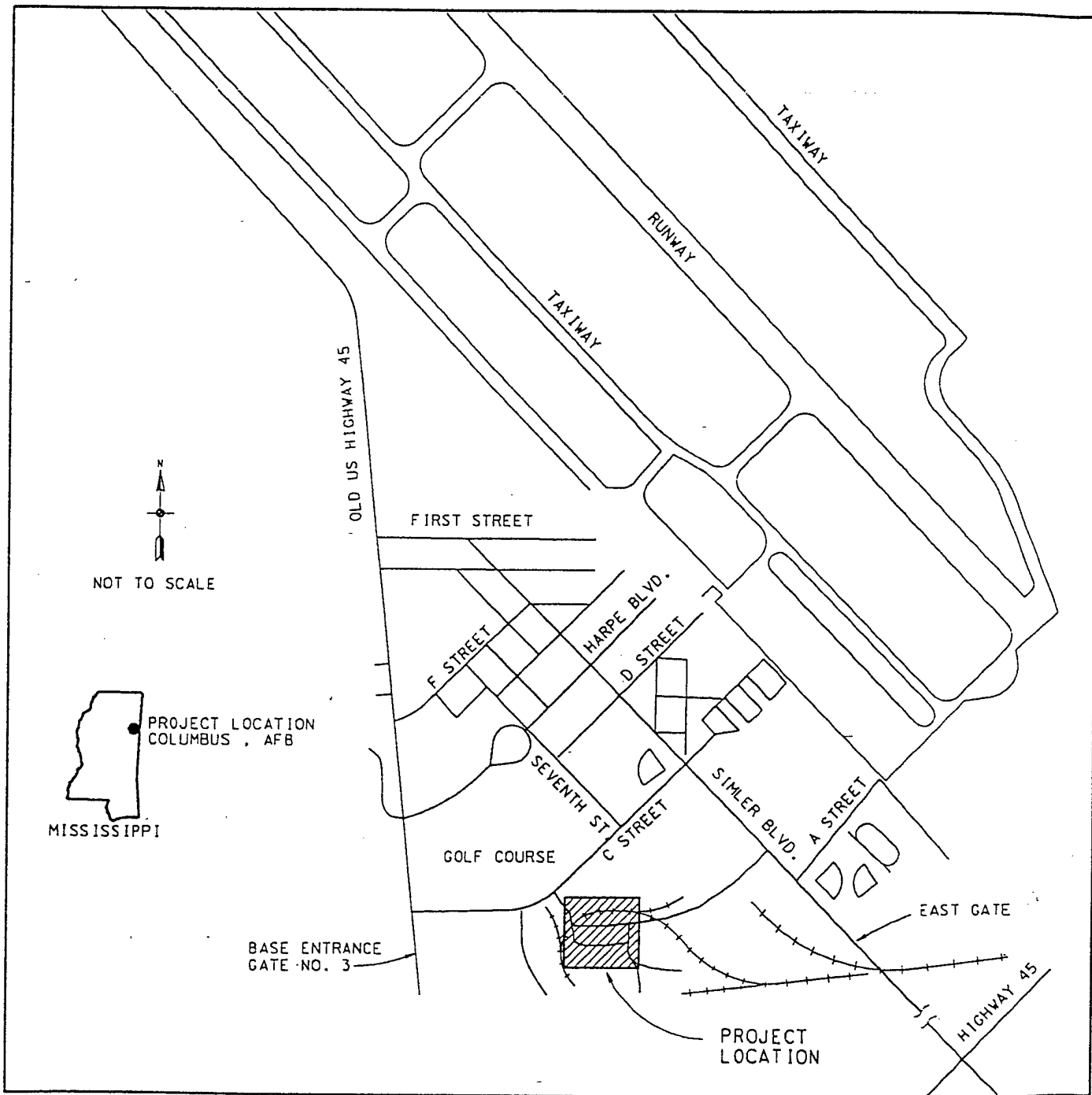

Figure 1. Site Location and Vicinity Map

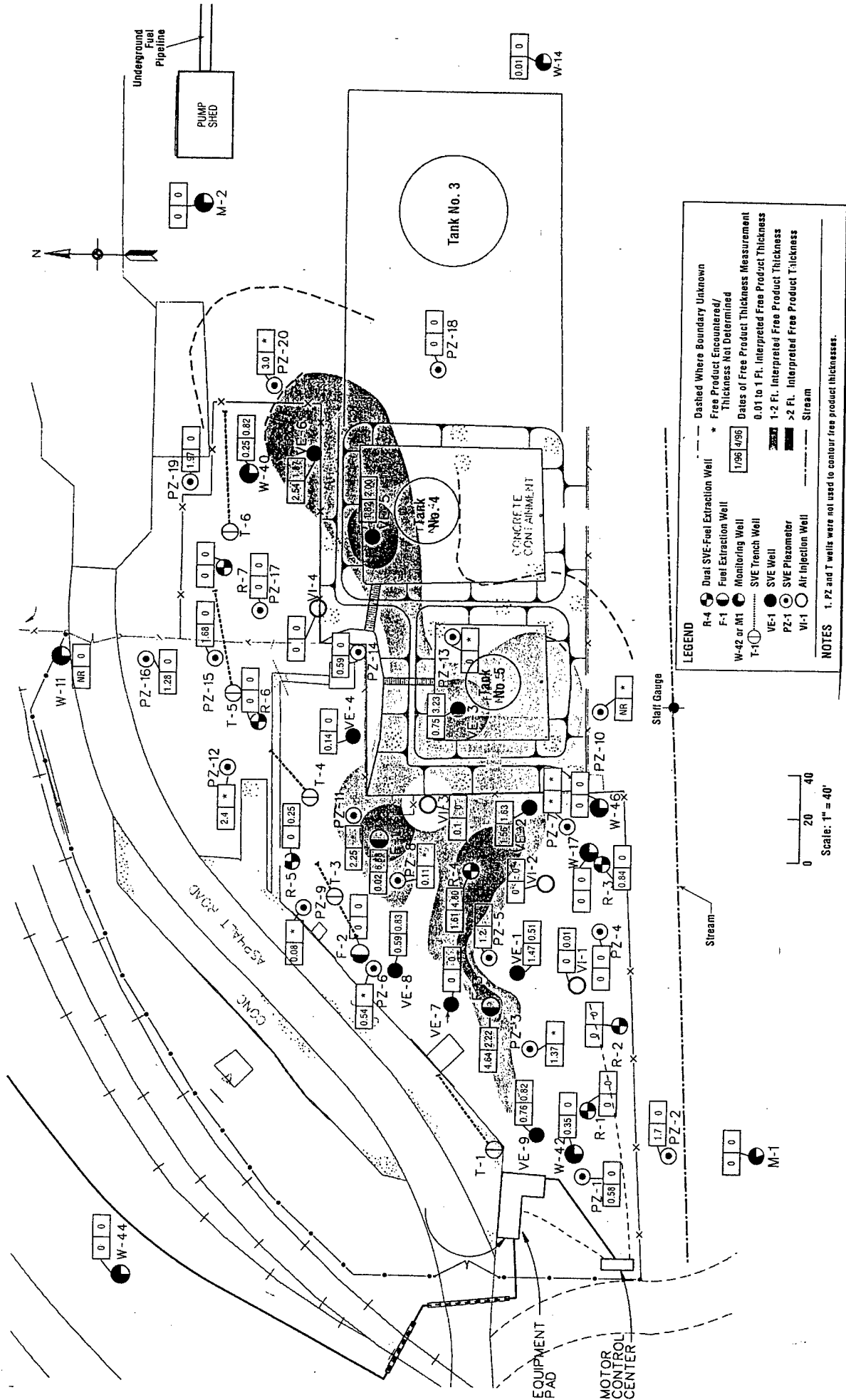

Figure 2. Free Product Contour Map

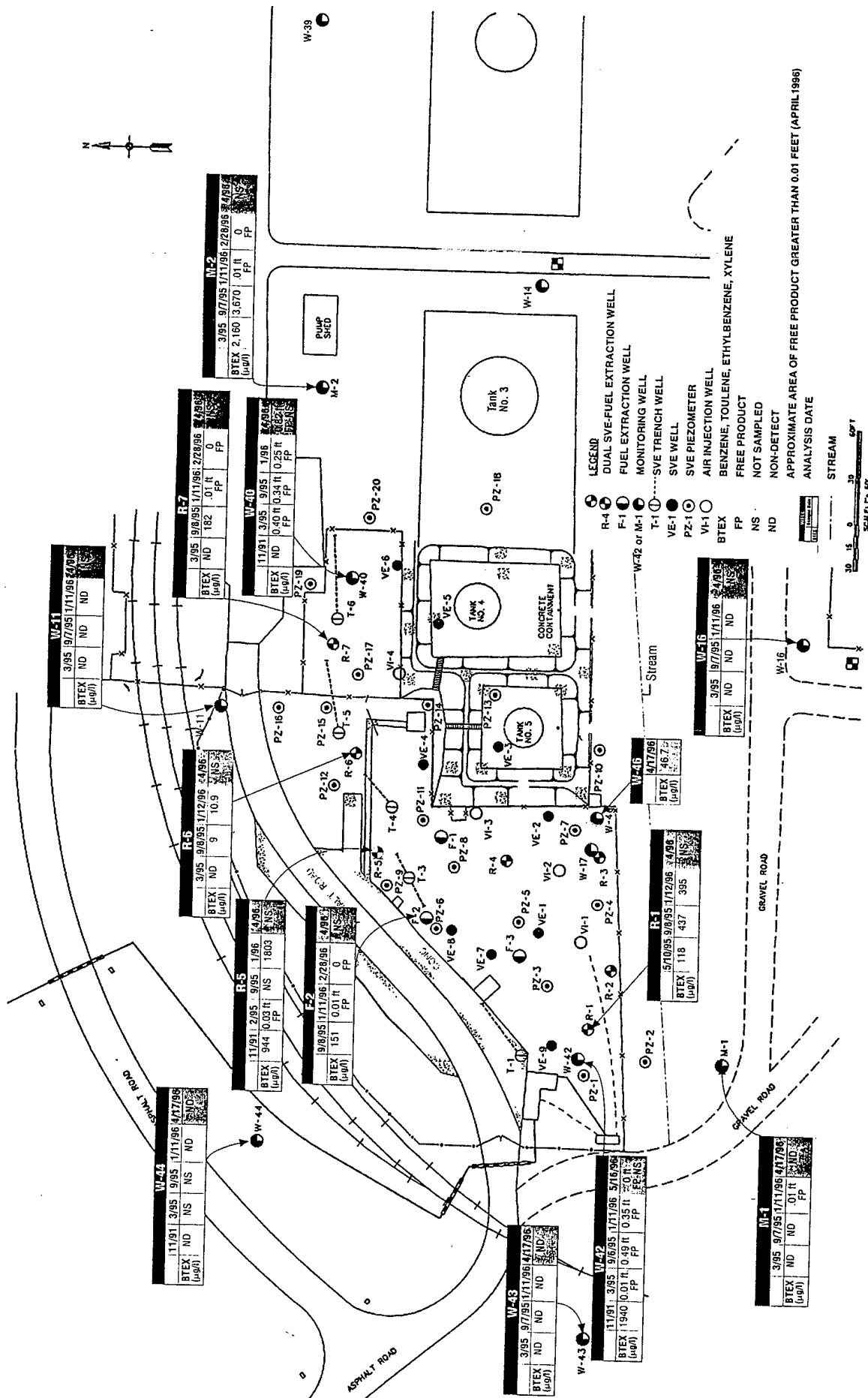

Figure 3. Site and Existing Wells

system are included in Appendix B. Since operation of the system began, approximately 3,100 gallons of fuel have been removed. Of this 3,100 gallons, approximately 1,850 gallons is attributed to free-product recovery and 1,250 gallons to volatilization. The present recovery goal for the site is 40% of the total free product present or 30,000 gallons. Thus it is estimated that the existing system has recovered 10% of the removable product to date (CH2M Hill, 1996a). At various times five to seven recovery wells have been operated in groundwater extraction mode at the site, resulting in a combined total recovery rate of approximately 6 gallons per minute.

The geology of the site includes interbedded sediments ranging in size from clay to gravel. Interbedded layers of sands and silts are present from the ground surface to a depth of approximately 15 ft bgs. A 10-ft-thick layer of gravel lies below the interbedded sand and silt layers. An unconformity is present between the base of the gravel layer and the underlying Eutaw Formation. Geologic cross sections for the site as well as examples of soil boring logs are included in Appendix C. The general direction of groundwater flow in the vicinity of SS-26 is toward the southwest with groundwater discharging into the stream to the south. The depth to groundwater ranges from approximately 6 to 22 ft bgs. Groundwater levels throughout SS-26 have been lowered approximately 5 ft to adequately expose the smear zone.

Groundwater samples were collected on April 17 and 18, 1996 from two downgradient monitoring wells (W-43 and W-44) and one well from the southern boundary of the site (W-46). These samples were analyzed for benzene, toluene, ethylbenzene, and xylenes (BTEX). BTEX compounds were detected in only W-46 at a concentration of 47 $\mu\text{g/L}$ (total BTEX). Both downgradient wells were below quantitative detection limits. As these wells are approximately 120 ft downgradient from SS-26, it would appear that contamination has not migrated significantly downgradient (CH2M Hill, 1996a).

3.0 PROJECT ACTIVITIES

The field activities discussed in the following sections are planned for the free-product recovery pilot test at Columbus AFB. Battelle understands that the existing free-product recovery system operated by CH2M Hill will be shut down prior to and during the duration of the planned pilot test. Additional details about the activities are presented in the overall Test Plan and Technical Protocol (Battelle, 1995). As appropriate, specific sections in the overall Test Plan and Technical Protocol are referenced. Table 1 presents the schedule of activities for the free-product recovery pilot test activities at Columbus AFB.

TABLE 1. SCHEDULE OF FREE-PRODUCT RECOVERY PILOT TEST ACTIVITIES

Pilot Test Activity	Schedule
Mobilization	Days 1-2
Site Characterization LNAPL/Groundwater Interface Monitoring and Baildown Tests Soil-Gas Survey (Limited) Monitoring Point Installation (3 monitoring points) Soil Sampling (BTEX, total petroleum hydrocarbons (TPH), physical characteristics)	Days 2-3
System Installation	Days 2-3
Test Startup	Day 3
Skimmer Pump Test (2 days)	Days 3-4
Bioslurper Pump Test (4 days)	Days 5-8
Soil-Gas Permeability Testing	Day 5
Skimmer Pump Test (continued)	Day 9
In Situ Respiration Test - Air/Helium Injection	Day 9
In Situ Respiration Test - Monitoring	Days 10-13
Drawdown Pump Test (2 days)	Days 10-11
Demobilization/Mobilization	Days 12-13

3.1 Mobilization to the Site

After the site-specific Test Plan is approved, Battelle staff will mobilize equipment to the site. Some of the equipment will be shipped via air express to Columbus AFB prior to staff arrival. The Base Point-of-Contact (POC) will have been asked in advance to find a suitable holding facility to receive the

free-product recovery pilot test equipment so that it will be easily accessible to the Battelle staff when they arrive with the remainder of the equipment. The exact mobilization date will be confirmed with the Base POC as far in advance of fieldwork as is possible. The Battelle POC will provide the Base POC with information on each Battelle employee who will be on site. Battelle personnel will be mobilized to the site after confirmation that the shipped equipment has been received by Columbus AFB.

3.2 Site Characterization Tests

3.2.1 Baildown Tests

The baildown test is the primary test for selection of the bioslurper test well. Baildown tests are also useful for the evaluation of actual versus apparent free-product thicknesses. Baildown tests will be performed at wells that contain measurable thicknesses of LNAPL to estimate the LNAPL recovery potential at those particular wells. In most cases, the well exhibiting the highest rate of LNAPL recovery will be selected for the free-product recovery extraction well. A sample of free LNAPL will be collected at this point for analyses of boiling point distribution and BTEX concentration. Detailed procedures for the baildown tests are provided in Section 5.6 of the overall Test Plan and Technical Protocol (Battelle, 1995).

3.2.2 Monitoring Point Installation

Monitoring points must be installed to determine the radius of influence of the bioslurper system in the vadose zone. A general arrangement of the bioslurping well and monitoring points is shown in Figure 4.

Upon completion of the initial soil-gas survey and baildown tests, at least three soil-gas monitoring points will be installed (unless existing monitoring points are available for use) to measure soil-gas changes that occur during free-product recovery operation. These monitoring points should be located in highly contaminated soils within the free-phase plume and should be positioned to allow detailed monitoring of the in situ changes in soil-gas composition caused by the bioslurper system. A schematic diagram of a typical monitoring point is shown in Figure 5. Information on monitoring point installation can be found in Section 4.2.1 of the overall Test Plan and Technical Protocol (Battelle, 1995).

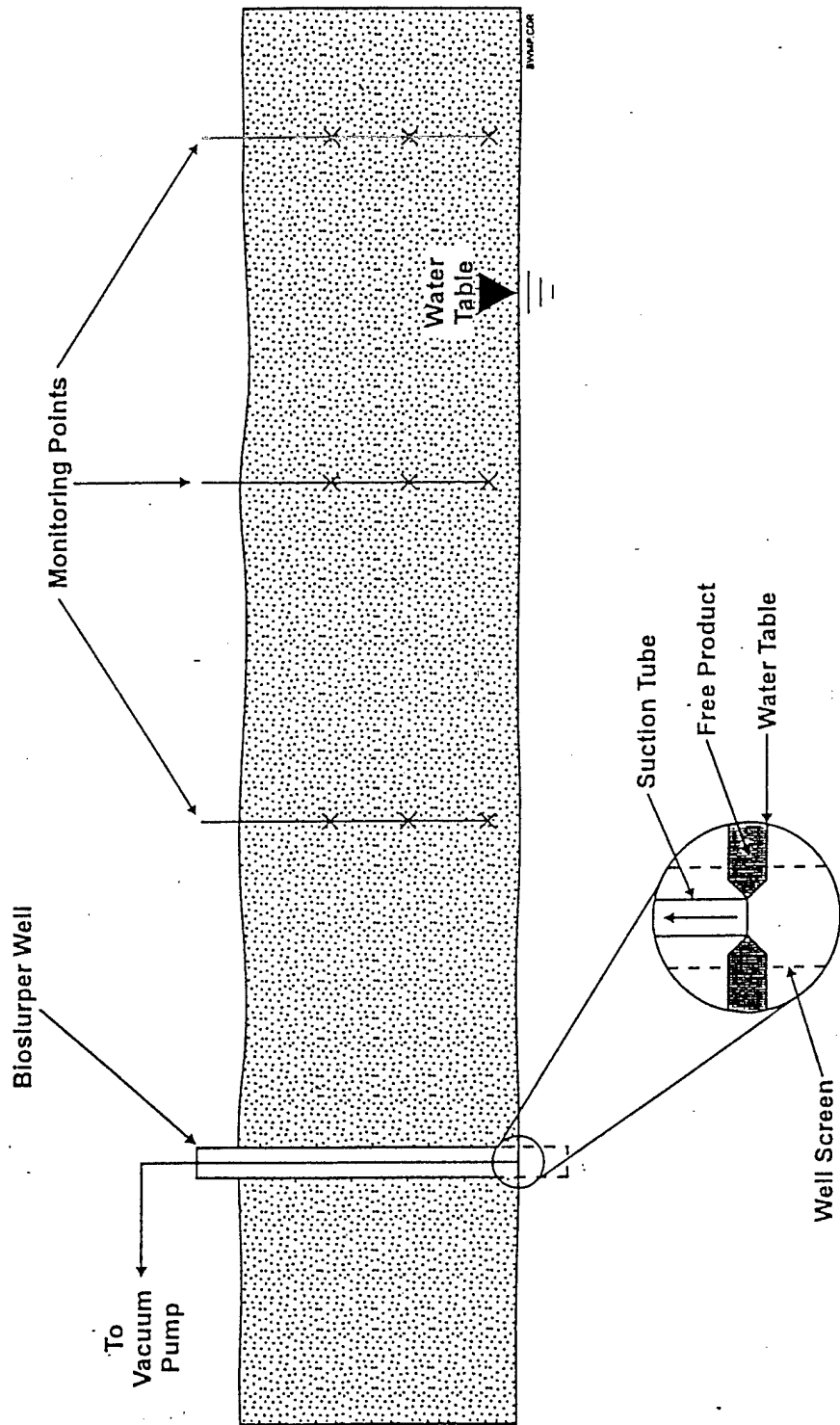

Figure 4. General Bioslurper Well and Monitoring Point Arrangement

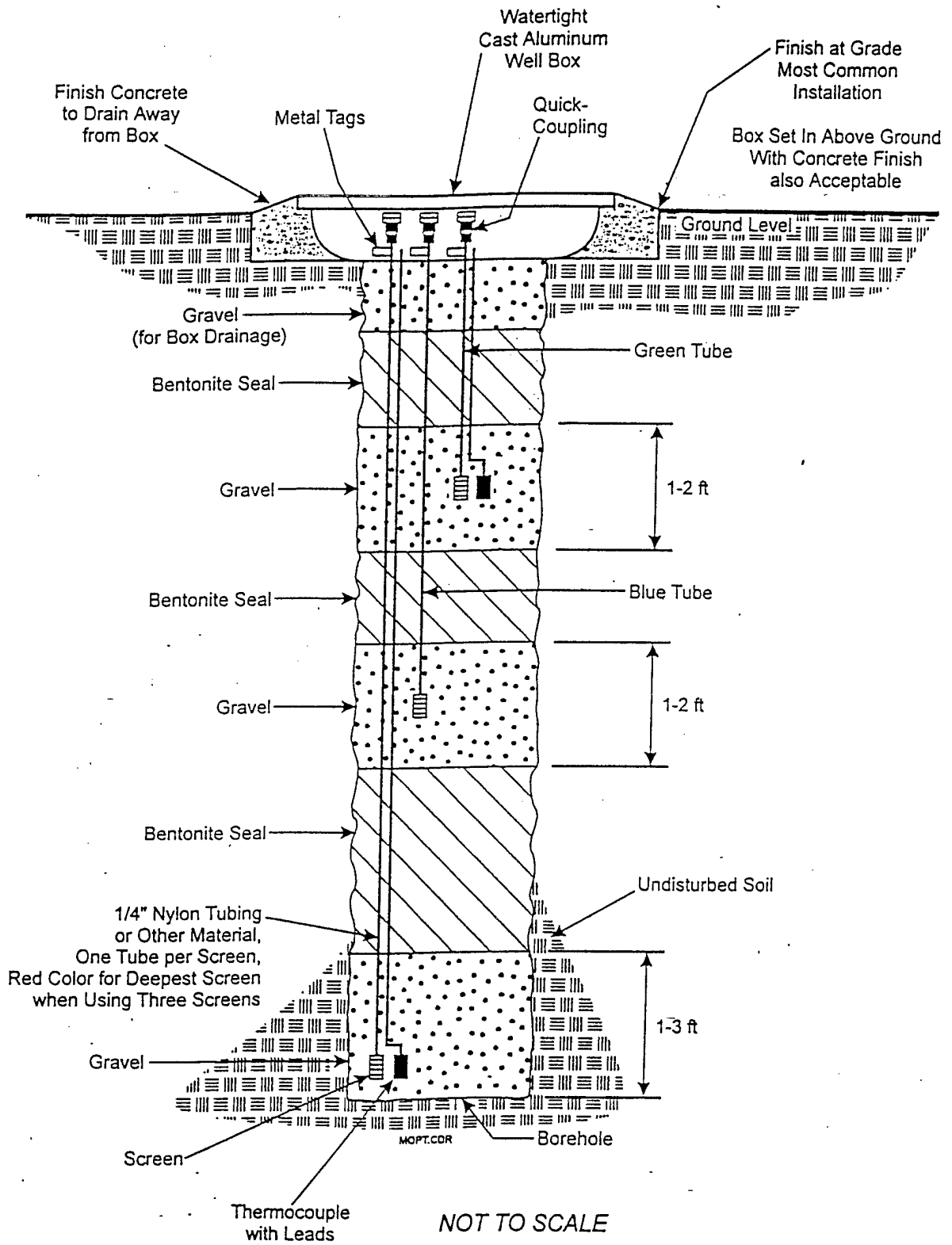

Figure 5. Schematic Diagram of a Typical Monitoring Point

3.2.3 Soil Sampling

Soil samples will be collected from each boring to determine the physical and chemical composition of the soil near the bioslurper test site. Soil samples will be collected from the boreholes advanced for monitoring point installation at two or three locations at the site chosen for the bioslurper test. Generally, samples will be collected from the capillary fringe over the free product.

Soil samples from each boring will be analyzed for BTEX, bulk density, moisture content, particle size distribution, porosity, and total petroleum hydrocarbon (TPH). Section 5.5.1 of the overall Test Plan and Technical Protocol (Battelle, 1995) contains additional information on field measurements and sample collection procedures for soil sampling.

3.3 Free-Product Recovery System Installation and Operation

Once the well to be used for the free-product recovery pilot test installation at Columbus AFB has been identified, the bioslurper pump and support equipment will be installed, and pilot testing will be initiated.

3.3.1 System Setup

After the preliminary site characterization has been completed and the free-product recovery candidate well has been selected, the shipped equipment will be mobilized from the holding facility to the test site, and the bioslurper system will be assembled. Figure 6 shows a flow diagram of the free-product recovery process. Figure 7 illustrates a typical free-product recovery well that will be used at Columbus AFB.

Before the LNAPL recovery tests are initiated, all relevant baseline field data will be collected and recorded. These data will include soil-gas concentrations, initial soil-gas pressures, the depth to groundwater, and the LNAPL thickness. Ambient soil and all atmospheric conditions (e.g., temperature and barometric pressure) also will be recorded. All emergency equipment (i.e., emergency shutoff switches and fire extinguishers) will be installed and checked for proper operation at this time.

A clear, level 20-ft by 10-ft area near the well selected for the free-product recovery pilot test installation will be identified to station the equipment required for bioslurper system operation.

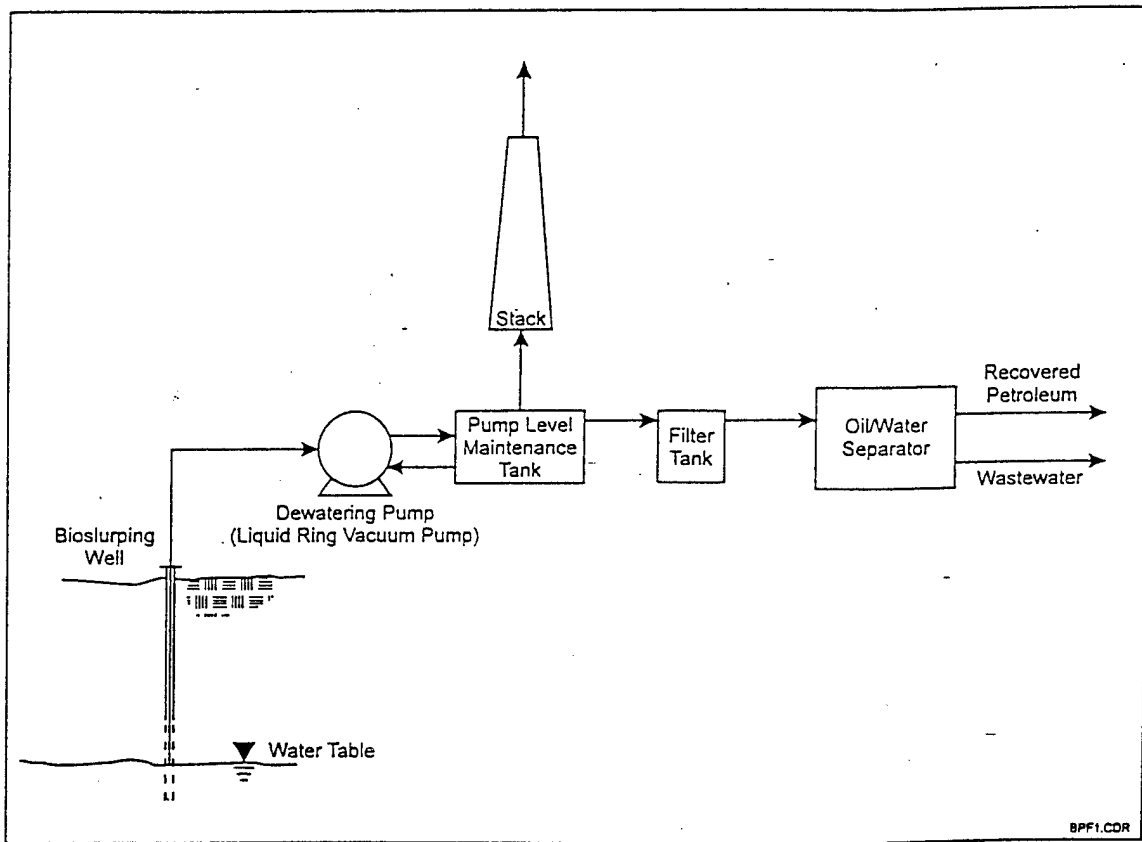

Figure 6. Free-Product Recovery Process Flow Columbus AFB, Mississippi

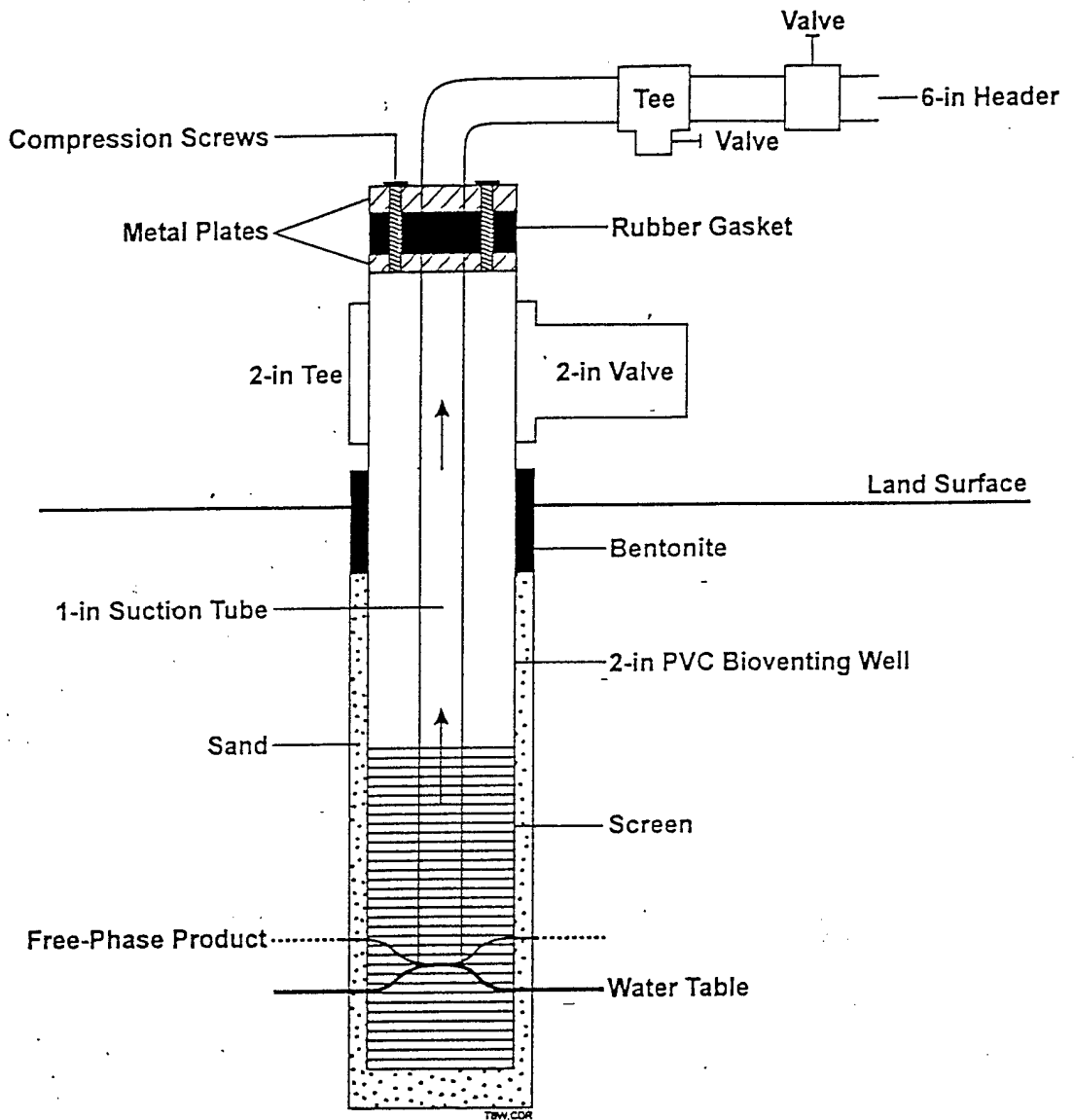

Figure 7. Schematic Diagram of a Typical Free-Product Recovery Well

Additional information on bioslurper system installation is provided in Section 6.0 of the overall Test Plan and Technical Protocol (Battelle, 1995).

3.3.2 System Shakedown

A brief startup test will be conducted to ensure that the system is constructed properly and operates safely. All system components will be checked for problems and/or malfunctions. A checklist will be provided to document the system shakedown.

3.3.3 System Startup and Test Operations

After installation is complete and the bioslurper system is confirmed to be operating properly, the LNAPL recovery tests will be started. The Bioslurper Initiative has been designed to evaluate the effectiveness of bioslurping as an LNAPL recovery test technology relative to conventional gravity-driven LNAPL recovery technologies. The Bioslurper Initiative includes three separate LNAPL recovery tests: (1) a skimmer pump test, (2) a bioslurper pump test, and (3) a drawdown pump test. The three recovery tests are described in detail in Section 7.3 of the overall Test Plan and Technical Protocol (Battelle, 1995).

The bioslurper system operating parameters that will be measured during operation are vapor discharge composition, aqueous effluent contaminant concentration, LNAPL recovery volume rates, vapor discharge volume rates, and groundwater discharge volume rates. Vapor monitoring will consist of periodic monitoring of TPH using hand-held instruments supplemented by two samples collected for detailed laboratory analysis. Two samples of aqueous effluent will be collected for analysis of BTEX and TPH. Recovered LNAPL volume will be recorded using an in-line flow-totalizing meter. The off-gas discharge volume will be measured using a calibrated pitot tube, and the groundwater discharge volume will be recorded using an in-line flow-totalizing meter. Section 8.0 of the overall Test Plan and Technical Protocol (Battelle, 1995) describes process monitoring of the bioslurper system.

3.3.4 Soil-Gas Profile/Oxygen Radius of Influence Test

Changes in soil-gas profiles will be measured before and during the bioslurper pump test. Soil gas will be monitored for concentrations of oxygen, carbon dioxide, and TPH using field instruments. These measurements will be used to determine the oxygen radius of influence of the bioslurper system.

3.3.5 Soil-Gas Permeability Tests

A soil-gas permeability test will be conducted concurrently with startup of the bioslurper pump test. Soil-gas permeability data will support the process of estimating the vadose zone radius of influence of the bioslurper system. Soil-gas permeability results also will aid in determining the number of wells required if it is decided to treat the site with a full-scale bioslurper system. The soil-gas permeability test method is described in Section 5.7 of the overall Test Plan and Technical Protocol (Battelle, 1995).

3.3.6 LNAPL and Groundwater-Level Monitoring

During the bioslurper pump test, the levels of both LNAPL and groundwater will be monitored in a well adjacent to the extraction well if such a well exists. The top of the monitoring well will be sealed from the atmosphere so the subsurface vacuum will be contained. Additional information for the monitoring of fluid levels is provided in Section 4.3.4 of the overall Test Plan and Technical Protocol (Battelle, 1995).

3.3.7 In Situ Respiration Test

An in situ respiration test will be conducted after completion of the free-product recovery pilot test. The in situ respiration test will involve injection of air and helium into selected soil-gas monitoring points followed by monitoring changes in concentrations of oxygen, carbon dioxide, TPH, and helium in soil gas at the injection point. Measurement of the soil-gas composition typically will be conducted at 2, 4, 6, and 8 hours and then every 4 to 12 hours for about 2 days. The timing of the tests will be adjusted based on the oxygen-use rate. If oxygen depletion occurs rapidly, more frequent monitoring will be required. If oxygen depletion is slow, less frequent readings will be acceptable. The oxygen utilization

rate will be used to estimate the biodegradation rate at the site. Further information on the procedures and data collection of the in situ respiration test is provided in Section 5.8 of the overall Test Plan and Technical Protocol (Battelle, 1995).

3.3.8 Extended Testing

The Air Force has the option of extending the operation of the bioslurper system for up to 6 months if LNAPL recovery rates are promising. If extended testing is to be performed, the Air Force will need to provide electrical power for long-term operation of the bioslurper pump. Disposition of all generated wastes and routine operation and maintenance of the system will be the Air Force's responsibility. Battelle will provide technical support during the extended testing operation.

3.4 Demobilization

Once all necessary tests have been completed at the Columbus AFB site, the equipment will be disassembled by Battelle staff. The equipment then will be moved back to the holding facility, where it will remain until its next destination is determined. Battelle staff will receive this information and will be responsible for shipment of the equipment to the next site before leaving Columbus AFB.

4.0 BIOSLURPER SYSTEM DISCHARGE

4.1 Vapor Discharge Disposition

Battelle understands that the operation of the free-product recovery test system at Columbus AFB will not require a waiver or a point source air release registration and may require some additional permits. It can be estimated that approximately 60 lb/day of TPH will be released to the atmosphere, while <1.0 lb/day of benzene will be released without treatment. These values are based on the average discharge rates at three bioslurper test sites (Warner Robins AFB, Travis AFB, and Wright-Patterson AFB) that are contaminated with a similar type of fuel. The discharge value may vary depending on concentrations in soil gas and the permeability of the soil. The data for benzene and TPH discharge levels for eight previous bioslurper test sites are presented in Table 2.

TABLE 2. BENZENE AND TPH VAPOR DISCHARGE LEVELS AT PREVIOUS BIOSLURPER TEST SITES

Site Location	Fuel Type	Extraction Rate (scfm)	Benzene (ppmv)	TPH (ppmv)	Benzene Discharge (lb/day)	TPH Discharge (lb/day)
Andrews AFB	No. 2 Fuel Oil	8.0	16	2,000	0.0010	0.20
Bolling AFB, Site 1	No. 2 Fuel Oil	4.0	0.20	153	0.00030	0.0090
Bolling AFB, Site 2	Gasoline	21	370	70,000	2.3	470
Johnston Atoll	JP-5 Jet Fuel	10	0.60	975	0.0017	5.7
Warner Robins AFB, UST 70/72	JP-4 Jet Fuel	5	515	37,000	0.74	110
Warner Robins AFB, SS010	JP-4 Jet Fuel	5.5	13	680	0.021	2.2
Travis AFB	JP-4 Jet Fuel	20	100	10,800	0.58	130
Wright-Patterson AFB	JP-4 Jet Fuel	3.0	ND	595	0	1.0

ND = Not detected.

To ensure the safety and regulatory compliance of the bioslurper system, field soil-gas screening instruments will be used to monitor vapor discharge concentration. The volume of vapor discharge will be monitored daily using air flow instruments. If state regulatory requirements will not permit the expected amount of organic vapor discharge to the atmosphere, the Base POC should inform AFCEE and Battelle so that alternative plans can be made prior to mobilization to the site. Table 3 presents information typically required to complete an air release registration form.

TABLE 3. AIR RELEASE SUMMARY INFORMATION

Data Item	Air Release Information
Contractor Point-of-Contact	Jeff Kittel, (614) 424-6122
Contractor address	Battelle, 505 King Avenue, Columbus, OH 43201
Estimated total quantity of petroleum product to be recovered	To be determined
Description of petroleum product to be recovered	JP-4 jet fuel
Planned date of test start	To be determined
Test duration	9-10 days (active pumping)
Maximum expected volatile organic compound level in air	~60 lb/day TPH, <1.0 lb/day benzene
Stack height above ground level	10 ft

4.2 Aqueous Influent/Effluent Disposition

The flowrate of groundwater pumped by the bioslurper will be less than 10 gpm. However, it may be necessary in Mississippi to obtain a groundwater pumping waiver or registration permit. If one is required, the Base POC will inform Battelle of the necessary steps in obtaining the waiver or permit. The intention of Battelle staff will be to dispose of the wastewater by discharge directly to the oil/water separator of the existing system.

4.3 Free-Product Recovery Disposition

The bioslurper system will recover free-phase product from the pilot tests performed at Columbus AFB. Recovered free product will be turned over to the Base for disposal and/or recycling. The volume of free product recovered from the Base will not be known until the tests have been performed. The maximum recovery rate for this system is 10 gpm, but the actual rate of LNAPL recovery likely will be much lower.

5.0 SCHEDULE

The schedule for the bioslurper fieldwork at Columbus AFB will depend on approval of the project Test Plan. Battelle will determine a definitive schedule as soon as possible after approval is received. Battelle will have two to three staff members on site for approximately 2 weeks to conduct all necessary pilot testing. At the conclusion of the field testing at Columbus AFB, all staff will return their Base passes. Battelle staff will remove all bioslurper field testing equipment from the Base before they leave the site.

6.0 PROJECT SUPPORT ROLES

This section outlines some of the major functions of personnel from Battelle, Columbus AFB, and AFCEE during the free-product recovery pilot test.

6.2 Columbus AFB Support Activities

To support the necessary field tests at Columbus AFB, the Base must be able to provide the following:

- a. Any digging permits and utility clearances that need to be obtained prior to the installation of the soil-gas monitoring points. Any underground utilities should be clearly marked to reduce the chance of utility damage and/or personal injury during soil-gas probe and possible well installation. Battelle will not begin field operations without these clearances and permits.
- b. The Air Force will be responsible for obtaining Base and site clearance for the Battelle staff that will be working at the Base. The Base POC will be furnished with all necessary information on each staff member at least 1 week prior to field startup.
- c. Access to the water treatment facility for the current system will need to be furnished so that Battelle staff can discharge the bioslurper aqueous effluent directly to the oil water separator at the facility.
- d. Regulatory approval, if required, must be obtained by the Base POC prior to startup of the bioslurper pilot test. As stated previously, it is understood that a waiver or permit to allow air releases or a point source air release registration will not be required for emissions of approximately 60 lb/day of TPH and <1.0 lb/day benzene without treatment. A waiver for pumping and discharging groundwater at a rate of 10 gpm may be required. The Base POC will obtain all necessary Base permits prior to mobilization to the site. Battelle will provide technical assistance in preparing regulatory approval documents.
- e. The Base also will be responsible for the disposition of all waste generated from the pilot testing. Such waste includes any soil cuttings generated from drilling, and all aqueous wastestreams produced from the free-product recovery tests. All free product recovered will be disposed of or recycled by the Base.
- f. Before field activities begin, the Health and Safety Plan will be finalized with information provided by the Base POC. Table 4 is a checklist for the information required to complete the

- e. The Base also will be responsible for the disposition of all waste generated from the pilot testing. Such waste includes any soil cuttings generated from drilling, and all aqueous wastestreams produced from the free-product recovery tests. All free product recovered will be disposed of or recycled by the Base.
- f. Before field activities begin, the Health and Safety Plan will be finalized with information provided by the Base POC. Table 4 is a checklist for the information required to complete the Health and Safety Plan. All emergency information will be obtained by the Site Health and Safety officer before operations begin.
- g. Battelle understands that the existing free-product recovery system operated by CH2M Hill will be shut down prior to and during the planned pilot test.

6.3 AFCEE Activities

The AFCEE POC will act as a liaison between Battelle and Columbus AFB staff. The AFCEE POC will ensure that all necessary permits are obtained and the space required to house the bioslurper field equipment is found.

Table 4. Health and Safety Information Checklist

Emergency Contacts	Name	Telephone Number
Hospital	_____	_____
Fire Department	Emergency Switchboard	911
Ambulance and Paramedics	Emergency Switchboard	911
Police Department	Emergency Switchboard	911
EPA Emergency Response Team	Switchboard	(800) 424-8802
Program Contacts		
Air Force	Patrick Haas	(210) 536-4314
Battelle	Jeff Kittel	(614) 424-6122
Columbus AFB	_____	_____
Other	_____	_____
Emergency Routes		
Hospital	_____	
Other	_____	

APPENDIX A

Free-Product/Water-Level Measurements

Table A-3
Free Product / Water Level Measurements
CAFB SS-26

Well ID and Elevation (ft) (BTOC)	Date:	Free Product Depth (ft) (BTOC)	Water Depth (ft) (BTOC)	Free Product Elevation (ft) (BTOC)	Groundwater Elevation (ft) (BTOC) (MSL)	² Corrected Groundwater Elevation (ft)	Free Product Thickness (ft)
R-1 201.81	6/14/93	ND	10.56	ND	191.25	191.25	0
	2/18/95	ND	11.30	ND	190.51	190.51	0
	9/8/95	ND	12.32	ND	189.49	189.49	0
	10/24/95	ND	12.38	ND	189.43	189.43	0
	1/11/96	ND	11.55	ND	190.26	190.26	0
	4/29/96	ND	17.91	ND	183.90	183.90	0
	5/16/96	ND	18.04	ND	183.77	183.77	0
R-2 207.00	6/14/93	15.99	16.33	191.01	190.67	190.93	0.34
	2/15/95	16.50	16.65	190.5	190.35	190.46	0.15
	9/8/95	NM	NM	NM	NM	NM	NM
	10/24/95	ND	17.48	ND	189.52	189.52	0
	1/11/96	ND	16.66	ND	190.34	190.34	0
	4/29/96	ND	21.69	ND	185.31	185.31	0
	5/16/96	ND	21.92	ND	185.08	185.08	0
R-3 210.33	6/14/93	16.74	18.77	193.59	191.56	193.11	2.03
	2/15/95	19.25	21.63	191.08	188.7	190.52	2.38
	9/8/95	NM	NM	NM	NM	NM	NM
	10/24/95	20.51	20.84	189.82	189.49	189.74	0.33
	1/11/96	19.94	20.78	190.39	189.55	190.19	0.84
	4/29/96	ND	24.42	ND	185.91	185.91	0
	5/16/96	ND	23.77	ND	186.56	186.56	0
R-4 207.65	6/14/93	16.68	19.04	190.97	188.61	190.41	2.36
	2/15/95	16.43	18.21	191.22	189.44	190.80	1.78
	9/8/95	NM	NM	NM	NM	NM	NM
	10/24/95	17.32	NM	190.33	NM	NM	*
	1/11/96	17.01	18.62	190.64	189.03	190.26	1.61
	4/29/96	18.28	23.08	189.37	184.57	188.23	4.80
	5/16/96	ND	23.46	ND	184.19	184.19	0
R-5 202.4	6/14/93	12.50	13.64	189.90	188.76	189.63	1.14
	2/15/95	11.15	11.18	191.25	191.22	191.24	0.03
	9/8/95	NM	NM	NM	NM	NM	NM
	10/24/95	12.58	13.48	189.82	188.92	189.61	0.90
	1/11/96	ND	12.38	ND	190.02	190.02	0
	4/29/96	13.45	13.70	188.95	188.70	188.89	0.25
	5/16/96	13.58	13.81	188.82	188.59	188.77	0.23
R-6 202.16	6/14/93	ND	11.24	ND	190.92	190.92	0
	2/15/95	ND	10.84	ND	191.32	191.32	0
	9/8/95	ND	19.49	ND	182.67	182.67	0
	10/24/95	12.31	12.32	189.85	189.84	189.85	0.01
	1/11/96	ND	12.87	ND	189.29	189.29	0
	4/29/96	ND	11.96	ND	190.20	190.20	0
	5/16/96	ND	12.21	ND	189.95	189.95	0

Table A-3
Free Product / Water Level Measurements
CAFB SS-26

Well ID and Elevation (ft) (BTOC)	Date:	Free Product Depth (ft) (BTOC)	Water Depth (ft) (BTOC)	Free Product Elevation (ft) (BTOC)	Groundwater Elevation (ft) (BTOC) (MSL)	² Corrected Groundwater Elevation (ft)	Free Product Thickness (ft)
R-7 201.41	6/14/93	ND	12.02	ND	189.39	189.39	0
	2/15/95	ND	9.24	ND	192.17	192.17	0
	9/8/95	ND	17.56	ND	183.85	183.85	0
	10/24/95	ND	11.03	ND	190.38	190.38	0
	1/11/96	11.11	11.12	190.30	190.29	190.30	0.01
	2/28/96	ND	14.19	ND	187.22	187.22	0
	4/29/96	ND	9.48	ND	191.93	191.93	0
	5/16/96	ND	9.58	ND	191.83	191.83	0
F-1 202.41	6/14/93	10.94	12.94	191.47	189.47	191.00	2.00
	2/15/95	11.17	12.50	191.24	189.91	190.92	1.33
	6/26/95	15.05	16.00	187.36	186.41	187.13	0.95
	7/28/95	13.73	19.18	188.68	183.23	187.39	5.45
	9/8/95	12.18	17.13	190.23	185.28	189.06	4.95
	10/24/95	12.17	14.69	190.24	187.72	189.64	2.52
	1/11/96	12.29	12.31	190.12	190.10	190.12	0.02
	4/17/96	12.92	19.50	189.49	182.91	187.93	6.58
5/16/96	ND	16.32	ND	186.09	186.09	0	
F-2 201.73	6/14/93	11.05	11.06	190.68	190.67	190.68	0.01
	2/15/95	10.55	10.78	191.18	190.95	191.13	0.23
	6/26/95	14.01	14.02	187.72	187.71	187.72	0.01
	7/31/95	11.80	11.83	189.93	189.9	189.92	0.03
	9/8/95	ND	12.45	ND	189.28	189.28	0
	10/24/95	ND	12.30	ND	189.43	189.43	0
	1/11/96	11.39	11.40	190.34	190.33	190.34	0.01
	2/28/96	ND	11.92	ND	189.81	189.81	0
	4/17/96	ND	12.85	ND	188.88	188.88	0
5/16/96	ND	12.85	ND	188.88	188.88	0	
F-3 206.62	6/14/93	11.00	12.15	195.62	194.47	195.35	1.15
	2/15/95	11.53	12.81	195.09	193.81	194.79	1.28
	6/26/95	ND	15.15	ND	191.47	191.47	0
	7/28/95	13.9	16	192.72	191.02	192.32	1.70
	9/8/95	12.68	16.19	193.94	190.43	193.11	3.51
	10/24/95	12.74	13.95	193.88	192.67	193.59	1.21
	1/11/96	11.24	15.88	195.38	190.74	194.28	4.64
	4/17/96	14.45	16.67	192.17	189.95	191.64	2.22
	5/16/96	14.75	16.98	191.87	189.64	191.34	2.23
M-1 204.14	6/14/93	ND	14.18	ND	189.96	189.96	0
	2/15/95	ND	18.95	ND	185.19	185.19	0
	9/8/95	ND	14.87	ND	189.27	189.27	0
	1/11/96	13.54	13.55	190.60	190.59	190.60	0.01
	2/28/96	14.18	14.19	189.96	189.95	189.96	0.01
	4/17/96	ND	14.44	ND	189.70	189.70	0
	5/16/96	ND	14.78	ND	189.36	189.36	0

Table A-3
Free Product / Water Level Measurements
CAFB SS-26

Well ID and Elevation (ft) (BTOC)	Date:	Free Product Depth (ft) (BTOC)	Water Depth (ft) (BTOC)	Free Product Elevation (ft) (BTOC)	Groundwater Elevation (ft) (BTOC) (MSL)	¹ Corrected Groundwater Elevation (ft)	Free Product Thickness (ft)
M-2 202.34	6/14/93	ND	9.01	ND	193.33	193.33	0
	2/15/95	ND	10.31	ND	192.03	192.03	0
	6/26/95	ND	10.73	ND	191.61	191.61	0
	8/1/95	NM	10.56	NM	191.78	191.78	NM
	9/8/95	ND	11.10	ND	191.24	191.24	0
	10/24/95	11.06	11.07	191.28	191.27	191.28	0.01
	1/11/96	10.01	10.02	192.33	192.32	192.33	0.01
	2/28/96	ND	10.57	ND	191.77	191.77	0
	4/17/96	ND	10.41	ND	191.93	191.93	0
5/17/96	ND	10.48	ND	191.86	191.86	0	
PZ-1 198.9	6/14/93	ND	10.41	ND	188.49	188.49	0
	2/15/95	ND	9.87	ND	189.03	189.03	0
	6/23/95	14.38	15.15	184.52	183.75	184.34	0.77
	7/31/95	9.18	>12	189.72	<186.9	<186.9	NM
	9/6/95	8.56	>12	190.34	<186.9	<186.9	NM
	10/24/95	9.4	ND	189.50	ND	ND	*
	1/11/96	8.96	9.54	189.94	189.36	189.80	0.58
	4/17/96	ND	9.3	ND	189.60	189.60	0
	5/16/96	10.27	11.24	-	*	-	*
PZ-2 200.46	6/14/93	ND	10.64	ND	189.82	189.82	0
	2/15/95	ND	10.40	ND	190.06	190.06	0
	6/23/95	11.33	11.34	189.13	189.12	189.13	0.01
	7/31/95	10.94	11.32	189.52	189.14	189.43	0.38
	9/6/95	11.08	11.56	189.38	188.90	189.27	0.48
	10/24/95	11.2	12.49	189.26	187.97	188.95	1.29
	1/11/96	10.28	11.98	190.18	188.48	189.78	1.70
	4/17/96	ND	10.75	ND	189.71	189.71	0
	5/16/96	ND	11.42	ND	189.04	ND	0
PZ-3 201.98	6/14/93	ND	11.52	ND	190.46	190.46	0
	6/23/95	0	0	201.98	201.98	201.98	0
	7/31/95	12.87	12.95	189.11	189.03	189.09	0.08
	9/6/95	13.3	15.32	188.68	186.66	188.20	2.02
	10/24/95	12.75	12.76	189.23	189.22	189.23	0.01
	1/11/96	11.97	13.34	190.01	188.64	189.69	1.37
	4/17/96	12.59	12.62	-	*	-	*
	5/16/96	13.95	14.79	-	*	-	*
PZ-4 209.59	6/14/93	ND	21.16	ND	188.43	188.43	0
	2/15/95	ND	9.93	ND	199.66	199.66	0
	6/23/95	21.22	21.24	188.37	188.35	188.37	0.02
	7/31/95	NM	20.75	NM	188.84	188.84	NM
	9/6/95	21.41	22.92	188.18	186.67	187.82	1.51
	10/24/95	19.91	19.98	189.68	189.61	189.66	0.07
	1/11/96	ND	20.00	ND	189.59	189.59	0
	4/17/96	ND	20.90	ND	188.69	188.69	0
5/16/96	ND	21.67	ND	187.92	187.92	0	

Table A-3
Free Product / Water Level Measurements
CAFB SS-26

Well ID and Elevation (ft) (BTOC)	Date:	Free Product Depth (ft) (BTOC)	Water Depth (ft) (BTOC)	Free Product Elevation (ft) (BTOC)	Groundwater Elevation (ft) (BTOC) (MSL)	¹ Corrected Groundwater Elevation (ft)	Free Product Thickness (ft)
PZ-5 206.2	6/14/93	ND	15.53	ND	190.67	190.67	0
	6/23/95	ND	ND	ND	ND	ND	0
	7/31/95	17.96	18.31	188.24	187.89	188.16	0.35
	9/6/95	18.14	18.62	188.06	187.58	187.95	0.48
	10/24/95	16.69	18.23	189.51	187.97	189.15	1.54
	1/11/96	16.41	17.61	189.79	188.59	189.51	1.20
	4/17/96	17.62	-	-	*	-	*
	5/16/96	Note 1	18.57	Note 1	187.63	187.63	Note 1
PZ-6 201.03	6/14/93	ND	10.03	ND	191.00	191.00	0
	2/15/95	ND	9.94	ND	191.09	191.09	0
	6/23/95	ND	13.03	ND	188.00	188.00	0
	7/31/95	NM	11.31	NM	189.72	189.72	NM
	9/6/95	12.13	12.15	188.90	188.88	188.90	0.02
	10/24/95	11.79	ND	189.24	ND	ND	*
	1/11/96	10.39	10.93	190.64	190.1	190.51	0.54
	4/17/96	11.34	-	-	*	-	*
5/16/96	ND	12.93	ND	188.1	188.10	0.00	
PZ-7 210.48	6/14/93	ND	21.42	ND	189.06	189.06	0
	6/23/95	ND	21.42	ND	189.06	189.06	0
	7/31/95	20.21	20.34	190.27	190.14	190.24	0.13
	9/6/95	21.37	21.44	189.11	189.04	189.09	0.07
	10/24/95	20.47	ND	190.01	ND	ND	*
	1/11/96	20.10	ND	190.38	ND	ND	*
	4/17/96	20.83	21.06	-	*	-	*
	5/16/96	21.34	21.55	-	*	-	*
PZ-8 201.55	6/14/93	ND	11.80	ND	189.75	189.75	0
	2/15/95	NR	NR	NR	NR	NR	NR
	6/23/95	ND	ND	ND	ND	ND	0
	7/31/95	12.18	13.50	189.37	188.05	189.06	1.32
	9/6/95	12.57	13.40	188.98	188.15	188.78	0.83
	10/24/95	11.88	11.90	189.67	189.65	189.67	0.02
	1/11/96	10.88	10.99	190.67	190.56	190.64	0.11
	4/17/96	12.86	-	188.69	*	-	*
5/16/96	13.35	13.59	-	*	-	*	
PZ-9 201.65	6/14/93	ND	10.40	ND	191.25	191.25	0
	2/15/95	ND	10.91	ND	190.74	190.74	0
	6/23/95	ND	ND	ND	ND	ND	0
	7/31/95	NM	12.26	NM	189.39	189.39	NM
	9/6/95	12.76	13.77	188.89	187.88	188.65	1.01
	10/24/95	12.06	ND	189.59	ND	ND	*
	1/11/96	10.85	10.93	190.80	190.72	190.78	0.08
	4/17/96	12.31	12.39	-	*	-	*
5/16/96	13.14	13.16	-	*	-	*	

Table A-3
Free Product / Water Level Measurements
CAFB SS-26

Well ID and Elevation (ft) (BTOC)	Date:	Free Product Depth (ft) (BTOC)	Water Depth (ft) (BTOC)	Free Product Elevation (ft) (BTOC)	Groundwater Elevation (ft) (BTOC) (MSL)	² Corrected Groundwater Elevation (ft)	Free Product Thickness (ft)
PZ-10 209.8	4/17/96	18.95	21.18	-	*	-	*
	5/16/96	18.99	21.15	-	*	-	*
PZ-11 207.74	6/14/93	ND	10.88	ND	196.86	196.86	0
	2/15/95	9.39	10.55	198.35	197.19	198.08	1.16
	6/23/95	ND	ND	ND	ND	ND	0
	8/1/95	8.03	9.85	199.71	197.89	199.28	1.82
	9/6/95	11.42	14.27	196.32	193.47	195.64	2.85
	10/24/95	10.82	12.07	196.92	195.67	196.62	1.25
	1/11/96	9.90	12.15	197.84	195.59	197.31	2.25
	4/17/96	11.03	-	-	*	-	*
	5/16/96	11.17	11.19	-	*	-	*
PZ-12 201.41	6/14/93	ND	8.92	ND	192.49	192.49	0
	2/15/95	ND	8.66	ND	192.75	192.75	0
	6/23/95	ND	10.75	ND	190.66	190.66	0
	8/1/95	10.36	10.41	191.05	191	191.04	0.05
	9/6/95	11.14	11.67	190.27	189.74	190.14	0.53
	10/24/95	10.61	10.63	190.80	190.78	190.80	0.02
	1/11/96	9.41	11.81	192.00	189.60	191.43	2.40
	4/17/96	9.51	9.59	-	*	-	*
	5/16/96	ND	10.97	ND	190.44	190.44	0
PZ-13 206.61	6/14/93	ND	16.85	ND	189.76	189.76	0
	6/26/95	ND	16.46	ND	190.15	190.15	0
	8/1/95	16.28	18.25	190.33	188.36	189.86	1.97
	9/6/95	16.51	18.47	190.10	188.14	189.64	1.96
	10/24/95	16.25	17.92	190.36	188.69	189.96	1.67
	1/11/96	ND	15.64	ND	190.97	190.97	0
	4/17/96	16.53	17.40	-	*	-	*
	5/16/96	16.47	16.48	-	*	-	*
PZ-14 201.89	6/14/93	ND	10.73	ND	191.16	191.16	0
	2/15/95	10.70	11.70	191.19	190.19	190.95	1.00
	6/23/95	ND	12.34	ND	189.55	189.55	0
	8/1/95	12.21	13.01	189.68	188.88	189.49	0.80
	9/6/95	12.47	13.55	189.42	188.34	189.16	1.08
	10/24/95	12.05	12.71	189.84	189.18	189.68	0.66
	1/11/96	10.99	11.58	190.90	190.31	190.76	0.59
	4/17/96	ND	11.67	ND	190.22	190.22	0
	5/16/96	ND	12.31	ND	189.58	189.58	0

Table A-3
Free Product / Water Level Measurements
CAFB SS-26

Well ID and Elevation (ft) (BTOC)	Date:	Free Product Depth (ft) (BTOC)	Water Depth (ft) (BTOC)	Free Product Elevation (ft) (BTOC)	Groundwater Elevation (ft) (BTOC) (MSL)	² Corrected Groundwater Elevation (ft)	Free Product Thickness (ft)
PZ-15 201.12	6/14/93	ND	8.69	ND	192.43	192.43	0
	2/15/95	ND	8.52	ND	192.60	192.60	0
	6/23/95	ND	10.81	ND	190.31	190.31	0
	8/1/95	10.14	11.35	190.98	189.77	190.69	1.21
	9/6/95	ND	11.82	ND	189.3	189.30	0
	10/24/95	10.53	11.19	190.59	189.93	190.43	0.66
	1/11/96	9.73	11.41	191.39	189.71	190.99	1.68
	4/17/96	ND	9.80	ND	191.32	191.32	0
	5/16/96	ND	9.35	ND	191.77	191.77	0
PZ-16 201.98	6/14/93	ND	9.34	ND	192.64	192.64	0
	2/15/95	ND	9.05	ND	192.93	192.93	0
	6/23/95	ND	11.03	ND	190.95	190.95	0
	8/1/95	NM	10.75	NM	191.23	191.23	NM
	9/6/95	ND	11.57	ND	190.41	190.41	0
	10/24/95	ND	11.03	ND	190.95	190.95	0
	1/11/96	10.00	11.28	191.98	190.7	191.68	1.28
	4/17/96	ND	10.01	ND	191.97	191.97	0
	5/16/96	ND	10.11	ND	191.87	191.87	0
PZ-17 200.77	6/14/93	ND	8.60	ND	192.17	192.17	0
	2/15/95	8.42	8.92	192.35	191.85	192.23	0.50
	6/23/95	ND	ND	ND	ND	ND	0
	8/1/95	10.42	11.23	190.35	189.54	190.16	0.81
	9/6/95	11.13	12.30	189.64	188.47	189.36	1.17
	10/24/95	ND	10.56	ND	190.21	190.21	0
	1/11/96	10.13	11.05	190.64	189.72	190.42	0.92
	4/17/96	ND	9.86	ND	190.91	190.91	0
	5/16/96	ND	11.21	ND	189.56	189.56	0
PZ-18 205.74	6/14/93	ND	14.36	ND	191.38	191.38	0
	2/15/95	ND	15.00	ND	190.74	190.74	0
	6/26/95	15.44	>16	190.30	<189.74	<189.74	*
	8/1/95	15.33	16.37	190.41	189.37	190.16	1.04
	9/6/95	13.47	16.52	192.27	189.22	191.55	3.05
	10/24/95	15.25	ND	190.49	ND	ND	*
	1/11/96	ND	14.45	ND	191.29	191.29	0
	4/17/96	ND	15.40	ND	190.34	190.34	0
	5/16/96	ND	15.48	ND	190.26	190.26	0

Table A-3
Free Product / Water Level Measurements
CAFB SS-26

Well ID and Elevation (ft) (BTOC)	Date:	Free Product Depth (ft) (BTOC)	Water Depth (ft) (BTOC)	Free Product Elevation (ft) (BTOC)	Groundwater Elevation (ft) (BTOC) (MSL)	² Corrected Groundwater Elevation (ft)	Free Product Thickness (ft)
PZ-19 201.69	6/14/93	ND	9.48	ND	192.21	192.21	0
	2/15/95	ND	9.56	ND	192.13	192.13	0
	6/26/95	ND	11.39	ND	190.30	190.30	0
	8/1/95	10.99	11.03	190.7	190.66	190.69	0.04
	9/6/95	ND	11.85	ND	189.84	189.84	0
	10/24/95	ND	11.26	ND	190.43	190.43	0
	1/11/96	10.48	12.45	191.21	189.24	190.74	1.97
	4/17/96	ND	10.41	ND	191.28	191.28	0
	5/16/96	ND	12.12	ND	189.57	189.57	0
PZ-20 201.83	6/14/93	ND	12.38	ND	189.45	189.45	0
	2/15/95	ND	12.25	ND	189.58	189.58	0
	6/26/95	ND	11.20	ND	190.63	190.63	0
	8/1/95	10.77	11.14	191.06	190.69	190.97	0.37
	9/6/95	ND	11.26	ND	190.57	190.57	0
	10/24/95	11.03	13.12	190.80	188.71	190.30	2.09
	1/11/96	9.99	12.73	191.84	189.1	191.19	2.74
	4/17/96	10.64	12.52	-	*	-	*
	5/16/96	11.03	13.21	-	*	-	*
VE-1 207.98	6/14/93	16.74	18.65	191.24	189.33	190.79	1.91
	2/17/95	18.25	19.86	189.73	188.12	189.35	1.61
	6/26/95	18.81	20.08	189.17	187.9	188.87	1.27
	7/28/95	17.17	20	190.81	188.04	190.15	2.77
	9/6/95	17.79	20.12	190.19	187.86	189.64	2.33
	10/24/95	18.58	19.51	189.40	188.47	189.18	0.93
	1/11/96	17.58	19.05	190.40	188.93	190.05	1.47
	4/17/96	18.61	19.12	189.37	188.86	189.25	0.51
	5/16/96	18.28	19.96	189.70	188.02	189.30	1.68
VE-2 209.02	6/14/93	15.83	18.43	193.19	190.59	192.57	2.60
	2/17/95	18.65	21.28	190.37	187.74	189.75	2.63
	6/26/95	19.41	21.18	189.61	187.84	189.19	1.77
	7/28/95	18.80	21.24	190.22	187.78	189.64	2.44
	9/6/95	18.85	20.20	190.17	188.82	189.85	1.35
	10/24/95	18.58	20.97	190.44	188.05	189.87	2.39
	1/11/96	18.15	19.71	190.87	189.31	190.50	1.56
	4/17/96	19.12	20.75	189.90	188.27	189.51	1.63
	5/16/96	ND	18.59	ND	190.43	190.43	0

Table A-3
Free Product / Water Level Measurements
CAFB SS-26

Well ID and Elevation (ft) (BTOC)	Date:	Free Product Depth (ft) (BTOC)	Water Depth (ft) (BTOC)	Free Product Elevation (ft) (BTOC)	Groundwater Elevation (ft) (BTOC) (MSL)	² Corrected Groundwater Elevation (ft)	Free Product Thickness (ft)
VE-3 205.69	6/14/93	ND	14.62	ND	191.07	191.07	0
	2/18/95	14.47	16.32	191.22	189.37	190.78	1.85
	2/17/95	14.90	17.11	190.79	188.58	190.27	2.21
	6/26/95	15.91	17.66	189.78	188.03	189.37	1.75
	8/1/95	15.32	18.25	190.37	187.44	189.68	2.93
	9/6/95	14.71	17.55	190.98	188.14	190.31	2.84
	10/24/95	15.15	17.63	190.54	188.06	189.95	2.48
	1/11/96	14.71	15.46	190.98	190.23	190.80	0.75
	4/17/96	15.13	18.36	190.56	187.33	189.79	3.23
	5/17/96	14.92	18.26	190.77	187.43	189.98	3.34
VE-4 202.27	6/14/93	11.55	12.65	190.72	189.62	190.46	1.10
	2/17/95	11.68	13.12	190.59	189.15	190.25	1.44
	6/26/95	12.37	14.20	189.90	188.07	189.47	1.83
	7/28/95	11.21	13.73	191.06	188.54	190.46	2.52
	9/6/95	11.29	14.15	190.98	188.12	190.30	2.86
	10/24/95	12.42	13.03	189.85	189.24	189.71	0.61
	1/11/96	11.58	11.72	190.69	190.55	190.66	0.14
	4/17/96	ND	12.03	ND	190.24	190.24	0
5/16/96	ND	11.22	ND	191.05	191.05	0	
VE-5 205.9	6/14/93	15.65	15.69	190.25	190.21	190.24	0.04
	2/18/95	14.53	16.40	191.37	189.50	190.93	1.87
	6/26/95	15.91	17.26	189.99	188.64	189.67	1.35
	8/1/95	15.49	16.81	190.41	189.09	190.10	1.32
	9/6/95	14.81	16.45	191.09	189.45	190.70	1.64
	10/24/95	15.48	17.14	190.42	188.76	190.03	1.66
	1/11/96	14.57	16.39	191.33	189.51	190.90	1.82
	4/17/96	15.38	17.38	190.52	188.52	190.05	2.00
5/17/96	14.44	17.72	191.46	188.18	190.68	3.28	
VE-6 203.27	6/14/93	11.97	13.26	191.30	190.01	190.99	1.29
	2/15/95	11.55	12.64	191.72	190.63	191.46	1.09
	6/26/95	12.40	12.92	190.87	190.35	190.75	0.52
	7/31/95	10.09	12.84	193.18	190.43	192.53	2.75
	9/6/95	11.56	14.01	191.71	189.26	191.13	2.45
	10/24/95	12.43	14.13	190.84	189.14	190.44	1.70
	1/11/96	10.56	13.10	192.71	190.17	192.11	2.54
	4/17/96	12.02	13.89	191.25	189.38	190.81	1.87
5/16/96	ND	10.72	ND	192.55	192.55	0	

Table A-3
Free Product / Water Level Measurements
CAFB SS-26

Well ID and Elevation (ft) (BTOC)	Date:	Free Product Depth (ft) (BTOC)	Water Depth (ft) (BTOC)	Free Product Elevation (ft) (BTOC)	Groundwater Elevation (ft) (BTOC) (MSL)	² Corrected Groundwater Elevation (ft)	Free Product Thickness (ft)
VE-7 200.07	6/14/93	NR	NR	NR	NR	NR	NR
	2/15/95	9.11	9.58	190.96	190.49	190.85	0.47
	6/26/95	ND	12.18	ND	187.89	187.89	0
	7/31/95	NM	10.11	NM	189.96	189.96	NM
	9/7/95	11.68	11.69	188.39	188.38	188.39	0.01
	10/24/95	10.45	10.46	189.62	189.61	189.62	0.01
	1/11/96	9.05	9.06	191.02	191.01	191.02	0.01
	2/28/96	ND	10.25	ND	189.82	189.82	0
	4/17/96	ND	11.42	ND	188.65	188.65	0
	5/16/96	ND	11.09	ND	188.98	188.98	0
VE-8 200.25	6/14/93	NR	NR	NR	NR	NR	NR
	2/17/95	10.67	10.69	189.58	189.56	189.58	0.02
	6/26/95	ND	11.47	ND	188.78	188.78	0
	7/31/95	NM	9.38	NM	190.87	190.87	NM
	9/7/95	10.75	10.76	189.50	189.49	189.50	0.01
	10/24/95	9.35	10.14	190.90	190.11	190.71	0.79
	1/11/96	9.34	9.93	190.91	190.32	190.77	0.59
	4/17/96	10.49	11.32	189.76	188.93	189.56	0.83
	5/16/96	10.38	11.88	189.87	188.37	189.51	1.5
VE-9 198.97	6/14/93	NR	NR	NR	NR	NR	NR
	2/18/95	8.08	8.95	190.89	190.02	190.68	0.87
	6/26/95	10.14	10.41	188.83	188.56	188.77	0.27
	7/28/95	8.70	8.98	190.27	189.99	190.20	0.28
	9/6/95	8.85	9.02	190.12	189.95	190.08	0.17
	10/24/95	9.48	9.66	189.49	189.31	189.45	0.18
	1/11/96	9.24	10.00	189.73	188.97	189.55	0.76
	4/17/96	9.09	9.91	189.88	189.06	189.69	0.82
5/16/96	10.52	11.12	188.45	187.85	188.31	0.60	
VI-1 208.19	6/14/93	15.60	16.62	192.59	191.57	192.35	1.02
	2/15/95	18.03	19.50	190.16	188.69	189.81	1.47
	2/17/95	18.30	20.71	189.89	187.48	189.32	2.41
	7/28/95	20.28	20.50	187.91	187.69	187.86	0.22
	9/7/95	20.56	20.58	187.63	187.61	187.63	0.02
	10/24/95	ND	18.76	ND	189.43	189.43	0
	1/11/96	19.51	19.52	188.68	188.67	188.68	0.01
	2/28/96	ND	18.54	ND	189.65	189.65	0
	4/17/96	19.31	19.32	188.88	188.87	188.88	0.01
5/16/96	ND	21.23	ND	186.96	186.96	0	

Table A-3
Free Product / Water Level Measurements
CAFB SS-26

Well ID and Elevation (ft) (BTOC)	Date:	Free Product Depth (ft) (BTOC)	Water Depth (ft) (BTOC)	Free Product Elevation (ft) (BTOC)	Groundwater Elevation (ft) (BTOC) (MSL)	² Corrected Groundwater Elevation (ft)	Free Product Thickness (ft)
VI-2 209.21	6/14/93	18.80	20.79	190.41	188.42	189.94	1.99
	2/17/95	19.51	21.64	189.70	187.57	189.20	2.13
	7/28/95	NM	21.65	NM	187.56	187.56	NM
	9/6/95	ND	21.13	ND	188.08	188.08	0
	10/24/95	ND	19.50	ND	189.71	189.71	0
	1/11/96	19.55	19.56	189.66	189.65	189.66	0.01
	2/28/96	ND	19.46	ND	189.75	189.75	0
	4/17/96	ND	20.87	ND	188.34	188.34	0
5/16/96	ND	21.79	ND	187.42	187.42	0	
VI-3 206.38	6/14/93	16.49	18.57	189.89	187.81	189.40	2.08
	2/15/95	15.14	16.85	191.24	189.53	190.83	1.71
	2/17/95	16.15	18.27	190.23	188.11	189.73	2.12
	7/28/95	18.18	18.20	188.20	188.18	188.20	0.02
	9/6/95	17.24	18.20	189.14	188.18	188.91	0.96
	10/24/95	16.54	16.85	189.84	189.53	189.77	0.31
	1/11/96	16.30	16.40	190.08	189.98	190.06	0.10
	4/17/96	ND	16.92	ND	189.46	189.46	0
5/16/96	18.29	18.33	188.09	188.05	188.08	0.04	
VI-4 203.15	6/14/93	ND	10.47	ND	192.68	195.91	0
	2/15/95	ND	11.74	ND	191.41	194.64	0
	7/28/95	NM	14.76	NM	188.39	188.39	NM
	9/6/95	ND	14.46	ND	188.69	191.92	0
	10/24/95	ND	13.55	ND	189.60	192.83	0
	1/11/96	12.79	12.80	190.36	190.35	193.59	0.01
	2/28/96	ND	13.81	ND	189.34	192.57	0
	4/17/96	ND	12.75	ND	190.40	190.40	0
5/16/96	ND	13.36	ND	189.79	193.02	0	
W-11 200.26	2/15/95	ND	6.95	ND	193.31	193.31	0
	9/7/95	ND	8.99	ND	191.27	191.27	0
	10/24/95	ND	8.84	ND	191.42	191.42	0
	1/11/96	ND	7.34	ND	192.92	192.92	0
	4/17/96	ND	7.76	ND	192.50	192.50	0
	5/16/96	ND	8.74	ND	191.52	191.52	0
W-14 NS	1/11/96	10.81	10.82	-	-	-	0.01
	2/28/96	NM	NM	NM	NM	-	NM
	4/17/96	ND	11.37	ND	-	-	0
	5/17/96	ND	12.13	-	-	-	0
W-16 NS	2/15/95	ND	19.15	ND	-	-	0
	9/6/95	ND	15.35	ND	-	-	0
	10/24/95	NM	NM	NM	-	-	NM
	1/11/96	ND	13.80	ND	-	-	0
	4/17/96	ND	14.70	ND	-	-	0
	5/16/96	ND	14.98	ND	-	-	0

Table A-3
Free Product / Water Level Measurements
CAFB SS-26

Well ID and Elevation (ft) (BTOC)	Date:	Free Product Depth (ft) (BTOC)	Water Depth (ft) (BTOC)	Free Product Elevation (ft) (BTOC)	Groundwater Elevation (ft) (BTOC) (MSL)	² Corrected Groundwater Elevation (ft)	Free Product Thickness (ft)
W-17 210.03	2/15/95	18.98	21.20	191.05	188.83	190.52	2.22
	7/31/95	21.91	21.93	188.12	188.10	188.12	0.02
	9/7/95	22.20	22.41	187.83	187.62	187.78	0.21
	10/24/95	ND	20.28	ND	189.75	189.75	0
	1/11/96	20.26	20.27	189.77	189.76	189.77	0.01
	2/28/96	ND	20.22	ND	189.81	189.81	0
	4/17/96	ND	21.53	ND	188.50	188.50	0
	5/16/96	22.21	22.22	187.82	187.81	187.82	0.01
W-39 NS	1/11/96	ND	4.38	-	-	-	0
	4/17/96	ND	4.71	-	-	-	0
	5/17/96	ND	5.51	-	-	-	0
W-40 198.68	2/17/95	6.56	7.57	192.12	191.11	191.88	1.01
	7/31/95	NM	8.34	NM	190.34	190.34	NM
	9/6/95	8.95	9.29	189.73	189.39	189.65	0.34
	10/24/95	6.19	6.20	192.49	192.48	192.49	0.01
	1/11/96	7.10	7.35	191.58	191.33	191.52	0.25
	4/17/96	7.71	8.53	190.97	190.15	190.78	0.82
	5/16/96	ND	8.72	ND	189.96	189.96	0
W-42 196.1	3/9/95	-	-	-	-	-	0.01
	7/31/95	6.60	6.65	189.50	189.45	189.49	0.05
	9/6/95	7.05	7.54	189.05	188.56	188.93	0.49
	10/24/95	6.57	6.59	189.53	189.51	189.53	0.02
	1/11/96	5.30	5.65	190.80	190.45	190.72	0.35
	4/17/96	ND	6.14	ND	189.96	189.96	0
	5/16/96	ND	8.97	ND	187.13	187.13	0
W-43 198.56	2/13/95	ND	8.60	ND	189.96	189.96	0
	2/15/95	ND	8.60	ND	189.96	189.96	0
	2/14/95	ND	8.60	ND	189.96	189.96	0
	9/7/95	ND	9.49	ND	189.07	189.07	0
	1/11/96	ND	5.49	ND	193.07	193.07	0
	4/17/96	ND	8.86	ND	189.70	189.70	0
W-44 198.76	1/11/96	ND	6.31	ND	192.45	192.45	0
	4/17/96	ND	6.81	ND	191.95	191.95	0
	5/16/96	ND	9.12	ND	189.64	189.64	0

Table A-3
Free Product / Water Level Measurements
CAFB SS-26

Well ID and Elevation (ft) (BTOC)	Date:	Free Product Depth (ft) (BTOC)	Water Depth (ft) (BTOC)	Free Product Elevation (ft) (BTOC)	Groundwater Elevation (ft) (BTOC) (MSL)	² Corrected Groundwater Elevation (ft)	Free Product Thickness (ft)
W-46 210.57	2/15/95	ND	20.17	ND	190.40	190.40	0
	7/31/95	21.61	21.65	188.96	188.92	188.95	0.04
	9/7/95	21.95	21.96	188.62	188.61	188.62	0.01
	10/24/95	ND	20.71	ND	189.86	189.86	0
	1/11/96	20.38	20.39	190.19	190.18	190.19	0.01
	2/28/96	ND	20.61	ND	189.96	189.96	0
	4/17/96	ND	21.36	ND	189.21	189.21	0
	5/16/96	ND	21.96	ND	188.61	188.61	0

Legend

BTOC = Below Top of Casing

F = Free product recovery well

M = Monitoring well

ND = Not Detected

NM = Not Measured

* = Free product encountered, thickness not accurately measureable in 1" I.D. Piezometers.

(1) Well dry.

(2) Corrected Groundwater Elevation = Groundwater Elevation + (Product Thickness * Jet Fuel Density of 0.763)

(3) If free product was detected in a piezometer, it was noted. Due to the small diameter of the piezometers, the oil/water interface probe could not accurately measure free product thicknesses. We suspect that electrical interferences occur between the probe and a small diameter well.

NW = No water

PZ = Piezometer

R = Recovery well

VE = Vapor extraction well

VI = Vapor injection well

MSL = Mean Sea Level

NS = Not surveyed

- = Not Applicable

APPENDIX B

Well Details

WELL NO.	APPROX. ELEV. OF TOP OF SCREEN (FEET)	APPROX. ELEV. OF BOTTOM OF SCREEN (FEET)	APPROX. DEPTH OF WELL (FEET)	ACTUAL DEPTH OF WELL INSTALLED
R-1	199	176	23	
R-2	205	177	28	
R-3	207	177	30	
R-4	205	177	28	
R-5	199	178.8	20.2	
R-6	199	179	20	
R-7	199	179	20	
V-47	200	178	22	
V-48	199	176	23	
V-49	201	178	23	
V-50	199	180	19	
V-51	200	176	24	

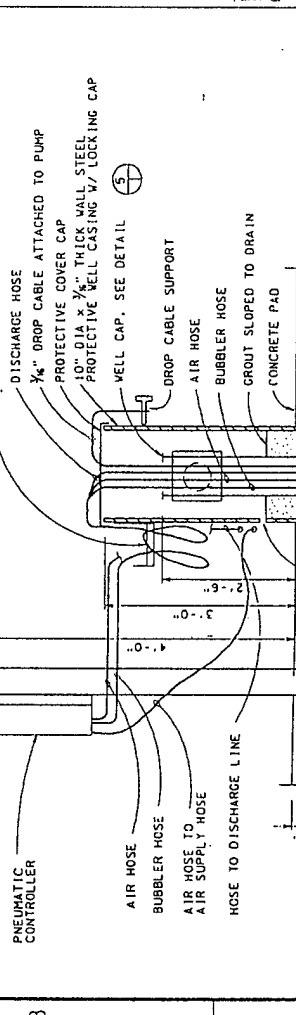
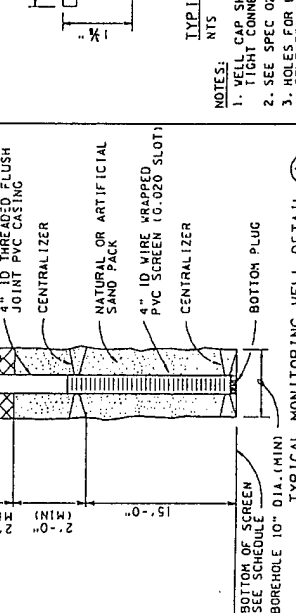
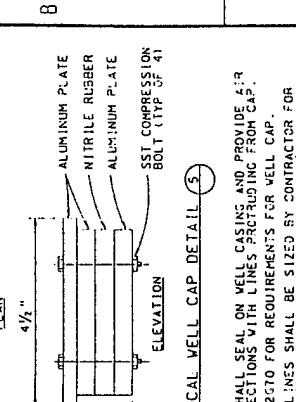
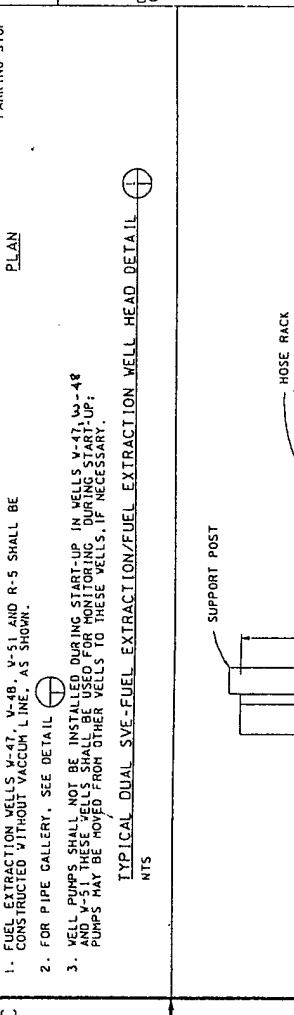
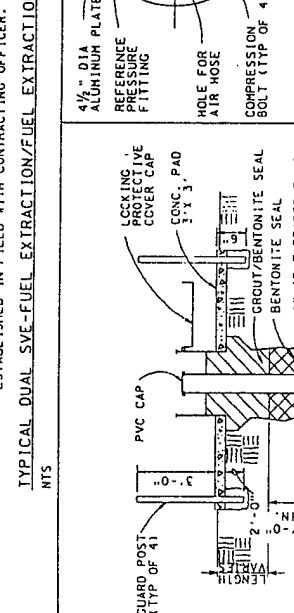
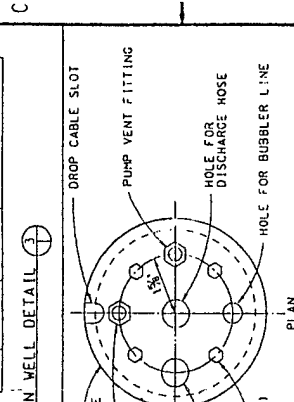
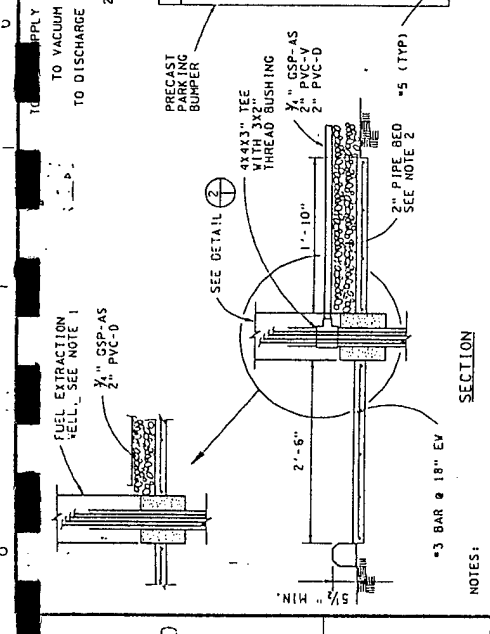
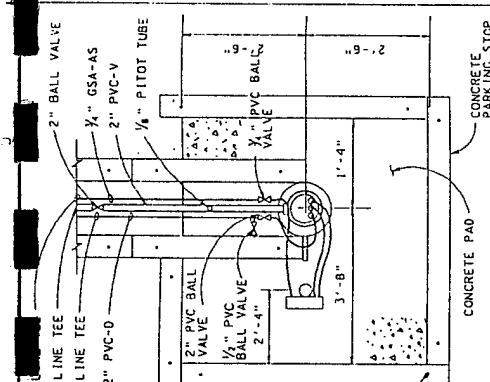
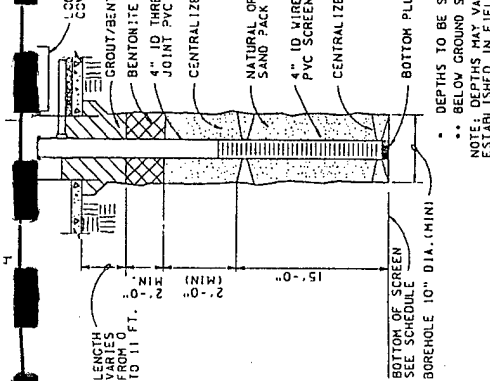
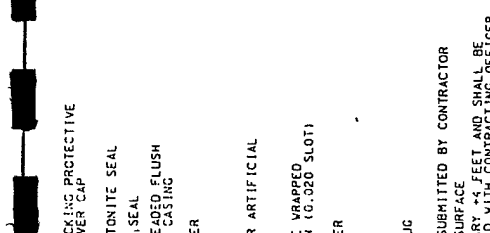

DESIGN	DRAWING	DATE	BY
1	1	1	1
2	2	2	2
3	3	3	3
4	4	4	4
5	5	5	5
6	6	6	6
7	7	7	7
8	8	8	8
9	9	9	9
10	10	10	10

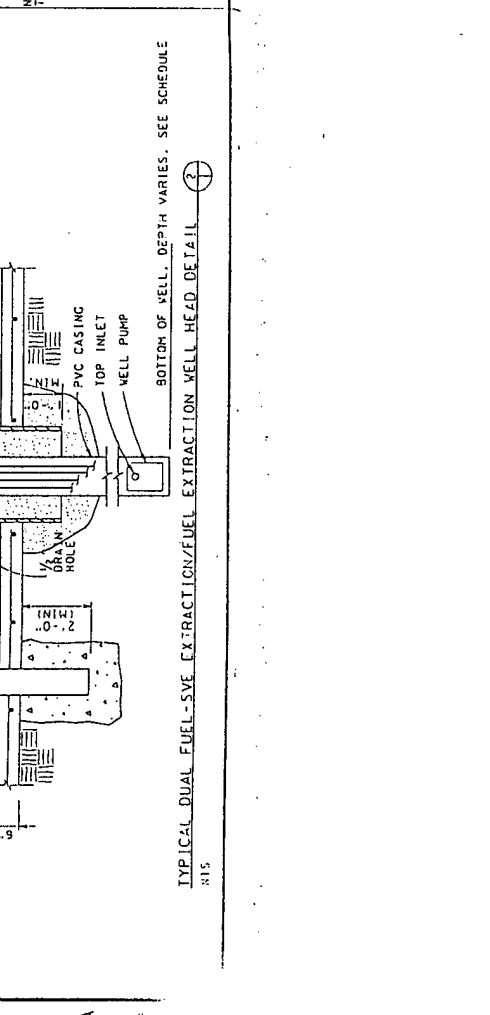
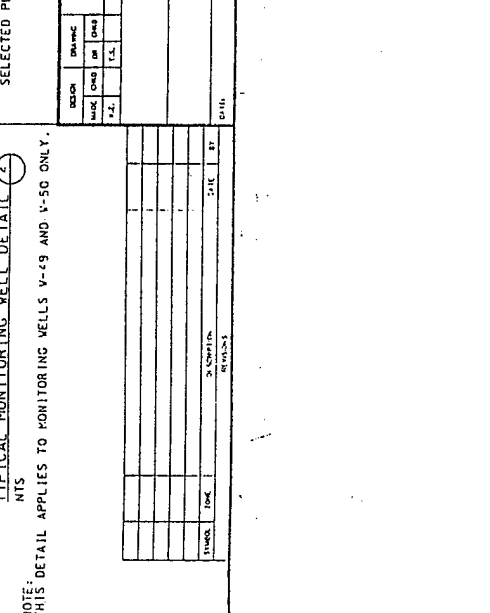

NO.	DATE	BY	REVISION
1			
2			
3			
4			
5			
6			
7			
8			
9			
10			

ATLANTA, GEORGIA
COLUMBUS AFB
SPILL SITE 5 REMEDIATION
DETAILS
COLUMBUS AFB
PROJECT NO. 1
D
SCALE: AS SHOWN
DATE: 11-1-82

APPENDIX C

Geological Cross-Sections/Soil Boring Logs

See Figure 3-15. for Cross-section Location.

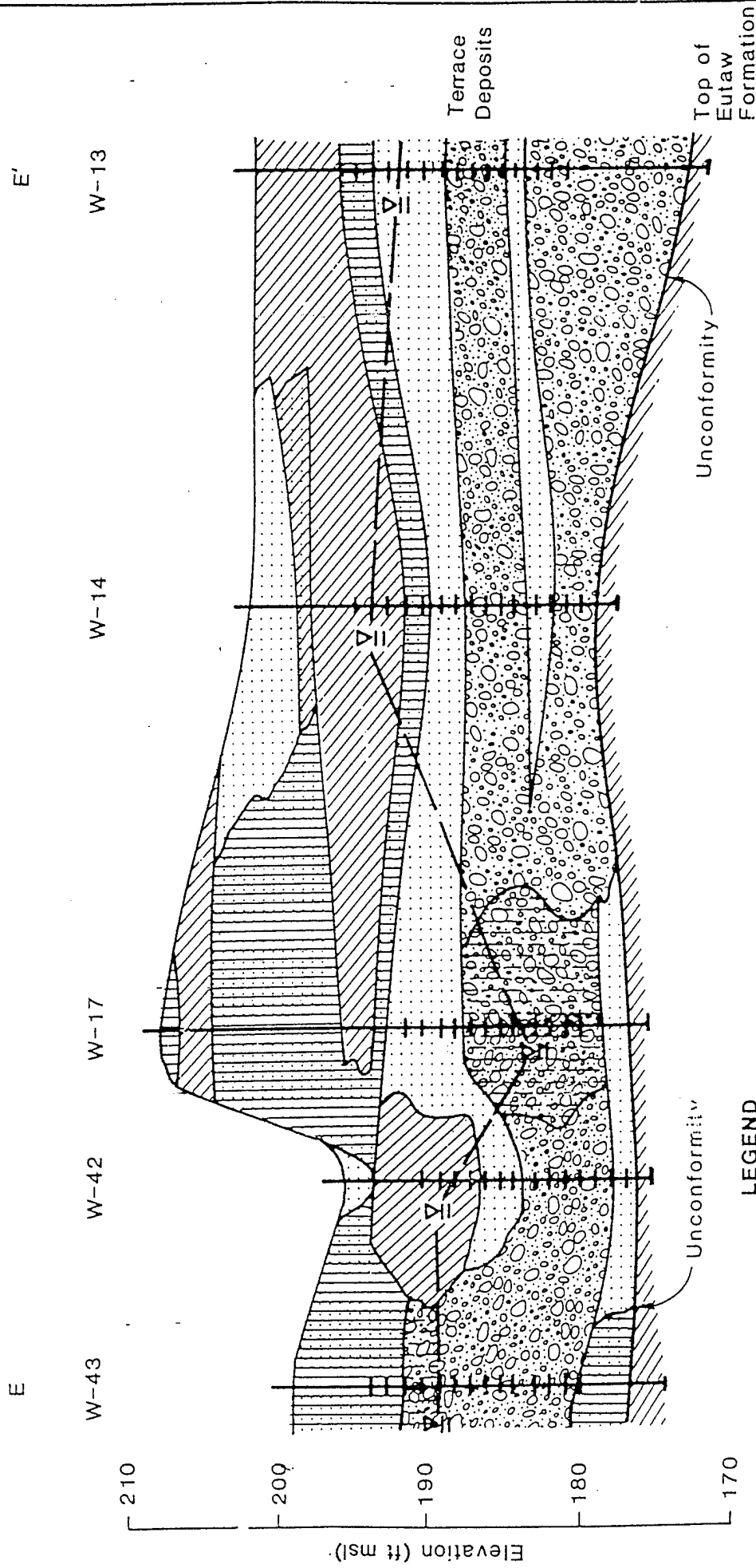

LEGEND

	Gravel and Sand		Depth of Boring
	Silty Gravel and Sand		Potentiometric Surface Elevation
	Clayey Gravel and Sand		Water Level
	Sand		Top of Eutaw Formation
	Silty Sand		Screen Interval
	Sand and Clay		
	Silt		
	Clay		
	Fill, Variable Composition		

Horizontal Scale : 1" = 140'

FIGURE 3-16.
 Geologic Cross Section E-E'
 Area 3, Spill Site 5.
 Columbus AFB, Mississippi.



See Figure 3-15. for Cross-section Location.

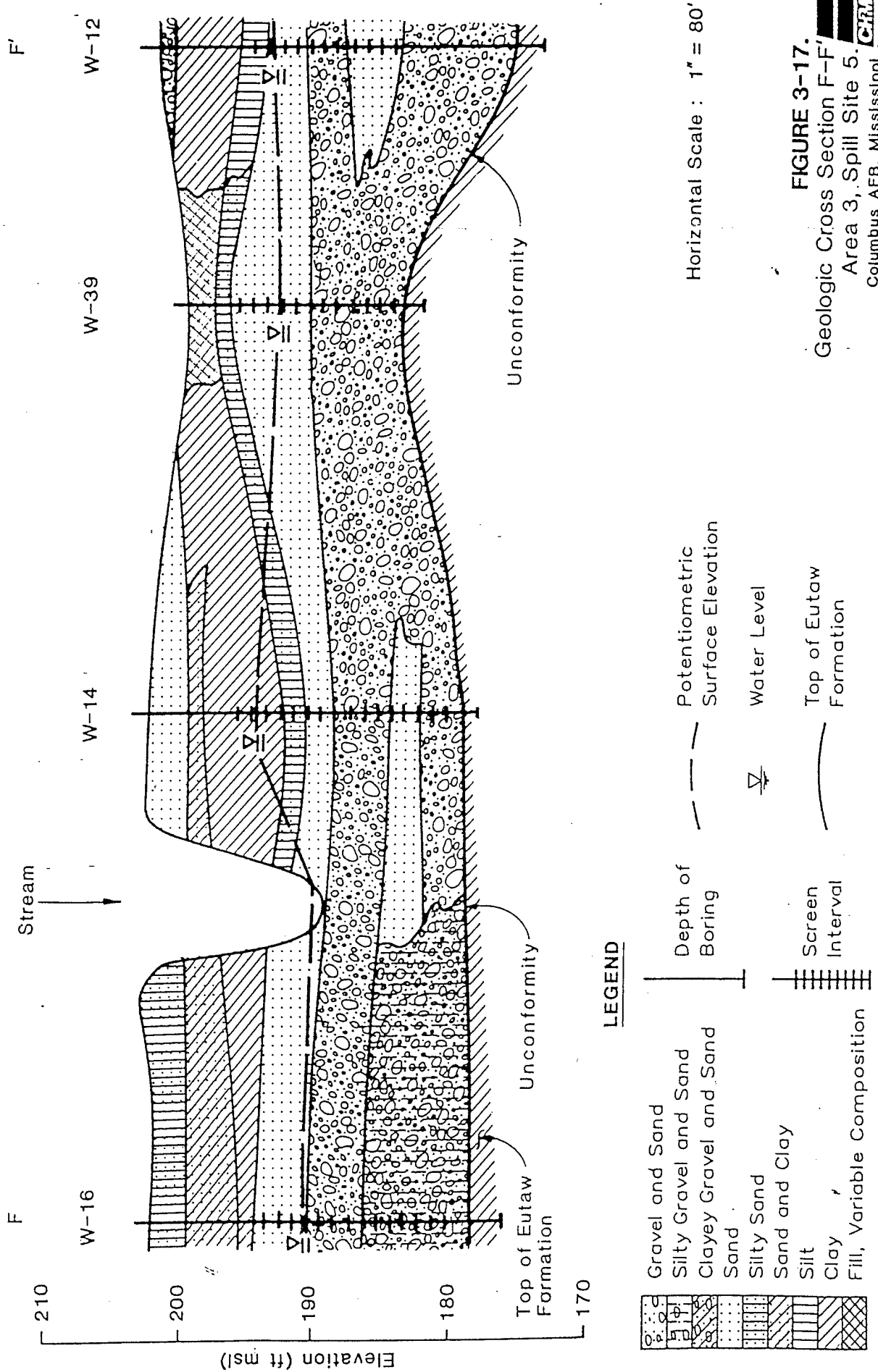
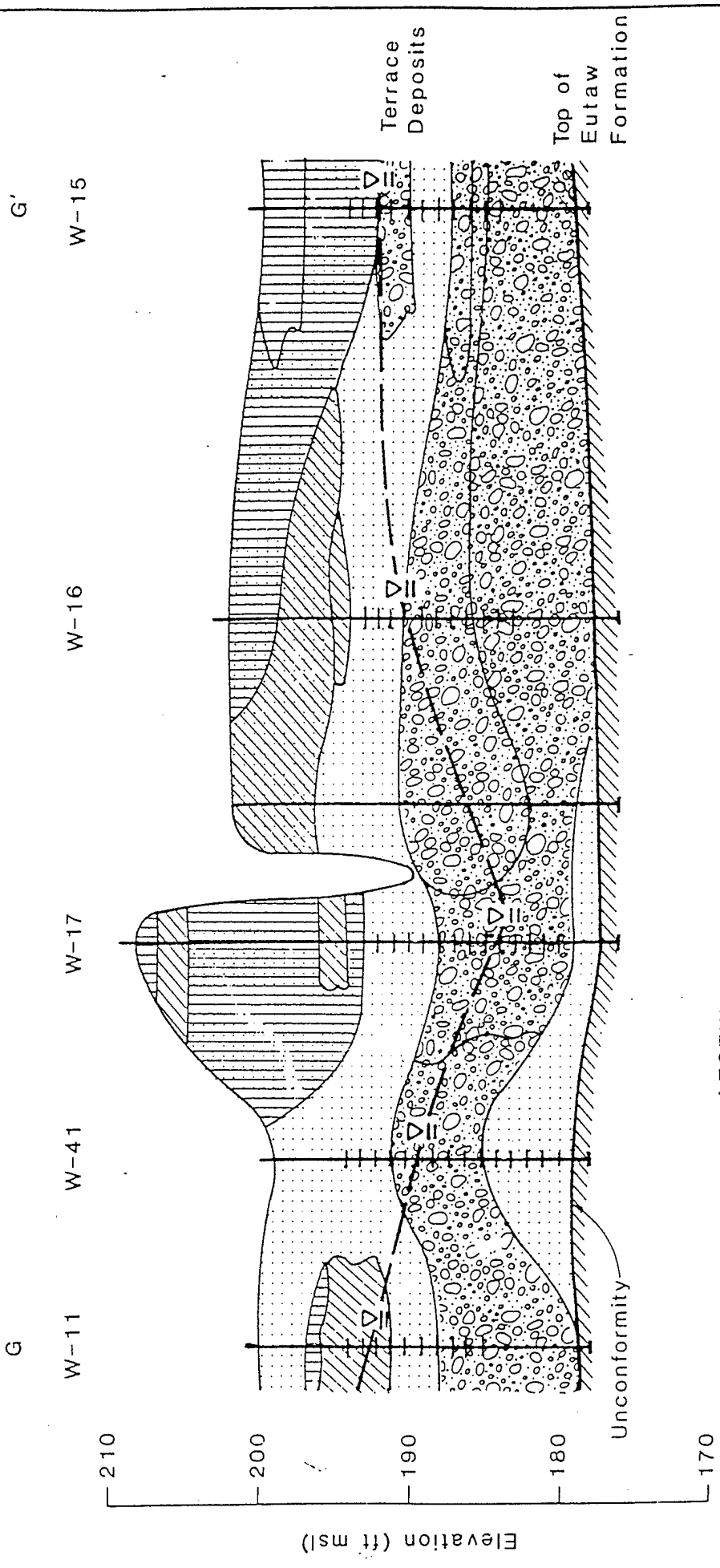

FIGURE 3-17.
 Geologic Cross Section F-F'
 Area 3, Spill Site 5.
 Columbus AFB, Mississippi.



See Figure 3-15. for Cross-section Location.



- LEGEND**
- Gravel and Sand
 - Silty Gravel and Sand
 - Clayey Gravel and Sand
 - Sand
 - Silty Sand
 - Sand and Clay
 - Silt
 - Clay
 - Fill, Variable Composition
 - Depth of Boring
 - Screen Interval
 - Potentiometric Surface Elevation
 - Water Level
 - Top of Eutaw Formation

Horizontal Scale : 1" = 100'

FIGURE 3-18.
 Geologic Cross Section G-G'
 Area 3, Spill Site 5.
 Columbus AFB, Mississippi.



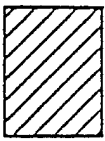

CLAY (CL, CH, OL, OH)



SANDY SILT WITH GRAVEL,
SILTY SAND WITH GRAVEL,
(ML, MH, SM, SP-SM, SW-SM,
GM, GP-GM, GW-GM, OL, OH)

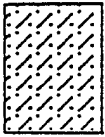

CLAYEY SAND, SAND WITH
CLAY (SC, SP-SC, SW-SC)



SILTY SAND, SAND WITH SILT
(SM, SP-SM)

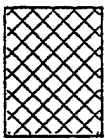

FILL, REFUSE



SILT (ML, MH, OL, OH)

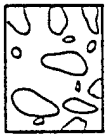

GRAVEL (GW, GP)

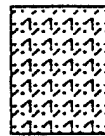

SILTY CLAYEY SAND (SC-SM)

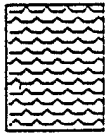

PEAT (OH, OL)



SANDY CLAY WITH GRAVEL,
CLAYEY SAND WITH GRAVEL
(CL, CH, SC, SP-SC, SW-SC,
GC, GP-GC, GW-GC)

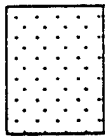

SAND (SW, SP)



SANDY SILT (ML, MH, OL, OH)

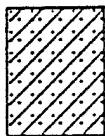

SANDY CLAY (CL, CH, OL, OH)

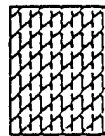

SILTY CLAY (CL-ML)



SANDY GRAVEL, GRAVELLY SAND
(SP, SW, GW, GP)



PROJECT COLUMBUS AFB RI LOCATION SS-5, AREA 3
 ELEVATION 195.91 (ft. msl) DRILLING CONTRACTOR BURMAH TECHNICAL SERVICES
 DRILLING METHOD AND EQUIPMENT HOLLOW STEM AUGER / MOBILE B-56
 WATER LEVEL AND DATE 9.0' (bgs) 3/17/88 START 3/17/88 FINISH 3/17/88 LOGGER J.R. BROWNFIELD

DEPTH BELOW SURFACE (FT)	SAMPLE			STANDARD PENETRATION TEST RESULTS	SOIL DESCRIPTION	SYMBOLIC LOG	COMMENTS
	INTERVAL	TYPE AND NUMBER	RECOVERY (IN)	6'-6" 6'-6"	SOIL NAME, COLOR, MOISTURE CONTENT, RELATIVE DENSITY OR CONSISTENCY, SOIL STRUCTURE, MINERALOGY, USCS GROUP SYMBOL		DEPTH OF CASING, DRILLING RATE, DRILLING FLUID LOSS, TESTS AND INSTRUMENTATION
		S-1	20"	10-12 7-4	GRAVEL; red to brown, moist, 20% silt, 20% sand. (FILL)	X	Using 300lb. hammer and 3" split spoon.
		S-2	22"	3-2 5-7	CLAY; gray, moist, 20% silt. (CL)	/	
5		S-3	24"	3-4 4-10	- - -; orange to tan fine sand, brown organic areas. (CL)	/	Vinyl chloride test negative 1220
		S-4	24"	3-6 6-7	CLAY; gray, moist, 20% silt. (CL)	/	HNu reading in borehole = 20ppm in breathing zone = 2ppm CSL soil sample 1240
10		S-5	24"	3-6 10-12	SAND; gray to tan, wet, fine to medium. (SP)	.	
		S-6	24"	4-9 10-16	- - -; medium grain. (SP)	.	HNu reading in borehole = 15ppm in breathing zone = 2ppm CSL soil sample 1240
		S-7	24"	7-20 20-21	GRAVEL; tan, wet, 10% sand, 3/4" max. size, no fines. (GW)	o	
15		S-8	20"	5-18 18-14	- - -	o	CSL soil sample 1255
		S-9	-	4-7 12-10	- - -; <5% sand. (GW)	o	HNu reading in borehole = 3ppm in breathing zone = 1ppm
20		S-10	-	4-2 5-9	SAND; tan with black grains, wet, fine, no fines. (SP)	.	
					BORING TERMINATED @ 20'		Installed temporary casing, pulled casing and grouted to surface. 3/29/88 (W-42) Free product @ 9ft. Installed monitor well screened interval 3'-18' HNu readings on soil headspace; 7' = 3ppm 9' = 150ppm 11' = 170ppm 13' = 100ppm 15' = 100ppm 17' = 40ppm 19' = 2ppm

NOTE: SOIL DESCRIPTIONS ON THIS LOG ARE A SUMMARY OF FIELD LOGS, VISUAL CLASSIFICATIONS, OR LABORATORY TESTS, IF ANY DISB86ACAD

PROJECT COLUMBUS AFB RI LOCATION SS-5, AREA 3
 ELEVATION 200.26 (ft. msl) DRILLING CONTRACTOR BURMAH TECHNICAL SERVICES
 DRILLING METHOD AND EQUIPMENT HOLLOW STEM AUGER / MOBILE B-56
 WATER LEVEL AND DATE 191.88' (msl) 4/13/88 START 3/11/88 FINISH 3/11/88 LOGGER J.R. BROWNFIELD

DEPTH BELOW SURFACE (FT.)	SAMPLE			STANDARD PENETRATION TEST RESULTS	SOIL DESCRIPTION	SYMBOLIC LOG	COMMENTS
	INTERVAL	TYPE AND NUMBER	RECOVERY (IN)	6"-6" 6"-6"	SOIL NAME, COLOR, MOISTURE CONTENT, RELATIVE DENSITY OR CONSISTENCY, SOIL STRUCTURE, MINERALOGY, USCS GROUP SYMBOL		DEPTH OF CASING, DRILLING RATE, DRILLING FLUID LOSS, TESTS AND INSTRUMENTATION
0		S-1	8"	5-9 5-9	SAND; brown, moist, fine, 20% silt, roots. (SP)		
		S-2	8"	5-8 10-15	--- SILT; gray, moist, 20% clay. (ML)		
5		S-3	18"	4-5 17-24	CLAY; gray, moist, 30% silt. (CL)		
		S-4	18"	9-29 37-42	---		CSL Soil Sample
		S-5	18"	6-8 10-11	--- SAND; gray, wet, very fine < 5% silt. (SP)		LEL-02 = 3-21% HNU reading in borehole and breathing zone = 0ppm CSL Soil Sample
10		S-6	18"	4-7 12-18	SAND; gray to tan, wet, medium to coarse, silt < 5% (SP)		
		S-7	18"	21-28 31-46	GRAVEL; tan, wet, 1/2" max., 5% sand, silt < 5% (GW)		LEL-02 = 2-21% HNU reading in borehole and breathing zone = 0ppm
15		S-8	18"	15-36 41-34	---; 10% sand. (GW)		CSL Soil Sample
		S-9	8"	10-19 22-18	---; orange to tan. (GW)		Vinyl chloride test negative
		S-10	14"	12-18 30-33	GRAVEL; tan, wet, 1 1/2" max., 20% sand, silt < 5% (GW)		
20		S-11	-	14-6 12-20	--- CLAY; dark gray, hard, moist, 10% sand. (CL)		HNU readings on soil headspace = 0-2.8ppm
					BORING TERMINATED @ 22'		Installed monitor well screened interval 6.0'-16.0' pH = 4.5 Cond. = 180 umhos

NOTE: SOIL DESCRIPTIONS ON THIS LOG ARE A SUMMARY OF FIELD LOGS, VISUAL CLASSIFICATIONS, OR LABORATORY TESTS, IF ANY D1386ACAD

PROJECT COLUMBUS AFB RI LOCATION SS-5, AREA 3
 ELEVATION 202.30 (ft. msl) DRILLING CONTRACTOR BURMAH TECHNICAL SERVICES
 DRILLING METHOD AND EQUIPMENT HOLLOW STEM AUGER / MOBILE B-56 / ARDCO ATV
 WATER LEVEL AND DATE 194.01' (msl) 4/13/88 START 3/12/88 FINISH 3/12/88 LOGGER J. HOLLOWAY

DEPTH BELOW SURFACE (FT)	SAMPLE			STANDARD PENETRATION TEST RESULTS 6'-6' 6'-6'	SOIL DESCRIPTION SOIL NAME, COLOR, MOISTURE CONTENT, RELATIVE DENSITY OR CONSISTENCY, SOIL STRUCTURE, MINERALOGY, USCS GROUP SYMBOL	SYMBOLIC LOG	COMMENTS DEPTH OF CASING, DRILLING RATE, DRILLING FLUID LOSS, TESTS AND INSTRUMENTATION
	INTERVAL	TYPE AND NUMBER	RECOVERY (IN)				
0		S-1	18"	10-17 19-19	<u>WELL GRADED SAND WITH GRAVEL</u> ; brown, moist, fine to coarse sand, loose, fine rounded quartz gravel, fines <15% (SW)	•••••	HNu reading on soil = 0ppm
		S-2	24"	4-5 5-3	-- --; wet (SW) <u>CLAYEY SAND</u> ; gray-brown, moist, coarse, medium, mottled, clay >30% (SC)	/ / / / /	
5		S-3	24"	2-2 7-12	<u>SANDY CLAY</u> ; gray-brown, moist, stiff, mottled, coarse quartz sand, sand <30% (CL)	/ / / / /	
		S-4	24"	7-15 19-21	-- --	/ / / / /	CSL Soil Sample
		S-5	24"	5-4 3-14	-- --	/ / / / /	
10		S-6	24"	2-4 7-9	<u>SILTY SAND</u> ; green-gray, wet, fine, loose, silt <15% (SM)		HNu reading on soil = 80ppm
		S-7	18"	5-7 9-11	<u>POORLY SORTED SAND WITH SILT</u> ; brown, fine, loose, silt <10% (SP)	•••••	CSL Soil Sample
15		S-8	16"	5-8 16-18	<u>WELL GRADED SAND AND GRAVEL</u> ; tan, fine to coarse, loose, rounded quartz gravel, silt <5% (SW/GW)	•••••	HNu reading on soil = 22ppm
		S-9	20"	5-9 9-12	-- --	•••••	
		S-10	20"	5-5 7-12	<u>WELL GRADED SAND WITH GRAVEL</u> ; brown, fine to coarse, loose, fine to medium rounded quartz gravel, silt <10% (SW)	•••••	
20		S-11	20"	3-10 11-11	<u>WELL GRADED GRAVEL WITH SAND</u> ; brown, fine to coarse, loose, fine to coarse sand, silt <10% (GW)	•••••	
		S-12	24"	3-7 4-8	-- -- <u>SILTY CLAY WITH SAND</u> ; dark gray, dry, hard, fine, white sand laminae. (CL-ML)	/ / / / /	HNu readings on soil = 0-80ppm
25					BORING TERMINATED @ 24'		Installed monitor well screen interval 7.0'-22.0' pH = 5.13 Cand. = 105 umhos

NOTE: SOIL DESCRIPTIONS ON THIS LOG ARE A SUMMARY OF FIELD LOGS, VISUAL CLASSIFICATIONS, OR LABORATORY TESTS, IF ANY D1586ACAD

SOIL BORING LOG

PROJECT COLUMBUS AFB RI LOCATION SS-5, AREA 3
 ELEVATION 202.27 (ft. msl) DRILLING CONTRACTOR BURMAH TECHNICAL SERVICES
 DRILLING METHOD AND EQUIPMENT HOLLOW STEM AUGER / MOBILE B-56
 WATER LEVEL AND DATE 190.57' (msl) 4/12/88 START 3/13/88 FINISH 3/13/88 LOGGER D. HOLLOWAY

DEPTH BELOW SURFACE (FT)	SAMPLE			STANDARD PENETRATION TEST RESULTS	SOIL DESCRIPTION	SYMBOLIC LOG	COMMENTS
	INTERVAL	TYPE AND NUMBER	RECOVERY (IN)	6"-6" 6'-6"	SOIL NAME, COLOR, MOISTURE CONTENT, RELATIVE DENSITY OR CONSISTENCY, SOIL STRUCTURE, MINERALOGY, USCS GROUP SYMBOL		DEPTH OF CASING, DRILLING RATE, DRILLING FLUID LOSS, TESTS AND INSTRUMENTATION
0		S-1	23"	1-3 1-3	<u>SILTY SAND</u> ; dark brown to tan, dry, soft, very fine. (SM)		Start 830 Using 300lb. hammer and 3" split spoon
		S-2	23"	2-3 3-5	--- <u>SAND WITH CLAY</u> ; gray to orange, dry, non-plastic. (SC)	/ / / / /	LEL-02 = 0-21% HNU reading in borehole and breathing zone = Oppm
5		S-3	23"	2-5 6-9	---	/ / / / /	
		S-4	24"	2-7 8-10	--- <u>SANDY CLAY</u> ; dark gray to orange, dry, stiff, slight plasticity. (CL)	/ / / / /	
		S-5	22"	4-9 11-31	<u>SAND</u> ; gray, moist, dense, fine, occasional gravel. (SP)	
10		S-6	21"	1-3 22-32	---; wet with gravel 11'-12' >15%. (SP)	LEL-02 = 0-21% HNU reading in borehole and breathing zone = Oppm
		S-7	20"	10-23 32-47	<u>SAND AND GRAVEL</u> ; gray with varied. color gravel, wet, well graded. (GW)	o o o o o	CSL Soil Sample 930
15		S-8	19"	6-17 20-21	---	o o o o o	
		S-9	19"	4-8 11-9	<u>SAND AND GRAVEL</u> ; with silt, orange to tan, varied gravel up to 1" in diameter. (GM)	o o o o o	
		S-10	18"	5-14 14-11	---; tan, less silt. (GM)	o o o o o	
20		S-11	18"	5-5 6-14	---	o o o o o	
		S-12	20"	4-10 14-19	---; silt >20%. (GM)	o o o o o	
25		S-13	20"	3-7 10-15	<u>SILTY CLAY</u> ; dark gray, dry, stiff, occasional fine sand laminae, slightly plastic. (CL)	/ / / / /	HNU readings on soil = 0-0.4ppm
					BORING TERMINATED @ 26'		Installed monitor well screened interval 8'-23' pH = 5.08 Cond. = 82 umhos

NOTE: SOIL DESCRIPTIONS ON THIS LOG ARE A SUMMARY OF FIELD LOGS, VISUAL CLASSIFICATIONS, OR LABORATORY TESTS, IF ANY D1586ACAD

PROJECT COLUMBUS AFB, RT LOCATION SS-5, AREA 3
 ELEVATION 207.90 (ft. msl) DRILLING CONTRACTOR BURMAH TECHNICAL SERVICES
 DRILLING METHOD AND EQUIPMENT HOLLOW STEM AUGER / MOBILE B-56
 WATER LEVEL AND DATE 188.35' (msl) 4/13/88 START 3/13/88 FINISH 3/13/88 LOGGER D. HOLLOWAY

DEPTH BELOW SURFACE (FT)	SAMPLE			STANDARD PENETRATION TEST RESULTS	SOIL DESCRIPTION	SYMBOLIC LOG	COMMENTS
	INTERVAL	TYPE AND NUMBER	RECOVERY (IN)	6"-6" 6'-6"	SOIL NAME, COLOR, MOISTURE CONTENT, RELATIVE DENSITY OR CONSISTENCY, SOIL STRUCTURE, MINERALOGY, USCS GROUP SYMBOL		DEPTH OF CASING, DRILLING RATE, DRILLING FLUID LOSS, TESTS AND INSTRUMENTATION
0		S-1	22"	2-2 2-4	SANDY SILT; brown, dry, soft root material. (ML) SANDY CLAY; gray to orange, dry, stiff, slight plasticity. (CL)		Start 3/13/88 1430 Using 300lb. hammer and 3" split spoon.
		S-2	21"	3-2 12-14	--- SILTY SAND; gray to orange, dry, dense, fine. (SM)		
5		S-3	20"	5-6 5-5	---		
		S-4	21"	3-2 2-2	---; moist. (SM) SILTY SAND; tan, wet, dense, fine. (SM)		LEL-0 ₂ = 0-20% HNu reading in borehole and breathing zone = 0ppm
		S-5	22"	3-2 4-7	---; clay 9.5'-10', gray to orange. (SM-CL)		
10		S-6	23"	2-6 8-9	SILTY SAND; tan, moist, very fine changing color @ 11' to gray and orange. (SM)		CSL soil sample 1500 HNu reading in borehole and breathing zone = 0ppm
		S-7	24"	2-3 5-6	SANDY CLAY; gray to orange, moist, very stiff from 11'-12', slight plasticity. (CL)		
15		S-8	24"	3-9 16-44	SILTY SAND; tan, moist, very fine, soft sandy clay, very stiff. (SM-CL) SAND; gray, dense, fine to medium, fine gravel > 10%. (SP)		CSL soil sample 1530
		S-9	18"	16-49 57	---; wet gravel increasing, strong odor. (SP)		Refusal 17.5' LEL-0 ₂ = 0-21% HNu reading in borehole = 70ppm in breathing zone = 0ppm
20		S-10	20"	7-30 44-48	---; wet. (SP)		
		S-11	23"	9-18 17-18	SAND AND GRAVEL WITH SILT; gray with varied color gravel pebbles to cobbles, sand > 20%. (GM)		
		S-12	22"	9-14 16-19	---; odor. (GM)		LEL-0 ₂ = 0-21% HNu reading in borehole = 50ppm in breathing zone = 1ppm
25		S-13	23"	6-7 12-16	---; slight odor. (GM)		
		S-14	23"	4-6 7-14	---; odor. (GM)		
30		S-15	23"	17-8 12-19	---; odor. (GM) SAND; orange to tan, dense, fine to medium, small clay lenses. (SP)		

NOTE: SOIL DESCRIPTIONS ON THIS LOG ARE A SUMMARY OF FIELD LOGS, VISUAL CLASSIFICATIONS, OR LABORATORY TESTS, IF ANY D1586ACAD

PROJECT NUMBER
MG22751.40

BORING NUMBER
W-17, W-46 SHEET 2 OF 2

SOIL BORING LOG

PROJECT COLUMBUS AFB, RI

LOCATION SS-5, AREA 3

ELEVATION 207.90 (ft. msl)

DRILLING CONTRACTOR BURMAH TECHNICAL SERVICES

DRILLING METHOD AND EQUIPMENT HOLLOW STEM AUGER / MOBILE B-56

WATER LEVEL AND DATE 188.35' (msl) 4/13/88

START 3/13/88

FINISH 3/13/88













LOGGER D. HOLLOWAY

DEPTH BELOW SURFACE (FT)	SAMPLE			STANDARD PENETRATION TEST RESULTS 6"-6" 6"-6"	SOIL DESCRIPTION SOIL NAME, COLOR, MOISTURE CONTENT, RELATIVE DENSITY OR CONSISTENCY, SOIL STRUCTURE, MINERALOGY, USCS GROUP SYMBOL	SYMBOLIC LOG	COMMENTS DEPTH OF CASING, DRILLING RATE, DRILLING FLUID LOSS, TESTS AND INSTRUMENTATION
	INTERVAL	TYPE AND NUMBER	RECOVERY (IN)				
30		S-16	23	9-14 14-12	--- CLAY; orange-brown changing to dark gray, stiff. (CL)		
35					BORING TERMINATED. @ 32'		HNu readings on soil headspace: 15' = 25ppm 17' = 180ppm 19' = 160ppm 21' = 120ppm 23' = 120ppm 25' = 60ppm 27' = 125ppm 29' = 70ppm Install monitor well Screened interval 13.5'-28.5' Floating fuel layer ~ 1' thick 4/12/88 installed 4" monitor well, W-46 screened interval 13'-28'

NOTE: SOIL DESCRIPTIONS ON THIS LOG ARE A SUMMARY OF FIELD LOGS, VISUAL CLASSIFICATIONS, OR LABORATORY TESTS, IF ANY

D1586ACAD

PROJECT COLUMBUS AFB, RI LOCATION SS-5, AREA 3
 ELEVATION 198.98 (ft. msl) DRILLING CONTRACTOR BURMAH TECHNICAL SERVICES
 DRILLING METHOD AND EQUIPMENT HOLLOW STEM AUGERS / MOBILE B-56 / ARDCO ATV
 WATER LEVEL AND DATE 189.11' (msl) 4/12/88 START 3/30/88 FINISH 3/30/88 LOGGER J. HOLLOWAY

DEPTH BELOW SURFACE (FT)	SAMPLE			STANDARD PENETRATION TEST RESULTS	SOIL DESCRIPTION	SYMBOLIC LOG	COMMENTS
	INTERVAL	TYPE AND NUMBER	RECOVERY (IN)	6'-6"	SOIL NAME, COLOR, MOISTURE CONTENT, RELATIVE DENSITY OR CONSISTENCY, SOIL STRUCTURE, MINERALOGY, USCS GROUP SYMBOL		DEPTH OF CASING, DRILLING RATE, DRILLING FLUID LOSS, TESTS AND INSTRUMENTATION
				6'-6"			
0		S-1	20"	10-10 7-10	<u>TOPSOIL</u> <u>SILTY SAND</u> ; brown to rust, moist, fine to medium, moderate density, occasional quartz cobble. (SM)		Using 300lb. hammer and 3" split spoon.
		S-2	24"	6-8 12-17	<u>SILTY CLAYEY SAND</u> ; gray, moist, very fine to fine, medium density, mottled, fines >30% (SC-SM)		
5		S-3	24"	4-6 10-15	<u>SILTY SAND</u> ; light gray, moist, very fine to medium, medium density, silt <25% (SM)		
		S-4	24"	4-8 17-40	-- --; less fines. (SM) <u>SILTY SAND AND GRAVEL</u> ; brown to gray, moist, fine to coarse sand, loose, fine to medium quartz gravel, silt <15% (SM-GM)		
		S-5	24"	10-16 32-34	-- --; wet. (SM-GM) <u>WELL GRADED GRAVEL WITH SAND</u> ; light gray, fine to coarse gravel, very loose, very fine to coarse sand, silt <5% (GW)		
10		S-6	24"	12-19 19-21	-- --; tan to light gray. (GW)		CSL soil sample
		S-7	24"	7-14 16-18	-- --; brown, fines <10% (GW)		
15		S-8	24"	7-6 9-8	-- --		
		S-9	24"	15-14 15-16	-- --		CSL soil sample
		S-10	24"	11-9 17-25	-- -- <u>SILTY SAND</u> ; dark gray to white, wet, very fine to fine, loose. (SM)		
20		S-11	24"	16-23 27-34	-- --		
		S-12	24"	- -	<u>SILTY CLAY WITH SAND</u> ; dark gray, dry, hard (CL)		HNU headspace readings on soil = 0 ppm
25					BORING TERMINATED @ 24.0'		Installed monitor well screened interval 5'-20' pH = 5.64 Cond. = 130 umhos

NOTE: SOIL DESCRIPTIONS ON THIS LOG ARE A SUMMARY OF FIELD LOGS, VISUAL CLASSIFICATIONS, OR LABORATORY TESTS, IF ANY DIS86ACAD